

sensi
by **COPELAND**

SA20 Equipment Interface Module

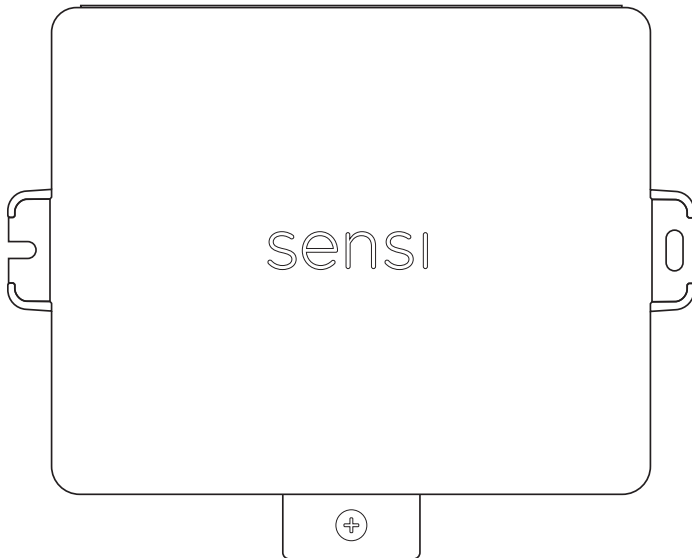

Installation guide

Equipment Interface Module is compatible with:

- Sensi Touch 2 smart thermostat
- Up to 4H/2C multi-stage and heat pump systems.
- 3 universal terminals supporting humidification, dehumidification, and ventilation.

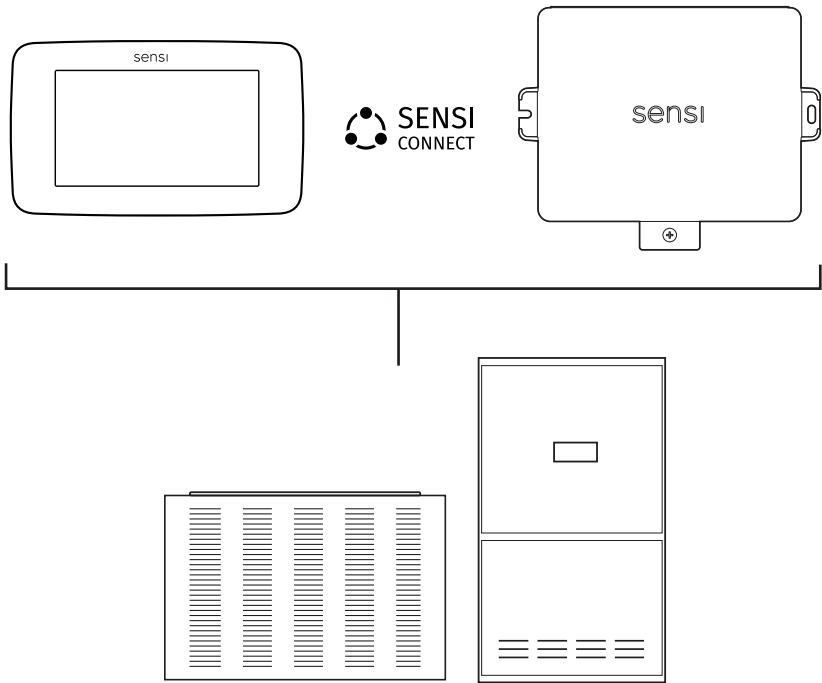

Indoor/Outdoor Applications

Waterproof and durable, the Sensi EIM is made for indoor or outdoor use, again lessening the number of products you need to stock on your truck. The cover is tightly secured on the product, keeping a clean look without wires popping out.

1 Install thermostat

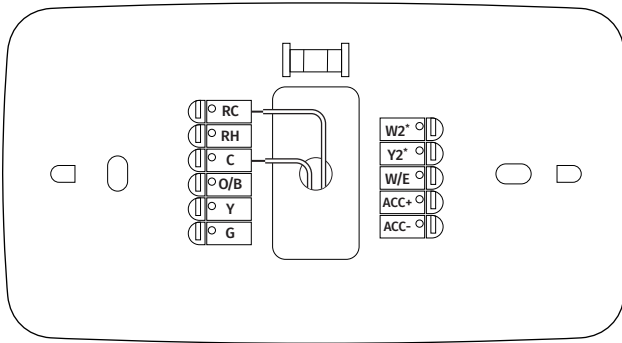

Turn off power to the HVAC system before installing. Mount the thermostat and install a wire to the C terminal and another wire to either RC or RH terminal of the Sensi Touch 2 smart thermostat or to separate 24 volt transformer (not provided).

2 Install equipment interface module

Use screws and anchors as appropriate for the mounting surface. Mount the EIM near the HVAC equipment, or on the equipment itself.

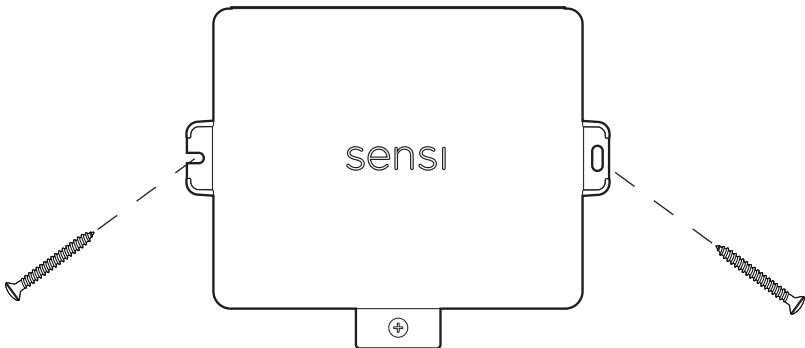

3 Wire the equipment interface module

Remove cover and install the following:

- Wires coming from the Thermostat to the R and C terminals (under T-STAT).
- Power wires coming from the HVAC system to the C and RC or RH terminals (under 24V)*.
- Wires for the HVAC system and Accessories based on the diagrams on the following pages.

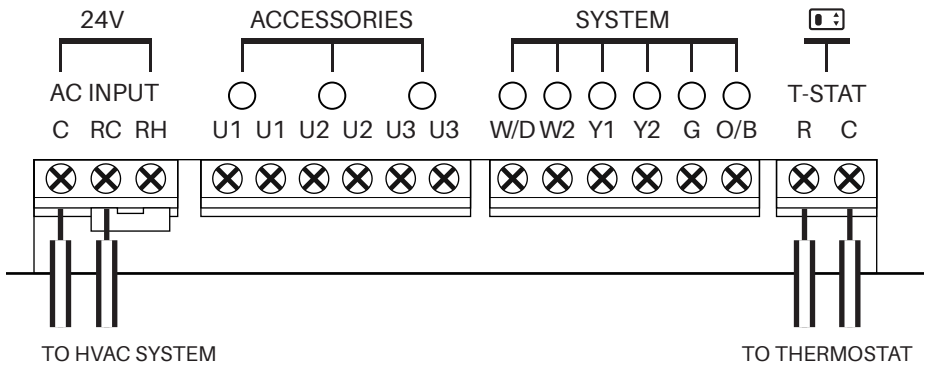

*Remove jumper if using separate transformers.

EIM wiring guide – conventional systems

Typical wiring of a conventional system with up to 3-stage heat and 2-stage cool with two transformers.

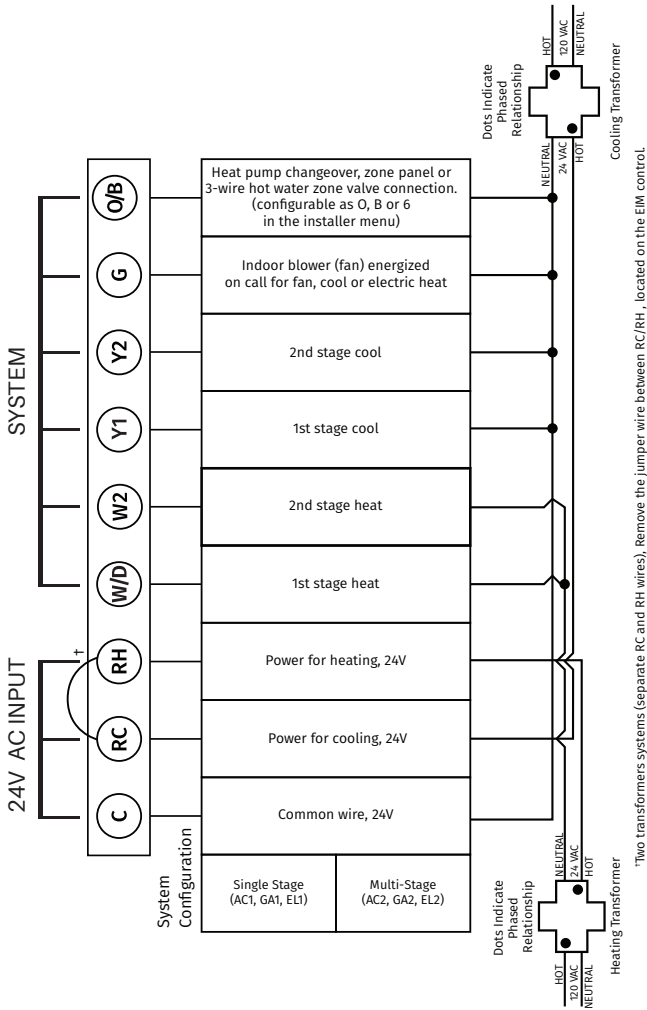

1 Remove jumpers if using separate transformers.

EIM wiring guide – heat pump systems

Typical wiring of a heat pump system with up to 4-stage heat and 2-stage cool with one transformer.

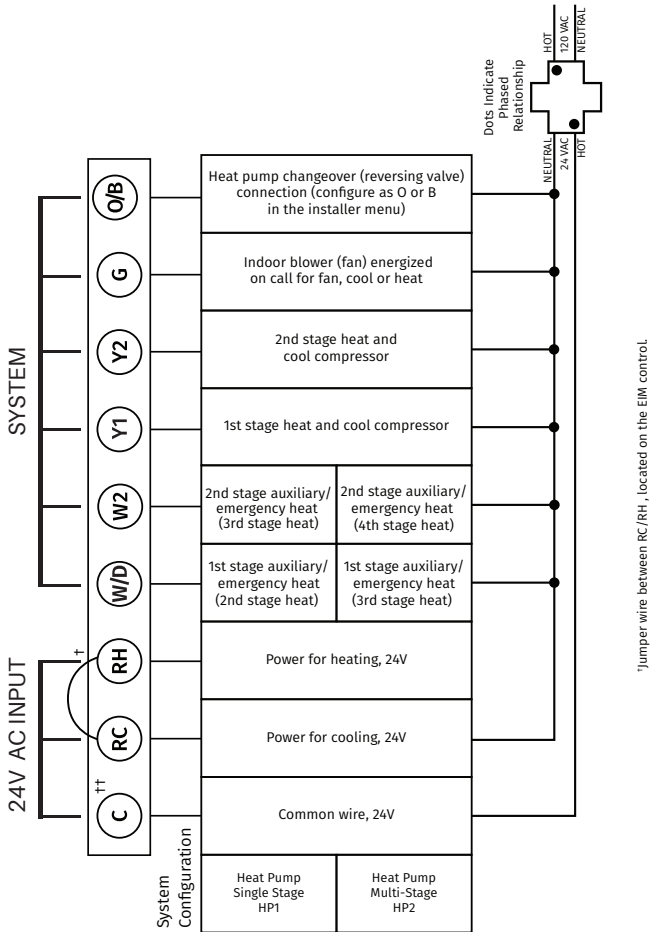

- 1 Remove jumpers if using separate transformers.
- 2 The changeover valve will be labeled O if energized in cool or B if energized in heat.
- 3 The auxiliary heat stage(s) are labeled differently on different heat pump air handlers. Most heat pumps applications only have one stage of auxiliary heat.

EIM wiring guide – wiring humidification, dehumidification and ventilation

U terminals can be used for humidification, dehumidification or ventilation.

TYPICAL HOOKUP OF POWERED HUMIDIFIER

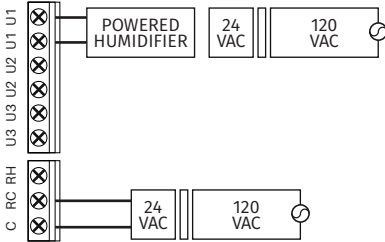

TYPICAL HOOKUP OF NON-POWERED HUMIDIFIER

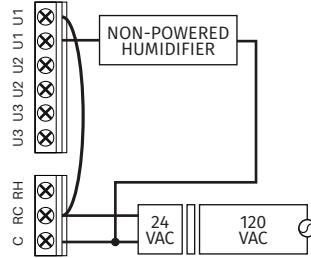

TYPICAL HOOKUP OF POWERED VENTILATION

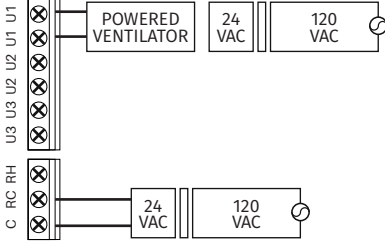

TYPICAL HOOKUP OF NON-POWERED VENTILATION

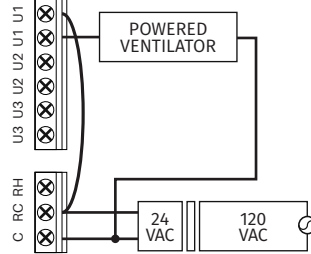

TYPICAL HOOKUP OF POWERED DEHUMIDIFIER (WHOLE HOUSE DEHUMIDIFIER)

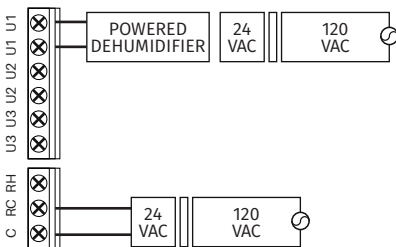

TYPICAL HOOKUP OF VARIABLE SPEED BLOWER FOR DEHUMIDIFICATION IN LOW SPEED

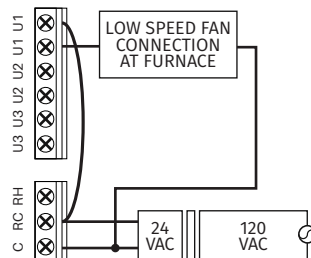

Any combination of relays (U1, U2, U3) can be used. They are set in the thermostat installer setup.



Wire the U relay to the low speed fan for dehumidification control at the equipment. The EIM relay can be set to be normally-open or normally-closed in the thermostat installer setup.



Normally-open, dry contacts



Normally-closed, dry contacts

4 Connecting the EIM to the Sensi Touch 2 smart thermostat

Power back on the HVAC system.

When the Touch 2 is powered up, navigate to the menu in the top left corner (four squares) on the screen and select Advanced Setup. Next select EIM.

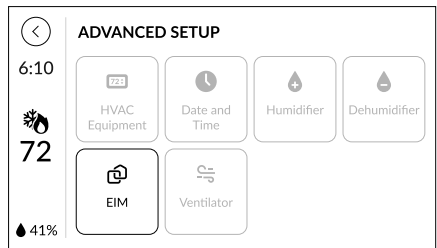
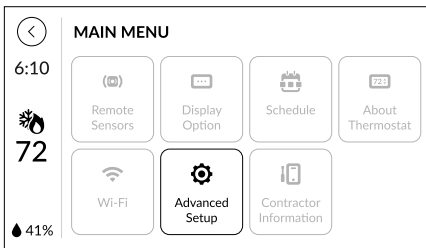

Press the “Add” button and then select if the EIM is being used as an indoor or outdoor module.

- Indoor is when the EIM is attached to the furnace, air handler, or IAQ equipment.
- Outdoor is when the EIM is attached outside to control the air conditioner or heat pump.

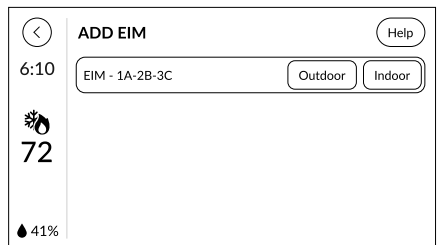
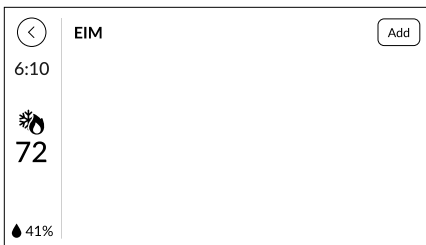

Note: The EIM number being displayed on the thermostat should match the number printed on the EIM

5 Configure additional accessories (humidifier, dehumidifier, ventilation)

Go to main menu and select “Advanced Setup”. Next select “HVAC Equipment” then “Configure”. Finally, select “Additional Accessories”.

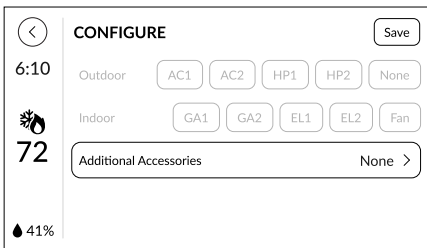
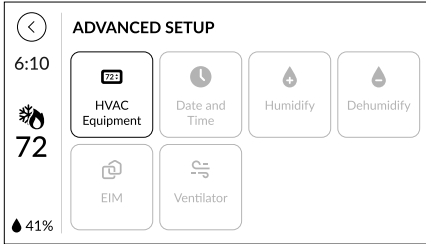

For each accessory wired into the EIM, select the corresponding terminal.

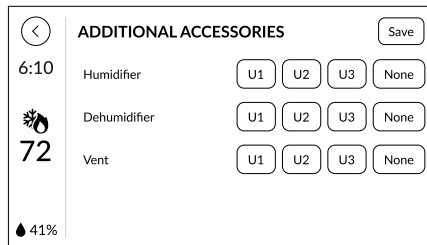

System Testing

Once the thermostat is installed and properly configured, you can test the equipment using the following steps.

COOLING SYSTEM

- Press the **Mode** button on the thermostat and select the **Cool** position.
- Press \ominus and adjust the setting to 1° below the current room temperature. The blower should come on immediately on high speed, followed by cold air circulation. The temperature display will turn blue.
Note: that there can be up to a 5 minute delay for this process. This is indicated by a flashing setpoint temperature.
- Press \oplus and adjust the setting to 1° above the current room temperature. The cooling system should stop operating and the temperature display will go to a white color.
- Go to the EIM and check that the LED light for the corresponding system terminal is on.

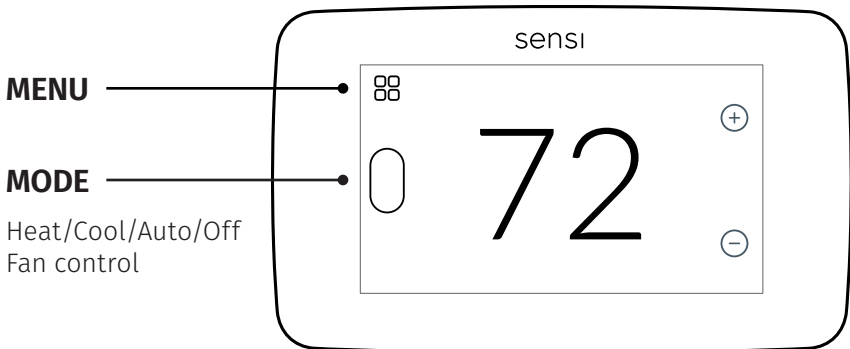

HEATING SYSTEM

- Press the **Mode** button on the thermostat and select the **Heat** position.
- Press **+** on the thermostat and adjust the setting to 1° above the current room temperature. The heating system should begin to operate and the thermostat temperature display will turn orange indicating heating on the screen.
- For heat pumps with auxiliary, press **+** on the thermostat and adjust the setting to 3° above the current room temperature. The auxiliary heat should begin to operate and the thermostat will indicate “Heating Auxiliary” on the screen.
- Press **-** on the thermostat and adjust the setting to 1° below the current room temperature. The heating system should stop operating and the temperature will go back to a white color.
- Go to the EIM and check that the LED light for the corresponding system terminal is on.

AUXILIARY SYSTEM

(only for heat pumps with auxiliary)

- Press the **Mode** button on the thermostat and select the **Aux** position. This bypasses the heat pump and runs auxiliary-only heat.
- Press **+** on the thermostat and adjust the setting to 1° above the current room temperature. The auxiliary heating system should begin to operate.
- Press **-** on the thermostat and adjust the setting to 1° below the current room temperature. The auxiliary heating system should stop operating and “Heating Auxiliary” will disappear from the screen.
- Go to the EIM and check that the LED light for the corresponding system terminal is on.

FAN OPERATION

- If your system does not have a “G” terminal connection, skip to “Heating System” below.
- Press the **Fan** button on the thermostat and select the **On** position. The blower should begin to operate.
- Press **Mode** (oval button on left side) to turn off the system. Then press the **Fan** button on the thermostat and select the **Auto** position. The blower should stop immediately.
- Go to the EIM and check that the LED light for the corresponding system terminal is on.

CIRCULATING FAN

- Press the **Mode** button on the thermostat then set Circulating fan to **On**
- Set the % run time from 10%-100% in 5% increments (default is OFF).
- The % run time is the percentage of time the fan shall run in a day. This calculation takes into account the amount of time the heating, cooling and continuous fan have run during the same day.
- Go to the EIM and check that the LED light for the corresponding system terminal is on.

HUMIDIFICATION

- Press **Menu > Advanced Setup > Humidify**
- Set Humidification to **On** and set the humidity set point higher than the current room humidity.
- Humidity can be adjusted from 5% to 50% in 5% increments.
- Go to the EIM and check that the LED light for the corresponding system terminal is on.
- Go to the EIM and check that the LED light for the corresponding system terminal is on.

DEHUMIDIFICATION

- Press **Menu > Advanced Setup > Dehumidify**
- Set Dehumidification to **On** and set the humidity set point lower than the current room humidity. Humidity can be adjusted from 40% to 95% in 5% increments.
- Depending on installed equipment, check that the system fan speed has slowed, the dehumidifier is running, or the system cools up to 3° below temperature set point or until the humidity set point is reached.
- Go to the EIM and check that the LED light for the corresponding system terminal is on.

VENTILATION

- Press **Menu > Advanced Setup > Ventilator**
- Set ventilator to Minimum and set runtime to 60 min/hour.
- Go to the EIM and check that the LED light for the corresponding system terminal is on.

Troubleshooting

| SYMPTOM | POSSIBLE CAUSE | CORRECTIVE ACTION |
|--|---|---|
| EIM Status LED light solid red | EIM is not connected | Press and hold the RESET button to restart the pairing process. Once the pairing process has started, the LED light will be flashing green. Once pairing process is complete, the LED light will be solid green. |
| EIM not connecting to Sensi Touch 2 smart thermostat | <ol style="list-style-type: none"> 1. EIM may be located too far from the thermostat 2. EIM signal is experiencing interference | Move the EIM closer and/or to a location that it gets better signal strength. |
| No Heat/ No Cool/ No Fan (common problem) | <ol style="list-style-type: none"> 1. Blown fuse or tripped circuit breaker 2. Furnace power switch to OFF 3. Furnace blower compartment door panel loose 4. Loose connection to thermostat or system | <ol style="list-style-type: none"> 1. Replace fuse or reset breaker 2. Turn switch to ON 3. Replace door panel in proper position to engage safety interlock or door switch 4. Tighten connections |
| No Heat | <ol style="list-style-type: none"> 1. Thermostat not set to Heat 2. Loose connection to thermostat or system 3. Heating system requires service or thermostat requires replacement | <ol style="list-style-type: none"> 1. Set thermostat to Heat. 2. Verify thermostat and system wires are securely attached. 3. Diagnostic: Set Mode to Heat and raise the setpoint above room temperature. Within five minutes the thermostat should make a soft click sound and the temperature display should turn orange. This sound indicates the thermostat is operating properly. If the thermostat does not click, try resetting the thermostat. If the thermostat does not click after being reset, contact your heating and cooling service person or place of purchase for a replacement. If the thermostat clicks, verify the heating system is operating correctly. |
| No Cool | <ol style="list-style-type: none"> 1. Thermostat not set to Cool 2. Loose connection to thermostat or system 3. Cooling system requires service or thermostat requires replacement | <ol style="list-style-type: none"> 1. Set thermostat to Cool. 2. Verify thermostat and system wires are securely attached. 3. Diagnostic: Set Mode to Cool and lower setpoint below room temperature. Same procedures as diagnostic for "No Heat" condition except set the thermostat to Cool and lower the setpoint below the room temperature. There may be up to a five minute delay before the thermostat clicks in Cooling if the AC Protection feature is on. |

| SYMPTOM | POSSIBLE CAUSE | CORRECTIVE ACTION |
|---|--|---|
| Heat, Cool or Fan Runs Constantly | Possible short in wiring, thermostat, heat, cool or fan system | Check each wire connection to verify they are not shorted or touching other wires. Try resetting the thermostat. |
| Thermostat Display & Thermometer Disagree | Thermostat display requires adjustment | Display can be adjusted +/-5° using the Temperature Offset in Sensi app. |
| Humidity Display & Hygrometer Disagree | Humidity display requires adjustment | Display can be adjusted in 5% increments +/-25% using the Humidity Offset in the Sensi app. |
| Display is Blank | The display could be turned off or you need a common wire (c- wire) | Attach a common wire (c-wire) or turn on the display. |
| Furnace (Air Conditioner) Cycles Too Fast or Slow | The location of the thermostat and/or the size of the Heating System may be influencing the cycle rate | Digital thermostats provide precise control and cycle faster than older mechanical models. The system turns on and off more frequently, but runs for a shorter time. If you would like to increase cycle time, choose Slow for the Cycle Rate in the Sensi app. |
| "Call for Service" appears on the screen | <ol style="list-style-type: none"> 1. Heating or Cooling system is not able to heat/cool the space to within 5 degrees of the setpoint within 2 hours 2. If "--" is displayed for the Room Temperature, a replacement thermostat is needed 3. None of the buttons operate on the thermostat | <ol style="list-style-type: none"> 1. See corrective action for "No Heat" or "No Cool" 2. Replace thermostat 3. Make sure keypad lockout is not turned on. If it's OFF, try resetting the thermostat. <p>Reset: Turn the power to your system off, wait 5 seconds and turn it back on.</p> |

Specifications

Control for up to 4 Heat/2 Cool heat pump systems or up to 3 Heat/2 Cool conventional systems. 3 optional accessory terminals for humidification, dehumidification and ventilation.

Operating Ambient Temperature

Equipment Interface Module: -40 to 165° F (-40 to 74° C)

Operating Relative Humidity

Equipment Interface Module: 5% to 95% (non-condensing)

Physical Dimensions

Equipment Interface Module:

8.5" W x 6.75" H x 1.5" D

(216 W x 171 H x 38 D mm)

Electrical ratings

| TERMINAL | VOLTAGE (50/60 HZ) | MAX. CURRENT RATING |
|--------------------------------------|--------------------|---------------------|
| W1 (stage 1 heat) | 18 to 30 VAC | 1.00A |
| W2/Aux1 (stage 2 heat or aux heat 1) | 18 to 30 VAC | 0.60A |
| G (fan) | 18 to 30 VAC | 0.50A |
| Y1 (compressor stage 1) | 18 to 30 VAC | 1.00A |
| Y2 (compressor stage 2) | 18 to 30 VAC | 0.60A |
| O/B (changeover valve) | 18 to 30 VAC | 1.00A |
| U1, U2, or U3 (dry contacts) | 18 to 30 VAC | 0.50A |
| L (input for heat pump) | | |



CAUTION: ELECTRONIC WASTE NOTICE

The product should not be disposed of with other household waste. Check for the nearest authorized collection centers or authorized recyclers. The correct disposal of end-of-life equipment will help prevent potential negative consequences for the environment and human health.



DISCONNECT POWER BEFORE INSTALLATION.

Can cause electrical shock or equipment damage.



MUST BE INSTALLED BY A TRAINED, EXPERIENCED TECHNICIAN.

Can cause electrical shock or equipment damage.

Regulatory information

FCC Regulations

This device complies with part 15 of the FCC Rules. Operation is subject to the following two conditions: (1) This device may not cause harmful interference, and (2) this device must accept any interference received, including interference that may cause undesired operation.

Changes or modifications not expressly approved by the manufacturer could void the user's authority to operate the equipment.

The antenna(s) used for this transmitter must not be co-located or operating in conjunction with any other antenna or transmitter.

This equipment has been tested and found to comply with the limits for a Class B digital device, pursuant to part 15 of the FCC Rules.

These limits are designed to provide reasonable protection against harmful interference in a residential installation. This equipment generates, uses and can radiate radio frequency energy and, if not installed and used in accordance with the instructions, may cause harmful interference to radio communications. However, there is no guarantee that interference will not occur in a particular installation. If this equipment does cause harmful interference to radio or television reception, which can be determined by turning the equipment off and on, the user is encouraged to try to correct the interference by one or more of the following measures:

- Reorient or relocate the receiving antenna.
- Increase the separation between the equipment and receiver.
- Connect the equipment into an outlet on a circuit different from that to which the receiver is connected.
- Consult the dealer or an experienced radio/TV technician for help.

RF Exposure

This device complies with FCC RF radiation exposure limits set forth for an uncontrolled environment.

The antenna(s) used for this transmitter must not be co-located or operating in conjunction with any other antenna or transmitter and must be installed to provide a separation distance of at least 20cm from all persons.

The FCC grant can be found under the Display Grant section of <http://www.fcc.gov/oet/fccid> after searching on FCC ID: 2A4JN-SA20

IC Notice

This device complies with Industry Canada license-exempt RSS standard(s). Operation is subject to the following two conditions: (1) this device may not cause interference, and (2) this device must accept any interference, including interference that may cause undesired operation of the device.

This Class B digital apparatus complies with Canadian ICES-003.

IC ID: 28229-SA20

sensi
by **COPELAND**

