

# ENGINEERING DATA



## HEALTHY HOME SYSTEM DEHUMIDIFIER

Models: FC-60DH2, FC-85DH2, FC-120DH2



### MODEL PART NUMBER

- FC-60DH-2 602617201
- FC-85DH-2 602617202
- FC-120DH-2 602617203

### OPTIONAL ACCESSORIES AND REPLACEMENT PARTS

PART NO.	MODEL	DESCRIPTION
602609204	SM10C	Inlet/Outlet Collars (60DH/85DH)
602609205	LG10C	Inlet/Outlet Collars (120DH)
602609206	DH1-RCK	Remote Control Kit with CAT-5 Cable 25ft
602609207	DH2-HK	Hanging Kit Assembly (Fits 60DH/85DH/120DH)
602609701	SM10PF	Prefilter Replc 60DH/85DH
602609702	LG10PF	Prefilter Replc 120DH
602609703	SMM10	MERV10 Replc Filter 60DH/85DH
602609704	LGM10	MERV10 Replc Filter 120DH

### DESCRIPTION

Field Controls Dehumidifiers (FC-DH2) feature an upgrade to the original DH model with auto internal/external control detection. The DH-2 can be controlled with an external humidistat or by the integrated humidistat to monitor the conditioned space. The DH-2 whole-home dehumidifier ensures the home is maintained at proper humidity levels professionally.

MODEL	DESCRIPTION	COVERAGE	WEIGHT
FC-60DH2	60 Pint Whole House Dehumidifier	11,000FT <sup>3</sup>	56lbs
FC-85DH2	85 Pint Whole House Dehumidifier	15,000FT <sup>3</sup>	56lbs
FC-120DH2	120 Pint Whole House Dehumidifier	21,000FT <sup>3</sup>	74lbs

### UNIT DIAGRAM

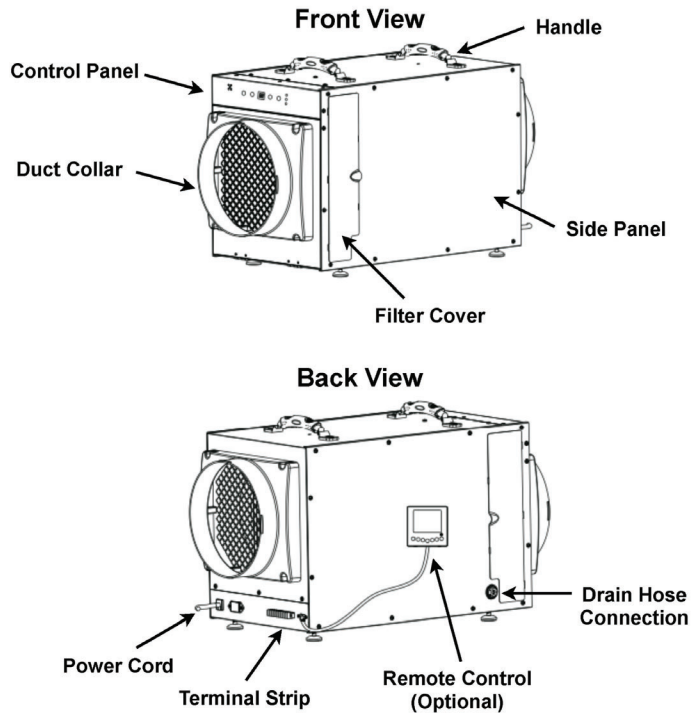

Field Controls  
2630 Airport Road  
Kinston, NC 28504

Customer Service: 252 522-3031  
Fax: 1 (800) 367-7942

Visit us at: [www.fieldcontrols.com](http://www.fieldcontrols.com)

Field Controls LLC reserves the right to modify a product, without prior notice, whether in design, color or specifications, in order to offer at all times a quality product that is highly competitive. Please consult your national and local building codes to find out whether the installation of electrical products requires the services of a certified technician or electrician. Field Controls and Healthy Home System™ are registered Trademarks used under license by Field Controls LLC. All rights reserved.

# ENGINEERING DATA FC-DH

## WHOLE HOUSE DEHUMIDIFIER SPECIFICATIONS

MODEL	FC-120DH-2	FC-85DH-2	FC-60DH-2
Capacity @ 80°F/60%RH:	120 pints per day	85 pints per day	60 pints per day
Capacity @ 73°F/60%RH:	77.15 pints per day	53.0 pints per day	44.5 pints per day
Power Supply	115V/60Hz	115V/60Hz	115V/60Hz
Outlet Requirement	15 Amp, 3 prong, GFCI	15 Amp, 3 prong, GFCI	15 Amp, 3 prong, GFCI
Operating Temp Range	33-105°F	33-105°F	33-105°F
Operating Relative Humidity Range	36%-90%	36%-90%	36%-90%
Airflow @ 0.0" SP	225 CFM	201 CFM	196 CFM
Airflow @ 0.2" SP	190 CFM	162 CFM	156 CFM
Airflow @ 0.4" SP	150 CFM	106 CFM	102 CFM
COP	1.86 L/kWh	1.87 L/kWh	1.88 L/kWh
Refrigerant	R410A	R410A	R410A
Amperage Usage	7.6 Amps	5.3 Amps	4.05 Amps
Sound Level	60 dBA	59 dBA	59 dBA
Dimensions LxWxH	23.75" x 14" x 16"	21.7" x 12" x 12"	21.7" x 12" x 12"

### INDEPENDENT OPERATION MODE

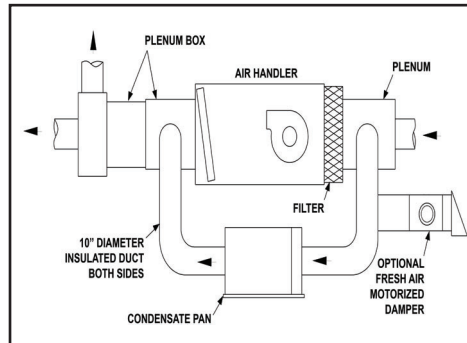
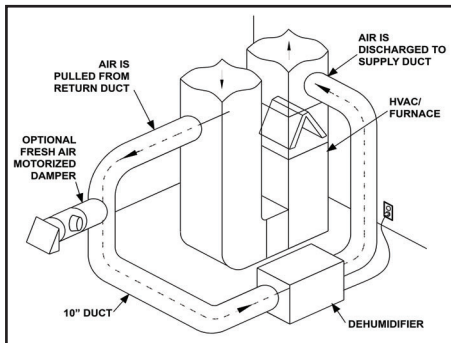

### FREE STANDING APPLICATION CRAWL SPACE/BASEMENT

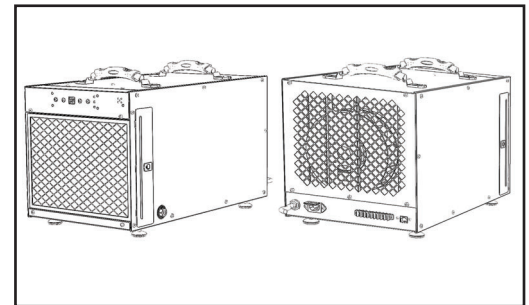

### DEPENDENT OPERATION MODE

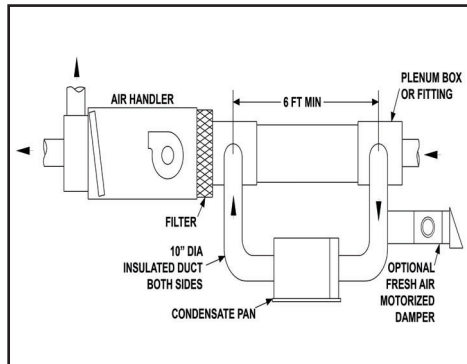
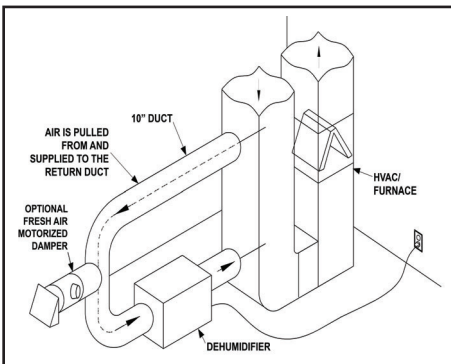

### DROP CEILING MOUNTED INSTALLATION

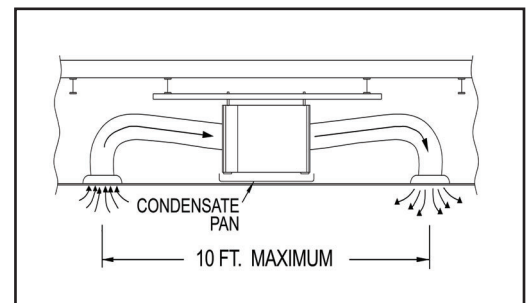

Field Controls  
2630 Airport Road  
Kinston, NC 28504  
Customer Service: 252 522-3031  
Fax: 1 (800) 367-7942

Visit us at: [www.fieldcontrols.com](http://www.fieldcontrols.com)

### PROJECT INFORMATION

Quoted by:	Date:
Project:	Remarks:
Quantity:	
Model:	
Site:	
Architect:	
Engineer:	
Contractor:	