

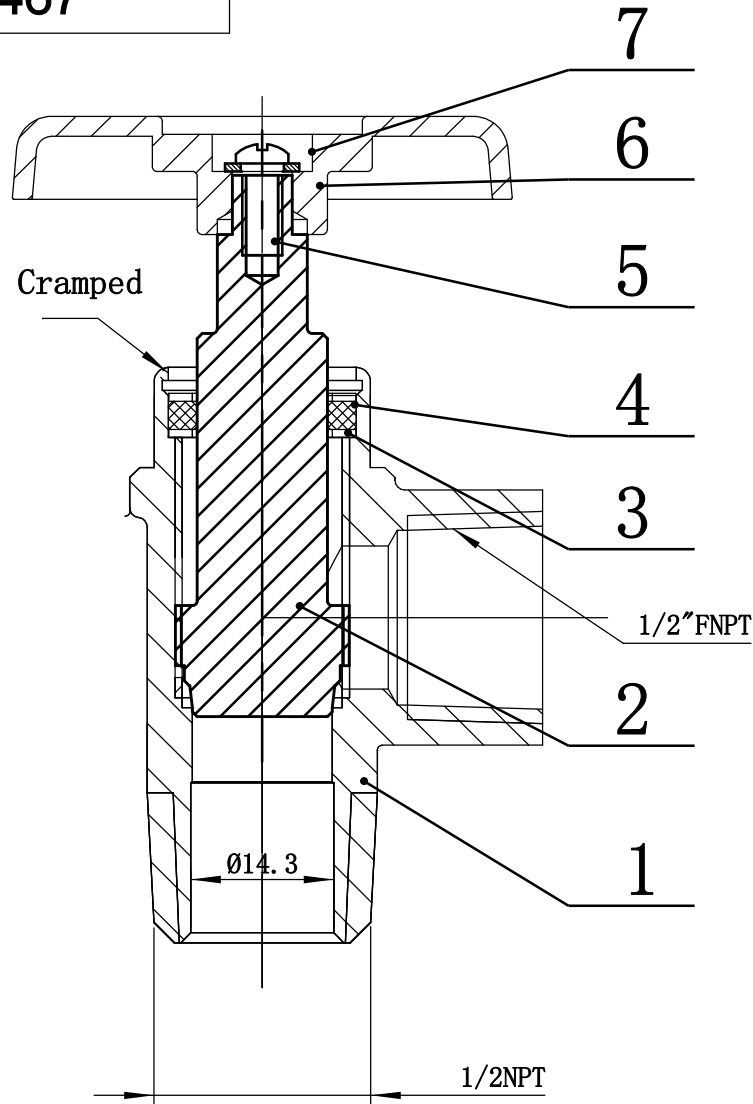

46467



All Dimensions are in mm

NO.	Description	Qty	Material	Remark
7	Washer	1	M4	
6	Wheel Handle	1	Die Casting AL.	E-Coating
5	Round Head Screw	1	C. S.	M4*8 Zinc Plated
4	O-Ring	1	FKM 80	12.3*3.5
3	Gasket	2	C. S. Zinc PL.	14*18.7*0.8
2	Stem	1	Brass	
1	Body	1	Brass	

Midland Industries
 3145 Oak Street
 Kansas City, Missouri 64111

- 1. Black E-Coating Handle
- 2. 200PSI Working pressure
- 3. Working Pressure: -65°F to 250°F

Brass		1/2 X 1/2 FIP X MIP TRUCK VALVE	
Material			
218.8G	1:1	46467 101718-00	
Weight	Scale		