

OTHERS:

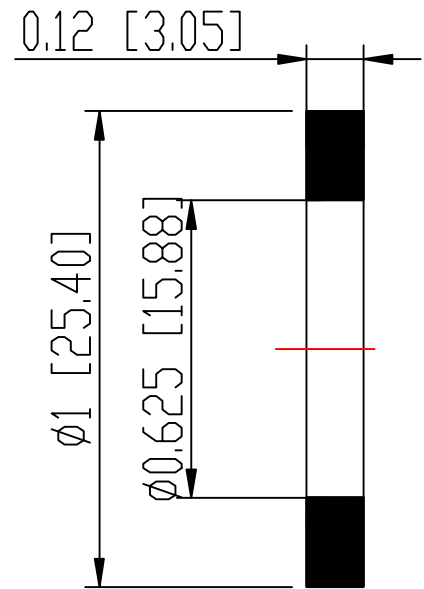
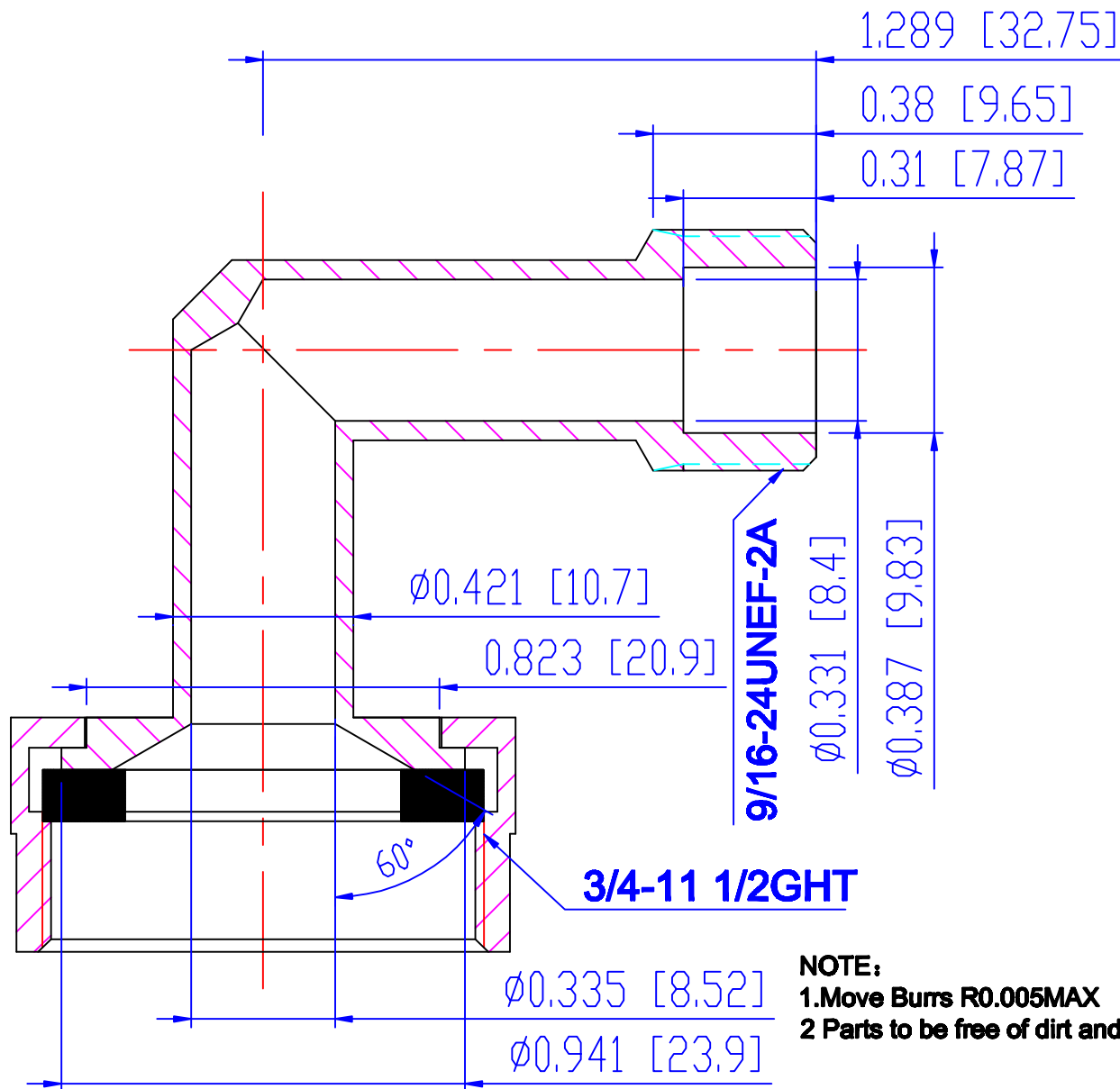
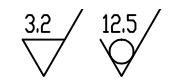

NOTE:
 1. Move Burrs R0.005MAX
 2. Parts to be free of dirt and chips

<p>"This drawing contains proprietary and confidential information of Midland Metal Mfg., Co. and shall not be reproduced, copied, loaned, or submitted to outside parties for examination without our consent"</p>				Date:		UNIT:	INCH	Material:	
				Drawn:		Scale:	1=1	Part Title:	
<p>TOLERANCES ARE: DECIMALS. .X:±0.03 .XX:±0.01 .XXX:±0.005 ANGLES:±1° FRACTIONS ± 1/8</p>				Checked:		PROJECT		PART NO.	30055
				Approved:				MIDLAND METAL MFG. CO. KANSAS CITY, MO	DWG. NO.
NO.	PCA	Date	Revision						