



Install: 1/4 grip and as010 o-ring 1/8-SWIVEL-NUT 008-O-RING

OTHERS:  

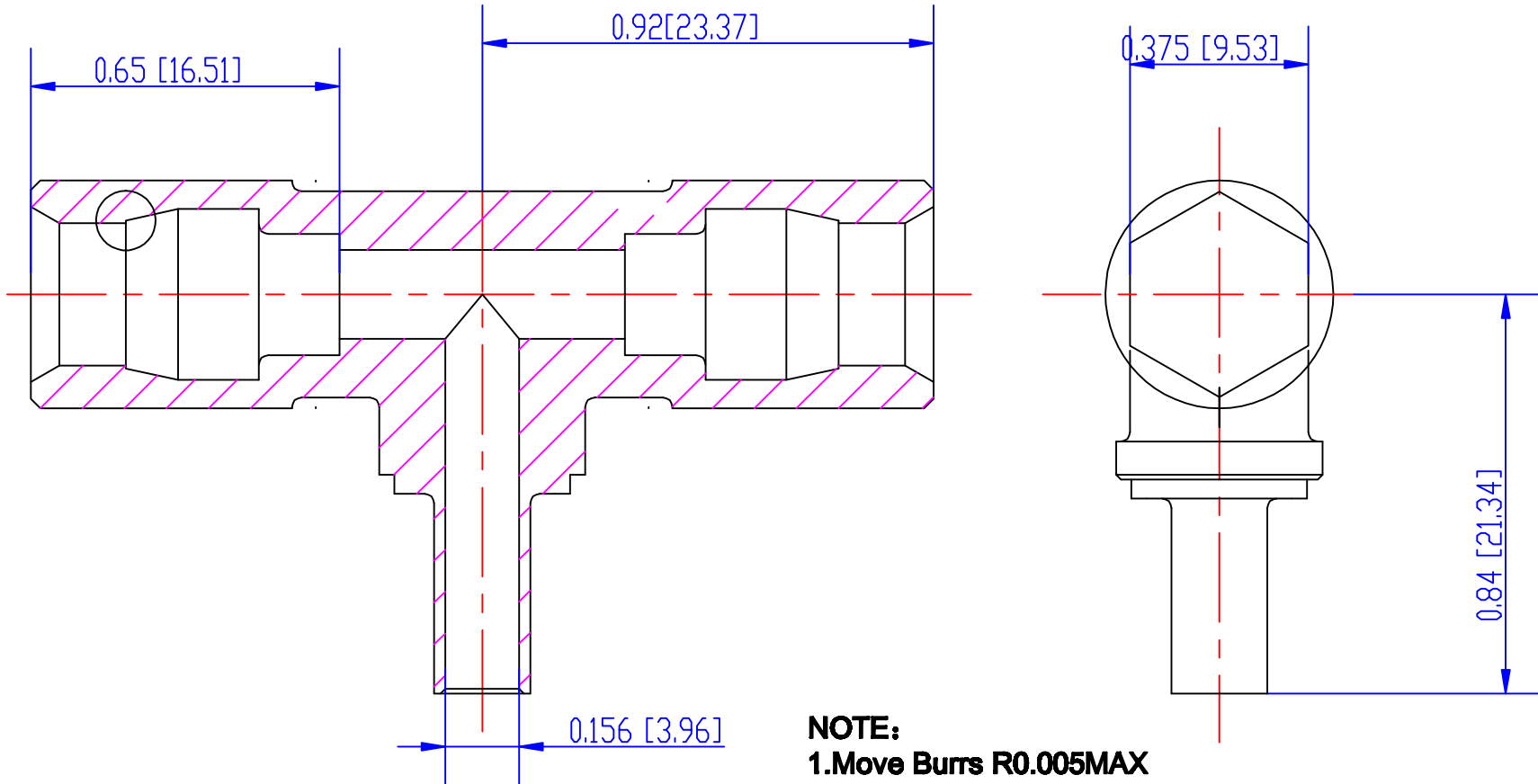
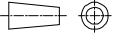

- NOTE:**
1. Move Burrs R0.005MAX
 2. The concentricity with thread within 0.01in
 3. Parts to be free of dirt and chips

<p>"This drawing contains proprietary and confidential information of Midland Metal Mfg., Co. and shall not be reproduced, copied, loaned, or submitted to outside parties for examination without our consent"</p>				Date:		UNIT:	INCH	Material:	
				Drawn:		Scale:	1=1	Part Title:	
4				Checked:		PROJECT		PART NO.	20105
3				Approved:					
2				<p>MIDLAND METAL MFG. CO. KANSAS CITY, MO</p>				DWG. NO.	
1									
NO.	PCA	Date	Revision	<p>TOLERANCES ARE: DECIMALS. .X:±0.03 .XX:±0.01 .XXX:±0.005 ANGLES:±1° FRACTIONS ± 1/8</p>					