



ZURN PEX®

Commercial Plumbing and Layout Guide

Installation Instructions



1.855.ONE.ZURN | ZURN.COM



TABLE OF CONTENTS

SECTION	PAGE NO.	SECTION	PAGE NO.
The Zurn PEX Commercial Plumbing System	2	Connecting Zurn PEX to Fixtures	13
Zurn PEX Insert Fitting System	3	Fire-Rated Wall Penetrations with Zurn PEX Tube	18
Zurn Crimp Systems	4	PEX Plumbing System Options	20
Large Diameter Compact Copper Crimp Tool		Risers	26
Operating Instructions (QCRTLDM)	5	Public Bath Risers	29
Jaw Installation Instructions	6	Hanging and Supporting Methods	30
Zurn PEX Tubing Installation	6	NSF Standards, Descriptions, and Markings	30
Pipe Support Track	7	ASTM Standards and Descriptions	30
System Sizing and Design	11	Other ASTM Fitting Standards	31

The Zurn PEX Commercial Plumbing System

This manual is an addendum to the Zurn PEX Plumbing Installation Guide, ZPM07199. Its purpose is to provide additional information relevant to 1-1/4", 1-1/2", and 2" Zurn PEX piping systems, herein referred to as "Commercial Plumbing System," which is not included in the Zurn PEX Plumbing Installation Guide.

Prior to beginning installation of the Commercial Plumbing System, read thoroughly through this entire addendum, as well as the Zurn PEX Plumbing Installation Guide. The following information will be discussed in this addendum:

- Tubing
- Fitting System
- Crimp System
- Installation
- System Sizing and Design
- Connection Detail
- Commercial Construction Techniques
- Fire Resistant Construction

Zurn PEX Commercial Tubing Specifications

The following table is a list of large diameter Zurn PEX tubing for use in commercial tubing systems.

Zurn Designation	Nom. Size (CTS)	Avg. O.D.	Avg. I.D.	Min. Wall Thickness	Fluid (Gal./Foot)	Wt. Per/100' (Lbs.)
Q6P	1-1/4"	1.375"	1.054"	0.153"	0.045	26
Q7P	1-1/2"	1.625"	1.244"	0.181"	0.063	37
Q8P	2"	2.125"	1.629"	0.236"	0.108	60

Note: For complete information regarding Zurn PEX tubing, refer to the Zurn PEX Plumbing Installation Guide or Zurn PEX Plumbing and Radiant Heating Product Catalog.

Zurn PEX UV Resistance

Like most plastic materials, PEX is subject to UV deterioration and must not be exposed to sunlight, either direct or indirect. Outside storage is not recommended, but if necessary, the tubing must be covered with a material that will protect it from UV light. Failure to do so will void the warranty. However, in the circumstance that a project is delayed, Zurn PEX tubing has UV stabilizers that are designed to protect the tube for up to 6 months. In this circumstance, protective measures should still be taken to limit UV exposure.

Zurn PEX Chlorine Resistance

PEX 5306 Designation – Generally a continuously circulating hot water plumbing loop @ 140°F.

Zurn PEX Temperature and Pressure Ratings

Zurn PEX tube has the following temperature and pressure ratings:

- 160 PSI at 73°F
- 100 PSI at 180°F
- 80 PSI at 200°F

Zurn PEX in Plenums

Zurn PEX tube 2" and smaller meets the 25/50 flame spread index/ smoke density index requirements specified in building codes for use in plenums when encased with an appropriately listed 1/2" thick fiberglass insulation. Un-insulated installations using special accessories may also comply, please consult with the factory for details.

Zurn PEX Insert Fitting System

Zurn PEX is a relatively inert material and is therefore joined by mechanical connections. Zurn mechanical connections consist of an insert fitting and a clamp system to make the connection between the tubing and fitting. Insert fittings have a 30-year track record of reliability. With over 230 million fittings in service nationwide, the fitting system is the most widely used system in the industry. To suit your installation needs, Zurn offers two choices for insert fittings – Zurn PEX XL, and Zurn PEX CR.



Zurn PEX XL (1-1/4", 1-1/2", and 2"): Zurn PEX XL fittings are manufactured from a dezincification resistant low lead alloy called ECO BRASS®. It is compliant with low lead legislation in the states of California and Vermont, and listed to the following standards:

- ASTM F877
- ASTM F1807
- CAN/CSA B137.5
- NSF/ANSI Standard 14
- NSF/ANSI Standard 61, including Annex G

Zurn PEX XL (1" and smaller): Zurn PEX XL fittings are manufactured from a dezincification resistant low lead alloy called ECO BRASS®. It is compliant with low lead legislation in the states of California and Vermont and listed to the following standards:

- ASTM F877
- ASTM F1807
- CAN/CSA B137.5
- NSF/ANSI Standard 14
- NSF/ANSI Standard 61, including Annex G

Burial of XL Brass Fittings: When it is necessary to bury a fitting directly in the soil, Zurn recommends protecting the fitting and crimp ring with a heat shrink sleeve, foam pipe insulation, or several layers of plastic film such as Saran™ Wrap. Tape can be used to keep the plastic layers in place, but the tape should not come into contact with the Zurn PEX tubing. It is recommended the fittings not be buried in concrete.

Zurn PEX CR (1" and smaller): Zurn PEX CR fittings are molded from a blend of highly engineered polymers. The inherent qualities of the polymers make Zurn PEX CR fittings highly resistant to chlorine and other chemicals present in potable water. Zurn PEX CR fittings are a superior alternative to metallic fittings in areas with localized aggressive water chemistries.

Zurn PEX CR Sizes: Zurn PEX CR fittings are available in sizes up to and including 1".

Zurn PEX CR Fire Ratings: For information regarding Zurn PEX CR fire ratings, contact Zurn.

Note: For more information concerning the Zurn PEX XL or CR fitting system, such as installation and tools, refer to the Zurn PEX Plumbing and Installation Guide. Refer to the Zurn PEX Plumbing and Radiant Heating Systems Product Catalog for a list of the types of fittings available.



Zurn Crimp Systems

Zurn offers three different crimp fitting systems; however, when dealing with large diameter tube (1-1/4", 1-1/2", and 2"), it is only feasible to use the Copper Crimp Ring System on the tubing.

Copper Crimp System

The Zurn Copper Crimp System has the following benefits:



- Proven system for over 30 years
- Available for all sizes of Zurn PEX tube
- Go/No-Go Gauge for fast, simple installation
- 25-year system warranty when used with Zurn PEX tube

QuickCap™ Copper Crimp Ring with Positioning End Cap Making The Connection Using Power Tool



- Positioning stop virtually eliminates ring movement during installation, creating 360 degree seal for leak-free connections
- Indicator window provides visual confirmation tubing is fully inserted
- Dependable ASTM F1807 fitting system meets plumbing and heating code requirements

For more information concerning the Zurn Copper Crimp System such as tools, tool adjustment, installation instructions, listings, etc., refer to the Zurn PEX Plumbing and Installation Guide.

Making a Connection Using Power Tool

Large diameter tubing (1-1/4", 1-1/2", and 2") crimps will be made using the following:

- Fitting (from Zurn) of the appropriate size.
- Copper crimp ring (from Zurn) of the appropriate size.
- Power tool to make the crimp connection with the appropriate sized crimp head. Zurn offers numerous power tools, including QCRBKIT56-14V, QBJ-6, QBJ-7, and QBJ-8. Zurn power tool jaws are also compatible with the following tools: RIDGID® 330-B, Stanley® P204, Nibco® PC100, and Rothenberber ROMAX.
- Go/No-Go Gauge (from Zurn) to ensure a proper crimp. The crimp must be within the dimensional limits shown in the table below.

Tube Size 1-1/4"	1-1/2"	2"	
Crimp Minimum Diameter	1.430"	1.685"	No Min.
Crimp Maximum Diameter	1.445"	1.700"	2.203"



Zurn PEX tubing connected to copper manifolds using copper crimp rings.

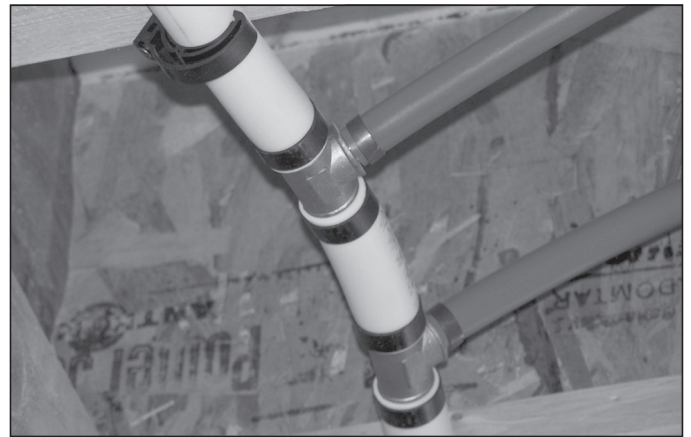

Zurn PEX large diameter tube and tee fittings shown in trunk and branch method.

Be sure to follow the Zurn PEX Plumbing Installation Guide for the procedure of making a crimp with a copper crimp ring and checking the crimp using the Go/No-Go Gauge.

Note: 2" has a "Go" Gauge only. For more information concerning the Zurn Crimp System, such as tools, tool adjustment, installation instructions, listings, etc., refer to the Zurn PEX Plumbing and Installation Guide.

Making a Soldered Connection Near PEX

When soldering near a Zurn PEX connection such as a copper stub elbow, the installer should take proper precautions to keep the Zurn PEX connection cool while soldering. There are three ways this can be done:

1. Make the solder connection prior to the crimp connection, making sure the pipe has cooled.
2. Wrapping the connection with a cold wet rag.
3. Applying an aerosol "spray type" spot freezing product to the copper.

Note: Proper placement of copper crimp ring from shoulder.

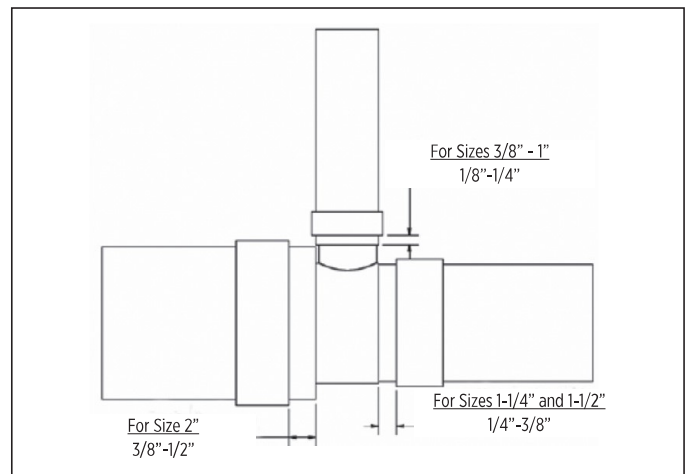

This spacing generally ensures the crimp ring is centered over the ribs of the fitting. For worry-free spacing, the QuickCap Crimp Ring with positioning stop can be used to virtually eliminate ring movement during installation.

Large Diameter Compact Copper Crimp Tool Operating Instructions (QCRTLDM)

Cutting Zurn PEX Tubing

Step 1: Measure and cut the tube. Be sure you have a square burr-free cut. An uneven or jagged cut may cause an improper connection.

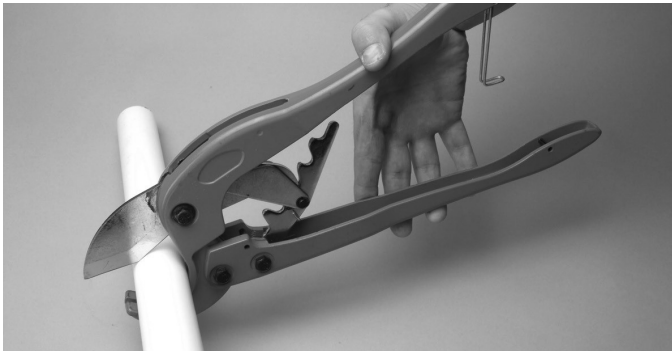

Install Copper Crimp Ring

Step 2: Slip a copper crimp ring onto the tube.



Install Fitting

Step 3: Insert the fitting into the tube up to the fitting shoulder. The copper crimp ring should be positioned 1/4"-3/8" from the end of the tube for 1-1/4"-1-1/2" sizes and 3/8"-1/2" from the end of the tube for 2" tubing.



Crimping

Step 4: Load fitting assembly into the tool. Position the tool such that the crimp ring is completely covered by the tool jaws. Confirm the tubing is at a 90° angle to the fitting and close jaw. Hand tighten the nut to hold fitting assembly in place.



Step 5: Drive the nut down with an impact wrench until blue LED light turns on.



Checking

Step 6: Check crimp using the supplied "GO Gauge."



Jaw Installation Instructions

Step 1: Open clamp, then press down on the keyed slot to loosen jaw.



Step 2: Continue to hold in the keyed slot, turn tool around and move key out of position. Remove jaw from clamp.

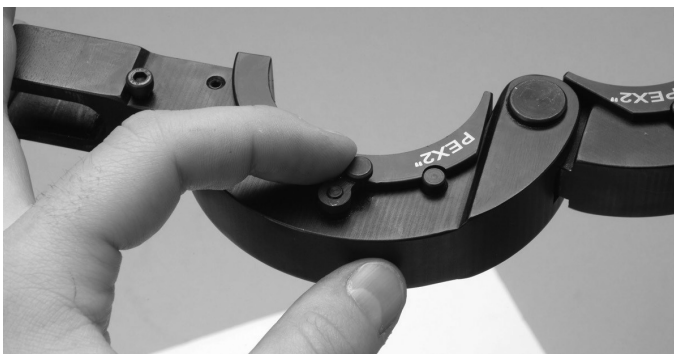

Step 3: Insert new crimping jaw.



Step 4: Rotate key back into position until key clicks to lock jaw in place. Repeat for other jaw.



Zurn PEX Tubing Installation

There are several key points that must be addressed when installing Zurn PEX tubing in a commercial plumbing system. This section will discuss these points, which will include supporting Zurn PEX tubing, penetrating metal studs, tubing expansion and contraction, bending Zurn PEX, and insulation. **Note:** This section lists only certain items that must be taken into consideration when installing Zurn PEX in a commercial system. For complete installation instructions, the installer must refer to the Zurn PEX Plumbing and Application Guide.

Supporting Zurn PEX Tubing

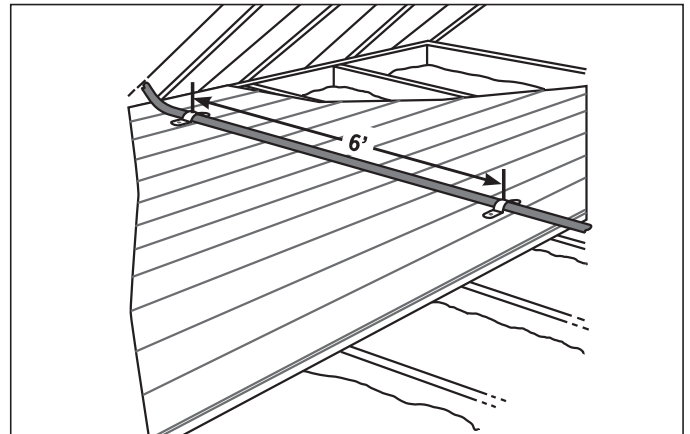

Straps can be 6 feet apart if the tube is continuously supported.

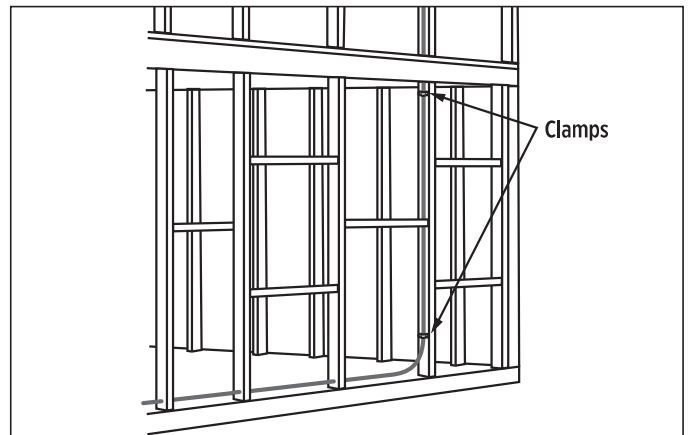

Vertical runs need supported on every floor. Depending upon the type of construction method being utilized, mid-story guides may be required (see section on Commercial Construction Methods).

Hanger Recommendations: There are numerous manufacturers who produce the accessories needed to hang/support piping in large diameter tubing systems. Below is a list of companies who produce these accessories. Contact the manufacturer for details on installation with Zurn PEX tubing.

- Cooper B-Line
- Holdrite®
- PHD Manufacturing

It is critical that all hangers are free of sharp edges to prevent damaging the tubing.

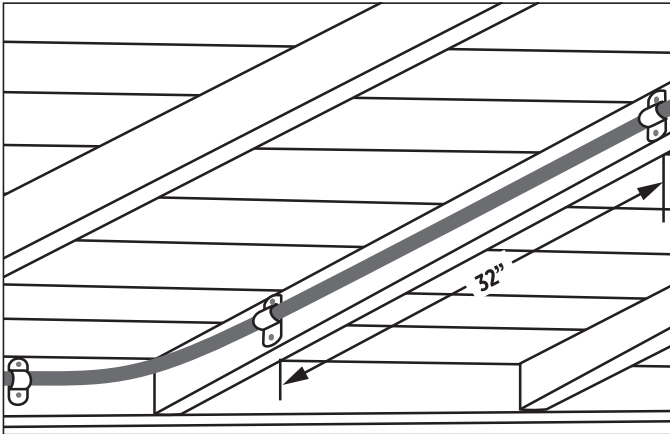

Straps can be 32 inches apart maximum in a horizontal run.

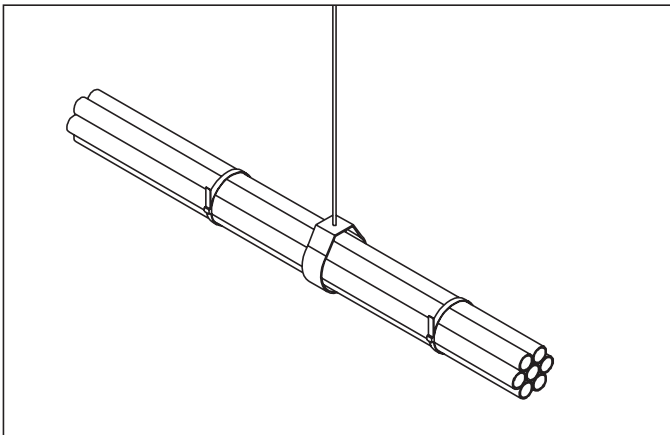

When supporting a tube bundle, use a strap to support an entire bundle.

Pipe Support Track



- Pre-galvanized steel support track is supplied in 9-foot lengths
- Extends distance between supports to hang PEX tubing like rigid piping
- Controls direction of pipe expansion
- For use with new and re-piping installations
- Pipe support track fits inside insulation

Installation Notes

- Suspended piping should be supported at intervals not to exceed 8'
- The Pipe Support Track should NOT be used with coiled tube
- Insert pipe into the Zurn PEX Pipe Support before hanging
- When using a circular saw or band saw to cut the Zurn PEX Pipe Support, place the support flat side down to make a clean cut, or place a scrap piece of pipe into the support before cutting
- When using a hand tool to cut the Zurn PEX Pipe Support, place the support flat side down and mark a line on the support track to follow
- After cutting Zurn PEX Pipe Support you must taper and smooth out any sharp edges to keep from damaging Zurn PEX tube
- Use 50 lb. cable ties or equivalent to secure Zurn PEX tube to the Support Track
- The Zurn PEX tube with Zurn PEX Pipe Support can be insulated with typical CTS (copper tube size) pipe insulation

Listings

Consult Zurn PEX for proper installation in plenum applications.

Metal Studs and Zurn PEX Tubing

It is possible during commercial construction that metal studs may be utilized. Protective sleeves or bushings should be used when penetrating metal studs. Sleeves and bushings are not required when penetrating ordinary wood or particle board if the holes are at least 1/8" larger than the tube size and tube movement is not restricted.

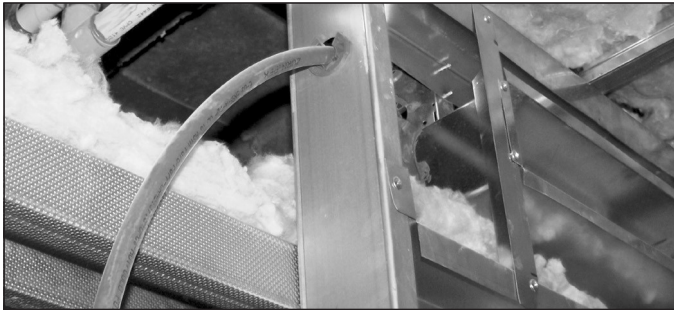

Zurn PEX tubing sleeved through steel stud for protection.

Zurn PEX Thermal Expansion and Contraction

All materials expand and contract with changes in temperature. Plastics typically expand and contract more than metals for a given change in temperature. This must be considered when installing Zurn PEX tube.

In most cases, particularly with sizes 1" or less, expansion and contraction can be compensated for by installing the tubing with slack. Do not pull Zurn PEX tubing tight during installation. Allow an extra 1/8" per foot of tube length when cutting the tube. This should cover a temperature differential (installation temperature to use temperature) from 35°F to 165°F or Δ130°F.

Special attention to expansion and contraction is required when the plumbing system has fixed points where movement cannot be allowed. Examples of fixed points include fire-rated wall penetrations (excessive movement can damage the fire stop or fittings that must stay in a specific location to align with fixture or openings in the structure).

Thermal Expansion and Hangers: Hangers and supports shall be firm, but loose enough to allow the tube to move back and forth as it expands and contracts. See figure below.

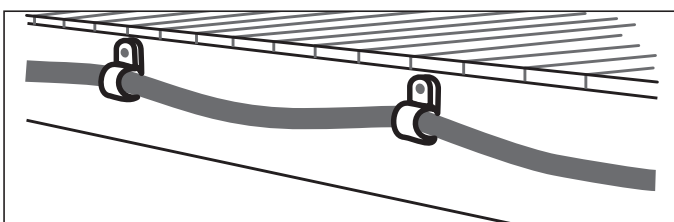

Expansion Loop/Arm: In the circumstance that slack cannot be incorporated into the plumbing line, an expansion loop or an expansion arm must be installed in the line. There are some general guidelines that must be followed when using expansion loops and arms.

- Expansion loops and expansion arms should be installed every 50 feet of straight length tubing.
- Expansion loops and expansion arms should be installed at the midpoint of two fixed points.

Note: An expansion loop/arm may not be required if there are no fixed points or restraining devices, such as the penetration of a fire rated assembly.

Expansion Arm Example: When utilizing an expansion arm, the longitudinal thermal expansion also must be taken into account. This can be done by placing the support clamps a sufficient distance away from the wall. Also, the flexible arm should be of sufficient length so the tubing cannot be damaged. Use the formula, figure, and table below to calculate the minimum length of an expansion arm:

$$L_B = 12 \times \sqrt{D \times \Delta L}$$

Where: L_B - Flexible Arm (inches)

D - Outside Diameter of Tubing (inches)

L - Tube Length (inches)

For all temperatures within the range of Δ130°F, the thermal expansion of the Zurn PEX tubing is 1/8" per foot. Therefore, the following equation can be concluded:

$$\Delta L = L \times 0.125$$

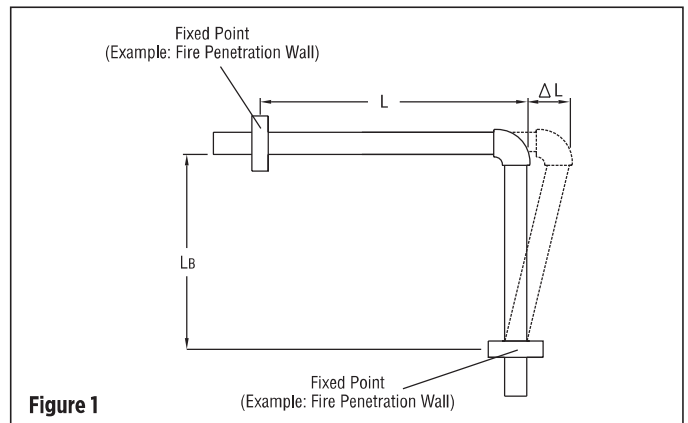

Table 1: Expansion Arm Chart (ΔT up to 130°F)

1-1/4" Zurn PEX		1-1/2" Zurn PEX		2" Zurn PEX	
L (Length of Run) Feet	L _B (Inches)	L (Length of Run) Feet	L _B (Inches)	L (Length of Run) Feet	L _B (Inches)
2	7.04	2	7.65	2	8.75
4	9.95	4	10.82	4	12.37
6	12.19	6	13.25	6	15.15
8	14.07	8	15.30	8	17.49
10	15.73	10	17.10	10	19.56
12	17.23	12	18.73	12	21.42
14	18.61	14	20.24	14	23.14
16	19.90	16	21.63	16	24.74
18	21.11	18	22.95	18	26.24
20	22.25	20	24.19	20	27.66
22	23.33	22	25.37	22	29.01
24	24.37	24	26.50	24	30.30
26	25.37	26	27.58	26	31.54
28	26.32	28	28.62	28	32.73
30	27.25	30	29.62	30	33.87
32	28.14	32	30.59	32	34.99
34	29.01	34	31.54	34	36.06
36	29.85	36	32.45	36	37.11
38	30.67	38	33.34	38	38.12
40	31.46	40	34.21	40	39.12
42	32.24	42	35.05	42	40.08
44	33.00	44	35.87	44	41.02
46	33.74	46	36.68	46	41.95
48	34.47	48	37.47	48	42.85
50	35.18	50	38.24	50	43.73

Expansion Loop Example: Calculating an expansion loop (see Figure 2) is very similar to calculating an expansion arm, in the sense that it uses a similar equation, and the result is determining the minimum lengths for the loop. The equation for the bottom portion ($L1$) of the expansion loop is shown:

$$L1 = \frac{12 \times \sqrt{D \times \Delta L}}{5}$$

The two sides ($L2$) of the expansion loop must be at least twice as long as the bottom ($L1$); therefore, the following equation can be derived:

$$(L2) = L1 \times 2$$

Once again, for all temperatures within the range of $\Delta 130^\circ\text{F}$, the thermal expansion of the Zurn PEX tubing is $1/8''$ per foot. Therefore, the following equation can be concluded:

$$\Delta L = L \times 0.125$$

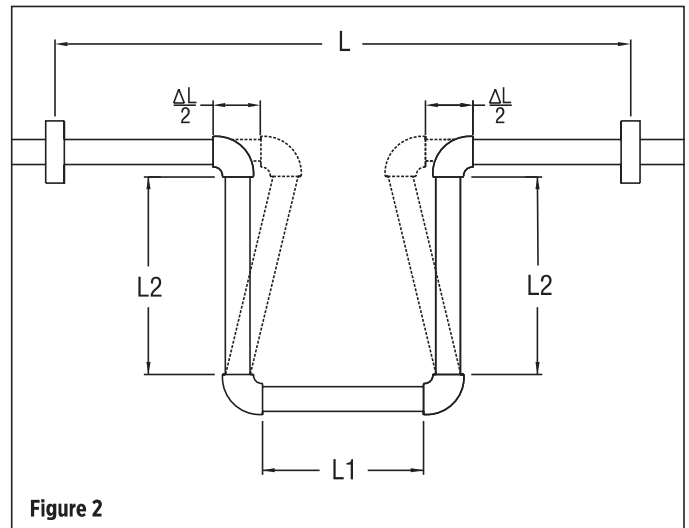

Figure 2

Table 2: Expansion Loop Chart (ΔT up to 130°F)

1-1/4" Zurn PEX			1-1/2" Zurn PEX			2" Zurn PEX		
L (Length of Run) Feet	L1 Inches	L2 Inches	L (Length of Run) Feet	L1 Inches	L2 Inches	L (Length of Run) Feet	L1 Inches	L2 Inches
6	2.44	4.87	6	2.65	5.30	6	3.03	6.06
8	2.81	5.63	8	3.06	6.12	8	3.50	7.00
10	3.15	6.29	10	3.42	6.84	10	3.91	7.82
12	3.45	6.89	12	3.75	7.49	12	4.28	8.57
14	3.72	7.45	14	4.05	8.09	14	4.63	9.26
16	3.98	7.96	16	4.33	8.65	16	4.95	9.90
18	4.22	8.44	18	4.59	9.18	18	5.25	10.50
20	4.45	8.90	20	4.84	9.67	20	5.53	11.06
22	4.67	9.33	22	5.07	10.15	22	5.80	11.60
24	4.87	9.75	24	5.30	10.60	24	6.06	12.12
26	5.07	10.15	26	5.52	11.03	26	6.31	12.61
28	5.26	10.53	28	5.72	11.45	28	6.55	13.09
30	5.45	10.90	30	5.92	11.85	30	6.77	13.55
32	5.63	11.26	32	6.12	12.24	32	7.00	13.99
34	5.80	11.60	34	6.31	12.61	34	7.21	14.42
36	5.97	11.94	36	6.49	12.98	36	7.42	14.84
38	6.13	12.27	38	6.67	13.34	38	7.62	15.25
40	6.29	12.59	40	6.84	13.68	40	7.82	15.65
42	6.45	12.90	42	7.01	14.02	42	8.02	16.03
44	6.60	13.20	44	7.17	14.35	44	8.20	16.41
46	6.75	13.50	46	7.34	14.67	46	8.39	16.78
48	6.89	13.79	48	7.49	14.99	48	8.57	17.14
50	7.04	14.07	50	7.65	15.30	50	8.75	17.49



Bending Zurn PEX

The minimum bend radius for Zurn PEX tubing is 6 times the outside diameter of the tubing when bending it with the natural curvature of the coil. If bending against the coil, the minimum radius must be multiplied by 3.

Tubing Size	Outside Diameter	Minimum Bend Radius (With Curvature of Coil)	Minimum Bend Radius (Against Curvature of Coil)
1-1/4"	1.375"	8.25"	24.75"
1-1/2"	1.625"	9.75"	29.25"
2"	2.125"	12.75"	38.25"

Insulation

Zurn PEX is resistant to freeze damage; however, installation specific variables can affect the performance of the system if it is allowed to freeze up. In general, plumbing codes specify that tubing run through attics and exterior walls should be insulated. As such, Zurn PEX tubing should be insulated according to code requirements. Insulation that is typically used in copper and CPVC installations would provide equivalent protection for Zurn PEX tubing.

Note: When using expanding foam to insulate tubing, please contact Zurn for recommendations. While many expanding foams have been tested and have shown no adverse effects to PEX tubing, Zurn cannot guarantee all foams are the same.

Pressure Testing

All Zurn PEX systems must be pressure tested in accordance with local codes.

Pressure Testing With Water: If water is used for pressure testing and the building is unheated, the system should be drained after testing to prevent freezing. Test pressure shall be at least equal to normal operating pressure but not less than 40 psi and not more than 225 PSI. Test duration should not be less than 15 minutes.

Pressure Testing With Air: If air is used for pressure testing, use a pressure no less than 40 PSI but not more than 125 PSI. The most common test pressure is 100 PSI. The system shall be tested for a minimum of 15 minutes and the pressure shall not drop more than 8 PSI in one hour. This is due to initial deformation of tube followed by slow expansion. Should the system lose over 8 PSI in one hour, repressurize and test again. Should the problem persist, refer to the leak detection instructions below. Replace the fitting and retest.

Leak Detection: Zurn PEX recommends the use of ultrasonic leak detection instruments with air tests as a leak discovery is fast and the use of chemicals solutions are not required. If you choose to use a liquid leak detector, Zurn PEX recommends the use of a diluted solution comprising of 2 ounces per gallon using any of the following three dishwashing detergents:

1. Ultra Palmolive® Original Scent
2. Joy® Dishwashing Detergent
3. Wal-Mart® Dish Detergent

This recommendation applies only to Zurn PEX systems using Zurn PEX CR polymer insert fittings or Zurn PEX XL low lead brass fittings.

Do Not use this solution on other manufacturer’s plumbing system components unless approved by the component manufacturer.

Do Not use a full strength dishwashing detergent on Zurn PEX plumbing or heating systems.

Zurn PEX, Inc. will not honor warranty claims caused by the effects of other leak detectors or chemicals applied to Zurn PEX systems.

Large Diameter Cold Weather Crimps – 1-1/4” - 2”

In cold weather conditions PEX tubing becomes stiffer, increasing the force required to make a crimp. This may occur if installed in cold weather conditions or when the product has set out overnight. Under these conditions, Zurn recommends the frequent gauging of crimped connections to ensure a good crimp has been made.

In the event a finished crimp does not gauge we recommend the connection be re-crimped following the instruction below:

1. Place the tool head jaws in the exact location of the first crimp
2. Re-crimp
3. Gauge
4. Re-crimp again if necessary

Testing has shown that it should take no more than two re-crimps to make a good crimp at temperatures as low as 5°F. Zurn does not recommend attempting to make installations at temperatures below 5°F.



System Sizing and Design

The following tables can be used to assist with designing a plumbing system using Zurn PEX.

Equivalent Tubing Length: Along with the pressure loss through the supply tubing, any pressure loss through any other components in the system must be taken into account, such as fittings, shut off valves, etc. Below is a chart that shows the equivalent length of tube in feet per one Zurn fitting.

Note: Some local codes require that water velocity through tubing cannot exceed 8 ft/s. This cut-off is highlighted on the Pressure Drop for Zurn PEX Tubing. The maximum velocity on this chart is 12 ft/s. Pressure loss in this chart is represented in PSI/foot.

Fitting Equivalent Length (Feet of Tube)							
Zurn PEX XL Fitting	Tubing Size						
	3/8"	1/2"	3/4"	1"	1-1/4"	1-1/2"	2"
Coupling	2.7	2.8	3.5	1.0	0.9	0.5	2.6
Elbow	9.2	8.0	9.2	7.8	10.0	12.5	22.1
Tee - Run	3.3	2.4	3.5	2.7	1.0	0.0	3.5
Tee - Branch	9.6	7.1	8.6	5.5	9.0	12.3	19.6

Fitting Equivalent Length (Feet of Tube)			
Zurn PEX CR Fitting	Tubing Size		
	1/2"	3/4"	1"
Coupling	6.4	6.9	4.1
90° Elbow	13.5	15.5	17.4
Tee - Run	5.9	7.0	6.2
Tee - Branch	12.3	14.9	16.1

Pressure Drop for Zurn PEX Tube – psi/foot														
GPM	3/8"		1/2"		3/4"		1"		1-1/4"		1-1/2"		2"	
	Pressure Drop	Velocity (ft/sec)	Pressure Drop	Velocity (ft/sec)	Pressure Drop	Velocity (ft/sec)	Pressure Drop	Velocity (ft/sec)	Pressure Drop	Velocity (ft/sec)	Pressure Drop	Velocity (ft/sec)	Pressure Drop	Velocity (ft/sec)
0.5	0.020	1.7	0.004	0.9	0.001	0.5	0.000	0.3	0.000	0.2	0.000	0.1	0.000	0.1
1	0.070	3.3	0.016	1.8	0.003	0.9	0.001	0.5	0.000	0.4	0.000	0.3	0.000	0.2
1.5	0.149	5.0	0.034	2.7	0.006	1.4	0.002	0.8	0.001	0.6	0.000	0.4	0.000	0.2
2	0.254	6.7	0.057	3.6	0.011	1.8	0.003	1.1	0.001	0.7	0.001	0.5	0.000	0.3
2.2	0.303	7.3	0.069	4.0	0.013	2.0	0.004	1.2	0.001	0.8	0.001	0.6	0.000	0.3
2.5	0.384	8.3	0.087	4.5	0.016	2.3	0.005	1.4	0.002	0.9	0.001	0.7	0.000	0.4
3	0.538	10.0	0.122	5.4	0.023	2.7	0.007	1.6	0.003	1.1	0.001	0.8	0.000	0.5
4			0.207	7.2	0.039	3.6	0.011	2.2	0.004	1.5	0.002	1.1	0.001	0.6
5			0.313	9.1	0.058	4.5	0.017	2.7	0.006	1.8	0.003	1.3	0.001	0.8
6			0.439	10.9	0.082	5.4	0.024	3.3	0.009	2.2	0.004	1.6	0.001	0.9
7			0.583	12.7	0.109	6.4	0.032	3.8	0.012	2.6	0.005	1.8	0.001	1.1
8					0.139	7.3	0.041	4.4	0.015	2.9	0.007	2.1	0.002	1.2
9					0.173	8.2	0.051	4.9	0.019	3.3	0.009	2.4	0.002	1.4
10					0.210	9.1	0.062	5.5	0.023	3.7	0.010	2.6	0.003	1.5
11					0.251	10.0	0.074	6.0	0.028	4.0	0.012	2.9	0.003	1.7
12					0.294	10.9	0.087	6.6	0.033	4.4	0.015	3.2	0.004	1.8
13					0.341	11.8	0.101	7.1	0.038	4.8	0.017	3.4	0.005	2.0
14							0.116	7.7	0.044	5.1	0.020	3.7	0.005	2.2
15							0.132	8.2	0.049	5.5	0.022	4.0	0.006	2.3
16							0.148	8.8	0.056	5.9	0.025	4.2	0.007	2.5
17							0.166	9.3	0.062	6.3	0.028	4.5	0.007	2.6
18							0.184	9.9	0.069	6.6	0.031	4.8	0.008	2.8
19							0.204	10.4	0.077	7.0	0.034	5.0	0.009	2.9
20							0.224	11.0	0.084	7.4	0.038	5.3	0.010	3.1
21							0.245	11.5	0.092	7.7	0.041	5.5	0.011	3.2
22							0.267	12.1	0.100	8.1	0.045	5.8	0.012	3.4
23									0.109	8.5	0.049	6.1	0.013	3.5
24									0.118	8.8	0.053	6.3	0.014	3.7



System Sizing and Design, continued

Pressure Drop for Zurn PEX Tube – psi/foot														
GPM	3/8"		1/2"		3/4"		1"		1-1/4"		1-1/2"		2"	
	Pressure Drop	Velocity (ft/sec)	Pressure Drop	Velocity (ft/sec)	Pressure Drop	Velocity (ft/sec)	Pressure Drop	Velocity (ft/sec)	Pressure Drop	Velocity (ft/sec)	Pressure Drop	Velocity (ft/sec)	Pressure Drop	Velocity (ft/sec)
25									0.127	9.2	0.057	6.6	0.015	3.8
26									0.137	9.6	0.061	6.9	0.016	4.0
27									0.147	9.9	0.066	7.1	0.018	4.2
28									0.157	10.3	0.070	7.4	0.019	4.3
29									0.167	10.7	0.075	7.7	0.020	4.5
30									0.178	11.0	0.080	7.9	0.021	4.6
31									0.189	11.4	0.085	8.2	0.023	4.8
32									0.201	11.8	0.090	8.4	0.024	4.9
33											0.095	8.7	0.026	5.1
34											0.101	9.0	0.027	5.2
35											0.106	9.2	0.028	5.4
36											0.112	9.5	0.030	5.5
37											0.118	9.8	0.032	5.7
38											0.124	10.0	0.033	5.9
39											0.130	10.3	0.035	6.0
40											0.136	10.6	0.036	6.2
41											0.142	10.8	0.038	6.3
42											0.149	11.1	0.040	6.5
43											0.155	11.4	0.042	6.6
44											0.162	11.6	0.044	6.8
45											0.169	11.9	0.045	6.9
46											0.176	12.1	0.047	7.1
47													0.049	7.2
48													0.051	7.4
49													0.053	7.5
50													0.055	7.7
51													0.057	7.9
52													0.059	8.0
53													0.061	8.2
54													0.064	8.3
55													0.066	8.5
56													0.068	8.6
57													0.070	8.8
58													0.073	8.9
59													0.075	9.1
60													0.077	9.2
61													0.080	9.4
62													0.082	9.5
63													0.085	9.7
64													0.087	9.9
65													0.090	10.0
66													0.092	10.2
67													0.095	10.3
68													0.097	10.5
69													0.100	10.6
70													0.103	10.8
71													0.105	10.9
72													0.108	11.1
73													0.111	11.2
74													0.114	11.4
75													0.117	11.5
76													0.120	11.7
77													0.123	11.9
78													0.125	12.0

Connecting Zurn PEX to Fixtures

There are a number of options for the installer to choose from when connecting Zurn PEX to the endpoint fixture. These options depend on local code requirements and fixture types. The following are some of the options available through Zurn. All of the fittings shown below can be found in the Zurn PEX Plumbing and Radiant Heating Product Catalog (unless otherwise noted). Keep in mind that there are a variety of options one can use to connect Zurn PEX tubing to fixtures, and the below are just examples of what can be used.

Note: The QuickClamp™ is depicted in the following illustrations under the part number QCLP_X. They are part of a one tool system for sizes up to and including 1". More information can be found in the Zurn PEX Product Catalog and Zurn PEX Plumbing Installation Guide.

Water Closet Connection Example

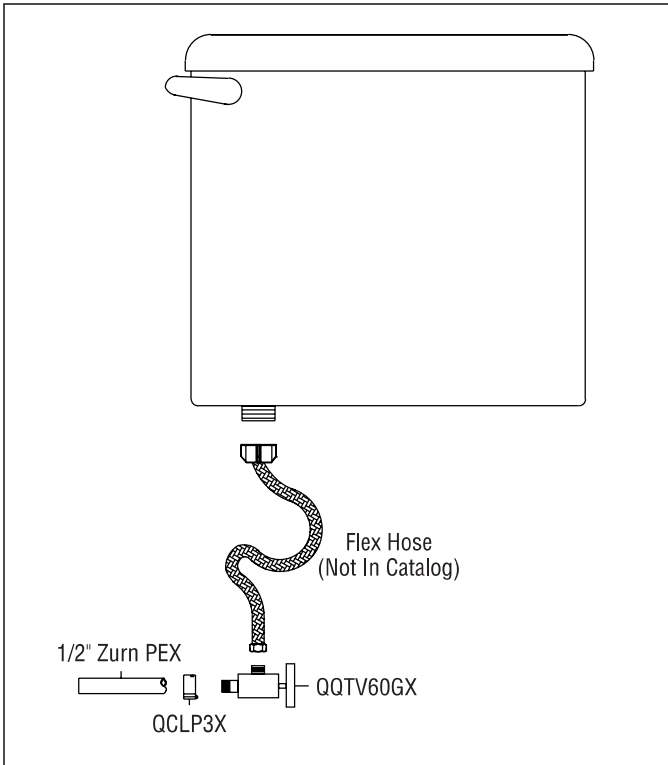

1/2" Stubout Elbow with Flange Connection Example

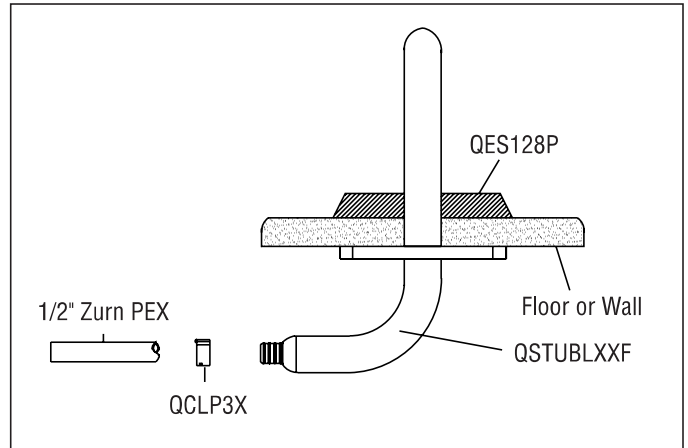

1/2" Stubout Elbow Connection Example

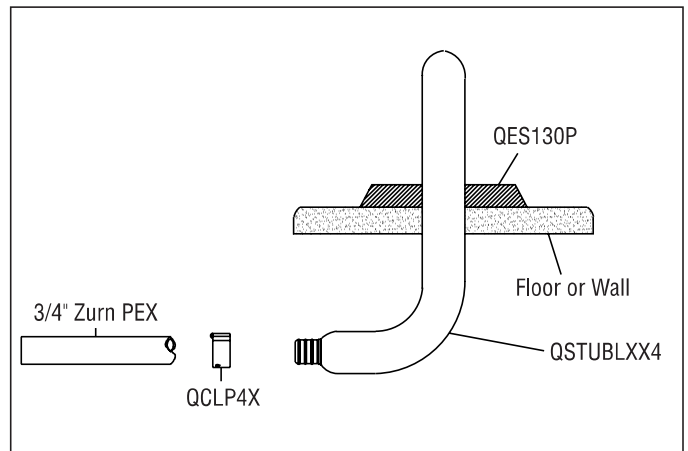

Shower/Bath Connection Example

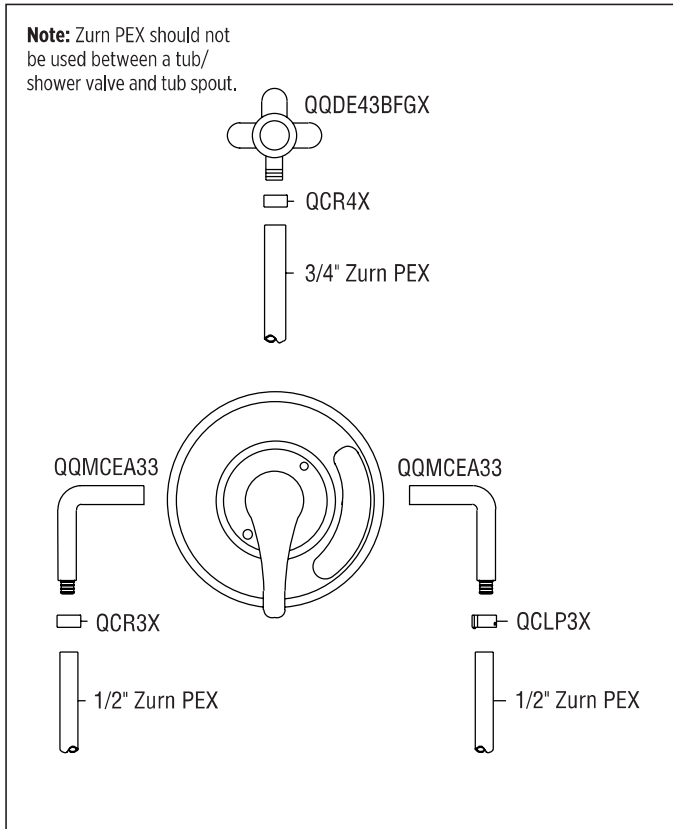

Zurn EcoVantage® Pint Urinal System Example

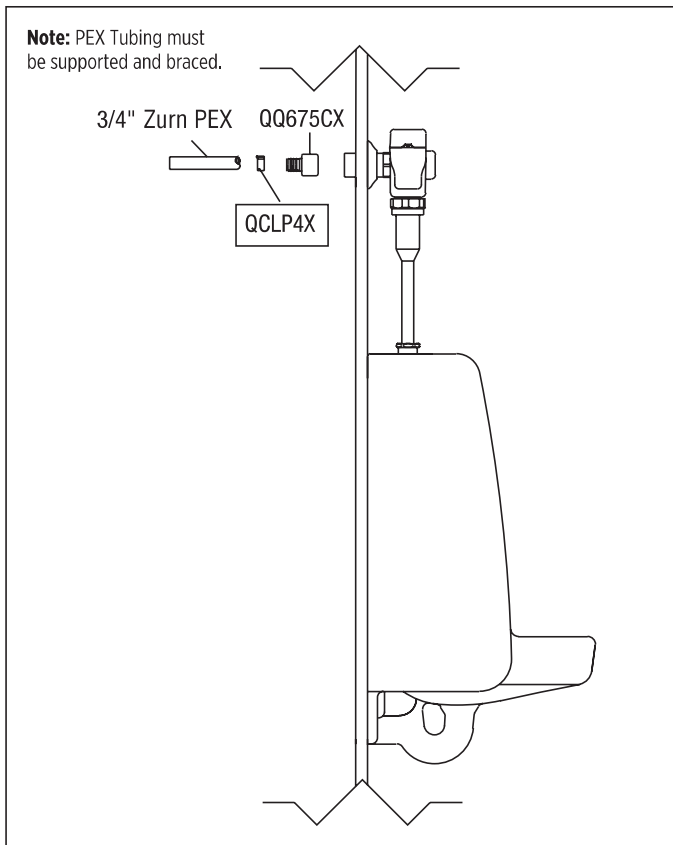

Urinal Flush Valve Operating (0.5 gpf or Less) Connection Example

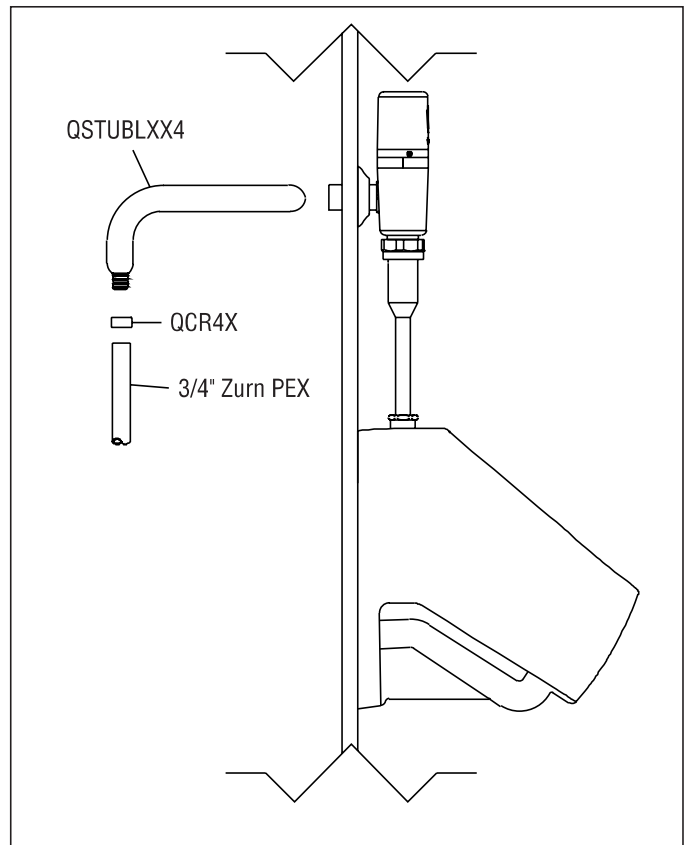

Urinal Flush Valve (Operating at 1.0 gpf or Less) Example

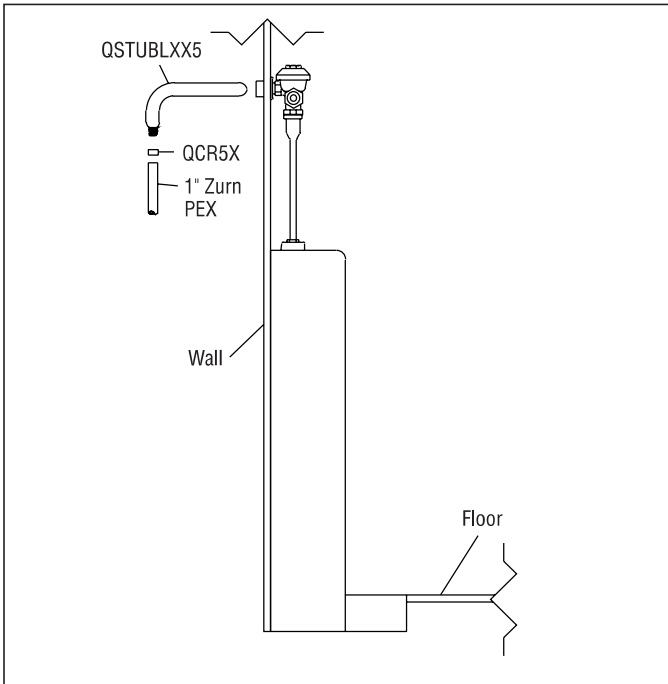

Concealed Water Closet Flush Valve (Operating at 1.6 gpf or Less) Example

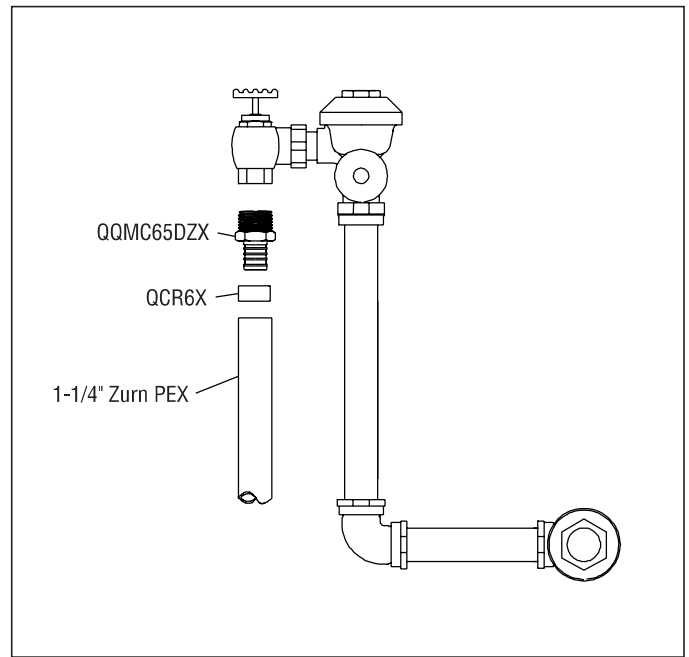

For additional information on Flush Valves, please visit www.zurn.com.

Installation Techniques With Zurn PEX Tubing in Commercial Applications

Zurn PEX is new to most commercial contractors, inspectors, and other trades. It is important that all who might be impacted by the selection of Zurn PEX as a plumbing or heating piping material be familiarized with it. Prior to installation of Zurn PEX tube, we recommend that the local plumbing and building officials be informed about the use of Zurn PEX on the job and any specific details that may be questioned are addressed. Because of its corrosion resistance and flexibility, PEX piping may be installed in a different fashion than traditional rigid piping material. For example, if the PEX tube is going to be embedded in the concrete floor/ceiling slab between two layers of rebar, it is important to coordinate with the rebar installer so that time is allowed for the PEX installation and that the rebar installer knows to take care and not damage the PEX tube when installing the second layer of rebar.

PEX can be used in all types of building construction such as structural column, shear wall, and wood frame. PEX may also be used in different types of plumbing systems such as main and branch systems, central manifold or homerun systems, and remote manifold systems. The plumbing system chosen will depend on the intended use of the building and other considerations such as lowest installed cost, most efficient water use, etc.

Commercial Building Considerations

Plumbing System Design

Selection of the type of plumbing system to be used in a building is usually the responsibility of the Architect, Engineer or Mechanical Contractor. The decision will be influenced by the intended use of the building, type of construction, and other factors such as lowest installed cost, most efficient use of water, lowest energy losses, etc. The most common types of PEX plumbing systems are:

- A. Main and Branch
- B. Central Manifold
- C. Remote Manifold

Main and Branch plumbing is the typical plumbing of rigid piping materials. PEX is effective in this type of plumbing as well and its flexibility will allow the elimination of some elbows and its availability in long coils may eliminate the need for some couplings.

A Central Manifold System (sometimes called a Homerun System) is really only practical with a flexible piping system. With this system, a hot and a cold manifold are usually located in a central location (usually near the hot water source) and smaller individual lines are run to each fixture in the building. These smaller lines are usually installed without any fittings except for the connection to the manifold and the connection to the fixture. When properly designed, these systems save water by minimizing the amount of water that is dumped down the drain while waiting on hot water to arrive at the fixture, thus save energy compared to continuously circulating hot water types of systems.

A Remote Manifold System is a variation on a Main and Branch system. A small manifold is installed near a location of several fixtures and small lines are run from the manifold to each fixture. The manifold is supplied by a larger line that is sized to meet the fixture unit demand. Since these remote manifolds are usually not close to the hot water source, this design does not provide the same water or energy savings as a Central Manifold Systems. The use of remote manifolds does tend to simplify the installation compared to typical Main and Branch type of systems.

Commercial Construction Techniques

Regardless of the actual type of building being constructed (structural column, shear wall, etc.) there are common issues with respect to installation of Zurn PEX piping.



Concrete Slabs and Floor/Ceilings

Most commercial buildings start out with a concrete slab on grade and many multi-story buildings have concrete floor/ceilings for the levels above ground. Zurn PEX tube will frequently have to pass through these concrete slabs or be embedded within them.

Pass Through

When Zurn PEX tube is in place before the concrete slab is poured, it must always be sleeved where it passes through a concrete slab to protect it from abrasion. This sleeving may be the polyethylene film sleeving commonly used on copper tubing or it may be a more substantial material to provide additional protection from damage during finishing of the concrete slab. It is also important that the Zurn PEX tube be securely located so that it does not shift from its desired location while the slab is being poured. The concrete finisher should be cautioned to not damage the tube with any power finishing equipment.

If the tube is installed through a cored or drilled hole in the slab post pour, no sleeving is necessary providing there is ample clearance and the tube is not being forced against an edge of the opening. Frequently, these openings must be sealed either for fire stopping, smoke transmission, or pests. These sealing materials must be suitable for contact with Zurn PEX tube.

Embedded in Slab

There are several things to do when the Zurn PEX tube is going to be embedded within a concrete slab. Before the job begins, a decision has to be made on whether or not the Zurn PEX tube will be installed inside a flexible corrugated conduit in slab. The advantages of using the flexible conduit are additional protection to the tube during the construction process and the ability to replace the tube if it has been damaged. The installing contractor may want to pre-sleeve the required lengths of tube before it reaches the job site. It is possible to embed Zurn PEX tube directly in the concrete without concern for corrosion. Millions of feet have been installed this way in radiant floor applications. If this option is chosen, care must be taken to make sure the tube is not damaged during or after installation because replacement is not practical once the slab is poured.

The actual routing of the tube should be marked on the floor deck to be sure there is no misunderstanding. Care should be given to assure that the tube is in locations that give plenty of clearance to any planned openings in the slab and any locations where the slab will be drilled for anchors later in construction or finalization of the building design.

Next, the rebar is typically installed and then the Zurn PEX tube is laid out and attached to the rebar following the routing marked on the floor deck. The tube, or the tube inside the conduit, should be fastened to the rebar every 32". This can be done using wire fasteners. Fasteners and tools are available from Zurn PEX. Care should be taken to assure that the tube is not pinched or deformed by these wire fasteners. When laying out the Zurn PEX tube, be sure to leave ample length at each end to connect to the intended manifold, fixture or fitting at a later time. Once the tube has been installed, the second layer of rebar if required can be installed. The rebar installers must be trained not to walk on or otherwise damage the installed Zurn PEX tube.

DO NOT EMBED ANY FITTINGS IN THE CONCRETE SLAB! All fittings and connections must be made outside of the slab.

Zurn PEX tube must be sleeved or protected from abrasion where it enters and leaves a slab. Since the tube usually is bent to enter or leave the slab, conduit elbows such as the QHCE_ in the Zurn PEX catalog are frequently used for this purpose. The elbows also provide protection during the finishing of the slab after the pour. Other acceptable sleeves include polyethylene film sleeving or corrugated conduit. These sleeves should extend at least 6" into the slab and 6" above the finished level

of the slab. Once the slab has been poured and cured, the excess sleeving may be trimmed being very careful not to damage the Zurn PEX tube inside.

Prior to the pouring of the slab, the installed Zurn PEX tubing must be pressure tested. Refer to Pressure Testing earlier in this guide. The system must be pressurized during the pour. This will provide notification if the tube is damaged during the pour.

Piping in Framing

The two common framing materials used in commercial construction are metal and wood. Metal is usually required for non-combustible construction. Wood is frequently used in combustible construction and may be used in some fire-rated construction. Some piping will almost always have to be run through the framing of a building.

Metal Framing

When Zurn PEX tube is run through metal framing members, care must be taken to prevent damaging the tube by contact with sharp edges of the metal framing material. Plastic bushings sized for the tube being installed should be used in the holes in the metal framing. If bushings cannot be used, the tubing must be protected with a heavy plastic sleeve or insulation that is resistant to cutting. Always be sure to comply with the building code with respect to the size and number of holes or notches being cut into framing members.

Wood Framing

When Zurn PEX tube is run through wood framing members, the holes in the wood should be at least 1/8" larger in diameter than the Zurn PEX tube. This will give ample clearance to allow the tube to expand and contract with changes in temperature. The edges of the wood are not abrasive to the Zurn PEX tube. Always be sure to comply with the building code with respect to the size and number of holes or notches being cut into framing members.

If Zurn PEX tube is being run through prefabricated or engineered wood trusses, care should be taken to make sure that the tube does not come in contact with any of the metal gussets that might have been used in the construction of these trusses.

Regardless of the framing material, if the tubing is installed within 2" of a nailing surface, a steel protective plate should be installed on the framing member to protect the tube from damage when drywall is installed or nailing by the building occupant.

Vertical Piping Between Floors

In multi-story commercial buildings, it is typically necessary to run main lines vertically. These mains may be installed in vertical chases or they may pass through concrete floors in pre-formed or cut holes. There is almost always a cold water main or riser and frequently there will be a hot water main or riser as well. With these mains or risers, it is important to support the weight of the tube and control the expansion and contraction so that excessive stresses or deflections are not applied to any branch lines off the risers.

Vertical Zurn PEX piping must be supported at the floor on every floor of the building and at the ceiling of every other floor (see illustration) using epoxy coated pipe clamps. These pipe clamps must not distort the Zurn PEX tube and must not have sharp edges that could cut the tube. There should also be a mid-story guide (see illustration). These supports and mid-story guide are required even if the piping is in a vertical chase. Installing the main riser tube in this manner limits the length of tube for which expansion and contraction have to be considered and controls the amount of vertical displacement that any branch lines off the riser will experience.

Installation Techniques with Zurn PEX Tubing in Commercial Applications

**Example of Copper Manifold (QCM43-_GX)
 in Commercial Construction**

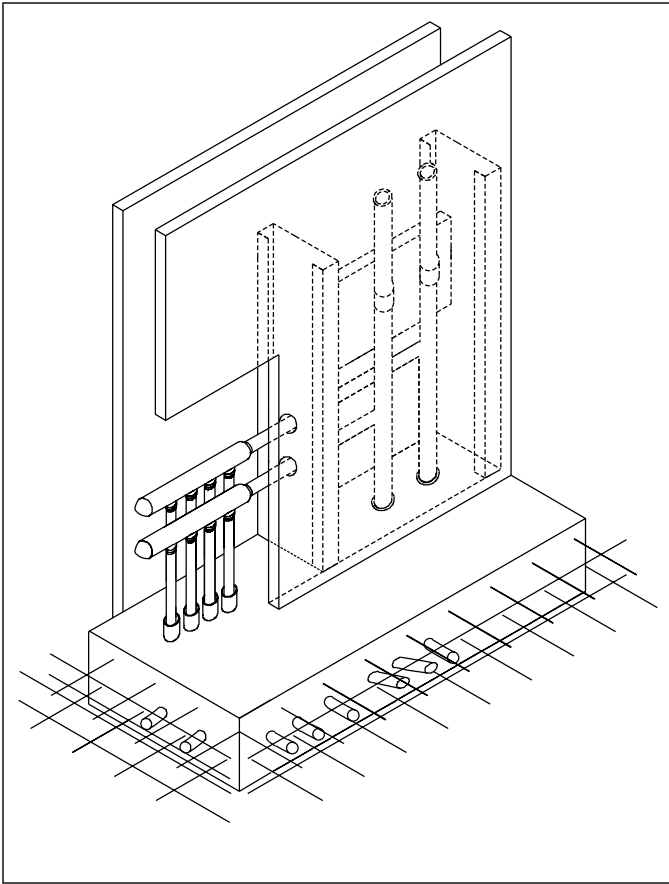

**Example of Fixture Supply
 in Commercial Construction**

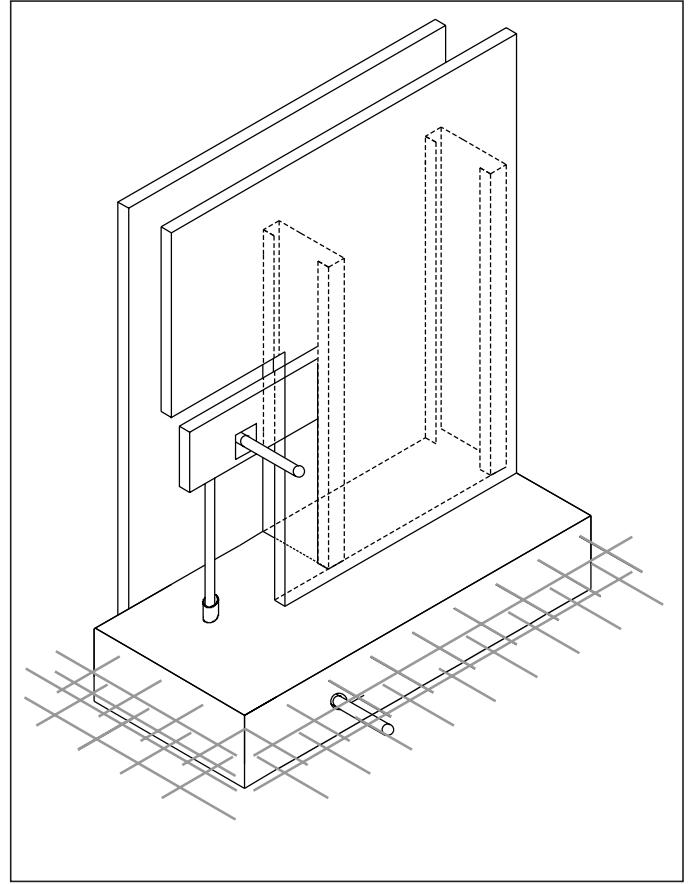

Example of Vertical Piping Between Floors

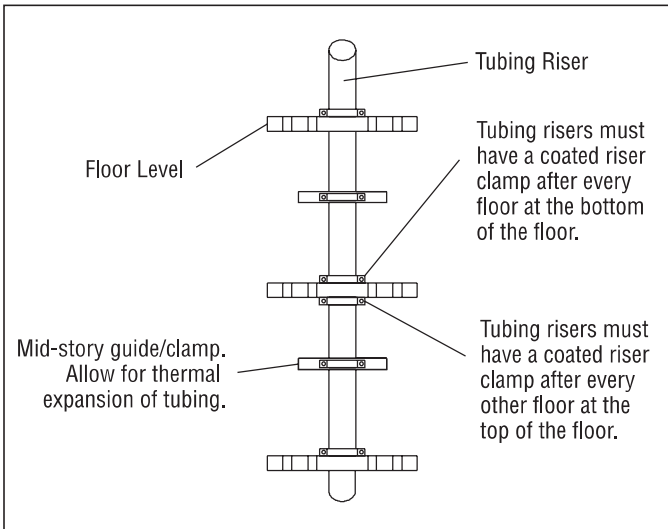

Fire-Rated Wall Penetrations with Zurn PEX Tube

Fire-rated wall penetration with Zurn PEX tube must be done in a way that doesn't compromise the integrity of the fire-rated wall. The type of sealant or seal used depends on the rating of the wall. The most common fire-rated wall assemblies are:

1. One-hour wood-frame floor/ceiling assemblies
2. One- and two-hour concrete floor/ceiling unrestrained (and restrained) assemblies
3. One-hour wood-stud/gypsum wallboard wall assemblies
4. One-hour steel-stud/gypsum wallboard wall assemblies

Firestop Manufacturers

There are numerous firestop manufacturers who have tested their products with PEX tubing. These tests establish the installation procedures for installing the firestop/sealant around the PEX tubing at the penetration. The firestop/sealant manufacturer's recommended installation procedures must be followed in order to maintain the integrity of the fire-rated wall.

Below is a list of companies who Zurn is aware of that manufacture firestop/sealants. The firestop/sealant manufacturer must be contacted to determine the proper product for a given application.

If Zurn PEX tubing is penetrating through a fire resistant construction and requires firestop assemblies, the installer must consider the following:

- The firestop system being used must be compatible for Zurn PEX tubing.
- The firestop system must be suitable for the assembly.
- The firestop system complies with all local and regional codes.
- Using a smaller penetration through the floor for the firestop will result in a cost savings. This is typically done when utilizing PEX.

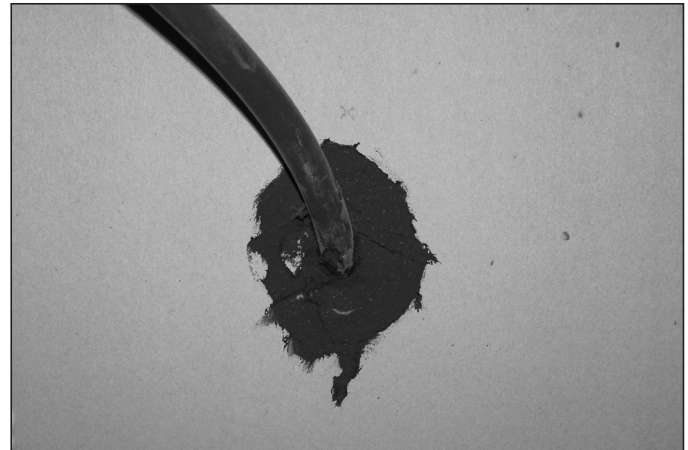

Zurn PEX tubing shown running through a fire rated wall and sealed with a fire stop sealant.

Company	Website	Products
3M	www.3m.com/firestop	Various
AD Fire Protection Systems	www.adfire.com	Various
Hercules Chemical Company	www.herchem.com	Plumbers Firestop Sealant
Hilti	www.us.hilti.com	FS One Sealant
Hilti	www.us.hilti.com	FS One Sealant
Nelson Firestop Products	www.nelsonfirestop.com	LBS3 Sealant
Passive Fire Protection Partners	www.firestop.com	WS-1 Wrap Strip
Presealed Systems	presealedsystems.com	PS-CP

Firestop Penetrations

Below are several diagrams that illustrate basic firestop penetrations with PEX tubing. These diagrams are intended as examples only and will vary depending upon the firestop manufacturer. For detailed information concerning penetration of firestops in different applications, contact the firestop manufacturer. Firestops must be installed per the installation instructions of the manufacturer.

Wrap Strip Through Wall

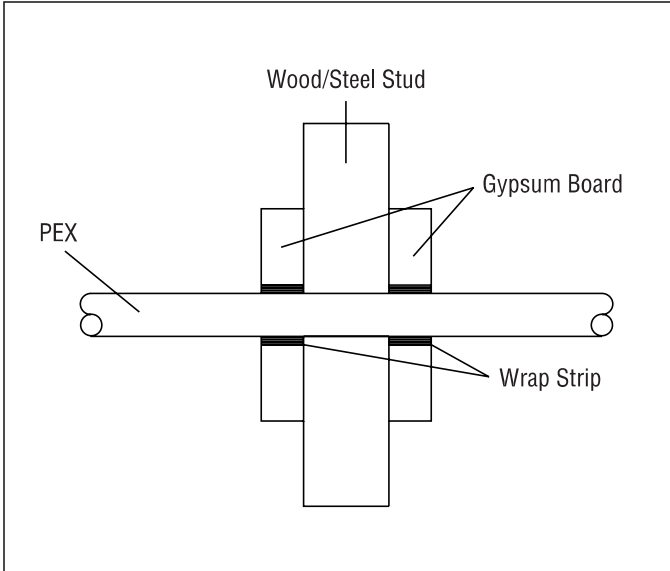

Fire Resistant Caulking Through Floor

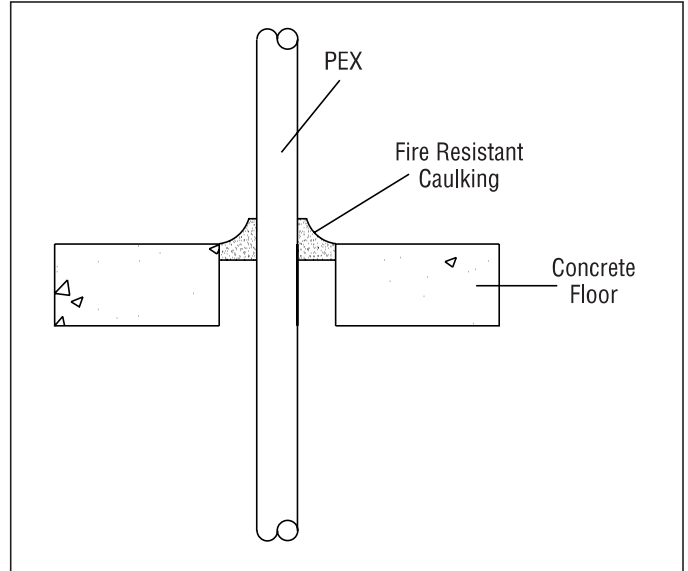

Fire Resistant Caulking Through Wall

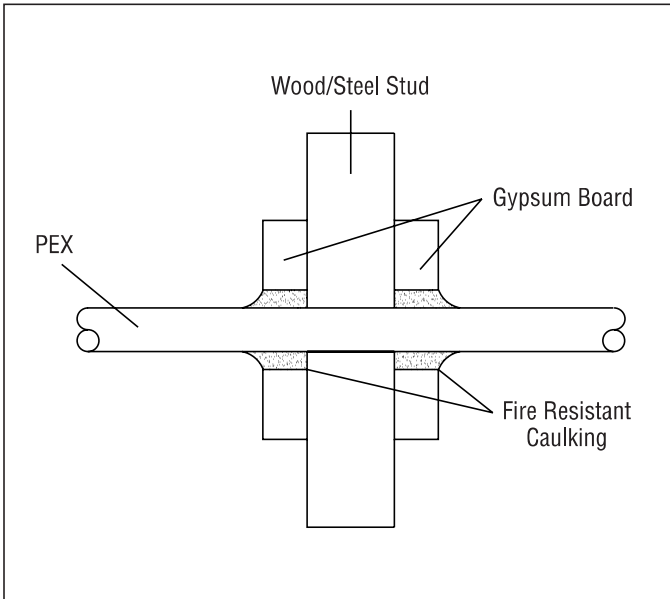

PEX Bundle Through Floor

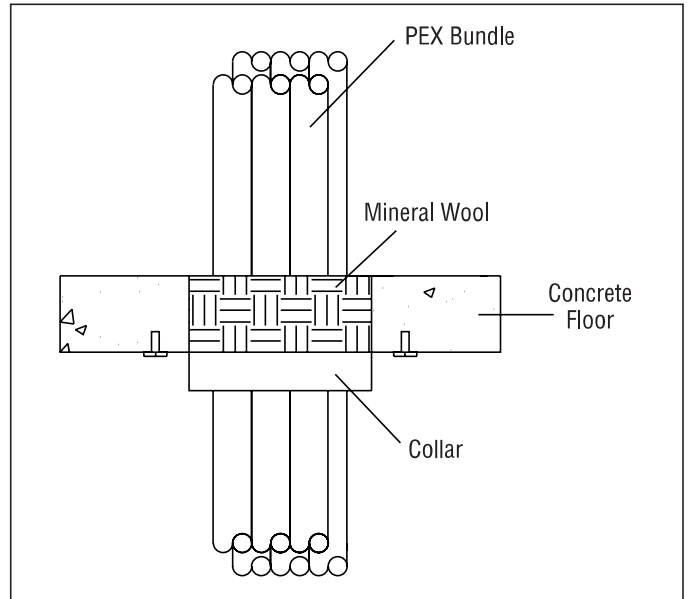



Designing a PEX System

We understand that designing and plumbing with Zurn PEX tubing may be a new experience for you. Within this design guide we will present examples of how the benefits and advantages of Zurn PEX provide additional installation options. All options are assuming a central hot water source, rather than a water heater. Additionally, the various stubouts, hanging, and supporting methods with Zurn PEX will be shown.

Please note that pipe sizes indicated are for the purposes of the example. The proper tube size is best left up to the discretion of the specifying design engineer and their knowledge of design requirements. The layouts used are not engineered for actual use but are intended to provide examples for specifying design engineers.

As always, please check with local codes to be sure PEX is approved in your area.

PEX Plumbing System Options

Traditional Trunk and Branch Method Using Zurn PEX

Features and Benefits

- Simple design conversion from rigid piping to flexible Zurn PEX systems
- Opportunity to reduce or eliminate fittings such as couplings because of Zurn PEX long coil availability
- Opportunity to reduce or eliminate fittings such as elbows because of Zurn PEX flexibility
- Deliver hot water quicker during simultaneous fixture operation
- Generally supply one fixture at a higher pressure
- Minimal tubing required

Central Manifold (Homerun) Method Using Zurn PEX

Features and Benefits

- Easier piping runs to each fixture using smaller diameter tubing such as 1/2" and 3/8"
- Faster installation time
- Opportunity to eliminate all fittings between manifold and fixture
- Opportunity to have centrally located individual shut-offs at the manifold
- Quicker delivery of hot and cold water to fixture
- More stable pressure to each fixture when operating fixtures simultaneously
- No concealed joints
- Minimal required fittings
- Saves water

Remote Manifold Method Using Zurn PEX

Features and Benefits

- Relatively simple system design conversion from rigid systems to Zurn PEX systems
- Opportunity to reduce the number of fittings installed
- Quicker hot water delivery during sequential operation
- Opportunity to have centrally located valves to shut off manifold

For technical assistance and questions, call 1-855-ONE-ZURN.

Typical Large Apartment Layouts

Traditional Trunk and Branch Method

- Valves shall be located behind access panel within apartment closet or at specifier's desired location such as hallway access panel.
- Access panel shall be no larger than necessary for easy operation of valves.
- All fixture drops shall be 3/8" or 1/2" tube size.
- Hot water provided by central hot water source (not shown).

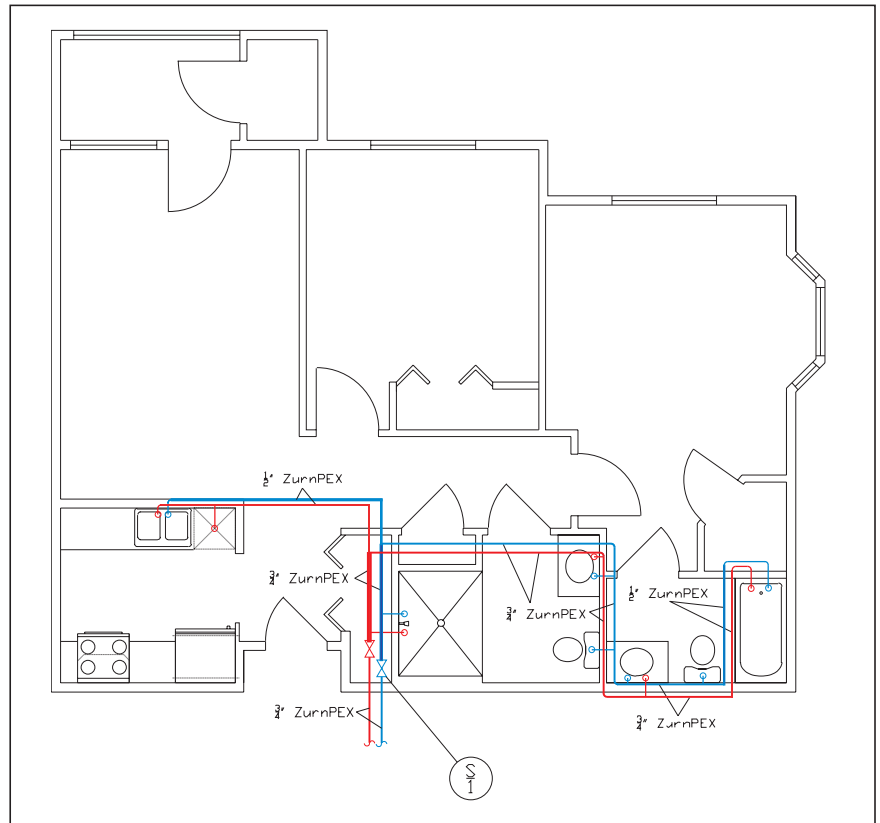

Central Manifold (Homerun) Method

- Manifold shall be installed per Zurn PEX installation instructions.
- Manifold shall be located behind access panel within apartment closet or at specifier's desired location such as hallway access panel.
- Manifold access panel shall be no larger than necessary for easy operation of valves.
- All runs from Zurn PEX manifold shall utilize 3/8" or 1/2" tubing.
- All runs shall go directly to end fixture whenever possible.
- Hot water provided by central hot water source (not shown).

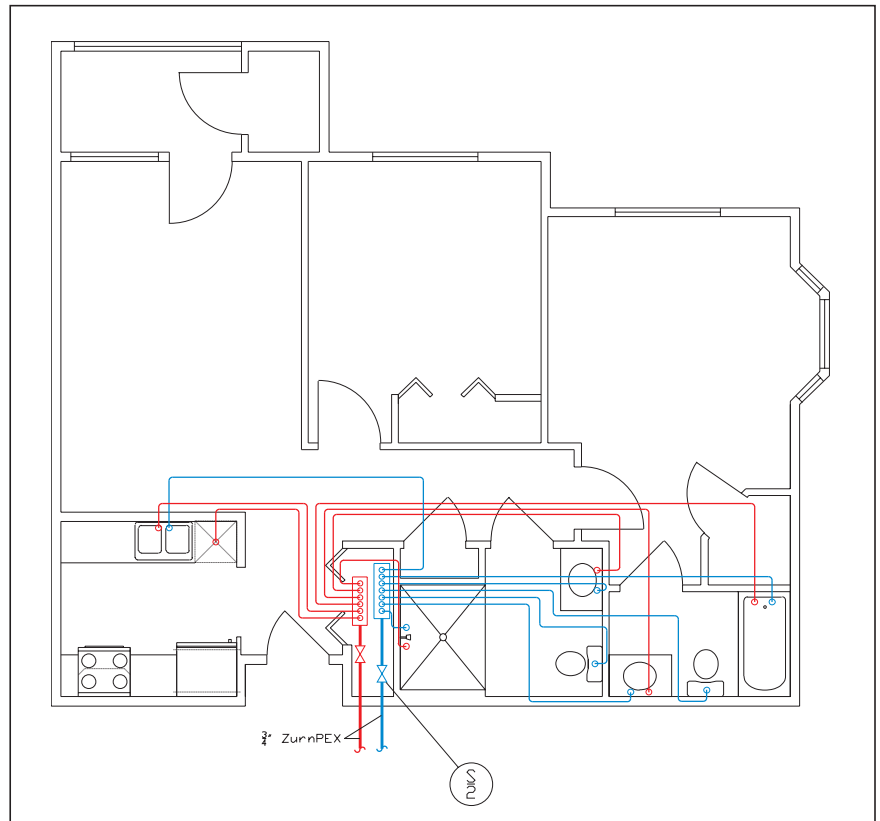

Typical Large Apartment Layout

Remote Manifold Method

- Valves shall be located behind access panel within apartment closet or at specifier's desired location such as hallway access panel.
- Access panel shall be no larger than necessary for easy operation of valves.
- All fixture drops shall be 3/8" or 1/2" tube size.
- Hot water provided by central hot water source (not shown).

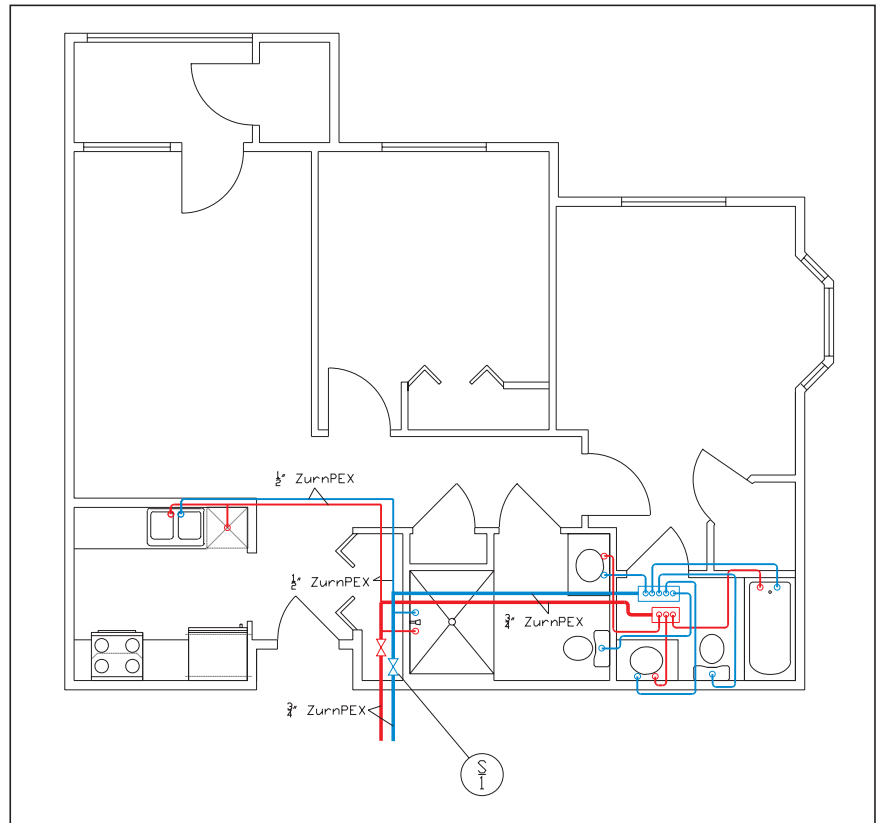

Typical Small Apartment Layout

Traditional Trunk and Branch Method

- Valves shall be located behind access panel within apartment closet or at specifier's desired location such as hallway access panel.
- Access panel shall be no larger than necessary for easy operation of valves.
- All fixture drops shall be 3/8" or 1/2" tube size.
- Hot water provided by central hot water source (not shown).

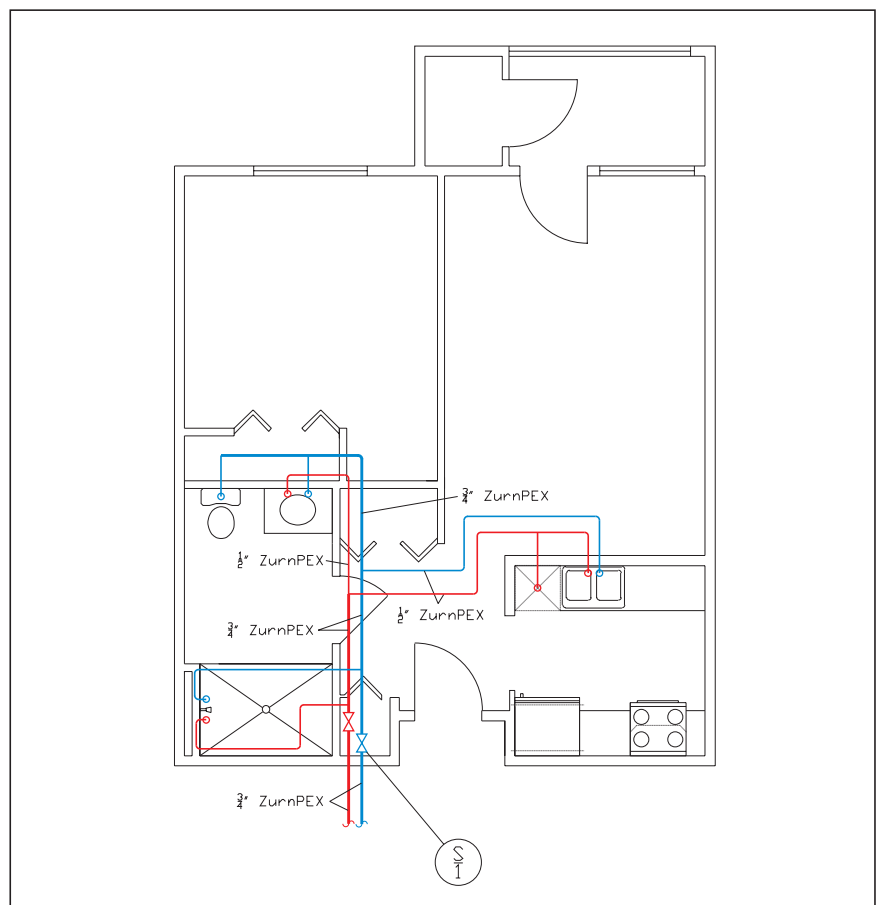

Typical Small Apartment Layouts

Central Manifold (Homerun) Method – Using QickPort® Manifolds

- Manifold shall be installed per Zurn PEX installation instructions.
- Manifold shall be located behind access panel within apartment closet or at specifier's desired location such as hallway access panel.
- Manifold access panel shall be no larger than necessary for easy operation of valves.
- All runs from Zurn PEX manifold shall utilize 3/8" or 1/2" tubing.
- All runs shall go directly to end fixture whenever possible.
- Hot water provided by central hot water source (not shown).

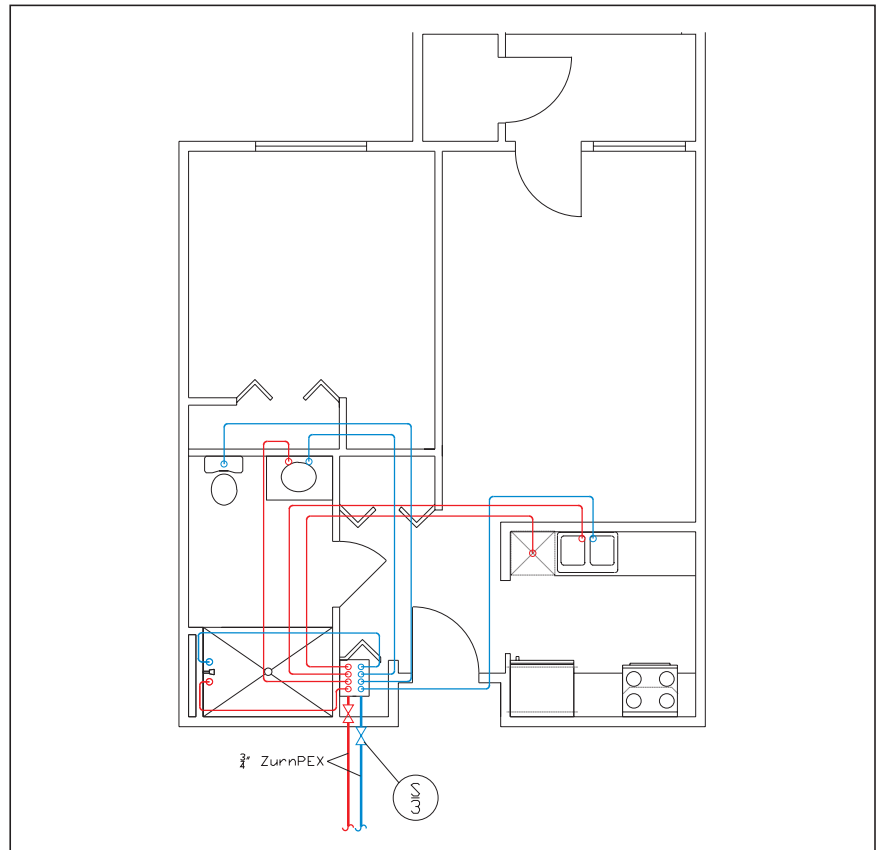

Central Manifold (Homerun) Method – Using CR Manifolds

- All runs from Zurn PEX manifolds shall utilize 1/2" tubing.
- All runs shall go directly to end fixture whenever possible.
- Hot water provided by central hot water source (not shown).

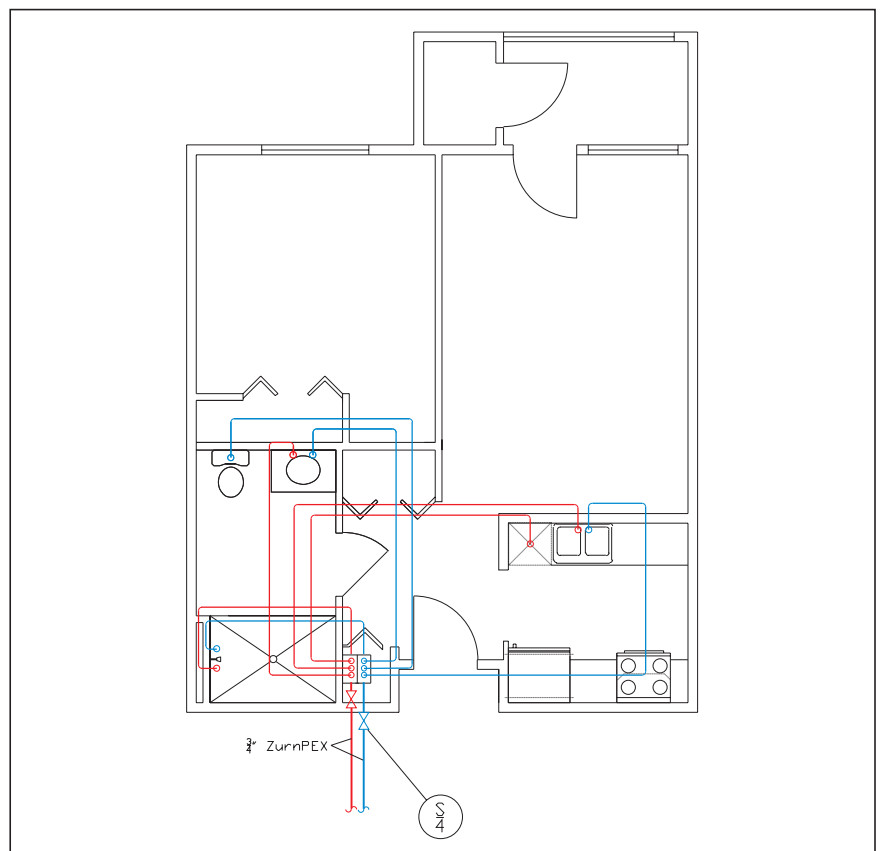

Typical Back-to-Back Hotel Room Layouts

Traditional Trunk and Branch Method

- Valves shall be located behind access panel within hotel room closet or at specifier's desired location such as hallway access panel.
- Access panel shall be no larger than necessary for easy operation of valves.
- All fixture drops shall be 3/8" or 1/2" tube size.
- Hot water provided by central hot water source (not shown).

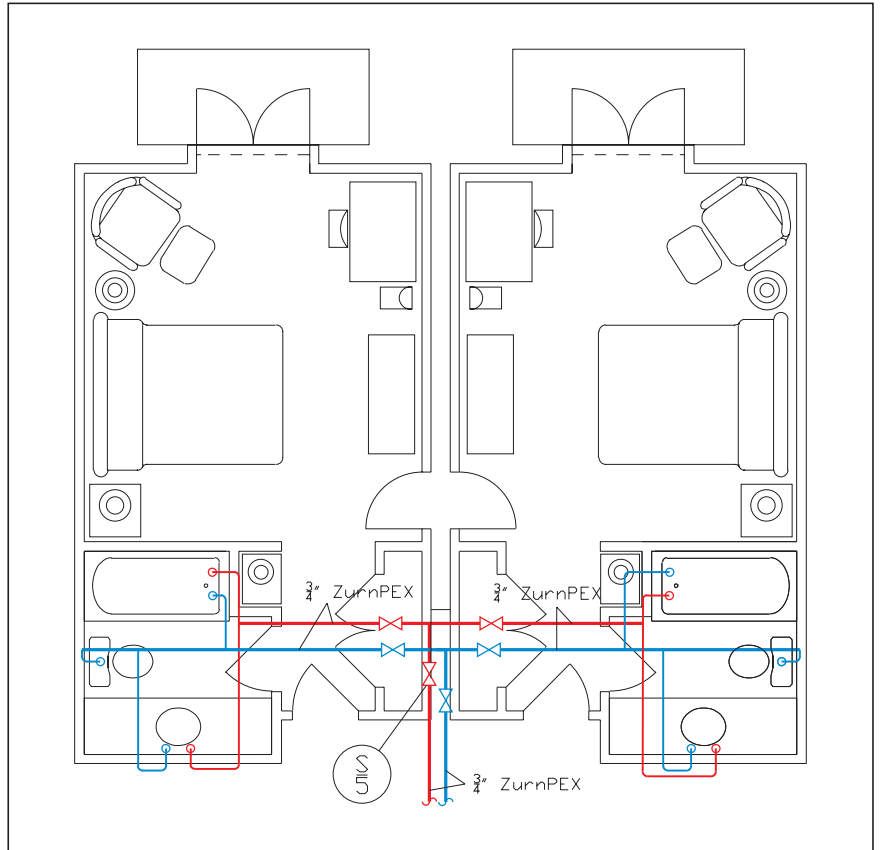

Central Manifold (Homerun) Method

- Manifold shall be installed per Zurn PEX installation instructions.
- Manifold shall be located behind access panel within hotel room closet or at specifier's desired location such as hallway or bath.
- Manifold access panel shall be no larger than necessary for easy operation of valves.
- All runs from Zurn PEX manifold shall utilize 3/8" or 1/2" tubing.
- All runs shall go directly to end fixture whenever possible.
- Hot water provided by central hot water source (not shown).

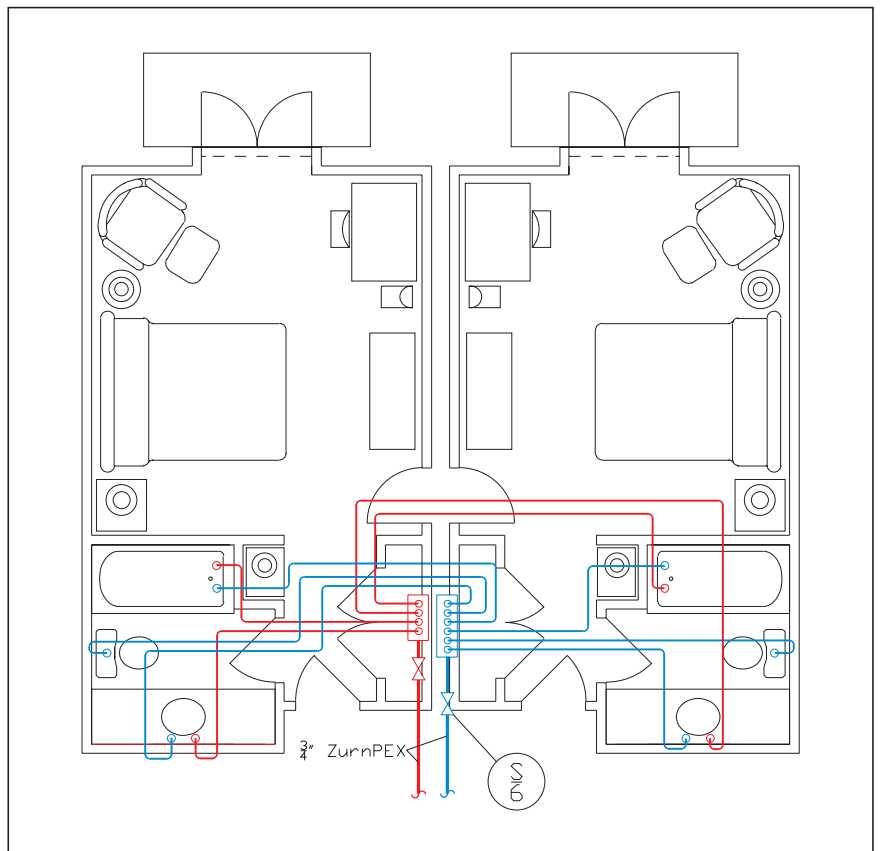

Typical Back-to-Back Hotel Room Layout

Remote Manifold Method

- Valves shall be located behind access panel within hotel room closet or at specifier's desired location such as hallway or bath.
- Access panel shall be no larger than necessary for easy operation of valves.
- All fixture drops shall be 1/2" tube size.
- Hot water provided by central hot water source (not shown).

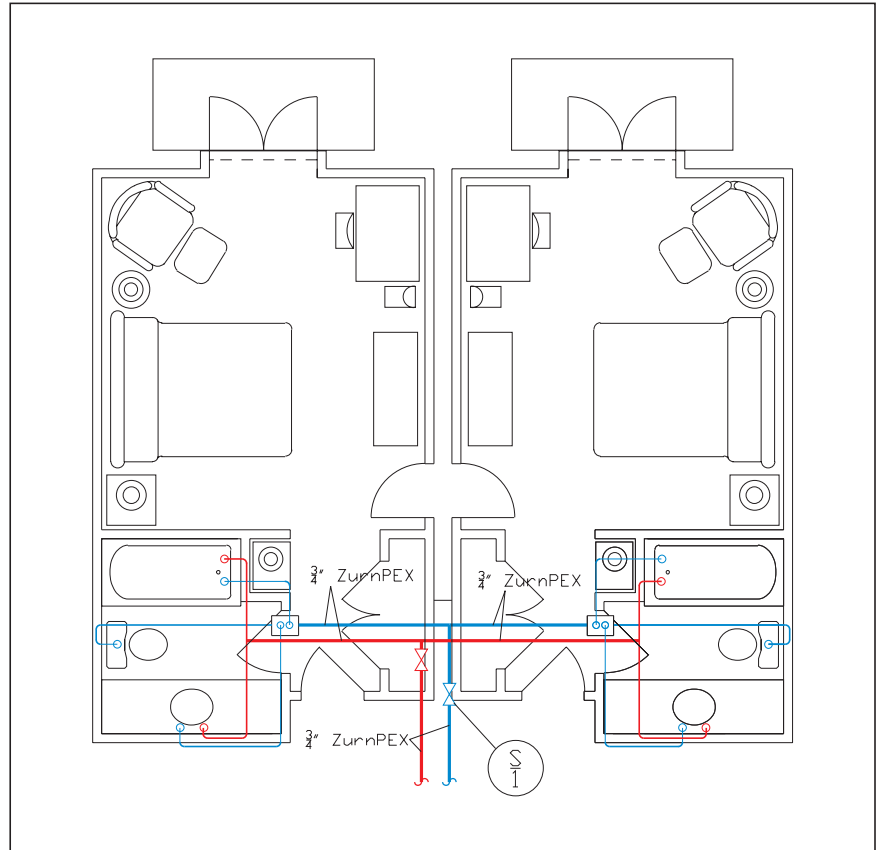

Risers

S/1		
A	QQBV44GX	3/4" x 3/4" Quarter-Turn Low-Lead Brass Ball Valves
B	QPM43-5	CR Manifold - 3/4" Inlet x (5) 1/2" Outlets
C	QPM43-3	CR Manifold - 3/4" Inlet x (3) 1/2" Outlets
A*	QQBV55GX	1" x 1" Quarter-Turn Low-Lead Brass Ball Valves

S/2		
A	QPPM6H12C-3	Preassembled QickPort Manifold - 9 Hot, 12 Cold, with 1/2" CR Valves
B	QQPSFC45X	QickPort Inlet Connection - 1" Swivel x 3/4" Barb (CR)
C	QQBV44GX	3/4" x 3/4" Quarter-Turn Low-Lead Brass Ball Valves
D	QTC3FQP	QickPort 1/2" Outlet Cap
E	QTC5FBG	QickPort 1" Outlet Cap
A*	QPPM6H12C	Preassembled QickPort Manifold - 9 Hot, 12 Cold, No Valves
A**	QQPSFC33X	1/2" CR Swivel Adaptors to Connect to QickPort Manifold Outlets
B*	QQPSFC55X	QickPort Inlet Connection - 1" Swivel x 1" Barb (CR)
C*	QQBV55GX	1" x 1" Quarter-Turn Brass Ball Valves

S/3		
A	QPPM10-3	Preassembled QickPort Manifold - 5 Hot, 5 Cold, with 1/2" CR Valves
B	QQPSFC45X	QickPort Inlet Connection - 1" Swivel x 3/4" Barb (CR)
C	QQBV44GX	3/4" x 3/4" Quarter-Turn Low-Lead Brass Ball Valves
D	QTC3FQP	QickPort 1/2" Outlet Cap
E	QTC5FBG	QickPort 1" Outlet Cap
A*	QPPM10	Preassembled QickPort Manifold - 5 Hot, 5 Cold, No Valves
A**	QQPSFC33X	1/2" CR Swivel Adaptors to Connect to QickPort Manifold Outlets
B*	QQPSFC55X	QickPort Inlet Connection - 1" Swivel x 1" Barb (CR)
C*	QQBV55GX	1" x 1" Quarter-Turn Brass Ball Valves

*Alternate Option

Risers, continued

S/4		
A	QPM43-4	CR Manifold - 3/4" Inlet x (4) 1/2" Outlets
B	QQBV44GX	3/4" x 3/4" Quarter-Turn Low-Lead Brass Ball Valves
A*	QCM43-4G	Copper Manifold - 3/4" Inlet x (4) 1/2" Outlets

S/5		
A	QQBV44GX	3/4" x 3/4" Quarter-Turn Low-Lead Brass Ball Valves
B	QQPT444X	3/4" x 3/4" x 3/4" CR Tee

S/6		
A	QPPM10-3	Preassembled QickPort Manifold - 5 Hot, 5 Cold, with 1/2" CR Valves
B	QQPSFC45X	QickPort Inlet Connection - 1" Swivel x 3/4" Barb (CR)
C	QQBV44GX	3/4" x 3/4" Quarter-Turn Low-Lead Brass Ball Valves
D	QQPT444X	3/4" x 3/4" x 3/4" CR Tee
E	QTC3FQP	QickPort 1/2" Outlet Cap
F	QTC5FBG	QickPort 1" Outlet Cap
G	QQBV33GX	1/2" x 1/2" Quarter-Turn Brass Ball Valve
A*	QPPM10	Preassembled QickPort Manifold - 5 Hot, 5 Cold, No Valves
A**	QQPSFC33X	1/2" CR Swivel Adaptors to Connect to QickPort Manifold Outlets
B*	QQPSFC55X	QickPort Inlet Connection - 1" Swivel x 1" Barb (CR)
C*	QQBV55GX	1" x 1" Quarter-Turn Brass Ball Valves

*Alternate Option



Typical Men's and Women's Bathroom Layout

Traditional Trunk and Branch Method

- Sink:** Zurn EcoVantage® Lavatory Faucet with 0.5 gpm Aerator
Model: Z6920; Qty: 4
- Urinal:** Zurn EcoVantage® 0.125 gpf The Pint®
Model: Z5798; Qty: 1
- WLC-1:** Zurn EcoVantage® 1.28 gpf – ADA Compliant
Model: Z5665; Qty: 2
- WLC-2:** Zurn EcoVantage® 1.28 gpf
Model: Z5655; Qty: 1

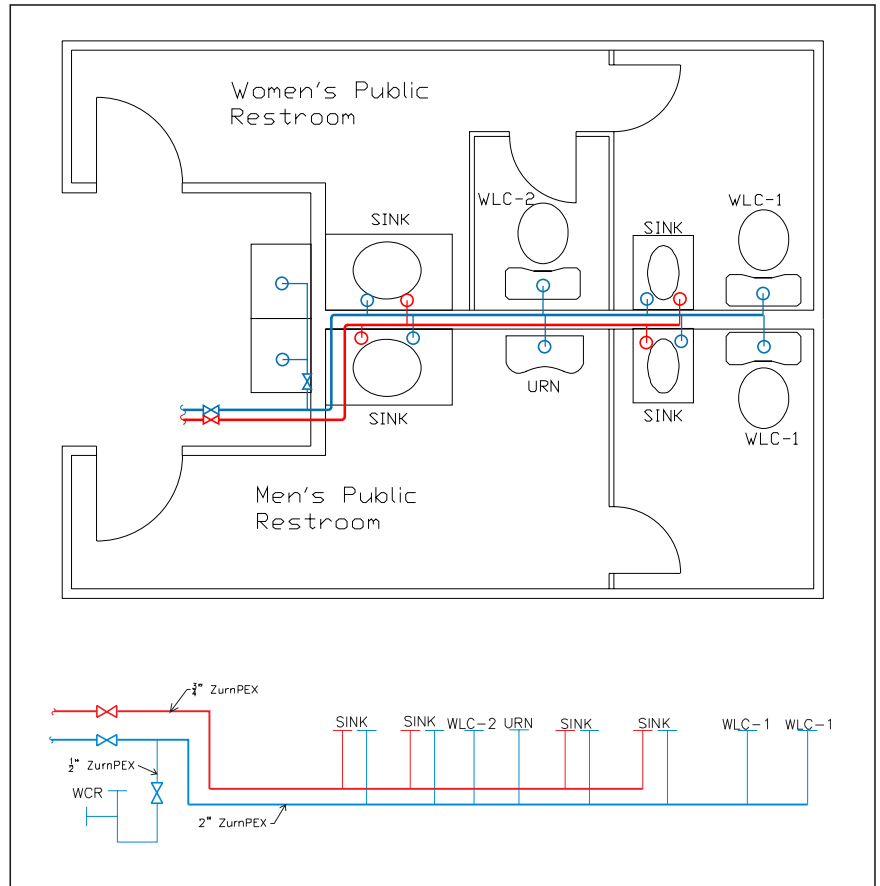

Typical Public Men's and Women's Bathroom Layout

Central Manifold (Homerun) Method

- Sink:** Zurn EcoVantage® Lavatory Faucet with 0.5 gpm Aerator
Model: Z6920; Qty: 4
- Urinal:** Zurn EcoVantage® 0.125 gpf The Pint®
Model: Z5798; Qty: 1
- WLC-1:** Zurn EcoVantage® 1.28 gpf – ADA Compliant
Model: Z5665; Qty: 2
- WLC-2:** Zurn EcoVantage® 1.28 gpf
Model: Z5655; Qty: 1

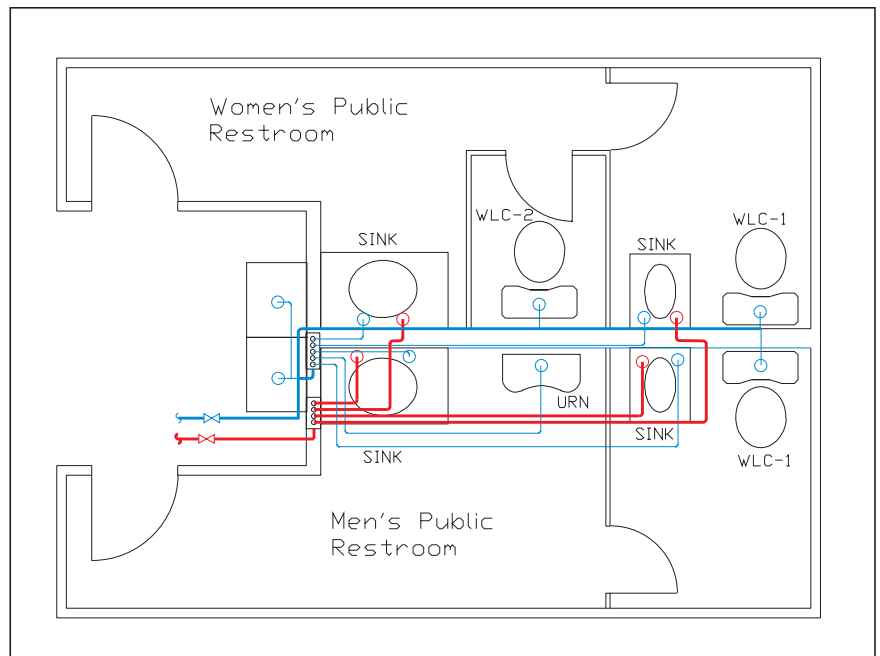

Public Bath Risers

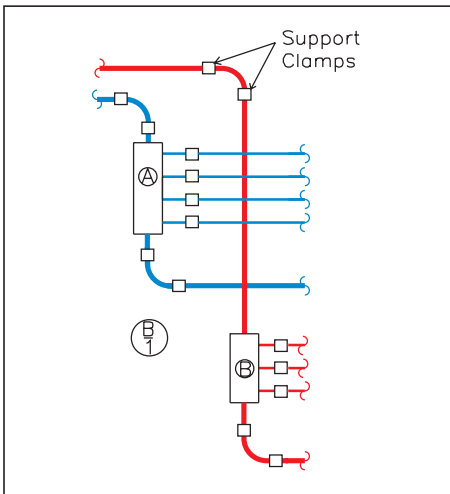
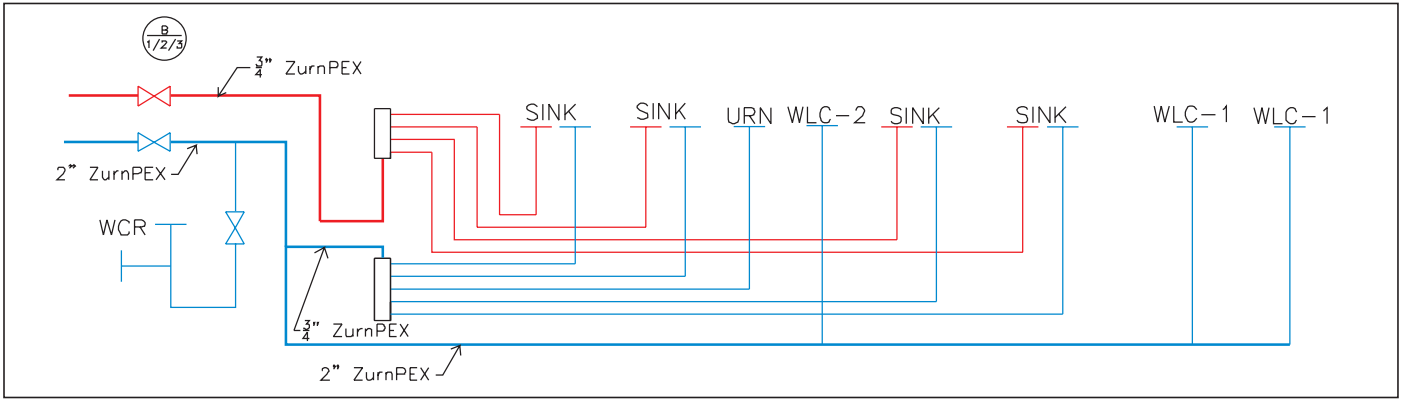

B/1		
A	QPM43-5	CR Manifold - 3/4" Inlet x (5) 1/2" Outlets
B	QPM43-4	CR Manifold - 3/4" Inlet x (4) 1/2" Outlets
A*	QCM43-6GX	Copper Manifold - 3/4" Inlet x (6) 1/2" Outlets
B*	QCM43-4GX	Copper Manifold - 3/4" Inlet x (4) 1/2" Outlets

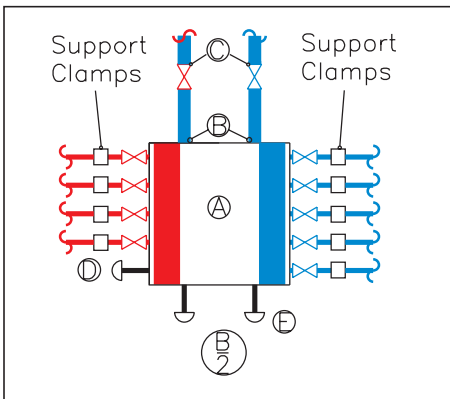

B/2		
A	QPPM10-3	Preassembled QickPort Manifold - 5 Hot, 5 Cold, with 1/2" CR Valves
B	QQPSFC45X	QickPort Inlet Connection - 1" Swivel x 3/4" Barb (CR)
C	QQBV44GX	3/4" x 3/4" Quarter-Turn Low-Lead Brass Ball Valves
D	QTC3FQP	QickPort 1/2" Outlet Cap
E	QTC5FBG	QickPort 1" Outlet Cap

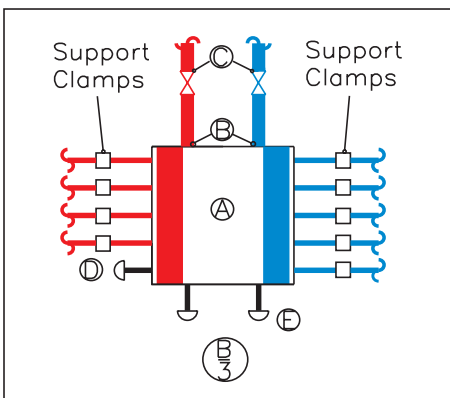

B/3		
A	QPPM10	Preassembled QickPort Manifold - 5 Hot, 5 Cold, No Valves
B	QQPSFC33X	1/2" CR Swivel Adaptors to Connect to QickPort Manifold Outlets
C	QQPSFC45X	QickPort Inlet Connection - 1" Swivel x 3/4" Barb (CR)
D	QQBV44GX	3/4" x 3/4" Quarter-Turn Low-Lead Brass Ball Valve
E	QTC3FQP	QickPort 1/2" Outlet Cap
F	QTC5FBG	QickPort 1" Outlet Cap



Hanging and Supporting Methods

Zurn PEX offers a basic assortment of holding and supporting accessories. There are numerous specialty manufacturers of such products. Within this section are a list of companies and some examples of their hanging and supporting equipment that is suitable for use with Zurn PEX systems. The pictures and devices are not all inclusive but serve as examples. The main points to consider when using supporting and hanging accessories with Zurn PEX tube are the following:

1. The hanger or support should not have any sharp or abrasive edges that could damage the tube. This can be accomplished by using plastic hangers or supports, or metal ones that are plastic coated or have rounded edges.
2. Hangers and supports shall be firm, but loose enough to allow tube to move back and forth as it expands and contracts.
3. Pipe straps should be used to hold pipe in position to prevent strain on fittings.

4. When suspended from the ceiling, tube must be supported every 32" maximum in a horizontal run.
5. If the tube is laying on a horizontal surface, it should be strapped every 6 feet.
6. Vertical runs should be supported at the floor of every floor and at the ceiling of every other floor and shall have a mid-story guide.
7. Protective sleeves or bushings must be used when penetrating a metal stud.

Manufacturers of supporting and hanging accessories (in no particular order):

- Cooper B-Line
- Holdrite®
- PHD Manufacturing

NSF Standards, Descriptions, and Markings

Zurn PEX utilizes NSF International as its third party listing agency for NSF and ASTM standard compliance for the majority of our products. NSF International is a well known and well respected listing agency. Zurn PEX listings can be found on the NSF International website at www.nsf.org.

NSF Standard 61 is the standard that establishes minimum health effects requirements for the chemical contaminants and impurities that are indirectly imparted to drinking water from products, components, and material used in drinking water systems. Zurn PEX systems intended for potable water meet the requirements of NSF 61.

NSF Standard 61 – Annex G is the annex to NSF Standard 61 that tests for the amount of lead in a product for conformance to California and Vermont low lead legislation. Zurn PEX systems intended for potable water meet the requirements for NSF 61 – Annex G.

NSF Standard 14 establishes physical, performance, and health effects requirements for plastic piping system components and related materials. Zurn PEX systems intended for potable water meet the requirements of NSF 14.

NSF Markings

- **NSF-pw** indicates compliance to NSF Standards 61 and 14.
- **cNSFus-pw** indicates compliance to NSF Standards 61 and 14 as well as compliance to Canadian and U.S. standards referenced in the respective national plumbing codes.
- **cNSFus-pw-G** indicates compliance to NSF Standards 61 and 14 including Annex G (low lead) as well as compliance to Canadian and U.S. standards referenced in the respective national plumbing codes.

ASTM Standards and Descriptions

PEX plumbing systems are frequently described in one or more different ASTM Standards. Zurn PEX has different PEX systems and components of each system may be described in different ASTM standards.

ASTM F 876 is the standard that specifies the material properties and the dimensions for PEX tube. This tubing is “copper tube size” meaning that the PEX tube has the same outside diameter as copper tube. All of the tube made to this standard has the same pressure-temperature ratings of 160 psi @ 73°F and 100 psi @ 180°F. For heating applications, the standard also has a pressure-temperature rating of 80 psi @ 200°F. Zurn PEX tube meets the requirements of ASTM F 876.

ASTM F 877 is the standard that specifies the performance requirements for a PEX system, tube and fittings together. It has requirements for Minimum Burst at 73°F and 180°F, Sustained Pressure Test (1000 hours) at 73°F and 180°F, Thermocycling at 100 psi and Excessive Temperature and Pressure for 30 days to simulate a water heater malfunction. The Zurn PEX systems meet the requirements of ASTM F 877.

ASTM F 1807 is the standard for brass or copper insert and crimp fittings. This standard specifies acceptable materials for these fitting and specifies the dimensions for the insert or barbed portion of the fittings. It also gives the dimensions and the material specifications for the copper crimp rings and the finished crimp dimensions. These fittings, when tested with PEX tube have to meet the performance requirements for PEX systems as required in ASTM F 877. Zurn PEX brass insert fittings and copper crimp rings meet the requirements of ASTM F 1807.

ASTM F 2159 is the standard for plastic insert and crimp fittings. This standard specifies the acceptable materials and dimensions for the fittings. It also has some test requirements for evaluating the quality of the molding process that was used to make the fittings. These fittings, when tested with PEX tube have to meet the performance requirements for PEX systems as required in ASTM F 877. Zurn PEX plastic insert fittings meet the requirements of ASTM F 2159.

Other ASTM Fitting Standards

ASTM F 1960 is the standard for “Cold Expansion Fittings” as sold by Wirsbo/Uponor. Zurn PEX tube can be used with these fittings so the standard number is included in the print string on our tube but the system is not covered by the Zurn PEX warranty.

ASTM F 2080 is the standard for “Cold Expansion Fittings with Metal Compression Sleeves” as sold by Rehau. Zurn PEX tube can be used with these fittings so the standard number is included in the print string on our tube but the system is not covered by the Zurn PEX warranty.

ASTM F 2098 is the standard for a “Stainless Steel Clamp” to be used in place of a copper crimp ring for brass or copper insert fittings meeting the requirements of F 1807 or plastic insert fittings meeting the requirements of ASTM F 2159. Zurn PEX does sell rings meeting the requirements of this standard and they are covered by a special, limited time warranty.

Detailed Description of the Test Requirements of ASTM F 877 for PEX Plumbing Systems

Burst Test at Room Temperature and 180°F

In this test, sample assemblies are subjected to a constantly increasing pressure until something fails. The minimum acceptable pressure depends on the size of the tube, but it is a minimum of 620 psi at room temperature and 275 psi at 180°F. The pressure is increased at a rate that will cause failure in about 1 minute. The significance of this test is that it demonstrates that the short term strength of the connection exceeds the strength of the tube.

Sustained Pressure Test at 180°F

In this test, sample assemblies are placed on a continuous pressure test while in an oven or water bath at 180°F. The pressure depends on the size of tube but it is a minimum of 190 psi. These samples are kept on test for 1000 hours (six weeks) and they must not leak or come apart.

The significance of this test is that it shows that at elevated temperature, the connection is capable of holding the same elevated test pressure that is required of the tube. Water pressure in homes is typically between 40 and 60 psi so this test pressure is at least 3 times the usual pressure in a plumbing system.

Thermocycle Test

In this test, sample assemblies are pressurized to 100 psi with nitrogen gas. They are then immersed in a hot water bath at 180°F and held there for a minimum of 2 minutes. After that the samples are moved to a cold water bath and held there for 2 minutes. This cycle is repeated 1000 times and the samples must not leak. This test demonstrates that the connection between the tube and fitting will remain leak free even as the temperature changes. This test is very harsh because nitrogen gas is a much smaller molecule than water and it will leak in situations where water would not.

Excessive Temperature and Pressure Test

In this test, sample assemblies are pressurized to 150 psi and kept in an oven at 210°F. The samples are maintained at this condition for 720 hours (30 days) and they must not leak or come apart. Most domestic water heaters have temperature/pressure relief valve that operate when the temperature exceeds 210°F or the pressure exceeds 150 psi. This test demonstrates that even at the extreme conditions of a water heater malfunction, the system is capable handling the pressure and temperature without leaking or coming apart.

Other Tests

In addition to the required ASTM tests, Zurn PEX has some in-house tests that our systems are expected to pass. Even though water hammer is typically not an issue with PEX plumbing, there are instances when PEX may be used in combination with a rigid piping material such as copper. In this instance, the PEX system may be subjected to pressure surges from water hammer in the rigid material. Zurn PEX systems are subjected to a minimum of 250,000 water hammer shocks with pressure surges up to 400 psi. They must withstand this without leaking or blowing apart.

250,000 water hammer shocks is equivalent to 25 shocks a day for 25 years. This test demonstrates that the connections do not fail or fatigue with repeated pressure shocks.

PEX tube, like all tubes, expands and contracts with changes in the air temperature and the water temperature in the tube. Because of this, connections are subjected to some flexing as the tube expands and contracts. Zurn PEX systems are subjected a flexing test for 250,000 cycles while being pressurized at 200 psi.

This test is intended to demonstrate that the connections do not leak even when there is flexing in the system caused by expansion and contraction of the tube.

A Summary of Zurn PEX Systems, Components, and Applicable ASTM Standards

Zurn PEX Tube

ASTM F 876, F 877

Zurn PEX Brass and Copper Insert Fittings

ASTM F 1807

Zurn PEX Plastic Insert Fittings



ASTM F 2159

Zurn PEX Quickclamp

ASTM F 877 as a system with Zurn PEX tube and Zurn PEX copper, brass, and plastic insert fittings.

Zurn PEX SSC

ASTM F 2098

 **WARNING:** Cancer and Reproductive Harm - www.P65Warnings.ca.gov
 **ADVERTENCIA:** Cáncer y daño reproductivo - www.P65Warnings.ca.gov
 **AVERTISSEMENT:** Cancer et effets néfastes sur la reproduction -
www.P65Warnings.ca.gov

ZURN PEX®, INC. 116 Maple Street, Commerce, TX 75428, 855-663-9876

In Canada: **ZURN INDUSTRIES LIMITED** 7900 Goreway Drive, Unit 10, Brampton, Ontario L6T 5W6, 905-405-8272

Form No. 370-060, 07/18



US 1.855.ONE.ZURN CANADA 1.877.892.5216 ZURN.COM