

Submittal Package

Viega ProPress® Systems



Project _____ **Date** _____

Engineer _____ **Contractor** _____

Submitted by _____

Approved by _____ **Date** _____ **Approved by** _____ **Date** _____

Table of Contents

Potable Water

Hydronic Heating

Chilled Water

Compressed Air

Nitrogen N₂

Argon

Low Pressure Steam

Fire Protection

Vacuum

Corgon

Oxygen O₂ (non-medical)

| | | |
|----------|-----------------------------------------|-----------|
| 1 | System Data Sheet _____ | 3 |
| | ProPress Fitting Systems _____ | 3 |
| 2 | Product Instructions _____ | 4 |
| | ProPress ½" to 2" Fittings _____ | 4 |
| | ProPress 2½" to 4" Fittings _____ | 5 |
| 3 | Engineering Specifications _____ | 6 |
| | ProPress Fitting System _____ | 6 |
| 4 | Dimensional Documents _____ | 10 |
| | ProPress Fittings _____ | 10 |
| 5 | Limited Warranty _____ | 31 |
| | Viega ProPress Fitting and Valves _____ | 31 |



This document is subject to updates. For the most current Viega technical literature please visit www.viega.us.



ProPress ½ to 2 formerly ProPress.
ProPress 2½ to 4 formerly ProPress XL.



Viega products are designed to be installed by licensed and trained plumbing and mechanical professionals who are familiar with Viega products and their installation. **Installation by non-professionals may void Viega LLC's warranty.**

1 System Data Sheet

ProPress Fitting Systems



Viega ProPress may only be pressed onto copper tube in accordance with ASTM B88 or B75. When pressing onto B88 copper tube, types K, L, and M may be used. Tempers O60 and O50, known as “soft copper”, are limited to nominal sizes ½" to 1¼". Temper H58, known as “hard copper”, may be used with nominal sizes ½" to 4".



When pressing onto B75 copper tube, additional considerations apply. See [Viega ProPress Copper Tube Compatibility Tech Data](#).

ProPress fittings are available in elbows, couplings, reducers, tees, reducing tees, threaded adapters, unions, caps, and flanges.

Components

- Alloy: Copper alloy - UNS C12200, Zero Lead silicon bronze alloy - C87710 (cast) or C87700 (machined)
- Peroxidically cured EPDM sealing element
- 420 stainless steel grip ring for 2½" to 4" fittings
- PBT separator ring for 2½" to 4" fittings

Operating Parameters

- Operating Pressure: 300 psi maximum
- Test Pressure: 600 psi maximum
- Operating Temperature: 0°F to 250°F

Listings and Certificates

- | | |
|-----------------|------------------------------------|
| ■ NSF/ANSI 61 | ■ ABS |
| ■ NSF/ANSI 372 | ■ CSA Low Lead Content |
| ■ IAPMO PS 117 | ■ ASME B16.51, B31.1, B31.3, B31.9 |
| ■ UL/ANSI 213 | ■ NFPA 13, 13D, 13R |
| ■ FM Class 1920 | |
| ■ ICC-ES IC1002 | |

Compliant With

- ASME B31
- ASTM B75
- ASTM B88
- IAPMO National Standard Plumbing Code (NSPC)
- IAPMO Uniform Mechanical Code (UMC)
- IAPMO Uniform Plumbing Code (UPC)
- ICC International Mechanical Code (IMC)
- ICC International Plumbing Code (IPC)
- ICC International Residential Code (IRC)
- NFPA 13, 13D, and 13R

Contact your local Viega representative for details on local approvals.

Approved Applications

- Hot and cold potable water
- Rainwater/gray water
- Fire sprinkler (175 psi maximum)
- Chilled water
- Hydronic heating (with glycol)
- Low pressure steam (15 psi maximum) with FKM sealing element swap
- Residential steam (5 psi maximum)
- Ethanol
- Compressed Air
- Non-medical gases
- Vacuum (29.2" Hg maximum @ 68°F)

ProPress fittings are approved for installations in both above and below ground applications. Per code, local inspector approval must be obtained prior to installation below ground.

Smart Connect® Technology

ProPress fittings are manufactured with Viega’s unique Smart Connect technology. A design of the fitting, Viega Smart Connect technology allows identification of an unpressed fitting during pressure testing.

2 Product Instructions

ProPress 1/2" to 2" Fittings

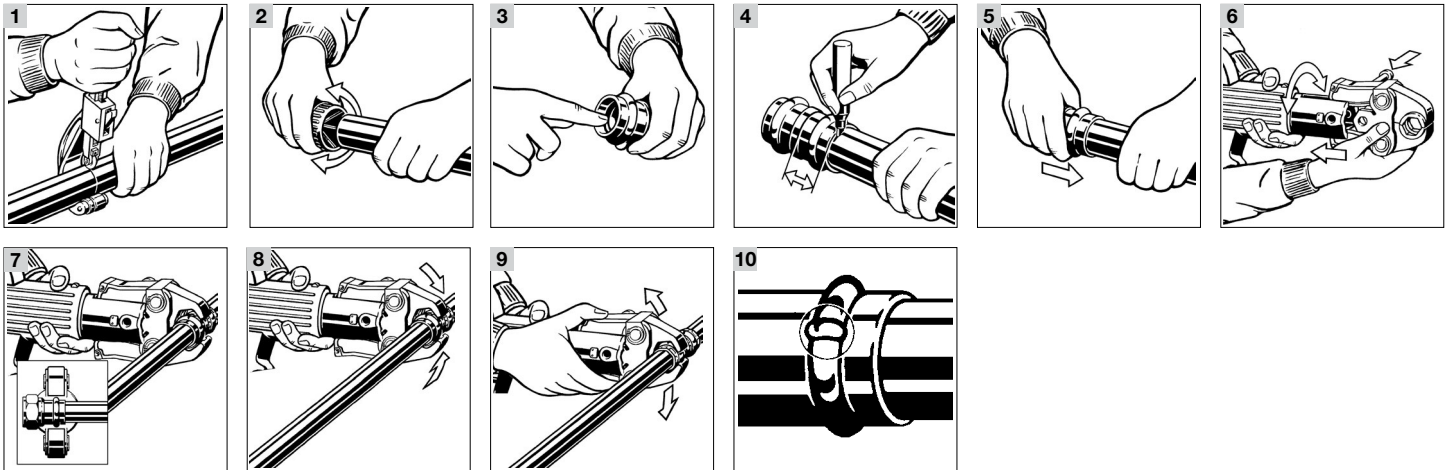

Viega ProPress 1/2" to 2" Fittings For Hard Copper Tubing in 1/2" to 2" and Soft Copper Tubing in 1/2" to 1 1/4".

- 1 Cut the tube square using a displacement-type cutter or fine toothed saw.
Note: Cut tubing a minimum of 4" away from the contact area of the vise to prevent possible damage to the tubing in the press area.
- 2 Deburr inside and outside of the tube to the proper insertion depths to prevent cutting sealing element.
- 3 Check the sealing element for correct fit. Do not use oils or lubricants. Use only Viega sealing elements.

i For applications requiring Viega ProPress with FKM or HNBR sealing elements, remove the factory-installed EPDM sealing element and replace with an FKM or HNBR sealing element. See [Changing Sealing Elements Product Instructions](#).

- 4 Mark the proper insertion depth as indicated by the ProPress Insertion Depth Chart. Improper insertion depth may result in an improper seal.

| ProPress Insertion Depth Chart | |
|--------------------------------|----------------------|
| Tube Size (in) | Insertion Depth (in) |
| 1/2 | 3/4 |
| 3/4 | 7/8 |
| 1 | 7/8 |
| 1 1/4 | 1 |
| 1 1/2 | 1 1/16 |
| 2 | 1 9/16 |

i Copper tubing must be free of surface imperfections, including metal stamped print lines, before a ProPress fitting is installed.

- 5 While turning slightly, slide press fitting onto tubing to the marked depth. End of tubing must contact stop.
- 6 Insert appropriate Viega ProPress jaw into the press tool and push in, holding pin until it locks in place.
- 7 Open the jaw and place at right angle on the fitting. Visually check insertion depth using mark on tubing.

Warning!
Keep extremities and foreign objects away from press tool during pressing operation to prevent injury or incomplete press.

- 8 Hold trigger on press tool until press jaws have fully engaged the fitting. Jaws will automatically release after a full press is made.
- 9 After pressing, open the jaw and remove the press tool.
- 10 Pressure testing with Smart Connect®: Unpressed connections are located by pressurizing the system with air or water. When testing with water the proper pressure range is 15 psi to 85 psi. When testing with compressed air the proper pressure range is 1/2 psi to 45 psi maximum. If testing with compressed air, use an approved leak-detect solution. Following a successful pressure test, the system may be pressure tested up to 200 psi with air or up to 600 psi with water.

i Testing for unpressed connections using Smart Connect is not a replacement for pressure testing requirements of local codes and standards.

Product Instructions

ProPress 2½" to 4" Fittings

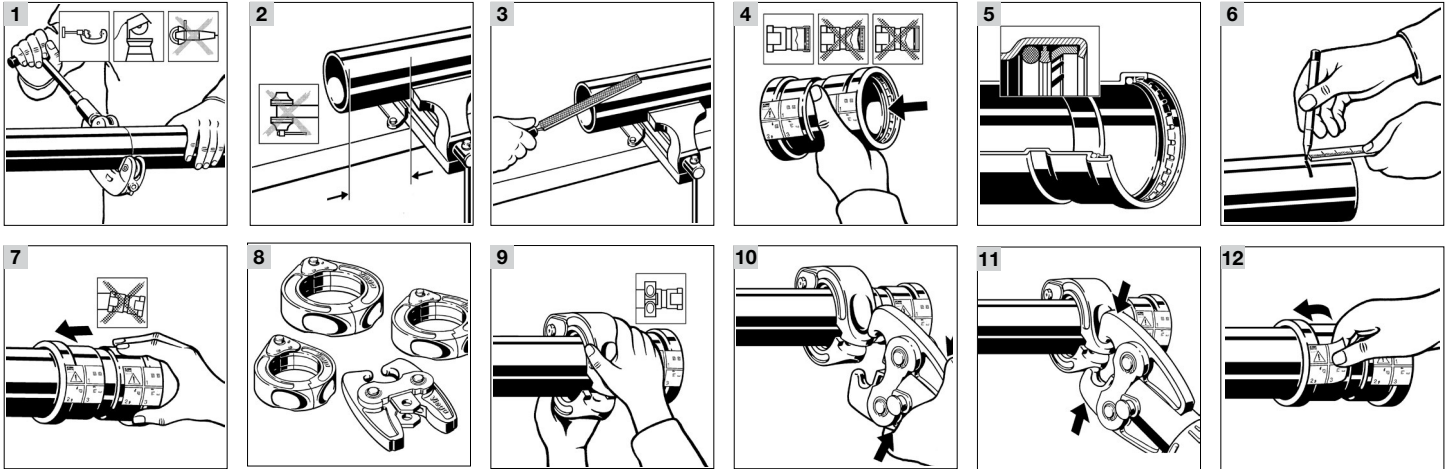

Viega ProPress 2½" to 4" Fittings For Hard Copper Tubing.

- 1 Cut copper tubing at right angles using displacement-type cutter or fine-toothed steel saw.
- 2 Keep end of tubing a minimum of 4" away from the contact area of the vise to prevent possible damage to the tubing in the press area.
- 3 Remove burr from inside and outside of tubing to prevent cutting sealing element.
- 4 Check seal and grip ring for correct fit. Ensure sealing element is free of cuts and damage. Do not use oils or lubricants.

i For applications requiring Viega ProPress with FKM or HNBR sealing elements, remove the factory-installed EPDM sealing element and replace with an FKM or HNBR sealing element. See [Changing Sealing Elements Product Instructions](#).

- 5 Illustration demonstrates proper fit of grip ring, separation ring and sealing element.

- 6 Mark proper insertion depth as indicated by the ProPress Insertion Depth Chart. Improper insertion depth may result in an improper seal.

| ProPress Insertion Depth Chart | |
|--------------------------------|----------------------|
| Tube Size (in) | Insertion Depth (in) |
| 2½ | 1 11/16 |
| 3 | 1 15/16 |
| 4 | 2 3/8 |

- 7 While turning slightly, slide press fitting onto tubing to the marked depth. End of tubing must contact stop.
- 8 ProPress 2½" to 4" fitting connections must be performed with rings that are compatible with fittings. Do not mix actuators and rings from different manufacturers. Use of ProPress XL rings and/or actuator (for bronze fittings) will result in an improper connection. See Operator's Manual for proper tool instructions.

CAUTION! Use only rings that are compatible with ProPress 2½" to 4" fittings.

- Use of incompatible rings will result in an improper connection.
- Do not mix actuators and rings from different manufacturers.
- Do not use rings intended for 2½" to 4" Bronze fittings.

- 9 Open XL-C ring and place at right angles on the fitting. XL-C ring must be engaged on the fitting bead. Check insertion depth.
- 10 With V2 actuator inserted into the tool, open the V2 actuator as shown and connect V2 actuator to the XL-C ring.
- 11 Place V2 actuator onto XL-C ring and start pressing process. Hold the trigger until the actuator has engaged the XL-C ring. Keep extremities and foreign objects away from XL-C ring and V2 actuator during pressing operation to prevent injury or incomplete press.
- 12 Release V2 actuator from XL-C ring and then remove the XL-C ring from the fitting on completion of press. Remove tag from fitting, indicating press has been performed.

Pressure Testing with Smart Connect®

Unpressed connections are located by pressurizing the system with air or water. When testing with water the proper pressure range is 15 psi to 85 psi. When testing with compressed air the proper pressure range is ½ psi to 45 psi maximum. If testing with compressed air, use an approved leak-detect solution. Following a successful pressure test, the system may be pressure tested up to 200 psi with air or up to 600 psi with water.

i Testing for unpressed connections using Smart Connect is not a replacement for pressure testing requirements of local codes and standards.

3 Engineering Specifications

ProPress Fitting System

Part 1: General

1.1 Summary

Copper tubing and fitting system for hot and cold water distribution systems, sprinkler and standpipe systems, and hydronic piping systems.

1.2 Definitions

ASME: American Society of Mechanical Engineers

ASTM: American Society for Testing and Materials

AWWA: American Water Works Association

EPDM: Ethylene Propylene Diene Monomer

FM: Factory Mutual

IAPMO: International Association of Plumbing & Mechanical Officials

ICC: International Code Council

MSS: Manufacturers Standardization Society

NFPA: National Fire Protection Association

NSF: National Sanitation Foundation

UL: Underwriters Laboratory

1.3 References

ASME A13.1: Scheme for the Identification of Piping Systems

ASME B1.20.1: Pipe Threads, General Purpose (inch)

ASME B16.18: Cast Copper Alloy Solder Joint Pressure Fittings

ASME B16.22: Wrought Copper and Copper Alloy Solder-Joint Pressure Fittings

ASME B16.26: Cast Copper Alloy Fittings for Flared Copper Tube

ASME B16.51: Copper and Copper Alloy Press-Connect Pressure Fittings

ASME B31.9: Building Services Piping

ASTM B75: Standard Specification for Seamless Copper Tube

ASTM B88: Standard Specification for Seamless Copper Water Tube

ASTM B813: Standard Specification for Liquid and Paste Fluxes for Soldering Applications of Copper and Copper Alloy Tube

ASTM B828: Standard Practice for Making Capillary Joints by Soldering of Copper and Copper Alloy Tube and Fittings

AWWA C651: Standard for Disinfecting Water Mains

IAPMO: Uniform Mechanical Code

IAPMO: Uniform Plumbing Code

IAPMO PS-117: Press and Nail Connections

ICC: International Plumbing Code

ICC: International Mechanical Code

MSS-SP-58 Pipe Hangers and Supports Materials, Design and Manufacturer

NFPA 13 Standard for the Installation of Sprinkler Systems

NFPA 13D Standard for the Installation of Sprinkler Systems in One/Two Family Dwellings and Mobile Homes

NFPA 13R Standard for the Installation of Sprinkler Systems for Residential Occupancies up to and including Four Stories in Height

NFPA 14 Standard for the Installation of Standpipe and Hose Systems

NFPA 54 National Fuel Gas Code

NSF/ANSI 61 Drinking Water System Components - Health Effects

NSF/ANSI 372 Drinking Water System Components - Lead Content

1.4 Quality Assurance

- A. Installer shall be a qualified installer, licensed within the jurisdiction, and familiar with the installation of ProPress copper press joint systems.
- B. ProPress copper press fittings shall be installed using the proper tool, actuator, jaws and rings as instructed by the press fitting manufacturer.
- C. The installation of copper tubing for hot and cold water distribution systems shall conform to the requirements of the ICC International Plumbing Code or IAPMO Uniform Plumbing Code.
- D. The installation of copper tubing in sprinkler or standpipe systems shall conform to NFPA 13, 13D, 13R, and 14.
- E. The installation of copper tubing in hydronic systems shall conform to the requirements of the ICC International Mechanical Code or the IAPMO Uniform Mechanical Code.
- F. ASME Compliance: ASME B31.9 for building services piping valves.

1.5 Delivery, Storage, and Handling

- A. Copper tubing shall be shipped to the job site on truck or in such a manner to protect the tubing. The tubing and fittings shall not be roughly handled during shipment. Tubing and fittings shall be unloaded with reasonable care.
- B. Protect the stored product from moisture and dirt. Elevate above grade. When stored inside, do not exceed the structural capacity of the floor.
- C. Protect fittings and piping specialties from moisture and dirt.

1.6 Project Conditions

Verify length of tubing required by field measurements.

1.7 Warranty

- A. The tubing and fittings manufacturer shall warrant that the tubing and fittings are free from defects and conform to the designated standard. The warranty shall only be applicable to tubing and fittings installed in accordance with the manufacturer's installation instructions.
- B. The manufacturer of the fittings shall not be responsible for the improper use, handling, or installation of the product.

Part 2: Products

2.1 Manufactures

Viega LLC
 585 Interlocken Blvd.
 Broomfield CO, 80021
 Phone: (800) 976-9819
 www.viega.us

2.2 Material

- A. Tubing standard: copper tubing shall conform to ASTM B75 within Viega specifications or ASTM B88.



When pressing onto B75 copper tube, additional considerations apply. See [Viega ProPress Copper Tube Compatibility Tech Data](#).

- B. Fitting standard: copper fittings shall conform to ASME B16.18, ASME B16.22, or ASME B16.26.

- C. Press fitting: copper and copper alloy press fittings shall conform to material requirements of ASME B16.18 or ASME B16.22 and performance criteria of ASME B16.51 and IAPMO PS 117 (IAPMO PS 117 is not for B75). Sealing elements for press fittings shall be EPDM. Sealing elements shall be factory installed or an alternative supplied by fitting manufacturer. Press ends shall have Smart Connect® technology. In ProPress ½" to 4" dimensions, Viega's unique Smart Connect technology allows identification of an unpressed fitting during pressure testing. The function of this feature is to provide the installer quick and easy identification of connections which have not been pressed prior to putting the system into operation.
- D. Threaded fittings: pipe threads shall conform to ASME B1.20.1.
- E. Hanger standard: hangers and supports shall conform to MSS-SP-58.

2.3 Source Quality Control

- A. All fittings in contact with drinking water shall be listed by a third party agency to NSF/ANSI 61 & 372.
- B. All fittings used in fire sprinkler applications shall be UL listed.
- C. All fittings used in fire sprinkler applications shall be FM approved.

Part 3: Execution

3.1 Examination

- A. The installing contractor shall examine the copper tubing and fittings for defects, sand holes, and cracks. There shall be no defects of the tubing or fittings. Any damaged tubing or fittings shall be rejected.
- B. The installing contractor shall insure that sealing elements are properly in place and free from damage. For sizes 2½" to 4", installer should insure that the stainless steel grip ring is in place.

3.2 Preparation

- A. Copper tubing shall be cut with a wheeled tubing cutter or approved copper tubing cutting tool. The tubing shall be cut square to permit proper joining with the fittings.
- B. Remove scale, slag, dirt, and debris from inside and outside of tubing and fittings before assembly. The tubing end shall be wiped clean and dry. The burrs on the tubing shall be reamed with a deburring or reaming tool.

3.3 Installation General Locations

Plans indicate general location and arrangement of piping systems. Identified locations and arrangements are used to size tubing and calculate friction loss, expansion, pump sizing, and other design considerations. Install piping as indicated, except where deviations to layout are approved on coordination drawings.

3.4 Installation

- A. Pressure rating: install components having a pressure rating equal to or greater than the system operating pressure.
- B. Install piping free of sags, bends, and kinks.
- C. Change in direction: install fittings for changes in direction and branch connections. Where approved, changes in direction may also be made by bending of types K and L tube or those with equivalent wall thicknesses.
- D. Solder joints: solder joints shall be made in accordance with ASTM B 828. The temperature of the joint during soldering shall not be raised above the maximum temperature limitation of the flux.
- E. Threaded joints: threaded joints shall have pipe joint compound or teflon tape applied to the male threads only. Tighten joint with a wrench and backup wrench as required.
- F. Flared joints: flared copper tube joints shall be made by the appropriate use of cast copper alloy fittings. Flared ends of copper tube shall be of the 45-degree flare type and shall only be made with a flaring tool designed specifically for that purpose.
- G. Press connections: copper and copper alloy press connections shall be made in accordance with the manufacturer's installation instructions. The tubing shall be fully inserted into the fitting and the tubing marked at the shoulder of the fitting. The fitting alignment shall be checked against the mark on the tubing to assure the tubing is fully engaged (inserted) in the fitting. The joints shall be pressed using the tool(s) approved by the manufacturer.

- H. Pipe protection: provide protection against abrasion where copper tubing is in contact with other building members by wrapping with an approved tape, pipe insulation, or otherwise suitable method of isolation.
- I. Penetration protection: provide allowance for thermal expansion and contraction of copper tubing passing through a wall, floor, ceiling, or partition by wrapping with an approved tape or pipe insulation or by installing through an appropriately sized sleeve. Penetrations for fire resistant rated assemblies shall maintain the rating of the assembly.
- J. Backfill material: backfill material shall not include any ashes, cinders, refuse, stones, boulders, or other materials which can damage or break the tubing or promote corrosive action in any trench or excavation in which tubing is installed.
- K. Horizontal support: install hangers for horizontal piping in accordance with MSS-SP-58.
- L. Vertical support: vertical copper tubing shall be supported at each floor.
- M. Galvanic corrosion: hangers and supports shall be either copper or vinyl coated to prevent galvanic corrosion between the tubing and the supporting member.
- N. Seismic restraint: in seismic areas, copper tubing shall be installed to withstand all seismic forces.
- O. Piping identification: copper tubing systems shall be identified in accordance with the requirements of ASME A13.1.

3.5 Field Quality Control

- A. Water testing: the copper tubing system shall be water tested for joint tightness. The piping system shall be filled with water. The system shall be pressurized to the maximum pressure and length of time required by the code or standard. The system shall have no leaks at the rated pressure.
- B. Air testing: the copper tubing system shall be air tested for joint tightness. The piping system shall be pressurized with air to the maximum pressure of the system or to the code or standard required minimum for the required length of time. The system shall have no leaks at the rated pressure.

3.6 Cleaning (Potable Water Systems)

- A. Disinfection: the copper hot and cold water distribution system shall be disinfected prior to being placed in service. The system shall be disinfected in accordance with AWWA C651 or the following requirements:
 1. The piping system shall be flushed with potable water until discolored water does not appear at any of the outlets.
 2. The system shall be filled with a water chlorine solution containing at least 50 parts per million of chlorine. The system shall be valved off and allowed to stand for 24 hours or the system shall be filled with a water chlorine solution containing at least 200 parts per million of chlorine. The system shall be valved off and allowed to stand for 3 hours.
 3. Following the standing time, the system shall be flushed with water until the chlorine is purged from the system.

4 Dimensional Documents

ProPress Fittings

Viega ProPress 90° Elbow Copper P x P - Model 2916

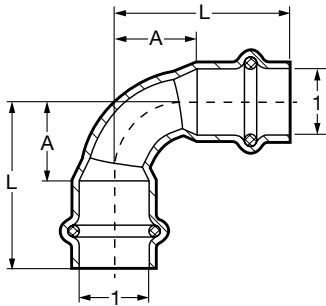

| Part No. | Size (in) | A (in) | L (in) |
|----------|---------------|--------|--------|
| | 1 1 | | |
| 77317 | 1/2 x 1/2 | 0.75 | 1.50 |
| 77022 | 3/4 x 3/4 | 0.76 | 1.67 |
| 77027 | 1 x 1 | 1.28 | 2.19 |
| 77032 | 1 1/4 x 1 1/4 | 1.28 | 2.31 |
| 77037 | 1 1/2 x 1 1/2 | 1.29 | 2.72 |
| 77042 | 2 x 2 | 2.16 | 3.74 |

Viega ProPress 90° Elbow P x P - Model 0916XL

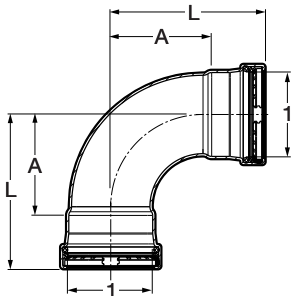

| Part No. | Size (in) | A (in) | L (in) |
|----------|---------------|--------|--------|
| | 1 1 | | |
| 20623 | 2 1/2 x 2 1/2 | 3.19 | 4.88 |
| 20628 | 3 x 3 | 3.76 | 5.73 |
| 20633 | 4 x 4 | 4.90 | 7.26 |

Viega ProPress 90° Street Elbow Copper P x FTG - Model 2916.1

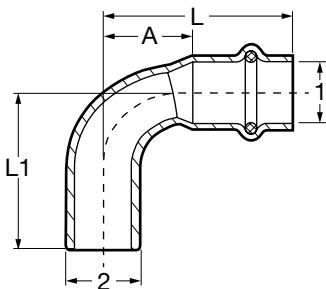

| Part No. | Size (in) | A (in) | L (in) | L1 (in) |
|----------|---------------|--------|--------|---------|
| | 1 2 | | | |
| 77347 | 1/2 x 1/2 | 0.75 | 1.50 | 1.54 |
| 77052 | 3/4 x 3/4 | 0.76 | 1.67 | 1.83 |
| 77057 | 1 x 1 | 1.28 | 2.19 | 2.27 |
| 77062 | 1 1/4 x 1 1/4 | 1.28 | 2.31 | 2.48 |
| 77067 | 1 1/2 x 1 1/2 | 1.29 | 2.72 | 2.80 |
| 77072 | 2 x 2 | 2.16 | 3.74 | 3.78 |

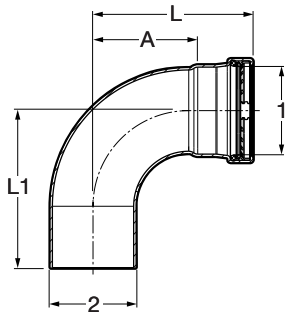
Viega ProPress 90° Street Elbow P x FTG - Model 0916.1XL

| Part No. | Size (in) | | A (in) | L (in) | L1 (in) |
|----------|-----------|----|--------|--------|---------|
| | 1 | 2 | | | |
| 20638 | 2½ | 2½ | 3.19 | 4.88 | 4.80 |
| 20643 | 3 | 3 | 3.76 | 5.73 | 5.63 |
| 20648 | 4 | 4 | 4.90 | 7.26 | 7.13 |

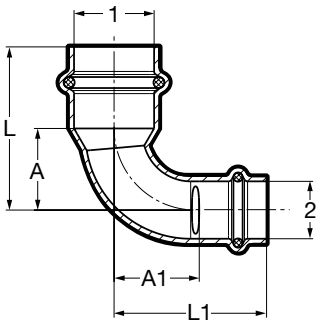
Viega ProPress 90° Reducing Elbow Copper P x P - Model 2916.3

| Part No. | Size (in) | | A (in) | A1 (in) | L (in) | L1 (in) |
|----------|-----------|---|--------|---------|--------|---------|
| | 1 | 2 | | | | |
| 77325 | ¾ | ½ | 0.91 | 0.94 | 1.81 | 1.69 |
| 77330 | 1 | ¾ | 1.20 | 1.30 | 2.11 | 2.21 |

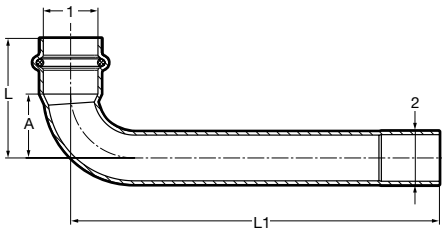
Viega ProPress 90° Extended Street Elbow Copper P x FTG - Model 2947

| Part No. | Size (in) | | A (in) | L (in) | L1 (in) |
|----------|-----------|---|--------|--------|---------|
| | 1 | 2 | | | |
| 77353 | ¾ | ¾ | 1.02 | 1.93 | 5.98 |

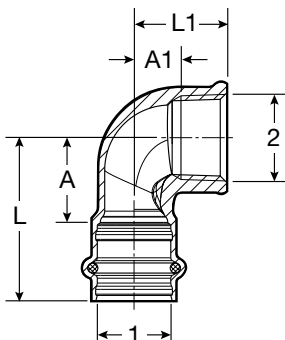
Viega ProPress 90° Elbow Zero Lead Bronze P x FPT - Model 2914.2ZL

| Part No. | Size (in) | | A (in) | A1 (in) | L (in) | L1 (in) |
|----------|-----------|--------|--------|---------|--------|---------|
| | 1 | 2 | | | | |
| 79520 | ½ | ¾ FPT | 0.94 | 0.42 | 1.77 | 0.83 |
| 79525 | ½ | ½ FPT | 0.94 | 0.57 | 1.77 | 1.10 |
| 79530 | ½ | ¾ FPT | 1.06 | 0.51 | 1.89 | 1.06 |
| 79535 | ¾ | ½ FPT | 1.06 | 0.65 | 1.97 | 1.18 |
| 79540 | ¾ | ¾ FPT | 1.06 | 0.57 | 1.97 | 1.12 |
| 79545 | 1 | ½ FPT | 1.06 | 0.72 | 1.97 | 1.26 |
| 79550 | 1 | 1 FPT | 1.34 | 0.76 | 2.24 | 1.42 |
| 79560 | 1¼ | 1¼ FPT | 1.54 | 0.89 | 2.56 | 1.57 |
| 79565 | 1½ | 1½ FPT | 1.69 | 1.05 | 3.11 | 1.73 |
| 79570 | 2 | 2 FPT | 2.17 | 1.35 | 3.74 | 2.05 |

Viega ProPress Vent Elbow Zero Lead Bronze P x P x FPT - Model 2917.3ZL

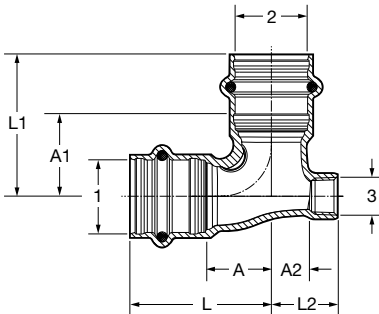

| Part No. | Size (in) | | | A (in) | A1 (in) | A2 (in) | L (in) | L1 (in) | L2 (in) |
|----------|-----------|-----|-----|--------|---------|---------|--------|---------|---------|
| | 1 | 2 | 3 | | | | | | |
| 79635 | 1/2 | 1/2 | 1/8 | 0.67 | 0.67 | 0.44 | 1.50 | 1.50 | 0.71 |
| 79640 | 3/4 | 3/4 | 1/8 | 0.83 | 0.83 | 0.54 | 1.73 | 1.73 | 0.81 |

Viega ProPress 90° Hi Ear Elbow Zero Lead Bronze P x FPT - Model 2925.2ZL

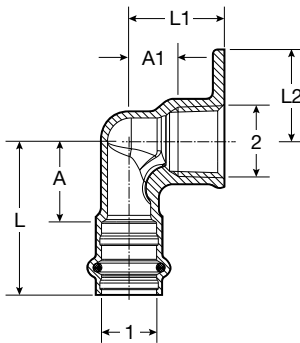

| Part No. | Size (in) | | A (in) | A1 (in) | L (in) | L1 (in) | L2 (in) |
|----------|-----------|-----|--------|---------|--------|---------|---------|
| | 1 | 2 | | | | | |
| 79205 | 1/2 | 1/2 | 0.94 | 0.57 | 1.77 | 1.10 | 1.07 |

Viega ProPress 90° Drop Ear Elbow Zero Lead Bronze P X FPT - Model 2925.5ZL

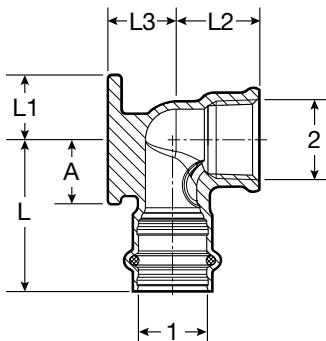

| Part No. | Size (in) | | A (in) | L (in) | L1 (in) | L2 (in) | L3 (in) |
|----------|-----------|-----|--------|--------|---------|---------|---------|
| | 1 | 2 | | | | | |
| 79185 | 1/2 | 3/8 | 0.94 | 1.77 | 0.74 | 0.83 | 0.67 |
| 79190 | 1/2 | 1/2 | 0.94 | 1.77 | 0.74 | 1.10 | 0.67 |
| 79195 | 3/4 | 3/4 | 1.06 | 1.97 | 0.83 | 1.12 | 0.83 |

Viega ProPress Double Drop Elbow Zero Lead Bronze P x P x FPT - Model 2928.7ZL

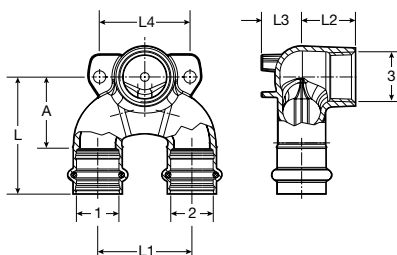

| Part No. | Size (in) | | | A (in) | L (in) | L1 (in) | L2 (in) | L3 (in) | L4 (in) |
|----------|-----------|-----|-----|--------|--------|---------|---------|---------|---------|
| | 1 | 2 | 3 | | | | | | |
| 78800 | 1/2 | 1/2 | 1/2 | 1.34 | 2.17 | 1.97 | 1.10 | 0.67 | 1.57 |
| 78802 | 3/4 | 3/4 | 1/2 | 1.54 | 2.44 | 1.97 | 1.10 | 0.83 | 2.05 |
| 78801 | 3/4 | 3/4 | 3/4 | 1.54 | 2.44 | 1.97 | 1.12 | 0.83 | 1.89 |
| 78803 | 1 | 1 | 1/2 | 1.77 | 2.68 | 2.36 | 1.10 | 0.87 | 2.52 |

Viega ProPress 45° Elbow Copper P x P - Model 2926

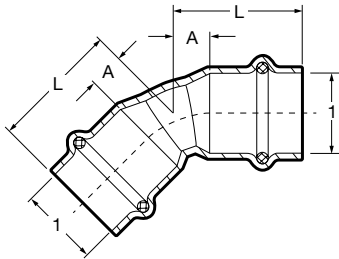

| Part No. | Size (in) | A (in) | L (in) |
|----------|---------------|--------|--------|
| | 1 1 | | |
| 77607 | 1/2 x 1/2 | 0.30 | 1.04 |
| 77023 | 3/4 x 3/4 | 0.36 | 1.26 |
| 77028 | 1 x 1 | 0.47 | 1.38 |
| 77033 | 1 1/4 x 1 1/4 | 0.58 | 1.61 |
| 77038 | 1 1/2 x 1 1/2 | 0.65 | 2.08 |
| 77043 | 2 x 2 | 0.86 | 2.44 |

Viega ProPress 45° P x P - Model 0926XL

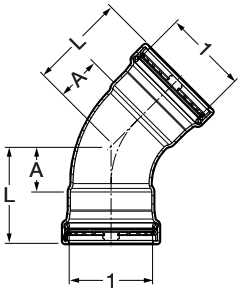

| Part No. | Size (in) | A (in) | L (in) |
|----------|---------------|--------|--------|
| | 1 1 | | |
| 20653 | 2 1/2 x 2 1/2 | 1.48 | 3.18 |
| 20658 | 3 x 3 | 1.73 | 3.70 |
| 20663 | 4 x 4 | 1.96 | 4.63 |

Viega ProPress 45° Street Elbow Copper P x FTG - Model 2926.1

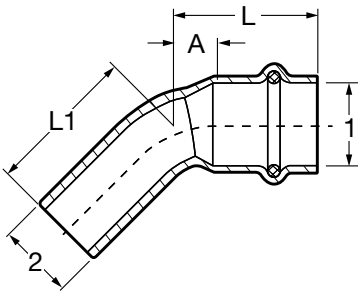

| Part No. | Size (in) | A (in) | L (in) | L1 (in) |
|----------|---------------|--------|--------|---------|
| | 1 2 | | | |
| 77637 | 1/2 x 1/2 | 0.31 | 1.06 | 1.10 |
| 77053 | 3/4 x 3/4 | 0.36 | 1.26 | 1.30 |
| 77058 | 1 x 1 | 0.47 | 1.38 | 1.49 |
| 77063 | 1 1/4 x 1 1/4 | 0.58 | 1.61 | 1.67 |
| 77068 | 1 1/2 x 1 1/2 | 0.65 | 2.08 | 2.04 |
| 77073 | 2 x 2 | 0.86 | 2.44 | 2.54 |

Viega ProPress 45° Street Elbow P x FTG - Model 0926.1XL

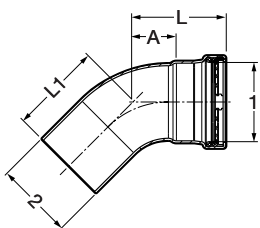

| Part No. | Size (in) | A (in) | L (in) | L1 (in) |
|----------|---------------|--------|--------|---------|
| | 1 2 | | | |
| 20668 | 2 1/2 x 2 1/2 | 1.48 | 3.18 | 3.10 |
| 20673 | 3 x 3 | 1.73 | 3.70 | 3.60 |
| 20678 | 4 x 4 | 2.23 | 4.59 | 4.45 |

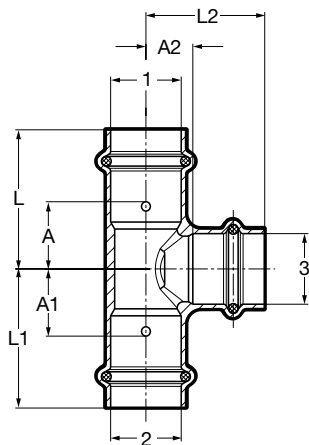
Viega ProPress Tee Copper P x P x P - Model 2918

| Part No. | Size (in) | A (in) | A1 (in) | A2 (in) | L (in) | L1 (in) | L2 (in) |
|----------|-----------------------|--------|---------|---------|--------|---------|---------|
| | 1 2 3 | | | | | | |
| 77377 | 1/2 x 1/2 x 1/2 | 0.75 | 0.75 | 0.50 | 1.50 | 1.50 | 1.25 |
| 77382 | 1/2 x 1/2 x 3/4 | 0.91 | 0.91 | 0.59 | 1.65 | 1.65 | 1.50 |
| 15493 | 1/2 x 1/2 x 1 | 1.10 | 1.10 | 0.55 | 1.85 | 1.85 | 1.46 |
| 77387 | 3/4 x 3/4 x 3/4 | 0.85 | 0.85 | 0.59 | 1.75 | 1.75 | 1.50 |
| 77392 | 3/4 x 1/2 x 1/2 | 0.69 | 0.98 | 0.63 | 1.59 | 1.73 | 1.38 |
| 77397 | 3/4 x 1/2 x 3/4 | 0.85 | 1.14 | 0.59 | 1.75 | 1.89 | 1.50 |
| 77402 | 3/4 x 3/4 x 1/2 | 0.69 | 0.69 | 0.63 | 1.59 | 1.59 | 1.38 |
| 77407 | 3/4 x 3/4 x 1 | 0.97 | 0.97 | 0.63 | 1.87 | 1.87 | 1.54 |
| 77412 | 1 x 1 x 1 | 0.97 | 0.97 | 0.79 | 1.87 | 1.87 | 1.69 |
| 22263 | 1 x 1/2 x 3/4 | 0.85 | 1.24 | 0.75 | 1.76 | 1.99 | 1.66 |
| 94767 | 1 x 1/2 x 1 | 0.97 | 1.52 | 0.79 | 1.87 | 2.26 | 1.69 |
| 77417 | 1 x 3/4 x 1/2 | 0.69 | 0.89 | 0.79 | 1.59 | 1.79 | 1.54 |
| 77422 | 1 x 3/4 x 3/4 | 0.85 | 1.04 | 0.75 | 1.75 | 1.95 | 1.65 |
| 77427 | 1 x 3/4 x 1 | 0.97 | 1.18 | 0.78 | 1.87 | 2.07 | 1.69 |
| 77432 | 1 x 1 x 1/2 | 0.69 | 0.69 | 0.79 | 1.59 | 1.59 | 1.54 |
| 77437 | 1 x 1 x 3/4 | 0.85 | 0.85 | 0.75 | 1.75 | 1.75 | 1.65 |
| 15488 | 1 x 1 x 1 1/4 | 1.16 | 1.16 | 0.84 | 2.07 | 2.07 | 1.87 |
| 77442 | 1 1/4 x 1 1/4 x 1 1/4 | 1.02 | 1.02 | 0.86 | 2.05 | 2.05 | 1.89 |
| 22253 | 1 1/4 x 1/2 x 1 1/4 | 1.02 | 1.77 | 0.87 | 2.05 | 2.52 | 1.89 |
| 22243 | 1 1/4 x 3/4 x 1/2 | 0.64 | 1.13 | 0.93 | 1.68 | 2.03 | 1.68 |
| 22258 | 1 1/4 x 3/4 x 3/4 | 0.76 | 1.30 | 0.87 | 1.80 | 2.21 | 1.78 |
| 22268 | 1 1/4 x 3/4 x 1 | 0.88 | 1.40 | 0.91 | 1.91 | 2.31 | 1.82 |
| 22248 | 1 1/4 x 3/4 x 1 1/4 | 1.02 | 1.54 | 0.86 | 2.05 | 2.45 | 1.89 |
| 22238 | 1 1/4 x 1 x 1/2 | 0.64 | 0.91 | 0.93 | 1.68 | 1.82 | 1.68 |
| 94762 | 1 1/4 x 1 x 3/4 | 0.76 | 1.14 | 0.87 | 1.79 | 2.05 | 1.77 |
| 14568 | 1 1/4 x 1 x 1 | 0.88 | 1.28 | 0.91 | 1.91 | 2.19 | 1.81 |
| 94757 | 1 1/4 x 1 1/4 x 1/2 | 0.65 | 0.65 | 0.93 | 1.67 | 1.67 | 1.67 |
| 77452 | 1 1/4 x 1 1/4 x 3/4 | 0.77 | 0.77 | 0.89 | 1.79 | 1.79 | 1.77 |
| 77447 | 1 1/4 x 1 1/4 x 1 | 0.88 | 0.88 | 0.90 | 1.91 | 1.91 | 1.81 |
| 77457 | 1 1/2 x 1 1/2 x 1 1/2 | 1.13 | 1.13 | 1.13 | 2.56 | 2.56 | 2.56 |
| 79660 | 1 1/2 x 1 x 3/4 | 0.67 | 1.39 | 1.16 | 2.17 | 2.44 | 2.05 |
| 15458 | 1 1/2 x 1 x 1 | 0.74 | 1.54 | 1.06 | 2.17 | 2.44 | 1.97 |
| 15463 | 1 1/2 x 1 x 1 1/2 | 1.13 | 1.83 | 1.13 | 2.56 | 2.74 | 2.56 |
| 22233 | 1 1/2 x 1 1/4 x 3/4 | 0.67 | 1.08 | 1.15 | 2.09 | 2.11 | 2.05 |
| 15453 | 1 1/2 x 1 1/4 x 1 | 0.74 | 1.29 | 1.18 | 2.17 | 2.32 | 2.09 |
| 15483 | 1 1/2 x 1 1/4 x 1 1/4 | 0.86 | 1.33 | 1.13 | 2.28 | 2.36 | 2.17 |
| 15448 | 1 1/2 x 1 1/2 x 1/2 | 0.47 | 0.47 | 1.10 | 1.89 | 1.89 | 1.85 |
| 77462 | 1 1/2 x 1 1/2 x 3/4 | 0.66 | 0.66 | 1.14 | 2.09 | 2.09 | 2.05 |
| 77467 | 1 1/2 x 1 1/2 x 1 | 0.74 | 0.74 | 1.18 | 2.17 | 2.17 | 2.09 |
| 77472 | 1 1/2 x 1 1/2 x 1 1/4 | 0.86 | 0.86 | 1.13 | 2.28 | 2.28 | 2.17 |
| 77477 | 2 x 2 x 2 | 1.37 | 1.37 | 1.37 | 2.95 | 2.95 | 2.95 |

Continued on next page

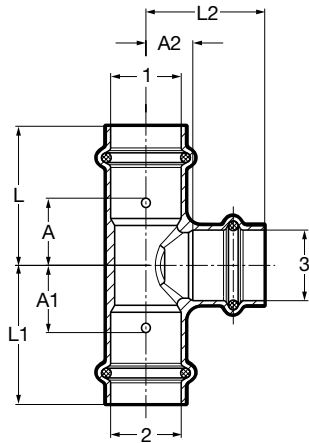
Viega ProPress Tee Copper P x P x P - Model 2918

Continued from previous page

| Part No. | Size (in) | | | A (in) | A1 (in) | A2 (in) | L (in) | L1 (in) | L2 (in) |
|----------|-----------|----------------|----------------|--------|---------|---------|--------|---------|---------|
| | 1 | 2 | 3 | | | | | | |
| 15518 | 2 | $1\frac{1}{4}$ | $1\frac{1}{4}$ | 0.94 | 1.84 | 1.33 | 2.52 | 2.87 | 2.36 |
| 15513 | 2 | $1\frac{1}{2}$ | $\frac{3}{4}$ | 0.70 | 1.25 | 1.38 | 2.28 | 2.68 | 2.28 |
| 15498 | 2 | $1\frac{1}{2}$ | 1 | 0.82 | 1.45 | 1.38 | 2.40 | 2.87 | 2.28 |
| 15508 | 2 | $1\frac{1}{2}$ | $1\frac{1}{4}$ | 0.94 | 1.55 | 1.49 | 2.52 | 2.97 | 2.52 |
| 15503 | 2 | $1\frac{1}{2}$ | $1\frac{1}{2}$ | 1.13 | 1.65 | 1.37 | 2.72 | 3.07 | 2.80 |
| 22228 | 2 | $1\frac{1}{2}$ | 2 | 1.38 | 1.89 | 1.38 | 2.95 | 3.33 | 2.95 |
| 15538 | 2 | 2 | $\frac{1}{2}$ | 0.54 | 0.54 | 1.30 | 2.13 | 2.13 | 2.05 |
| 94777 | 2 | 2 | $\frac{3}{4}$ | 0.79 | 0.79 | 1.26 | 2.37 | 2.37 | 2.17 |
| 94772 | 2 | 2 | 1 | 0.91 | 0.91 | 1.30 | 2.49 | 2.49 | 2.21 |
| 77487 | 2 | 2 | $1\frac{1}{4}$ | 1.04 | 1.04 | 1.37 | 2.62 | 2.62 | 2.40 |
| 77482 | 2 | 2 | $1\frac{1}{2}$ | 1.13 | 1.13 | 1.37 | 2.72 | 2.72 | 2.80 |

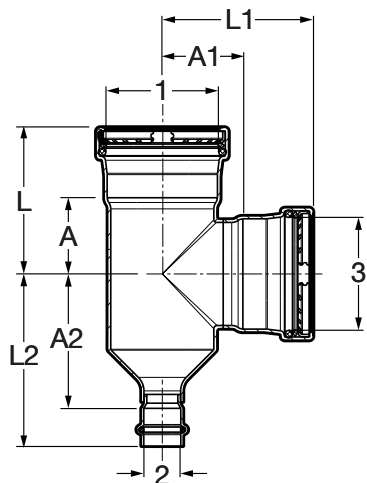
Viega ProPress Tee P x P x P - Model 0918XL

| Part No. | Size | | | A (in) | A1 (in) | A2 (in) | L (in) | L1 (in) | L2 (in) |
|----------|------|----|----|--------|---------|---------|--------|---------|---------|
| | 1 | 2 | 3 | | | | | | |
| 20684 | 2½ | ¾ | 2½ | 1.83 | 1.91 | 3.23 | 3.52 | 3.60 | 4.13 |
| 20689 | 2½ | 1 | 2½ | 1.83 | 1.91 | 3.25 | 3.52 | 3.60 | 4.15 |
| 20694 | 2½ | 1¼ | 2½ | 1.83 | 1.91 | 3.20 | 3.52 | 3.60 | 4.23 |
| 20699 | 2½ | 1½ | 2½ | 1.83 | 1.91 | 3.14 | 3.52 | 3.60 | 4.57 |
| 20704 | 2½ | 2 | ¾ | 1.04 | 1.61 | 1.59 | 2.74 | 2.52 | 3.17 |
| 20709 | 2½ | 2 | 1 | 1.04 | 1.77 | 1.65 | 2.74 | 2.67 | 3.24 |
| 22283 | 2½ | 2 | 1½ | 1.30 | 1.78 | 2.07 | 2.99 | 3.20 | 3.66 |
| 22278 | 2½ | 2 | 2 | 1.50 | 1.78 | 2.25 | 3.19 | 3.36 | 3.83 |
| 20714 | 2½ | 2 | 2½ | 1.83 | 1.91 | 2.41 | 3.52 | 3.60 | 4.00 |
| 22303 | 2½ | 2½ | ½ | 0.91 | 1.52 | 0.91 | 2.60 | 2.27 | 2.60 |
| 22298 | 2½ | 2½ | ¾ | 0.91 | 1.58 | 0.91 | 2.60 | 2.48 | 2.60 |
| 22293 | 2½ | 2½ | 1 | 1.04 | 1.77 | 1.04 | 2.74 | 2.68 | 2.74 |
| 22288 | 2½ | 2½ | 1¼ | 1.16 | 1.76 | 1.16 | 2.85 | 2.79 | 2.85 |
| 20803 | 2½ | 2½ | 1½ | 1.30 | 1.78 | 1.30 | 2.99 | 3.21 | 2.99 |
| 20688 | 2½ | 2½ | 2 | 1.54 | 1.75 | 1.54 | 3.23 | 3.34 | 3.23 |
| 20683 | 2½ | 2½ | 2½ | 1.83 | 1.94 | 1.83 | 3.52 | 3.63 | 3.52 |
| 20719 | 3 | ¾ | 3 | 2.07 | 2.15 | 3.82 | 4.04 | 4.11 | 4.72 |
| 20724 | 3 | 1 | 3 | 2.07 | 2.15 | 3.96 | 4.04 | 4.11 | 4.86 |
| 20729 | 3 | 1¼ | 3 | 2.07 | 2.15 | 3.83 | 4.04 | 4.11 | 4.86 |
| 20727 | 3 | 1½ | 3 | 2.07 | 2.15 | 3.71 | 4.04 | 4.11 | 5.14 |
| 20732 | 3 | 2 | 2 | 1.56 | 2.03 | 2.33 | 3.52 | 3.61 | 3.92 |
| 20734 | 3 | 2 | 2½ | 1.85 | 2.15 | 2.63 | 3.82 | 3.85 | 4.21 |
| 20739 | 3 | 2 | 3 | 2.07 | 2.15 | 2.84 | 4.04 | 4.11 | 4.43 |
| 20744 | 3 | 2½ | 2 | 1.56 | 2.03 | 2.07 | 3.52 | 3.61 | 3.76 |
| 20749 | 3 | 2½ | 2½ | 1.85 | 2.15 | 2.56 | 3.82 | 3.85 | 4.25 |
| 20754 | 3 | 2½ | 3 | 2.07 | 2.15 | 2.78 | 4.04 | 4.11 | 4.47 |
| 20759 | 3 | 3 | ½ | 0.93 | 1.76 | 0.93 | 2.89 | 2.50 | 2.89 |
| 22323 | 3 | 3 | ¾ | 0.93 | 1.80 | 0.93 | 2.89 | 2.71 | 2.89 |
| 22308 | 3 | 3 | 1 | 1.06 | 2.02 | 1.06 | 3.03 | 2.92 | 3.03 |
| 22313 | 3 | 3 | 1¼ | 1.18 | 2.01 | 1.18 | 3.15 | 3.04 | 3.15 |
| 20798 | 3 | 3 | 1½ | 1.32 | 2.03 | 1.32 | 3.29 | 3.45 | 3.29 |
| 20698 | 3 | 3 | 2 | 1.56 | 2.00 | 1.56 | 3.52 | 3.59 | 3.52 |
| 20703 | 3 | 3 | 2½ | 1.85 | 2.15 | 1.85 | 3.82 | 3.85 | 3.82 |
| 20693 | 3 | 3 | 3 | 2.07 | 2.21 | 2.07 | 4.04 | 4.18 | 4.04 |
| 20774 | 4 | 3 | 2 | 1.59 | 2.57 | 3.33 | 3.96 | 4.15 | 5.22 |
| 20784 | 4 | 3 | 3 | 2.11 | 2.66 | 3.84 | 4.47 | 4.63 | 5.81 |
| 20788 | 4 | 4" | ½ | 1.08 | 2.24 | 1.08 | 3.45 | 2.99 | 3.45 |
| 20793 | 4 | 4 | ¾ | 1.08 | 2.32 | 1.08 | 3.45 | 3.22 | 3.45 |
| 20794 | 4 | 4 | 1 | 1.36 | 2.52 | 1.36 | 3.72 | 3.42 | 3.72 |
| 20795 | 4 | 4 | 1¼ | 1.36 | 2.50 | 1.36 | 3.72 | 3.54 | 3.72 |
| 20808 | 4 | 4 | 1½ | 1.36 | 2.52 | 1.36 | 3.72 | 3.95 | 3.72 |
| 20713 | 4 | 4 | 2 | 1.59 | 2.53 | 1.59 | 3.96 | 4.11 | 3.96 |
| 20718 | 4 | 4 | 2½ | 1.89 | 2.65 | 1.89 | 4.25 | 4.35 | 4.25 |
| 20723 | 4 | 4 | 3 | 2.11 | 2.69 | 2.11 | 4.47 | 4.65 | 4.47 |
| 20708 | 4 | 4 | 4 | 2.60 | 2.72 | 2.60 | 4.96 | 5.09 | 4.96 |

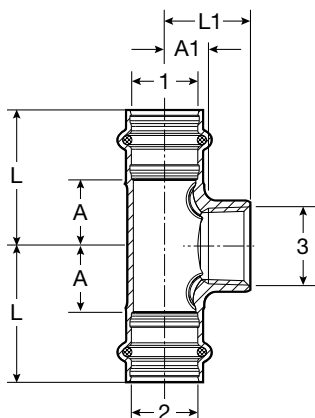
Viega ProPress Tee Zero Lead Bronze P x P x FPT - Model 2917.2ZL

| Part No. | Size (in) | | | A (in) | A1 (in) | L (in) | L1 (in) |
|----------|-----------|----|---|--------|---------|--------|---------|
| | 1 | 2 | 3 | | | | |
| 79580 | ½ | ½ | ½ | 0.79 | 0.69 | 1.61 | 1.30 |
| 79585 | ¾ | ¾ | ¼ | 0.67 | 0.79 | 1.57 | 1.18 |
| 79590 | ¾ | ¾ | ½ | 0.79 | 0.88 | 1.69 | 1.42 |
| 79595 | ¾ | ¾ | ¾ | 0.91 | 0.59 | 1.81 | 1.14 |
| 79760 | 1 | 1 | ½ | 0.79 | 1.04 | 1.69 | 1.57 |
| 79765 | 1 | 1 | ¾ | 0.91 | 1.06 | 1.81 | 1.61 |
| 79770 | 1¼ | 1¼ | ½ | 0.83 | 1.16 | 1.85 | 1.69 |
| 79775 | 1¼ | 1¼ | ¾ | 0.95 | 1.18 | 1.97 | 1.73 |
| 79780 | 1½ | 1½ | ½ | 0.87 | 1.24 | 2.28 | 1.77 |
| 79785 | 1½ | 1½ | ¾ | 0.94 | 1.30 | 2.36 | 1.85 |
| 79790 | 2 | 2 | ½ | 0.98 | 1.59 | 2.56 | 2.13 |
| 79795 | 2 | 2 | ¾ | 1.06 | 1.65 | 2.64 | 2.20 |

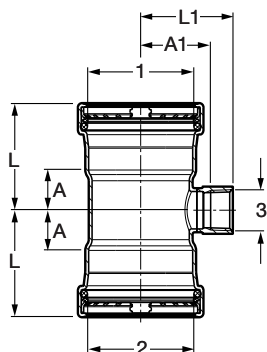
Viega ProPress Tee P x P x FPT - Model 0917.2XL

| Part No. | Size | | | A (in) | A1 (in) | L (in) | L1 (in) |
|----------|------|----|---|--------|---------|--------|---------|
| | 1 | 2 | 3 | | | | |
| 20883 | 2½ | 2½ | ¾ | 1.02 | 1.78 | 2.72 | 2.34 |
| 20878 | 2½ | 2½ | 2 | 1.54 | 1.90 | 3.23 | 2.60 |
| 20893 | 3 | 3 | ¾ | 1.04 | 2.03 | 3.01 | 2.59 |
| 20888 | 3 | 3 | 2 | 1.56 | 2.16 | 3.52 | 2.85 |
| 20873 | 4 | 4 | ¾ | 1.08 | 2.53 | 3.34 | 3.09 |
| 20868 | 4 | 4 | 2 | 1.59 | 2.69 | 3.96 | 3.38 |

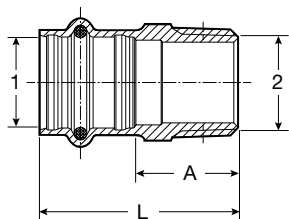
Viega ProPress Adapter Zero Lead Bronze P x MPT - Model 2911ZL

| Part No. | Size (in) | | A (in) | L (in) |
|----------|-----------|----|--------|--------|
| | 1 | 2 | | |
| 79210 | ½ | ¾ | 0.77 | 1.59 |
| 79215 | ½ | ½ | 0.89 | 1.71 |
| 79220 | ½ | ¾ | 1.00 | 1.83 |
| 79225 | ¾ | ½ | 1.02 | 1.93 |
| 79230 | ¾ | ¾ | 1.02 | 1.93 |
| 79235 | ¾ | 1 | 1.18 | 2.09 |
| 79240 | 1 | ¾ | 1.18 | 2.09 |
| 79245 | 1 | 1 | 1.26 | 2.17 |
| 79250 | 1 | 1¼ | 1.54 | 2.44 |
| 79255 | 1¼ | 1 | 1.22 | 2.24 |
| 79260 | 1¼ | 1¼ | 1.34 | 2.36 |
| 79265 | 1¼ | 1½ | 1.48 | 2.50 |
| 79270 | 1½ | 1¼ | 1.34 | 2.76 |
| 79275 | 1½ | 1½ | 1.28 | 2.70 |
| 79280 | 1½ | 2 | 1.65 | 3.07 |
| 79285 | 2 | 1½ | 1.54 | 3.11 |
| 79290 | 2 | 2 | 1.50 | 3.07 |

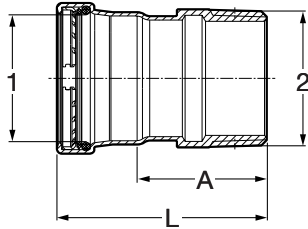
Viega ProPress Adapter P x MPT - Model 0911XL

| Part No. | Size (in) | | A (in) | L (in) |
|----------|-----------|--------|--------|--------|
| | 1 | 2 | | |
| 20823 | 2½ | 2½ MPT | 2.76 | 4.45 |
| 20828 | 3 | 3 MPT | 2.84 | 4.80 |
| 20838 | 4 | 4 MPT | 3.10 | 5.46 |

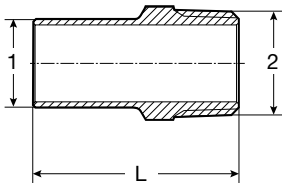
Viega ProPress Adapter Zero Lead Bronze FTG x MPT - Model 2911.1ZL

| Part No. | Size (in) | | L (in) |
|----------|-----------|--------|--------|
| | 1 | 2 | |
| 79375 | ½ | ⅜ MPT | 1.75 |
| 79380 | ½ | ½ MPT | 1.95 |
| 79385 | ½ | ¾ MPT | 2.05 |
| 79390 | ¾ | ½ MPT | 1.93 |
| 79395 | ¾ | ¾ MPT | 2.05 |
| 79400 | 1 | ¾ MPT | 2.05 |
| 79405 | 1 | 1 MPT | 2.22 |
| 79410 | 1¼ | 1¼ MPT | 2.54 |
| 79415 | 1½ | 1½ MPT | 2.89 |
| 79420 | 2 | 2 MPT | 3.33 |

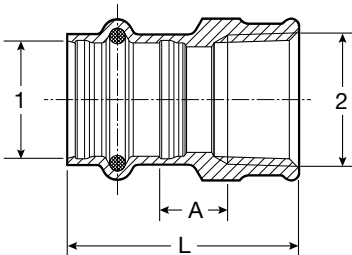
Viega ProPress Adapter Zero Lead Bronze P x FPT - Model 2912ZL

| Part No. | Size (in) | | A (in) | L (in) |
|----------|-----------|--------|--------|--------|
| | 1 | 2 | | |
| 79295 | ½ | ⅜ FPT | 0.19 | 1.42 |
| 79300 | ½ | ½ FPT | 0.25 | 1.61 |
| 79305 | ½ | ¾ FPT | 0.27 | 1.65 |
| 79310 | ¾ | ½ FPT | 0.33 | 1.77 |
| 79315 | ¾ | ¾ FPT | 0.35 | 1.81 |
| 79320 | 1 | ½ FPT | 0.41 | 1.85 |
| 79325 | 1 | ¾ FPT | 0.39 | 1.85 |
| 79330 | 1 | 1 FPT | 0.44 | 2.01 |
| 79335 | 1 | 1¼ FPT | 0.50 | 2.09 |
| 79340 | 1¼ | ½ FPT | 0.37 | 1.93 |
| 79345 | 1¼ | 1 FPT | 0.24 | 1.93 |
| 79350 | 1¼ | 1¼ FPT | 0.34 | 2.05 |
| 79355 | 1¼ | 1½ FPT | 0.42 | 2.13 |
| 79360 | 1½ | 1¼ FPT | 0.26 | 2.36 |
| 79365 | 1½ | 1½ FPT | 0.34 | 2.44 |
| 79370 | 2 | 2 FPT | 0.41 | 2.68 |

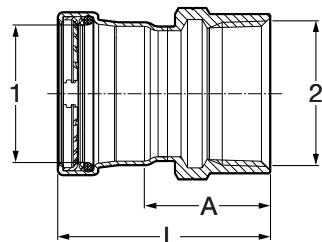
Viega ProPress Adapter P x FPT - Model 0912XL

| Part No. | Size (in) | A (in) | L (in) |
|----------|-------------|--------|--------|
| | 1 2 | | |
| 20819 | 2½ x 2½ FPT | 1.53 | 4.15 |
| 20829 | 3 x 3 FPT | 1.84 | 4.82 |
| 20839 | 4 x 4 FPT | 2.09 | 5.55 |

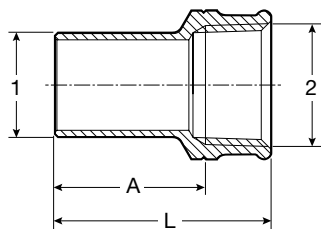
Viega ProPress Adapter Zero Lead Bronze FTG x FPT - Model 2912.1ZL

| Part No. | Size (in) | A (in) | L (in) |
|----------|-------------|--------|--------|
| | 1 2 | | |
| 79425 | ½ x ¾ FPT | 1.10 | 1.54 |
| 79430 | ½ x ½ FPT | 1.22 | 1.75 |
| 79435 | ½ x ¾ FPT | 1.30 | 1.83 |
| 79440 | ¾ x ½ FPT | 1.26 | 1.79 |
| 79445 | ¾ x ¾ FPT | 1.28 | 1.83 |
| 79455 | 1 x ½ FPT | 1.35 | 1.99 |
| 79450 | 1 x 1 FPT | 1.33 | 1.99 |
| 79460 | 1¼ x ½ FPT | 1.65 | 2.19 |
| 79465 | 1¼ x 1¼ FPT | 1.50 | 2.19 |
| 79470 | 1½ x 1½ FPT | 1.88 | 2.56 |
| 79475 | 2 x 2 FPT | 2.13 | 2.95 |

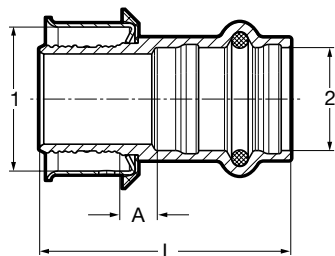
Viega PEX Press Adapter Zero Lead Bronze P x P - Model 2813PZL

| Part No. | Size (in) | A (in) | L (in) |
|----------|-----------|--------|--------|
| | 1 2 | | |
| 99620 | ½ x ½ | 0.29 | 1.61 |
| 99626 | ½ x ¾ | 0.43 | 1.83 |
| 99630 | ¾ x ½ | 0.23 | 1.56 |
| 99640 | ¾ x ¾ | 0.33 | 1.73 |
| 99645 | 1 x ¾ | 0.35 | 1.87 |
| 99660 | 1 x 1 | 0.45 | 1.97 |
| 99665 | 1¼ x 1 | 0.49 | 2.26 |
| 99670 | 1¼ x 1¼ | 0.49 | 2.38 |
| 66675 | 1½ x 1 | 0.59 | 2.36 |
| 99680 | 1½ x 1½ | 0.59 | 2.87 |
| 99685 | 2 x 1 | 0.73 | 2.68 |
| 99690 | 2 x 2 | 0.59 | 3.21 |

Viega ProPress Adapter Flange Zero Lead Bronze P x Flange - Model 2959.5ZL

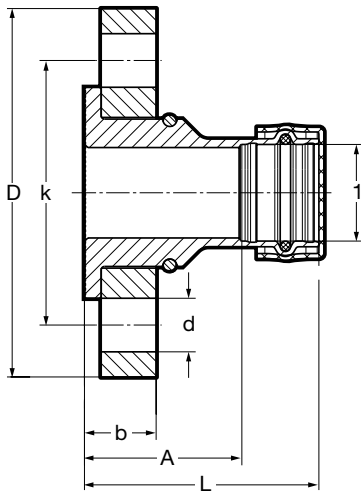

| Part No. | Size (in) | A (in) | L (in) | b (in) | D (in) | k (in) | d (in) |
|----------|-----------|--------|--------|--------|--------|--------|--------|
| 1 | | | | | | | |
| 79680 | 1 | 1.85 | 2.76 | 0.84 | 4.33 | 3.11 | 0.63 |
| 79685 | 1¼ | 1.73 | 2.76 | 0.84 | 4.53 | 3.50 | 0.63 |
| 79690 | 1½ | 1.65 | 3.07 | 0.84 | 4.92 | 3.86 | 0.63 |
| 79695 | 2 | 2.09 | 3.66 | 0.84 | 5.91 | 4.76 | 0.75 |

Viega ProPress Adapter Flange P x Flange - Model 0959.5XL

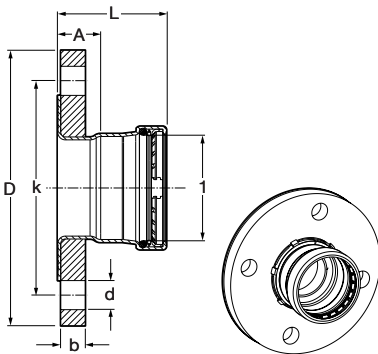

| Part No. | Size (in) | A (in) | L (in) | b (in) | k (in) | D (in) | d (in) |
|----------|-----------|--------|--------|--------|--------|--------|--------|
| 1 | | | | | | | |
| 20853 | 2½ | 1.09 | 2.79 | 0.70 | 5.51 | 7.09 | 0.75 |
| 20858 | 3 | 1.20 | 3.17 | 0.79 | 5.98 | 7.48 | 0.75 |

Viega ProPress Adapter Flange P x Flange - Model 0959.5XL

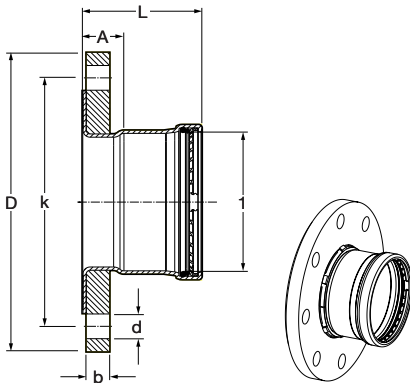

| Part No. | Size (in) | A (in) | L (in) | b (in) | k (in) | D (in) | d (in) |
|----------|-----------|--------|--------|--------|--------|--------|--------|
| 1 | | | | | | | |
| 20863 | 4 | 1.29 | 3.66 | 0.86 | 7.52 | 9.06 | 0.75 |

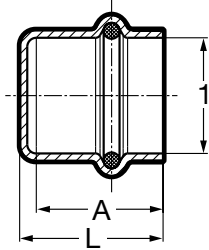
Viega ProPress Cap Copper P - Model 2956

| Part No. | Size (in) | A (in) | L (in) |
|----------|-----------|--------|--------|
| | 1 | | |
| 77712 | 1/2 | 0.79 | 0.92 |
| 77717 | 3/4 | 0.94 | 1.07 |
| 77722 | 1 | 0.99 | 1.11 |
| 77727 | 1 1/4 | 1.20 | 1.32 |
| 77732 | 1 1/2 | 1.49 | 1.62 |
| 77737 | 2 | 1.69 | 1.81 |

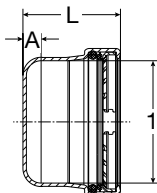
Viega ProPress Cap P - Model 0956XL

| Part No. | Size | A (in) | L (in) |
|----------|----------|--------|--------|
| | 1 | | |
| 20833 | 2 1/2 | 0.39 | 2.11 |
| 20843 | 3 | 0.39 | 2.36 |
| 20848 | 4 | 0.39 | 2.76 |

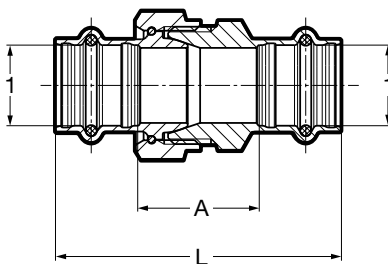
Viega ProPress Union Zero Lead Bronze P x P - Model 2960ZL

| Part No. | Size (in) | A (in) | L (in) |
|----------|-----------|--------|--------|
| | 1 | | |
| 79125 | 1/2 | 1.19 | 2.84 |
| 79130 | 3/4 | 1.34 | 3.15 |
| 79135 | 1 | 1.83 | 3.65 |
| 79140 | 1 1/4 | 1.64 | 3.69 |
| 79145 | 1 1/2 | 2.13 | 4.96 |
| 79150 | 2 | 2.07 | 5.22 |

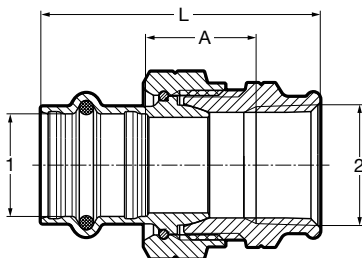
Viega ProPress Union Zero Lead Bronze P x FPT - Model 2962ZL

| Part No. | Size (in) | A (in) | L (in) |
|----------|-------------------|--------|--------|
| | 1 2 | | |
| 79700 | 1/2 x 1/2 FPT | 0.91 | 2.27 |
| 79705 | 3/4 x 3/4 FPT | 0.96 | 2.42 |
| 79710 | 1 x 1 FPT | 1.31 | 2.88 |
| 79715 | 1 1/4 x 1 1/4 FPT | 1.27 | 2.97 |
| 79720 | 1 1/2 x 1 1/2 FPT | 1.77 | 3.87 |
| 79725 | 2 x 2 FPT | 1.65 | 3.92 |

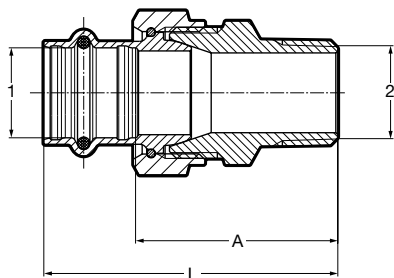
Viega ProPress Union Zero Lead Bronze P x MPT - Model 2965ZL

| Part No. | Size (in) | A (in) | L (in) |
|----------|-------------------|--------|--------|
| | 1 2 | | |
| 79730 | 1/2 x 1/2 MPT | 1.86 | 2.69 |
| 79735 | 3/4 x 3/4 MPT | 2.00 | 2.90 |
| 79740 | 1 x 1 MPT | 2.54 | 3.45 |
| 79745 | 1 1/4 x 1 1/4 MPT | 2.49 | 3.52 |
| 79750 | 1 1/2 x 1 1/2 MPT | 3.05 | 4.47 |
| 79755 | 2 x 2 MPT | 2.99 | 4.57 |

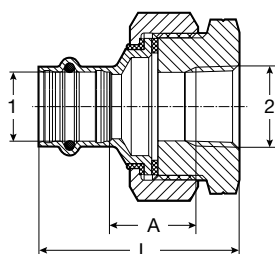
Viega ProPress Dielectric Union Zero Lead Bronze P x FPT - Model 2967ZL

| Part No. | Size (in) | A (in) | L (in) |
|----------|-------------------|--------|--------|
| | 1 2 | | |
| 79155 | 1/2 x 1/2 FPT | 0.88 | 2.24 |
| 79160 | 3/4 x 3/4 FPT | 1.11 | 2.57 |
| 79165 | 1 x 1 FPT | 1.00 | 2.57 |
| 79170 | 1 1/4 x 1 1/4 FPT | 0.97 | 2.68 |
| 79175 | 1 1/2 x 1 1/2 FPT | 1.01 | 3.11 |
| 79180 | 2 x 2 FPT | 1.26 | 3.53 |

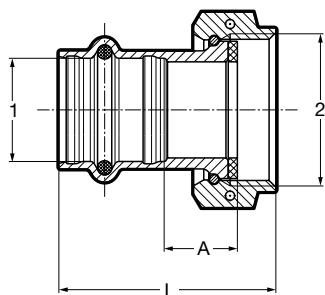
Viega ProPress Tailpiece Zero Lead Bronze P x F BSP - Model 2957ZL

| Part No. | Size (in) | A (in) | L (in) |
|----------|---------------|--------|--------|
| | 1 2 | | |
| 79800 | 1/2 x 1 BSP | 0.39 | 1.57 |
| 79805 | 3/4 x 1 BSP | 0.63 | 1.87 |
| 79810 | 1 x 1 BSP | 0.91 | 2.14 |
| 79815 | 1 x 1 1/4 BSP | 0.73 | 2.04 |

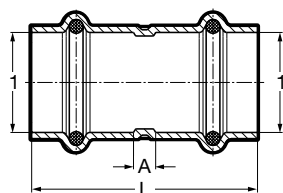
Viega ProPress Coupling with Stop Copper P x P - Model 2915

| Part No. | Size (in) | A (in) | L (in) |
|----------|---------------|--------|--------|
| | 1 1 | | |
| 78047 | 1/2 x 1/2 | 0.12 | 1.61 |
| 78052 | 3/4 x 3/4 | 0.20 | 2.01 |
| 78057 | 1 x 1 | 0.16 | 1.97 |
| 78062 | 1 1/4 x 1 1/4 | 0.14 | 2.20 |
| 78067 | 1 1/2 x 1 1/2 | 0.14 | 2.99 |
| 78072 | 2 x 2 | 0.14 | 3.31 |

Viega ProPress Coupling with Stop P x P - Model 0915XL

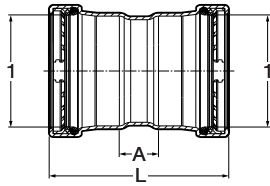

| Part No. | Size (in) | A (in) | L (in) |
|----------|-----------|--------|--------|
| | 1 1 | | |
| 20728 | 2½ x 2½ | 0.95 | 4.33 |
| 20733 | 3 x 3 | 0.98 | 4.92 |
| 20738 | 4 x 4 | 1.06 | 5.79 |

Viega ProPress Coupling No Stop Copper P x P - Model 2915.3

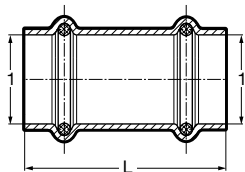

| Part No. | Size (in) | L (in) |
|----------|-----------|--------|
| | 1 1 | |
| 78172 | ½ x ½ | 1.61 |
| 78177 | ¾ x ¾ | 2.01 |
| 78182 | 1 x 1 | 1.97 |
| 78187 | 1¼ x 1¼ | 2.20 |
| 78192 | 1½ x 1½ | 2.99 |
| 78197 | 2 x 2 | 3.31 |

Viega ProPress Extended Coupling Copper P x P - Model 2915.5



| Part No. | Size (in) | L (in) |
|----------|-----------|--------|
| | 1 1 | |
| 79005 | ½ x ½ | 2.99 |
| 79010 | ¾ x ¾ | 3.50 |
| 79015 | 1 x 1 | 3.74 |
| 79020 | 1¼ x 1¼ | 4.13 |
| 79025 | 1½ x 1½ | 4.72 |
| 79030 | 2 x 2 | 5.31 |

Viega ProPress Coupling No Stop P x P - Model 0915.5XL

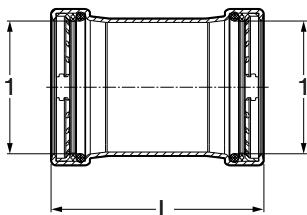

| Part No. | Size (in) | L (in) |
|----------|-----------|--------|
| | 1 1 | |
| 20743 | 2½ x 2½ | 4.33 |
| 20748 | 3 x 3 | 4.92 |
| 20753 | 4 x 4 | 5.79 |

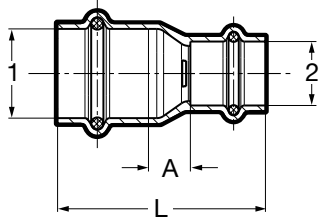
Viega ProPress Reducer Copper P x P - Model 2915.2

| Part No. | Size (in) | | A (in) | L (in) |
|----------|-----------|----|--------|--------|
| | 1 | 2 | | |
| 78147 | ¾ | ½ | 0.42 | 2.07 |
| 15603 | 1 | ½ | 0.71 | 2.36 |
| 78152 | 1 | ¾ | 0.48 | 2.29 |
| 15593 | 1½ | ¾ | 0.70 | 2.64 |
| 78157 | 1½ | 1 | 0.55 | 2.48 |
| 18473 | 1½ | ¾ | 0.98 | 3.33 |
| 15588 | 1½ | 1 | 0.74 | 3.07 |
| 78162 | 1½ | 1¼ | 0.50 | 2.96 |
| 18468 | 2 | ¾ | 1.54 | 4.02 |
| 15608 | 2 | 1 | 1.29 | 3.78 |
| 22328 | 2 | 1¼ | 0.81 | 3.43 |
| 78167 | 2 | 1½ | 0.74 | 3.75 |

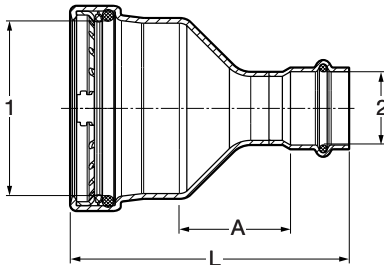
Viega ProPress Reducer P x P - Model 0915.2XL

| Part No. | Size (in) | | A (in) | L (in) |
|----------|-----------|----|--------|--------|
| | 1 | 2 | | |
| 20685 | 2½ | 1 | 1.76 | 4.36 |
| 20690 | 2½ | 1¼ | 1.61 | 4.34 |
| 20695 | 2½ | 1½ | 1.52 | 4.64 |
| 20700 | 2½ | 2 | 1.41 | 4.69 |
| 20705 | 3 | 1½ | 1.78 | 5.17 |
| 20710 | 3 | 2 | 1.53 | 5.08 |
| 20715 | 3 | 2½ | 1.41 | 5.07 |
| 20720 | 4 | 2 | 2.06 | 6.00 |
| 20725 | 4 | 2½ | 1.93 | 5.99 |
| 20730 | 4 | 3 | 1.70 | 6.03 |

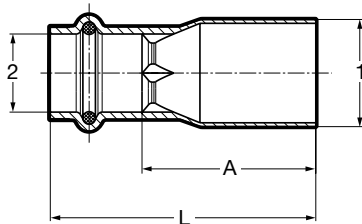
Viega ProPress Reducer Copper FTG x P - Model 2915.1

| Part No. | Size (in) | | A (in) | L (in) |
|----------|-----------|----|--------|--------|
| | 1 | 2 | | |
| 78077 | ¾ | ½ | 1.42 | 2.17 |
| 78082 | 1 | ½ | 1.69 | 2.44 |
| 78087 | 1 | ¾ | 1.42 | 2.32 |
| 22333 | 1¼ | ½ | 1.91 | 2.74 |
| 78092 | 1¼ | ¾ | 1.85 | 2.76 |
| 78097 | 1¼ | 1 | 1.57 | 2.48 |
| 14543 | 1½ | ¾ | 2.56 | 3.46 |
| 78102 | 1½ | 1 | 2.28 | 3.19 |
| 78107 | 1½ | 1¼ | 2.04 | 3.07 |
| 78112 | 2 | 1 | 3.03 | 3.94 |
| 78117 | 2 | 1¼ | 2.79 | 3.82 |
| 78122 | 2 | 1½ | 2.63 | 4.06 |

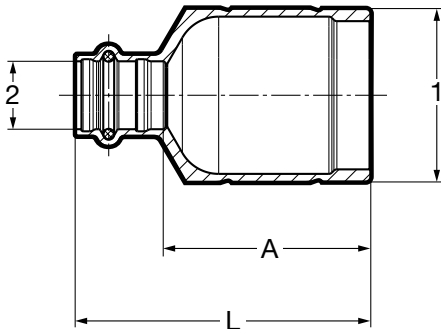
Viega ProPress Reducer Zero Lead Bronze FTG x P - Model 2915.1ZL

| Part No. | Size (in) | | A (in) | L (in) |
|----------|-----------|---|--------|--------|
| | 1 | 2 | | |
| 79850 | 1½ | ½ | 1.95 | 2.78 |
| 79855 | 2 | ½ | 2.38 | 3.21 |
| 79860 | 2 | ¾ | 2.42 | 3.33 |

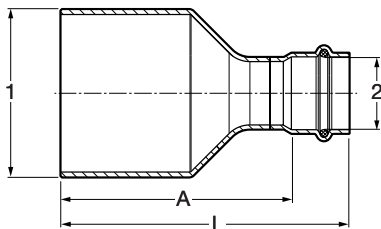
Viega ProPress Reducer FTG x P - Model 0915.1XL

| Part No. | Size (in) | | A (in) | L (in) |
|----------|-----------|----|--------|--------|
| | 1 | 2 | | |
| 20814 | 2½ | 1 | 3.61 | 4.52 |
| 20815 | 2½ | 1¼ | 3.47 | 4.51 |
| 20813 | 2½ | 1½ | 3.41 | 4.84 |
| 20758 | 2½ | 2 | 2.35 | 3.94 |
| 20817 | 3 | 1¼ | 3.96 | 5.00 |
| 20818 | 3 | 1½ | 3.91 | 5.34 |
| 20763 | 3 | 2 | 2.98 | 4.57 |
| 20768 | 3 | 2½ | 2.76 | 4.45 |
| 20773 | 4 | 2 | 4.58 | 6.17 |
| 20778 | 4 | 2½ | 4.45 | 6.15 |
| 20783 | 4 | 3 | 4.17 | 6.14 |

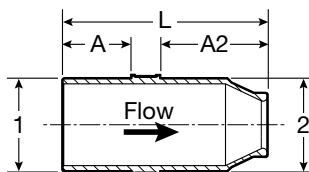
Viega ProPress Venturi Insert Zero Lead Bronze - Model 2911.5ZL

| Part No. | Size (in) | | A (in) | A2 (in) | L (in) |
|----------|-----------|----|--------|---------|--------|
| | 1 | 2 | | | |
| 78810 | 1¼ | 1¼ | 1.02 | 1.60 | 3.07 |
| 78811 | 1½ | 1½ | 1.43 | 2.10 | 3.98 |
| 78812 | 2 | 2 | 1.58 | 2.45 | 4.48 |

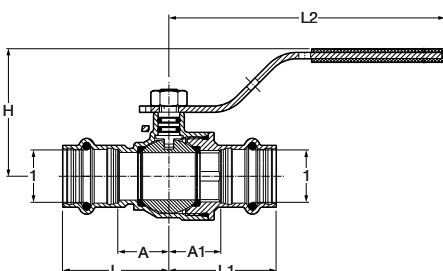
Viega ProPress Ball Valve Zero Lead Bronze P x P - Model 2971.1ZL

| Part No. | Size | | A (in) | A1 (in) | L (in) | L1 (in) | L2 (in) | H (in) |
|----------|------|----|--------|---------|--------|---------|---------|--------|
| | 1 | 1 | | | | | | |
| 79920 | ½ | ½ | 0.75 | 0.75 | 1.57 | 1.57 | 4.57 | 1.97 |
| 79925 | ¾ | ¾ | 0.85 | 0.87 | 1.75 | 1.77 | 4.57 | 2.09 |
| 79930 | 1 | 1 | 1.02 | 1.06 | 1.93 | 1.96 | 5.75 | 2.46 |
| 79935 | 1¼ | 1¼ | 1.14 | 1.12 | 2.17 | 2.15 | 5.75 | 2.67 |
| 79940 | 1½ | 1½ | 1.46 | 1.25 | 2.87 | 2.67 | 6.12 | 3.02 |
| 79950 | 2 | 2 | 1.73 | 1.47 | 3.31 | 3.05 | 6.12 | 3.32 |

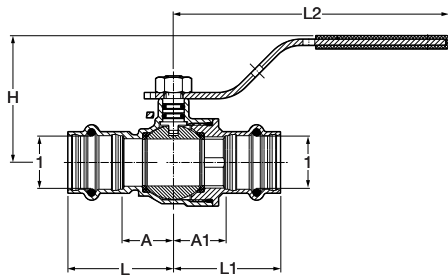
Viega ProPress Ball Valve Zero Lead Bronze P x P - Model 2971.3ZL

| Part No. | Size | | A (in) | A1 (in) | L (in) | L1 (in) | L2 (in) | H (in) |
|----------|-------|-------|--------|---------|--------|---------|---------|--------|
| | 1 | 1 | | | | | | |
| 79923 | 1/2 | 1/2 | 0.75 | 0.75 | 1.57 | 1.57 | 4.57 | 1.97 |
| 79928 | 3/4 | 3/4 | 0.85 | 0.87 | 1.75 | 1.77 | 4.57 | 2.09 |
| 79933 | 1 | 1 | 1.02 | 1.06 | 1.93 | 1.96 | 5.75 | 2.46 |
| 79938 | 1 1/4 | 1 1/4 | 1.14 | 1.12 | 2.17 | 2.15 | 5.75 | 2.67 |
| 79943 | 1 1/2 | 1 1/2 | 1.46 | 1.25 | 2.87 | 2.67 | 6.12 | 3.02 |
| 79948 | 2 | 2 | 1.73 | 1.47 | 3.31 | 3.05 | 6.12 | 3.32 |

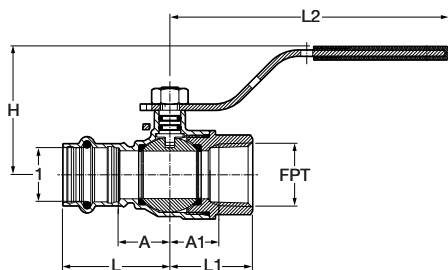
Viega ProPress Ball Valve Zero Lead Bronze P x FPT - Model 2971.4ZL

| Part No. | Size | | A (in) | A1 (in) | L (in) | L1 (in) | L2 (in) | H (in) |
|----------|------|-----|--------|---------|--------|---------|---------|--------|
| | 1 | FPT | | | | | | |
| 79970 | 1/2 | 1/2 | 0.73 | 0.66 | 1.57 | 1.20 | 4.57 | 1.97 |
| 79975 | 3/4 | 3/4 | 0.85 | 0.79 | 1.75 | 1.35 | 4.57 | 2.09 |
| 79980 | 1 | 1 | 1.02 | 0.98 | 1.93 | 1.63 | 5.75 | 2.46 |

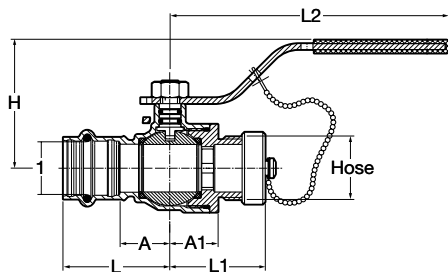
Viega ProPress Ball Valve Zero Lead Bronze P x Hose - Model 2971.6ZL

| Part No. | Size | | A (in) | A1 (in) | L (in) | L1 (in) | L2 (in) | H (in) |
|----------|------|--------|--------|---------|--------|---------|---------|--------|
| | 1 | Hose | | | | | | |
| 79875 | 1/2 | 3/4 GH | 0.75 | 0.79 | 1.57 | 1.56 | 4.57 | 1.99 |
| 79876 | 3/4 | 3/4 GH | 0.85 | 0.79 | 1.75 | 1.56 | 4.57 | 2.10 |

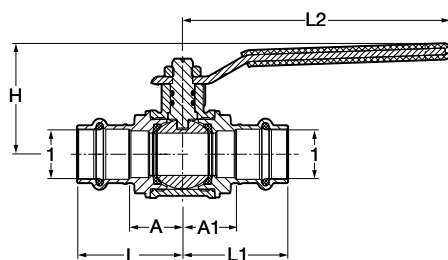
Viega ProPress Ball Valve Bronze/Brass P x P - Model 2973

| Part No. | Size (in) | | A (in) | A1 (in) | L (in) | L1 (in) | L2 (in) | H (in) |
|----------|-----------|-------|--------|---------|--------|---------|---------|--------|
| | 1 | 1 | | | | | | |
| 24000 | 1/2 | 1/2 | 0.83 | 0.83 | 1.58 | 1.58 | 3.94 | 1.69 |
| 24005 | 3/4 | 3/4 | 0.95 | 0.95 | 1.86 | 1.86 | 4.72 | 1.97 |
| 24010 | 1 | 1 | 1.18 | 1.18 | 2.09 | 2.09 | 4.72 | 2.13 |
| 24015 | 1 1/4 | 1 1/4 | 1.29 | 1.29 | 2.31 | 2.31 | 6.22 | 2.87 |
| 24020 | 1 1/2 | 1 1/2 | 1.39 | 1.39 | 2.81 | 2.81 | 6.22 | 3.11 |
| 24025 | 2 | 2 | 1.85 | 1.85 | 3.43 | 3.43 | 6.22 | 3.46 |

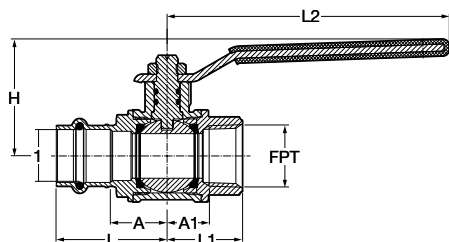
Viega ProPress Ball Valve Bronze/Brass P x FPT - Model 2973.1

| Part No. | Size (in) 1 x FPT | A (in) | A1 (in) | L (in) | L1 (in) | L2 (in) | H (in) |
|----------|----------------------|--------|---------|--------|---------|---------|--------|
| 24030 | 1/2 x 1/2 | 0.83 | 0.63 | 1.58 | 1.16 | 3.94 | 1.69 |
| 24035 | 3/4 x 3/4 | 0.95 | 0.70 | 1.86 | 1.26 | 4.72 | 1.97 |
| 24040 | 1 x 1 | 1.18 | 0.93 | 2.09 | 1.59 | 4.72 | 2.13 |

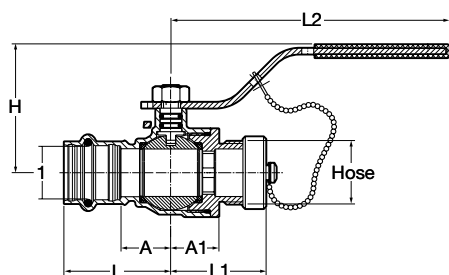
Viega ProPress Ball Valve Bronze/Brass P x Hose - Model 2973.3

| Part No. | Size (in) 1 x Hose | A (in) | A1 (in) | L (in) | L1 (in) | L2 (in) | H (in) |
|----------|-----------------------|--------|---------|--------|---------|---------|--------|
| 24090 | 1/2 x 3/4 | 0.83 | 0.85 | 1.58 | 1.30 | 3.89 | 1.67 |
| 24095 | 3/4 x 3/4 | 0.95 | 0.94 | 1.86 | 1.39 | 4.72 | 1.97 |

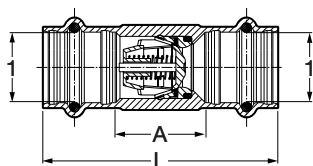
Viega ProPress Check Valve Zero Lead Bronze P x P - Model 2974ZL

| Part No. | Size | A (in) | L (in) |
|----------|---------------|--------|--------|
| | 1 1 | | |
| 79035 | 1/2 x 1/2 | 0.87 | 2.52 |
| 79040 | 3/4 x 3/4 | 1.14 | 2.95 |
| 79045 | 1 x 1 | 1.34 | 3.15 |
| 79050 | 1 1/4 x 1 1/4 | 1.69 | 3.74 |
| 79055 | 1 1/2 x 1 1/2 | 2.09 | 4.92 |
| 79060 | 2 x 2 | 2.56 | 5.71 |

Butterfly Valve - Model 2873.81

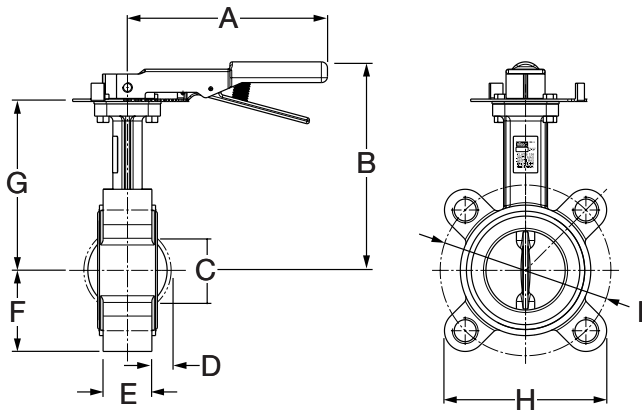

| Part No. | Size (in) | A (in) | B (in) | C (in) | D (in) | E (in) | F (in) | G (in) | H (in) | I (in) |
|----------|-----------|--------|--------|--------|--------|--------|--------|--------|--------|--------|
| 22074 | 2½ | 6.50 | 7.40 | 2.17 | 0.43 | 1.81 | 2.64 | 5.35 | 5.20 | 5.51 |
| 22075 | 3 | 7.28 | 7.64 | 2.80 | 0.67 | 1.81 | 2.82 | 5.59 | 7.01 | 5.98 |

Butterfly Valve - Model 2873.81

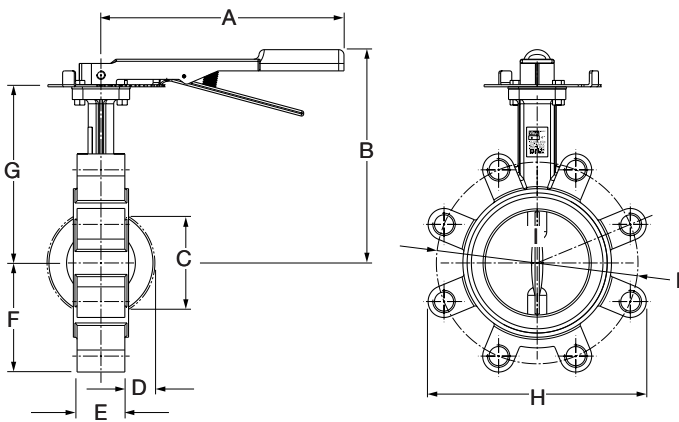

| Part No. | Size (in) | A (in) | B (in) | C (in) | D (in) | E (in) | F (in) | G (in) | H (in) | I (in) |
|----------|-----------|--------|--------|--------|--------|--------|--------|--------|--------|--------|
| 22076 | 4 | 9.06 | 8.47 | 3.54 | 0.91 | 2.05 | 3.62 | 6.42 | 8.27 | 7.48 |

Viega ProPress Automatic Recirculation Regulating Valve Zero Lead - Model 2981.3ZL

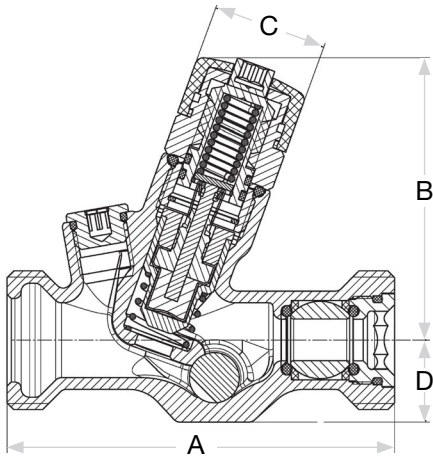

| Part No. | Size (in) | A (in) | B (in) | C (in) | D (in) |
|----------|-----------|--------|--------|--------|--------|
| 79901 | 1 | 3.66 | 3.43 | 1.09 | 0.79 |

Shower Valve - Model 2842.5

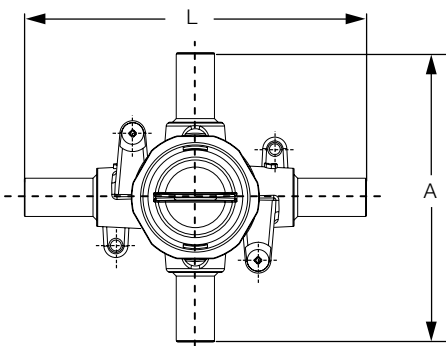

| Part No. | Stub Out (in) | A (in) | L (in) |
|----------|---------------|--------|--------|
| 93516 | 1/2 | 4.75 | 5.625 |

Shower Valve - Model 2842.6

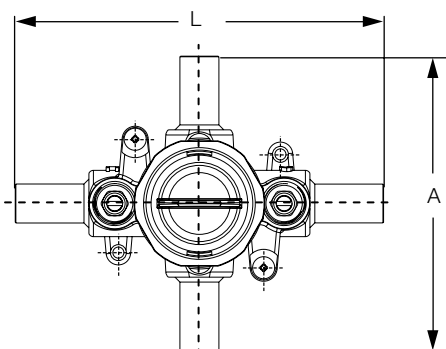

| Part No. | Stub Out (in) | A (in) | L (in) |
|----------|---------------|--------|--------|
| 93517 | 1/2 | 4.75 | 5.875 |

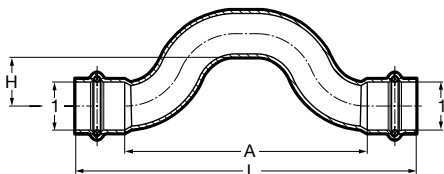
Viega ProPress Cross-Over Copper P x P - Model 2928

| Part No. | Size (in) | A (in) | L (in) | H (in) |
|----------|-----------|--------|--------|--------|
| | 1 1 | | | |
| 77742 | 1/2 x 1/2 | 3.62 | 5.12 | 0.77 |
| 77747 | 3/4 x 3/4 | 4.49 | 6.30 | 0.90 |

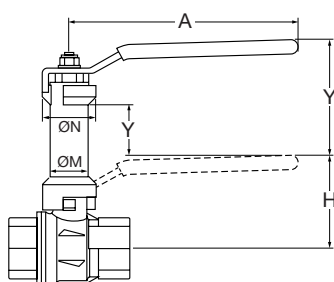
Viega ProPress Stem Extension Brass - Model 2973.96*

| Part No. | Valve Size (in) | M (in) | N (in) | A (in) | Y (in) | y (in) |
|----------|-----------------|--------|--------|--------|--------|--------|
| 23449 | 1/2 | 0.669 | 0.984 | 3.937 | 2.224 | 1.043 |
| 23451 | 3/4, 1 | 0.787 | 1.102 | 4.724 | 2.460 | 1.082 |
| 23453 | 1/4, 1 1/2, 2 | 1.023 | 1.417 | 6.220 | 2.657 | 0.807 |

*For use with Model 2973, 2973.1, and 2973.3 Valves

5 Limited Warranty

Viega ProPress Fitting and Valves

Subject to the conditions and limitations in this Limited Warranty, Viega LLC (VIEGA) warrants to wholesalers and licensed plumbing and mechanical contractors in the United States and Canada that its ProPress fittings, when properly installed in non-industrial and non-marine applications and under normal conditions of use, will be free of failure from manufacturing defect for a period of fifty (50) years from date of installation and that its ProPress valves, when properly installed in non-industrial and non-marine applications and under normal conditions of use, will be free of failure from manufacturing defect for a period of two (2) years from date of installation.

Under this Limited Warranty, you only have a right to a remedy if the failure or leak resulted from a manufacturing defect in the products covered by this warranty and the failure or leak occurred during the warranty period. You do not have a remedy under this warranty and the warranty does not apply if the failure or any resulting damage is caused by (1) components other than those manufactured or sold by Viega; (2) not designing, installing, inspecting, or testing the ProPress fittings or valves in accordance with Viega's installation instructions in effect at the time of the installation; applicable code requirements; and accepted industry practice; (3) improper handling and protection of the product prior to and during installation, inadequate freeze protection, exposure to water pressures or temperatures or in applications outside acceptable operating conditions; (4) acts of nature such as, but not limited to, earthquakes, fire, flood, or lightning, or (5) external environmental causes, such as water quality variations, aggressive water, or other external chemical or physical conditions.

In the event of a leak or other failure of the parts covered by this warranty, it is the responsibility of the property owner to obtain and pay for repairs. Only if the warranty applies will Viega be responsible for the remedy under this warranty. The part or parts which you claim failed should be kept and Viega contacted by writing to the address below or telephoning 1-800-976-9819 within thirty (30)

days after the leak or other failure and identifying yourself as having a warranty claim. You should be prepared to ship, at your expense, the product which you claim failed due to a manufacturing defect and document the date of installation. Within a reasonable time after receiving the product, Viega will investigate the reasons for the failure, which includes the right to inspect the product at Viega. Viega will notify you in writing of the results of its review.

In the event that Viega determines that the failure or leak as the result of a manufacturing defect in the part covered by this warranty and that this warranty applies, the **EXCLUSIVE AND ONLY REMEDY** under this warranty shall be the reimbursement for repair and/or replacement of the part. **VIEGA SHALL NOT BE LIABLE FOR ANY CONSEQUENTIAL OR OTHER DAMAGE (FOR EXAMPLE, WATER OR PROPERTY OR MOLD REMEDIATION) UNDER ANY LEGAL THEORY AND WHETHER ASSERTED BY DIRECT ACTION, FOR CONTRIBUTION OR INDEMNITY OR OTHERWISE.**

THE ABOVE WARRANTY IS IN LIEU OF ALL OTHER WARRANTIES, EXPRESS OR IMPLIED, INCLUDING BUT NOT LIMITED TO THE IMPLIED WARRANTIES OF MERCHANTABILITY AND FITNESS FOR A PARTICULAR PURPOSE. If a limited warranty shall be found to apply, such warranty is limited to four years. Other than this Limited Warranty, Viega does not authorize any person or firm to create for it any other obligation or liability in connection with its products.

This Limited Warranty gives you specific legal rights and you also may have other rights which may vary from state to state. This warranty shall be interpreted and applied under the law of the state in which the product is installed and is intended as a Commercial Warranty.

> Viega LLC
585 Interlocken Blvd.
Broomfield, CO 80021

Phone (800) 976-9819
www.viega.us

SM-PP 1120 ProPress Systems

