

**Submittal Package**

**Viega MegaPress® Stainless**



Project \_\_\_\_\_ Date \_\_\_\_\_

Engineer \_\_\_\_\_ Contractor \_\_\_\_\_

Submitted by \_\_\_\_\_

Approved by \_\_\_\_\_ Date \_\_\_\_\_ Approved by \_\_\_\_\_ Date \_\_\_\_\_

# Table of Contents

- Potable Water (316 only)
- Chilled Water
- Hydronic Heating
- Fire Protection (304 only)
- Low-Pressure Steam
- Compressed Air
- Industrial Gases
- Vacuum

1	<b>System Data Sheet</b> _____ <b>3</b> MegaPress 304 FKM _____ 3 MegaPress 316 _____ 4 MegaPress 316 FKM _____ 5
2	<b>Product Instructions</b> _____ <b>6</b> MegaPress Stainless ½" to 2" Fittings _____ 6 MegaPress Stainless 2½" to 4" Fittings _____ 7
3	<b>Engineering Specifications</b> _____ <b>8</b> MegaPress Stainless _____ 8
4	<b>Dimensional Documents</b> _____ <b>12</b> MegaPress Stainless Fittings _____ 12
5	<b>Limited Warranty</b> _____ <b>24</b> Viega Metal Systems for Industrial Applications _____ 24



This document is subject to updates. For the most current Viega technical literature, please visit [www.viega.us](http://www.viega.us).



Viega products are designed to be installed by licensed and trained plumbing and mechanical professionals who are familiar with Viega products and their installation. **Installation by non-professionals may void Viega LLC's warranty.**

# 1 System Data Sheet

## MegaPress 304 FKM



MegaPress 304 FKM fittings are designed to be used with standard IPS ASTM A312 stainless steel pipe to form a complete press system that is ideal for industrial applications. MegaPress 304 FKM ½" to 2" fittings can be used with Schedule 5 to Schedule 40

stainless steel pipe and 2½" to 4" fittings can be used with Schedule 10 to Schedule 40 stainless steel pipe. A MegaPress 304 FKM system can stand up to harsh environments while transporting process water, diesel fuel, lube oil, ammonia, low pressure steam, or any number of other essential fluids or gases. MegaPress 304 FKM fittings in sizes from ½" to 4" are offered in configurations including: elbows, couplings, reducers, tees, reducing tees, threaded adapters, unions, caps, and flanges.

### Components

- Alloy: 304 stainless steel
- FKM sealing element
- 420 stainless steel grip ring
- 304 stainless steel separator ring for ½" to 2" fittings
- PBT separator ring for 2½" to 4" fittings

### Operating Parameters

- Operating pressure: 200 psi max
- Operating temperatures: 14°F to 284°F (with temperature spikes up to 356°F)

### Listings and Certificates

- |                           |                                   |
|---------------------------|-----------------------------------|
| ■ ABS type approval       | ■ ICC-ES LC1002                   |
| ■ BV (Bureau Veritas)     | ■ Lloyd's Register                |
| ■ CRN 23076.5 A/B/C       | ■ FM Class 1920 (½" to 2" only)   |
| ■ DNV-GL                  | ■ ANSI/CAN/UL 213 (½" to 3" only) |
| ■ IAPMO/ANSI/CAN Z1117    |                                   |
| ■ Certified to ASTM F3226 |                                   |

### Compliant With

- ASME B31, B31.1, B31.3, B31.9
- ASTM A312
- ASTM A554
- IAPMO Uniform Mechanical Code (UMC)
- ICC International Mechanical Code (IMC)
- ICC International Residential Code (IRC)
- National Building Code of Canada (NBCC)
- National Plumbing Code of Canada (NPCC)
- NFPA 13, 13D, 13R

### Approved Applications

- |                         |                               |
|-------------------------|-------------------------------|
| ■ Low-pressure steam    | ■ Caustic solutions           |
| ■ Industrial gases      | ■ Acid solutions              |
| ■ Compress air (no oil) | ■ Vacuum                      |
| ■ Lube oil              | ■ Process water (non-potable) |

For more specific information on applications for MegaPress 304 FKM, contact Viega Technical Services at 1-800-976-9819.

MegaPress 316 systems are approved for underground installations. Viega recommends protecting both the fitting and pipe with a suitable wrap or coating to prevent corrosion. All installations must comply with local and national codes and standards.

### Recommended Tools

- Standard size press tool (minimum hydraulic ram output of 7200 lbs.)
- #56013 MegaPress jaw/ring kit (½" to 2")
- #26200 MegaPress XL PressBooster with 2½" press ring
- #57078 MegaPress XL 3" and 4" press ring kit
- #57081 Z3 Actuator with 2½" press ring (must be used with press gun with minimum 80mm press stroke)

### Smart Connect® Technology

MegaPress 304 FKM fittings are manufactured with Viega's unique Smart Connect technology. A design of the fitting, Smart Connect technology allows identification of an unpressed fitting during pressure testing.

# System Data Sheet

## MegaPress 316



MegaPress 316 fittings are designed to be used with standard IPS ASTM A312 stainless steel pipe and are ideal for industrial applications. MegaPress 316 ½" to 2" fittings can be used with Schedule 5 to Schedule 40 stainless steel pipe and 2½" to 4" fittings can be used with Schedule 10 to Schedule 40 stainless steel pipe. A MegaPress 316 system can stand up to harsh environments while transporting process water, potable water, ammonia, low pressure steam or any number of other essential fluids or gases. MegaPress 316 fittings in sizes from ½" to 4" are offered in configurations including: elbows, couplings, reducers, tees, reducing tees, threaded adapters, unions, caps and flanges.

### Components

- Alloy: 316 stainless steel
- EPDM sealing element
- 420 stainless steel grip ring
- 304 stainless steel separator ring for ½" to 2" fittings
- PBT separator ring for 2½" to 4" fittings

### Operating Parameters

- Operating pressure: 200 psi max
- Operating temperatures: 0° to 250 °F

### Listings and Certificates

- |                           |                                   |
|---------------------------|-----------------------------------|
| ■ ABS type approval       | ■ Lloyd's Register                |
| ■ BV (Bureau Veritas)     | ■ NSF®-61                         |
| ■ CRN 23076.5 A/B/C       | ■ NSF®-372                        |
| ■ DNV-GL                  | ■ FM Class 1920 (½" to 2" only)   |
| ■ IAPMO/ANSI/CAN Z1117    | ■ ANSI/CAN/UL 213 (½" to 3" only) |
| ■ ICC-ES LC1002           |                                   |
| ■ Certified to ASTM F3226 |                                   |

### Compliant With

- ASME B31, B31.1, B31.3, B31.9
- ASTM A312
- ASTM A554
- IAPMO California Plumbing Code (CPC)
- IAMPO National Standard Plumbing Code (NSPB)
- IAPMO Uniform Mechanical Code (UMC)
- IAPMO Uniform Plumbing Code (UPC)
- ICC International Mechanical Code (IMC)
- ICC International Plumbing Code (IPC)
- ICC International Residential Code (IRC)
- National Building Code of Canada (NBCC)
- National Plumbing Code of Canada (NPCC)
- NFPA 13, 13D, 13R

### Approved Applications

- |                               |                     |
|-------------------------------|---------------------|
| ■ Low-pressure steam          | ■ Caustic solutions |
| ■ Industrial gases            | ■ Acid solutions    |
| ■ Potable water               | ■ Vacuum            |
| ■ Process water (non-potable) |                     |

For more specific information on applications for MegaPress 316, contact Viega Technical Services at 1-800-976-9819.

MegaPress 316 systems are approved for underground installations. Viega recommends protecting both the fitting and pipe with a suitable wrap or coating to prevent corrosion. All installations must comply with local and national codes and standards.

### Recommended Tools

- Standard size press tool (minimum hydraulic ram output of 7200 lbs.)
- #56013 MegaPress jaw/ring kit (½" to 2")
- #26200 MegaPress XL PressBooster with 2½" press ring
- #57078 MegaPress XL 3" and 4" press ring kit
- #57081 Z3 Actuator with 2½" press ring (must be used with press gun with minimum 80mm press stroke)

### Smart Connect® Technology

MegaPress 316 fittings are manufactured with Viega's unique Smart Connect technology. A design of the fitting, Smart Connect technology allows identifications of an unpressed fitting during pressure testing.

# System Data Sheet

## MegaPress 316 FKM



MegaPress 316 FKM fittings are designed to be used with standard IPS ASTM A312 stainless steel pipe to form a complete press system that is ideal for industrial applications. MegaPress 316 FKM ½" to 2" fittings can be used with Schedule 5 to Schedule 40

stainless steel pipe and 2½" to 4" fittings can be used with Schedule 10 to Schedule 40 stainless steel pipe. A MegaPress 316 FKM system can stand up to harsh environments while transporting process water, diesel fuel, lube oil, low pressure steam, or any number of other essential fluids or gases.

MegaPress 316 FKM fittings in sizes from ½" to 4" are offered in configurations including: elbows, couplings, reducers, tees, reducing tees, threaded adapters, unions, caps, and flanges.

### Components

- Alloy: 316 stainless steel
- FKM sealing element
- 420 stainless steel grip ring
- 304 stainless steel separator ring for ½" to 2" fittings
- PBT separator ring for 2½" to 4" fittings

### Operating Parameters

- Operating pressure: 200 psi max
- Operating temperatures: 14°F to 284°F (with temperature spikes up to 356°F)

### Listings and Certificates

- ABS type approval
- CRN 23076.5 A/B/C
- IAPMO/ANSI/CAN Z1117
- ICC-ES LC1002
- Lloyd's Register
- Certified to ASTM F3226

### Compliant With

- ASME B31, B31.1, B31.3, B31.9
- ASTM A312
- ASTM A554
- IAPMO Uniform Mechanical Code (UMC)
- ICC International Mechanical Code (IMC)
- ICC International Residential Code (IRC)
- National Building Code of Canada (NBCC)
- National Plumbing Code of Canada (NPCC)

### Approved Applications

- Process water (non-potable)
- Low-pressure steam
- Industrial gases
- Compress air
- Lube oil
- Caustic solutions
- Acid solutions
- Vacuum

For more specific information on applications for MegaPress 316 FKM, contact Viega Technical Services at 1-800-976-9819.

MegaPress 316 systems are approved for underground installations. Viega recommends protecting both the fitting and pipe with a suitable wrap or coating to prevent corrosion. All installations must comply with local and national codes and standards.

### Recommended Tools

- Standard size press tool (minimum hydraulic ram output of 7200 lbs.)
- #56013 MegaPress jaw/ring kit (½" to 2")
- #26200 MegaPress XL PressBooster with 2½" press ring
- #57078 MegaPress XL 3" and 4" press ring kit
- #57081 Z3 Actuator with 2½" press ring (must be used with press gun with minimum 80mm press stroke)

### Smart Connect® Technology

MegaPress 316 FKM fittings are manufactured with Viega's unique Smart Connect technology. A design of the fitting, Smart Connect technology allows identification of an unpressed fitting during pressure testing.

## 2 Product Instructions

### MegaPress Stainless 1/2" to 2" Fittings

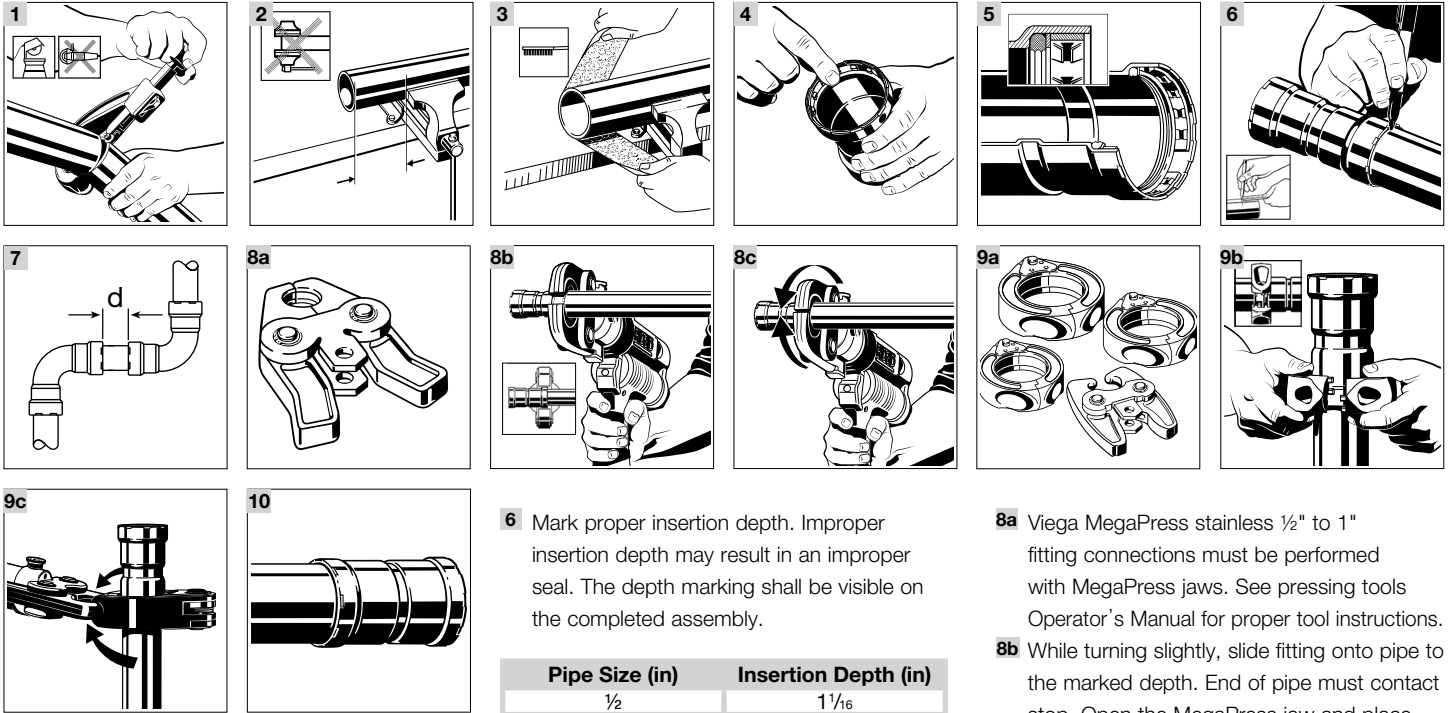

- 1 Cut pipe at right angles using displacement type cutter.
- 2 Keep end of pipe a minimum of 4" away from the contact area of the vise to prevent possible damage to the pipe in the press area. See *MegaPress Installation Manual* for minimum clearance required for prep tools.
- 3 Remove burr from inside and outside of the pipe and prep to proper insertion depth using a preparation tool or fine grit sandpaper.
- 4 Check seal, separator ring, and grip ring for correct fit. Do not use oils or lubricants.
- 5 Illustration demonstrates proper fit of grip ring, separation ring, and sealing element.

- 6 Mark proper insertion depth. Improper insertion depth may result in an improper seal. The depth marking shall be visible on the completed assembly.

Pipe Size (in)	Insertion Depth (in)
1/2	1 1/16
3/4	1 3/16
1	1 3/8
1 1/4	1 13/16
1 1/2	1 7/8
2	2

- 7 Refer to chart for minimum distance between fittings. To ensure a correct press, a minimum distance between press fittings must be maintained. Failure to provide this distance may result in an improper seal.

Pipe Diameter (in)	d (in)
1/2	1/4
3/4	1/4
1	1/4
1 1/4	1/2
1 1/2	1/2
2	1/2



**Warning!**

Keep extremities and foreign objects away from press tool during pressing operation to prevent injury or incomplete press.

- 8a Viega MegaPress stainless 1/2" to 1" fitting connections must be performed with MegaPress jaws. See pressing tools Operator's Manual for proper tool instructions.
- 8b While turning slightly, slide fitting onto pipe to the marked depth. End of pipe must contact stop. Open the MegaPress jaw and place at right angles on the fitting. Visually check insertion depth using mark on the pipe.
- 8c Start pressing process and hold the trigger until the jaw has engaged the fitting.
- 9a Viega MegaPress 1 1/4" to 2" fitting connections must be performed with MegaPress rings and V2 actuator. See Operator's Manual for proper tool instructions.
- 9b Open MegaPress ring and place at right angles on the fitting. MegaPress ring must be engaged on the fitting bead. Check insertion depth.
- 9c Place V2 actuator onto MegaPress ring and start pressing process. Hold the trigger until the actuator has engaged the MegaPress ring.
- 10 Remove MegaPress jaw from fitting or release V2 actuator from MegaPress ring and then remove MegaPress ring from the fitting on completion of press. Remove control label to indicate press has been completed.

# Product Instructions

## MegaPress Stainless 2½" to 4" Fittings

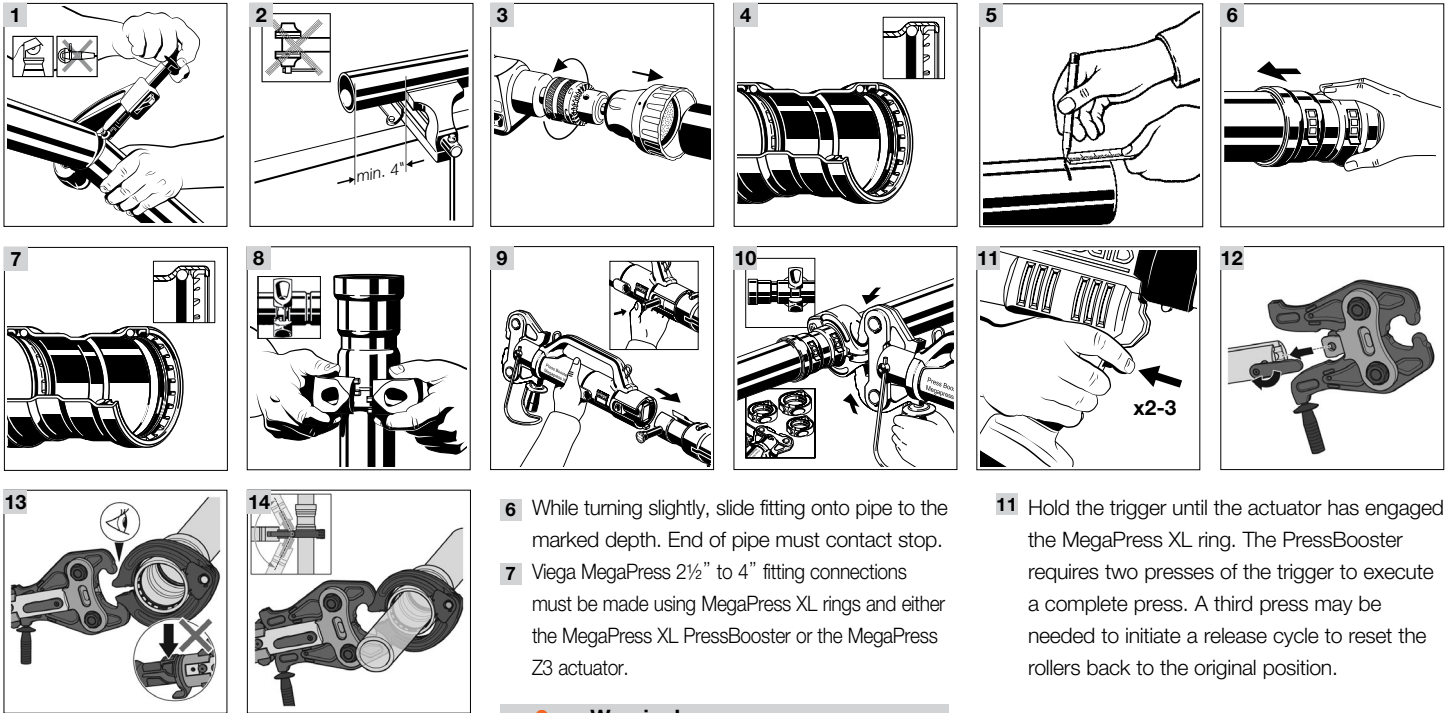

- 1 Cut pipe at right angles using displacement type cutter.
- 2 Keep end of pipe a minimum of 4" away from the contact area of the vise to prevent possible damage to the pipe in the press area.
- 3 Remove burr from inside and outside of the pipe and prep to proper insertion depth using a preparation tool or fine grit sandpaper.
- 4 Check seal, separator ring, and grip ring for correct fit. Do not use oils or lubricants. Illustration demonstrates proper fit.
- 5 Mark proper insertion depth. Improper insertion depth may result in an improper seal. It is recommended that the depth marking be visible on the completed assembly.

Insertion Depth (in)	d (in)
2½	1 <sup>13</sup> / <sub>16</sub>
3	2 <sup>5</sup> / <sub>16</sub>
4	3 <sup>1</sup> / <sub>8</sub>

- 6 While turning slightly, slide fitting onto pipe to the marked depth. End of pipe must contact stop.
- 7 Viega MegaPress 2½" to 4" fitting connections must be made using MegaPress XL rings and either the MegaPress XL PressBooster or the MegaPress Z3 actuator.

**Warning!**  
 Keep extremities and foreign objects away from press tool during pressing operation to prevent injury or incomplete press.

- 8 Open MegaPress XL ring and place at right angles on the fitting. The MegaPress XL ring must be engaged on the fitting bead. Check insertion depth.

### Pressing with MegaPress XL PressBooster

- 9 Remove the retaining bolt of the press machine. Slide the PressBooster in via the press jaw fixture. Slide the retaining bolt of the press machine in as far as it will go.
- 10 To open the PressBooster jaw, pull the handle at the hinged adapter jaw back. Place PressBooster onto the MegaPress XL ring by inserting the ball heads of the hinged adapter jaw into the contact points of the XL ring. Push the handle forward to close the hinged adapter jaw.

- 11 Hold the trigger until the actuator has engaged the MegaPress XL ring. The PressBooster requires two presses of the trigger to execute a complete press. A third press may be needed to initiate a release cycle to reset the rollers back to the original position.

### Pressing with MegaPress Z3 Actuator

- 12 On the press tool, rotate the retaining pin handle 180 degrees and pull it out to open the slot for the actuator. Insert the Viega Z3 actuator into the slot on the press tool. On the press tool, push the retaining pin back in and rotate it 180 degrees.
- 13 Open the Viega Z3 actuator by pulling the handle back. Place the open Viega Z3 actuator onto the MegaPress XL ring by inserting the ball heads of the actuator into the contact points of the XL ring. Close the Z3 actuator.
- 14 Start the pressing process by holding the press tool trigger until the actuator has engaged the XL ring. When the press cycle is complete, the actuator will stop and release.

# 3 Engineering Specifications

## MegaPress Stainless

### Part 1: General

#### 1.1 Summary

MegaPress stainless steel pipes and fittings use cold press connection technology. The system is assembled when the pipe is fully inserted into the fitting, then the fitting is pressed onto the pipe using the manufacturer's approved tooling, creating a mechanical joint. Press system for use with standard IPS ASTM A312 stainless steel pipe in sizes ½" to 4". MegaPress stainless ½" to 2" fittings can be used with Schedule 5 to Schedule 40 stainless steel pipe and 2½" to 4" fittings can be used with Schedule 10 to Schedule 40 stainless steel pipe.

#### 1.2 Definitions

ASME: American Society of Mechanical Engineers

ASTM: American Society for Testing and Materials

AWWA: American Water Works Association

EPDM: Ethylene Propylene Diene Monomer

FKM: Fluoroelastomer

IAPMO: International Association of Plumbing and Mechanical Officials

ICC: International Code Council

MSS: Manufacturers Standardization Society

NSF: National Sanitation Foundation

psi: Pounds per Square Inch

#### 1.3 References

ASME A13.1 Scheme for the Identification of Piping Systems

ASME B1.20.1 Pipe Threads, General Purpose (Inch)

ASME B31.1 Power Piping

ASME B31.3 Process Piping

ASME B31.9 Building Services Piping

ASTM A312 Standard Specification for Seamless, Welded, and Heavily Cold Worked Austenitic Stainless Steel Pipes

ASTM A403 Standard Specification for Wrought Austenitic Steel Piping Fittings.

ASTM F3226 Standard Specification for Metallic Press-Connect Fittings for Piping and Tubing Systems

AWWA C651 Standard for Disinfecting Water Mains

IAPMO Uniform Mechanical Code

IAPMO Uniform Plumbing Code

IAPMO/ANSI/CAN Z1117 Press and Nail Connections

ICC International Plumbing Code

ICC International Mechanical Code

MSS-SP-58 Pipe Hangers and Supports - Materials, Design and Manufacture

NSF 61 Drinking Water System Components – Health Effects

#### 1.4 Quality Assurance

- A. The installer shall be a qualified installer, licensed within the jurisdiction, and familiar with the installation of stainless steel pipe.
- B. The installation of stainless steel pipe for hot and cold water distribution systems shall conform to the requirements of the ICC International Plumbing Code or IAPMO Uniform Plumbing Code. The installation of stainless steel pipe in hydronic systems shall conform to the requirements of the ICC International Mechanical Code or the IAPMO Uniform Mechanical Code.

### 1.5 Delivery, Storage, and Handling

- A. Stainless steel pipe shall be shipped to the job site by truck or in such a manner to protect the pipe. The pipe and fittings shall not be handled roughly during shipment. The pipe and fittings shall be unloaded with reasonable care.
- B. Protect the stored pipe from moisture and dirt. Elevate above grade. When stored inside, do not exceed the structural capacity of the floor.
- C. Protect fittings and piping specialties from moisture and dirt.

### 1.6 Project Conditions

Verify length of pipe required by field measurements.

### 1.7 Warranty

- A. The pipe and fittings manufacturer shall warrant that the pipe and fittings are free from defects and conform to the designated standard. The warranty shall only be applicable to pipe and fittings installed in accordance with the manufacturer's installation instructions.
- B. The manufacturer of the pipe and fittings shall not be responsible for the improper use, handling, or installation of the product.

## Part 2: Products

### 2.1 Manufacturer

Viega LLC  
585 Interlocken Blvd.  
Broomfield CO, 80021  
Phone: (800) 976-9819  
www.viega.us

### 2.2 Material

- A. Pipe standard: stainless steel pipe shall conform to ASTM A312.
- B. Press fitting standard: stainless steel press fittings shall conform to the material, sizing, and performance requirements of ASTM F3226 and Z1117. O-rings for stainless steel press fittings shall be EPDM or FKM depending on the application.
- C. Threaded fitting standard: pipe threads shall conform to ASME B1.20.1.
- D. Hanger standard: hangers and supports shall conform to MSS-SP-58.

### 2.3 Source Quality Control

All pipe, fittings, and joining materials in contact with drinking water shall be listed to NSF 61.

## Part 3: Execution

### 3.1 Examination

The installing contractor shall examine the stainless steel pipe and fittings for defects or cracks. There shall be no defects of the pipe or fittings. Any damaged pipe or fittings shall be rejected.

### 3.2 Preparation

- A. Stainless steel pipe shall be cut with a wheeled pipe cutter or approved stainless steel pipe cutting tool. The pipe shall be cut square to permit proper joining with the fittings.
- B. Remove scale, slag, dirt, and debris from inside and outside of pipe and fittings before assembly. The pipe end shall be wiped clean and dry. The burrs on the pipe shall be reamed with a deburring or reaming tool.

### 3.3 Installation General Locations

Plans indicate general location and arrangement of piping systems. Identified locations and arrangements are used to size pipe and calculate friction loss, expansion, pump sizing, and other design considerations. Install piping as indicated, except where deviations to layout are approved on coordination drawings.

### 3.4 Installation

- A. Pressure rating: install components having a pressure rating equal to or greater than the system operating pressure.
- B. Install piping free of sags, bends, and kinks.
- C. Change in direction: install fittings for changes in direction and branch connections.
- D. Press connections: stainless steel press fittings shall be made in accordance with the manufacturer's installation instructions. The pipe shall be fully inserted into the fitting and the pipe marked at the shoulder of the fitting. The fitting alignment shall be checked against the mark on the pipe to assure the pipe is fully engaged (inserted) in the fitting. The joints shall be pressed using the tool approved by the manufacturer.
- E. Threaded joints: threaded joints shall have pipe joint compound or teflon tape applied to the male threads only. Tighten joint with a wrench and backup wrench as required.
- F. Pipe protection: provide protection against abrasion where stainless steel pipe is in contact with other building members by wrapping with an approved tape, pipe insulation, or otherwise suitable method of isolation.
- G. Penetration protection: provide allowance for thermal expansion and contraction of stainless steel pipe passing through a wall, floor, ceiling, or partition by wrapping with an approved tape or pipe insulation, or by installing through an appropriately sized sleeve. Penetrations of fire resistance rated assemblies shall maintain the rating of the assembly.
- H. Backfill material: backfill material shall not include any ashes, cinders, refuse, stones, boulders or other materials which can damage or break the pipe or promote corrosive action in any trench or excavation in which pipe is installed.
- I. Horizontal support: install hangers for horizontal piping in accordance with local code or the following maximum spacing and minimum rod sizes:

Nominal Pipe Size (in)	Stainless Steel Pipe Maximum Span (ft)	Minimum Rod Diameter (in)
Up to ¾	10	⅜
1	10	⅜
1¼	10	⅜
1½	10	⅜
2	10	⅜
2½	11	½
3	12	½
4	14	⅝

*All systems must be installed per local codes and/or standards and requirements. Consult the Viega Technical Support department before installing the system in other applications or applications with temperatures and/or pressures outside the stated ratings. Refer to Viega's Application Guide for more information.*

- J. Vertical support: vertical stainless steel pipe shall be supported at each floor or at 10 foot intervals.
- K. Galvanic corrosion: hangers and supports shall be either stainless steel or vinyl coated to prevent galvanic corrosion between the pipe and the supporting member.
- L. Restraint: in seismic areas, stainless steel pipe shall be installed to withstand all seismic forces.
- M. Identification: stainless steel pipe systems shall be identified in accordance with the requirements of ASME A13.1.

### 3.5 Field Quality Control

- A. Viega MegaPress Stainless fittings include Smart Connect® technology, a quick and easy way of identifying unpressed connections during the pressure testing process. The function of the feature is to provide identification of connections which have not been pressed prior to putting the system in to operation. The function of Smart Connect technology is carried out by pressurizing the piping system. Smart Connect technology may be pressure tested with air or water.
1. When testing with air, the pressure range is ½ psi to 45 psi maximum.
  2. When testing with water, the pressure range is 15 psi to 85 psi maximum.
- B. The Smart Connect technology test is not a substitute for local code required pressure testing of the piping system. Carry out the final piping system pressure test in accordance with local codes.

### 3.6 Cleaning (Potable Water Systems)

Disinfection: the stainless steel hot and cold water distribution system shall be disinfected prior to being placed in service. The system shall be disinfected in accordance with AWWA C651 or the following requirements:

- A. The piping system shall be flushed with potable water until discolored water does not appear at any of the outlets.
- B. The system shall be filled with a water chlorine solution containing between 50 and 200 parts per million of chlorine. The system shall be valved in the closed position and allowed to stand for 24 hours.
- C. Following the standing time, the system shall be flushed with water until the chlorine is purged from the system.

# 4 Dimensional Documents

## MegaPress Stainless Fittings

### MegaPress 90° Elbow, Stainless Steel, P x P - Models 4116 / 5116 / 6816

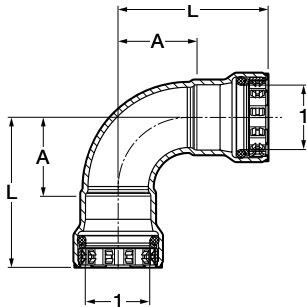

304 FKM	Part No.		Size (in)	A (in)		L (in)	
	316 EPDM	316 FKM		1	Dec	Frac	Dec
95005	90005	91695	1/2	1.13	1 1/8	2.24	2 1/4
95010	90010	91700	3/4	1.32	1 5/16	2.52	2 1/2
95015	90015	91705	1	1.69	1 11/16	3.07	3 1/16
95785	90835	91710	1 1/4	1.96	1 15/16	3.82	3 13/16
95020	90020	91715	1 1/2	2.22	2 1/4	4.13	4 1/8
95025	90025	91720	2	2.76	2 3/4	4.76	4 3/4

### MegaPress Stainless 90° Elbow P x P - Model 4116XL / 5116XL / 6816XL

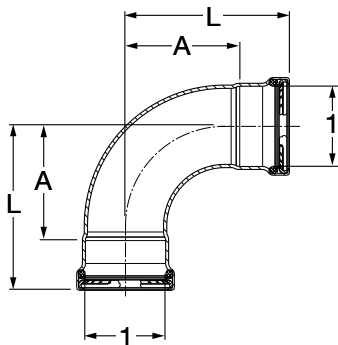

304 FKM	Part No.		Size (in)	A (in)		L (in)	
	316 EPDM	316 FKM		1	Dec	Frac	Dec
95500	90500	98405	2 1/2	4.15	4 1/8	5.94	5 15/16
95505	90505	98410	3	4.76	4 3/4	7.09	7 1/16
95510	90510	98415	4	6.00	6	9.17	9 3/16

### MegaPress 90° Elbow, Stainless Steel, FTG x P - Models 4116.1 / 5116.1 / 6816.1

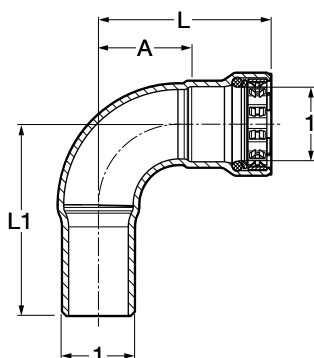

304 FKM	Part No.		Size (in)	A (in)		L (in)		L1 (in)	
	316 EPDM	316 FKM		1	Dec	Frac	Dec	Frac	Dec
95030	90030	91725	1/2	1.13	1 1/8	2.24	2 1/4	2.56	2 9/16
95035	90035	91730	3/4	1.32	1 5/16	2.52	2 1/2	2.80	2 13/16
95040	90040	91735	1	1.69	1 11/16	3.07	3 1/16	3.39	3 3/8
95845	90895	91740	1 1/4	1.96	1 15/16	3.82	3 13/16	4.04	4 1/16
95045	90045	91745	1 1/2	2.22	2 1/4	4.13	4 1/8	4.21	4 3/16
95050	90050	91750	2	2.76	2 3/4	4.76	4 3/4	5.08	5 1/16

**MegaPress Stainless 90° Street Elbow P x FTG - Model 4116.1XL / 5116.1XL / 6816.1XL**

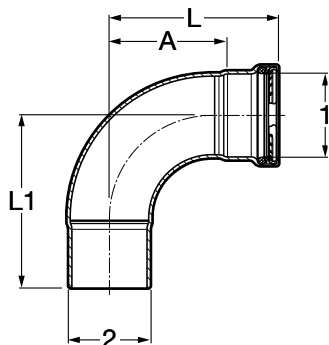

Part No.			Size (in)		A (in)		L (in)		L1 (in)	
304 FKM	316 EPDM	316 FKM	1	2	Dec	Frac	Dec	Frac	Dec	Frac
95515	90515	98390	2½ x 2½		4.15	4/8	5.94	5 <sup>15</sup> / <sub>16</sub>	6.06	6 <sup>1</sup> / <sub>16</sub>
95520	90520	98395	3 x 3		4.76	4¾	7.09	7 <sup>1</sup> / <sub>16</sub>	6.81	6 <sup>13</sup> / <sub>16</sub>
95525	90525	98400	4 x 4		6.00	6	9.17	9 <sup>3</sup> / <sub>16</sub>	8.78	8¾

**MegaPress 45° Elbow, Stainless Steel, P x P - Models 4126 / 5126 / 6826**

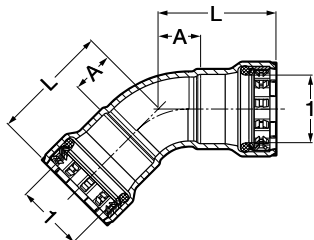

Part No.			Size (in)		A (in)		L (in)	
304 FKM	316 EPDM	316 FKM	1		Dec	Frac	Dec	Frac
95055	90055	91755	½		0.56	9/16	1.67	1 <sup>11</sup> / <sub>16</sub>
95060	90060	91760	¾		0.67	1 <sup>1</sup> / <sub>16</sub>	1.87	1 <sup>7</sup> / <sub>8</sub>
95065	90065	91765	1		0.82	1 <sup>3</sup> / <sub>16</sub>	2.20	2 <sup>3</sup> / <sub>16</sub>
95790	90840	91770	1¼		0.94	1 <sup>5</sup> / <sub>16</sub>	2.80	2 <sup>13</sup> / <sub>16</sub>
95070	90070	91775	1½		1.08	1 <sup>1</sup> / <sub>16</sub>	2.99	3
95075	90075	91780	2		1.28	1¼	3.29	3 <sup>5</sup> / <sub>16</sub>

**MegaPress Stainless 45° Elbow P x P - Model 4126XL / 5126XL / 6826XL**

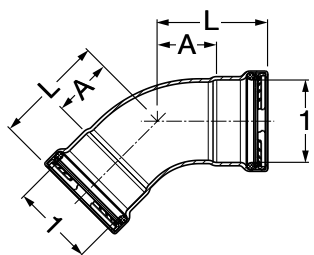

Part No.			Size (in)		A (in)		L (in)	
304 FKM	316 EPDM	316 FKM	1		Dec	Frac	Dec	Frac
95530	90530	98510	2½		2.10	2 <sup>1</sup> / <sub>8</sub>	3.90	3 <sup>7</sup> / <sub>8</sub>
95535	90535	98515	3		2.26	2¼	4.56	4 <sup>9</sup> / <sub>16</sub>
95540	90540	98520	4		2.74	2¾	5.89	5 <sup>7</sup> / <sub>8</sub>

**MegaPress 45° Elbow, Stainless Steel, FTG x P - Models 4126.1 / 5126.1 / 6826.1**

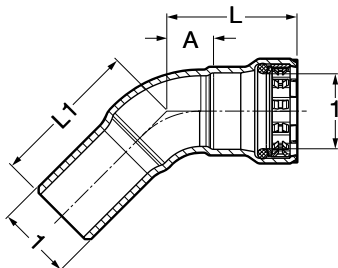

Part No.			Size (in)		A (in)		L (in)		L1 (in)	
304 FKM	316 EPDM	316 FKM	1		Dec	Frac	Dec	Frac	Dec	Frac
95080	90080	91785	½		0.56	9/16	1.67	1 <sup>11</sup> / <sub>16</sub>	1.97	2
95085	90085	91790	¾		0.67	1 <sup>1</sup> / <sub>16</sub>	1.87	1 <sup>7</sup> / <sub>8</sub>	2.13	2 <sup>1</sup> / <sub>8</sub>
95090	90090	91795	1		0.82	1 <sup>3</sup> / <sub>16</sub>	2.20	2 <sup>3</sup> / <sub>16</sub>	2.52	2½
95850	90900	91800	1¼		0.94	1 <sup>5</sup> / <sub>16</sub>	2.80	2 <sup>13</sup> / <sub>16</sub>	2.99	3
95095	90095	91805	1½		1.08	1 <sup>1</sup> / <sub>16</sub>	2.99	3	3.07	3 <sup>1</sup> / <sub>16</sub>
95100	90100	91810	2		1.28	1¼	3.29	3 <sup>5</sup> / <sub>16</sub>	3.58	3 <sup>9</sup> / <sub>16</sub>

**MegaPress Stainless 45° Street Elbow P x FTG - Model 4126.1XL / 5126.1XL / 6826.1XL**

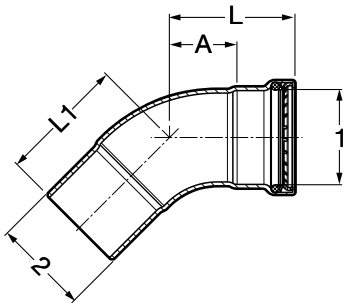

Part No.			Size (in)		A (in)		L (in)		L1 (in)	
304 FKM	316 EPDM	316 FKM	1	2	Dec	Frac	Dec	Frac	Dec	Frac
95545	90545	98495	2½	2½	2.10	2⅛	3.90	3⅞	3.95	3 <sup>15</sup> / <sub>16</sub>
95550	90550	98500	3	3	2.26	2¼	4.56	4 <sup>9</sup> / <sub>16</sub>	4.34	4 <sup>5</sup> / <sub>16</sub>
95555	90555	98505	4	4	2.74	2¾	5.89	5⅞	5.62	5 <sup>5</sup> / <sub>8</sub>

**MegaPress Stainless Tee, P x P x P - Models 4118 / 5118 / 6818**

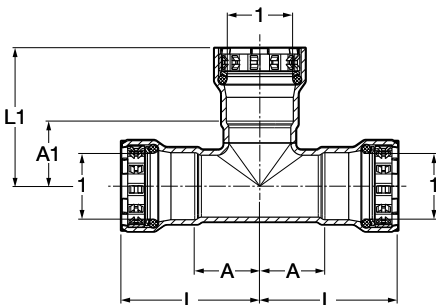

Part No.			Size (in)		A (in)		A1 (in)		L (in)		L1 (in)	
304 FKM	316 EPDM	316 FKM	1		Dec	Frac	Dec	Frac	Dec	Frac	Dec	Frac
95105	90105	91600	½		0.97	1	0.93	1 <sup>5</sup> / <sub>16</sub>	2.08	2 <sup>1</sup> / <sub>16</sub>	2.04	2 <sup>1</sup> / <sub>16</sub>
95110	90110	91605	¾		1.09	1 <sup>1</sup> / <sub>16</sub>	1.05	1 <sup>1</sup> / <sub>16</sub>	2.29	2 <sup>5</sup> / <sub>16</sub>	2.24	2 <sup>1</sup> / <sub>4</sub>
95115	90115	91610	1		1.24	1¼	1.20	1 <sup>3</sup> / <sub>16</sub>	2.63	2 <sup>5</sup> / <sub>8</sub>	2.59	2 <sup>9</sup> / <sub>16</sub>
95795	90845	91640	1¼		1.41	1 <sup>7</sup> / <sub>16</sub>	1.31	1 <sup>5</sup> / <sub>16</sub>	3.27	3¼	2.42	2 <sup>7</sup> / <sub>16</sub>
95120	90120	91615	1½		1.57	1 <sup>9</sup> / <sub>16</sub>	1.56	1 <sup>9</sup> / <sub>16</sub>	3.48	3½	3.47	3½
95125	90125	91620	2		1.81	1 <sup>13</sup> / <sub>16</sub>	1.76	1¾	3.82	3 <sup>13</sup> / <sub>16</sub>	3.77	3¾

**MegaPress Stainless Tee P x P x P - Model 4118XL / 5118XL / 6818XL**

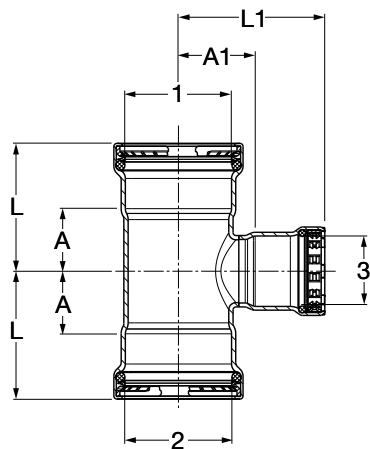

Part No.			Size (in)			A (in)		A1 (in)		L (in)		L1 (in)	
304 FKM	316 EPDM	316 FKM	1	2	3	Dec	Frac	Dec	Frac	Dec	Frac	Dec	Frac
95575	90575	98450	2½	2½	1½	1.72	1¾	2.08	2 <sup>1</sup> / <sub>16</sub>	3.52	3½	3.95	3 <sup>15</sup> / <sub>16</sub>
95580	90580	98455	2½	2½	2	2.16	2 <sup>3</sup> / <sub>16</sub>	2.05	2 <sup>1</sup> / <sub>16</sub>	3.96	3 <sup>15</sup> / <sub>16</sub>	4.04	4 <sup>1</sup> / <sub>16</sub>
95560	90560	98435	2½	2½	2½	2.16	2 <sup>3</sup> / <sub>16</sub>	2.26	2¼	3.96	3 <sup>15</sup> / <sub>16</sub>	4.06	4 <sup>1</sup> / <sub>16</sub>
95590	90590	98465	3	3	1½	1.80	1 <sup>13</sup> / <sub>16</sub>	2.33	2 <sup>5</sup> / <sub>16</sub>	4.13	4⅞	4.20	4 <sup>3</sup> / <sub>16</sub>
95585	90585	98460	3	3	2	2.11	2⅞	2.30	2 <sup>5</sup> / <sub>16</sub>	4.41	4 <sup>7</sup> / <sub>16</sub>	4.29	4 <sup>5</sup> / <sub>16</sub>
95595	90595	98470	3	3	2½	2.32	2 <sup>5</sup> / <sub>16</sub>	2.51	2½	4.63	4 <sup>5</sup> / <sub>8</sub>	4.31	4 <sup>5</sup> / <sub>16</sub>
95565	90565	98440	3	3	3	2.55	2 <sup>9</sup> / <sub>16</sub>	2.52	2½	4.88	4 <sup>7</sup> / <sub>8</sub>	4.82	4 <sup>13</sup> / <sub>16</sub>
95600	90600	98475	4	4	1½	1.86	1 <sup>7</sup> / <sub>8</sub>	2.90	2 <sup>7</sup> / <sub>8</sub>	5.04	5 <sup>1</sup> / <sub>16</sub>	4.77	4 <sup>3</sup> / <sub>4</sub>
95605	90605	98480	4	4	2	2.18	2 <sup>3</sup> / <sub>16</sub>	2.87	2 <sup>7</sup> / <sub>8</sub>	5.35	5 <sup>3</sup> / <sub>8</sub>	4.86	4 <sup>7</sup> / <sub>8</sub>
95610	90610	98485	4	4	2½	2.40	2 <sup>3</sup> / <sub>8</sub>	3.08	3 <sup>1</sup> / <sub>16</sub>	5.55	5 <sup>9</sup> / <sub>16</sub>	4.88	4 <sup>7</sup> / <sub>8</sub>
95615	90615	98490	4	4	3	2.66	2 <sup>11</sup> / <sub>16</sub>	3.13	3⅞	5.81	5 <sup>13</sup> / <sub>16</sub>	5.43	5 <sup>7</sup> / <sub>16</sub>
95570	90570	98445	4	4	4	3.22	3¼	3.08	3 <sup>1</sup> / <sub>16</sub>	6.40	6 <sup>3</sup> / <sub>8</sub>	6.26	6¼

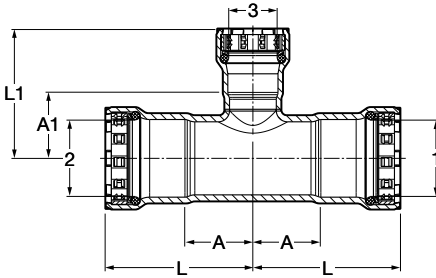
**MegaPress Reducing Tee, Stainless Steel, P x P x P - Models 4118 / 5118 / 6818**

Part No.			Size (in)			A (in)		A1 (in)		L (in)		L1 (in)	
304 FKM	316 EPDM	316 FKM	1	2	3	Dec	Frac	Dec	Frac	Dec	Frac	Dec	Frac
95130	90130	91625	3/4	x 3/4	x 1/2	1.09	1 1/16	1.02	1	2.29	2 5/16	2.13	2 1/8
95135	90135	91630	1	x 1	x 1/2	1.24	1 1/4	1.17	1 3/16	2.63	2 5/8	2.28	2 1/4
95140	90140	91635	1	x 1	x 3/4	1.24	1 1/4	1.20	1 3/16	2.63	2 5/8	2.40	2 3/8
95855	90905	91645	1 1/4	x 1 1/4	x 1/2	1.41	1 7/16	1.31	1 5/16	3.27	3 1/4	2.42	2 7/16
95860	90910	91650	1 1/4	x 1 1/4	x 3/4	1.41	1 7/16	1.35	1 3/8	3.27	3 1/4	2.55	2 9/16
95865	90915	91655	1 1/4	x 1 1/4	x 1	1.41	1 7/16	1.34	1 5/16	3.27	3 1/4	2.73	2 3/4
95145	90145	91660	1 1/2	x 1 1/2	x 1/2	1.57	1 9/16	1.42	1 7/16	3.48	3 1/2	2.53	2 1/2
95150	90150	91665	1 1/2	x 1 1/2	x 3/4	1.57	1 9/16	1.46	1 7/16	3.48	3 1/2	2.65	2 5/8
95155	90155	91670	1 1/2	x 1 1/2	x 1	1.57	1 9/16	1.45	1 7/16	3.48	3 1/2	2.84	2 13/16
NA	NA	91910	1 1/2	x 1 1/2	x 1 1/4	1.57	1 9/16	1.50	1 1/2	3.48	3 1/2	3.36	3 3/8
95160	90160	91675	2	x 2	x 1/2	1.81	1 13/16	1.72	1 3/4	3.82	3 13/16	2.83	2 13/16
95165	90165	91680	2	x 2	x 3/4	1.81	1 13/16	1.74	1 3/4	3.82	3 13/16	2.93	2 15/16
95170	90170	91685	2	x 2	x 1	1.81	1 13/16	1.70	1 11/16	3.82	3 13/16	3.09	3 1/16
NA	NA	91915	2	x 2	x 1 1/4	1.81	1 13/16	1.81	1 13/16	3.82	3 13/16	3.67	3 11/16
95175	90175	91690	2	x 2	x 1 1/2	1.81	1 13/16	1.80	1 13/16	3.82	3 13/16	3.71	3 11/16

**MegaPress Reducing Tee, Stainless Steel, P x P x FPT - Models 4117.2 / 5117.2 / 6817.2**

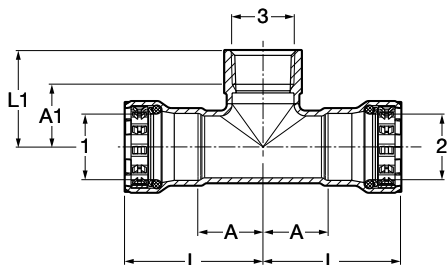

Part No.			Size (in)			A (in)		A1 (in)		L (in)		L1 (in)	
304 FKM	316 EPDM	316 FKM	1	2	3	Dec	Frac	Dec	Frac	Dec	Frac	Dec	Frac
95180	90180	91845	3/4	x 3/4	x 1/2	1.09	11/16	1.01	1	2.29	25/16	1.54	19/16
95185	90185	91850	3/4	x 3/4	x 3/4	1.09	11/16	1.02	1	2.29	25/16	1.58	19/16
95190	90190	91855	1	x 1	x 1/2	1.24	11/4	1.17	13/16	2.63	25/8	1.70	111/16
95195	90195	91860	1	x 1	x 3/4	1.24	11/4	1.17	13/16	2.63	25/8	1.73	13/4
NA	NA	91865	1 1/4	x 1 1/4	x 1/2	1.41	17/16	1.33	15/16	3.27	3 1/4	1.87	17/8
NA	NA	91870	1 1/4	x 1 1/4	x 3/4	1.41	17/16	1.33	15/16	3.27	3 1/4	1.89	17/8
NA	NA	91875	1 1/4	x 1 1/4	x 1	1.41	17/16	1.48	1 1/2	3.27	3 1/4	2.14	2 1/8
95200	90200	91880	1 1/2	x 1 1/2	x 1/2	1.57	19/16	1.40	13/8	3.48	3 1/2	1.94	115/16
95205	90205	91885	1 1/2	x 1 1/2	x 3/4	1.57	19/16	1.41	17/16	3.48	3 1/2	1.96	115/16
95210	90210	91890	1 1/2	x 1 1/2	x 1	1.57	19/16	1.55	19/16	3.48	3 1/2	2.21	23/16
95215	90215	91895	2	x 2	x 1/2	1.81	113/16	1.72	13/4	3.82	313/16	2.26	2 1/4
95220	90220	91900	2	x 2	x 3/4	1.81	113/16	1.70	11 1/16	3.82	313/16	2.26	2 1/4
95225	90225	91905	2	x 2	x 1	1.81	113/16	1.89	1 7/8	3.82	313/16	2.55	29/16

**MegaPress Stainless Tee P x P x FPT - Model 4117.2XL / 5117.2XL / 6817.2XL**

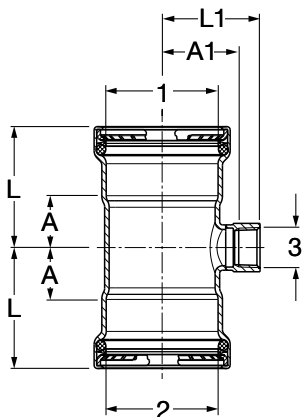

Part No.			Size (in)			A (in)		A1 (in)		L (in)		L1 (in)	
304 FKM	316 EPDM	316 FKM	1	2	3	Dec	Frac	Dec	Frac	Dec	Frac	Dec	Frac
95620	90620	98420	2 1/2	x 2 1/2	x 3/4	1.35	13/8	2.00	2	3.15	3 1/8	2.55	29/16
95625	90625	98425	3	x 3	x 3/4	1.44	17/16	2.24	2 1/4	3.74	3 3/4	2.80	213/16
95630	90630	98430	4	x 4	x 3/4	1.55	19/16	2.76	2 3/4	4.72	4 3/4	3.31	35/16

**MegaPress Adapter, Stainless Steel, P x MPT - Models 4111 / 5111 / 6811**

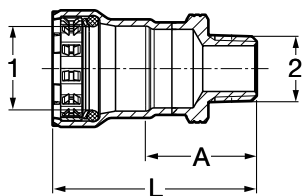

Part No.			Size (in)		A (in)		L (in)	
304 FKM	316 EPDM	316 FKM	1	2	Dec	Frac	Dec	Frac
95230	90230	91205	1/2	1/2	1.42	17/16	2.53	2 1/2
95235	90235	91210	3/4	1/2	1.43	17/16	2.63	2 5/8
95240	90240	91215	3/4	3/4	1.46	17/16	2.66	2 11/16
95245	90245	91220	1	1	1.63	1 5/8	3.02	3
95830	90880	91225	1 1/4	1 1/4	1.85	1 7/8	3.70	3 11/16
95250	90250	91230	1 1/2	1 1/2	1.92	1 15/16	3.73	3 3/4
95255	90255	91235	2	2	1.89	1 7/8	3.90	3 7/8

**MegaPress Stainless Adapter P x MPT - Model 4111XL / 5111XL / 6811XL**

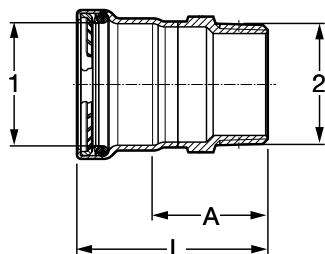

Part No.			Size (in)		A (in)		L (in)	
304 FKM	316 EPDM	316 FKM	1	2	Dec	Frac	Dec	Frac
95635	90635	98300	2 1/2	2 1/2	2.75	2 3/4	4.55	4 9/16
95640	90640	98305	3	3	2.89	2 7/8	5.20	5 3/16
95735	90735	98310	4	4	3.03	3	6.21	6 3/16

**MegaPress Adapter, Stainless Steel, P x FPT - Models 4112 / 5112 / 6812**

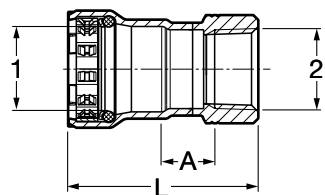

Part No.			Size (in)		A (in)		L (in)	
304 FKM	316 EPDM	316 FKM	1	2	Dec	Frac	Dec	Frac
95260	90260	91240	1/2	1/2	0.67	1 1/16	2.31	2 5/16
95265	90265	91245	3/4	3/4	0.68	1 1/16	2.43	2 7/16
95270	90270	91250	1	1	0.71	1 1/16	2.76	2 3/4
95835	90885	91255	1 1/4	1 1/4	0.73	3/4	3.27	3 1/4
95275	90275	91260	1 1/2	1 1/2	0.73	3/4	3.22	3 1/4
95280	90280	91265	2	2	0.73	3/4	3.44	3 7/16

**MegaPress Stainless Adapter P x FPT - Model 4112XL / 5112XL / 6812XL**

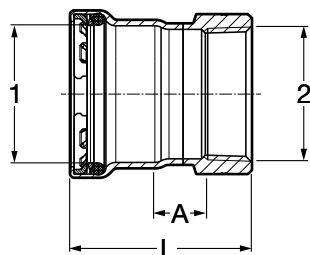

Part No.			Size (in)		A (in)		L (in)	
304 FKM	316 EPDM	316 FKM	1	2	Dec	Frac	Dec	Frac
95770	90740	98315	2 1/2	2 1/2	1.13	1 1/8	3.86	3 7/8
95775	90745	98320	3	3	1.17	1 3/16	4.49	4 1/2
95780	90750	98325	4	4	1.15	1 1/8	5.42	5 7/16

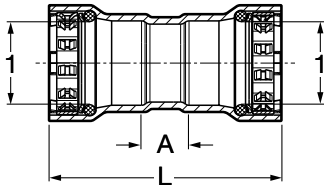
**MegaPress Coupling with Stop, Stainless Steel, P x P - Models 4115 / 5115 / 6815**

Part No.			Size (in)	A (in)		L (in)	
304 FKM	316 EPDM	316 FKM	1	Dec	Frac	Dec	Frac
95285	90285	91100	1/2	0.56	9/16	2.78	2 3/4
95290	90290	91105	3/4	0.62	5/8	3.01	3
95295	90295	91110	1	0.60	5/8	3.39	3 3/8
95800	90850	91115	1 1/4	0.70	1 1/16	4.42	4 7/16
95300	90300	91120	1 1/2	0.89	7/8	4.71	4 1 1/16
95305	90305	91125	2	0.80	13/16	4.82	4 13/16

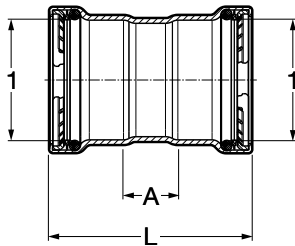
**MegaPress Stainless Coupling with Stop P x P - Model 4115XL / 5115XL / 6815XL**

Part No.			Size (in)	A (in)		L (in)	
304 FKM	316 EPDM	316 FKM	1	Dec	Frac	Dec	Frac
95645	90645	98375	2 1/2	1.32	1 5/16	4.92	4 15/16
95650	90650	98380	3	1.38	1 3/8	5.98	6
95655	90655	98385	4	1.57	1 9/16	7.87	7 7/8

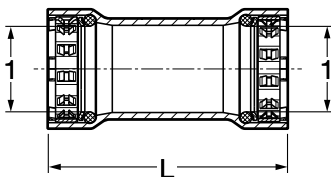
**MegaPress Coupling No Stop, Stainless Steel, P x P - Models 4115.5 / 5115.5 / 6815.5**

Part No.			Size (in)	L (in)	
304 FKM	316 EPDM	316 FKM	1	Dec	Frac
95310	90310	91290	1/2	2.78	2 3/4
95315	90315	91295	3/4	3.01	3
95320	90320	91300	1	3.37	3 3/8
95805	90855	91305	1 1/4	4.42	4 7/16
95325	90325	91310	1 1/2	4.71	4 1 1/16
95330	90330	91315	2	4.82	4 13/16

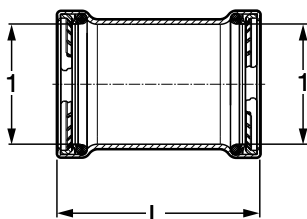
**MegaPress Stainless Coupling No Stop P x P - Model 4115.5XL / 5115.5XL / 6815.5XL**

Part No.			Size (in)	L (in)	
304 FKM	316 EPDM	316 FKM	1	Dec	Frac
95660	90660	98360	2 1/2	4.92	4 15/16
95665	90665	98365	3	5.98	6
95670	90670	98370	4	7.91	7 15/16

**MegaPress Reducer, Stainless Steel, P x P - Models 4115.2 / 5115.2 / 6815.2**

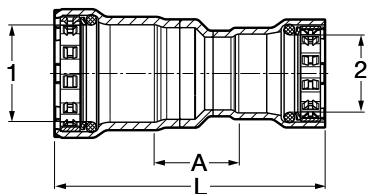

Part No.			Size (in)		A (in)		L (in)	
304 FKM	316 EPDM	316 FKM	1	2	Dec	Frac	Dec	Frac
95335	90335	91270	3/4	x 1/2	1.14	1/8	3.45	37/16
95340	90340	91275	1	x 3/4	1.18	13/16	3.76	33/4
95820	90870	91280	1 1/4	x 1	1.19	13/16	4.43	47/16
95345	90345	91920	1 1/2	x 1	1.28	1/4	5.05	5 1/16
95350	90350	91285	2	x 1 1/2	1.39	13/8	5.31	53/8

**MegaPress Reducer, Stainless Steel, FTG x P - Models 4115.1 / 5115.1 / 6815.1**

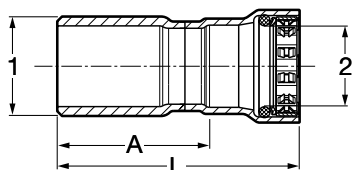

Part No.			Size (in)		A (in)		L (in)	
304 FKM	316 EPDM	316 FKM	1	2	Dec	Frac	Dec	Frac
95355	90355	91130	3/4	x 1/2	1.85	17/8	2.96	2 15/16
95360	90360	91135	1	x 1/2	2.13	2 1/8	3.24	3 1/4
95365	90365	91140	1	x 3/4	2.03	2	3.22	3 1/4
NA	NA	91320	1 1/4	x 3/4	2.80	2 13/16	4.00	4
95810	90860	91145	1 1/4	x 1	2.64	2 5/8	4.02	4
95370	90370	91160	1 1/2	x 3/4	2.95	2 15/16	4.15	4 1/8
95375	90375	91150	1 1/2	x 1	2.80	2 13/16	4.19	4 3/16
95815	90865	91155	1 1/2	x 1 1/4	2.66	2 11/16	4.52	4 1/2
95380	90380	91165	2	x 1	3.11	3 1/8	4.50	4 1/2
NA	NA	91325	2	x 1 1/4	3.00	3	4.85	4 7/8
95385	90385	91170	2	x 1 1/2	2.94	2 15/16	4.85	4 7/8

**MegaPress Stainless Reducer FTG x P - Model 4115.1XL / 5115.1XL / 6815.1XL**

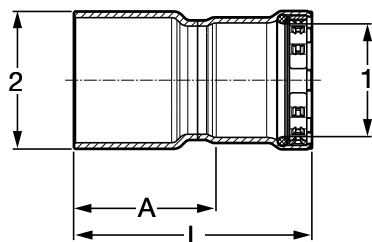

Part No.			Size (in)		A (in)		L (in)	
304 FKM	316 EPDM	316 FKM	1	2	Dec	Frac	Dec	Frac
95675	90675	98330	2	x 2 1/2	2.97	3	4.96	4 15/16
95680	90680	98335	2	x 3	3.76	3 3/4	5.75	5 3/4
95685	90685	98340	2 1/2	x 3	3.75	3 3/4	5.55	5 9/16
95690	90690	98345	2	x 4	5.28	5 1/4	7.27	7 1/4
95695	90695	98350	2 1/2	x 4	5.27	5 1/4	7.06	7 1/16
95700	90700	98355	3	x 4	5.03	5	7.33	7 5/16

**MegaPress Union, Stainless Steel, P x P - Models 4160 / 5160 / 6860**

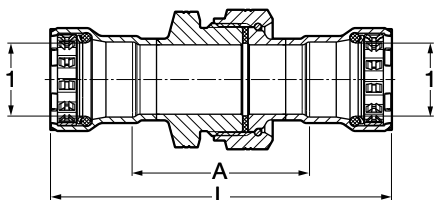

Part No.			Size (in)		A (in)		L (in)	
304 FKM	316 EPDM	316 FKM	1	2	Dec	Frac	Dec	Frac
95415	90415	91925	1/2		2.31	25/16	4.53	4 1/2
95420	90420	91930	3/4		2.59	29/16	4.98	5
95425	90425	91935	1		2.60	2 5/8	5.37	5 3/8
95875	90925	91940	1 1/4		2.76	2 3/4	6.48	6 1/2
95430	90430	91945	1 1/2		2.89	2 7/8	6.71	6 1/16
95435	90435	91950	2		3.61	3 5/8	7.63	7 5/8

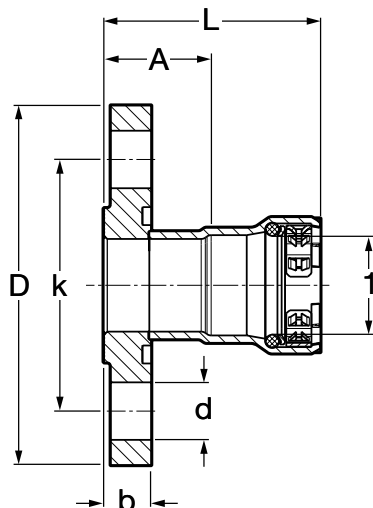
**MegaPress Stainless Flange, P x BP – Models 4159 / 5159 / 6859**

Part No.			Size (in)	A (in)		L (in)		b (in)		k (in)		D (in)		d (in)	
304 FKM	316 EPDM	316 FKM		1	Dec	Frac	Dec	Frac	Dec	Frac	Dec	Frac	Dec	Frac	Dec
95440	90440	91175	1/2	1.05	11/16	2.16	23/16	0.46	7/16	2.36	23/8	3.54	39/16	0.63	5/8
95445	90445	91180	3/4	1.19	13/16	2.39	23/8	0.53	1/2	2.76	23/4	3.94	315/16	0.63	5/8
95450	90450	91185	1	1.30	15/16	2.68	211/16	0.58	9/16	3.11	31/8	4.33	45/16	0.63	5/8
95870	90920	91190	1 1/4	1.39	13/8	3.24	31/4	0.64	5/8	3.50	31/2	4.53	41/2	0.63	5/8
95455	90455	91195	1 1/2	1.45	17/16	3.36	33/8	0.70	11/16	3.86	37/8	4.92	415/16	0.63	5/8
95460	90460	91200	2	1.48	1 1/2	3.49	31/2	0.77	3/4	4.76	43/4	5.91	515/16	0.75	3/4

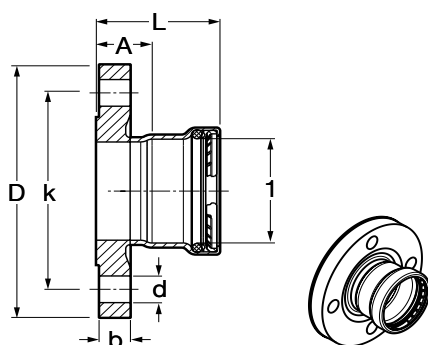
**MegaPress Stainless 2 1/2" to 4" Adapter Flange, P – Models 4159XL / 5159XL / 6859XL**

Part No.			Size (in)	A (in)		L (in)		b (in)		k (in)		D (in)		d (in)	
304 FKM	316 EPDM	316 FKM		1	Dec	Frac	Dec	Frac	Dec	Frac	Dec	Frac	Dec	Frac	Dec
95720	90720	98525	2 1/2	1.54	19/16	3.33	35/16	0.89	7/8	5.51	51/2	7.09	71/16	0.75	3/4
95725	90725	98530	3	1.65	15/8	3.95	315/16	0.96	15/16	5.98	6	7.48	71/2	0.75	3/4

**MegaPress Stainless 2½" to 4" Adapter Flange, P – Models 4159XL / 5159XL / 6859XL**

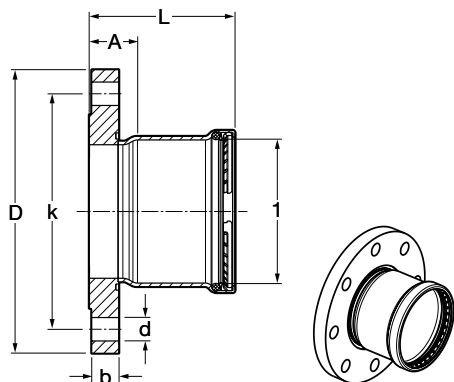

Part No.			Size (in)	A (in)		L (in)		b (in)		k (in)		D (in)		d (in)	
304 FKM	316 EPDM	316 FKM	1	Dec	Frac	Dec	Frac	Dec	Frac	Dec	Frac	Dec	Frac	Dec	Frac
95730	90730	98535	4	1.63	1 <sup>5</sup> / <sub>8</sub>	4.80	4 <sup>13</sup> / <sub>16</sub>	0.96	1 <sup>5</sup> / <sub>16</sub>	7.52	7 <sup>1</sup> / <sub>2</sub>	9.06	9 <sup>1</sup> / <sub>16</sub>	0.75	3 <sup>1</sup> / <sub>4</sub>

**MegaPress Stainless Cap, P x Cap – Models 4156 / 5156 / 6856**

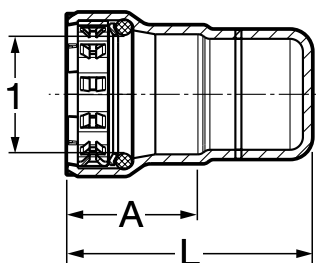

Part No.			Size (in)	A (in)		L (in)	
304 FKM	316 EPDM	316 FKM	1	Dec	Frac	Dec	Frac
95390	90390	91815	½	1.07	1 <sup>1</sup> / <sub>16</sub>	2.14	2 <sup>1</sup> / <sub>8</sub>
95395	90395	91820	¾	1.16	1 <sup>3</sup> / <sub>16</sub>	2.26	2 <sup>1</sup> / <sub>4</sub>
95400	90400	91825	1	1.35	1 <sup>3</sup> / <sub>8</sub>	2.43	2 <sup>7</sup> / <sub>16</sub>
95825	90875	91830	1¼	1.86	1 <sup>7</sup> / <sub>8</sub>	2.93	2 <sup>15</sup> / <sub>16</sub>
95405	90405	91835	1½	1.87	1 <sup>7</sup> / <sub>8</sub>	3.02	3
95410	90410	91840	2	1.99	2	3.11	3 <sup>1</sup> / <sub>8</sub>

**MegaPress Stainless Cap, P – Models 4156.1XL / 5156.1XL / 6856.1XL**

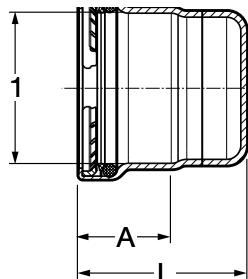

Part No.			Size (in)	A (in)		L (in)	
304 FKM	316 EPDM	316 FKM	1	Dec	Frac	Dec	Frac
95705	90705	98540	2½	1.80	1 <sup>13</sup> / <sub>16</sub>	3.27	3 <sup>1</sup> / <sub>4</sub>
95710	90710	98545	3	2.30	2 <sup>5</sup> / <sub>16</sub>	3.82	3 <sup>13</sup> / <sub>16</sub>
95715	90715	98550	4	3.18	3 <sup>3</sup> / <sub>16</sub>	4.67	4 <sup>1</sup> / <sub>16</sub>

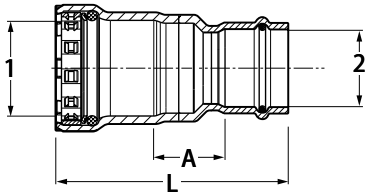
**MegaPress Stainless to ProPress Transition Coupling, P x P - Models 4113 / 5113**

Part No.		Size (in)		A (in)		L (in)	
304 FKM	316 EPDM	1 (IPS)	2 (CTS)	Dec	Frac	Dec	Frac
95465	90465	1/2	x 1/2	1.07	1 1/16	2.93	2 15/16
95470	90470	3/4	x 3/4	1.07	1 1/16	3.17	3 3/16
95475	90475	1	x 1	1.11	1 1/8	3.40	3 3/8
95840	90890	1 1/4	x 1 1/4	1.11	1 1/8	4.00	4
95485	90485	1 1/2	x 1 1/2	1.21	1 3/16	4.55	4 9/16
95490	90490	2	x 2	1.23	1 1/4	4.82	4 13/16

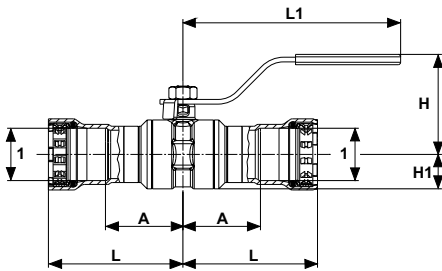
**Viega MegaPress Stainless Ball Valve, P x P - Model 4170 / 4170XL / 5170 / 5170XL**

Part No.		Size (in)		A (in)		L (in)		L1 (in)		H (in)		H1 (in)		
304 FKM	316 EPDM	1	Dec	Frac	Dec	Frac	Dec	Frac	Dec	Frac	Dec	Frac	Dec	Frac
29005	28975	1/2	1.535	1 9/16	2.618	2 5/8	4.567	4 9/16	1.992	2	0.634	5/8		
29010	28980	3/4	1.638	1 5/8	2.795	2 13/16	4.567	4 9/16	2.102	2 1/8	0.748	3/4		
29015	28985	1	1.811	1 13/16	3.157	3 1/8	5.768	5 3/4	2.469	2 7/16	0.878	7/8		
29020	28990	1 1/4	1.976	2	3.795	3 13/16	5.768	5 3/4	2.709	2 11/16	1.142	1 1/8		
29025	28995	1 1/2	2.142	2 1/8	4.012	4	6.122	6 1/8	3.016	3	1.358	1 1/8		
29030	29000	2	2.382	2 3/8	4.370	4 3/8	6.122	6 1/8	3.315	3 5/16	1.654	1 5/8		
86820	86805	2 1/2	3.717	3 11/16	5.516	5 9/16	11.087	11	5.142	5 1/8	2.256	2 1/4		
86825	86810	3	4.094	4 1/16	6.398	6 3/8	11.087	11	5.535	5 9/16	2.657	2 11/16		
86830	86815	4	4.638	4 5/8	7.843	7 13/16	13.055	13 1/16	6.697	6 11/16	3.346	3 3/8		

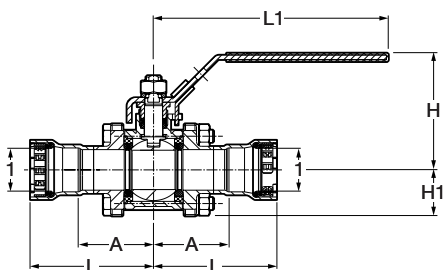
**MegaPress Stainless 3-Piece Ball Valve, P x P – Models 4175.8 / 4175.8XL / 5175.8 / 5175.8XL**

Part No.		Size (in)		A (in)		L (in)		L1 (in)		H (in)		H1 (in)		
304 FKM	316 EPDM	1	Dec	Frac	Dec	Frac	Dec	Frac	Dec	Frac	Dec	Frac	Dec	Frac
86500	86530	1/2	1.72	1 3/4	2.80	2 13/16	5.88	5 7/8	2.85	2 7/8	1.04	1 1/16		
86505	86535	3/4	1.91	1 15/16	3.06	3 1/16	5.88	5 7/8	2.93	2 15/16	1.16	1 3/16		
86510	86540	1	2.19	2 3/16	3.54	3 9/16	7.54	7 9/16	3.33	3 5/16	1.40	1 3/8		
86515	86545	1 1/4	2.50	2 1/2	4.31	4 5/16	7.54	7 9/16	3.57	3 9/16	1.57	1 9/16		
86520	86550	1 1/2	2.92	2 15/16	4.79	4 13/16	7.54	7 9/16	3.89	3 7/8	1.83	1 13/16		
86525	86555	2	3.09	3 1/16	5.07	5 1/16	7.54	7 9/16	3.89	3 7/8	1.83	1 13/16		
86650	86665	2 1/2	3.74	3 3/4	5.54	5 9/16	11.06	11 1/16	5.08	5 1/16	2.28	2 1/4		
86655	86670	3	4.37	4 3/8	6.67	6 11/16	11.06	11 1/16	5.47	5 1/2	2.68	2 11/16		
86660	86675	4	4.88	4 7/8	8.06	8 1/16	13.07	13 1/16	6.89	6 7/8	3.79	3 13/16		

Sizes up to 3" have 4 bolt flanges; 4" has 6 bolt flanges.

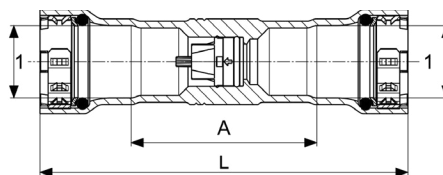
**Viega MegaPress 316 Check Valve, P x P – Model 5174**

Part No.	Size (in)	A (in)		L (in)	
316 EPDM	1	Dec	Frac	Dec	Frac
29050	1/2	2.244	2 1/4	4.488	4 1/2
29055	3/4	2.323	2 5/16	4.685	4 11/16
29060	1	2.717	2 11/16	5.472	5 1/2
29065	1 1/4	2.992	3	6.732	6 3/4
29070	1 1/2	3.346	3 3/8	7.165	7 3/16
29075	2	3.937	3 15/16	7.953	8

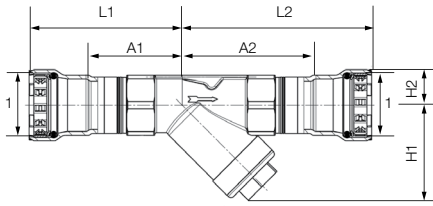
**Viega MegaPress 316 Strainer Valve - Model 5981.1**

Part No.	Size (in)	H1 (in)		H2 (in)		L1 (in)		L2 (in)		A1 (in)		A2 (in)		Cv (US gal/min)
		Dec	Frac	Dec	Frac	Dec	Frac	Dec	Frac	Dec	Frac	Dec	Frac	
87140	1/2	1.69	11 <sup>1</sup> / <sub>16</sub>	0.63	5/8	2.87	2 <sup>7</sup> / <sub>8</sub>	3.50	3 <sup>1</sup> / <sub>2</sub>	1.81	1 <sup>13</sup> / <sub>16</sub>	2.44	2 <sup>7</sup> / <sub>16</sub>	3.7
87145	3/4	2.01	2	0.75	3/4	3.19	3 <sup>3</sup> / <sub>16</sub>	3.98	4	2.05	2 <sup>1</sup> / <sub>16</sub>	2.83	2 <sup>13</sup> / <sub>16</sub>	6.2
87150	1	2.52	2 <sup>1</sup> / <sub>2</sub>	0.91	15 <sup>1</sup> / <sub>16</sub>	3.50	3 <sup>1</sup> / <sub>2</sub>	4.72	4 <sup>3</sup> / <sub>4</sub>	2.17	2 <sup>3</sup> / <sub>16</sub>	3.39	3 <sup>3</sup> / <sub>8</sub>	8.3
87155	1 <sup>1</sup> / <sub>4</sub>	2.76	2 <sup>3</sup> / <sub>4</sub>	1.10	1 <sup>1</sup> / <sub>8</sub>	4.13	4 <sup>1</sup> / <sub>8</sub>	5.51	5 <sup>1</sup> / <sub>2</sub>	2.28	2 <sup>1</sup> / <sub>4</sub>	3.66	3 <sup>11</sup> / <sub>16</sub>	14.6
87160	1 <sup>1</sup> / <sub>2</sub>	3.19	3 <sup>3</sup> / <sub>16</sub>	1.22	1 <sup>1</sup> / <sub>4</sub>	4.25	4 <sup>1</sup> / <sub>4</sub>	5.83	5 <sup>13</sup> / <sub>16</sub>	2.36	2 <sup>3</sup> / <sub>8</sub>	3.98	4	21.4
87165	2	3.54	3 <sup>9</sup> / <sub>16</sub>	1.46	1 <sup>7</sup> / <sub>16</sub>	4.57	4 <sup>9</sup> / <sub>16</sub>	6.61	6 <sup>5</sup> / <sub>8</sub>	2.60	2 <sup>5</sup> / <sub>8</sub>	4.61	4 <sup>5</sup> / <sub>8</sub>	33.4

## 5 Limited Warranty

### Viega Metal Systems for Industrial Applications

**Industrial applications are defined as non-residential and non-commercial applications not normally accessible to the general public, including manufacturing, mining, process or fabrication environments.**

Subject to the terms and conditions of this Limited Warranty, Viega LLC (Viega) warrants to end users, installers and distribution houses that its Viega metal press products (Viega product) when properly installed in industrial applications shall be free from failure caused by manufacturing defects for a period of two (2) years from date of installation.

Under this Limited Warranty, you only have a right to a remedy if the failure or leak resulted from a manufacturing defect in the Viega product and the failure or leak occurs during the warranty period. You do not have a remedy under this warranty and the warranty remedy does not apply if the failure or any resulting damage is caused by (1) components other than those sold by Viega; (2) not designing, installing, inspecting, testing, or maintaining the Viega product in accordance with Viega's installation and product instructions in effect at the time of installation and other specifications and approvals applicable to the installation; (3) improper handling and protection of the Viega product prior to, during and after installation, inadequate freeze protection, or exposure to environmental or operating conditions not recommended for the application; or (4) acts of nature, such as, but not limited to earthquakes, fire, or weather damage. Final approval as to use compatibility to a specific process or fluid application is the responsibility of the engineer of record or responsible design/facilities personnel and this Limited Warranty only applies to manufacturing defects in the Viega Product.

In the event of a leak or other failure in the Viega product covered by this warranty, it is the responsibility of the end user to take appropriate measures to diminish any damage, to include making timely repairs. Only if the warranty applies will Viega be responsible for the remedy under this warranty. The part or parts which you claim failed should be kept and Viega contacted by writing to the address below or telephoning 1-800-976-9819 within

thirty (30) calendar days after the leak or other failure and identifying yourself as having a warranty claim. You should be prepared to ship, at your expense, the product which you claim failed due to a manufacturing defect, document the date of installation, and the amount of the repair or replacement if performed by you. Within a reasonable time after receiving the product, Viega will investigate the reasons for the failure, which includes the right to inspect the product at a Viega location and reasonable access to the site of damage. Viega will notify you in writing as to the results of its review.

In the event that Viega determines that the failure or leak was the result of a manufacturing defect in the Viega Product covered by this warranty and to which this warranty applies, the EXCLUSIVE AND ONLY REMEDY under this warranty shall be the reimbursement for reasonable charges for repair or replacement of the Viega Product itself. VIEGA SHALL NOT BE LIABLE FOR CONSEQUENTIAL OR OTHER DAMAGE (FOR EXAMPLE, ECONOMIC LOSS, WATER OR PROPERTY OR MOLD REMEDIATION) UNDER ANY LEGAL THEORY AND WHETHER ASSERTED BY DIRECT ACTION, FOR CONTRIBUTION OR INDEMNITY OR OTHERWISE.

THE ABOVE WARRANTY IS IN LIEU OF ALL OTHER WARRANTIES, EXPRESS OR IMPLIED, INCLUDING, BUT NOT LIMITED TO, THE IMPLIED WARRANTIES OR ANY STATUTE OF LIMITATIONS RELATING TO SUCH WARRANTIES. Other than this Limited Warranty, Viega does not authorize any person or firm to create for it any other obligation or liability in connection with its products.

This Limited Warranty gives you specific legal rights and you also may have other rights which may vary from state to state. This warranty shall be interpreted and applied under the law of the state in which the product is installed and is intended as a Commercial Warranty.

 **Viega LLC**  
585 Interlocken Blvd.  
Broomfield, CO 80021

Phone (800) 976-9819  
[www.viega.us](http://www.viega.us)

SM-MP 0425 MegaPress Stainless

