

Dimensional Document

Viega MegaPress® Fittings



This document is subject to updates. For the most current Viega technical literature please visit www.viega.us.



Viega products are designed to be installed by licensed and trained plumbing and mechanical professionals who are familiar with Viega products and their installation. **Installation by non-professionals may void Viega LLC's warranty.**

MegaPress 90° Elbow, Carbon Steel, P x P - Models 4816 / 5916 / 6616

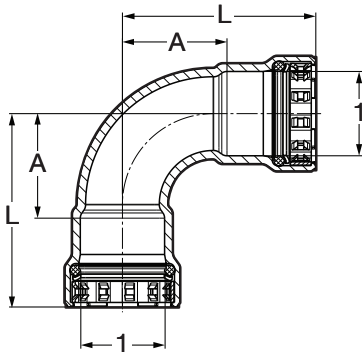

EPDM	Part No.		Size (in)	A (in)	L (in)
	FKM	HNBR			
25200	84305	25201	1/2	1.17	2.24
25205	84310	25206	3/4	1.36	2.52
25210	84315	25211	1	1.72	3.07
25215	84320	25216	1 1/4	2.00	3.82
25220	84325	25221	1 1/2	2.26	4.13
25225	84330	25226	2	2.80	4.78

Viega MegaPress 90° Elbow P x P - Models 4816XL / 6616XL

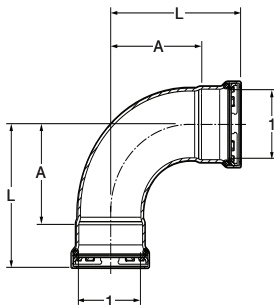

Part No.		Size (in)	A (in)	L (in)
FKM	HNBR			
26500	28600	2 1/2	4.15	5.94
26505	28605	3	4.76	7.09
26510	28610	4	6.00	9.17

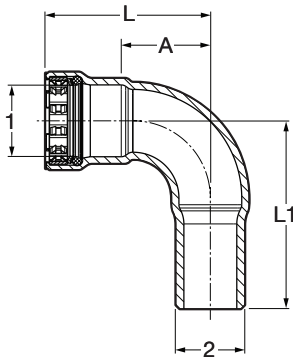
MegaPress 90° Elbow, Carbon Steel, P x FTG - Models 4816.1 / 5916.1 / 6616.1

EPDM	Part No.		Size (in)		A (in)	L (in)	L1 (in)
	FKM	HNBR	1	2			
26050	84875	26051	1/2 x 1/2		1.17	2.24	2.56
26055	84880	26056	3/4 x 3/4		1.36	2.52	2.87
26060	84885	26061	1 x 1		1.72	3.07	3.39
26065	84890	26066	1 1/4 x 1 1/4		2.00	3.82	4.04
26070	84895	26071	1 1/2 x 1 1/2		2.26	4.13	4.21
26075	84900	26076	2 x 2		2.80	4.78	5.08

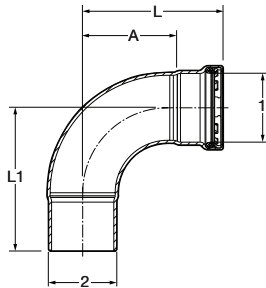
Viega MegaPress 90° Street Elbow P x FTG - Models 4816.1XL / 6616.1XL

FKM	Part No.		Size (in)		A (in)	L (in)	L1 (in)
	HNBR	1	2				
26515	28615	2 1/2 x 2 1/2			4.15	5.94	6.06
26520	28620	3 x 3			4.76	7.09	6.81
26525	28625	4 x 4			6.00	9.17	8.78

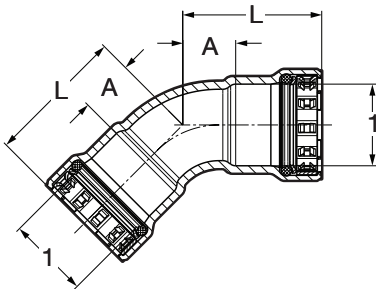
MegaPress 45° Elbow, Carbon Steel, P x P - Models 4826 / 5926 / 6626

EPDM	Part No.		Size (in)		A (in)	L (in)
	FKM	HNBR	1	2		
25230	84335	25231	1/2		0.60	1.67
25235	84340	25236	3/4		0.71	1.87
25240	84345	25241	1		0.86	2.20
25245	84350	25246	1 1/4		0.98	2.80
25250	84355	25251	1 1/2		1.12	2.99
25255	84360	25256	2		1.32	3.31

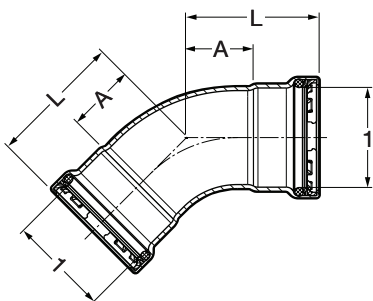
Viega MegaPress 45° Elbow P x P - Models 4826XL / 6626XL

FKM	Part No.		Size (in)		A (in)	L (in)
	HNBR	1	2			
26530	28630	2 1/2			2.10	3.90
26535	28635	3			2.26	4.56
26540	28640	4			2.74	5.92

MegaPress 45° Elbow, Carbon Steel, P x FTG - Models 4826.1 / 5926.1 / 6626.1

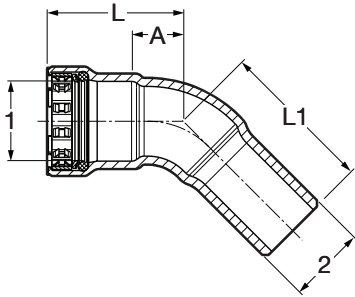

EPDM	Part No.		Size (in)		A (in)	L (in)	L1 (in)
	FKM	HNBR	1	2			
26100	84905	26101	1/2	1/2	0.60	1.67	1.97
26105	84910	26106	3/4	3/4	0.71	1.87	2.13
26110	84915	26111	1	1	0.86	2.20	2.52
26115	84920	26116	1 1/4	1 1/4	0.98	2.80	2.99
26120	84925	26121	1 1/2	1 1/2	1.12	2.99	3.07
26125	84930	26126	2	2	1.32	3.31	3.58

Viega MegaPress 45° Street Elbow P x FTG - Models 4826.1XL / 6626.1XL

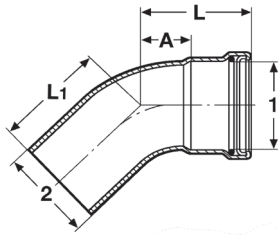

FKM	Part No.		Size (in)		A (in)	L (in)	L1 (in)
	HNBR	1	2				
26545	28645	26545	2 1/2	2 1/2	2.10	3.90	3.95
26550	28650	26550	3	3	2.26	4.56	4.34
26555	28655	26555	4	4	2.74	5.92	5.62

MegaPress Tee, Carbon Steel, P x P x P - Models 4818 / 5918 / 6618

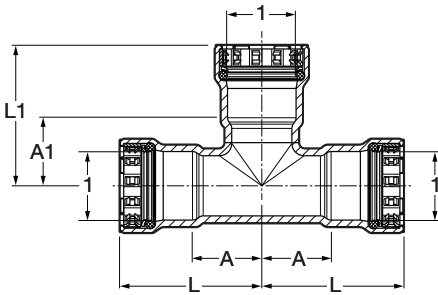

EPDM	Part No.		Size (in)		A (in)	A1 (in)	L (in)	L1 (in)
	FKM	HNBR	1	2				
25300	84365	25301	1/2	1/2	0.97	0.93	2.04	2.00
25305	84370	25306	3/4	3/4	1.11	1.09	2.26	2.24
25310	84375	25311	1	1	1.23	1.23	2.57	2.57
25315	84395	25316	1 1/4	1 1/4	1.41	1.38	3.23	3.20
25320	84400	25321	1 1/2	1 1/2	1.57	1.54	3.44	3.41
25325	84405	25326	2	2	1.81	1.80	3.80	3.79

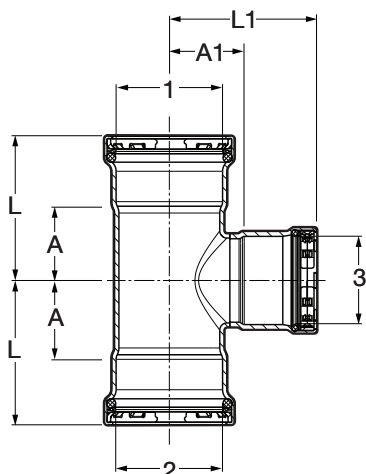
Viega MegaPress Tee P x P x P - Models 4818XL / 6618XL

Part No.		Size (in)			A (in)	A1 (in)	L (in)	L1 (in)
FKM	HNBR	1	2	3				
NA	28910	2½	2½	1	1.35	2.04	3.15	3.38
NA	28905	2½	2½	1¼	1.72	2.06	3.52	3.87
26575	28675	2½	2½	1½	1.72	2.08	3.52	3.95
26580	28680	2½	2½	2	2.16	2.05	3.96	4.04
26560	28660	2½	2½	2½	2.16	2.26	3.96	4.06
26595	28695	3	3	1¼	1.70	2.31	4.04	4.13
26590	28690	3	3	1½	1.80	2.33	4.13	4.20
26585	28685	3	3	2	2.11	2.30	4.41	4.29
26600	28700	3	3	2½	2.32	2.51	4.63	4.31
26565	28665	3	3	3	2.55	2.52	4.88	4.82
26605	28705	4	4	1½	1.86	2.90	5.04	4.77
26610	28710	4	4	2	2.18	2.87	5.35	4.86
26615	28715	4	4	2½	2.40	3.08	5.55	4.88
26620	28720	4	4	3	2.66	3.13	5.81	5.43
26570	28670	4	4	4	3.22	3.08	6.40	6.26

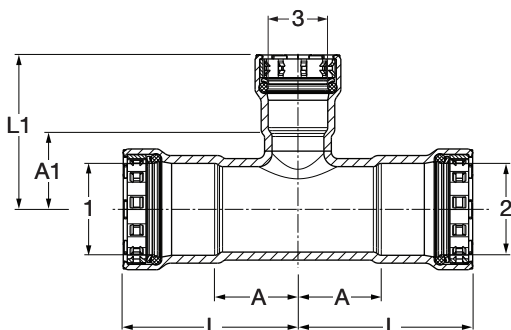
MegaPress Reducing Tee, Carbon Steel, P x P x P - Models 4818 / 5918 / 6618

EPDM	Part No.		Size (in)			A (in)	A1 (in)	L (in)	L1 (in)
	FKM	HNBR	1	2	3				
25330	84410	25331	¾	¾	½	1.11	1.07	2.26	2.14
25335	84415	25336	1	1	½	1.23	1.20	2.57	2.28
25340	84420	25341	1	1	¾	1.23	1.24	2.57	2.40
25510	84380	25491	1¼	1¼	½	1.41	1.35	3.23	2.42
25515	84385	25496	1¼	1¼	¾	1.41	1.39	3.23	2.55
25350	84390	25351	1¼	1¼	1	1.41	1.38	3.23	2.73
25360	84425	25361	1½	1½	½	1.57	1.44	3.44	2.51
25365	84430	25366	1½	1½	¾	1.57	1.48	3.44	2.64
25370	84435	25371	1½	1½	1	1.57	1.48	3.44	2.83
25375	84440	25376	1½	1½	1¼	1.57	1.50	3.44	3.32
25380	84445	25381	2	2	½	1.81	1.74	3.80	2.81
25385	84450	25386	2	2	¾	1.81	1.80	3.80	2.95
25390	84455	25391	2	2	1	1.81	1.75	3.80	3.10
25395	84460	25396	2	2	1¼	1.81	1.78	3.80	3.60
25400	84465	25401	2	2	1½	1.81	1.84	3.80	3.71

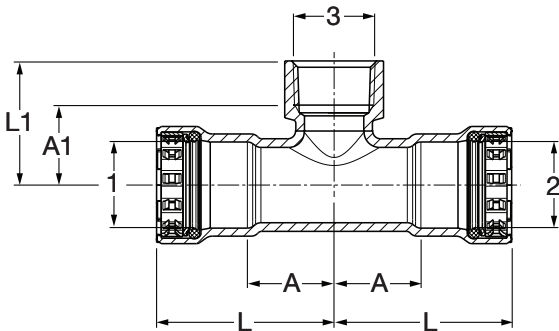
MegaPress Reducing Tee, Carbon Steel, P x P x FPT - Models 4817.2 / 5917.2 / 6617.2

EPDM	Part No.		Size (in)			A (in)	A1 (in)	L (in)	L1 (in)
	FKM	HNBR	1	2	3				
25405	84545	25406	¾	¾	½	1.11	1.02	2.26	1.55
25480	84550	25481	¾	¾	¾	1.11	1.03	2.26	1.58
25410	84555	25411	1	1	½	1.23	1.19	2.57	1.73
25415	84560	25416	1	1	¾	1.23	1.18	2.57	1.73
25485	84575	25486	1¼	1¼	½	1.41	1.31	3.23	1.85
25505	84570	25506	1¼	1¼	¾	1.41	1.33	3.23	1.89
25500	84565	25501	1¼	1¼	1	1.41	1.37	3.23	2.03
25435	84580	25436	1½	1½	½	1.57	1.42	3.44	1.95
25440	84585	25441	1½	1½	¾	1.57	1.41	3.44	1.97
25445	84590	25446	1½	1½	1	1.57	1.57	3.44	2.24
25450	NA	25451	1½	1½	1¼	1.57	1.47	3.44	2.15
25455	84595	25456	2	2	½	1.81	1.70	3.80	2.24
25460	84600	25461	2	2	¾	1.81	1.72	3.80	2.28
25465	84605	25466	2	2	1	1.81	1.89	3.80	2.55
25470	NA	25471	2	2	1¼	1.81	1.77	3.80	2.45
25475	NA	25476	2	2	1½	1.81	1.73	3.80	2.41

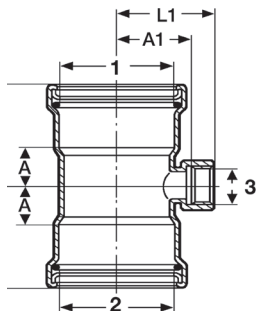
Viega MegaPress Tee P x P x FPT - Models 4817.2XL / 6617.2XL

Part No.		Size (in)			A (in)	A1 (in)	L (in)	L1 (in)
FKM	HNBR	1	2	3				
26625	28725	2½	2½	¾	1.35	2.00	3.15	2.55
26630	28730	3	3	¾	1.44	2.24	3.74	2.80
26635	28735	4	4	¾	1.55	2.76	4.72	3.31

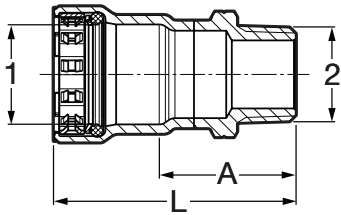
MegaPress Adapter, Carbon Steel, P x MPT - Models 4811 / 5911 / 6611

EPDM	Part No.		Size (in)		A (in)	L (in)
	FKM	HNBR	1	2		
25100	84245	25101	1/2	1/2	1.45	2.52
25105	84250	25106	3/4	3/4	1.50	2.66
25110	84255	25111	1	1	1.66	3.00
25115	84260	25116	1 1/4	1 1/4	1.90	3.70
25120	84265	25121	1 1/2	1 1/2	1.93	3.80
25125	84270	25126	2	2	1.93	3.92

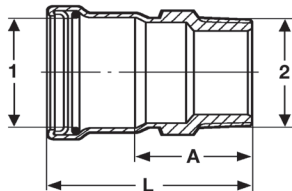
Viega MegaPress Adapter P x MPT - Models 4811XL / 6611XL

FKM	Part No.		Size (in)		A (in)	L (in)
	HNBR		1	2		
26640	28740		2 1/2	2 1/2	2.75	4.55
26645	28745		3	3	2.89	5.20
26650	28750		4	4	3.03	6.21

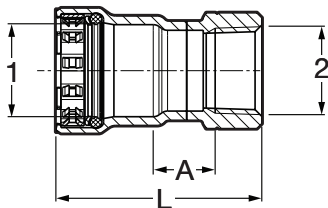
MegaPress Adapter, Carbon Steel, P x FPT - Models 4812 / 5912 / 6612

EPDM	Part No.		Size (in)		A (in)	L (in)
	FKM	HNBR	1	2		
25130	84275	25131	1/2	1/2	0.69	2.29
25135	84280	25136	3/4	3/4	0.74	2.45
25140	84285	25141	1	1	0.73	2.74
25145	84290	25146	1 1/4	1 1/4	0.77	3.27
25150	84295	25151	1 1/2	1 1/2	0.72	3.28
25155	84300	25156	2	2	0.76	3.44

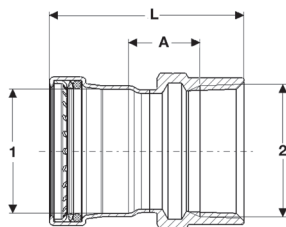
Viega MegaPress Adapter P x FPT - Models 4812XL / 6612XL

FKM	Part No.		Size (in)		A (in)	L (in)
	HNBR		1	2		
26655	28755		2 1/2	2 1/2	1.13	3.86
26660	28760		3	3	1.17	4.49
26665	28765		4	4	1.15	5.42

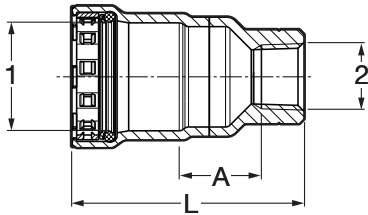
MegaPress Reducing Adapter, Carbon Steel, P x FPT - Models 4812 / 5912 / 6612

EPDM	Part No.		Size (in)		A (in)	L (in)
	FKM	HNBR	1	2		
25575	84750	25576	¾ x ½		0.73	2.43
25580	84755	25581	1 x ½		1.03	2.91
25585	84760	25586	1 x ¾		0.78	2.68
25590	84765	25591	1¼ x ½		1.15	3.50
25595	84770	25596	1¼ x ¾		1.11	3.48
25600	84775	25601	1¼ x 1		0.76	3.24
25605	84780	25606	1½ x ½		1.31	3.72
25610	84785	25611	1½ x ¾		1.27	3.70
25615	84790	25616	1½ x 1		1.11	3.64
25620	84795	25621	1½ x 1¼		0.86	3.41
25625	NA	25626	2 x ½		1.56	4.06
25630	84800	25631	2 x ¾		1.54	4.08
25635	84805	25636	2 x 1		1.35	4.00
25640	NA	25641	2 x 1¼		1.28	3.93
25645	84810	25646	2 x 1½		1.03	3.70

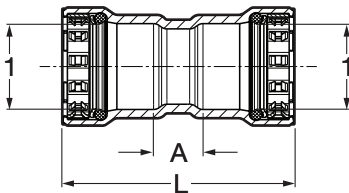
MegaPress Coupling with Stop, Carbon Steel, P x P - Models 4815 / 5915 / 6615

EPDM	Part No.		Size (in)		A (in)	L (in)
	FKM	HNBR	1			
25000	84215	25001	½		0.56	2.70
22005	84220	22009	¾		0.63	2.94
25010	84225	25011	1		0.59	3.29
25015	84230	25016	1¼		0.70	4.34
25020	84235	25021	1½		0.89	4.63
25025	84240	25026	2		0.77	4.75

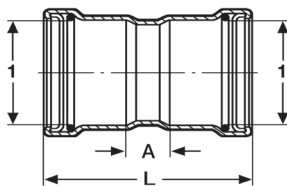
Viega MegaPress Coupling with Stop P x P - Models 4815XL / 6615XL

Part No.		Size (in)		A (in)	L (in)
FKM	HNBR	1			
26670	28770	2½		1.32	4.92
26675	28775	3		1.38	5.98
26680	28780	4		1.57	7.87

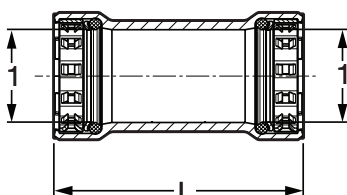
MegaPress Coupling No Stop, Carbon Steel, P x P - Models 4815.5 / 5915.5 / 6615.5

EPDM	Part No.		Size (in)		L (in)
	FKM	HNBR	1		
25030	84130	25031	½		2.71
25035	84135	25036	¾		2.94
25040	84140	25041	1		3.29
25045	84145	25046	1¼		4.34
25050	84150	25051	1½		4.63
25055	84155	25056	2		4.74

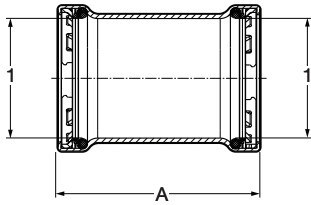
Viega MegaPress Coupling No Stop P x P - Models 4815.5XL / 6615.5XL

Part No.		Size (in)	L (in)
FKM	HNBR	1	
26685	28785	2½	4.92
26690	28790	3	5.98
26695	28795	4	7.91

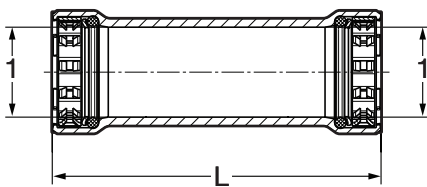
MegaPress Extended No Stop Coupling, Carbon Steel, P x P - Models 4815.3 / 6615.3

Part No.		Size (in)	L (in)
EPDM	HNBR	1	
25070	25071	½	3.82
25075	25076	¾	4.00
25080	25081	1	4.38
25085	25086	1¼	5.33
25090	25091	1½	5.44
25095	25096	2	5.63

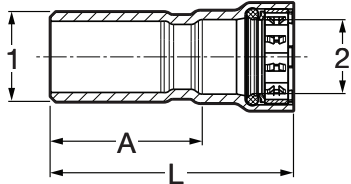
MegaPress Reducer, Carbon Steel, FTG x P - Models 4815.1 / 5915.1 / 6615.1

EPDM	Part No.		Size (in)	A (in)	L (in)
	FKM	HNBR	1 2		
26000	84160	26001	¾ x ½	1.78	2.85
26005	84165	26006	1 x ½	2.14	3.21
26010	84170	26011	1 x ¾	2.09	3.24
NA	84175	NA	1¼ x ¾	2.81	3.97
26015	84180	26016	1¼ x 1	2.63	3.98
26020	84185	26021	1½ x ¾	2.98	4.13
26025	84190	26031	1½ x 1	2.81	4.16
26030	84195	26026	1½ x 1¼	2.70	4.52
26035	84200	26036	2 x 1	3.14	4.49
26040	84205	26041	2 x 1¼	3.02	4.83
26045	84210	26046	2 x 1½	2.96	4.83

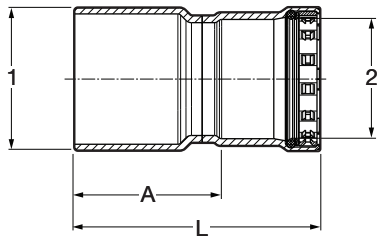
Viega MegaPress Reducer FTG x P - Models 4815.1XL / 6615.1XL

Part No.		Size (in)		A (in)	L (in)
FKM	HNBR	1	2		
26700	28800	2½	x 1	3.49	4.83
26705	28805	2½	x 1¼	3.37	5.19
26710	28810	2½	x 1½	3.30	5.17
26715	28815	2½	x 2	2.97	4.96
26720	28820	3	x 1¼	4.16	5.98
26725	28825	3	x 1½	4.08	5.95
26730	28830	3	x 2	3.76	5.75
26735	28835	3	x 2½	3.75	5.55
26740	28840	4	x 1½	5.60	7.47
26745	28845	4	x 2	5.28	7.27
26750	28850	4	x 2½	5.27	7.06
26755	28855	4	x 3	5.03	7.33

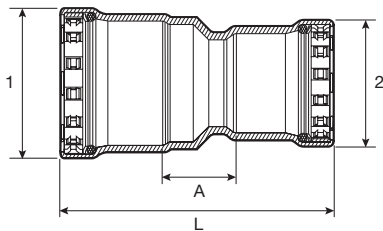
MegaPress Reducer, Carbon Steel, P x P - Models 4815.2 / 6615.2

Part No.		Size (in)		A (in)	L (in)
EPDM	HNBR	1	2		
25930	25931	¾	x ½	1.20	3.43
25935	25936	1	x ½	1.37	3.79
25940	25941	1	x ¾	1.24	3.74
25945	25946	1¼	x ¾	1.40	4.37
25950	25951	1¼	x 1	1.23	4.39
25955	25956	1½	x 1¼	1.21	4.90
25960	25961	2	x 1¼	1.45	5.27
25965	25966	2	x 1½	1.43	5.26

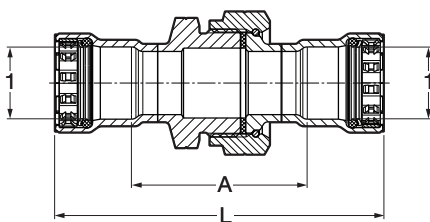
MegaPress Union, Carbon Steel, P x P - Model 4860 / 5960

Part No.		Size (in)	A (in)	L (in)
EPDM	FKM	1		
25700	84815	½	2.35	4.50
25705	84820	¾	2.67	4.99
25710	84825	1	2.65	5.34
25715	84830	1¼	2.84	6.48
25720	84835	1½	2.89	6.63
25725	84840	2	3.92	7.89

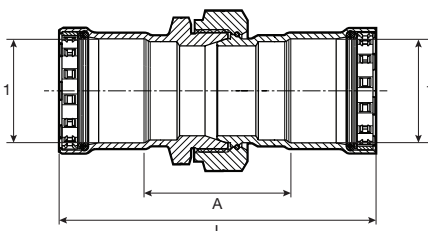
MegaPress Union, Carbon Steel, P x P - Model 6660

Part No.	Size (in)	A (in)	L (in)
HNBR	1		
25701	½	2.33	4.47
25706	¾	2.67	4.98
25711	1	2.60	5.29
25716	1¼	2.85	6.49
25721	1½	2.90	6.64
25726	2	3.41	7.35

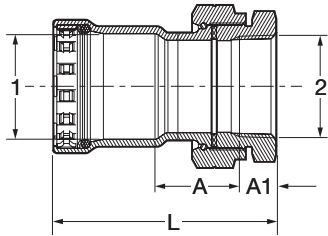
MegaPress Union, Carbon Steel, P x FPT - Model 4862

Part No. EPDM	Size (in)		A (in)	A1 (in)	L (in)
	1	2			
25650	½ x ½		1.25	0.54	2.85
25655	¾ x ¾		1.48	0.56	3.20
25660	1 x 1		1.37	0.66	3.38
25665	1¼ x 1¼		1.53	0.68	4.03
25670	1½ x 1½		1.55	0.68	4.10
25675	2 x 2		2.33	0.70	5.00

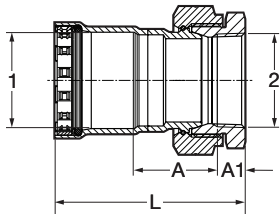
MegaPress Union, Carbon Steel, P x FPT - Model 6662

Part No. HNBR	Size (in)		A (in)	A1 (in)	L (in)
	1	2			
25651	½ x ½		1.38	0.54	2.98
25656	¾ x ¾		1.64	0.56	3.35
25661	1 x 1		1.62	0.66	3.63
25666	1¼ x 1¼		1.85	0.68	4.35
25671	1½ x 1½		1.80	0.68	4.35
25676	2 x 2		2.11	0.70	4.77

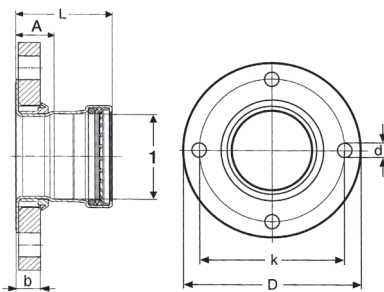
Viega MegaPress Adapter Flange P - Models 4859XL / 6659XL

Part No. FKM HNBR	Size (in) 1	A (in)	L (in)	b (in)	k (in)	D (in)	d (in)	
								26775
26780	28880	3	1.65	3.95	0.96	5.98	7.48	0.75

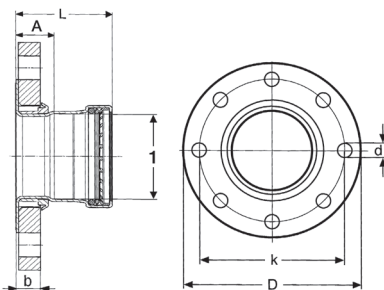
Viega MegaPress Adapter Flange P - Models 4859XL / 6659XL

Part No. FKM HNBR	Size (in) 1	A (in)	L (in)	b (in)	k (in)	D (in)	d (in)	
								26785

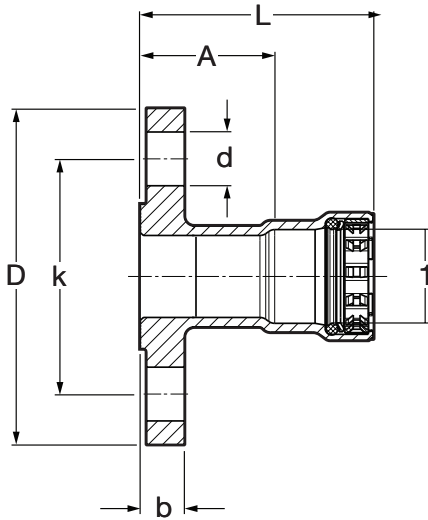
MegaPress Flange, Carbon Steel, P x BP - Models 4859.5 / 5959.5 / 6659.5

Part No.			Size (in)	A (in)	L (in)	b (in)	k (in)	D (in)	d (in)
EPDM	FKM	HNBR	1						
25760	84845	25761	1/2	1.51	2.58	0.46	2.36	3.54	0.63
25765	84850	25766	3/4	1.58	2.74	0.52	2.76	3.94	0.63
25770	84855	25771	1	1.75	3.10	0.58	3.11	4.33	0.63
25775	84860	25776	1 1/4	1.89	3.71	0.64	3.50	4.53	0.63
25780	84865	25781	1 1/2	2.06	3.93	0.70	3.86	4.92	0.63
25785	84870	25786	2	2.07	4.06	0.77	4.76	5.91	0.75

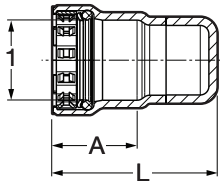
MegaPress Cap, Carbon Steel, P x Cap - Models 4856 / 5956 / 6656

Part No.			Size (in)	A (in)	L (in)
EPDM	FKM	HNBR	1		
25730	84100	25731	1/2	1.07	2.14
25735	84105	25736	3/4	1.16	2.26
25740	84110	25741	1	1.35	2.43
25745	84115	25746	1 1/4	1.82	2.93
25750	84120	25751	1 1/2	1.87	3.02
25755	84125	25756	2	1.99	3.11

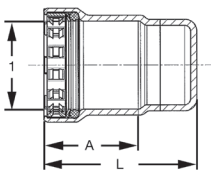
Viega MegaPress Cap P - Models 4856.1XL / 6656.1XL

Part No.		Size (in)	A (in)	L (in)
FKM	HNBR	1		
26760	28860	2 1/2	1.80	3.27
26765	28865	3	2.30	3.78
26770	28870	4	3.18	4.65

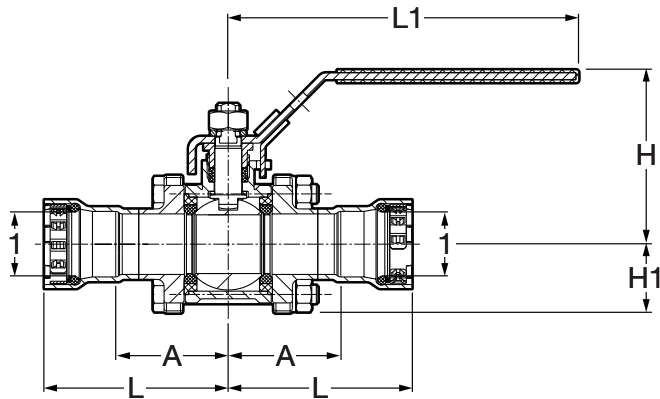
MegaPress 3-Piece Ball Valve, Carbon Steel, P x P - Models 4875.8 / 5975.8 / 5975.8XL

Part No.		Size (in)*	A (in)	L (in)	L1 (in)	H (in)	H1 (in)
EPDM	FKM	1					
28500	86400	1/2	1.72	2.80	5.88	2.85	1.04
28501	86405	3/4	1.91	3.06	5.88	2.93	1.16
28502	86410	1	2.19	3.54	7.54	3.33	1.40
28503	86415	1 1/4	2.50	4.31	7.54	3.57	1.57
28504	86420	1 1/2	2.92	4.79	7.54	3.89	1.83
28505	86425	2	3.09	5.07	7.54	3.89	1.83
NA	86680	2 1/2	3.74	5.54	11.06	5.08	2.28
NA	86685	3	4.37	6.67	11.06	5.47	2.68
NA	86690	4	4.88	8.06	13.07	6.89	3.79

Sizes up to 3" have 4 bolt flanges; 4" has 6 bolt flanges.

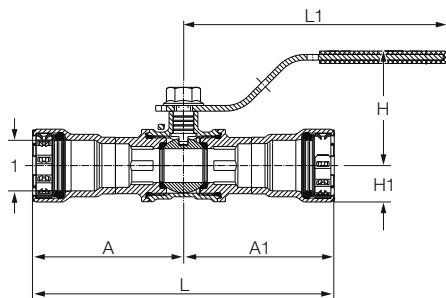
Viega MegaPressG Ball Valve - Model 6675

Part No.	Size (in)	A (in)	A1 (in)	L (in)	L1 (in)	H (in)	H1 (in)
HNBR	1						
30600	1/2	2.62	2.62	5.24	4.57	1.99	0.63
30605	3/4	2.80	2.80	5.59	4.57	2.10	0.77
30610	1	3.16	3.16	6.31	5.77	2.46	0.91
30615	1 1/4	3.78	3.78	7.55	5.77	2.69	1.14
30620	1 1/2	3.98	3.98	7.97	6.12	3.02	1.36
30625	2	4.35	4.35	8.70	6.12	3.31	1.65

Viega MegaPressG Ball Valve - Model 6675.1

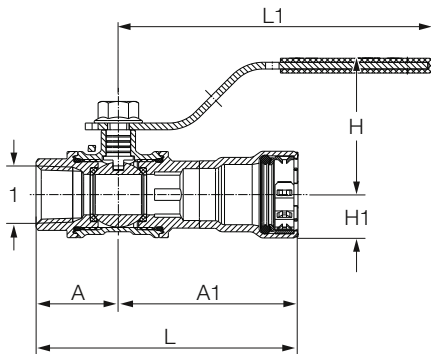

Part No. HNBR	Size (in)	A (in)	A1 (in)	L (in)	L1 (in)	H (in)	H1 (in)
	1						
30630	1/2	1.20	2.62	3.82	4.57	1.99	0.63
30635	3/4	1.36	2.80	4.15	4.57	2.10	0.77
30640	1	1.85	3.16	5.00	5.77	2.46	0.91
30645	1 1/4	1.87	3.78	5.64	5.77	2.69	1.14
30650	1 1/2	2.05	3.98	6.03	6.12	3.02	1.36
30655	2	2.43	4.35	6.78	6.12	3.31	1.65

Viega MegaPressG Ball Valve - Model 6675.2

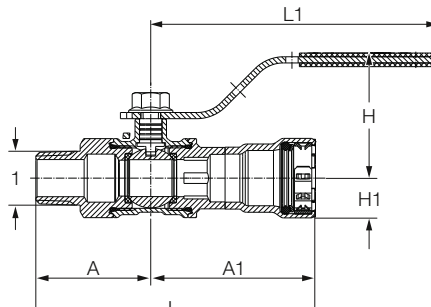

Part No. HNBR	Size (in)	A (in)	A1 (in)	L (in)	L1 (in)	H (in)	H1 (in)
	1						
30660	1/2	1.81	2.62	4.44	4.57	0.63	1.99
30665	3/4	1.87	2.80	4.64	4.57	0.77	2.10
30670	1	2.53	3.16	5.69	5.77	0.91	2.46
30675	1 1/4	2.56	3.78	6.33	5.77	1.14	2.69
30680	1 1/2	2.67	3.98	6.65	6.12	1.36	3.02
30685	2	2.92	4.35	7.28	6.12	1.65	3.31

Viega MegaPressG Ball Valve - Model 6675.3

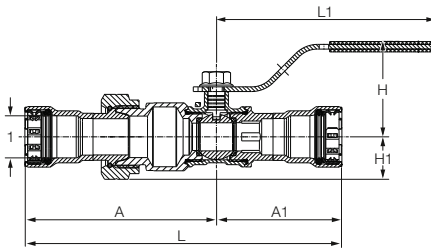

Part No. HNBR	Size (in)	A (in)	A1 (in)	L (in)	L1 (in)	H (in)	H1 (in)
	1						
30690	1/2	4.00	2.62	6.62	4.57	1.99	0.89
30695	3/4	4.19	2.80	6.99	4.57	2.10	1.08
30700	1	4.53	3.16	7.69	5.77	2.46	1.18
30705	1 1/4	5.65	3.78	9.43	5.77	2.69	1.50
30710	1 1/2	5.59	3.98	9.57	6.12	3.02	1.50
30715	2	6.53	4.35	10.88	6.12	3.31	1.65

V Viega LLC
585 Interlocken Blvd.
Broomfield, CO 80021

Phone (800) 976-9819
www.viega.us

DD-MP 0821 MegaPress Fittings

