



Manual
Patent Pending

Pneumatic
Patent Pending

Hydraulic
Patent Pending

1.0 PRODUCT DESCRIPTION

Available Sizes

- 3 – 12"/DN80 – DN300

Maximum Working Pressure

- Rated from full vacuum (29" of Hg/33.4 kPa) to 150psi/1035 kPa/10 bar for unidirectional services

Application

- Designed for fluid lines containing solids and abrasive material
- Intended for use in on-off service (no throttling)
- Offers shutoff isolation without expelling media from the bottom of the valve
- Knife, seat and packing can be replaced without removing valve from pipeline
- Features a unidirectional polyurethane seat
- Lower housing includes a flush port for cleaning out the valve during maintenance

Actuation Options

- Hand wheel (3 – 8"/DN80 – DN200)
- Bevel gear (10 – 12"/DN250 – DN300)
- Pneumatic cylinder
- Hydraulic cylinder
- Multi-turn electric actuator

Pipe Materials

- Joins OGS Grooved Carbon Steel and Stainless Steel pipe

ALWAYS REFER TO ANY NOTIFICATIONS AT THE END OF THIS DOCUMENT REGARDING PRODUCT INSTALLATION, MAINTENANCE OR SUPPORT.

1.0 PRODUCT DESCRIPTION (CONTINUED)

Codes and Requirements

- Valve meets the zero-leakage performance standard for ANSI FCI 70-2 Leakage Class IV, MSS-SP61, and API 598
-

2.0 CERTIFICATION/LISTINGS



Product designed and manufactured under Victaulic's Quality Management System, as certified by LPCB in accordance with ISO -9001:2008.

3.0 SPECIFICATIONS – MATERIAL

Body/Coupling: Ductile Iron conforming to ASTM A536, Grade 65-45-12

Body coating: Electroless Nickel – Abrasion and corrosion resistance

Seat: Polyurethane

Retaining plate:

For sizes 3 – 4"/80 – 100mm AISI 1045 Carbon Steel – Black Alkyd Enamel Coating

For sizes 6 – 12"/150 – 300mm Ductile Iron conforming to ASTM A536, Grade 65-45-12 - Black Alkyd Enamel Coating

Knife seal: Polyurethane

Pipe gaskets/Seat gaskets: (specify choice¹)

Grade "E" EPDM

EPDM (Green color code). NOT COMPATIBLE FOR PETROLEUM SERVICES. -30°F to +150°F/-34°C to +66°C.

Grade "T" Lubricated Nitrile

Nitrile (Orange color code). NOT RECOMMENDED FOR HOT WATER SERVICES OVER +150°F/+66°C. 0°F to +150°F/18°C to +66°C.

¹ Services listed are General Service Guidelines only. It should be noted that there are services for which these gaskets are not compatible. Reference should always be made to the latest [Victaulic Gasket Selection Guide](#) for specific gasket service guidelines and for a listing of services which are not compatible.

Packing gland: Ductile Iron conforming to ASTM A536, Grade 65-45-12 – Orange Alkyd Enamel Coating

Knife: UNS S31600 Stainless Steel

Clean-out plug: UNS S41600 Stainless Steel

Gate connector: Ductile Iron conforming to ASTM A536, Grade 65-45-12 – Electroless Nickel Coating

Stem (not shown): UNS S31600 Stainless Steel

Drive nut (not shown): UNS S17400 Stainless Steel

Drive nut Spacer (not shown): UNS S17400 Stainless Steel

Bushing: UNS S17400 Stainless Steel

Yoke: Ductile Iron conforming to ASTM A536, Grade 65-45-12

Alignment dowel pins (not shown): ASME B18.8.2

Handwheel key (not shown): CD Steel, Key Stock

Handwheel (not shown): S235JR Structural Steel – Black Alkyd Enamel Coating

Hardware:

Standard: Carbon Steel Zinc Plated

Optional: Stainless Steel

Stroke limiter: Ductile Iron conforming to ASTM A536 Grade 65-45-12 - Orange Alkyd Enamel Coating

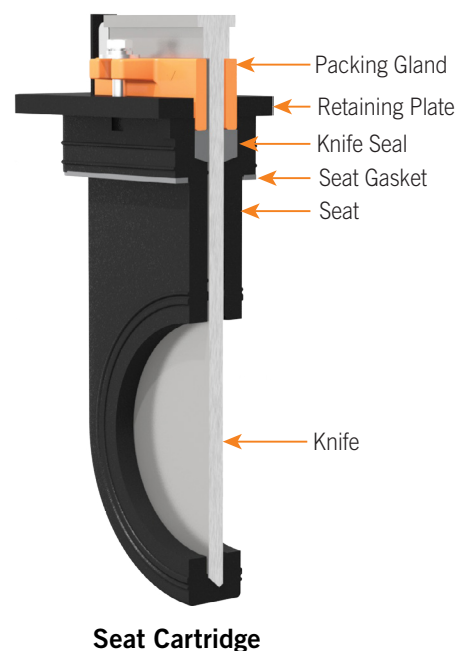
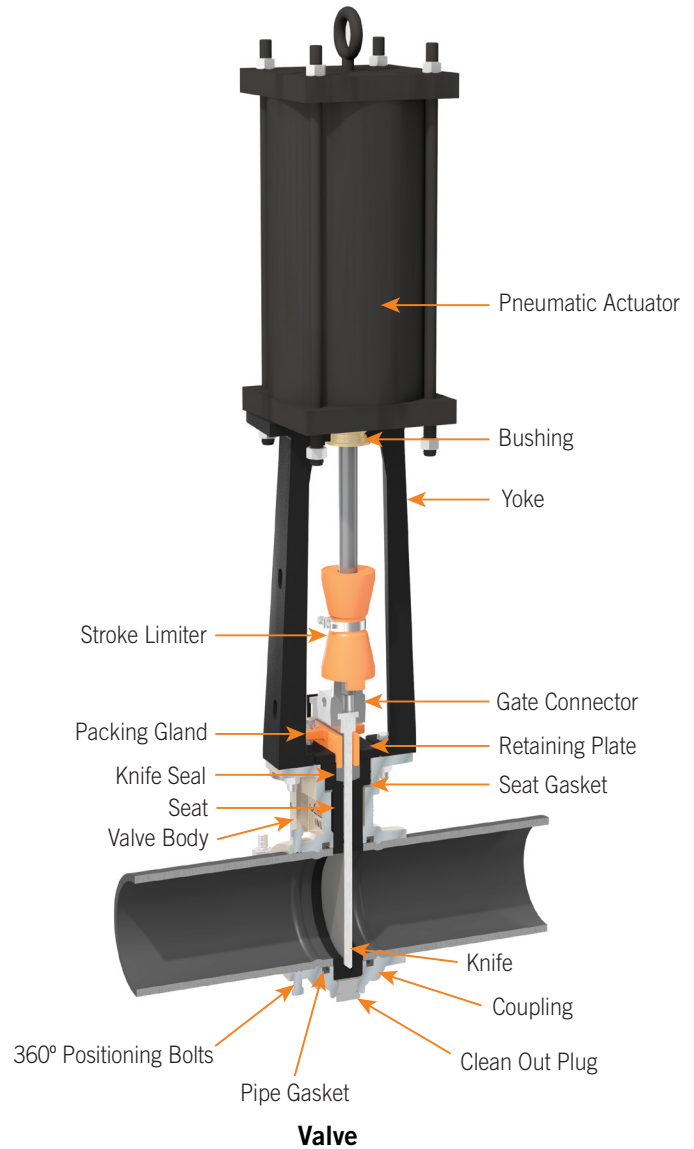

4.0 DIMENSIONS

Manual Handwheel

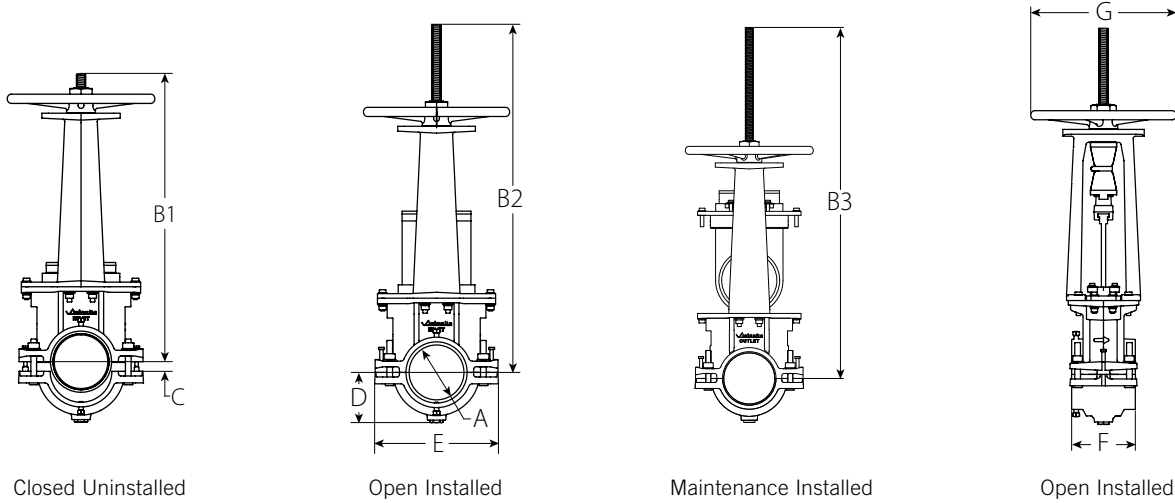

Size		Dimensions									Weight
Nominal	Actual Outside Diameter	A	B1 Closed	B2 Open	B3 Maintenance	C	D	E	F	G	Approx. (Each)
inches DN	inches mm	inches mm	inches mm	inches mm	inches mm	inches mm	inches mm	inches mm	inches mm	inches mm	lb kg
3 DN80	3.500 88.9	3.25 83	24.75 629	28.50 724	33.38 848	0.88 22	3.75 95	10.25 260	6.75 171	16.00 406	113.0 51.3
4 DN100	4.500 114.3	4.00 102	25.50 648	30.25 768	35.25 895	0.88 22	4.50 114	11.25 286	6.75 171	16.00 406	122.0 55.3
6 DN150	6.625 168.3	6.00 152	31.25 794	38.25 972	43.88 1114	1.13 29	5.50 140	13.75 349	7.00 178	16.00 406	166.0 75.3
8 DN200	8.625 219.1	8.00 203	37.50 953	46.50 1181	53.50 1359	1.63 41	6.75 171	15.50 394	7.00 178	16.00 406	237.0 107.5

Manual Bevel Gear

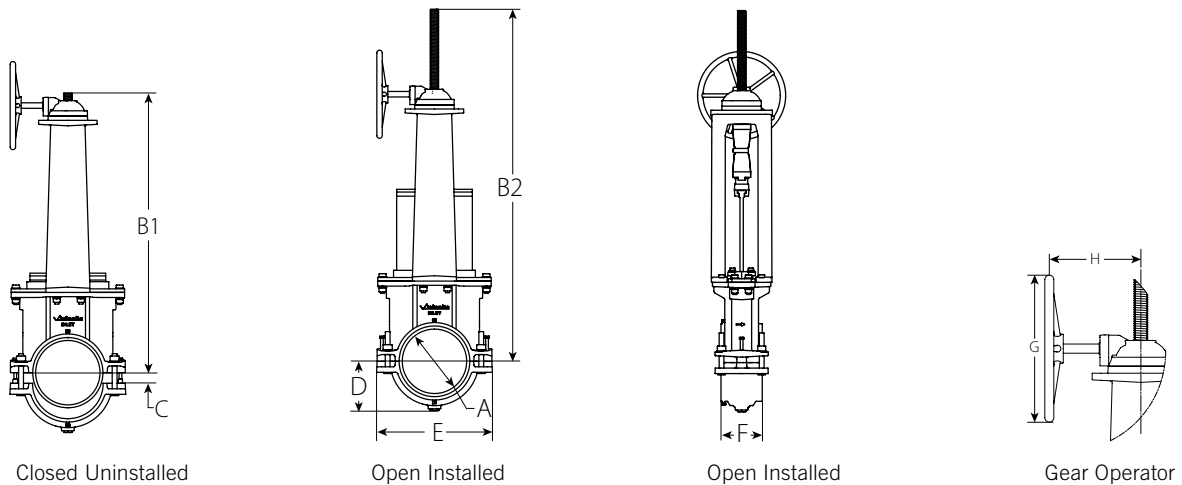

Size		Dimensions									Weight
Nominal	Actual Outside Diameter	A	B1 Closed	B2 Open	C	D	E	F	G	H	Approx. (Each)
inches DN	inches mm	inches mm	inches mm	inches mm	inches mm	inches mm	inches mm	inches mm	inches mm	inches mm	lb kg
10 DN250	10.750 273.0	10.25 260	49.50 1257	60.50 1537	1.75 44	8.00 203	19.00 483	7.50 191	16.00 406	10.50 267	465.0 210.9
12 DN300	12.750 323.9	12.50 318	50.75 1289	64.00 1626	2.00 51	9.00 229	21.00 533	7.50 191	16.00 406	10.50 267	497.0 225.4

4.1 DIMENSIONS

Pneumatic Cylinder

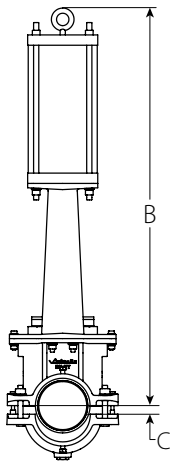

Closed Uninstalled

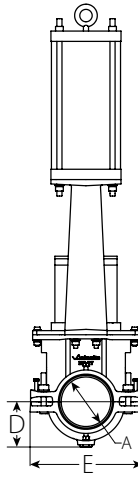

Open Installed

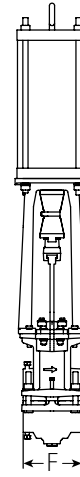

Open Installed

Size		Dimensions						Weight
Nominal	Actual Outside Diameter	A	B	C	D	E	F	Approx. (Each)
inches DN	inches mm	inches mm	inches mm	inches mm	inches mm	inches mm	inches mm	lb kg
3 DN80	3.500 88.9	3.25 83	38.25 972	0.88 22	3.75 95	10.25 260	6.75 171	126.0 57.2
4 DN100	4.500 114.3	4.00 102	40.00 1016	0.88 22	4.50 114	11.25 286	6.75 171	133.0 60.3
6 DN150	6.625 168.3	6.00 152	48.25 1226	1.13 29	5.50 140	13.75 349	7.00 178	215.0 97.5
8 DN200	8.625 219.1	8.00 203	59.00 1499	1.63 41	6.75 171	15.50 394	7.00 178	348.0 157.9
10 DN250	10.750 273.0	10.25 260	71.50 1816	1.75 44	8.00 203	19.00 483	7.50 191	550.0 249.5
12 DN300	12.750 323.9	12.50 318	77.50 1969	2.00 51	9.00 229	21.00 533	7.50 191	586.0 265.8

4.2 DIMENSIONS

Hydraulic Cylinder

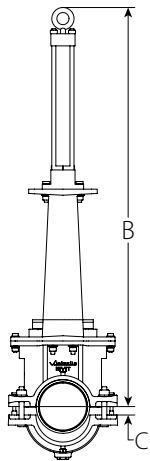

Closed Uninstalled

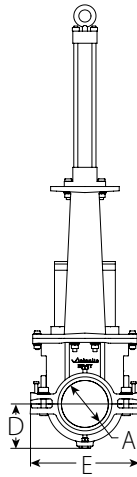

Open Installed

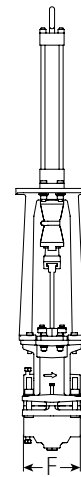

Open Installed

Size		Dimensions						Weight
Nominal	Actual Outside Diameter	A	B	C	D	E	F	Approx. (Each)
inches DN	inches mm	inches mm	inches mm	inches mm	inches mm	inches mm	inches mm	lb kg
3 DN80	3.500 88.9	3.25 83	40.13 1020	0.88 22	3.75 95	10.25 260	6.75 171	115.0 52.2
4 DN100	4.500 114.3	4.00 102	42.00 1067	0.88 22	4.50 114	11.25 286	6.75 171	125.0 56.7
6 DN150	6.625 168.3	6.00 152	49.50 1257	1.13 29	5.50 140	13.75 349	7.00 178	172.0 78.0
8 DN200	8.625 219.1	8.00 203	59.75 1518	1.63 41	6.75 171	15.50 394	7.00 178	259.0 117.5
10 DN250	10.750 273.0	10.25 260	72.25 1835	1.75 44	8.00 203	19.00 483	7.50 191	462.0 209.6
12 DN300	12.750 323.9	12.50 318	80.50 2045	2.00 51	9.00 229	21.00 533	7.50 191	525.0 238.1

4.3 DIMENSIONS

Seat Cartridge

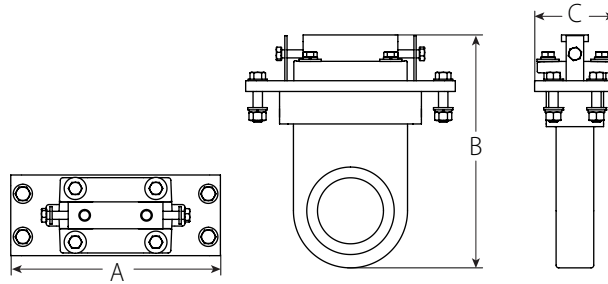

Size inches DN	A inches mm	B inches mm	C inches mm	Approx. Weight (Each) lb kg
3 DN80	9.88 251	10.88 276	3.88 99	16.3 7.4
4 DN100	10.75 273	12.13 308	3.88 99	19.7 8.9
6 DN150	13.00 330	15.00 381	3.88 99	28.9 13.1
8 DN200	15.50 394	18.25 464	3.88 99	40.7 18.4
10 DN250	19.00 483	23.00 584	5.00 127	82.0 37.2
12 DN300	20.63 524	25.50 648	5.00 127	100.6 45.6

4.4 DIMENSIONS

Pipe End Separation

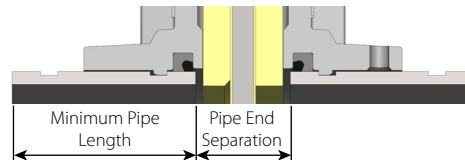

Valve Size inches DN	Maximum "A" Dimension ² inches mm	Nominal Housing Key to Key inches mm	Minimum Pipe End Separation ³ inches mm	Minimum Pipe Length inches mm
3 – 6 DN80 – DN150	0.75 19.1	3.34 84.7	1.88 47.6	4.13 104.9
8 DN200	0.88 22.2	3.64 92.3	1.88 47.6	3.75 95.3
10 – 12 DN250 – DN300	0.88 22.2	4.01 101.8	2.25 57.2	5.00 127.0

² OGS A Dimension plus 0.125" of rubber lining

³ Includes rubber lining on pipe end

5.0 PERFORMANCE

Pressure Rating and End Load

Size		Steel Pipe (Sch. 40/Std. Wall)			Steel Pipe (Sch. 10)			Stainless Steel Pipe (Sch. 10S)		
Nominal inches DN	Actual Outside Diameter inches mm	ANSI Wall Thickness inches mm	Max Working Pressure psi kPa	Maximum Permissible End Load lb N	ANSI Wall Thickness inches mm	Max Working Pressure psi kPa	Maximum Permissible End Load lb N	ANSI Wall Thickness inches mm	Max Working Pressure psi kPa	Maximum Permissible End Load lb N
3 DN80	3.5 88.9	0.216 5.49	150 1034	1445 6427	0.120 3.0	150 1034	1445 6427	0.120 3.0	150 1034	1445 6427
4 DN100	4.5 114.3	0.237 6.02	150 1034	2385 10609	0.120 3.0	150 1034	2385 10609	0.120 3.0	150 1034	2385 10609
6 DN150	6.625 168.3	0.280 7.11	150 1034	5170 22997	0.134 3.4	150 1034	5170 22997	0.134 3.4	150 1034	5170 22997
8 DN200	8.625 219.1	0.322 8.18	150 1034	8765 38988	0.148 3.5	150 1034	8765 38988	0.148 3.8	125 862	7305 32494
10 DN250	10.75 273.1	0.365 9.27	150 1034	13615 60562	0.165 4.2	150 1034	13615 60562	0.165 4.2	125 862	11347 50473
12 DN300	12.75 323.9	0.375 9.53	150 1034	19150 85183	0.180 4.6	150 1034	19150 85183	0.180 4.6	125 862	15962 71002

Actuation Forces and Torques

Valve Size inches DN	Thrust Load lb N	Max. Torque Required ft./lb N/m	Handwheel Size inches mm	Rim Pull Effort lb N
3 DN80	1500 6672	11 14	16 406	16 71
4 DN100	2100 9341	15 20	16 406	23 102
6 DN150	3000 13344	22 30	16 406	34 151
8 DN200	4600 20461	32 44	16 406	49 218
10 DN250	7000 31136	72 100	4:1 BG with 16" HW 300	43 191
12 DN300	7200 32026	73 99	4:1 BG with 16" HW 300	44 196

Operating Torques and Pressures

- Pneumatic Air Cylinders – Designed to be operated with 80 psi/552 kPa/5 bar minimum supply air pressure and 150 psi/1034 kPa/10 bar maximum supply air pressure. Please contact Victaulic if your system air pressure is less than 80 psi/552 kPa/5 bar or more than 150 psi/1034 kPa/10 bar.
- Hydraulic Cylinders – Designed to be operated with 1500 psi/10342 kPa/103 bar minimum supply pressure and 3000 psi/20684 kPa/206 bar maximum supply pressure. Please contact Victaulic if your system hydraulic pressure is less than 1500 psi/10342 kPa/103 bar or more than 3000 psi/20684 kPa/206 bar.
- Handwheel/Bevel Gear Operator – Reference chart above.

6.0 NOTIFICATIONS

⚠ WARNING







- Read and understand all instructions before attempting to install, remove, adjust, or maintain any Victaulic piping products.
- Depressurize and drain the piping system before attempting to install, remove, adjust, or maintain any Victaulic piping products.
- Wear safety glasses, hardhat, and foot protection.

Failure to follow these instructions may cause joint failure, resulting in death or serious personal injury and property damage.

7.0 REFERENCE MATERIALS

V - 120 - 795 - G - N - E - 1 - P - 1 - A - 1

Product Class	Size	Style	Housing	Coating	Pipe/Seat Gasket	Gate Material or Coating	Actuation Type	Actuation Control Options	Enclosure Options	Hardware
V	030 - 3" 040 - 4" 060 - 6" 080 - 8" 100 - 10" 120 - 12"	795	G - Groove x Groove	N - Standard - Electroless Nickel	E - EPDM T - Nitrile	1 - 316 Stainless Steel	P - Pneumatic (3 - 12") H - Hydraulic (3 - 12") E - Electric (3 - 12") M - Handwheel (3 - 8") B - Bevel Gear (10 - 12") 9 - Special	0 - None 1 - Pneumatic with Solenoid Valve (24VDC) 2 - Pneumatic with Limit Switches (5-240V AC/DC) 3 - Pneumatic with Solenoid Valve (110-120 VAC) 4 - Pneumatic with Solenoid Valve (24VDC) and Limit Switches 5 - Pneumatic with Solenoid Valve (110-120 VAC) and Limit Switches 6 - Pneumatic with Positioner/ Transducer (4→20 mA) 7 - Hydraulic with Transducer 8 - Stem Guard for M and B Actuators 9 - Special	0 - None A - Weatherproof Enclosure B - Hazardous Location Enclosure 9 - Special	1 - Standard - Carbon Steel Zinc Plated 2 - Stainless Steel

NOTE: Electric actuation and other special actuation control options can be quoted upon request. Contact Victaulic for pricing and availability.

[29.01: Terms and Conditions/Warranty](#)

[I-100: Field Installation Handbook](#)

[I-795/906: Victaulic Series 795 and 906 Installation-Ready™ Knife Gate Valves Installation and Maintenance Instruction Manual](#)

User Responsibility for Product Selection and Suitability

Each user bears final responsibility for making a determination as to the suitability of Victaulic products for a particular end-use application, in accordance with industry standards and project specifications, and the applicable building codes and related regulations as well as Victaulic performance, maintenance, safety, and warning instructions. Nothing in this or any other document, nor any verbal recommendation, advice, or opinion from any Victaulic employee, shall be deemed to alter, vary, supersede, or waive any provision of Victaulic Company's standard conditions of sale, installation guide, or this disclaimer.

Intellectual Property Rights

No statement contained herein concerning a possible or suggested use of any material, product, service, or design is intended, or should be construed, to grant any license under any patent or other intellectual property right of Victaulic or any of its subsidiaries or affiliates covering such use or design, or as a recommendation for the use of such material, product, service, or design in the infringement of any patent or other intellectual property right. The terms "Patented" or "Patent Pending" refer to design or utility patents or patent applications for articles and/or methods of use in the United States and/or other countries.

Note

This product shall be manufactured by Victaulic or to Victaulic specifications. All products to be installed in accordance with current Victaulic installation/assembly instructions. Victaulic reserves the right to change product specifications, designs and standard equipment without notice and without incurring obligations.

Installation

Reference should always be made to the Victaulic installation handbook or installation instructions of the product you are installing. Handbooks are included with each shipment of Victaulic products, providing complete installation and assembly data, and are available in PDF format on our website at www.victaulic.com.

Warranty

Refer to the Warranty section of the current Price List or contact Victaulic for details.

Trademarks

Victaulic and all other Victaulic marks are the trademarks or registered trademarks of Victaulic Company, and/or its affiliated entities, in the U.S. and/or other countries.