

Series 795 and 906 Installation-Ready™ Knife Gate Valves



HANDWHEEL OPERATOR



PNEUMATIC OPERATOR



HYDRAULIC OPERATOR

⚠ WARNING



- Read and understand all instructions before attempting to install, remove, adjust, or maintain any Victaulic piping products.
- Depressurize and drain the piping system before attempting to install, remove, adjust, or maintain any Victaulic piping products.
- Wear safety glasses, hardhat, foot protection, and hearing protection.

Failure to follow instructions and warnings could cause system failure, resulting in death or serious personal injury and property damage.

TABLE OF CONTENTS

Hazard Identification 3
 Knife Gate Valve Components 4
 Handwheel Operator Components 5
 Pneumatic Operator Components 5
 Hydraulic Operator Components 6
 Dimensions – With Handwheel Operator 7
 Dimensions – With Bevel Gear Operator 8
 Dimensions – With Pneumatic Operator 9
 Dimensions – With Hydraulic Operator 10
 Dimensions – Seat Cartridge 11
 Important Information 12
 Recommended Spare Parts and Tools 12
 Manual Operation 12
 Pneumatic Operation 12
 Hydraulic Operation 12

SECTION I

Installing the 795 Valve Into a Steel Piping System 14
 Installing the 906 Valve Into an HDPE Piping System 18

SECTION II

Maintenance 24
 Packing Adjustment 24
 Lubrication 24
 Removing the Existing Seat Cartridge 24
 Installing the Replacement Seat Cartridge 29

HAZARD IDENTIFICATION



Definitions for identifying the various hazard levels are provided below. When you see this symbol, be alert to the possibility of personal injury. Carefully read and fully understand the message that follows.

DANGER

- The use of the word “DANGER” identifies an immediate hazard with a likelihood of death or serious personal injury if instructions, including recommended precautions, are not followed.

WARNING

- The use of the word “WARNING” identifies the presence of hazards or unsafe practices that could result in death or serious personal injury if instructions, including recommended precautions, are not followed.

CAUTION

- The use of the word “CAUTION” identifies possible hazards or unsafe practices that could result in personal injury and product or property damage if instructions, including recommended precautions, are not followed.

NOTICE

- The use of the word “NOTICE” identifies special instructions that are important but not related to hazards.

KNIFE GATE VALVE COMPONENTS

NOTICE

- Drawings and/or pictures in this manual may be exaggerated for clarity.
- Dimensions listed are for reference only. Refer to Victaulic submittal 08.25 or submittal 19.06 for complete dimensional information.
- The product, along with these installation and maintenance instructions, contains trademarks, copyrights, and/or patented features that are the exclusive property of Victaulic.

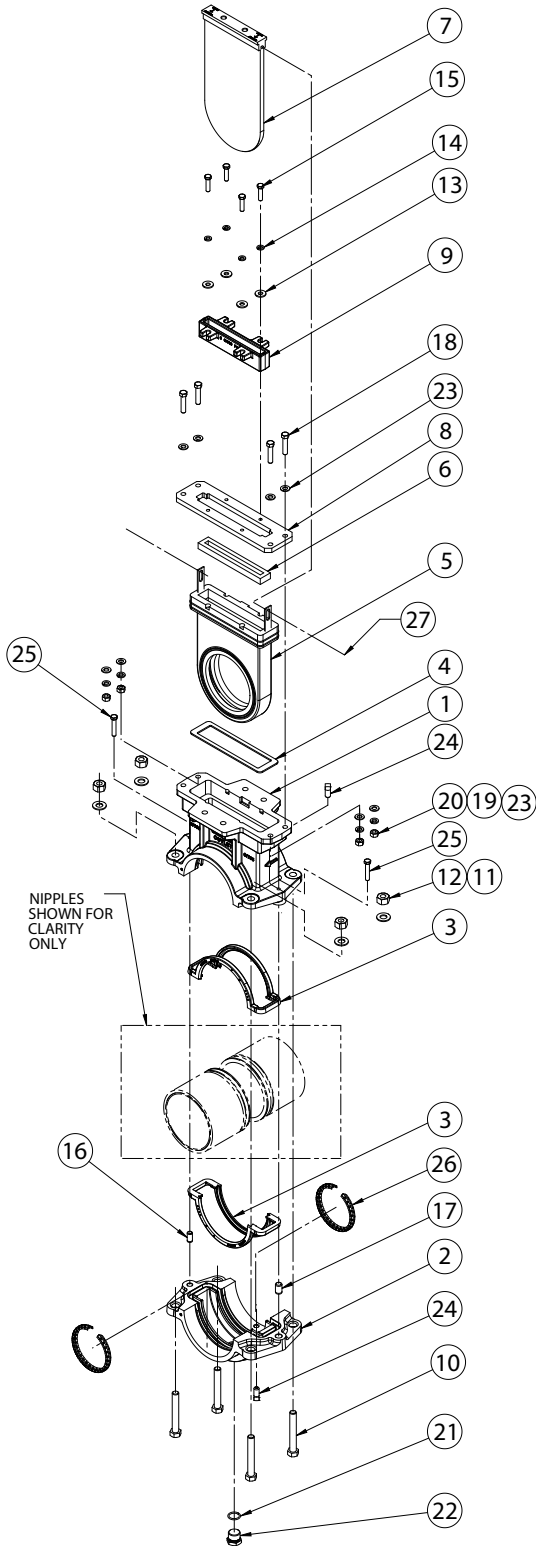

BILL OF MATERIALS

Item	Qty.	Description
1	1	Upper Body
2	1	Lower Body
3	2	Pipe Gasket
4	1	Seat Gasket
5	1	Seat
6	1	Knife Seal
7	1	Knife
8	1	Retaining Plate
9	1	Packing Gland
10	4	Full Thread Hex Bolt †
11	4	Washer †
12	4	Heavy Hex Nut †
13	4	Washer
14	4	Helical Spring-Lock Washer
15	4	Hex Cap Screw
16	1	Dowel Pin
17	1	Dowel Pin
18	4	Hex Bolt
19	4	Helical Spring-Lock Washer
20	4	Hex Nut
21	1	O-Ring
22	1	Plug
23	8	Washer
24	2	Square Head Set Screw ‡
25	2	Spacer Bolt
26	2	Retainer *
27	2	Hex Cap Screw **

NOTES:

† Items 10, 11, and 12 comprise the assembly hardware.

‡ Item 24 is used for 795 valve (carbon steel) only.

* Item 26 is used for 906 valve (HDPE) only.

** Item 27 is required when servicing the valve. Victaulic offers a kit to replace the entire seat cartridge. Refer to Section II in this manual for complete removal and replacement instructions.

HANDWHEEL OPERATOR COMPONENTS (3 TO 8 INCH)

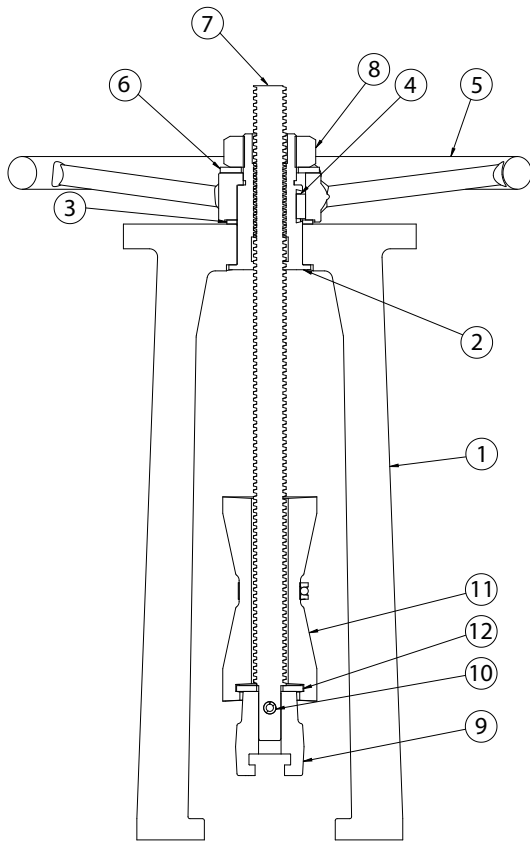

BILL OF MATERIALS

Item	Qty.	Description
1	1	Yoke
2	1	Drive Nut
3	1	Spacer
4	1	Parallel Key
5	1	Handwheel
6	1	Washer
7	1	Stem
8	1	Hex Jam Nut
9	1	Gate Connector
10	1	Slotted Spring Pin
11	1	Stroke Limiter Assembly
12	1	Washer

BEVEL GEAR COMPONENTS (10 TO 12 INCH)

BILL OF MATERIALS

Item	Qty.	Description
21	1	Yoke
22	1	Gear Actuator
23	4	Washer
24	4	Helical Spring-Lock Washer
25	4	Hex Cap Screw
26	1	Stem
27	1	Gate Connector
28	1	Slotted Spring Pin
29	1	Stroke Limiter Assembly
30	1	Washer

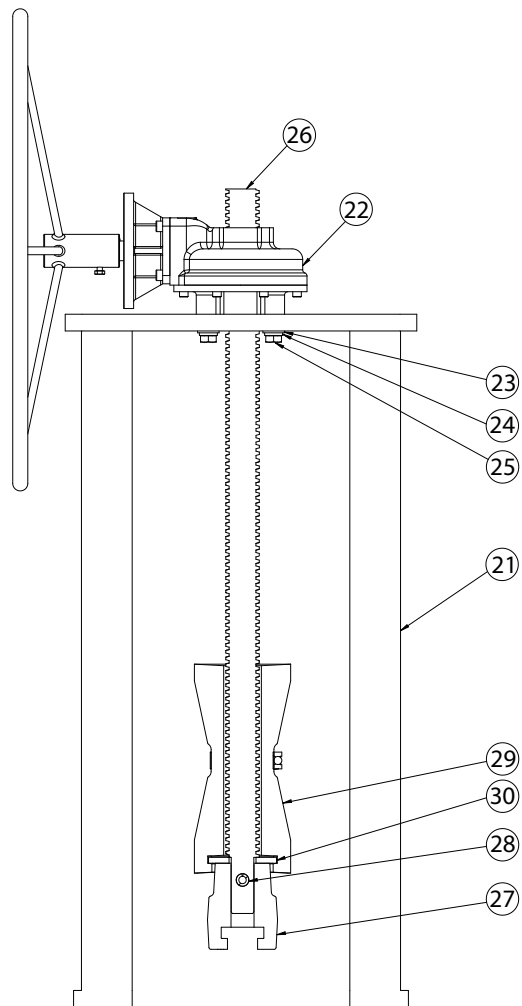

PNEUMATIC OPERATOR COMPONENTS

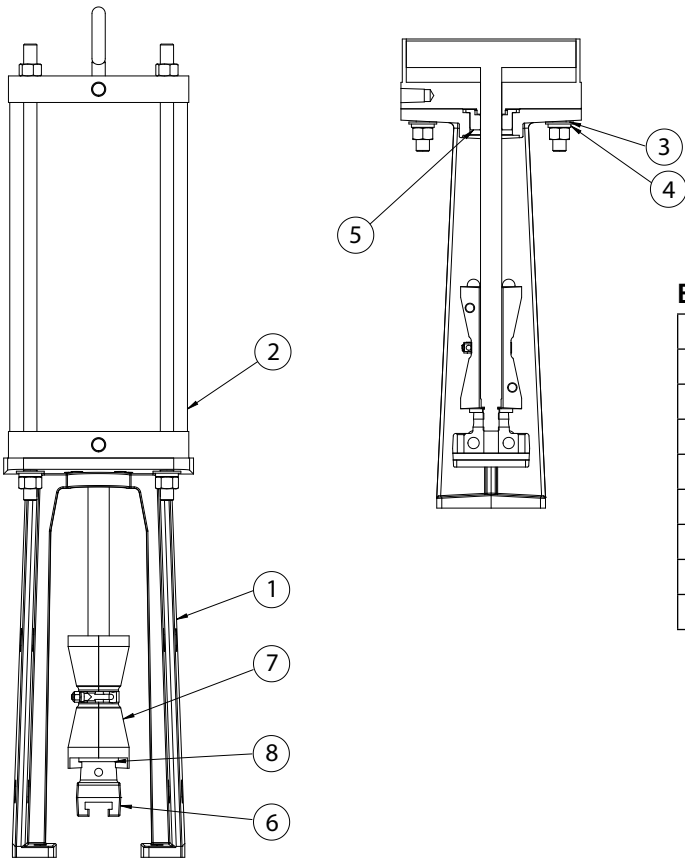

BILL OF MATERIALS

Item	Qty.	Description
1	1	Yoke
2	1	Pneumatic Cylinder with Nuts
3	4	Washer
4	4	Helical Spring-Lock Washer
5	1	Bushing
6	1	Gate Connector
7	1	Stroke Limiter Assembly
8	1	Washer

HYDRAULIC OPERATOR COMPONENTS

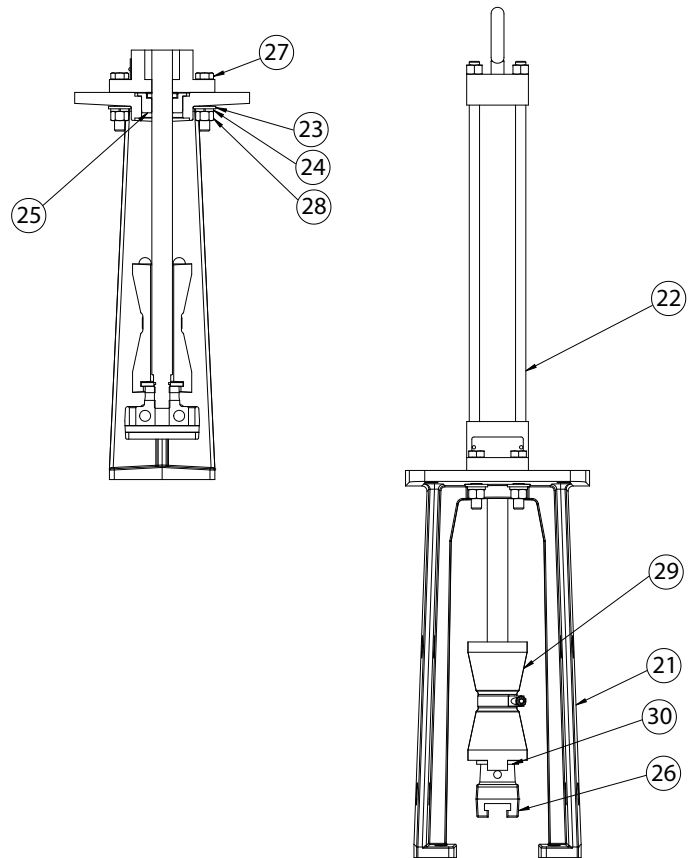

BILL OF MATERIALS

Item	Qty.	Description
21	1	Yoke
22	1	Hydraulic Cylinder
23	4	Washer
24	4	Helical Spring-Lock Washer
25	1	Bushing
26	1	Gate Connector
27	4	Hex Cap Screw
28	4	Hex Nut
29	1	Stroke Limiter Assembly
30	1	Washer

DIMENSIONS – WITH HANDWHEEL OPERATOR

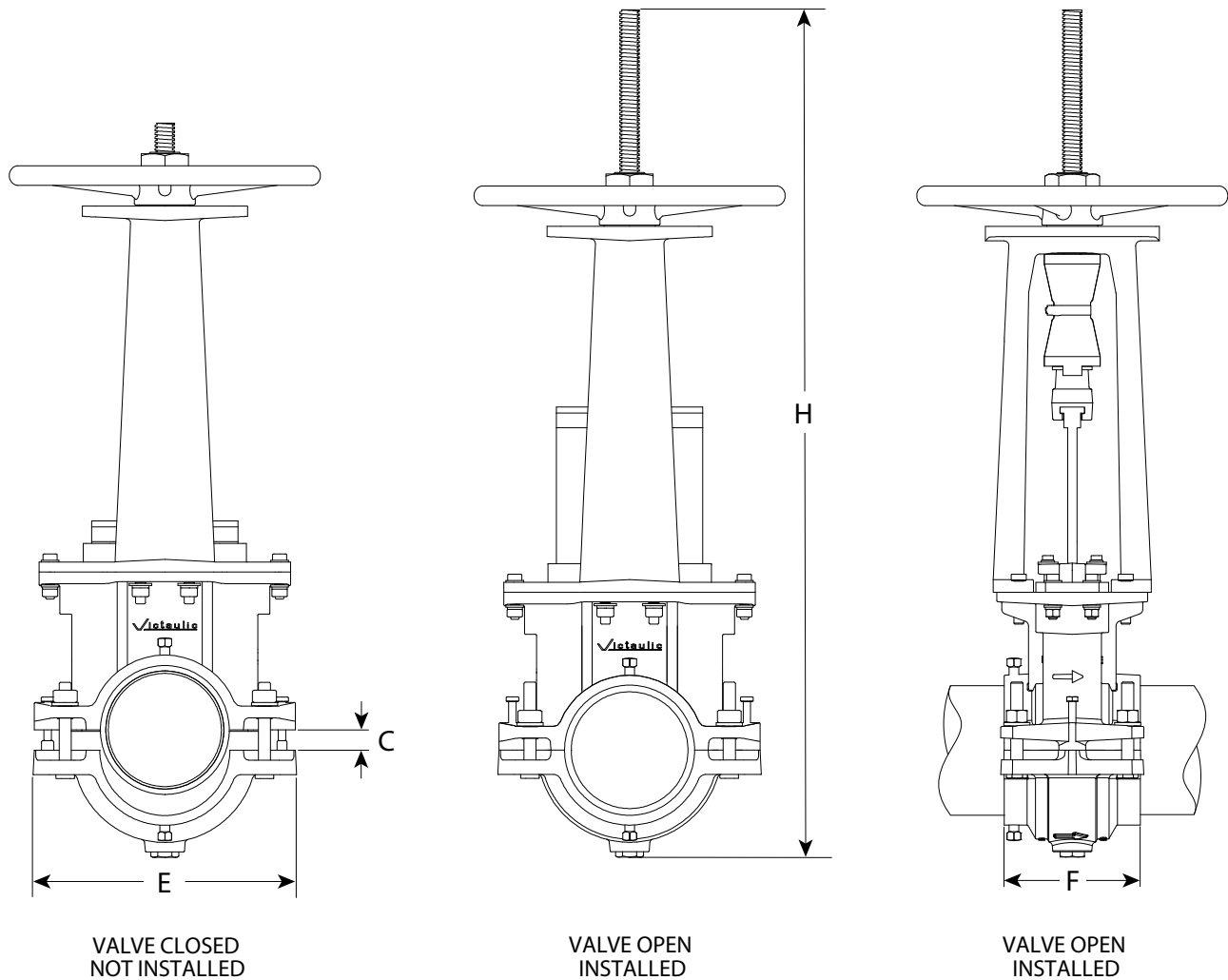

Nominal Size in DN	Dimensions – inches/millimeters				Weight lbs kg
	C	E	F	H	
3 DN80	0.88 22.4	10.25 260.4	6.75 171.5	32.25 819.2	113.00 51.3
4 DN100	0.88 22.4	11.25 285.8	6.75 171.5	34.75 882.7	122.00 55.3
6 DN150	1.13 28.7	13.75 349.3	7.00 177.8	43.75 1111.3	166.00 75.3
8 DN200	1.63 41.4	15.50 393.7	7.00 177.8	53.25 1352.6	237.00 107.5

DIMENSIONS – WITH BEVEL GEAR OPERATOR

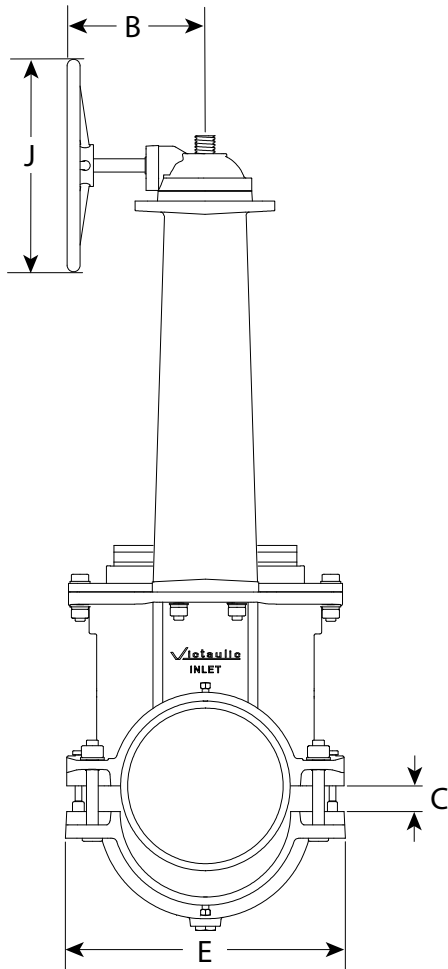

**VALVE CLOSED
NOT INSTALLED**

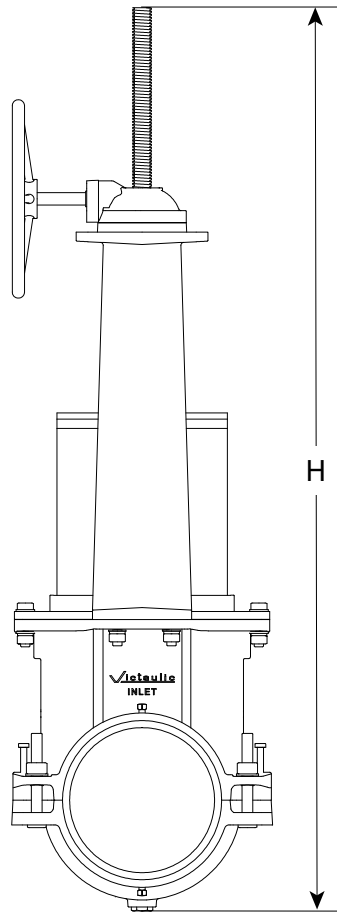

**VALVE OPEN
INSTALLED**

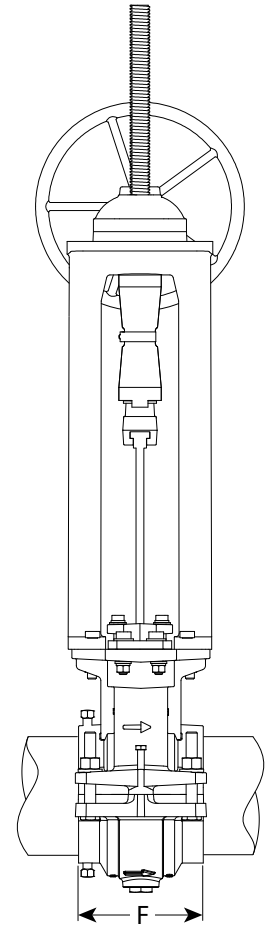

**VALVE OPEN
INSTALLED**

Nominal Size in DN	Dimensions – inches/millimeters						Weight lbs kg
	B	C	E	F	H	J	
10	11.22	1.75	19.00	7.50	68.50	16.00	465.00
DN250	284.9	44.5	482.6	190.5	1739.9	406.4	210.9
12	11.22	2.00	21.00	7.50	73.00	16.00	497.00
DN300	284.9	50.8	533.4	190.5	1854.2	406.4	225.4

DIMENSIONS – WITH PNEUMATIC OPERATOR

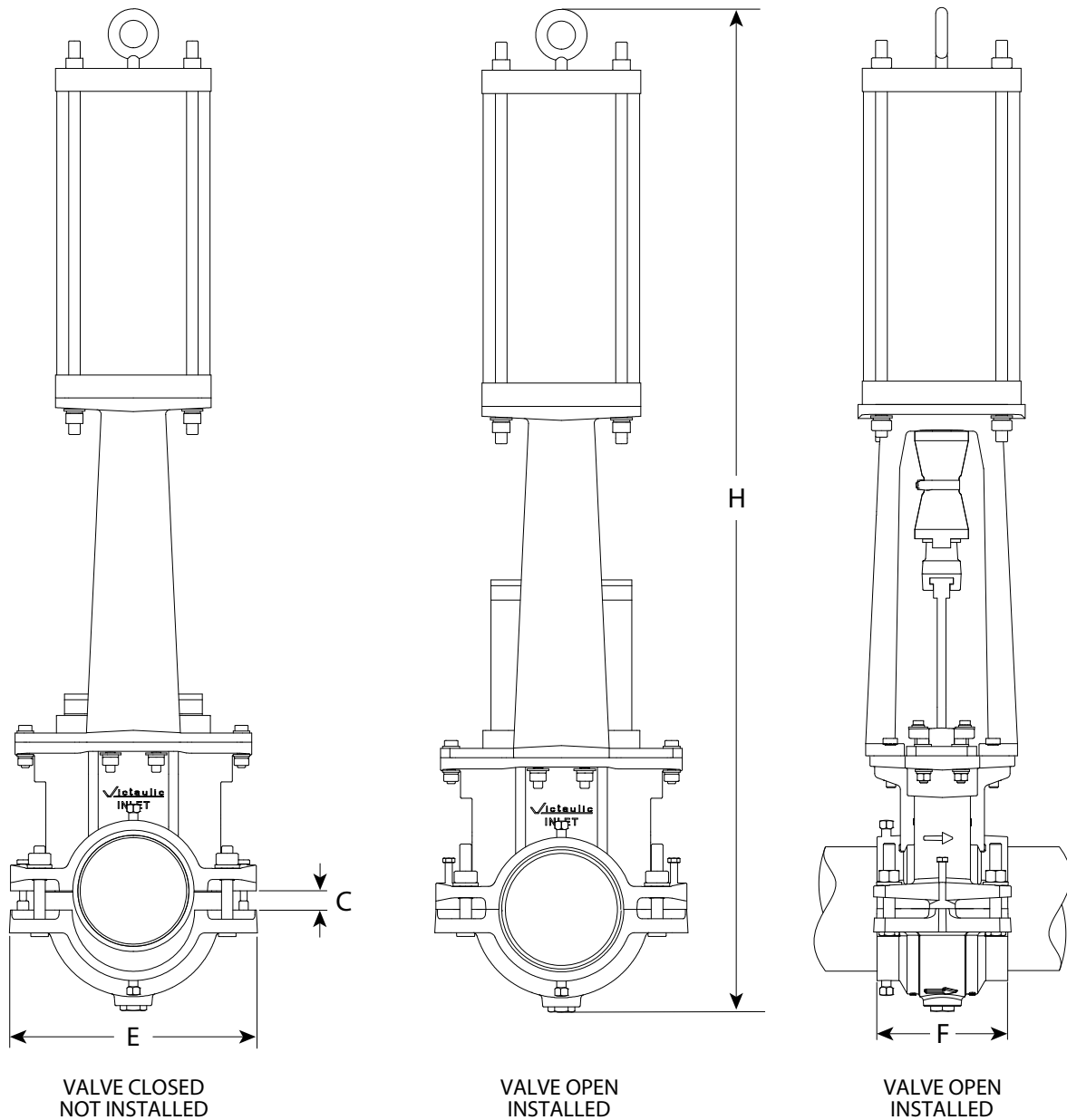

Nominal Size in DN	Dimensions – inches/millimeters				Weight lbs kg
	C	E	F	H	
3	0.88	10.25	6.75	42.00	126.00
DN80	22.4	260.4	171.5	1066.8	57.2
4	0.88	11.25	6.75	44.50	133.00
DN100	22.4	285.8	171.5	1130.3	60.3
6	1.13	13.75	7.00	53.75	215.00
DN150	28.7	349.3	177.8	1365.3	97.5
8	1.63	15.50	7.00	55.75	348.00
DN200	41.4	393.7	177.8	1416.1	157.9
10	1.75	19.00	7.50	79.50	550.00
DN250	44.5	482.6	190.5	2019.3	249.5
12	2.00	21.00	7.50	86.50	586.00
DN300	50.8	533.4	190.5	2197.1	265.8

DIMENSIONS – WITH HYDRAULIC OPERATOR

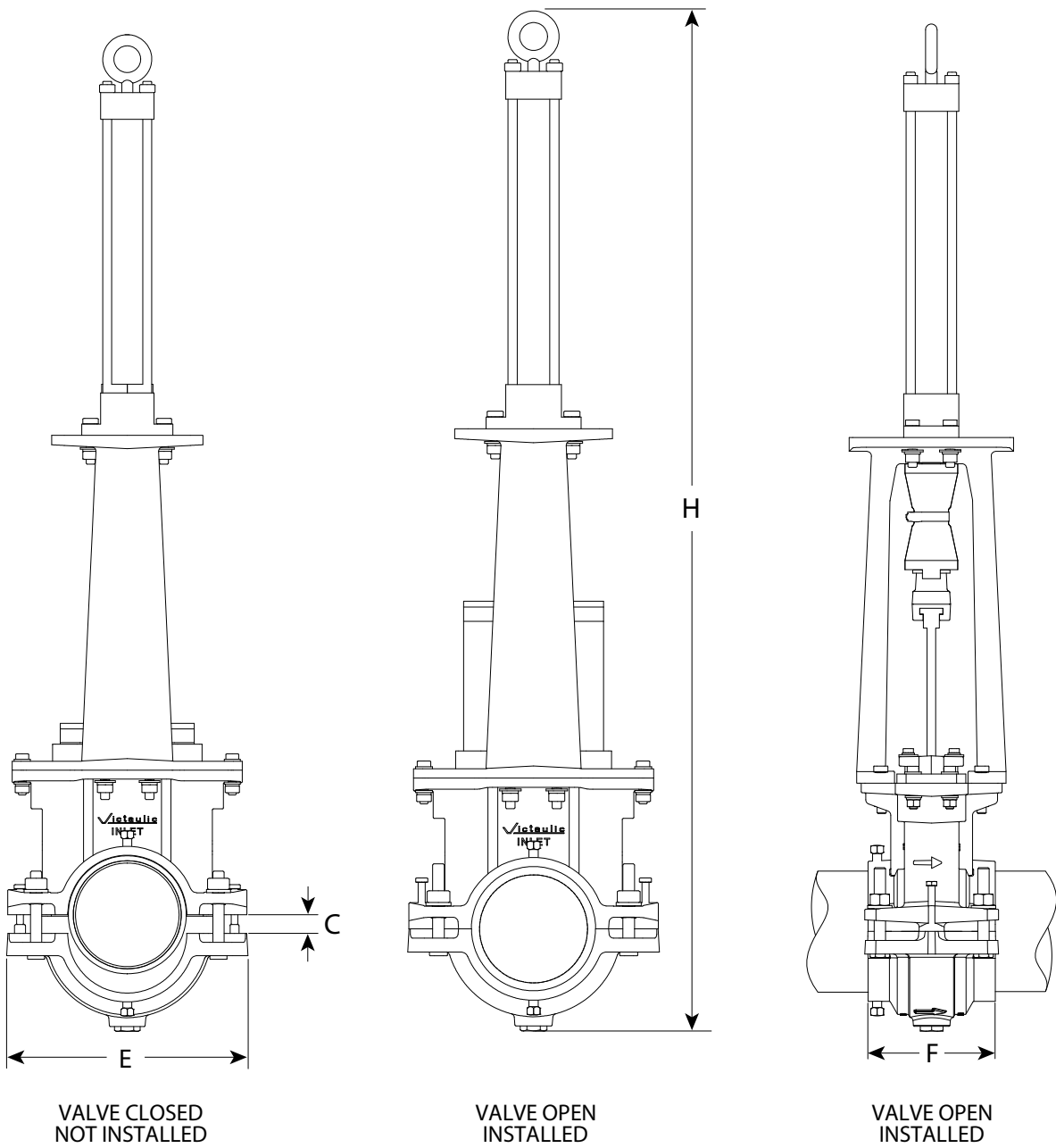

Nominal Size in DN	Dimensions – inches/millimeters				Weight lbs kg
	C	E	F	H	
3	0.88	10.25	6.75	43.88	115.00
DN80	22.4	260.4	171.5	1114.6	52.2
4	0.88	11.25	6.75	46.50	125.00
DN100	22.4	285.8	171.5	1181.1	56.7
6	1.13	13.75	7.00	55.00	172.00
DN150	28.7	349.3	177.8	1397.0	78.0
8	1.63	15.50	7.00	66.50	259.00
DN200	41.4	393.7	177.8	1689.1	117.5
10	1.75	19.00	7.50	80.25	462.00
DN250	44.5	482.6	190.5	2038.4	209.6
12	2.00	21.00	7.50	89.50	525.00
DN300	50.8	533.4	190.5	2273.3	238.1

DIMENSIONS – SEAT CARTRIDGE

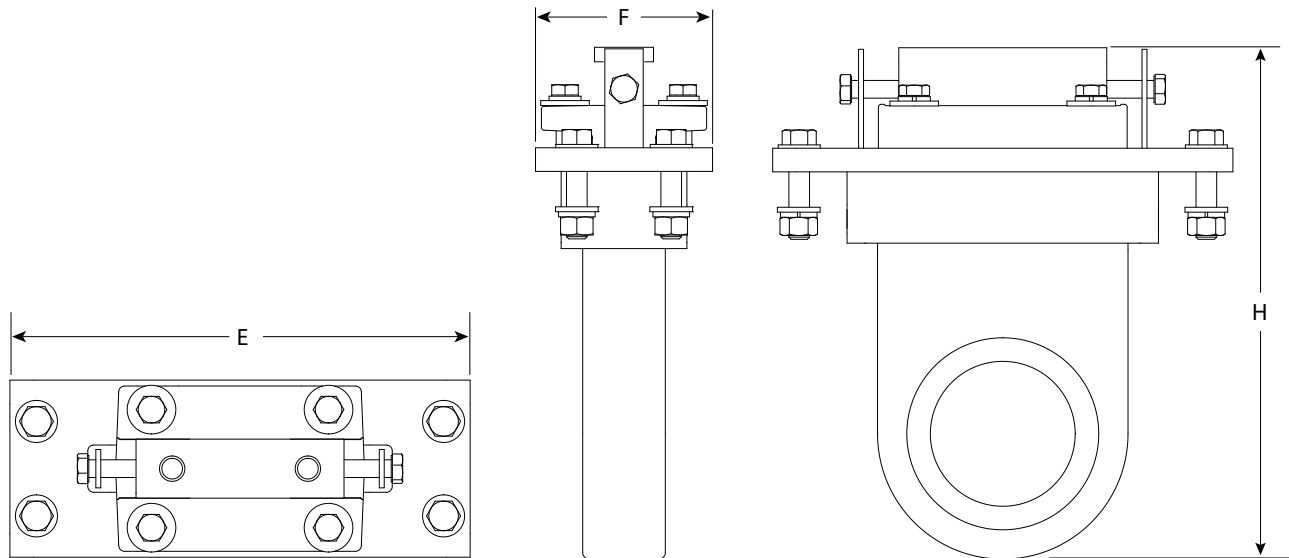

Nominal Size in DN	Dimensions – inches/millimeters			Weight lbs kg
	E	F	H	
3 DN80	9.88 251.0	3.88 98.6	10.88 276.4	16.30 7.4
4 DN100	10.75 273.1	3.88 98.6	12.13 308.1	19.70 8.9
6 DN150	13.00 330.2	3.88 98.6	15.00 381.0	28.90 13.1
8 DN200	15.50 397.3	3.88 98.6	18.25 463.6	40.70 18.5
10 DN250	19.00 482.6	5.00 127.0	23.00 584.2	82.00 37.2
12 DN300	20.63 524.0	5.00 127.0	25.50 647.7	100.60 45.6

IMPORTANT INFORMATION

- Series 795 Installation-Ready™ Knife Gate Valves are designed for installation with grooved-end carbon steel or stainless steel NPS pipe. For other pipe sizes and materials, contact Victaulic. Welding of pipe ends to the valve is not permitted. Refer to the Victaulic I-100 Field Installation Handbook for pipe preparation requirements. The I-100 can be downloaded at victaulic.com.
- Series 906 Installation-Ready™ Knife Gate Valves are designed for installation with plain-end HDPE pipe. Refer to the Victaulic I-900 Field Installation Handbook for pipe preparation requirements. The I-900 can be downloaded at victaulic.com.
- Installation-Ready™ Knife Gate Valves are rated for a maximum working pressure of 150 psi/10 Bar.
- Installation-Ready™ Knife Gate Valves are not intended for throttling service. These valves are designed for shutoff applications only.
- Installation-Ready™ Knife Gate Valves are not intended for use in air services.
- Installation-Ready™ Knife Gate Valves can be installed in any orientation. **NOTE:** Additional supports shall be considered when a 795 valve is installed horizontally, especially when a pneumatic, electric, or hydraulic actuator is used. The 906 valve must be fully supported in all installations.
- Installation-Ready™ Knife Gate Valves and connecting piping must be supported properly to prevent the joints from being subjected to bending loads, shear loads, or any other external loads.

- DO NOT use Installation-Ready™ Knife Gate Valves as a jack for pipe alignment or support.
- DO NOT climb on or stand on Installation-Ready™ Knife Gate Valves or other piping system components.

RECOMMENDED SPARE PARTS AND TOOLS

CAUTION

- Ensure that all spare seals and gaskets are compatible with the line temperature and media.
- Failure to follow this instruction will cause gasket degradation, resulting in joint leakage and property damage.**

- Spare Seat Cartridge
- Ratchet Wrenches
- Crescent Wrenches
- Pipe Wrenches
- Victaulic Lubricant or Silicone Lubricant
- Water-Stabilized Calcium Grease Containing Graphite and Molybdenum Disulfide
- Anti-Seize Compound

MANUAL OPERATION

For Installation-Ready™ Knife Gate Valves installed with a handwheel operator, the following table contains the approximate number of complete rotations required during standard operation (i.e. going from fully closed to fully open) or during maintenance to remove the seat cartridge.

Valve Size inches mm	Thrust Load lbs N	Approximate Number of Handwheel Rotations for Standard Operation	Approximate Number of Handwheel Rotations for Maintenance	Maximum Torque Required ft-lbs N•m	Rim Pull Effort lb N
3 80	1500 6672	20	45	11 14	16 70
4 100	2100 9341	25	55	15 20	22 99
6 150	3000 13,344	35	70	22 29	33 145
8 200	4600 20,461	45	90	33 44	49 217
10* 250	7000 31,136	44	88	72 98	43 189
12* 300	7200 32,026	52	100	73 99	43 192

* These sizes come standard with a bevel gear operator.

PNEUMATIC OPERATION

Pneumatic cylinders are designed to be operated within 80–150 psi/6–10 Bar air pressure. Contact Victaulic if your system air pressure is less than 80 psi/6 Bar. Additional information will be required to determine appropriate specifications for your system.

HYDRAULIC OPERATION

Hydraulic cylinders are designed to be operated within 1500–3000 psi/103–207 Bar hydraulic pressure. Contact Victaulic if your system hydraulic pressure is less than 1500 psi/103 Bar. Additional information will be required to determine appropriate specifications for your system.

SECTION I

- **Installing the 795 Valve Into a Steel Piping System**
- **Installing the 906 Valve Into an HDPE Piping System**

INSTALLING THE 795 VALVE INTO A STEEL PIPING SYSTEM

WARNING

- This valve is intended for use on grooved-end carbon steel or stainless steel NPS pipe and is NOT to be used on HDPE pipe. Failure to follow this instruction could result in personal injury, joint leakage, and property damage, and could void the product warranty.

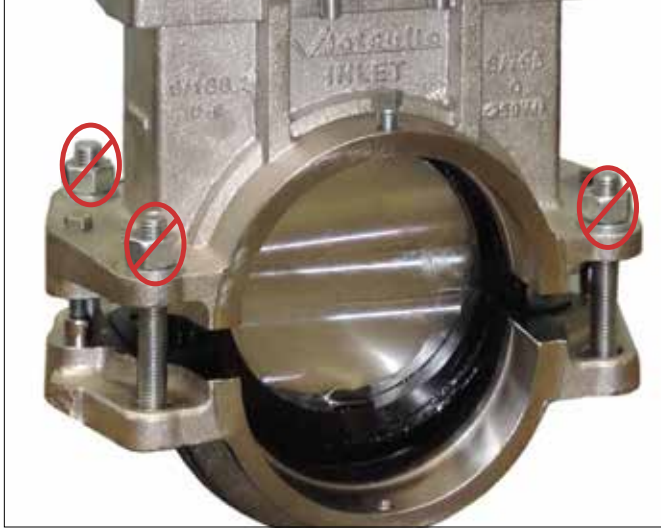

1. DO NOT REMOVE OR ADJUST THE ASSEMBLY HARDWARE: Series 795 Installation-Ready™ Knife Gate Valves are designed so that the installer does not need to remove the assembly hardware for installation. This design facilitates installation by allowing the installer to directly insert a grooved pipe end into each opening of the valve.



2. INSPECT PIPE ENDS: The outside surface of the pipe, between the groove and the pipe end, must be smooth and free from indentations, projections, weld seams, and roll marks to ensure a leak-tight seal. All oil, grease, loose paint, dirt, and cutting particles must be removed. The pipe OD, groove dimensions, and maximum allowable flare diameter must be within the tolerances published in current Victaulic grooving specifications. **NOTE:** Maximum allowable pipe ovality shall comply with the requirements of ASTM A-999 and API 5L. Greater variations between the major and minor pipe diameters will result in difficult assembly and potential joint leakage.

3. INSPECT PIPE GASKETS: Check the pipe gaskets to ensure that they are suitable for the intended service. The color code identifies the gasket grade. Refer to Victaulic publication 05.01 in the G-100 General Catalog for the color code chart.

CAUTION

- A compatible lubricant must be used to prevent the pipe gaskets from pinching/tearing during installation.
- Pipe gaskets are designed for one-time use only. **DO NOT** attempt to reuse pipe gaskets that have been placed in service. Failure to follow these instructions will cause gasket degradation, resulting in joint leakage and property damage.

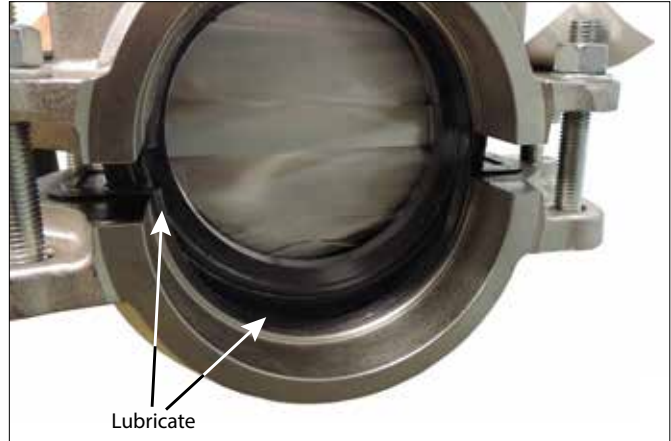

4. LUBRICATE PIPE GASKETS: Apply a thin coat of Victaulic Lubricant or silicone lubricant only to the sealing lips of the pipe gaskets' interior. **NOTE:** The exterior surface of the pipe gaskets is supplied with a factory-applied lubricant.

NOTICE

- It is not necessary to remove the pipe gaskets from the valve to apply additional lubricant to the exterior surface.

TABLE 1: LUBRICANT COMPATIBILITY

Lubricant	Compatibility with Grade "T" Nitrile Gaskets	Compatibility with Grade "E" EPDM Gaskets
Victaulic Lubricant, Soap-Based Solutions, Glycerin, Silicone Oil, or Silicone Release Agent	Good	Good
Corn Oil, Soybean Oil, Hydrocarbon-Based Oils, or Petroleum-Based Greases	Good	Not Recommended

WARNING

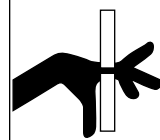

- Keep hands away from the pipe ends and the openings of the valve when attempting to insert grooved pipe ends into the valve. Failure to follow this instruction could result in serious personal injury.



5a. ASSEMBLE JOINT: Assemble the joint by inserting a grooved pipe end into each opening of the valve.

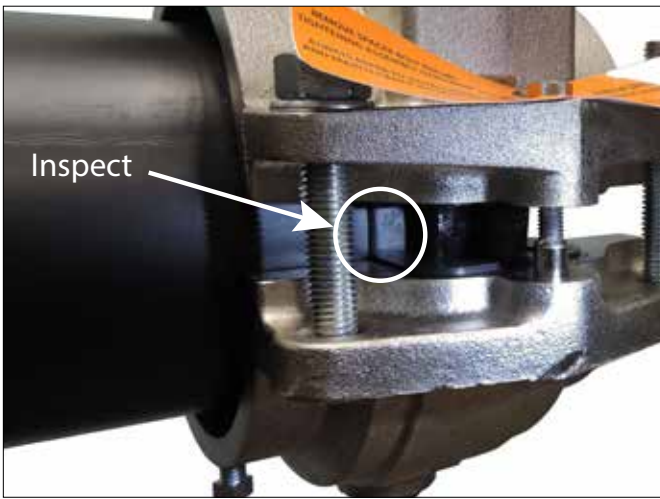

5b. INSPECT KEYS: Each grooved pipe end must be inserted into the valve until contact with the seat occurs, as shown above. This will ensure that the valve body's keys align with the grooves in the pipe ends.



5c. REMOVE ONLY THE SPACER BOLTS: There is one spacer bolt on each bolt pad to maintain spacing between the bolt pads during shipping and assembly. After inserting pipe, remove only the spacer bolts and the attached warning tags before tightening the four nuts in step 6.

⚠ CAUTION

- Spacer bolts are designed to keep the valve's housings at the proper spacing during installation of the pipe ends.
- These spacer bolts must be removed prior to tightening the hex nuts to bring the bolt pads into metal-to-metal contact. The bolts will prevent proper tightening of the valve housings.

Failure to follow these instructions will cause damage to the valve components. This may result in joint leakage or property damage, and could void the product warranty.

NOTE: Do NOT discard the spacer bolts. Reinstall the spacer bolts to finger-tight after valve installation is complete. If the valve must be removed from the system, the spacer bolts will be necessary to separate housings and maintain spacing (dimension "C", as defined in the dimension tables found on pages 7–10) between the bolt pads during storage, shipping, and reinstallation.

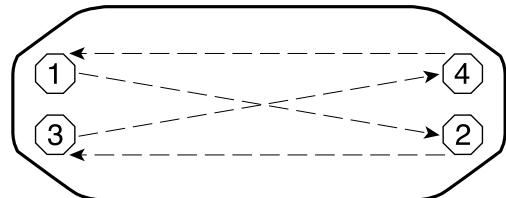
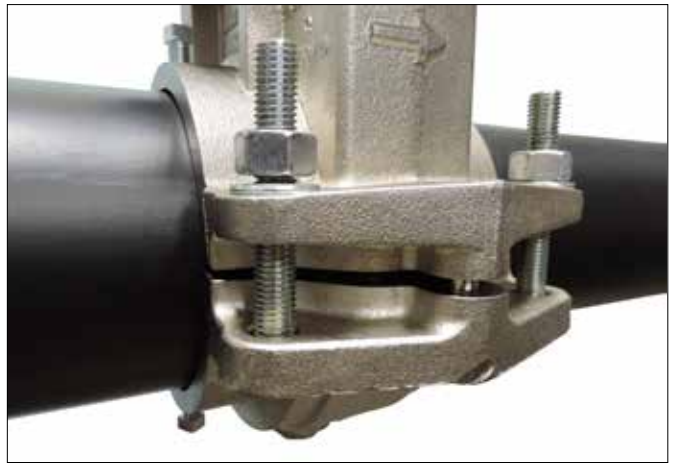

6. TIGHTEN NUTS: Tighten the hex nuts evenly by alternating sides in a crossing pattern (as shown in the sequence above) until metal-to-metal contact occurs at the bolt pads. Ensure that the valve body's keys engage the grooves completely during tightening.

NOTE: It is important to tighten the hex nuts evenly by alternating sides to prevent pinching of the pipe gaskets. An impact wrench or standard socket wrench with a deep-well socket can be used to bring the bolt pads into metal-to-metal contact. Refer to the "Series 795 Helpful Information" and "Impact Wrench Usage Guidelines" sections.

⚠ WARNING

- Visual inspection of each joint is critical.
- Improperly assembled joints must be corrected before the system is placed into service.

Failure to follow these instructions could cause joint failure, resulting in serious personal injury and/or property damage.

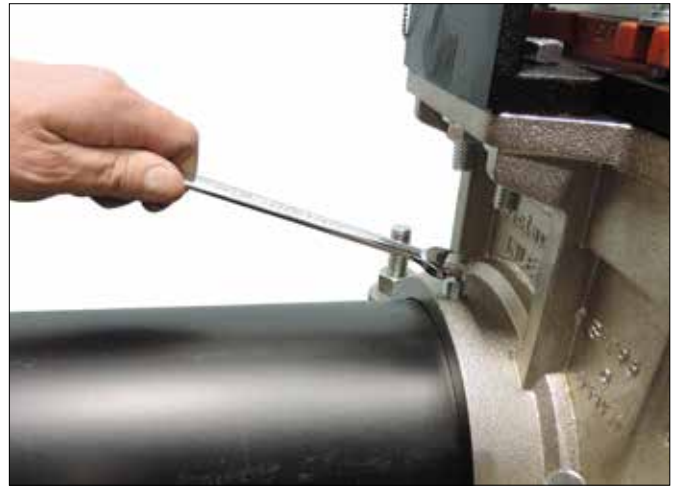
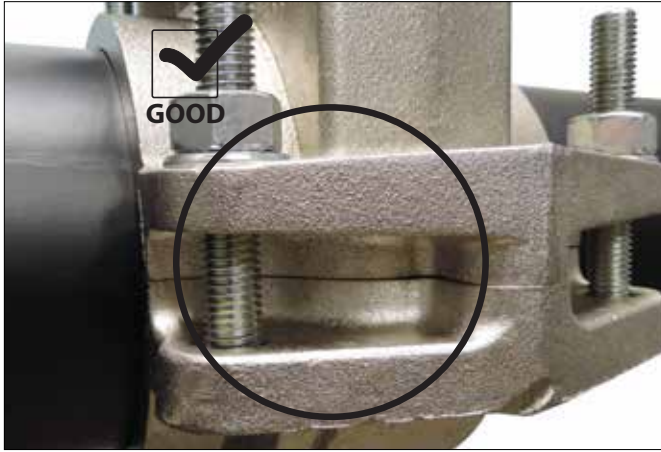

7. INSPECT PADS: Visually inspect the bolt pads at each joint to ensure that metal-to-metal contact is achieved across the entire bolt pad section.

8. TIGHTEN 360° POSITIONING BOLTS: Tighten the two 360° positioning bolts evenly by alternating sides until they reach a nominal torque of 40 ft-lbs/54.23 N•m.

NOTICE

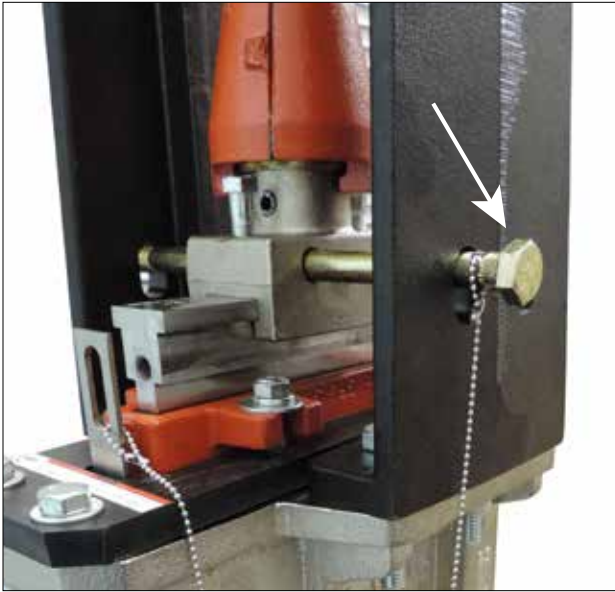

A locking pin is provided to assist with Lockout/Tagout procedures during installation and maintenance. Ensure that the pin is removed before attempting to place the valve into service.

IMPACT WRENCH USAGE GUIDELINES

⚠ WARNING

- It is important to tighten the nuts evenly by alternating sides until metal-to-metal contact occurs at the bolt pads.
- **DO NOT** continue to tighten the nuts after the visual installation guidelines for the product are achieved.

Failure to follow these instructions could cause gasket pinching and product damage, resulting in joint failure, serious personal injury, and property damage.

Due to the speed of assembly when using an impact wrench, the installer should take extra care to ensure that nuts are tightened evenly by alternating sides until proper assembly is complete. Always refer to the specific product installation instructions for complete installation requirements.

Impact wrenches do not provide the installer with direct “wrench feel” or torque to judge nut tightness. Since some impact wrenches are capable of high output, it is important to develop a familiarity with the impact wrench to avoid damaging or fracturing the bolts or the bolt pads during installation. **DO NOT continue to tighten the nuts after the visual installation guidelines are achieved.**

If the battery is drained or if the impact wrench is under-powered, a new impact wrench or a new battery pack must be used to ensure that the visual installation guidelines for the product are achieved.

Perform trial assemblies with the impact wrench and check the assemblies with socket or torque wrenches to help determine the capability of the impact wrench. Using the same method, periodically check additional nuts throughout the system installation.

For safe and proper use of impact wrenches, always refer to the impact wrench manufacturer’s operating instructions. In addition, verify that proper impact grade sockets are being used for product installation.

⚠ WARNING

Failure to follow instructions for tightening product hardware could result in:

- Bolt fractures
- Damaged or broken bolt pads or product fractures
- Joint leakage

Series 795 Helpful Information

Valve Size	Spacer Bolt Size	Spacer Bolt Socket inches/mm	Coupling Nut Size	Coupling Nut Deep-Well Socket inches/mm
3	3/8" - 16 UNC x 2"	9/16	1/2" - 13 Heavy Hex	7/8
		14		19
4	3/8" - 16 UNC x 2"	9/16	1/2" - 13 Heavy Hex	7/8
		14		19
6	3/8" - 16 UNC x 3"	9/16	5/8" - 11 Heavy Hex	1 1/16
		14		27
8	3/8" - 16 UNC x 3"	9/16	5/8" - 11 Heavy Hex	1 1/16
		14		27
10	1/2" - 13 UNC x 3.5"	3/4	7/8" - 9 Heavy Hex	1 7/16
		19		36
12	1/2" - 13 UNC x 3.5"	3/4	7/8" - 9 Heavy Hex	1 7/16
		19		36

INSTALLING THE 906 VALVE INTO AN HDPE PIPING SYSTEM

⚠ WARNING



- Wear gloves while handling valve. Retainer teeth are sharp and may cause injury.
- This valve is intended for use on plain-end HDPE pipe and is NOT to be used on steel pipe.

Failure to follow these instructions could result in personal injury, joint leakage, and property damage, and could void the product warranty.

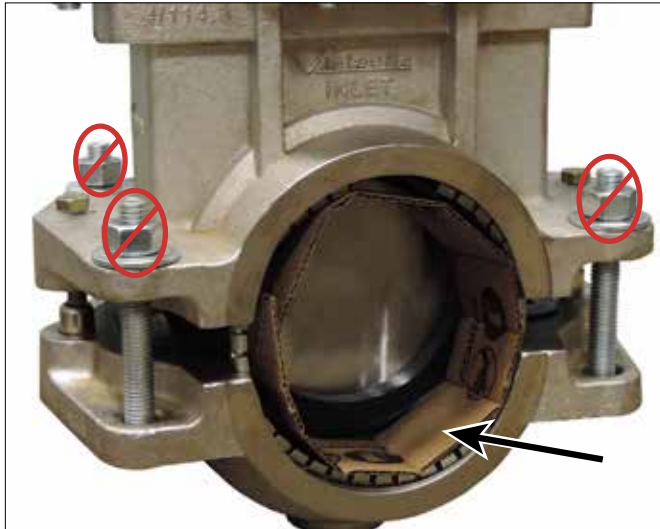

1a. DO NOT REMOVE OR ADJUST THE ASSEMBLY HARDWARE:

Series 906 Installation-Ready™ Knife Gate Valves are designed so that the installer does not need to remove the assembly hardware for installation. This design facilitates installation by allowing the installer to directly insert a pipe end into each opening of the valve.

1b. REMOVE SLEEVE: Remove the cardboard sleeve from the valve interior. **NOTE:** This cardboard sleeve will be used as a guide for marking the pipe ends in step 4.



2. INSPECT PIPE ENDS: Ensure that the pipe ends are clean and free from damage and scratches within 2½ inches/64 mm from the ends. All oil, grease, dirt, and cutting particles must be removed. Failure to do so will result in difficult assembly and potential joint leakage.

3. INSPECT PIPE GASKETS: Check the pipe gaskets to ensure that they are suitable for the intended service. The color code identifies the gasket grade. Refer to Victaulic publication 05.01 in the G-100 General Catalog for the color code chart.

⚠ CAUTION

- A compatible lubricant must be used to prevent the pipe gaskets from pinching/tearing during installation.
- Pipe gaskets are designed for one-time use only. **DO NOT** attempt to reuse pipe gaskets.

Failure to follow these instructions will cause gasket degradation, resulting in joint leakage and property damage.



4. MARK PIPE: Using the cardboard sleeve and a paint stick, mark each HDPE pipe end around the full circumference:

- 1⅞ inches/48 mm for 2–3-inch pipe sizes
- 2¼ inches/57 mm for 4–8-inch pipe sizes

This mark will be used for visual inspection to ensure that the HDPE pipe is inserted properly in the valve. If a full circumferential mark cannot be achieved, make at least four marks equally-spaced around the circumference of each HDPE pipe end.



5. LUBRICATE PIPE END: Apply a thin coat of lubricant to the pipe end from the end of the pipe to the paint mark made in step 4.

Lubricate each pipe end in accordance with the “Lubricant Compatibility” table. Always consult with the pipe manufacturer for lubricant compatibility requirements.

TABLE 1: LUBRICANT COMPATIBILITY

Lubricant	Compatibility with Grade "T" Nitrile Gaskets	Compatibility with Grade "E" EPDM Gaskets
Victaulic Lubricant, Soap-Based Solutions, Glycerin, Silicone Oil, or Silicone Release Agent	Good	Good
Corn Oil, Soybean Oil, Hydrocarbon-Based Oils, or Petroleum-Based Greases	Good	Not Recommended

⚠ WARNING

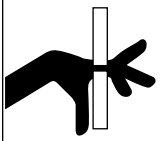

- Keep hands away from the pipe ends and the openings of the valve when attempting to insert pipe ends into the valve.

Failure to follow this instruction could result in personal injury.

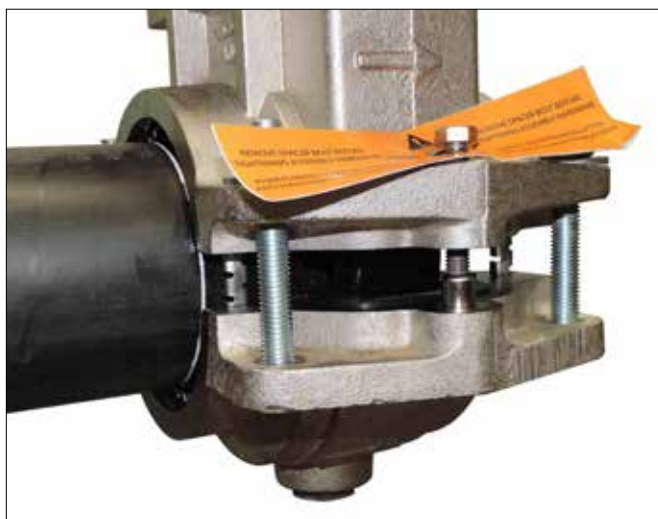

5a. ASSEMBLE JOINT: Assemble the joint by inserting the marked HDPE pipe end into each opening of the valve. The HDPE pipe ends must be inserted into the valve until (1) contact with the seat occurs AND (2) the marks on the HDPE pipe ends meets the edge of the valve body, as shown above.

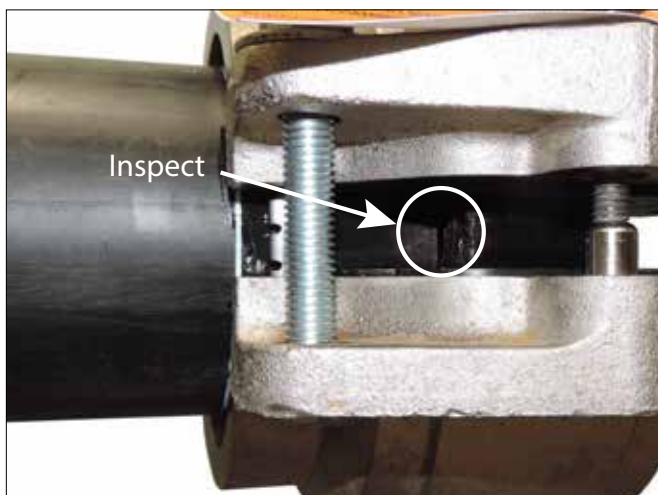

5b. INSPECT SEAT: Each pipe end must be inserted into the valve until contact with the seat occurs, as shown above. A visual check is required to ensure that the seat meets the pipe ends.



5c. REMOVE ONLY THE SPACER BOLTS: There is one spacer bolt on each bolt pad to maintain spacing between the bolt pads during shipping and assembly. After inserting pipe, remove only the spacer bolts and the attached warning tags before tightening the four nuts in step 6.

⚠ CAUTION

- Spacer bolts are designed to keep the valve's housings at the proper spacing during installation of the pipe ends.
- These spacer bolts must be removed prior to tightening the hex nuts to bring the bolt pads into metal-to-metal contact. The bolts will prevent proper tightening of the valve housings.

Failure to follow these instructions will cause damage to the valve components. This may result in joint leakage or property damage, and could void the product warranty.

NOTE: Do NOT discard the spacer bolts. Reinstall the spacer bolts to finger-tight after valve installation is complete. If the valve must be removed from the system, the spacer bolts will be necessary to separate housings and maintain spacing (dimension "C", as defined in the dimension tables found on pages 7–10) between the bolt pads during storage, shipping, and reinstallation.

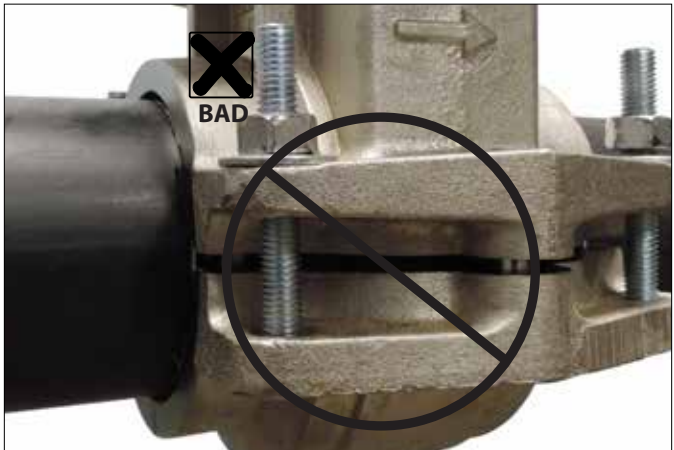
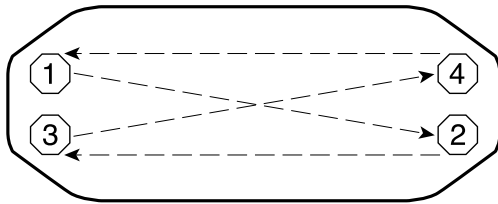
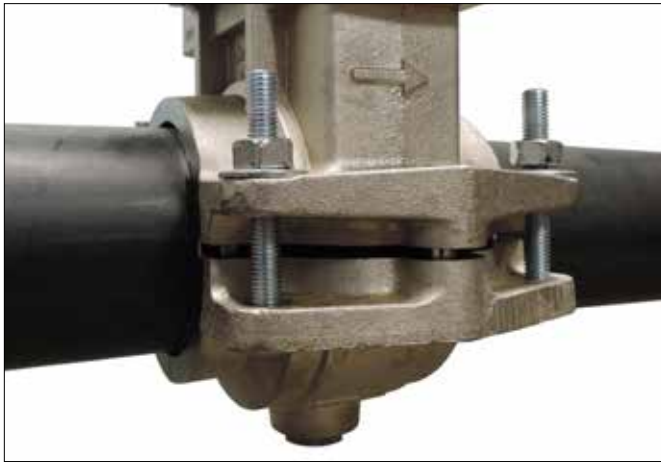

6. TIGHTEN NUTS: Tighten the hex nuts evenly by alternating sides in a crossing pattern (as shown in the sequence above) until metal-to-metal contact occurs at the bolt pads.

NOTE: It is important to tighten the hex nuts evenly by alternating sides to prevent pinching of the pipe gaskets. An impact wrench or standard socket wrench with a deep-well socket can be used to bring the bolt pads into metal-to-metal contact. Refer to the “Series 906 Helpful Information” and “Impact Wrench Usage Guidelines” sections.

⚠ WARNING

- Visual inspection of each joint is critical.
- Improperly assembled joints must be corrected before the system is placed into service.

Failure to follow these instructions could cause joint failure, resulting in serious personal injury and/or property damage.

7. INSPECT PADS: Visually inspect the bolt pads at each joint to ensure that metal-to-metal contact is achieved across the entire bolt pad section.

NOTICE

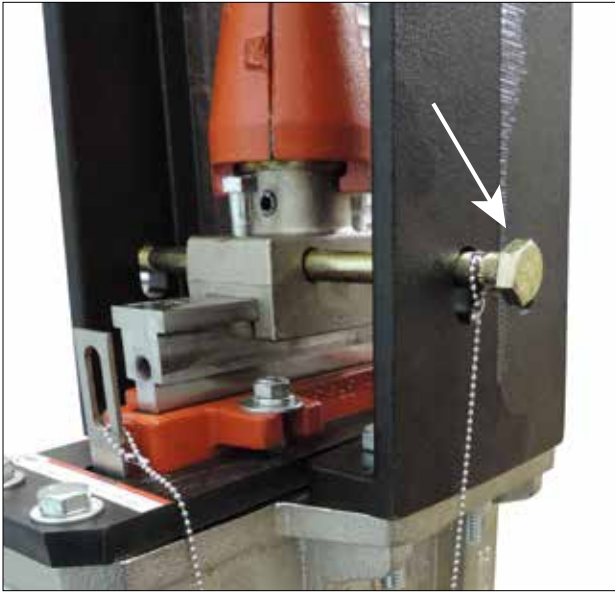

A locking pin is provided to assist with Lockout/Tagout procedures during installation and maintenance. Ensure that the pin is removed before attempting to place the valve into service.

IMPACT WRENCH USAGE GUIDELINES

⚠ WARNING

- It is important to tighten the nuts evenly by alternating sides until metal-to-metal contact occurs at the bolt pads.
- **DO NOT** continue to tighten the nuts after the visual installation guidelines for the product are achieved.

Failure to follow these instructions could cause gasket pinching and product damage, resulting in joint failure, serious personal injury, and property damage.

Due to the speed of assembly when using an impact wrench, the installer should take extra care to ensure that nuts are tightened evenly by alternating sides until proper assembly is complete. Always refer to the specific product installation instructions for complete installation requirements.

Impact wrenches do not provide the installer with direct “wrench feel” or torque to judge nut tightness. Since some impact wrenches are capable of high output, it is important to develop a familiarity with the impact wrench to avoid damaging or fracturing the bolts or the bolt pads during installation. **DO NOT continue to tighten the nuts after the visual installation guidelines are achieved.**

If the battery is drained or if the impact wrench is under-powered, a new impact wrench or a new battery pack must be used to ensure that the visual installation guidelines for the product are achieved.

Perform trial assemblies with the impact wrench and check the assemblies with socket or torque wrenches to help determine the capability of the impact wrench. Using the same method, periodically check additional nuts throughout the system installation.

For safe and proper use of impact wrenches, always refer to the impact wrench manufacturer’s operating instructions. In addition, verify that proper impact grade sockets are being used for product installation.

⚠ WARNING

Failure to follow instructions for tightening product hardware could result in:

- Bolt fractures
- Damaged or broken bolt pads or product fractures
- Joint leakage

Series 906 Helpful Information

Valve Size	Spacer Bolt Size	Spacer Bolt Socket inches/mm	Coupling Nut Size	Coupling Nut Deep-Well Socket inches/mm
3	3/8" - 16 UNC x 2"	9/16	1/2" - 13 Heavy Hex	7/8
		14		19
4	3/8" - 16 UNC x 2"	9/16	1/2" - 13 Heavy Hex	7/8
		14		19
6	3/8" - 16 UNC x 3"	9/16	5/8" - 11 Heavy Hex	1 1/16
		14		27
8	3/8" - 16 UNC x 3"	9/16	5/8" - 11 Heavy Hex	1 1/16
		14		27

This page intentionally blank

SECTION II

- **Maintenance**
- **Removing the Seat Cartridge**
- **Installing the Seat Cartridge**

MAINTENANCE

Maintenance should be performed on the Installation-Ready™ Knife Gate Valve on a regularly scheduled basis, as established by job site requirements, or when leakage occurs.

PACKING ADJUSTMENT

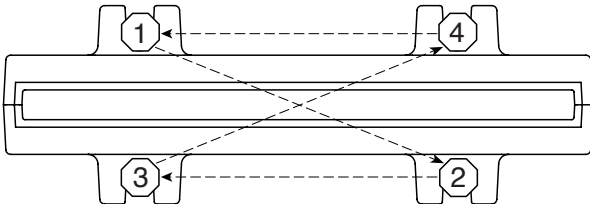
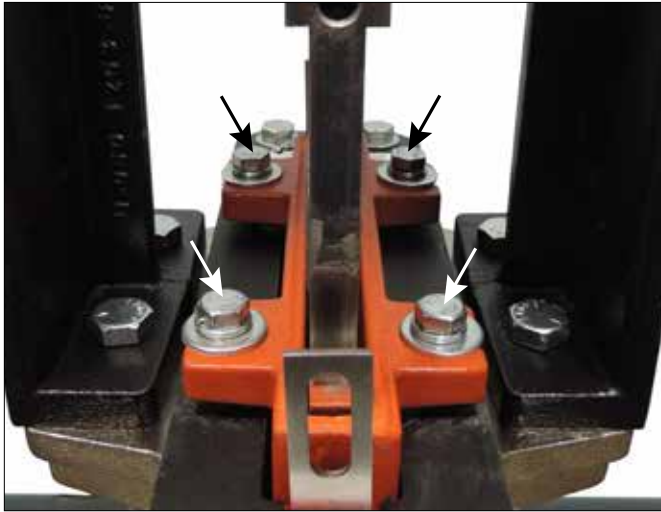

If leakage occurs at the packing, tighten the hex cap screws evenly in $\frac{1}{4}$ turns by alternating sides (as shown in the sequence above) until leakage stops. If leakage persists, perform the instructions that follow to remove and replace the seat cartridge.

LUBRICATION



For handwheel, bevel gear, or electrically operated valves, Victaulic recommends greasing the threaded stem and drive nut on a quarterly basis, depending on the number of cycles. If the valve is cycled on a daily basis, increase the frequency of lubricating the threaded stem to ensure proper handwheel operation.

Apply a water-stabilized calcium grease containing graphite and molybdenum disulfide (Mobil Mobilux™ EP 1 or equivalent) to the entire threaded stem and

drive nut. Operate the handwheel to raise and lower the threaded stem to ensure that grease is distributed evenly. **NOTE:** If the valve is in a critical shutoff service and cannot be cycled, insert the locking pin (referenced on page 17) through the yoke (page 5, item 1) into the gate connector (page 5, item 9). Disconnect the threaded stem (page 5, item 7) from the gate connector by removing the slotted spring pin (page 5, item 10). Cycle the threaded stem independent of the gate connector, then replace the slotted spring pin and remove the lockout bolt.

For pneumatically or hydraulically operated valves, refer to the actuator manufacturer's maintenance instructions.

™ Mobilux is a trademark of Exxon Mobil Corporation.

REMOVING THE EXISTING SEAT CARTRIDGE

⚠ DANGER	
	<ul style="list-style-type: none"> Depressurize and drain the piping system completely before attempting to remove the seat cartridge. <p>Failure to follow this instruction could result in death or serious personal injury and property damage.</p>

⚠ WARNING	
	<ul style="list-style-type: none"> Read and understand all instructions before attempting to install, remove, adjust, or maintain any Victaulic piping products. Wear safety glasses, hardhat, foot protection, and hearing protection. <p>Failure to follow instructions and warnings could cause system failure, resulting in death or serious personal injury and property damage.</p>

1. DEPRESSURIZE AND DRAIN SYSTEM: Depressurize, drain, and flush the piping system completely and return the knife to the fully closed position before attempting to remove the seat cartridge.

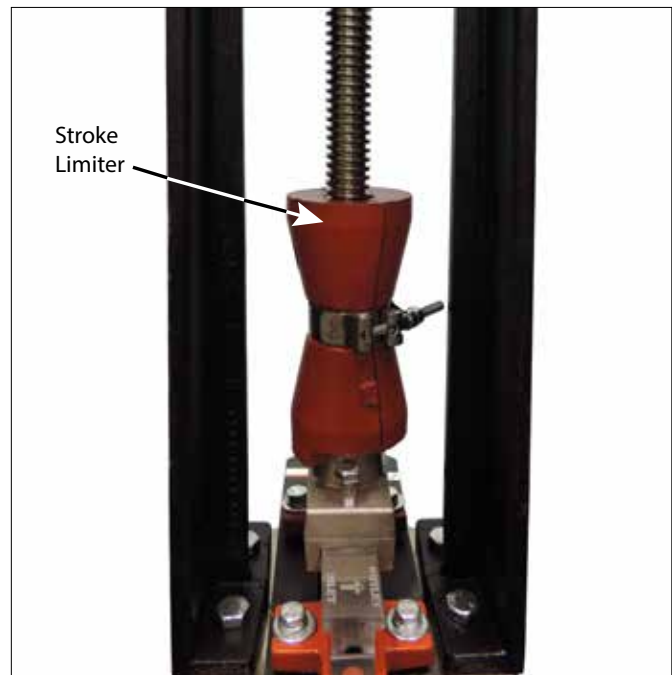

2. REMOVE STROKE LIMITER: Remove the stroke limiter in order to raise the stem completely.

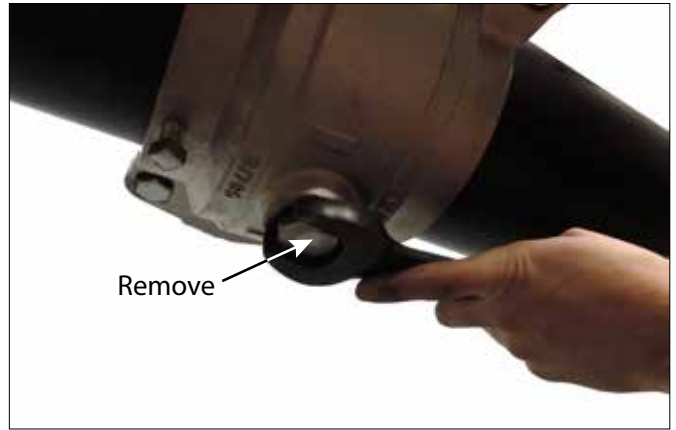

2a. Using a 7/16-inch/11 mm deep-well socket wrench, remove the nut on the T-bolt clamp and pull the clamp apart.

3. REMOVE PLUG: Using a 1 1/4-inch/32 mm wrench (for the 3 to 8" valves) or a 1 1/2-inch/38 mm wrench (for the 10 to 12" valves), remove the plug from the bottom of the valve body.



2b. Remove the T-bolt clamp and split the two halves of the stroke limiter to remove.

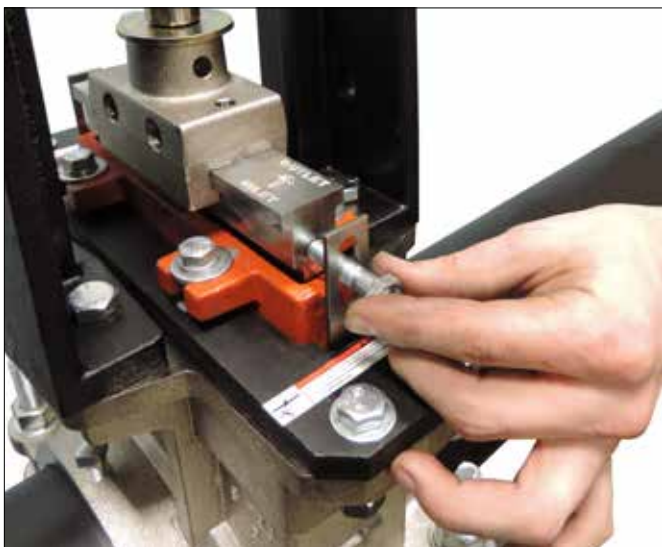
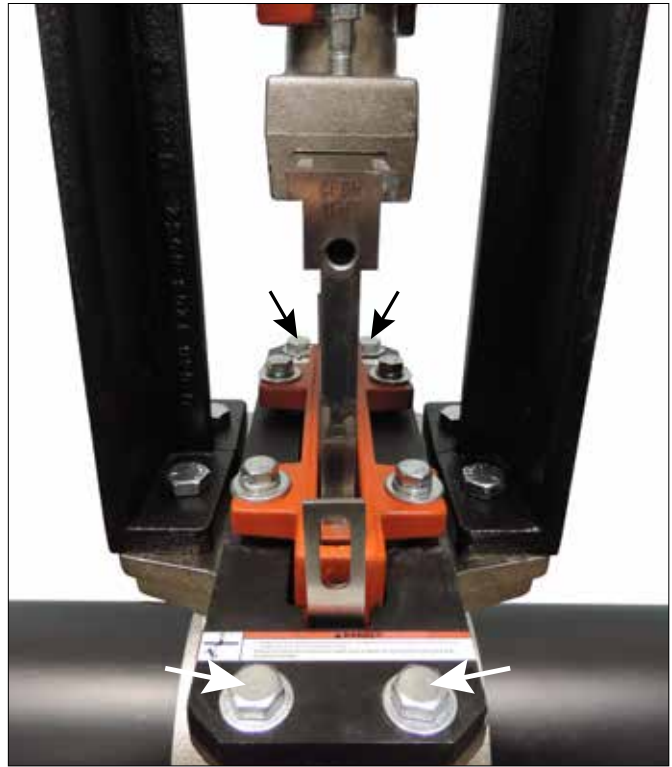

4. REMOVE AND RELOCATE GATE CONNECTOR SCREWS: Remove the two hex cap screws from the gate connector. Relocate them through the tab on each side of the seat and into the side of the knife, then finger-tighten. This is necessary to attach the seat to the knife during removal in later steps.

Valve Size	Retaining Plate Bolt Size	Retaining Plate Socket Size inches/mm
3–8"	7/16"	5/8-inch/M16 Bolt 3/4-inch/M19 Nut
10–12"	3/4"	1 1/8-inch/M29 Bolt 1 1/8-inch/M29 Nut

5. REMOVE RETAINING BOLTS: Remove the four hex cap bolts and nuts from the retaining plate, as shown above.

NOTE: Do NOT remove the packing screws. Doing so will damage the seat.



6a. OPEN VALVE: For handwheel operated valves, operate the handwheel in the “open” direction (counterclockwise) to draw the seat out from the valve body.

⚠ CAUTION

- Support the seat cartridge during actuation to prevent lateral movement. Though the valve is operable in any configuration, angled placement may allow an unsupported seat cartridge to slide out of the gate connector prematurely.

Failure to follow this instruction could result in personal injury or property damage.



6b. For pneumatically or hydraulically operated valves, actuate the valve open to draw the seat out from the valve body.

⚠ CAUTION

- Support the seat cartridge during actuation to prevent lateral movement. Though the valve is operable in any orientation, angled placement may allow an unsupported seat cartridge to slide out of the gate connector prematurely.

Failure to follow this instruction could result in personal injury or property damage.

⚠ WARNING	
	<ul style="list-style-type: none"> • Keep hands away from the edges of the knife seat while lifting it from the valve body. <p>Failure to follow this instruction could result in personal injury.</p>

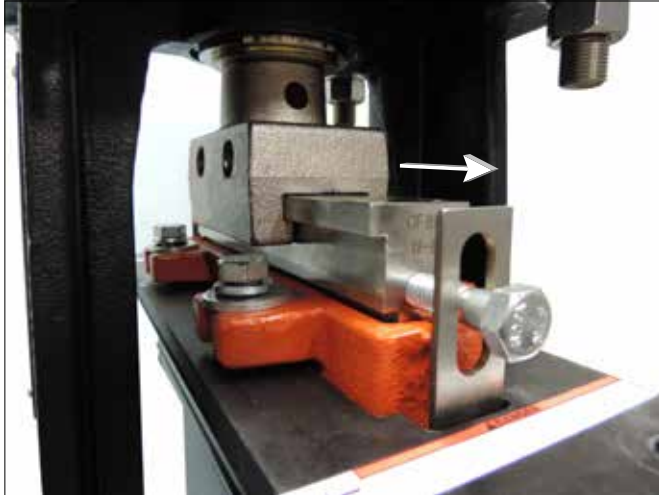

8. CLEAN VALVE: Ensure that the seat cavity and drain plug are free from debris by flushing the cavity with water. Wipe clean the sealing faces with a rag or brush.

Inspect the cavity to ensure that particles have been removed. All foreign matter should be cleared away before replacing the seat cartridge.

NOTICE
<ul style="list-style-type: none"> • Victaulic recommends having a spare replacement seat cartridge available to prevent maintenance delays.

7. REMOVE CARTRIDGE: When the seat has cleared the opening of the valve body, slide the seat cartridge out from the slot in the gate connector, as shown above. For clearance measurements, reference the E dimension in the table on page 11.

NOTE: When removing the seat cartridge, be prepared to support its weight with both hands. Refer to the table on page 11 for specific weights before attempting to remove the seat cartridge. Larger sizes may require the use of mechanical lifting equipment.

INSTALLING THE REPLACEMENT SEAT CARTRIDGE

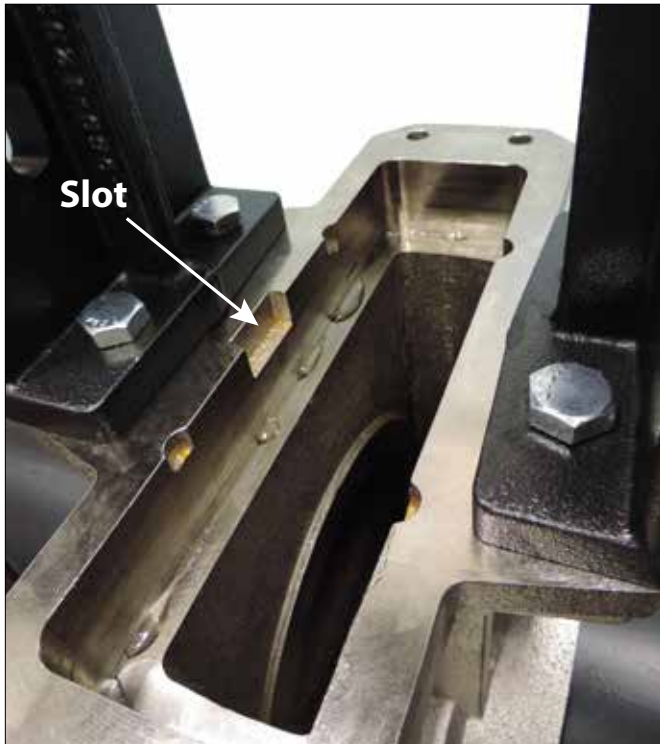
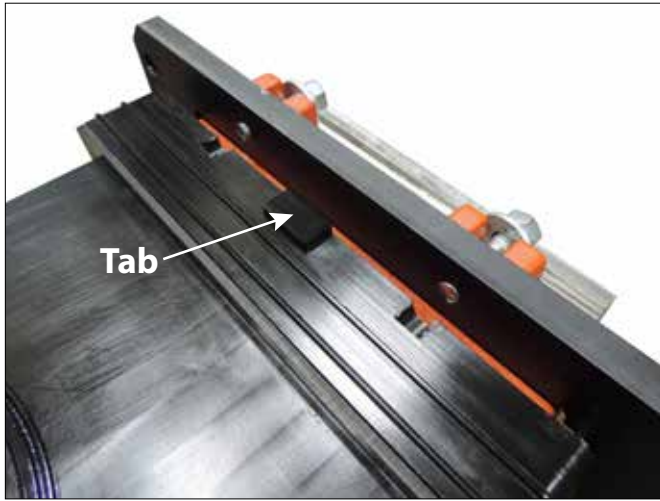

1a. PREPARE CARTRIDGE SURFACES: Apply a thin coat of Victaulic Lubricant or silicone lubricant to all exterior surfaces of the new seat cartridge. **NOTE:** The seat contains a tab that must be installed facing the slot in the valve body, as shown above.

1b. Add a thin coat of anti-seize compound to the top of the knife, as shown to the right, to aid with installation and with future removal of the cartridge.

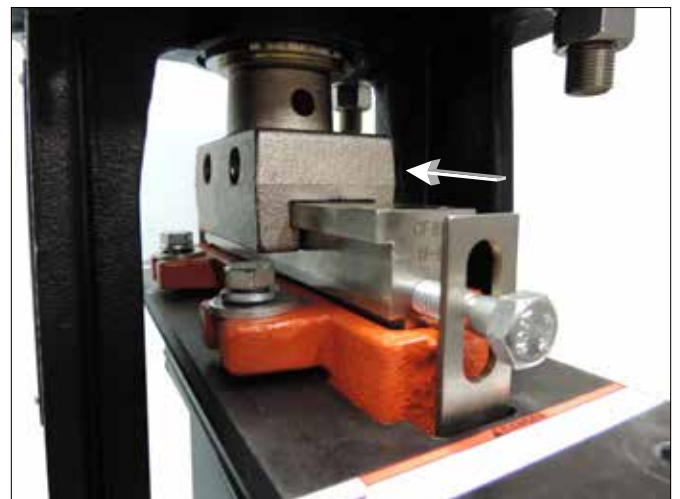
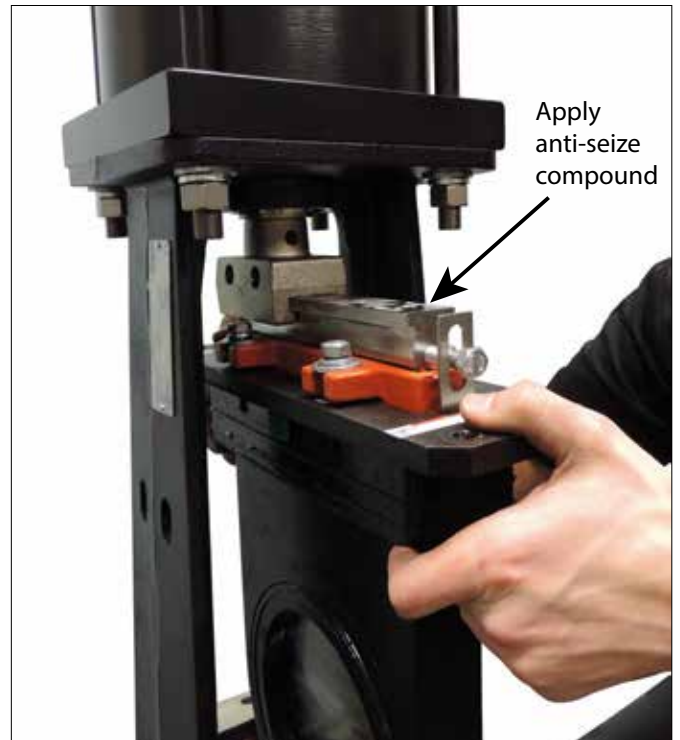

2. INSERT CARTRIDGE: Slide the replacement seat cartridge into the slot in the gate connector, as shown above.



3a. CLOSE VALVE: For handwheel operated valves, operate the handwheel slowly in the “closed” direction (clockwise) to bring the seat toward the valve body. Ensure that the tab of the seat is facing the slot in the valve body, as shown in step 1. To prevent damage to the surfaces of the seat, do not attempt to operate the handwheel at an increased rate, or by using a drill or impact gun.

3b. For pneumatically and hydraulically operated valves, actuate the valve closed to bring the seat toward the valve body.

⚠ WARNING

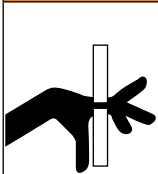

- Keep hands away from the edges of the knife seat while replacing it into the valve body.
 - Keep hands away from the seat cartridge and yoke while actuating the valve.
- Failure to follow this instruction could result in personal injury.



4. REPLACE RETAINING BOLTS: When the retaining plate is 1 inch/25 mm or less from the valve body, insert the four hex cap bolts and flat washers through the retaining plate and into the valve body, as shown above.

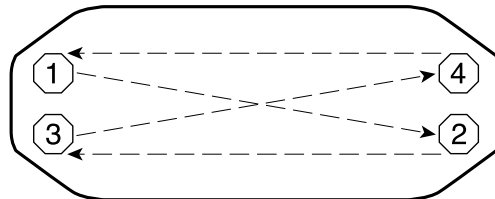

5. TIGHTEN RETAINING BOLTS: Tighten the four hex cap bolts evenly by alternating sides (as shown in the sequence above) until the lock washers are fully compressed. There should be metal-to-metal contact between the plate and the housing.

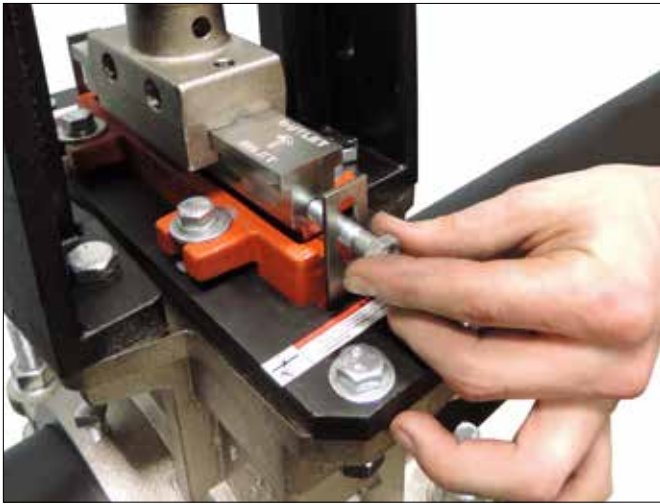

6. REMOVE AND RELOCATE GATE CONNECTOR SCREWS: Remove the two hex cap screws from the knife and relocate them to the gate connector, as shown above. Ensure that the hex cap screw is threaded down so that the head is below the washer (page 5, item 12).



7. REPLACE PLUG: Replace the plug in the bottom of the valve body, tightening the plug as directed in the chart below.

Valve Size	Plug Installation Torque Lower Nut +/- 20%
3–8"	60 ft-lbs 81.3 N·m
10–12"	100 ft-lbs 135.6 N·m



8. REPLACE STROKE LIMITER: Replace the stroke limiter on the stem by reversing the procedure for removal. Do not tighten the T-bolt clamp past 75 in-lbs.

⚠ CAUTION

- **DO NOT** attempt to place the valve back in service without replacing the stroke limiter.

Failure to follow these instructions will cause damage to the valve components. This may result in joint leakage or property damage, and could void the product warranty.



9. INSPECT GAP: Operate the handwheel (or the pneumatic or hydraulic operator) to raise the knife out of the valve body. Ensure that the gap on both sides of the knife is equal, as shown above. The hex cap screws of the packing gland can be adjusted, if necessary, to achieve an equal gap on both sides of the knife. Refer to the "Packing Adjustment" section on page 24 to review adjusting the hex cap screws.

Series 795 and 906 Installation-Ready™ Knife Gate Valves

For complete contact information, visit victaulic.com

I-795/906 8413 REV D UPDATED 6/2017 Z000795000

VICTAULIC AND INSTALLATION-READY ARE REGISTERED TRADEMARKS OR TRADEMARKS OF VICTAULIC COMPANY AND/OR ITS AFFILIATED ENTITIES IN THE UNITED STATES AND/OR OTHER COUNTRIES. © 2017 VICTAULIC COMPANY. ALL RIGHTS RESERVED.

