

Victaulic® FireLock NXT™ Preaction Trim

Series 769N



Patented

1.0 PRODUCT DESCRIPTION

Available Sizes

- 1 ½ – 8"/DN40 – DN200

Pressure Class

- Up to 300 psi/2068 kPa/21 bar

Minimum Air Pressure

- 13 psi/90 kPa/.90 bar

Actuation Options

- Series 776 Low Pressure Actuator
- Series 767 Electric/Pneumatic Actuator
- Series 798 Double-Pneumatic Actuator
- Electric Release
 - 24V DC Normally closed solenoid

Release Mechanism

- Non-Interlocked
- Single Interlocked
- Double Interlocked

Valve Configurations

- Bare
- Pre-trimmed
- Vic-Quick Riser: Pre-trimmed and includes:
 - Shut Off Valve (1 ½"/DN40: Series 728 Ball Valve, 2" – 8"/DN50 – DN200: Series 705 FireLock™ Butterfly Valve)
 - Pre-set alarm pressure switch
 - Pre-set high or low air pressure switch (Dry Pilot Only)
 - Drain Connection kit
- *Fire-Pac* Series 745 (refer to Victaulic [publication 30.23](#))

ALWAYS REFER TO ANY NOTIFICATIONS AT THE END OF THIS DOCUMENT REGARDING PRODUCT INSTALLATION, MAINTENANCE OR SUPPORT.

System No.		Location	
Submitted By		Date	

Spec Section		Paragraph	
Approved		Date	

1.0 PRODUCT DESCRIPTION (Continued)

Application:

- For use on fire protection systems only

2.0 CERTIFICATION/LISTINGS



104-1a/02

3.0 SPECIFICATIONS - MATERIAL

Body: Ductile iron conforming to ASTM A536, Grade 65-45-12.

Clapper: Aluminum bronze

Latch: Aluminum bronze

Shafts: Stainless 17-4

Clapper Seal: Peroxide cured EPDM

Bushings/Seat O-rings: Nitrile

Springs: Stainless steel

Diaphragm: Peroxide cured EPDM with fabric reinforcement

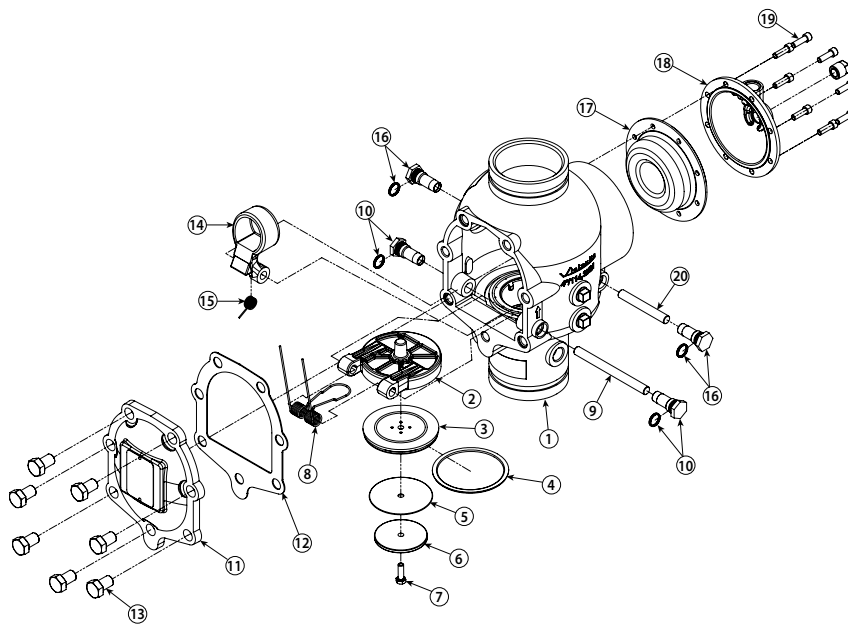

The 1½"/DN40 and 2"/DN50 valve sizes contain washers under the heads of the cover plate bolts.

Item	Description
1	Valve Body
2	Clapper
3	Clapper Seal
4	Seal Ring
5	Seal Washer
6	Seal Retaining Ring
7	Seal Assembly Bolt
8	Clapper Spring
9	Clapper Shaft
10	Clapper Shaft Bushing and O-Ring (Qty. 2)

Item	Description
11	Cover Plate
12	Cover Plate Gasket
13	Cover Plate Bolts
14	Latch
15	Latch Spring
16	Latch Spring Bushing and O-Ring (Qty. 2)
17	Diaphragm
18	Diaphragm Cover
19	Diaphragm Cover Cap Screws (Qty. 8)
20	Latch Shaft

3.0 SPECIFICATIONS - MATERIAL (Continued)

Standard Trim Package:

Non-Interlocked

- Pneumatic Release: The pneumatic release system uses a supervisory pilot line to detect a release event. When EITHER a pilot sprinkler or a system sprinkler operates, the water in the diaphragm chamber is released and the valve operates.
- Pneumatic/Electric Release: The Victaulic Electric Release System uses an electric solenoid valve, approved electric panel and a compatible detection system. The valve operates when the water in the diaphragm chamber is released when Either an electric detection or a system sprinkler operates.

Single Interlocked

- Electric Release: The Victaulic Electric Release System uses an electric solenoid valve, approved electric panel and a compatible detection system. The valve operates when the water in the diaphragm chamber is released when a release system event occurs.
- Pneumatic Release: The pneumatic release system uses a supervisory pilot line to detect a release event. Only when a pilot sprinkler operates will the water in the diaphragm chamber be released and the valve operate.

Double Interlocked

- Electric Release: The electric/pneumatic/electric release uses two electric detection devices, a fire detection device and a low pressure switch installed in the sprinkler system. The valve will actuate ONLY when BOTH a fire detection event and loss of system pressure occurs.
- Pneumatic/Electric Release: The pneumatic/electric preaction system uses both a pneumatically pressurized sprinkler system, and an electric release system, (composed of an approved solenoid valve, electric panel and an appropriate sensor). The valve will activate ONLY when there is a pressure loss in the sprinkler system AND the electric detection of a release event.
- Pneumatic/Pneumatic: The pneumatic/pneumatic system uses one Series 798 Double Pneumatic Actuator to control the Series 769N Actuated Valve. The valve will operate ONLY when there are sprinklers activated in both the pilot line and the sprinkler system.
- All required pipe nipples and fittings - standard galvanized finish
- All standard trim accessories
- All required gauges
- Series 755 Manual Release Panel

Optional Trim Package: Black Trim for Foam Systems – If the valve is intended for use in a foam system, black trim must be ordered, per NFPA requirements. Specify this requirement on the order.

3.0 SPECIFICATIONS - MATERIAL (Continued)

Optional Accessories:

Alarm Pressure Switch – Alarm pressure switches activate electrical alarms at the control panel when the 769N valve actuates and flows water into the system piping. (Note: an open sprinkler may not actuate a 769N valve but any low air alarms should operate.)

Air Supervisory Pressure Switch – Air Pressure Supervisory Switches are used to monitor low and high system air pressure and are factory pre-set.

Series 746-LPA Dry Accelerator – The Series 746-LPA Dry Accelerator is required when the Series 769N Preaction trim is installed in large systems to improve response time. Refer to Victaulic [publication 30.64](#).

Series 760 Water Motor Alarm – The Series 760 Water Motor Alarm is a mechanical device that sounds when the 769N valve actuates and is filling the system and discharging any water through any open sprinklers. Refer to Victaulic [publication 30.32](#).

Series 75B Supplemental Alarm Device – The Series 75B Supplemental Alarm Device is designed to provide a continuous alarm for systems equipped with a mechanical device. Refer to Victaulic [publication 30.33](#).

Series 75D Water Column Kit – The Series 75D Water Column Kit is designed to minimize residual water in the riser from collecting above the clapper. Refer to Victaulic [publication 30.34](#).

AutoConvert Kit – The AutoConvert Kit includes the Series 776 Low Pressure Actuator, latching solenoid, strainer, 3-in-1 strainer/check/restrictor assembly, air pressure gauge and assembly trim. It is ordered separately and can be installed on any FireLock NXT™ Single Interlock or Double Interlock Preaction system that includes a solenoid.

Air Supply System – The air supply system contains all components for establishing and maintaining air in the system. The compressor ball valves, and required trim are included in the air supply system.

Air Compressor Refer to Victaulic [publication 30.22](#).

Air Maintenance Trim Assembly Refer to Victaulic [publication 30.35](#).

Fire Alarm Control Panels

Drain Connection Kit

Redundant Electric Solenoid made by alternate manufacturer required by LPCB approval.

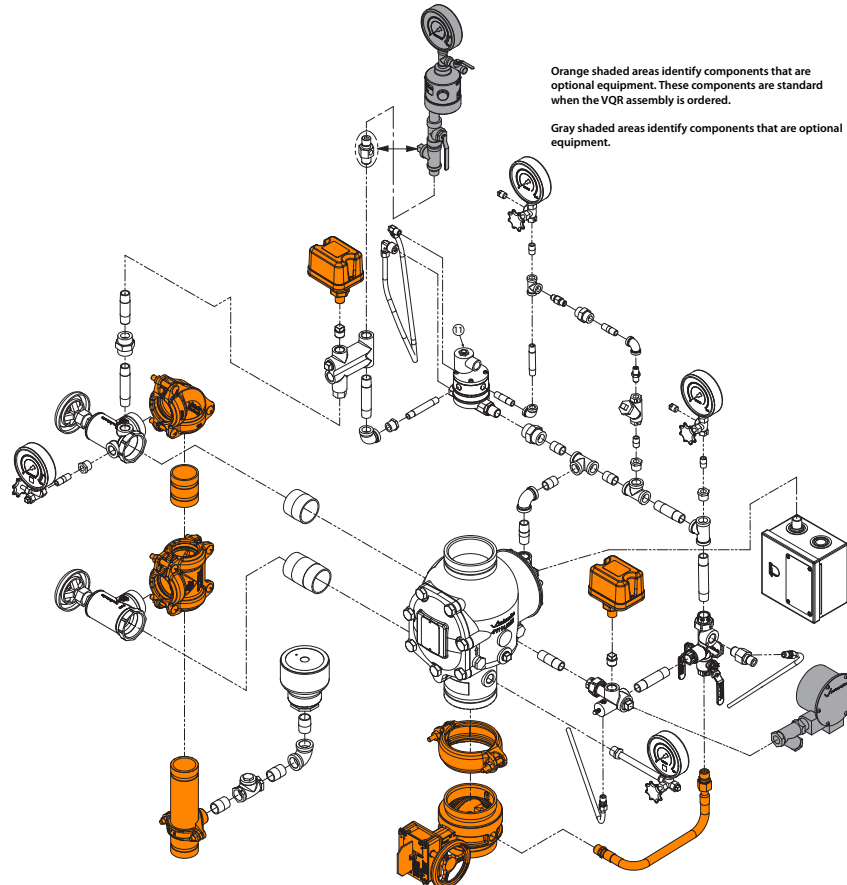

4.0 DIMENSIONS

A 4"/DN100 valve with single-interlocked pneumatic release preaction trim is shown below

1 ½ – 2"/DN40 – DN50 configurations contain ¾"/19 mm drain valves

2 ½ – 3"/DN65 – DN80 and 73.0 mm configurations contain 1 ¼"/31 mm drain valves

4 – 8"/DN100 – DN200 configurations contain 2"/50 mm drain valves

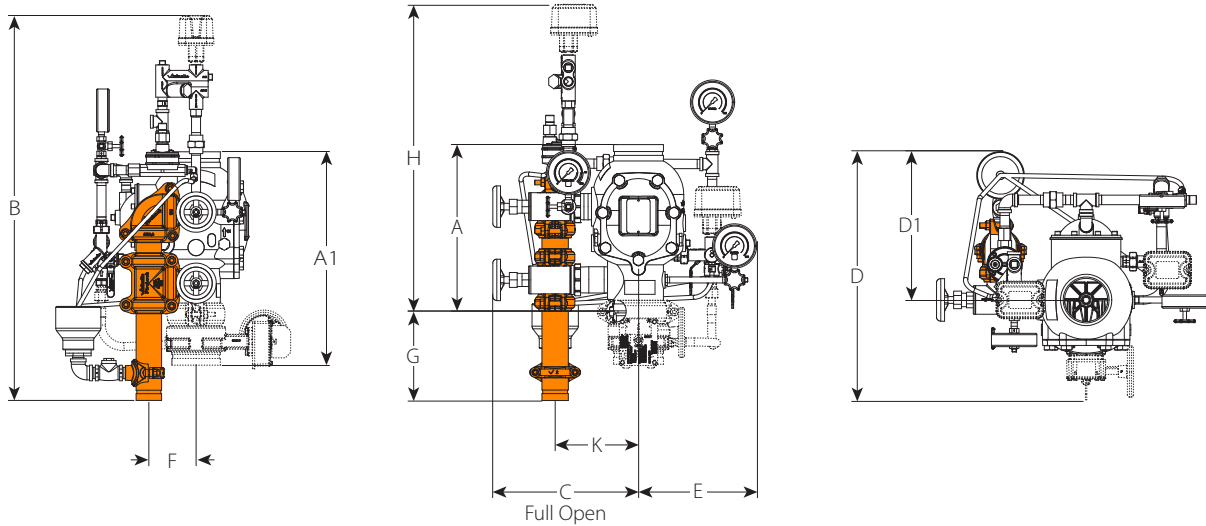

Size		Dimensions											Weight Each	
Nominal	Actual Outside Diameter	A ¹	A1 ²	B ³	C	D ⁴	D1 ⁴	E	F	G	H	K	Without Trim	With Trim
inches DN	inches mm	inches mm	inches mm	inches mm	inches mm	inches mm	inches mm	inches mm	inches mm	inches mm	inches mm	inches mm	lb kg	lb kg
1 ½ DN40	1.900 48.3	9.00 229	16.37 416	34.25 870	9.25 235	16.25 413	11.00 279	9.00 229	3.25 83	10.25 260	24.00 610	6.00 152	16.7 7.6	43.0 19.5
2 DN50	2.375 60.3	9.00 229	13.83 351	34.25 870	9.25 235	17.50 445	11.00 279	9.00 229	3.25 83	10.25 260	24.00 610	6.00 152	17.0 7.7	43.0 19.5
2 ½	2.875 73.0	12.61 320	16.51 419	35.75 908	11.25 286	20.00 508	12.50 318	9.50 241	4.00 102	9.75 248	26.00 660	6.50 165	41.0 18.7	65.0 29.5
DN65	3.000 76.1	12.61 320	16.51 419	35.75 908	11.25 286	20.00 508	12.50 318	9.50 241	4.00 102	9.75 248	26.00 660	6.50 165	41.0 18.7	65.0 29.5
3 DN80	3.500 88.9	12.61 320	16.51 419	35.75 908	11.25 286	20.00 508	12.50 318	9.50 241	4.00 102	9.75 248	26.00 660	6.50 165	41.0 18.7	65.0 29.5
4 DN100	4.500 114.3	15.03 382	19.85 504	36.50 927	13.50 343	22.25 565	13.50 343	11.00 279	4.75 121	8.50 216	28.00 711	8.00 203	59.0 26.7	95.0 43.0
	6.500 165.1	16.00 406	22.13 562	36.75 933	14.00 356	24.50 622	13.25 337	11.00 279	4.50 114	8.25 210	28.50 724	8.25 210	80.0 36.2	116.0 52.6
6 DN150	6.625 168.3	16.00 406	22.13 562	36.75 933	14.00 356	24.50 622	13.25 337	11.00 279	4.50 114	8.25 210	28.50 724	8.25 210	80.0 36.2	116.0 52.6
8 DN200	8.625 219.1	17.50 445	23.02 585	39.50 1003	14.75 375	27.00 686	13.50 343	12.25 311	4.75 121	8.25 210	31.25 794	9.25 235	122.0 55.3	158.0 71.6

¹ The "A" dimension is the actual takeout dimension of the valve body.

² The "A1" dimension is the actual takeout dimension of the valve body with water supply main control valve.

³ For systems with the optional Series 746-LPA Dry Accelerator, add 11.50 inches/292 mm to the "B" dimension to account for the additional height.

⁴ The "D" and "D1" dimensions are not fixed measurements. The drip cup can be rotated to provide more clearance at the back of the trim.

NOTES

- The drawings shown above reflect the single-interlocked pneumatic release trim with Series 776 Low-Pressure Actuator. In addition, these dimensions can be applied to all other trim configurations featured within this manual.
- Components shown as dotted lines denote optional equipment.
- The recommended drain connection kit (shaded in orange) is for reference and takeout dimensions. This drain connection comes standard when the VQR assembly is ordered.

4.1 DIMENSIONS

A 4"/DN100 valve with electric autoconvert dry release preaction trim is shown below
 1 ½ – 2"/DN40 – DN50 configurations contain ¾"/19 mm drain valves
 2 ½ – 3"/DN65 – DN80 and 73.0 mm configurations contain 1 ¼"/31 mm drain valves
 4 – 8"/DN100 – DN200 configurations contain 2"/50 mm drain valves

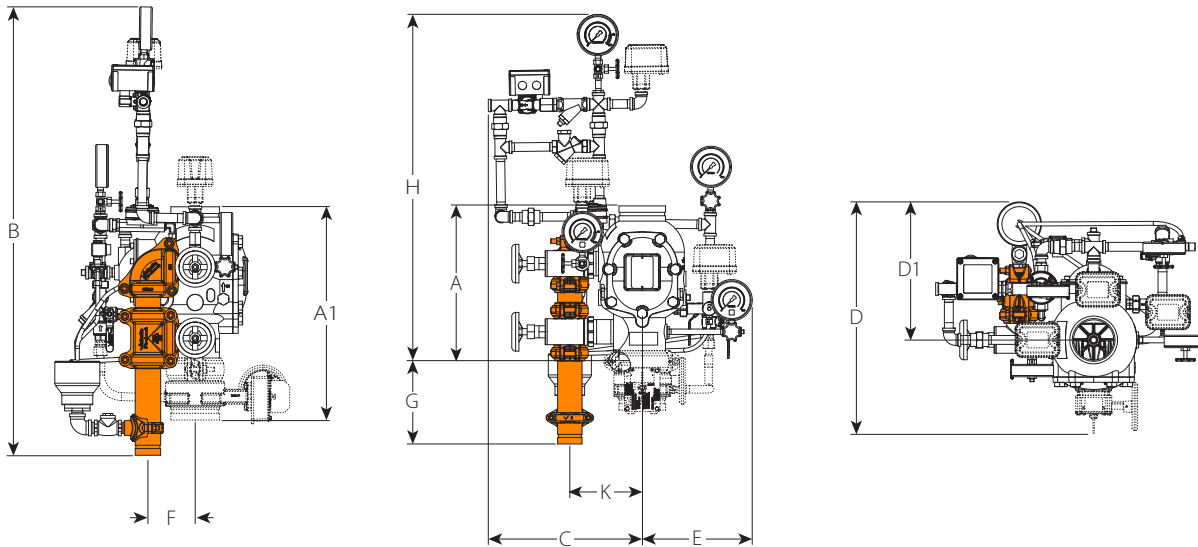

Size		Dimensions											Weight Each	
Nominal	Actual Outside Diameter	A ¹	A1 ²	B ³	C	D	D1	E	F	G	H	K	Without Trim	With Trim
inches	inches	inches	inches	inches	inches	inches	inches	inches	inches	inches	inches	inches	lb	lb
DN	mm	mm	mm	mm	mm	mm	mm	mm	mm	mm	mm	mm	kg	kg
1 ½	1.900	9.00	16.37	38.00	15.50	25.00	16.25	9.50	3.25	10.25	27.75	6.00	16.7	43.0
DN40	48.3	229	416	965	394	635	413	241	83	260	705	152	7.6	19.5
2	2.375	9.00	13.83	38.00	15.50	25.00	16.25	9.50	3.25	10.25	27.75	6.00	17.0	43.0
DN50	60.3	229	351	965	394	635	413	241	83	260	705	152	7.7	19.5
2 ½	2.875	12.61	16.51	40.75	16.00	24.00	15.00	9.50	4.00	9.75	31.00	6.50	41.0	65.0
	73.0	320	419	1035	406	610	381	241	102	248	787	165	18.7	29.5
DN65	3.000	12.61	16.51	40.75	16.00	24.00	15.00	9.50	4.00	9.75	31.00	6.50	41.0	65.0
	76.1	320	419	1035	406	610	381	241	102	248	787	165	18.7	29.5
3	3.500	12.61	16.51	40.75	16.00	24.00	15.00	9.50	4.00	9.75	31.00	6.50	41.0	65.0
DN80	88.9	320	419	1035	406	610	381	241	102	248	787	165	18.7	29.5
4	4.500	15.03	19.85	42.50	15.25	22.50	14.75	11.00	4.75	8.50	34.00	7.50	59.0	95.0
DN100	114.3	382	504	1080	387	572	375	279	121	216	864	191	26.7	43.0
	6.500	16.00	22.13	42.50	15.25	26.00	15.25	11.00	4.50	8.25	34.25	8.25	80.0	116.0
	165.1	406	562	1080	387	660	387	279	114	210	870	210	36.2	52.6
6	6.625	16.00	22.13	42.50	15.25	26.00	15.25	11.00	4.50	8.25	34.25	8.25	80.0	116.0
DN150	168.3	406	562	1080	387	660	387	279	114	210	870	210	36.2	52.6
8	8.625	17.50	23.02	44.50	18.50	30.00	16.00	12.25	4.75	8.25	36.25	9.25	122.0	158.0
DN200	219.1	445	585	1130	470	762	406	311	121	210	921	235	55.3	71.6

¹ The “A” dimension is the actual takeout dimension of the valve body.

² The “A1” dimension is the actual takeout dimension of the valve body with water supply main control valve.

³ For systems with the optional Series 746-LPA Dry Accelerator, add 9.50 inches/241 mm to the “B” dimension to account for the additional height.

NOTES

- The drawings shown above reflect the electric AutoConvert dry release trim. In addition, these dimensions can be applied to the redundant solenoid valve configuration.
- Components shown as dotted lines denote optional equipment.
- The recommended drain connection kit (shaded in orange) is for reference and takeout dimensions. This drain connection comes standard when the VQR assembly is ordered.

4.2 DIMENSIONS

A 4"/DN100 valve with double-interlocked electric/pneumatic autoconvert dry release preaction trim is shown below

1 ½ – 2"/DN40 – DN50 configurations contain ¾"/19 mm drain valves

2 ½ – 3"/DN65 – DN80 and 73.0 mm configurations contain 1 ¼"/31 mm drain valves

4 – 8"/DN100 – DN200 configurations contain 2"/50 mm drain valves

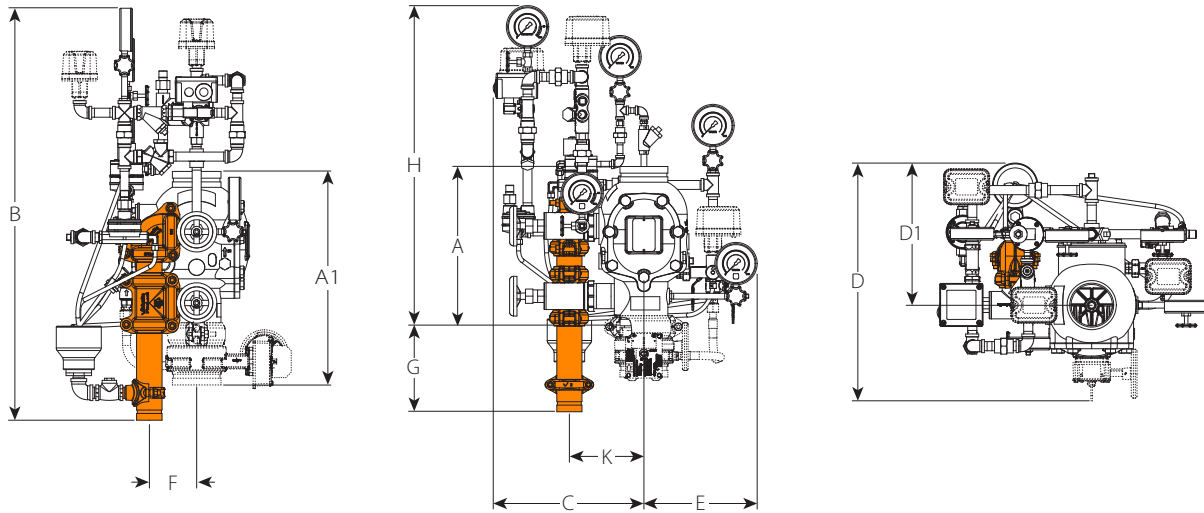

Size		Dimensions											Weight Each	
Nominal inches DN	Actual Outside Diameter inches mm	A ¹ inches mm	A1 ² inches mm	B ³ inches mm	C inches mm	D inches mm	D1 inches mm	E inches mm	F inches mm	G inches mm	H inches mm	K inches mm	Without Trim lb kg	With Trim lb kg
1 ½ DN40	1.900	9.00	16.37	36.50	17.50	20.25	13.50	9.00	3.25	10.25	26.25	6.00	16.7	43.0
	48.3	229	416	927	445	514	343	229	83	260	667	152	7.6	19.5
2 DN50	2.375	9.00	13.83	36.50	17.50	20.25	13.50	9.00	3.25	10.25	26.25	6.00	17.0	43.0
	60.3	229	351	927	445	514	343	229	83	260	667	152	7.7	19.5
2 ½	2.875	12.61	16.51	38.25	17.50	20.75	13.50	9.50	4.00	9.75	28.50	6.50	41.0	65.0
	73.0	320	419	972	445	527	343	241	102	248	724	165	18.7	29.5
DN65	3.000	12.61	16.51	38.25	17.50	20.75	13.50	9.50	4.00	9.75	28.50	6.50	41.0	65.0
	76.1	320	419	972	445	527	343	241	102	248	724	165	18.7	29.5
3 DN80	3.500	12.61	16.51	38.25	17.50	20.75	13.50	9.50	4.00	9.75	28.50	6.50	41.0	65.0
	88.9	320	419	972	445	527	343	241	102	248	724	165	18.7	29.5
4 DN100	4.500	15.03	19.85	39.00	14.25	20.25	12.50	11.00	4.75	8.50	30.50	7.50	59.0	95.0
	114.3	382	504	991	362	514	318	279	121	216	775	191	26.7	43.0
6 DN150	6.500	16.00	22.13	40.25	15.00	20.75	13.00	11.00	4.50	8.50	31.75	8.25	80.0	116.0
	165.1	406	562	1022	381	527	330	279	114	216	806	210	36.2	52.6
8 DN200	8.625	17.50	23.02	41.75	16.00	21.50	13.50	12.25	4.75	8.25	33.50	9.25	122.0	158.0
	219.1	445	585	1060	406	546	343	311	121	210	851	235	55.3	71.6

¹ The "A" dimension is the actual takeout dimension of the valve body.

² The "A1" dimension is the actual takeout dimension of the valve body with water supply main control valve.

³ For systems with the optional Series 746-LPA Dry Accelerator, add 9.50 inches/241 mm to the "B" dimension to account for the additional height

NOTES

- The drawings shown above reflect the electric AutoConvert dry release trim. In addition, these dimensions can be applied to the redundant solenoid valve configuration.
- Components shown as dotted lines denote optional equipment.
- The recommended drain connection kit (shaded in orange) is for reference and takeout dimensions. This drain connection comes standard when the VQR assembly is ordered.

4.3 DIMENSIONS

A 4"/DN100 valve with double-interlocked pneumatic/pneumatic release preaction trim is shown below

1 ½ – 2"/DN40 – DN50 configurations contain ¾"/19 mm drain valves

2 ½ – 3"/DN65 – DN80 and 73.0 mm configurations contain 1 ¼"/31 mm drain valves

4 – 8"/DN100 – DN200 configurations contain 2"/50 mm drain valves

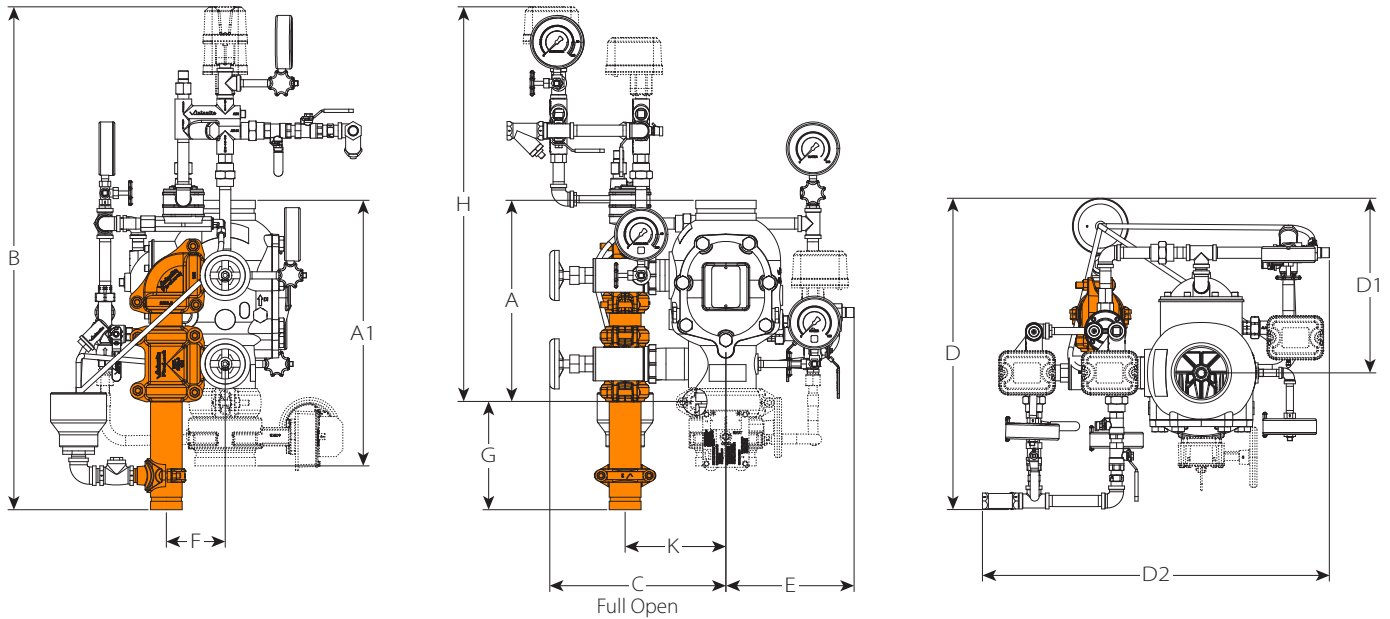

Size		Dimensions												Weight Each	
Nominal inches DN	Actual Outside Diameter inches mm	A ¹ inches mm	A1 ² inches mm	B ³ inches mm	C inches mm	D inches mm	D1 ⁴ inches mm	D2 ⁴ inches mm	E inches mm	F inches mm	G inches mm	H inches mm	K inches mm	Without Trim lb kg	With Trim lb kg
1 ½ DN40	1.900 48.3	9.00 229	16.37 416	36.00 914	9.25 235	21.25 540	11.00 279	23.50 597	9.25 235	3.25 83	10.25 260	25.75 654	6.00 152	16.7 7.6	43.0 19.5
2 DN50	2.375 60.3	9.00 229	13.83 351	36.00 914	9.25 235	21.25 540	11.00 279	23.50 597	9.25 235	3.25 83	10.25 260	25.75 654	6.00 152	17.0 7.7	43.0 19.5
2 ½	2.875 73.0	12.61 320	16.51 419	37.75 959	11.25 286	22.50 572	12.50 318	24.75 629	9.50 241	4.00 102	9.75 248	28.00 711	6.50 165	41.0 18.7	65.0 29.5
DN65	3.000 76.1	12.61 320	16.51 419	37.75 959	11.25 286	22.50 572	12.50 318	24.75 629	9.50 241	4.00 102	9.75 248	28.00 711	6.50 165	41.0 18.7	65.0 29.5
3 DN80	3.500 88.9	12.61 320	16.51 419	37.75 959	11.25 286	22.50 572	12.50 318	24.75 629	9.50 241	4.00 102	9.75 248	28.00 711	6.50 165	41.0 18.7	65.0 29.5
4 DN100	4.500 114.3	15.03 382	19.85 504	38.50 978	13.50 343	23.75 603	13.50 343	26.25 667	10.00 254	4.75 121	8.50 216	30.00 762	8.00 203	59.0 26.7	111.0 50.3
	6.500 165.1	16.00 406	22.13 562	39.25 997	14.00 356	24.50 622	13.25 337	27.75 705	11.00 279	4.50 114	8.25 210	31.00 787	8.25 210	80.0 36.2	132.0 59.8
6 DN150	6.625 168.3	16.00 406	22.13 562	39.25 997	14.00 356	24.50 622	13.25 337	27.75 705	11.00 279	4.50 114	8.25 210	31.00 787	8.25 210	80.0 36.2	132.0 59.8
8 DN200	8.625 219.1	17.50 445	23.02 585	41.25 1048	14.75 375	27.00 686	13.50 343	29.75 756	12.25 311	4.75 121	8.25 210	33.00 838	9.25 235	122.0 55.3	174.0 78.9

¹ The "A" dimension is the actual takeout dimension of the valve body.

² The "A1" dimension is the actual takeout dimension of the valve body with water supply main control valve.

³ For systems with optional Series 746-LPA Dry Accelerators, add 11.50 inches/292 mm to the "B" dimension to account for the additional height.

⁴ The "D" and "D1" dimensions are not fixed measurements. The drip cup can be rotated to provide more clearance at the back of the trim.

NOTES

- Components shown as dotted lines denote optional equipment.
- The recommended drain connection kit (shaded in orange) is for reference and takeout dimensions. This drain connection comes standard when the VQR assembly is ordered.

5.0 PERFORMANCE

Hydraulic Friction Loss

The chart below expresses the flow of water at 65°F/18°C through an open valve.

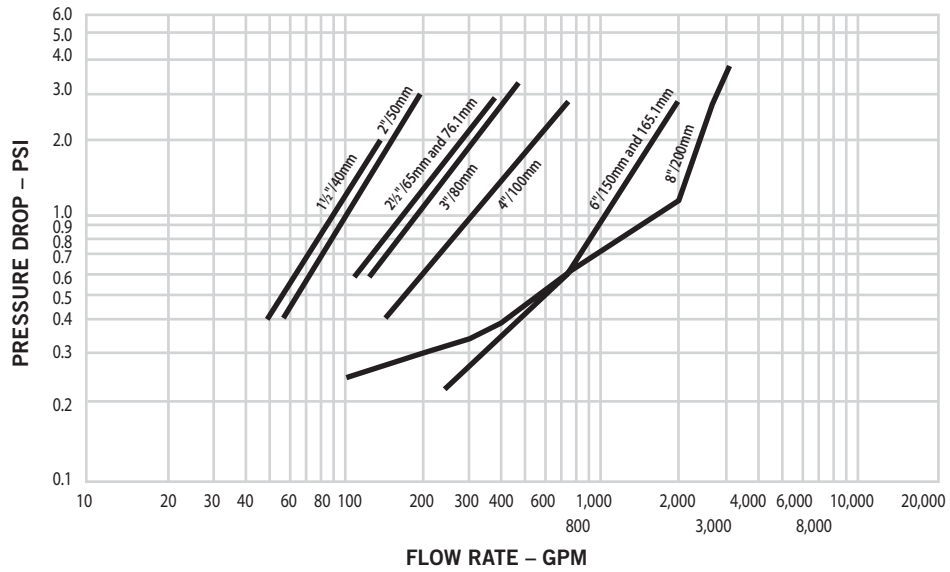

Frictional Resistance

The chart below expresses the frictional resistance of Victaulic Series 769N FireLock NXT™.

Preaction Trim in equivalent feet of straight pipe.

Size		Equivalent Length of Pipe feet meters
Nominal inches DN	Actual Outside Diameter inches mm	
1 1/2 DN40	1.900 48.3	3.00 0.914
2 DN50	2.375 60.3	9.00 2.743
2 1/2	2.875 73.0	8.00 2.438
DN65	3.000 76.1	8.00 2.439
3 DN80	3.500 88.9	17.00 5.182
4 DN100	4.500 114.3	21.00 6.401
	6.500 165.1	22.00 6.706
6 DN150	6.625 168.3	22.00 6.706
8 DN200	8.625 219.1	50.00 15.240

Cv Values:

Cv values for flow of water at +60°F/+16°C through a fully open valve are shown in the table below.

Formulas for Cv values

$$\Delta P = Q^2 / C_v^2$$

$$Q = C_v \times \sqrt{\Delta P}$$

Where:

Flow Coefficient	Cv
Q (Flow)	GPM
ΔP (Pressure Drop)	psi

Size		Full Open
Nominal inches DN	Actual Outside Diameter inches mm	Flow Coefficient Cv Kv
1 1/2 DN40	1.900 48.3	60 52.0
2 DN50	2.375 60.3	110 95.0
2 1/2	2.875 73.0	180 156.0
DN65	3.000 76.1	180 156.0
3 DN80	3.500 88.9	200 173.0
4 DN100	4.500 114.3	350 302.8
	6.500 165.1	1000 865.0
6 DN150	6.625 168.3	1000 865.0
8 DN200	8.625 219.1	1500 1297.5

5.0 PERFORMANCE (Continued)

Air Supply Requirements

- Minimum: 13 psi/90 kPa/.9 bar regardless of the system water pressure
- Maximum Recommended: 18 psi/124 kPa/1.24 bar
- Sizing the compressor:
 - Engineer/system designer is responsible
 - Entire system must be charged to the required air pressure within 30 minutes to meet NFPA requirements
 - An oversized compressor will slow down or possibly prevent valve operation
 - Compressor filling the system too fast:
 - May be necessary to restrict the air supply
 - Ensure that air exhausted from an open sprinkler or manual release valve is not replaced by the air supply system as fast as it is exhausted
- Compressor Requirements
 - Base or Riser Mounted Compressors:
 - “On” or “low” pressure setting: 13 psi/90 kPa/.9 bar
 - “Off” or “high” pressure setting: 18 psi/124 kPa/1.24 bar
 - Victaulic Series 7C7 riser mounted and pre-set for pressure requirements (refer to Victaulic [publication 30.22](#)).
 - If the compressor is not equipped with a pressure switch, the Series 757P Air Maintenance Trim Assembly with pressure switch should be installed (refer to Victaulic [publication 30.36](#)).
 - Shop Air or Tank-Mounted Air Compressors:
 - Series 757 Regulated Air Maintenance Trim Assembly should be installed (refer to Victaulic [publication 30.35](#))
 - 13 psi/90 kPa/.9 bar should be used as the set point for the air regulator
 - The compressor cut-in (turn-on) pressure setting should be at least 5 psi/34kPa/34 bar above the set point of the air regulator.
 - Exploded View Trim: Series 757 Regulated Air Maintenance Trim Assembly (refer to Victaulic [publication 30.35](#))
- Compressor Requirements and settings for systems installed with Series 746 or Series 746-LPA dry accelerators
 - A tank-mounted air compressor with a Series 757 Regulated AMTA must be used to supply air to system installed with a Series 746 or Series 746-LPA Dry Accelerator.
 - In the event a compressor becomes inoperative, a properly sized tank-mounted air compressor provides the greatest protection, since air can be supplied continuously to the sprinkler system for an extended time period.

Electrical Release Requirements



- Verify that an approved control panel is installed for proper system operation.

5.0 PERFORMANCE (Continued)

Autoconvert Requirements

- System must be installed in conjunction with a Notifier RP-2001 family panel, System Sensor PDRP-2001, or a Potter 4410RC panel to be in compliance with FM Approvals.
- AutoConvert Trim: In the event of an AC power loss, the AutoConvert module latches from Closed to Open with a quick electrical pulse. To stay open, no further current draw is required as would be needed in a normally open solenoid. This opened pathway allows the included Series 776 Low Pressure Actuator to operate as a dry actuator, putting the preaction system into a Non-Interlocked condition. In this case, an electrical release from the FACP and an air loss in the system or the system air loss would allow the Series 769N valve to actuate, filling the pipe with water. Upon an AC power return, the Auto-Convert module senses the restoration and latches the path from the Series 776 Low Pressure Actuator closed, returning the preaction valve to its standard release method.

6.0 NOTIFICATIONS

 WARNING	
	<ul style="list-style-type: none">• Read and understand all instructions before attempting to install any Victaulic products.• Always verify that the piping system has been completely depressurized and drained immediately prior to installation, removal, adjustment, or maintenance of any Victaulic products.• Wear safety glasses, hardhat, and foot protection. <p>Failure to follow these instructions could result in death or serious personal injury and property damage.</p>
<ul style="list-style-type: none">• These products shall be used only in fire protection systems that are designed and installed in accordance with current, applicable National Fire Protection Association (NFPA 13, 13D, 13R, etc.) standards, or equivalent standards, and in accordance with applicable building and fire codes. These standards and codes contain important information regarding protection of systems from freezing temperatures, corrosion, mechanical damage, etc.• The installer shall understand the use of this product and why it was specified for the particular application.• The installer shall understand common industry safety standards and potential consequences of improper product installation.• It is the system designer's responsibility to verify suitability of materials for use with the intended fluid media within the piping system and external environment.• The material specifier shall evaluate the effect of chemical composition, pH level, operating temperature, chloride level, oxygen level, and flow rate on materials to confirm system life will be acceptable for the intended service. <p>Failure to follow installation requirements and local and national codes and standards could compromise system integrity or cause system failure, resulting in death or serious personal injury and property damage.</p>	

7.0 REFERENCE MATERIALS

- [30.22: FireLock™ Compressor Package Series 7C7](#)
- [30.23: FireLock™ Fire-Pac Series 745](#)
- [30.32: FireLock™ Water Motor Alarm Series 760](#)
- [30.33: Supplemental Alarm Kit Series 75B](#)
- [30.34: Automatic Water Column Drain Kit for FireLock NXT™ Valves Series 75D](#)
- [30.35: FireLock™ Air Maintenance Trim Assembly Series 757](#)
- [30.36: FireLock™ Air Maintenance Trim Assembly Series 757P](#)
- [30.41: FireLock™ Manual Pull Station Series 755](#)
- [30.61: FireLock™ Double-Pneumatic Actuator Series 798](#)
- [30.62: FireLock™ Low Pressure Actuator Series 767](#)
- [30.63: FireLock™ Electric Solenoid Series 753E](#)
- [30.64: FireLock™ Dry Accelerator Series 746-LPA](#)
- [30.65: FireLock™ Low Pressure Actuator Series 776](#)
- [30.84 FireLock NXT™ AutoConvert Trim Assembly for Preaction Devices](#)
- [I-769N.Preaction](#)
- [I-769N.Preaction/DPA](#)
- [I-769N.Preaction/EPA](#)
- [I-769N.Preaction/AC-Elec](#)
- [I-769N.Preaction/AC-EP](#)

Scan for reference documents.

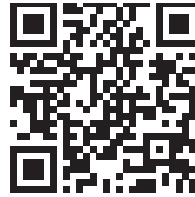

User Responsibility for Product Selection and Suitability

Each user bears final responsibility for making a determination as to the suitability of Victaulic products for a particular end-use application, in accordance with industry standards and project specifications, as well as Victaulic performance, maintenance, safety, and warning instructions. Nothing in this or any other document, nor any verbal recommendation, advice, or opinion from any Victaulic employee, shall be deemed to alter, vary, supersede, or waive any provision of Victaulic Company's standard conditions of sale, installation guide, or this disclaimer.

Intellectual Property Rights

No statement contained herein concerning a possible or suggested use of any material, product, service, or design is intended, or should be construed, to grant any license under any patent or other intellectual property right of Victaulic or any of its subsidiaries or affiliates covering such use or design, or as a recommendation for the use of such material, product, service, or design in the infringement of any patent or other intellectual property right. The terms "Patented" or "Patent Pending" refer to design or utility patents or patent applications for articles and/or methods of use in the United States and/or other countries.

Note

This product shall be manufactured by Victaulic or to Victaulic specifications. All products to be installed in accordance with current Victaulic installation/assembly instructions. Victaulic reserves the right to change product specifications, designs and standard equipment without notice and without incurring obligations.

Installation

Reference should always be made to the Victaulic installation handbook or installation instructions of the product you are installing. Handbooks are included with each shipment of Victaulic products, providing complete installation and assembly data, and are available in PDF format on our website at www.victaulic.com.

Warranty

Refer to the Warranty section of the current Price List or contact Victaulic for details.

Trademarks

Victaulic and all other Victaulic marks are the trademarks or registered trademarks of Victaulic Company, and/or its affiliated entities, in the U.S. and/or other countries.