

Series 756 FireLock™ Dry Valve

Hang these instructions on the installed valve for easy future reference.



WARNING



Failure to follow instructions and warnings can result in serious personal injury, property damage, and/or product failure.

- Read and understand all installation instructions before attempting to install any Victaulic piping products.
- Wear safety glasses, hardhat, and foot protection.

If you need additional copies of any literature, or if you have any questions about the safe installation and operation of this product, contact Victaulic Company, P.O. Box 31, Easton, PA 18044-0031, USA, Telephone: 1-800-PICK VIC, e-mail: pickvic@victaulic.com.

TABLE OF CONTENTS

Hazard Identification	1	External Inspection	14
Installer Safety Instructions	2	Weekly Inspection	14
Introduction	3	Monthly Inspection	14
Trim Dimensions	3	Required Tests	14
Exploded View Drawing - Trim Components	4	Main Drain Test	14
Exploded View Drawing - Internal Valve Components	5	Water Flow Alarm Test	15
Series 756 Dry Valve with Series 753-A Dry Actuator – Trim Assembly Drawing Numbers	5	Water Level and Low-Air Alarm Tests	17
Section View Drawing and Description – Series 753-A Dry Actuator	6	Trip Tests	18
Section View Drawing and Description – Series 746 Dry Accelerator	6	Partial Flow Test	18
Compressor and Air Maintenance Trim Requirements	7	Full Flow Test	23
Air Supply Design	7	Required Internal Inspection	24
Proper Air Supplies for Series 756 Dry Valves Used with Series 753-A Dry Actuators Only	8	Maintenance	26
Proper Air Supplies for Series 756 Dry Valves Used with Series 753-A Dry Actuators and Series 746 Dry Accelerators	8	Removing and Replacing Clapper Seal	26
Important Installation Information	8	Removing and Replacing Clapper Assembly	28
Valve/Trim Installation	9	Installing Cover Plate Gasket and Cover Plate	29
Important Settings	9	Removing and Replacing Piston Assembly	30
Hydrostatic Testing	9	Troubleshooting – Series 753-A Dry Actuator	31
Placing the System in Service	10	Troubleshooting – Series 746 Dry Accelerator	31
		Troubleshooting – System	31
		Warranty	32
		Facilities Locations	B/C

HAZARD IDENTIFICATION

Definitions for identifying the various hazard levels are provided below.



This safety alert symbol indicates important safety messages. When you see this symbol, be alert to the possibility of personal injury. Carefully read and fully understand the message that follows.

WARNING

The use of the word “WARNING” identifies the presence of hazards or unsafe practices that could result in death or serious personal injury if instructions, including recommended precautions, are not followed.

CAUTION

The use of the word “CAUTION” identifies possible hazards or unsafe practices that could result in personal injury and product or property damage if instructions, including recommended precautions, are not followed.

NOTICE

The use of the word “NOTICE” identifies special instructions that are important but not related to hazards.

INSTALLER SAFETY INSTRUCTIONS

⚠ WARNING	
	<ul style="list-style-type: none">• An experienced, trained installer must install this product in accordance with all instructions. These instructions contain important information. <p>Failure to follow these instructions could result in serious personal injury, property damage, and/or product failure.</p> <p>If you need additional copies of any literature, or if you have any questions about the safe installation and operation of this valve, contact Victaulic Company, P.O. Box 31, Easton, PA 18044-0031 USA, Telephone: 1-800-PICK Vic, e-mail: pickvic@victaulic.com.</p>

⚠ WARNING	
	<ul style="list-style-type: none">• Depressurize and drain piping systems before attempting to install or remove any Victaulic piping products. <p>Failure to follow this instruction could result in serious personal injury, property damage, and/or product damage.</p>

GENERAL

1. **Read and understand all instructions before proceeding with the installation, maintenance, and testing of this Victaulic fire protection device.**
2. **Use only recommended accessories.** Use of improper accessories or equipment could result in improper system operation.
3. **Avoid dangerous environments.** If using electrically powered tools for installation, make sure the area is moisture-free. Keep work areas well lit. Allow enough space for installing the device, trim, and accessories safely and efficiently.
4. **Prevent back injury.** Larger and pre-trimmed valves are heavier and may require more than one person or mechanical lifting equipment to position and install the assembly properly. Always practice proper lifting techniques.
5. **Inspect the shipment.** Make sure all components are included with the shipment and that all necessary tools are available for proper installation.
6. **Wear safety glasses, hardhat, foot protection, and hearing protection.** Protect your hearing if you are exposed to long periods of very noisy job-site operations.
7. **Watch for pinch points.** Do not put fingers under the valve body where they could be pinched by the weight of the valve. Use caution around spring-loaded components, such as the clapper, the clapper latch, and the piston assembly.
8. **Keep work areas clean.** Cluttered areas, benches, and slippery floors can create hazardous working conditions.
9. **Keep visitors away.** Keep all visitors a safe distance away from work areas.

MAINTENANCE AND TESTING

1. **Notify the authority having jurisdiction.** Always notify the authority having jurisdiction before taking a fire protection system out of service, or before performing any maintenance that eliminates the fire protection provided by the system.
2. **Depressurize and drain the system completely before performing any maintenance.** Water under pressure, trapped air, or system air pressure may be present and can create hazardous conditions.
3. **Follow NFPA requirements for testing and inspection schedules.** Contact the local authority having jurisdiction for any additional requirements.
4. **Keep the dry system away from corrosive atmospheres and foreign matter.** Any condition that might degrade the system or affect system performance must be avoided.

INTRODUCTION

The following instructions are a guide for proper installation of Victaulic Series 756 Dry Valves. These instructions involve pipe that is properly prepared and grooved in accordance with current Victaulic specifications.

TRIM DIMENSIONS

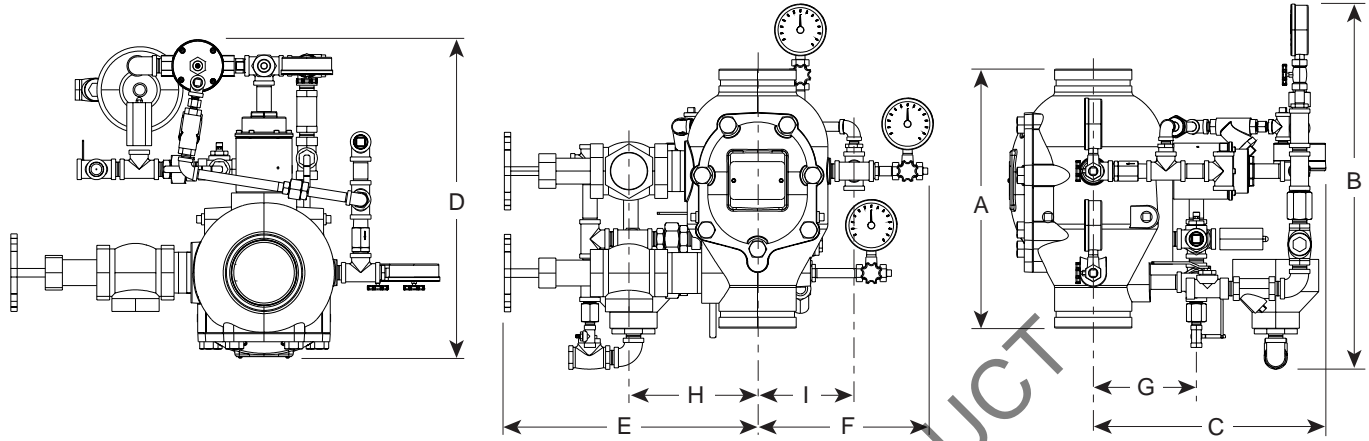

10.35-1B

VALVE SIZE Nominal Inches Actual mm	Dimensions Inches/mm									Aprx. Weight Each Lbs./kg			
	A	B	C	D	E	F	G	H	I	Without Trim		With Trim	
										Flanged	Grooved	Flanged	Grooved
GROOVED X GROOVED													
1½ 48,3	9.00 228,6	21.00 533,4	13.00 330,2	18.00 457,0	13.00 330,2	10.00 254,0	7.00 177,8	4.00 101,6	4.00 101,6	-	16.7 7,6	-	43.0 19,5
2 60,3	9.00 228,6	21.00 533,4	13.00 330,2	18.00 457,0	13.00 330,2	10.00 254,0	7.00 177,8	4.00 101,6	4.00 101,6	-	17.0 7,7	-	43.0 19,5
2½ 73,0	12.50 317,5	21.00 533,4	14.00 355,6	20.00 508,0	15.50 393,7	11.50 292,1	7.50 190,5	5.00 127,0	5.00 127,0	-	41.2 18,7	-	65.0 29,5
76,1 mm	12.50 317,5	21.00 533,4	14.00 355,6	20.00 508,0	15.50 393,7	11.50 292,1	7.50 190,5	5.00 127,0	5.00 127,0	-	41.2 18,7	-	65.0 29,5
3 88,9	12.50 317,5	21.00 533,4	14.00 355,6	20.00 508,0	15.50 393,7	11.50 292,1	7.50 190,5	5.00 127,0	5.00 127,0	-	42.1 19,1	-	65.0 29,5
4 114,3	15.00 381,0	20.00 508,0	15.00 381,0	21.00 533,4	14.00 355,6	12.00 304,8	8.00 203,2	9.00 228,6	6.00 152,4	-	55.0 24,9	-	95.0 43,1
6 168,3	16.00 406,4	21.10 535,9	16.00 406,4	22.00 558,8	14.00 355,6	12.00 304,8	8.50 215,9	7.00 177,8	7.00 177,8	-	73.0 33,1	-	115.0 52,2
165,1 mm	16.00 406,4	21.10 535,9	16.00 406,4	22.00 558,8	14.00 355,6	12.00 304,8	8.50 215,9	7.00 177,8	7.00 177,8	-	73.0 33,1	-	115.0 52,2
8 219,1	18.00 457,0	17.50 444,5	16.00 406,4	23.00 584,0	16.00 406,4	12.00 304,8	14.00 355,6	9.50 241,3	7.00 177,8	-	142.0 64,4	-	182.0 82,6
GROOVED X FLANGED													
4 114,3	16.00 406,4	20.00 508,0	15.00 355,6	21.00 533,4	14.00 355,6	12.00 304,8	8.00 203,2	9.00 228,6	6.00 152,4	65.0 29,5	-	105.0 47,6	-
6 168,3	17.00 431,8	21.10 535,9	16.00 406,4	22.00 558,8	14.00 355,6	12.00 304,8	8.50 215,9	7.00 177,8	7.00 177,8	83.0 37,6	-	125.0 56,7	-
165,1 mm	17.00 431,8	21.10 535,9	16.00 406,4	22.00 558,8	14.00 355,6	12.00 304,8	8.50 215,9	7.00 177,8	7.00 177,8	83.0 37,6	-	125.0 56,7	-
8 219,1	19.30 490,2	18.00 457,0	16.00 406,4	23.00 584,0	16.00 406,4	12.00 304,8	14.00 355,6	9.50 241,3	7.00 177,8	155.0 70,3	-	195.0 88,5	-

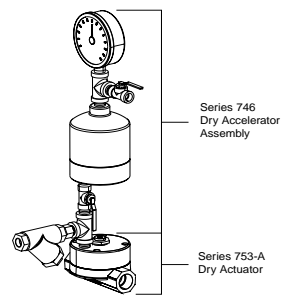

NOTE: An optional Series 746 Dry Accelerator assembly adds approximately 13.5" (342.9 mm) onto the top of the Series 753-A Dry Actuator.

EXPLODED VIEW DRAWING – TRIM COMPONENTS

Series 756 Dry System Valve
 (Pressure Switch, Accelerator, and Air Maintenance Trim OPTIONAL)
 Grooved X Grooved

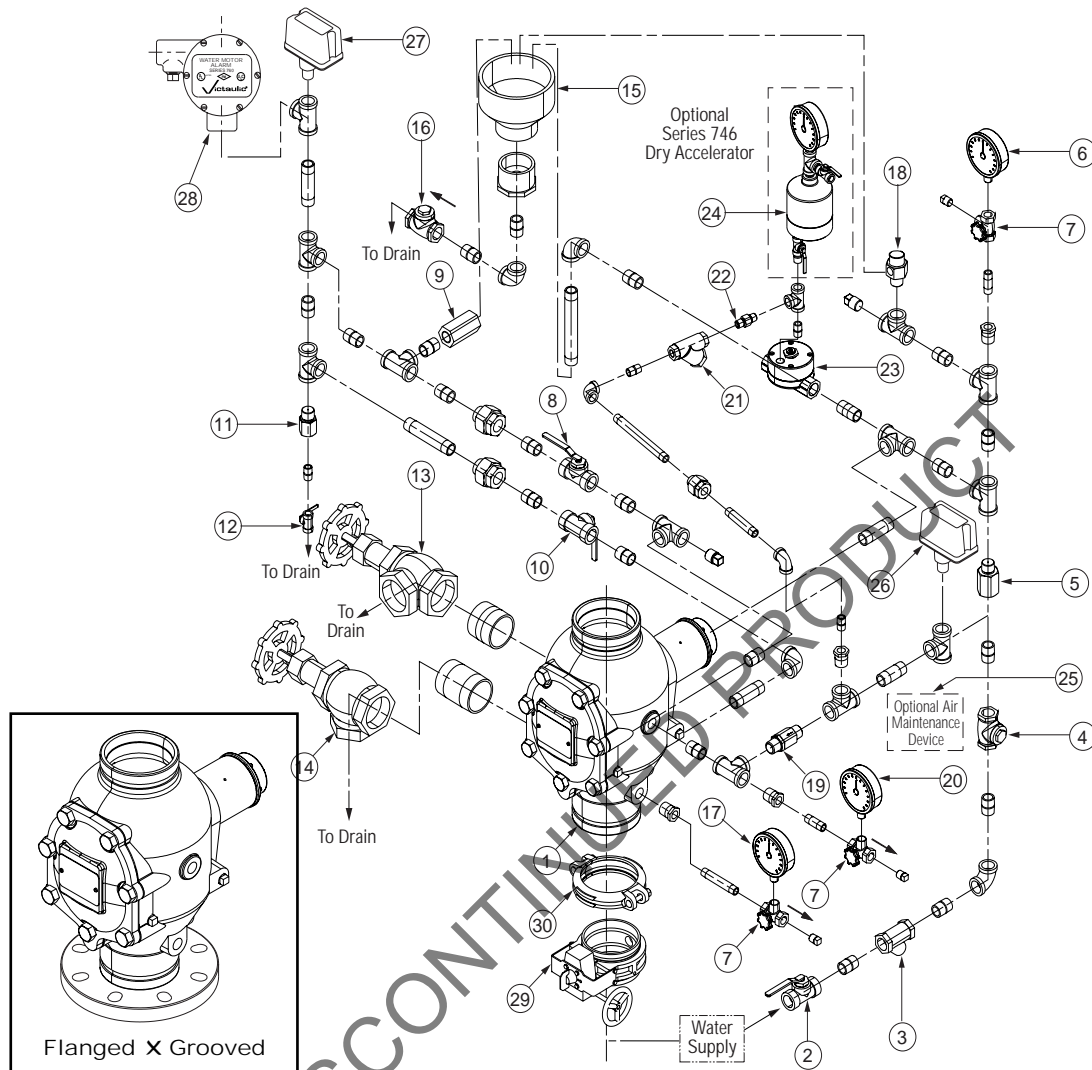

BILL OF MATERIALS

- | | |
|---|--|
| 1 Series 756 FireLock Dry System Valve | 16 Drain Check Valve |
| 2 Piston Charge Line Ball Valve (NO) | 17 Water Supply Pressure Gauge (0-300 psi) |
| 3 Piston Charge Line Strainer (100 Mesh) | 18 Series 749 AutoDrain |
| 4 Piston Charge Line Check Valve | 19 Series 748 Ball Check |
| 5 Piston Charge Line Restrictor (.070") | 20 System Pressure Gauge (0-80 psi with retard) |
| 6 Piston Charge Line Pressure Gauge (0-300 psi) | 21 Air Line Strainer (100 Mesh) |
| 7 Gauge Valve | 22 Air Line Restrictor (1/16") |
| 8 Alarm Line Ball Valve (NO) | 23 Series 753A Dry Actuator |
| 9 Series 729 Drip Check Valve | 24 Series 746 Dry Accelerator (Optional) |
| 10 Alarm Test Line Ball Valve (NC) | 25 Series 757 Air Maintenance Device (Optional) |
| 11 Alarm Line Drain Restrictor (1/16") | 26 EPS-40 Low Air Pressure Switch (Optional) |
| 12 Alarm Line Drain Ball Valve (NC) | 27 EPS-10 Alarm Pressure Switch (Optional) |
| 13 Main System Drain Valve | 28 Series 760 Water Motor Alarm (Optional) |
| 14 Main Drain Valve - Flow Test | 29 Series 705W Butterfly Valve (Optional) with Tap |
| 15 Drip Cup | 30 Style 005 FireLock Rigid Coupling (Optional) |

NO = Normally Open; NC = Normally Closed

EXPLODED VIEW DRAWING - INTERNAL VALVE COMPONENTS

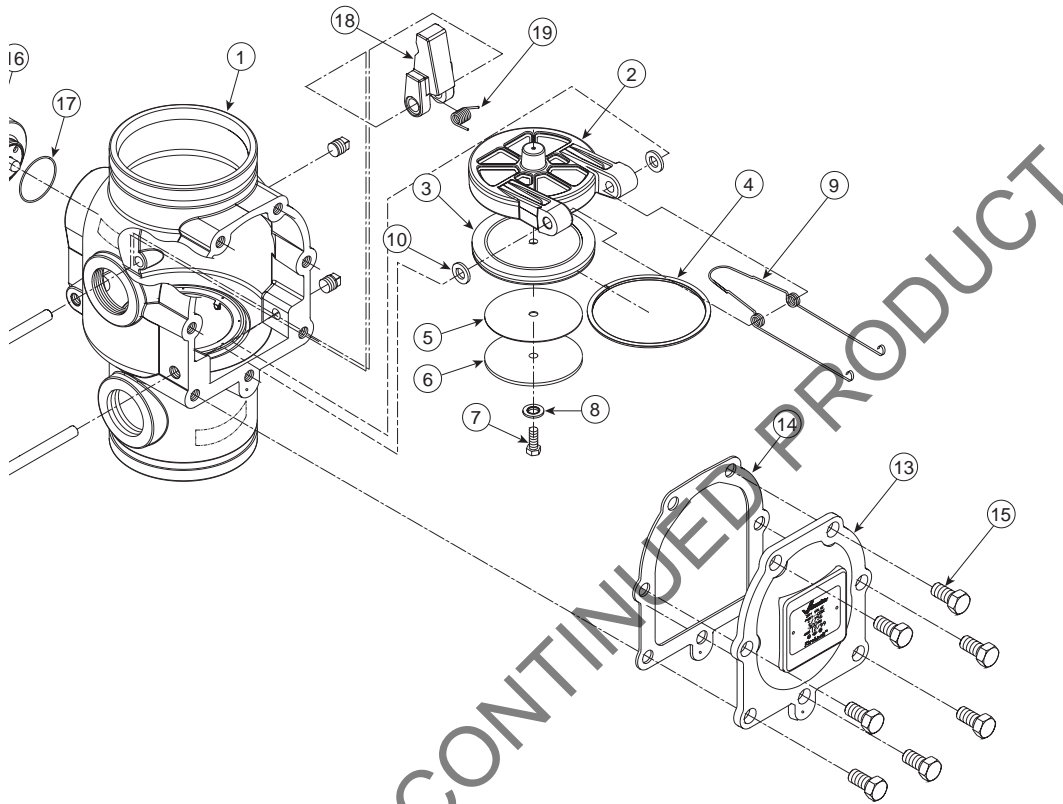

BILL OF MATERIALS

Body

8 Bolt Seal

15 Cover Plate Bolts (Qty 7)

SERIES 756 DRY VALVE WITH SERIES 753-A DRY ACTUATOR - TRIM ASSEMBLY DRAWING NUMBERS

Valve Size inches (mm)	Vertical Trim Drawing Number	Horizontal Trim Drawing Number	Valve Size inches (mm)	Vertical Trim Drawing Number	Horizontal Trim Drawing Number
1½ 48,3	Z014756401	Z014756451	4 114,3	Z040756401	Z040756451
2 60,3	Z014756401	Z014756451	6 168,3	Z060756401	Z060756451
2½ 73,0	Z024756401	Z024756451	165,1 mm 8 219,1	Z060756401	Z060756451
76,1 mm	Z024756401	Z024756451		Z080756401	Z080756451
3 88,9	Z024756401	Z024756451			

SECTION VIEW DRAWING AND DESCRIPTION – SERIES 753-A DRY ACTUATOR

The Victaulic Series 753-A Dry Actuator is a pneumatically actuated valve used to trigger the operation of Series 756 Dry Valve systems.

System air pressure in the upper chamber sets the dry actuator in the closed position; this holds the clappers shut, since water cannot escape from the piston.

When a sprinkler head opens and system air pressure is released, air evacuates from the upper chamber. The lower chamber then opens and permits water to escape from the piston, resulting in valve operation.

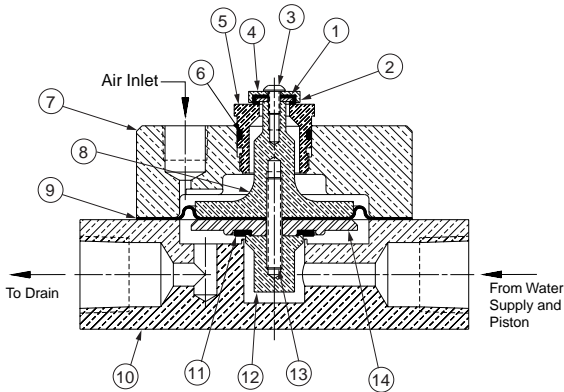

BILL OF MATERIALS			
Item	Description	Item	Description
1	Upper Chamber Seal	8	Actuator Shaft
2	Washer	9	Diaphragm
3	Button Head Cap Screw	10	Lower Chamber
4	Seal Support	11	Seal
5	Adjustable Seat	12	Seal Retainer
6	O-ring	13	Threaded Rod
7	Upper Chamber	14	Piston

SECTION VIEW DRAWING AND DESCRIPTION – SERIES 746 DRY ACCELERATOR

The Series 746 Dry Accelerator acts as an exhaust for the Series 753-A Dry Actuator.

A diaphragm separates the Series 746 Dry Accelerator into two chambers. The lower chamber contains a compression spring, which maintains the lower chamber in the closed position. This closed position is maintained as long as the pressure differential between the upper and lower chambers is less than 3 psi (21 kPa).

When the system introduces air pressure into the dry accelerator, the air goes into the lower chamber and passes through a built-in check valve to the upper air chamber. The built-in check valve, which allows flow into the upper chamber, prevents pressure from escaping the upper air chamber. Therefore, air can escape only through the restrictor.

When a rapid loss of system air pressure occurs, such as an open sprinkler head, air escapes from the lower chamber faster than it does from the upper air chamber. As the sprinkler system's pressure continues to decay, a differential pressure develops across the diaphragm. When this differential pressure reaches 3 – 5 psi (21 – 34 kPa), the upper chamber's pressure overcomes the compression spring's closing force, causing the lower chamber to open to the atmosphere. The lower air chamber opens immediately and releases pressure from the Series 753-A Dry Actuator, resulting in valve operation.

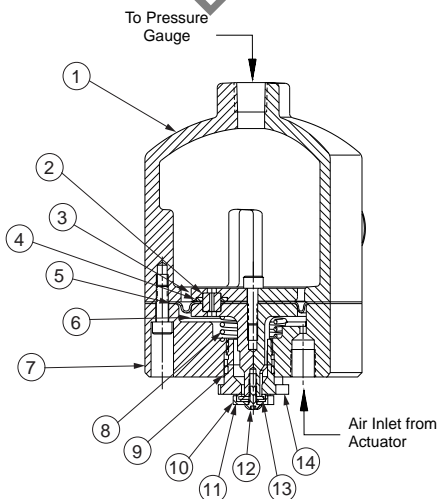

BILL OF MATERIALS			
Item	Description	Item	Description
1	Air Chamber	8	Compression Spring
2	Restrictor	9	O-ring
3	Piston	10	Seal Support
4	O-ring	11	Upper Chamber Seal
5	Diaphragm	12	Button Head Cap Screw
6	Actuator Shaft	13	Washer
7	Upper Chamber	14	Adjustable Seat

RECOMMENDED AIR PRESSURES FOR SERIES 756 DRY VALVES WITH SERIES 753-A DRY ACTUATORS AND/OR SERIES 746 DRY ACCELERATORS

RECOMMENDED AIR PRESSURE FOR DRY AND PNEUMATIC ACTUATED SYSTEMS

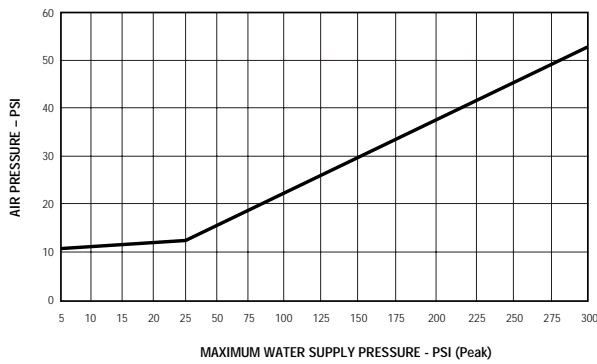

COMPRESSOR REQUIREMENTS

COMPRESSOR REQUIREMENTS

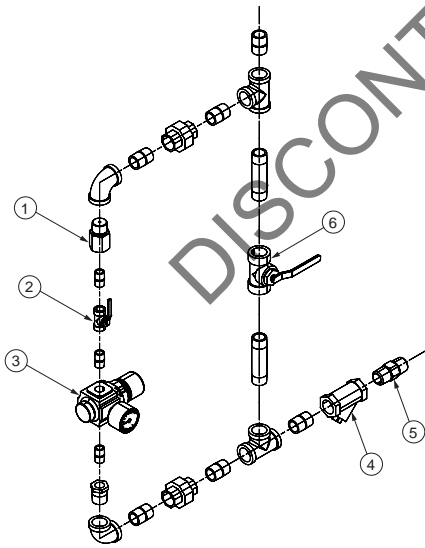
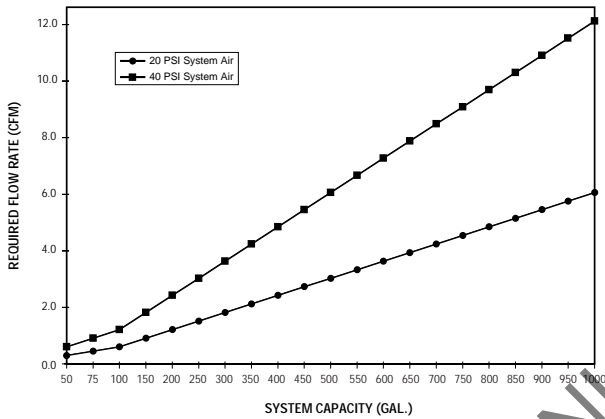

BILL OF MATERIALS

Item	Description
1	1/16 -inch Restrictor
2	Slow Fill Ball Valve
3	Air Regulator
4	Strainer (100 Mesh)
5	Spring-Loaded, Soft-Seated Check Valve
6	Fast Fill Ball Valve

NOTES:

- 1) The Victaulic air regulator is a relief-type design. Any pressure in the system that is above the set point of the regulator will be released. Therefore, charging the regulator above the set point could cause premature operation of a valve installed with a Series 746 Dry Accelerator.
- 2) The recommended air pressures, shown in the chart to the left, apply to dry valves that use a Series 753-A Dry Actuator.
- 3) For base or riser-mounted compressors, the recommended air pressures are the "on" or "low" pressure settings for the compressor.
- 4) For tank-mounted compressors, the recommended air pressures are the set point for the air regulator. The "on" pressure of the compressor should be at least 5 psi (34 kPa) above the set point of the regulator.
- 5) These pressures involve an 8-to-1 water-to-air ratio, plus a 10-pound safety factor.

EXAMPLE: For a system with an underground pressure of 80 psi (552 kPa):

Per the chart, the pressure should be set at 20. In addition, this pressure could be calculated by dividing the system's maximum water pressure by 8 and then adding 10 psi (69 kPa).

COMPRESSOR AND AIR MAINTENANCE TRIM REQUIREMENTS

NOTICE

- In the event that a compressor becomes inoperative, a properly sized tank-mounted air compressor provides the greatest protection for systems that use a Series 746 Dry Accelerator. In this situation, air can be supplied continuously to the sprinkler system for an extended time period.
- If multiple dry valves are installed with a common air supply, isolate the systems by using a spring-loaded, soft seat-check valve to ensure air integrity for each system.

Air Supply Design

! WARNING



• Air supply systems must be properly sized. Failure to follow this instruction could cause improper valve operation, resulting in serious personal injury and/or property damage.

1. The engineer/system designer is responsible for sizing the compressor so that it brings the entire system to the required pressure within 30 minutes. DO NOT oversize the compressor to provide more airflow, since it will slow down or possibly prevent valve operation.
2. Continuous service (24 hours per day, 7 days per week) is required to prevent the valve from false tripping due to a loss of air pressure.
3. Regulate the air pressure to the proper system air pressure. Air pressure differing from the required system air pressure could adversely affect system operation.
4. Restrict the air supply to ensure that air being exhausted from an open head or manual release valve is not replaced by the air supply system as fast as it is being exhausted.
5. Recommended practice is to provide an inspector's test connection on the release system.

5a. The inspector's test connection should contain a globe valve (normally locked closed), which can be opened to simulate actuation.

5b. Locate the inspector's test connection at the highest, most hydraulically demanding location in the release system. **NOTE:** Multiple restrictions on the inspector's test may slow the air decay rate, causing the system to respond slower than required.

5c. The inspector's test connections should terminate with an orifice equal to the smallest orifice in the releasing system.

5d. The inspector's test connection is used to ensure that water gets to the most remote part of the system within 60 seconds.

6. When shop air or a tank-mounted air compressor is installed, the air maintenance trim assembly **MUST** be used. The air maintenance trim assembly provides proper air regulation to the sprinkler system.

Proper Air Supplies for Series 756 Dry Valves Used with Series 753-A Dry Actuators Only:

1. When a riser or base-mounted air compressor supplies air to a system using a Series 753-A Dry Actuator, it is not necessary to use the air maintenance trim assembly with an air regulator. In this case, the airline of the compressor connects to the trim at the fitting where the air maintenance trim is normally installed.

2. Due to the large on/off differential available for pressure switches that control base-mounted compressors, adjust the compressor's pressure switch so that the "ON" contact is at the recommended air supply for the valve.

Proper Air Supplies for Series 756 Dry Valves Used with Series 753-A Dry Actuators and Series 746 Dry Accelerators:

1. When a Series 746 Dry Accelerator is used with the Series 753-A Dry Actuator, the air maintenance trim assembly **MUST** be used with the air regulator.

2. In the event that a compressor becomes inoperative, a properly sized tank-mounted air compressor provides the greatest protection for systems that use a Series 746 Dry Accelerator. In this situation, air can be supplied continuously to the sprinkler system for an extended time period.

IMPORTANT INSTALLATION INFORMATION

1. For proper operation and approval, the Series 756 Dry Valve must be installed in accordance with the specific trim diagrams. **NOTE:** Victaulic provides specific trim drawings for installations that involve a Series 746 Dry Accelerator.

2. Before installing the Series 756 Dry Valve, flush the water supply piping thoroughly to ensure that no foreign material is present.

3. The Series 756 Dry Valve **MUST NOT** be located in an area where the valve is subject to freezing temperatures or physical damage.

4. It is the owner's responsibility to confirm material compatibility of the Series 756 Dry Valve, trim, and associated accessories when a corrosive environment or contaminated water is present.

5. Series 756 Dry Valves can be installed in the vertical position with the arrow on the body pointing upward or horizontally with the cover plate facing upward.

6. Air or nitrogen supply to the dry piping system must be clean, dry, and oil-free.

7. Automatic air supplies must be regulated, restricted, and continuous. **NOTE:** Victaulic recommends the use of an air maintenance device on any system with an automatic air supply.

8. When the Series 756 Dry Valve is used with a water motor alarm, the valve must contain an uninterrupted, low-pressure alarm that is installed in the piston.

VALVE/TRIM INSTALLATION

1. Make sure trim drawings match system requirements.

! WARNING	
	<ul style="list-style-type: none">• Make sure the foam spacer is removed before attempting to install the valve. <p>Failure to follow this instruction could cause improper valve operation, resulting in serious personal injury and/or property damage.</p>

2. Remove all plastic caps and foam spacers from valve.

3. Apply a small amount of pipe joint compound or Teflon* tape to external threads of all threaded pipe connections. Be careful not to get any tape, compound, or other foreign material into valve body, pipe nipples, or valve openings.

4. For valves 3" (88,9 mm) or smaller:

4a. Remove piston assembly before trimming valve.

4b. Unscrew piston from valve body, and note position of o-ring. This o-ring must be installed in the same position when the piston is reassembled.

4c. Install trim to back of valve, per applicable trim drawings.

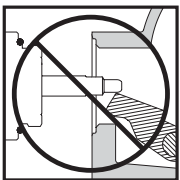
! WARNING	
	<ul style="list-style-type: none">• Make sure piston is reassembled and reinstalled correctly. <p>Failure to do so could cause improper valve operation, resulting in serious personal injury and/or property damage.</p>

4d. Reassemble piston, making sure o-ring is positioned properly and that the piston rod and latch engage properly. **NOTE:** It may be necessary to rotate latch inward (toward center of valve body) to ensure proper alignment.

4e. Tighten piston until metal-to-metal contact occurs between piston and valve body.

5. Install valve, trim, and accessories per applicable trim drawings.

6. For valves installed with a Series 746 Dry Accelerator:

6a. Make sure the Series 746 Dry Accelerator is installed on the Series 753-A Dry Actuator, as shown in the drawing below. The end with the vent seal "button" must be installed toward the dry actuator.

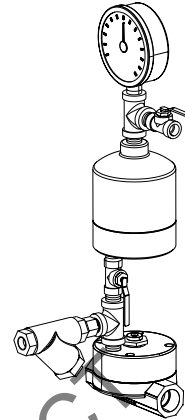

7. Provide an uninterrupted source of water from upstream of the main control valve to supply pressure to the piston charge line.

IMPORTANT SETTINGS

1. Wire the air supervisory switch to activate a low-pressure alarm signal. **NOTE:** The authority having jurisdiction may also require a high-pressure alarm.

2. Set the air supervisory switch to activate at 5-psi (34-kPa) below the minimum air pressure required.

3. Wire the alarm pressure switch to activate a water flow alarm.

4. Set the alarm pressure switch to activate on a pressure rise of 4 – 8 psi (25 – 55 kPa).

HYDROSTATIC TESTING

! WARNING	
	<ul style="list-style-type: none">• If air testing is required, DO NOT exceed 50 psi (345 kPa) air pressure. <p>Failure to follow this instruction could result in serious personal injury, property damage, and/or product damage.</p>

The Victaulic Series 756 Dry Valve is manufactured and listed for a maximum working pressure of 300 psi (2065 kPa) and is factory tested to 600 psi (4135 kPa). The valve may be hydrostatically tested to 200 psi (1380 kPa) and/or 50 psi (345 kPa) above the normal water supply pressure (2-hour limited time period) for acceptance by the authority having jurisdiction.

*Teflon is a registered trademark of I. E. Dupont de Nemours

PLACING THE SYSTEM IN SERVICE

⚠ WARNING

- Make sure the Series 756 Dry Valve is properly heated and protected from freezing temperatures and physical damage.
- Failure to follow this instruction could cause improper valve operation, resulting in serious personal injury and/or property damage.

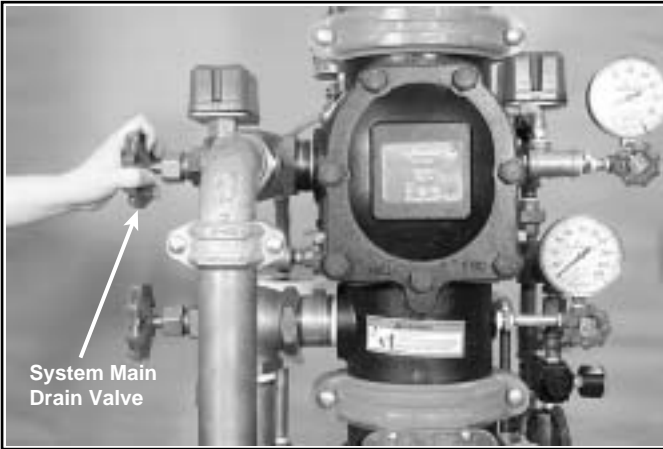

1. Open system main drain valve, as shown above. Confirm that the system is drained.

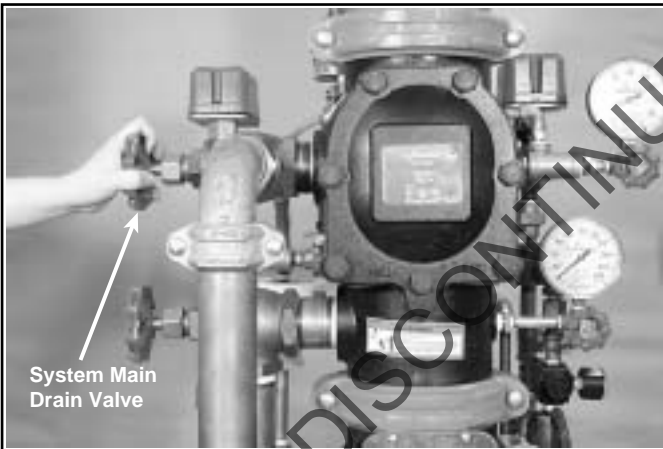

2. Close system main drain valve.

3. Confirm that system drains are shut and the system is free of leaks.

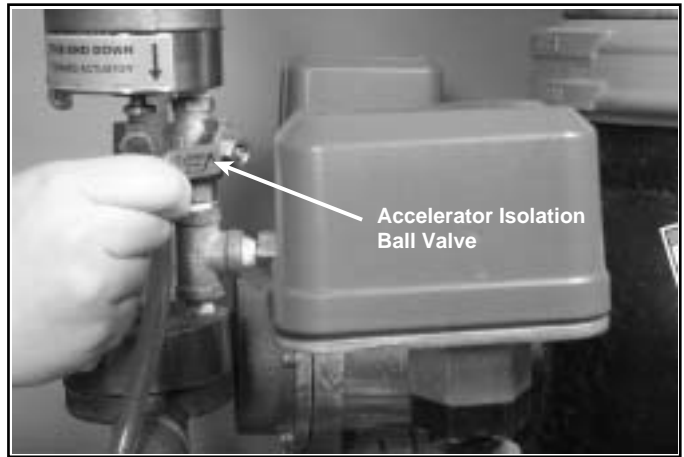

4. If a Series 746 Dry Accelerator is used, confirm that the isolation ball valve to the accelerator is closed.

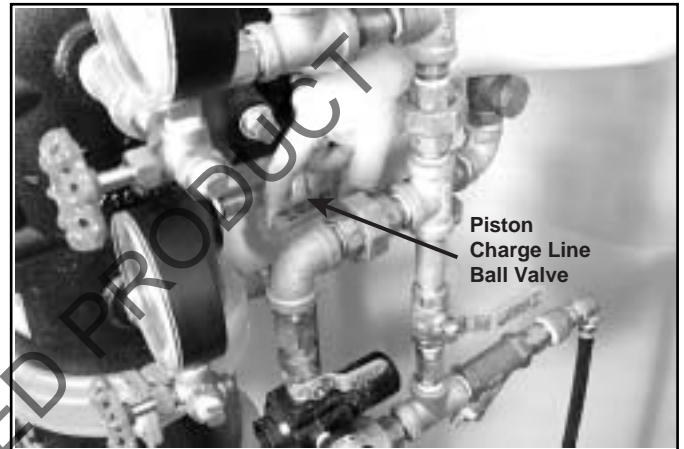

5. Open piston charge line ball valve, and allow a steady flow of water to go through actuator.

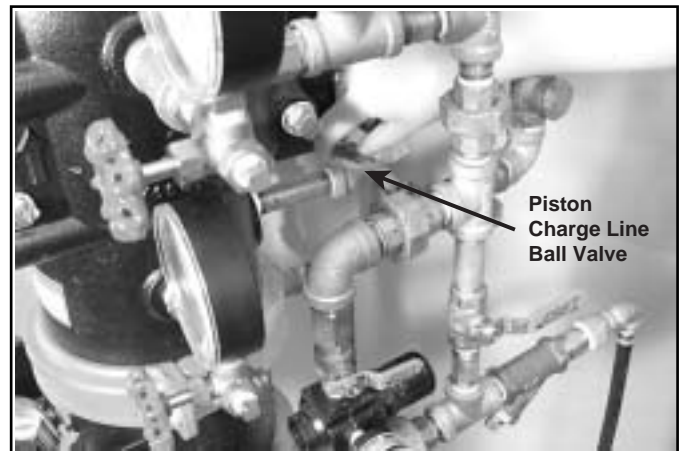

6. Close piston charge line ball valve.

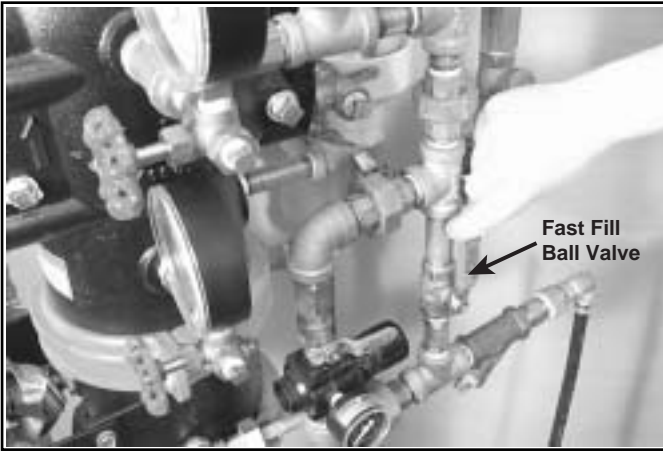

7. Open fast fill ball valve on air maintenance device. Fill the system to the appropriate air pressure for the typical water supply pressure in the area.

7a. Confirm that the system is charging by observing the air pressure gauge. If the gauge is not showing an increase in air pressure, there is a leak or an open line in the system.

7b. If air is leaking out of drip check on alarm line, close alarm line ball valve (shown above step 4 on page 16).



8. While system is charging, it may be necessary to push down on upper chamber seal of Series 753-A Dry Actuator.

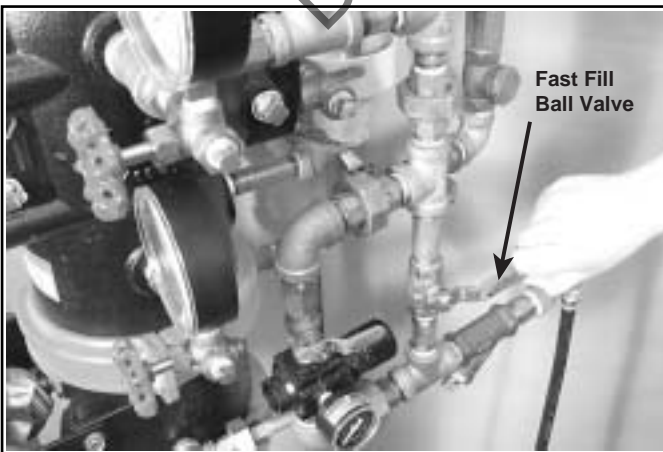

9. Once system air pressure is established, close fast fill ball valve.

NOTICE

- The Victaulic air regulator is a relief-type design.
- Any pressure in the system that is above the set point will be released. Therefore, charging the regulator above the set point could cause premature operation of a valve installed with a Series 746 Dry Accelerator.

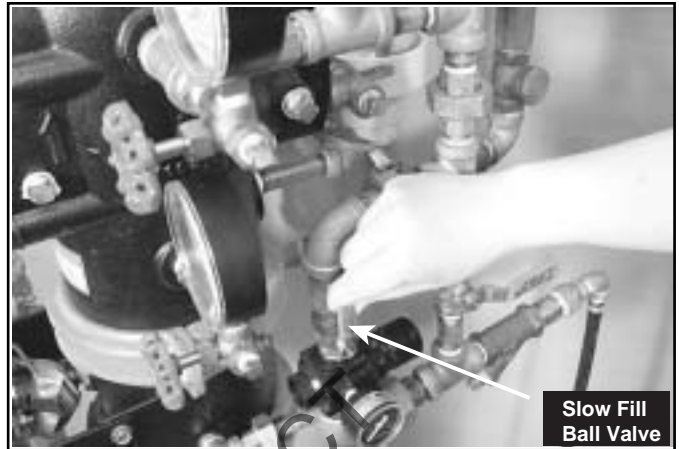

10. Open slow fill ball valve. Confirm air regulator is set to the proper system pressure.

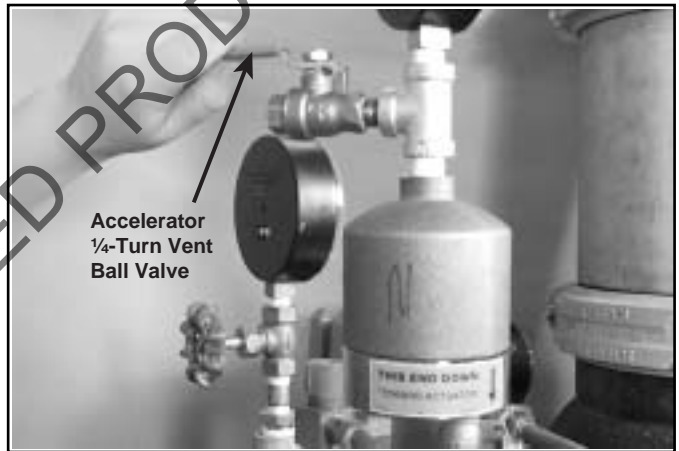

11. If a Series 746 Dry Accelerator is used, open the 1/4-turn vent ball valve on the accelerator, as shown above.

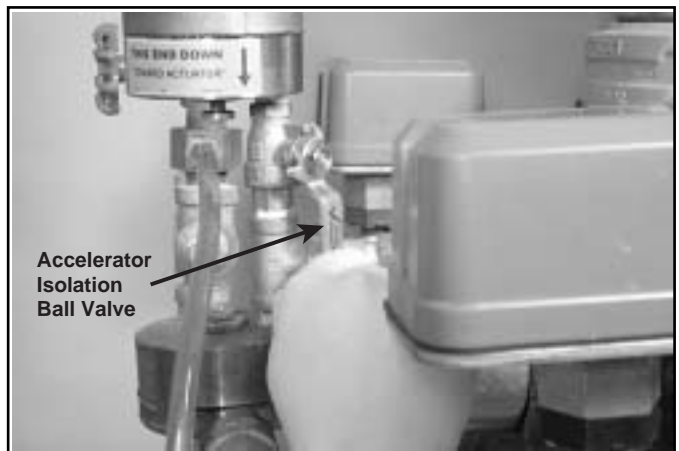

11a. Open isolation ball valve on Series 746 Dry Accelerator.



11b. Close 1/4-turn vent ball valve on Series 746 Dry Accelerator. This will set the accelerator.

12. Observe system air pressure over a 24-hour period to confirm system integrity. If there is degradation in system air pressure, find leaks and correct. **NOTE:** NFPA requires less than 2-psi (14-kPa) leakage in 24 hours.

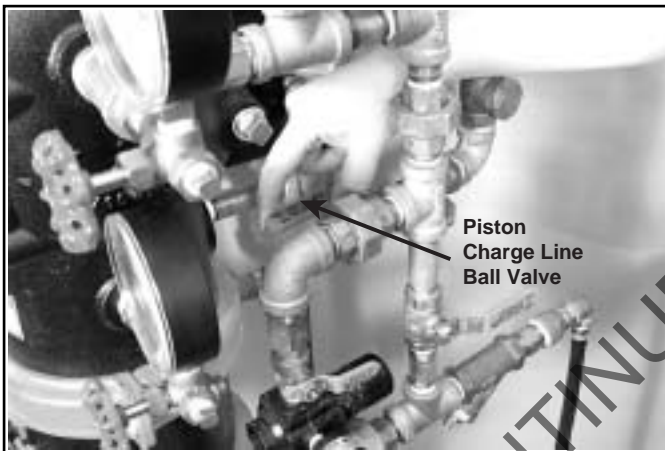

13. Open piston charge line ball valve.



14. Remove protective cap from Series 749 Auto Drain.



15. Pull up on auto drain set screw until auto drain is set (approximately 10 psi/69 kPa). Replace protective cap on auto drain.

⚠ CAUTION

- Make sure the protective cap is replaced on the auto drain set screw to avoid accidental contact. Hitting the set screw will cause the valve to trip, resulting in property damage.

SERIES 749 AUTO DRAIN ASSEMBLY

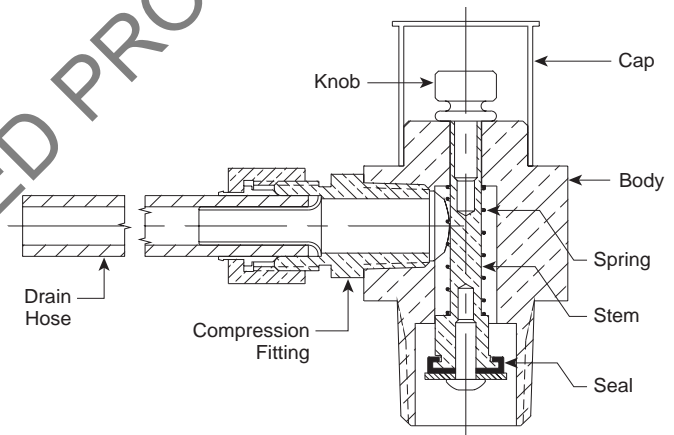

16. Allow system to pressurize. Confirm that water pressure is established. The piston is now actuated, and the clapper will now be set.

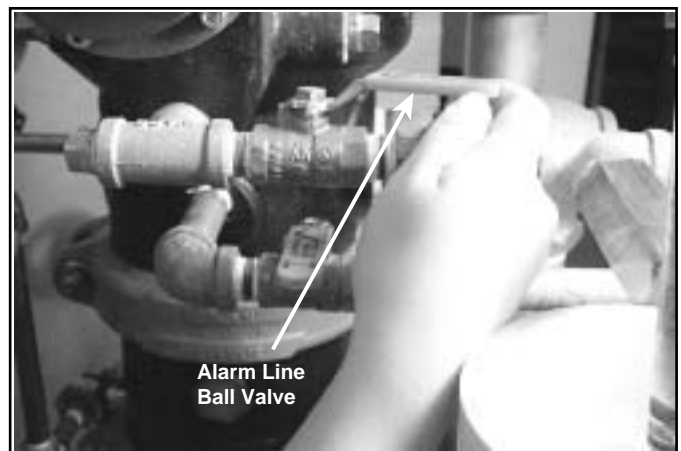

17. Open alarm line ball valve.

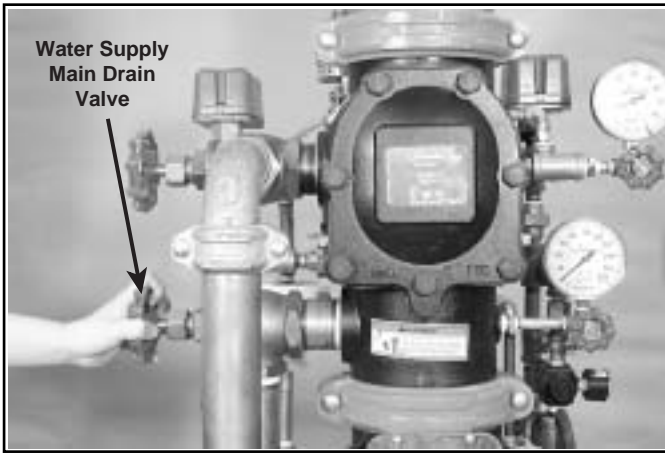

18. Open watersupply main drain valve, as shown above.

⚠ CAUTION

- Take precautions when opening the water supply main control valve, since water will flow from all open system valves. Failure to do so could result in personal injury and property damage.



19. Open watersupply's main control valve slowly until a steady flow of water flows from the open water supply main drain valve.

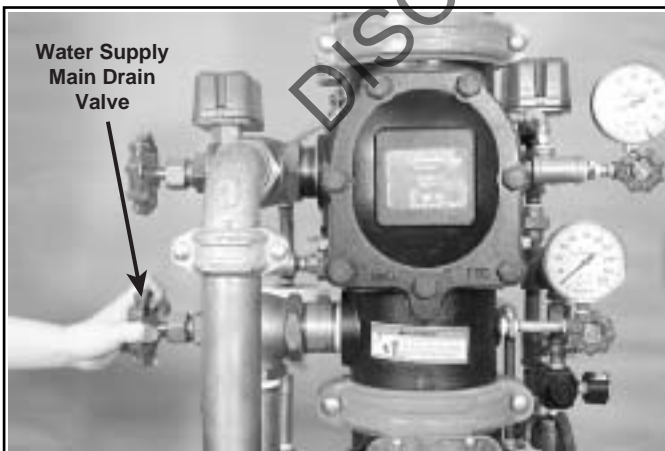

20. When a steady flow of water occurs, close water supply main drain valve.

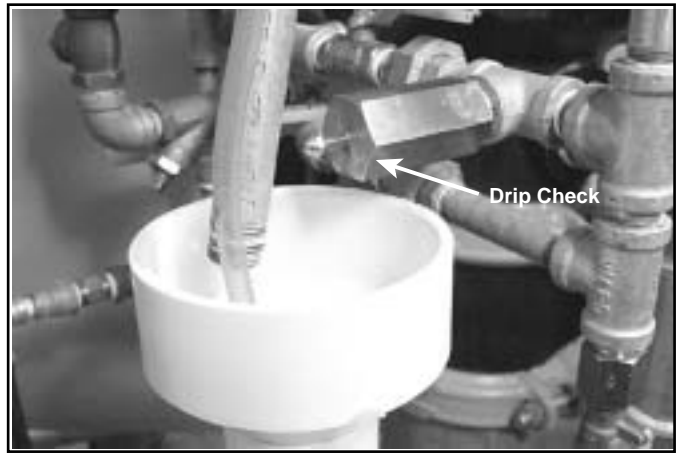

20a. Confirm that there is no leakage from the drip check located in the alarm line's piping. If water is flowing from the drip check, close the water supply's main control valve, and start over at step 1.



21. Open water supply's main control valve fully.

22. Record system air pressure and water supply pressure.

23. Secure all valves in their normal operating positions (refer to table below).

Valve	Normal Operating Position
Piston Charge Line Ball Valve	Open
Alarm Line Ball Valve	Open
Alarm Test Ball Valve	Closed
Alarm Drain Ball Valve	Closed

24. Notify the authority having jurisdiction, remote station alarm monitors, and those in the affected area that the system is in service.

EXTERNAL INSPECTION

WARNING



- Any activities that require taking the valve out of service may eliminate the fire protection provided.
 - Before servicing or testing the system, notify the authority having jurisdiction.
 - Consideration of a fire patrol should be given in the affected areas.
- Failure to follow these instructions could result in serious personal injury and/or property damage.

NOTICE

- The owner is responsible for maintaining the fire protection system in proper operating condition.
- It is important that the system is inspected regularly, according to proper procedures.
- The Victaulic Series 756 Dry Valve and trim must not be exposed to foreign material, corrosive environments, freezing conditions, contaminated water supplies, or any other condition that could impair proper system operation.
- Modify the frequency of inspections in the presence of any environmental conditions that could degrade system operation.
- The National Fire Protection Association pamphlet, which describes the care and maintenance of sprinkler systems, outlines the minimum requirements for inspections and tests.
- The authority having jurisdiction may have additional maintenance, inspection, and test requirements.

Weekly Inspection

1. Perform a visual inspection on the valve and trim on a weekly basis. **NOTE:** If the dry system is equipped with a low-pressure alarm, monthly inspections may be sufficient. Consult with the local authority having jurisdiction for specific requirements.

Monthly Inspection

1. Record system air pressure and water supply pressure. Confirm that the water supply pressure is in the range of normal pressures observed in the area. Significant loss in water supply pressure could indicate an adverse condition in the water supply. Confirm the proper water-to-air ratio is being maintained.
2. Confirm that there is no leakage from the intermediate valve chamber. No water or air should flow from the drip check.
3. Check for mechanical damage or corrosion. If found, replace affected parts.
4. Confirm that the dry valve and trim are not subject to freezing temperatures.
5. Verify that all valves are in their normal operating positions (refer to table below).

Valve	Normal Operating Position
Piston Charge Line Ball Valve	Open
Alarm Line Ball Valve	Open
Alarm Test Ball Valve	Closed
Alarm Drain Ball Valve	Closed

6. If the system includes the Series 746 Dry Accelerator, record the pressure in the accelerator's upper chamber. This pressure should equal the system air pressure within the allowable tolerances of the gauges. If the upper chamber's air pressure is below the system air pressure, follow the troubleshooting procedure for the accelerator on page 31.

REQUIRED TESTS

WARNING



- Any activities that require taking the valve out of service may eliminate the fire protection provided.
 - Before servicing or testing the system, notify the authority having jurisdiction.
 - Consideration of a fire patrol should be given in the affected areas.
- Failure to follow these instructions could result in serious personal injury and/or property damage.

Main Drain Test

Perform the main drain test on a frequency required by the current NFPA-25 code. The authority having jurisdiction in your area may require that you perform these tests on a more frequent basis. Verify these requirements by contacting the authority having jurisdiction in the affected area.

1. Notify the authority having jurisdiction, remote station alarm monitors, and those in the affected area that the main drain test will be performed.
2. Confirm that sufficient drainage is in place for a full-flow drain test.
3. Record water supply pressure and system air pressure.
4. Verify that the valve's intermediate chamber is dry. No water should flow from the drip check.
5. Verify that the system is pressurized at the proper air pressure for the local water supply pressure.

CAUTION

- Be careful not to open the system main drain valve accidentally. Opening the system main drain valve will cause the valve to operate, resulting in property damage.

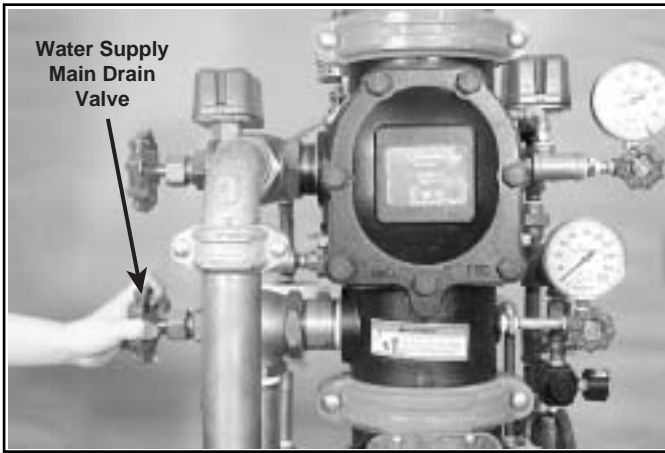

6. Open water supply main drain valve fully to flush water supply of any contaminants.

7. With the water supply main drain valve fully open, record the water supply pressure as the residual pressure.

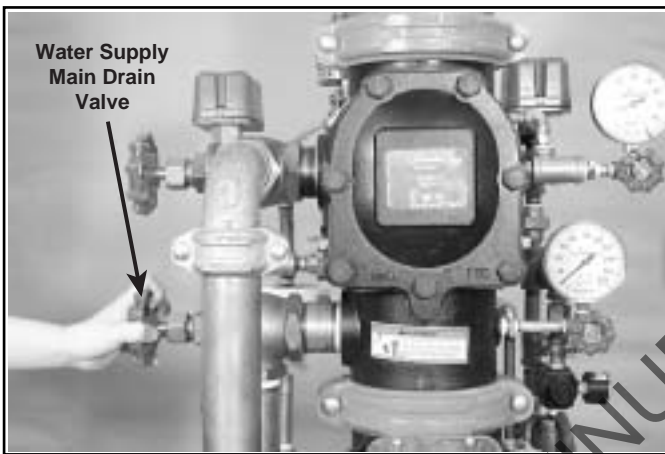

8. Close the water supply main drain valve slowly.

9. Record the water pressures established after closing the water supply main drain valve.

10. Compare the residual pressure reading, taken above, to the residual pressure readings taken in previous main drain tests. If there is degradation in the residual water supply readings, restore the proper water supply pressure.

11. Confirm that all alarm line valves are in their proper operating positions.

12. Confirm that there is no leakage from the valve's intermediate chamber. No water or air should flow from the drip check.

13. Notify the authority having jurisdiction, remote station alarm monitors, and those in the affected area that the valve is back in service.

14. Provide test results to the authority having jurisdiction, if required.

Water Flow Alarm Test

Perform the water flow alarm test on a frequency required by the current NFPA-25 code. The authority having jurisdiction in your area may require that you perform these tests on a more frequent basis. Verify these requirements by contacting the authority having jurisdiction in the affected area.

1. Notify the authority having jurisdiction, remote station alarm monitors, and those in the affected area that the water flow alarm test will be performed.

CAUTION

- Be careful not to open the system main drain valve accidentally. Opening the system main drain valve will cause the valve to operate, resulting in property damage.



2. Open water supply main drain valve fully to flush water supply of any contaminants.

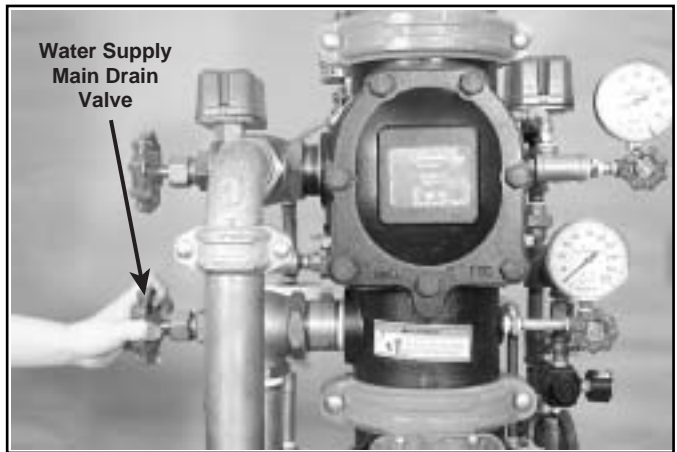

3. Close water supply main drain valve.

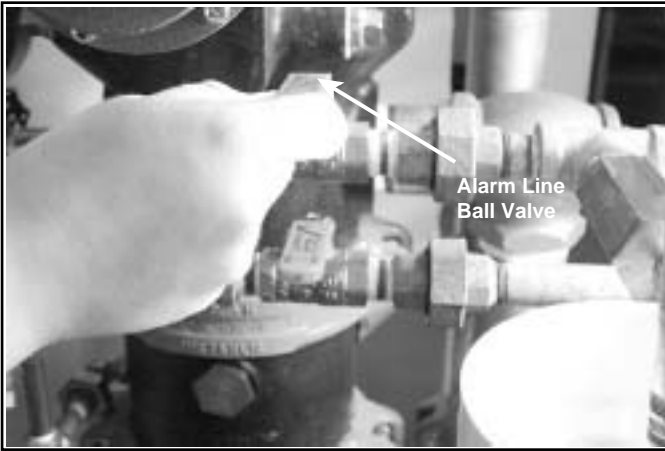

4. Close alarm line ball valve.

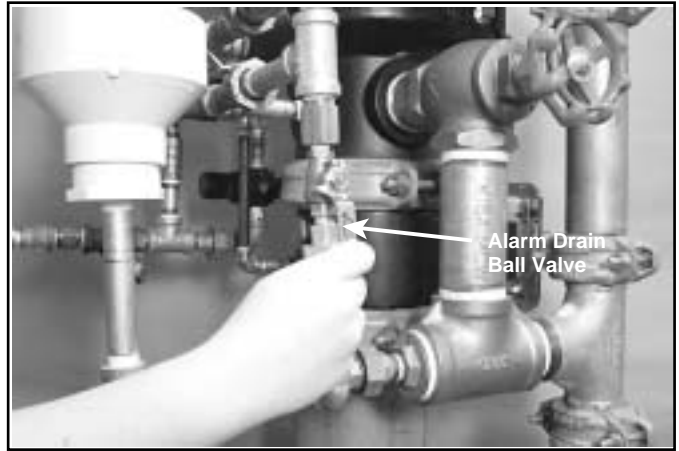

7. Open alarm drain ball valve, as shown above.

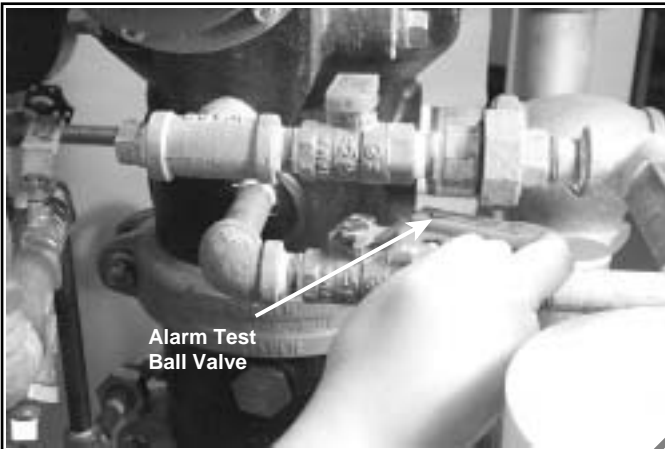

5. Open alarm test ball valve. Confirm that mechanical and electrical alarms provided are activated and that remote monitoring stations, if provided, receive an alarm signal.



9. Confirm that the alarm test ball valve is closed.



6. Close alarm test ball valve after proper operation of all alarms is verified.

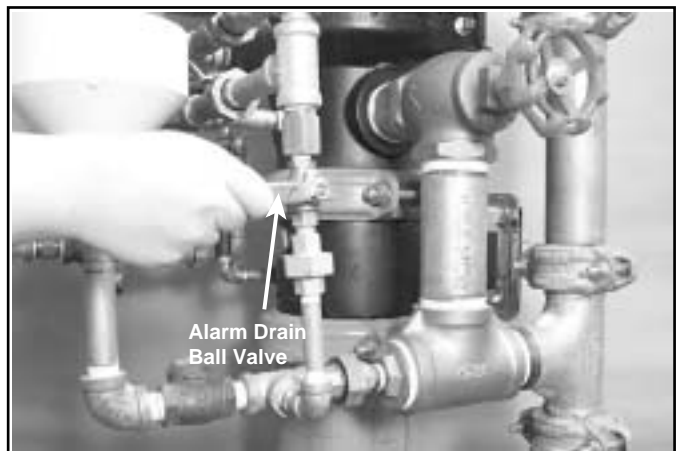

10. Close alarm drain ball valve.

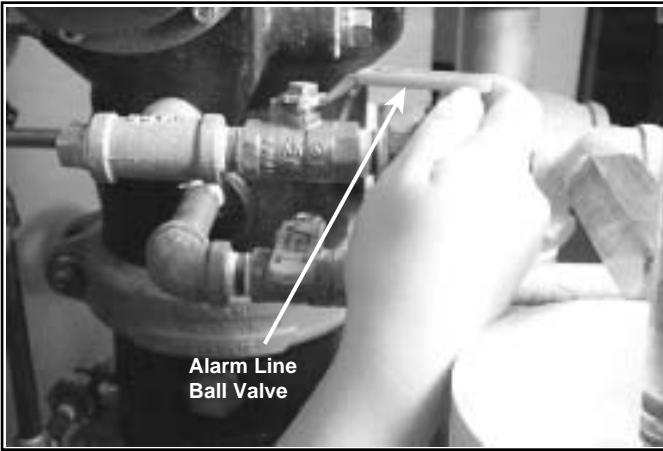

11. Open alarm line ball valve.

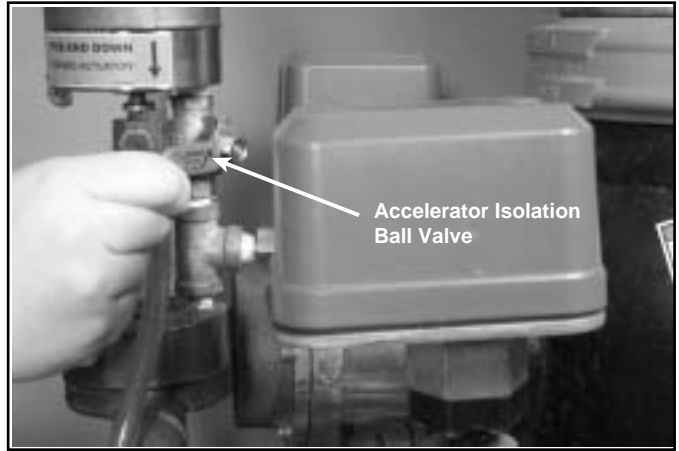

2. If the valve is equipped with a Series 746 Dry Accelerator, close the isolation ball valve.

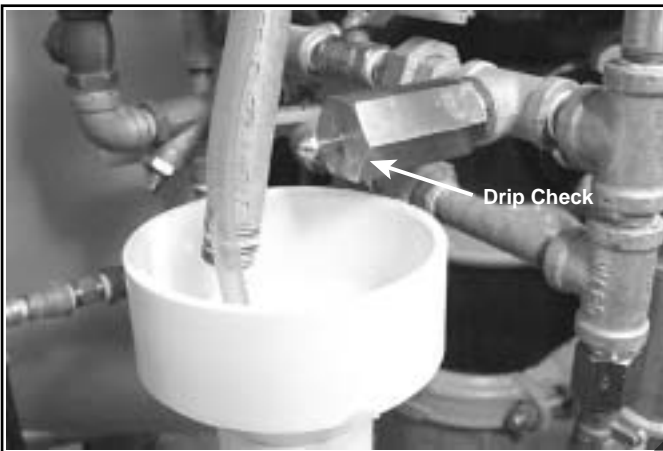

12. Verify that the valve's intermediate chamber is dry. No water should flow from the drip check.

13. Notify the authority having jurisdiction, remote station alarm monitors, and those in the affected area that the valve is back in service.

14. Provide test results to the authority having jurisdiction, if required.

Water Level and Low-Air Alarm Tests

Perform the water level and low-air alarm tests on a frequency required by the current NFPA-25 code. The authority having jurisdiction in your area may require that you perform these tests on a more frequent basis. Verify these requirements by contacting the authority having jurisdiction in the affected area.

NOTICE

- Be sure to notify the authority having jurisdiction that these tests are in progress. Failure to close the isolation ball valve of the Series 746 Dry Accelerator may cause the valve to trip, resulting in a false alarm.

1. Notify the authority having jurisdiction, remote station alarm monitors, and those in the affected area that the water level and low-air alarm tests will be performed.



3. Open water supply main drain valve fully to flush water supply of any contaminants.



4. Close water supply's main control valve.

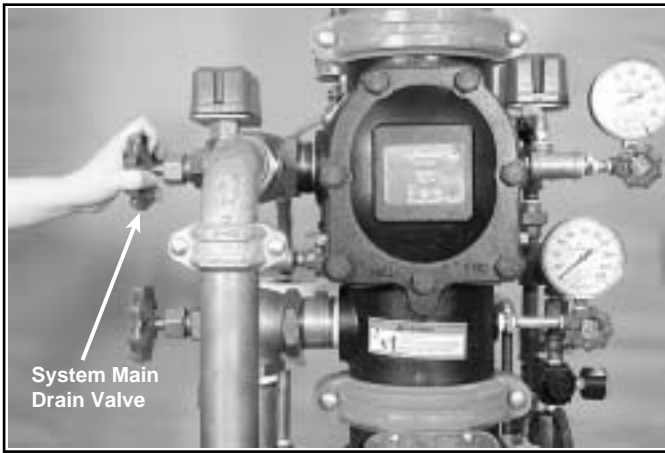

5. Partially open system main drain valves slowly. Confirm that no water is flowing from the drain. **NOTE:** If water is flowing, the system may not have drained properly. If this is the case, follow all steps under the "Placing the System in Service" section, starting on page 10.

6. Record system air pressure at which the low-air alarm activates.

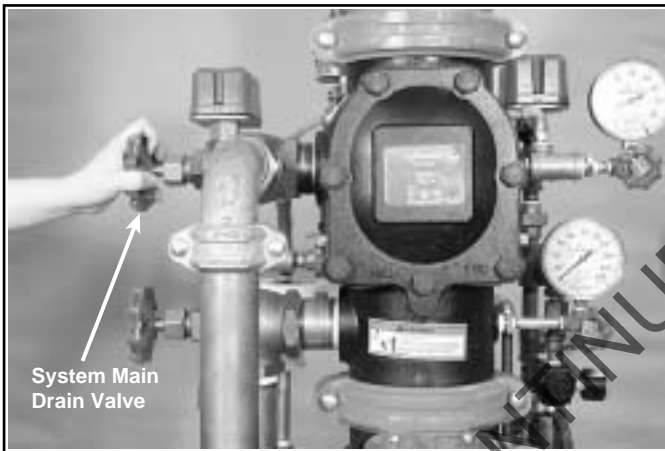

7. Close system main drain valve.

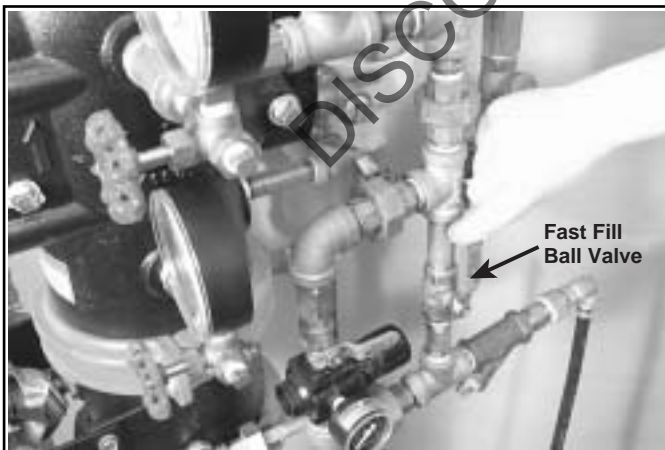

8. Open fast fill ball valve on air maintenance device. Bring pressure back up to normal system pressure.



9. Open water supply's main control valve.

10. Confirm that all valves are in their normal operating positions (refer to table below).

Valve	Normal Operating Position
Piston Charge Line Ball Valve	Open
Alarm Line Ball Valve	Open
Alarm Test Ball Valve	Closed
Alarm Drain Ball Valve	Closed

11. Notify the authority having jurisdiction, remote station alarm monitors, and those in the affected area that the valve is back in service.

12. Provide test results to the authority having jurisdiction, if required.

TRIP TESTS

Partial Flow Test

Partial flow tests are required to confirm proper valve operation; however, this test does not confirm full system operation. Victaulic recommends that the partial flow test be performed annually. **NOTE:** The authority having jurisdiction in your area may require that you perform this partial flow test on a more frequent basis. Verify these requirements by contacting the authority having jurisdiction in the affected area.

1. Notify the authority having jurisdiction, remote station alarm monitors, and those in the affected area that the partial flow test will be performed.

2. Record water supply pressure and system air pressure.

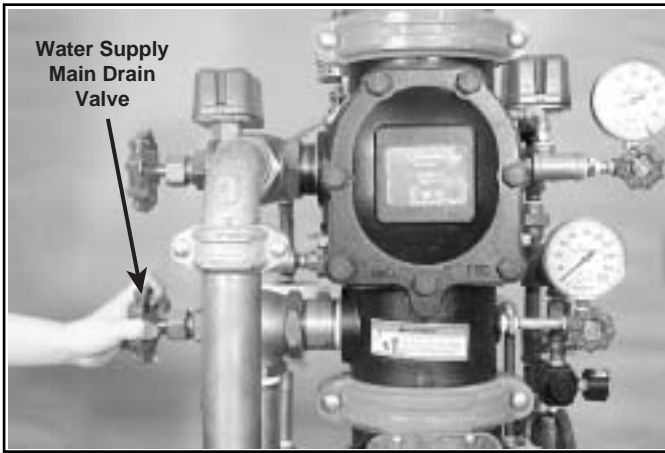

3. Open water supply main drain valve fully to flush water supply of any contaminants.

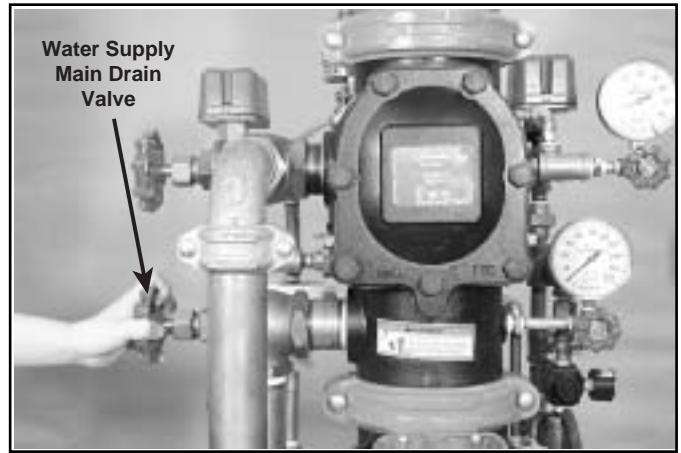

6. Close water supply main drain valve.



4. Close water supply's main control valve.

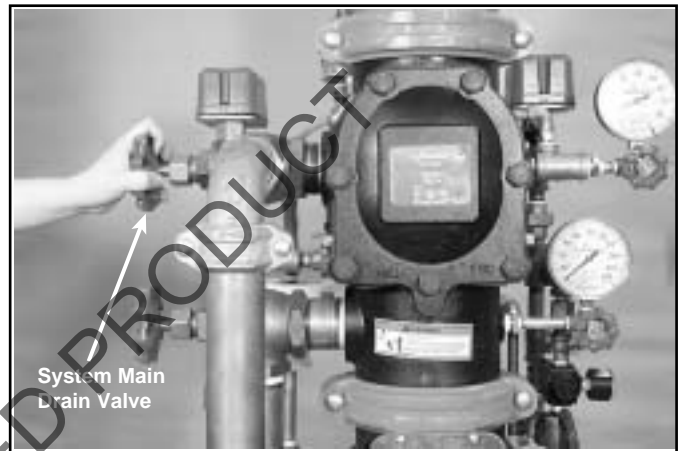

7. Open system main drain valve to simulate an open sprinkler head.

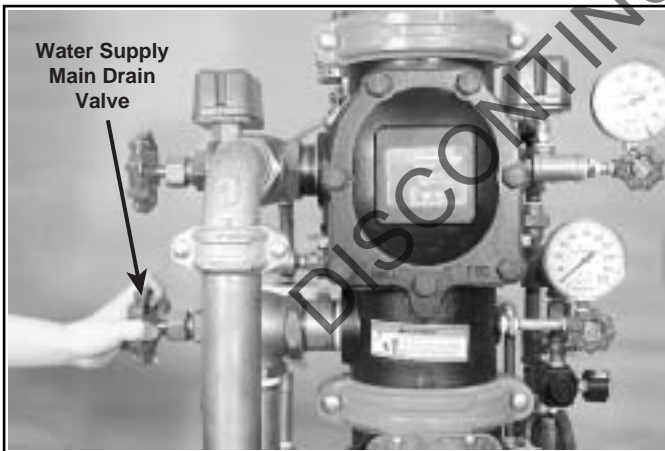

5. Open water supply main drain valves slowly until a small flow of water is detected in the water supply main drain.

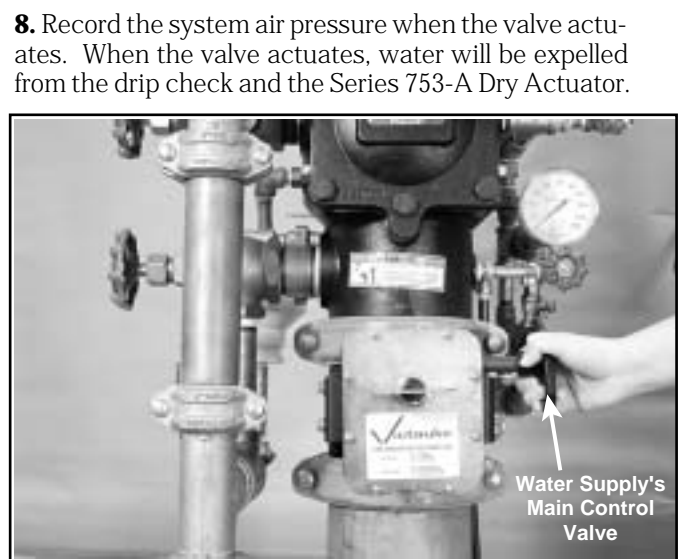

9. Confirm that the water supply's main control valve is closed.

8. Record the system air pressure when the valve actuates. When the valve actuates, water will be expelled from the drip check and the Series 753-A Dry Actuator.

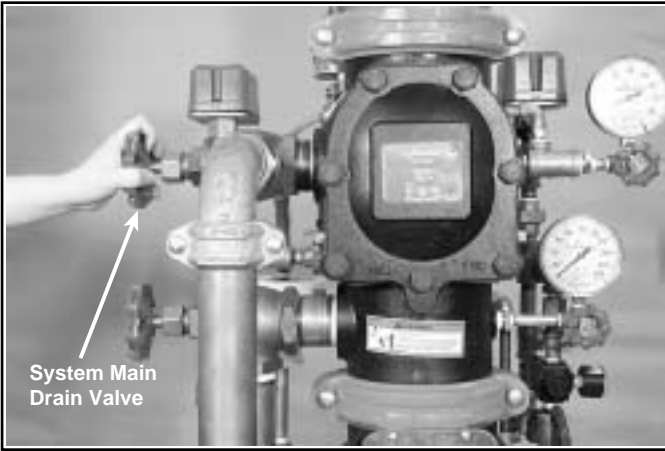

System Main Drain Valve

10. Close system main drain valve.

11. SHUT OFF AIR SUPPLY.

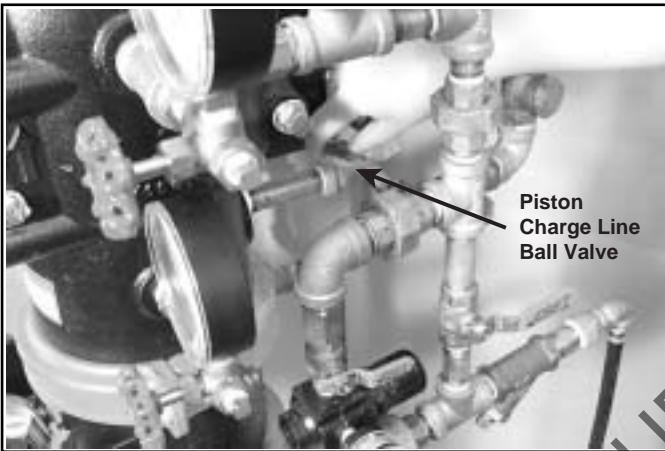

Piston Charge Line Ball Valve

12. Close piston charge line ball valve.

13. Confirm that system drains are shut and the system is free of leaks.

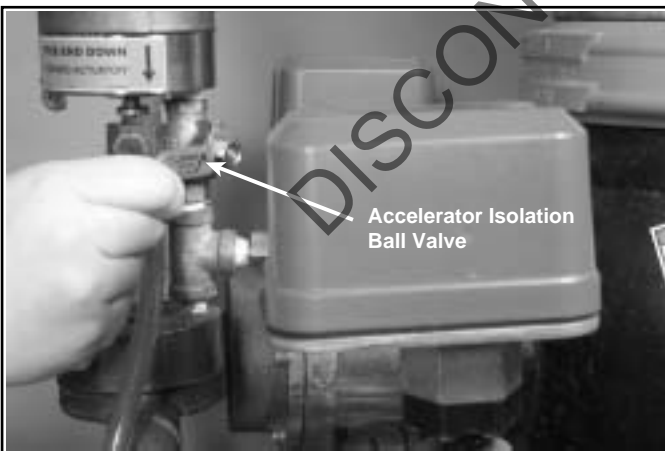

Accelerator Isolation Ball Valve

14. If a Series 746 Dry Accelerator is used, confirm that the isolation ball valve to the accelerator is closed.

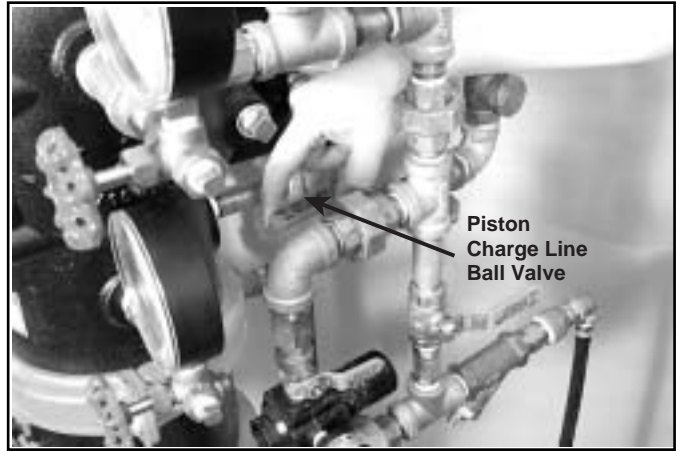

Piston Charge Line Ball Valve

15. Open piston charge line ball valve, and allow a steady flow of water to go through actuator.

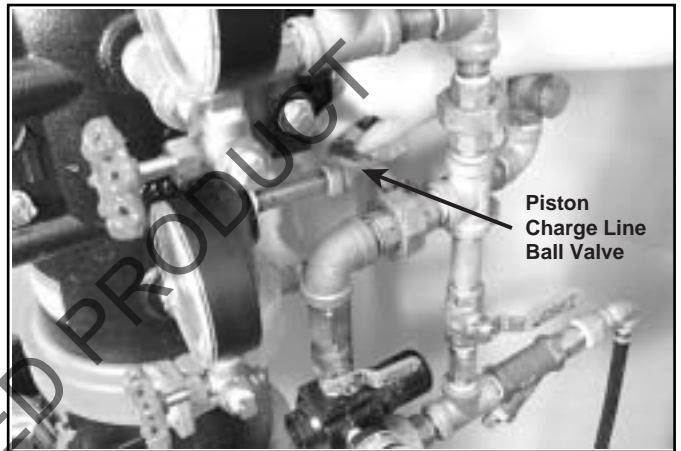

Piston Charge Line Ball Valve

16. Close piston charge line ball valve.

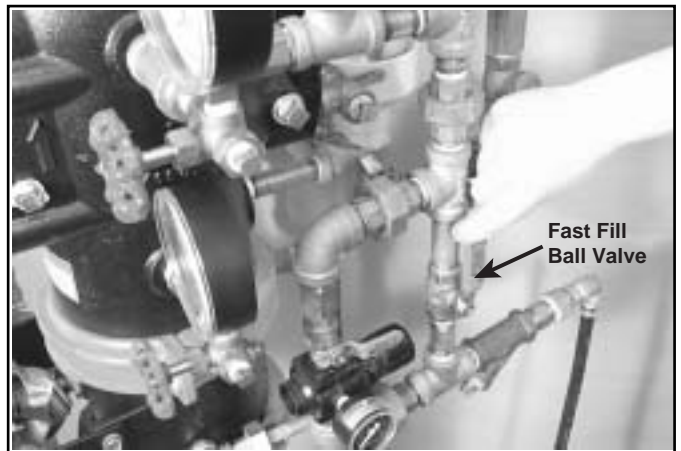

Fast Fill Ball Valve

17. Open fast fill ball valve on air maintenance device. Fill the system to the appropriate air pressure for the typical water supply pressure in the area. **NOTE:** Confirm that the system is charging by observing the air pressure gauge. If the gauge is not showing an increase in air pressure, there is a leak or an open line in the system.



17a. While system is charging, it may be necessary to push down on upper chamber seal of Series 753-A Dry Actuator.

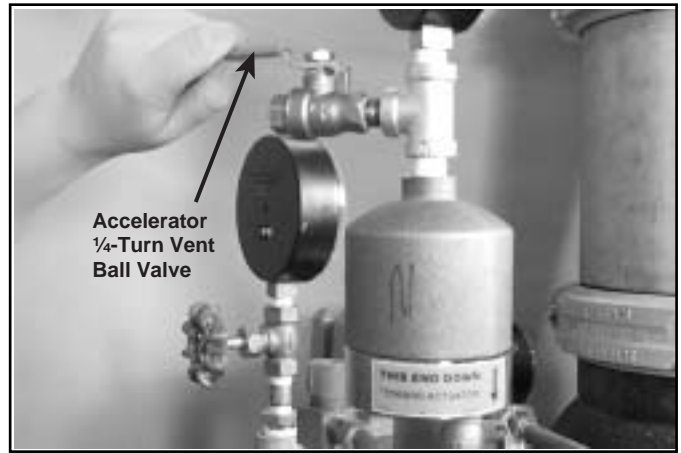

20. If a Series 746 Dry Accelerator is used, open the ¼-turn vent ball valve on the accelerator, as shown above.

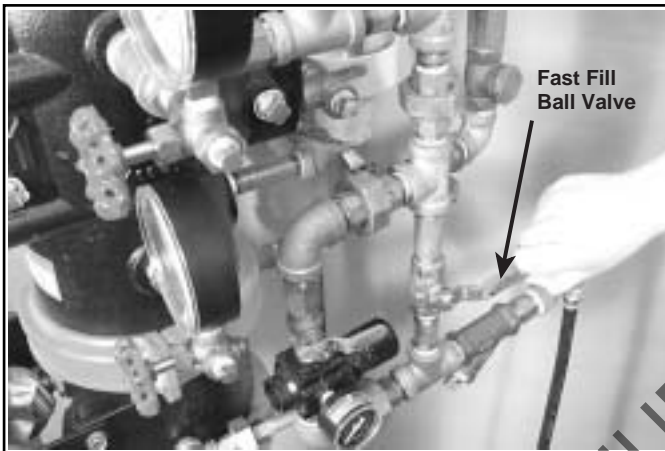

18. Once system air pressure is established, close fast fill ball valve.



20a. Open isolation ball valve to accelerator.

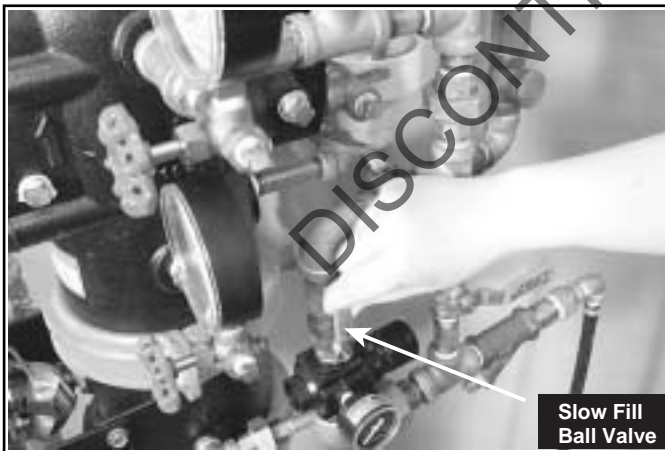

19. Open slow fill ball valve. Confirm air regulator is set to the proper system pressure.



20b. Close ¼-turn vent ball valve. This will set the accelerator.

21. Observe system air pressure over a 24-hour period to confirm system integrity. If there is degradation in system air pressure, find leaks and correct. **NOTE:** NFP requires less than 2-psi (14-kPa) leakage in 24 hours.

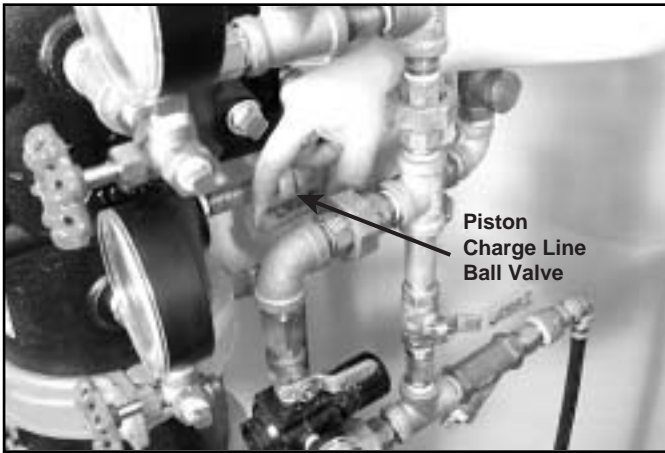

22. Open piston charge line ball valve.



23. Remove protective cap from Series 749 Auto Drain.

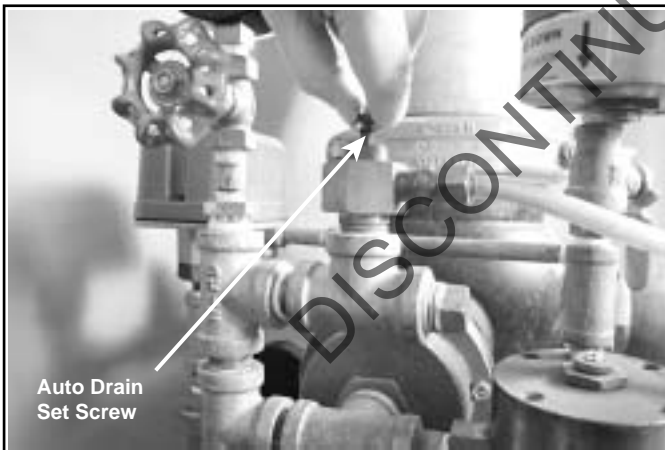

24. Pull up on auto drain set screw until auto drain is set (approximately 10 psi/69 kPa). Replace protective cap on auto drain.

⚠ WARNING

- Make sure the protective cap is replaced on the auto drain set screw to avoid accidental contact.

Hitting the set screw will cause the valve to trip, resulting in property damage.

25. Allow system to pressurize. Confirm that water pressure is established. The piston is now actuated, and the clapper will now be set.

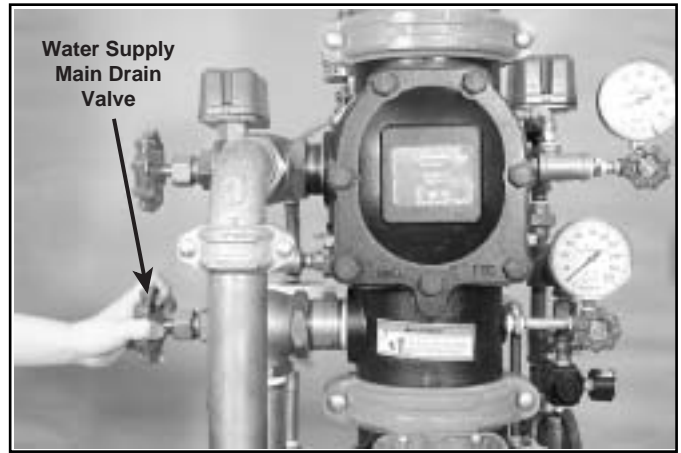

26. Open water supply main drain valve fully.

⚠ CAUTION

- Take precautions when opening the water supply main control valve, since water will flow from all open system valves.

Failure to do so could result in personal injury and property damage.



27. Open water supply's main control valves slowly until a steady flow of water flows from the open water supply main drain valve.

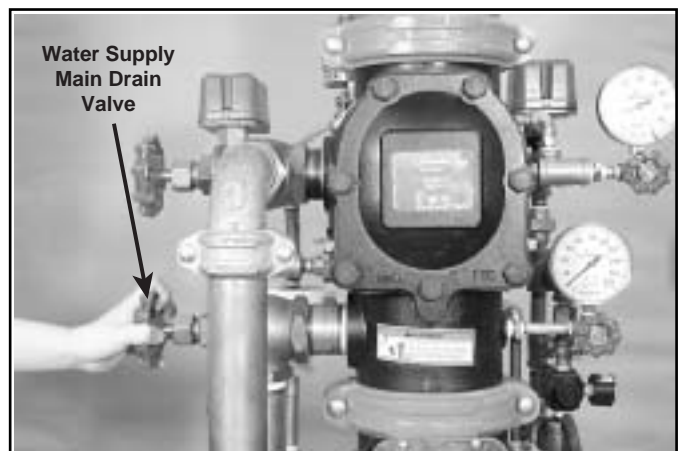

28. When a steady flow of water occurs, close the water supply main drain valve.

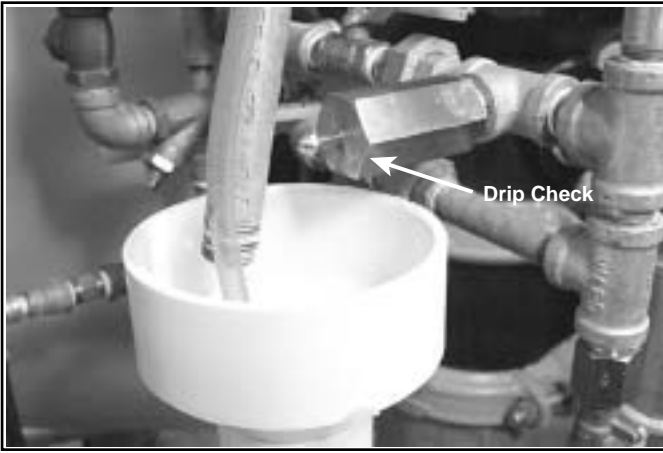

28a. Confirm that there is no leakage from the drip check located in the alarm line's piping. If water is flowing from drip check, close water supply's main control valve, and start over at step 1.



- 29.** Open water supply's main control valve fully.
- 30.** Record system air pressure and water supply pressure.
- 31.** Secure all valves in their normal operating positions (refer to table below).

Valve	Normal Operating Position
Piston Charge Line Ball Valve	Open
Alarm Line Ball Valve	Open
Alarm Test Ball Valve	Closed
Alarm Drain Ball Valve	Closed

- 32.** Notify the authority having jurisdiction, remote station alarm monitors, and those in the affected area that the valve is back in service.
- 33.** Provide test results to the authority having jurisdiction, if required.

Full Flow Test

Victaulic recommends full flow testing every three years. This test allows a full flow of water into the sprinkler system; therefore, this test must be performed in warm weather when there is no chance of freezing conditions. **NOTE:** The authority having jurisdiction in your area

may require that you perform this full flow test on a more frequent basis. Verify these requirements by contacting the authority having jurisdiction in the affected area.

- 1.** Notify the authority having jurisdiction, remote station alarm monitors, and those in the affected area that the partial flow test will be performed.
- 2.** Record water supply pressure and system air pressure.

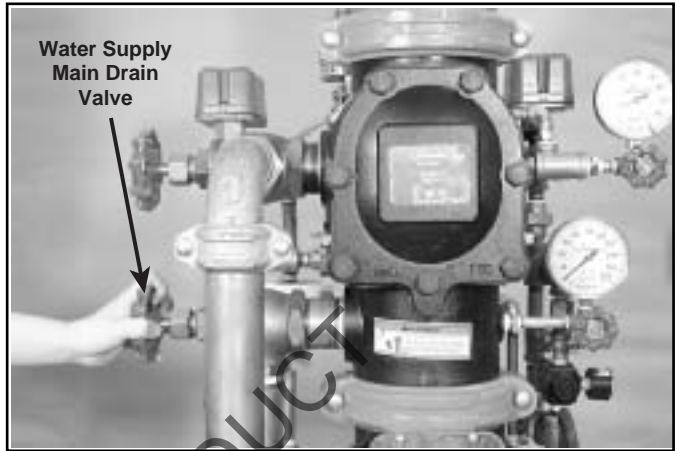

3. Open water supply main drain valve fully to flush water supply of any contaminants.

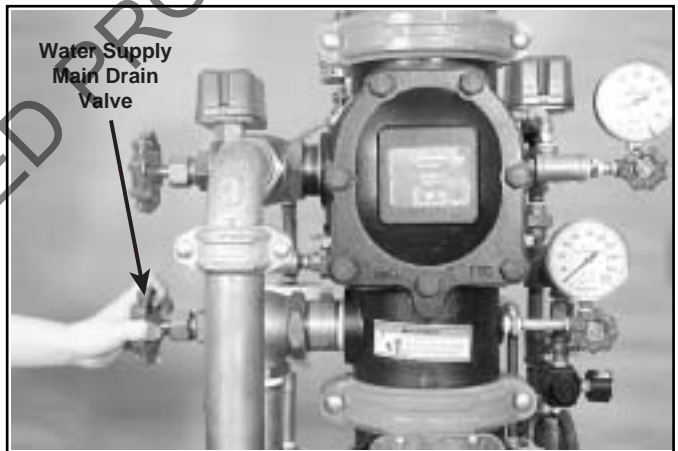

- 4.** Close water supply main drain valve.
- 5.** Open remote system test valve (inspector's test connection) to simulate the operation of a sprinkler head.
- 6.** Record the following:
 - a.** Time from opening remote system test valve (inspector's test connection) to operation of dry valve
 - b.** System air pressure when valve operated
 - c.** Time from opening remote system test valve (inspector's test connection) to when water flows from test connection's outlet
 - d.** All information required by the authority having jurisdiction
- 7.** Confirm that all alarms operate properly.
- 8.** Continue to run water until it is clear.



9. Close water supply's main control valve.

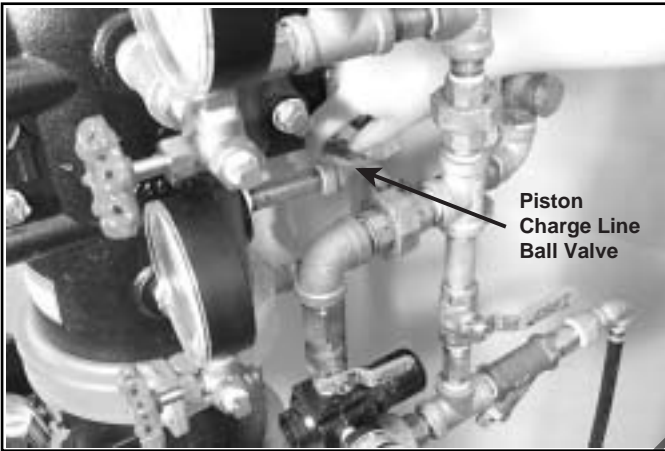

10. Close piston charge line ball valve.

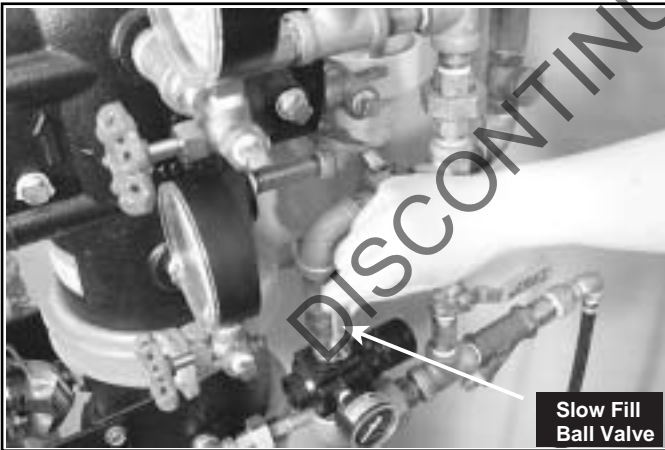

11. Close slow fill ball valve.

12. Close remote system test valve (inspector's test connection).

13. Perform steps 13 – 32 of the preceding "Partial Flow Test" section, starting on page 20.

REQUIRED INTERNAL INSPECTION

Inspect internal components on a frequency required by the current NFPA-25 code. The authority having jurisdiction in your area may require that you perform these inspections on a more frequent basis. Verify these requirements by contacting the authority having jurisdiction in the affected area.

⚠ WARNING



- Depressurize and drain piping systems before attempting to disassemble any Victaulic piping products.

Failure to follow this instruction could result in serious personal injury, property damage, and/or product damage.

⚠ WARNING



- Any activities that require taking the valve out of service may eliminate the fire protection provided.
 - Before servicing or testing the system, notify the authority having jurisdiction.
 - Consideration of a fire patrol should be given in the affected areas.
- Failure to follow these instructions could result in serious personal injury and/or property damage.

1. Notify the authority having jurisdiction, remote station alarm monitors, and those in the affected area that the system is being taken out of service.



2. Close water supply's main control valve to take the system out of service.

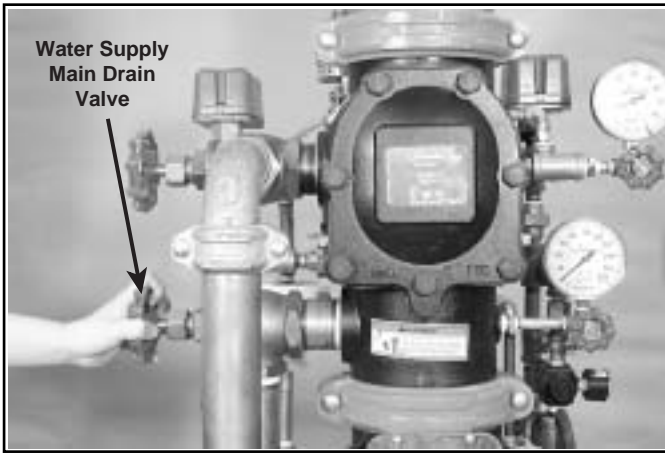

3. Open water supply main drain valve, as shown above.

4. Confirm that no water is flowing from water supply main drain.

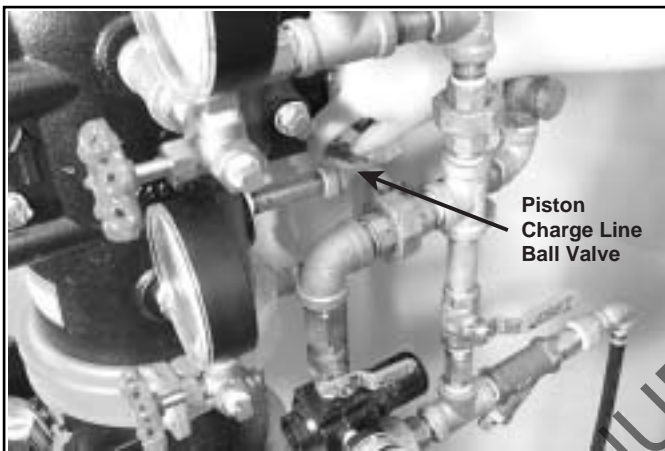

5. Close piston charge line ball valve.

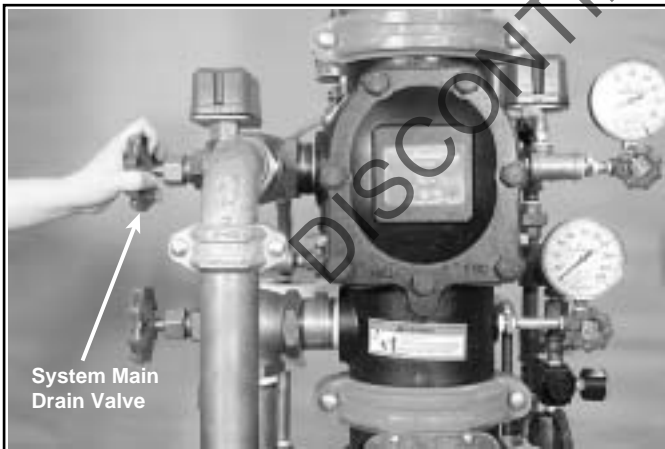

6. Open system main drain valve to drain any water that has accumulated and to release system air pressure.
NOTE: If the system has operated, open the remote system test valve (inspector's test connection) and any auxiliary drain valves.

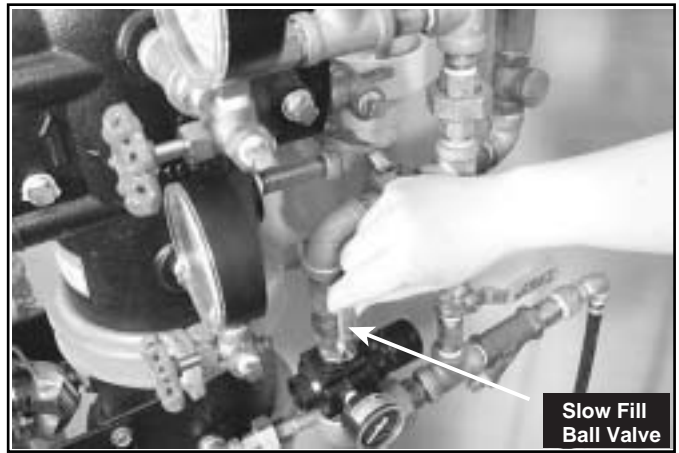

7. Close slow fill ball valve on air maintenance device.

! WARNING

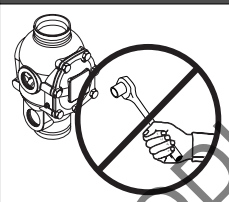

- Make sure valve is depressurized and drained before removing cover plate bolts.

The cover plate will blow off if these bolts are removed while the valve is pressurized, resulting in serious personal injury and/or property damage.



8. After all pressure is released from the system, loosen cover plate bolts, and remove cover plate.

! CAUTION

- Do not use solvents or abrasives on or near the valve body seat ring.

Failure to follow this instruction could prevent the clapper from sealing properly, resulting in improper operation, valve leakage, and/or property damage.



9. Rotate clapper out of valve body. Inspect clapper seal and seal retaining ring. Wipe away any contaminants, dirt, and mineral deposits. Clean any holes in the valve body seat ring that are plugged. **DO NOT USE SOLVENTS OR ABRASIVES.**



10. Inspect clapper for freedom of movement and physical damage. Replace any damaged or worn parts by following the applicable instructions in the "Maintenance" section, starting on this page.

11. Re-install cover plate by following the "Installing Cover Plate Gasket and Cover Plate" section, starting on page 29.

MAINTENANCE

The following steps instruct on how to remove and replace internal valve components. It is important that care be taken to avoid damage to parts.

⚠ WARNING



- Depressurize and drain piping systems before attempting to disassemble any Victaulic piping products.
- Failure to follow this instruction could result in serious personal injury, property damage, and/or product damage.

⚠ WARNING



- Any activities that require taking the valve out of service may eliminate the fire protection provided.
 - Before servicing or testing the system, notify the authority having jurisdiction.
 - Consideration of a fire patrol should be given in the affected areas.
- Failure to follow these instructions could result in serious personal injury and/or property damage.

Removing and Replacing Clapper Seal

1. Perform steps 1-9 of the "Required Internal Inspection" section, starting on page 24.



2. Remove seal assembly bolt/bolt seal from clapper seal, as shown above.

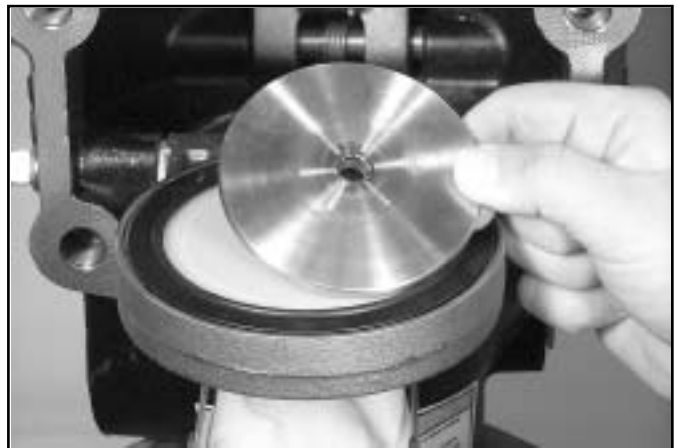

3. Remove seal retaining ring.

CAUTION

- DO NOT pry the seal washer out of the clapper seal from the inner hole. Failure to follow this instruction could damage the seal washer, resulting in improper clapper sealing and property damage.



4. Pry edge of seal washer from inside of clapper seal, as shown above. DO NOT pry the seal washer out from the inner hole. Dry up any water that is under the seal washer.



5. Remove seal washer from clapper seal.



6. Pry clapper seal, along with seal ring, out of clapper, as shown above. Inspect seal. If seal is torn or worn, replace.

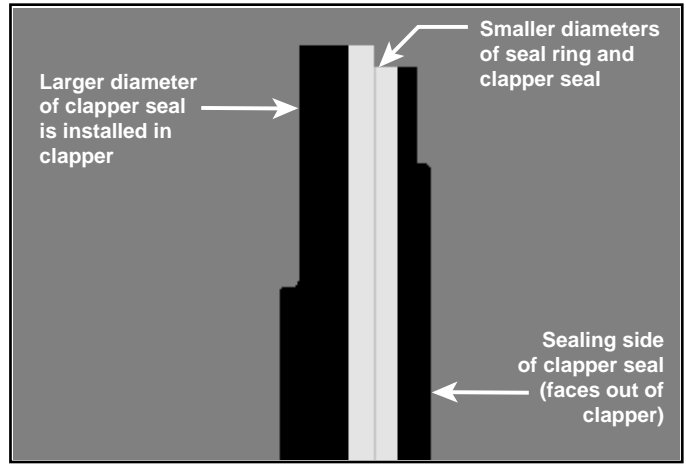

6a. If seal ring was removed from clapper seal in previous step: Re-insert ring carefully underneath outer lip of clapper seal. Make sure smaller diameter of seal ring is toward sealing surface of clapper seal, as shown above.



7. Insert seal washer carefully underneath sealing lip of gasket.

8. Make sure clapper is free of contaminants, dirt, and mineral deposits.



9. Install clapper seal into clapper carefully. Make sure seal ring snaps into clapper completely.

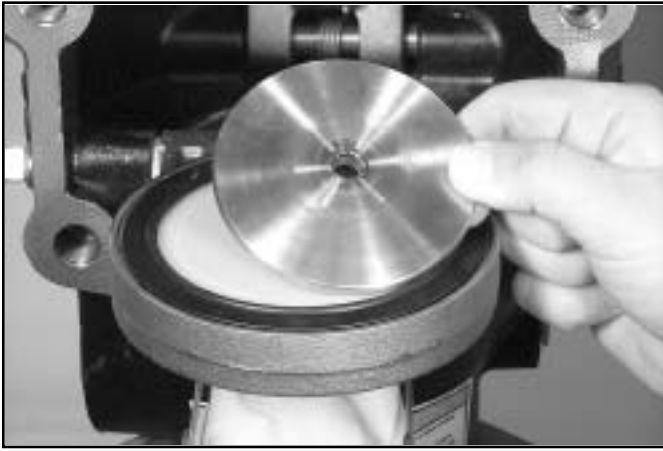

10. Place seal retaining ring onto seal washer of clapper seal.

⚠ CAUTION

- Use only Victaulic-supplied replacement seal assembly bolt/bolt seal when reassembling clapper.

Failure to follow this instruction could result in property damage and/or valve leakage.



11. Install seal assembly bolt/bolt seal through seal retaining ring and clapper. Tighten seal assembly bolt/bolt seal sufficiently, and apply an additional $\frac{1}{4}$ turn to ensure a proper seal.

Removing and Replacing Clapper Assembly

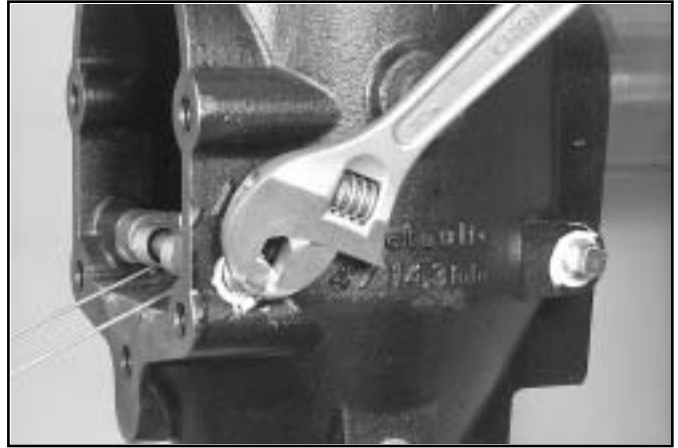

1. Remove clapper shaft-retaining plugs from valve body.



2. Remove clapper shaft, as shown above. **NOTE:** As the shaft is being removed, the two spacers and clapper spring, shown above, will drop out of position. Keep the spacers and clapper spring for re-installation.

3. Remove clapper from valve body.

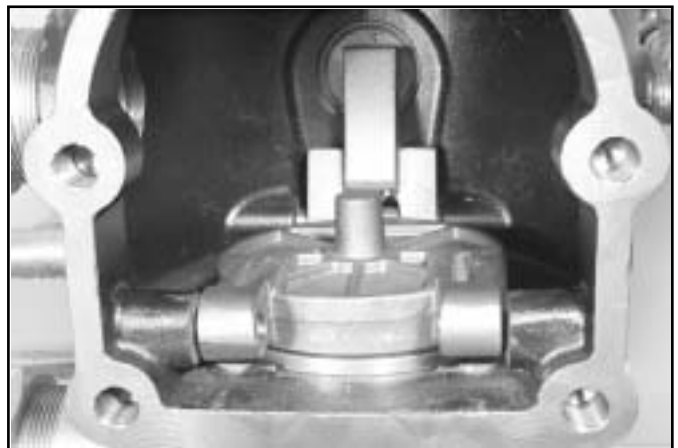

4. Place new clapper assembly onto the valve body seat ring so that the holes in the clapper arms align with the holes in the valve body, as shown above.

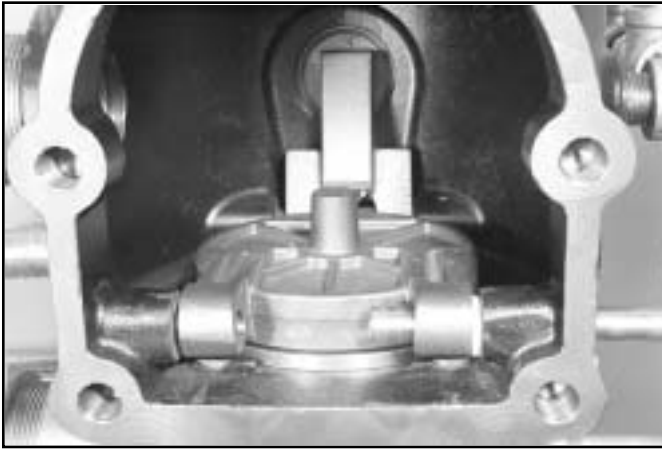

5. Start clapper shaft into valve body, and place one spacer between clapper and valve body, as shown above.



8. Install clapper shaft-retaining plugs into valve body.

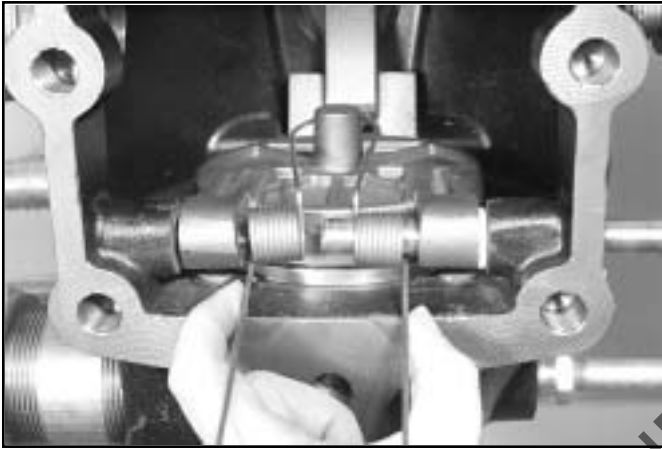

6. Install spring onto clapper shaft, making sure loop is toward clapper, as shown above.



9. Check clapper for freedom of movement.

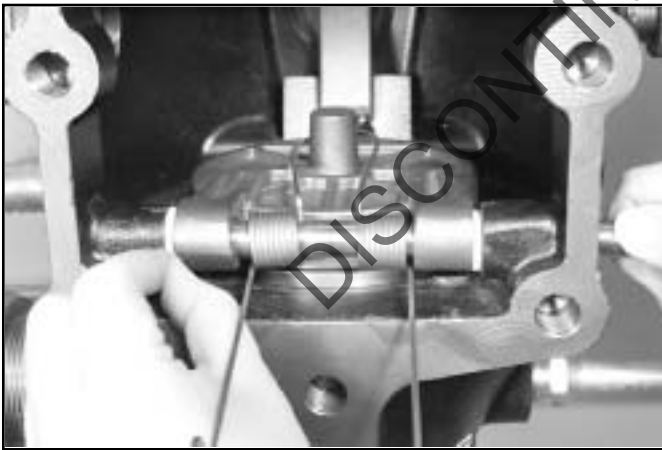

7. Place other spacer between clapper and valve body, and finish inserting clapper shaft through clapper arm and valve body, as shown above.

Installing Cover Plate Gasket and Cover Plate

1. Verify cover plate gasket is in good condition. If gasket is torn or worn, replace with a new, Victaulic-supplied gasket.



2. Align cover plate gasket holes with holes in cover plate.



3. Insert one cover bolt through cover plate and cover gasket to ease alignment.



4. Align cover plate/cover plate gasket to valve. Make sure spring arms are rotated to their installed position. Insert all cover bolts and hand-tighten.

! CAUTION

- DO NOT over-tighten cover bolts.

Failure to follow this instruction could cause damage to cover plate gasket, resulting in valve leakage.

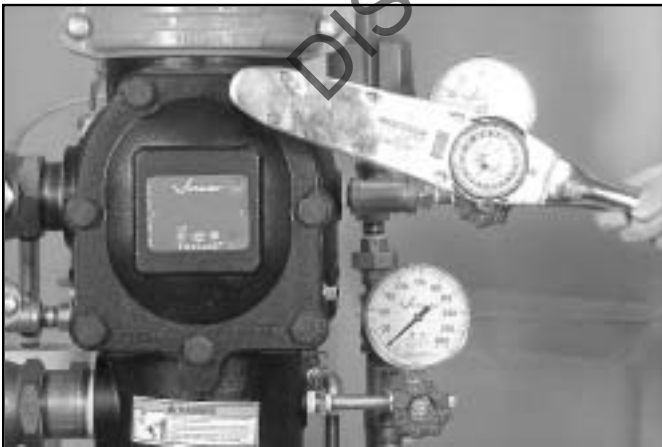

5. Torque all cover bolts in an even, crossing pattern. Refer to the "Recommended Cover Bolt Torque" chart on this page for the required torque values. DO NOT over-tighten these cover bolts.

Recommended Cover Bolt Torque

Size (inches)	Torque (ft-lbs)	Size (inches)	Torque (ft-lbs)	Size (inches)	Torque (ft-lbs)
1½	30	76,1 mm	60	6	115
2	30	3	60	165,1 mm	115
2½	60	4	100	8	100

6. Place system back in service by following the "Placing the System in Service" section, starting on page 10.

Removing and Replacing Piston Assembly

! WARNING

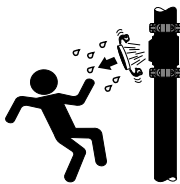

- Depressurize and drain piping systems before attempting to disassemble any Victaulic piping products.

Failure to follow this instruction could result in serious personal injury, property damage, and/or product damage.

! WARNING



- Any activities that require taking the valve out of service may eliminate the fire protection provided.
- Before servicing or testing the system, notify the authority having jurisdiction.
- Consideration of a fire patrol should be given in the affected areas.

Failure to follow these instructions could result in serious personal injury and/or property damage.

! CAUTION

- DO NOT extend piston manually. Manually extending the piston could damage the internal diaphragm.

Failure to follow this instruction could result in improper valve operation and/or valve leakage.

1. Disconnect trim from piston.

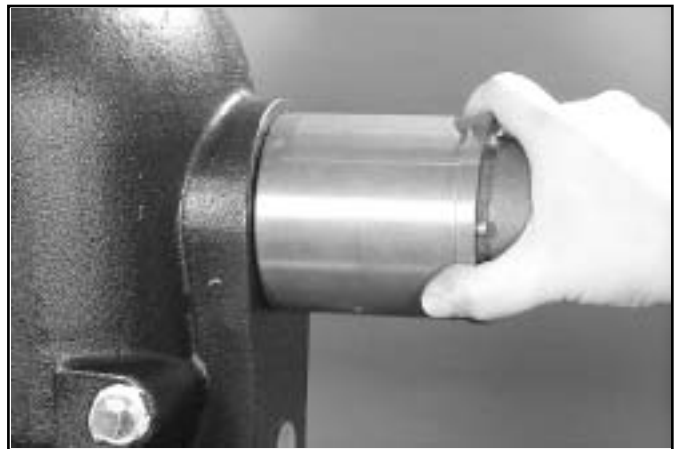

2. Unscrew piston from valve body.

3. Clean piston seating area of valve body and threaded hole to make sure any debris is removed.

4. Replace piston with a new, Victaulic-supplied assembly. Make sure o-ring is installed flush to piston body.

5. Screw piston into valve body until metal-to-metal contact occurs.

6. Re-attach trim, per the applicable trim drawing.

TROUBLESHOOTING – SERIES 753-A DRY ACTUATOR

Problem	Possible Cause	Solution
Air leaks from upper chamber seal when pushing down on vent during setup.	Adjustment nut on vent seal is set too low.	Turn adjustment nut 1/8-turn counterclockwise. Try to set dry actuator again. If it still does not set, repeat this adjustment procedure until dry actuator sets up.
After dry actuator is set and the auto drain set screw is pulled up, water leaks through lower chamber while the piston charge line is pressurizing.	Adjustment nut on vent seal is set too high.	Turn adjustment nut 1/8-turn clockwise. Try to set dry actuator again. If it still does not set, repeat this adjustment procedure until dry actuator sets up.
	Lower seat/water seal is damaged.	Contact Victaulic.
Air leaks out of waterside drain of dry actuator.	Torn diaphragm.	Torn diaphragm.
Cannot pressurize air side of dry actuator.	Blockage in airline.	Remove and clean airline strainer and 1/16-inch airline restrictor.

TROUBLESHOOTING – SERIES 746 DRY ACCELERATOR

Problem	Possible Cause	Solution
The system valve operates without sprinkler activation.	Loss of air pressure in the lower inlet chamber.	Check for air loss at lower chamber seal. If a leak is present, turn adjustment nut counterclockwise to seal. Check for any leaks in system and trim. Confirm proper operation of air maintenance device.
Dry accelerator does not operate within a 5-psi (34 kPa) pressure drop in system air pressure.	Loss of air pressure in upper air chamber of dry accelerator.	Apply soapy water to all dry accelerator joints, and check for leaks. Repair any leaks and re-test. Make sure there are no restrictions in the inspector's test connection.
	Air decay rate of system is too slow.	If the above procedures do not work, contact Victaulic.
Dry accelerator does not set up properly (cannot get pressure on upper gauge, and button pops up immediately when pressure is introduced).	Dry accelerator is installed upside down.	Remove dry accelerator from trim, and turn unit around so that the button is facing down (toward dry actuator).

TROUBLESHOOTING – SYSTEM

Problem	Possible Cause	Solution
Valve operates without sprinkler activation.	Loss of air pressure in system or trim.	Check for system leaks. Confirm proper operation of air maintenance device. Consider installing a low-air supervisory switch.
	Pressure switch on air compressor is set low, or compressor is not operating.	Increase "ON" setting on pressure switch, and check compressor for proper operation.
Water leaking from drip check valve.	Water is getting past clapper seal and into intermediate chamber.	Check clapper seal and valve body seat ring for physical damage or foreign material. Inspect clapper seal to make sure no water is under seal. If water is present, remove and replace seal, per instructions on page 26.
	Water is under clapper seal.	
Air leaking from drip check valve.	Air is getting past clapper seal and into intermediate chamber.	Check clapper seal and valve body seat ring for physical damage or foreign material. Inspect clapper seal to make sure no water is under seal. If water is present, remove and replace seal, per instructions on page 26.
	Water is under clapper seal.	
Clapper will not latch closed.	No air pressure on dry actuator.	Refer to troubleshooting for Series 753-A Dry Actuator.
	No water pressure on piston.	Check water pressure in piston charge line.
	Auto drain is not set.	Set auto drain.
Water leaking from piston assembly.	Diaphragm is damaged.	Contact Victaulic.
Air leaking from piston assembly.	Piston rod seal is damaged.	Contact Victaulic.

DISCONTINUED PRODUCT

WARRANTY

We warrant all products to be free from defects in materials and workmanship under normal conditions of use and service. Our obligation under this warranty is limited to repairing or replacing at our option at our factory any product which shall within one year after delivery to original buyer be returned with transportation charges prepaid, and which our examination shall show to our satisfaction to have been defective.

THIS WARRANTY IS MADE EXPRESSLY IN LIEU OF ANY OTHER WARRANTIES, EXPRESS OR IMPLIED, INCLUDING ANY IMPLIED WARRANTY OF MERCHANTABILITY OR FITNESS FOR A PARTICULAR PURPOSE. THE BUYER'S SOLE AND EXCLUSIVE REMEDY SHALL BE FOR THE REPAIR OR REPLACEMENT OF DEFECTIVE PRODUCTS AS PROVIDED HEREIN. THE BUYER AGREES THAT NO OTHER REMEDY (INCLUDING, BUT NOT LIMITED TO, INCIDENTAL OR CONSEQUENTIAL DAMAGES FOR LOST PROFITS, LOST SALES, INJURY TO PERSON OR PROPERTY OR ANY OTHER INCIDENTAL OR CONSEQUENTIAL LOSS) SHALL BE AVAILABLE TO HIM.

Victaulic neither assumes nor authorizes any person to assume for it any other liability in connection with the sale of such products.

This warranty shall not apply to any product which has been subject to misuse, negligence or accident, which has been repaired or altered in any manner outside of Victaulic's factory or which has been used in a manner contrary to Victaulic's instructions or recommendations. Victaulic shall not be responsible for design errors due to inaccurate or incomplete information supplied by Buyer or its representatives.

EFFECTIVE OCTOBER 15, 1997

This product shall be manufactured by Victaulic Company. All products to be installed in accordance with current Victaulic installation/assembly instructions. Victaulic reserves the right to change product specifications, designs and standard equipment without notice and without incurring obligations.



www.victaulic.com
 Customer Inquiries: pickvic@victaulic.com
 Literature Requests: victaulic@victaulic.com

WORLD HEADQUARTERS
 P.O. Box 31 • Easton, PA 18044-0031
 4901 Kesslersville Road • Easton, PA, USA 18040
 Phone: 610/559-3300 • FAX: 610/250-8817



CUSTOMER CARE CENTER
 Phone: 1-800-PICK-VIC (1-800-742-5842) • e-mail: pickvic@victaulic.com

VICTAULIC COMPANY OF AMERICA
 P.O. Box 31 • Easton, PA 18044-0031
 Phone: 610/559-3300 • Fax: 610/250-8817

**Fire Protection Division
 Customer Care Centers**

- **SOUTHEAST FIRE PROTECTION**
 Phone: 877/773-8322 • Fax: 877/776-9769
- **NORTHEAST FIRE PROTECTION**
 Phone: 888/265-0805 • Fax: 888/265-0918
- **CENTRAL FIRE PROTECTION**
 Phone: 888/448-3534 • Fax: 888/448-3595
- **WESTERN FIRE PROTECTION**
 Phone: 877/487-7231 • Fax: 877/487-7232

Victaulic Tool Company
 P.O. Box 31 • Easton, PA 18044-0031
 Phone: 610/559-3300 • Fax: 610/923-3090

Victaulic Municipal Division
 1818 Vultee Street • Allentown, PA 18103
 Phone: 610/559-3488 • Fax: 610/923-3170

Victaulic Construction Piping Services
 1818 Vultee Street • Allentown, PA 18103
 Phone: 610/559-3488 • Fax: 610/923-3170

United States Distribution Centers

- **NEW ENGLAND/NEW YORK METRO**
 4901 Kesslersville Road • Easton, PA 18040
 Cust.Care: 800/742-5842 • Cust. Fax: 800/437-6573
- **SOUTHEAST**
 650 Coastline Drive • Yulee, FL 32097
 Cust.Care: 800/742-5842 • Cust. Fax: 888/201-3468
- **MIDWEST**
 730 Thomas Drive • Bensenville, IL 60106
 Cust.Care: 800/742-5842 • Cust. Fax: 888/265-2018
- **GREAT LAKES**
 23107 Commerce Drive • Farmington Hills, MI 48335
 Cust.Care: 800/742-5842 • Cust. Fax: 800/564-0119
- **CENTRAL STATES**
 5900 Deramus Avenue • Kansas City, MO 64120
 Cust.Care: 800/742-5842 • Cust. Fax: 888/448-3540
- **MID-CONTINENT**
 7177 Railspur Street • Houston, TX 77078
 Cust.Care: 800/742-5842 • Cust. Fax: 888/448-3537
- **PERMIAN BASIN**
 2628 Remington Road • Odessa, TX 79763
 Local Tel: 915/332-1489 • Local Fax: 915/332-4924
- **ROCKY MOUNTAIN**
 5045 Paris Street • Denver, CO 80239
 Cust.Care: 800/742-5842 • Cust. Fax: 888/448-3528
- **PACIFIC - NORTH**
 22633 83rd Ave. So. • Kent, WA 98032
 Cust.Care: 800/742-5842 • Cust. Fax: 888/448-3530
- **MID-ATLANTIC**
 4901 Kesslersville Road • Easton, PA 18040
 Cust.Care: 800/742-5842 • Cust. Fax: 800/696-6447
- **PACIFIC - SOUTH**
 20934 So. Santa Fe Ave. • Long Beach, CA 90810
 Cust.Care: 800/742-5842 • Cust. Fax: 800/448-3542

VICTAULIC COMPANY OF CANADA

65 Worcester Road • Rexdale, Ontario • Canada M9W 5N7
 Phone: 416/675-5575 • FAX: 416/675-5565 • e-mail: viccanada@victaulic.com

Canadian Sales Offices and Service Centers

- **EASTERN**
 975 rue Selkirk • Pointe Claire, QC H9R 4S4
 Phone: 514/426-3500 • FAX: 514/426-2818
- **ONTARIO - NORTH**
 1070 Elisabetha Street • Sudbury, ON P3A 5K2
 Phone: 705/560-9595 • FAX: 705/560-9490
- **PACIFIC**
 Unit 5, 7560 Vantage Way • Delta, BC V4G 1H1
 Phone: 604/940-3301 • FAX: 604/940-3360
- **ONTARIO - SOUTH**
 65 Worcester Road • Rexdale, ON M9W 5N7
 Phone: 416/675-5575 • FAX: 416/675-5729
- **WESTERN**
 11659 180th Street NW • Edmonton, AB T5S 2H6
 Phone: 780/452-0680 • FAX: 780/452-2430

VICTAULIC INTERNATIONAL
 P.O. Box 31 • Easton, PA, USA 18044-0031
 4901 Kesslersville Road • Easton, PA, USA 18040
 Phone: 610/559-3300 • FAX: 610/559-3608
 e-mail: vicintl@victaulic.com

VICTAULIC AMERICA LATINA
 P.O. Box 31 • Easton, PA, USA 18044-0031
 4901 Kesslersville Road • Easton, PA, USA 18040
 Phone: 610/559-3300 • FAX: 610/559-3608
 e-mail: vical@victaulic.com

VICTAULIC EUROPE
 Prijkelstraat 36
 9810 Nazareth Belgium
 Phone: 011-32-93-811500 • FAX: 011-32-93-804438

VICTAULIC ASIA-PACIFIC
 541 Orchard Road, #14-02, Liat Towers
 Singapore 238881
 Phone: 011-65-235-3035 • FAX: 011-65-235-0535