

Style 997 Transition Coupling HDPE Plastic to Steel

PRODUCT DESCRIPTION



The Victaulic Style 997 Transition coupling is the fastest and easiest way to join plain end HDPE pipe to grooved IPS pipe, valves and fittings. Designed for use with HDPE (high density polyethylene/ polybutylene conforming to ASTM D-2447, D-3000, D-3035 or F-714 at ambient temperatures) pipe of wall thicknesses from SDR 32.5 to 7.3. As with all Victaulic HDPE products, Style 997 has integral rows of gripping teeth on the HDPE side of the housing which bite into the HDPE pipe around the entire circumference.

The grooved side has a conventional key section designed to engage standard roll or cut grooved IPS pipe of the same size as the mating HDPE pipe.

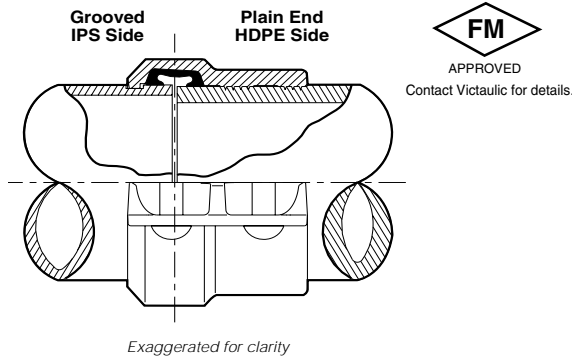

DIMENSIONS

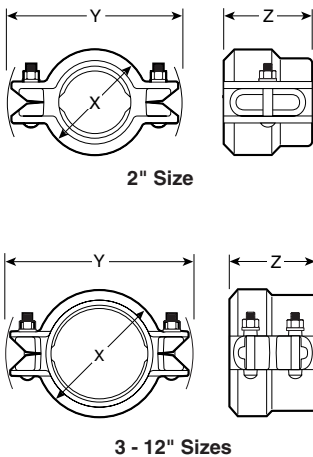

Valve Size		Dimensions – Inches/millimeters			Bolt Data		Aprx. Wgt. Each Lbs. kg
Nominal Dia. In./mm	Actual Out. Dia. In./mm	X	Y	Z	Quantity	Size Inches	
2 50	2.375 60,3	3.31 84	5.22 133	2.78 71	2	3/8 x 2	3.0 1,4
3 80	3.500 88,9	4.38 111	6.99 178	3.20 81	4	1/2 x 2 3/4	6.6 3,0
4 100	4.500 114,3	5.68 144	8.25 210	3.90 99	4	1/2 x 2 3/4	8.7 4,0
5 125	5.563 141,3	6.75 172	9.77 248	3.97 101	4	5/8 x 3 1/4	11.5 5,2
6 150	6.625 168,3	7.84 199	11.25 286	4.00 102	4	5/8 x 3 1/4	14.8 6,7
8 200	8.625 219,1	10.18 259	13.96 355	4.16 106	4	5/8 x 3 1/4	21.7 9,8
10 250	10.750 273,0	12.63 321	16.81 427	4.56 116	4	7/8 x 5 1/2	34.3 15,6
12 300	12.750 323,9	14.58 370	18.76 477	4.85 123	4	7/8 x 5 1/2	37.5 17,0

This product shall be manufactured by Victaulic Company. All products to be installed in accordance with current Victaulic installation/assembly instructions. Victaulic reserves the right to change product specifications, designs and standard equipment without notice and without incurring obligations.

PERFORMANCE

Victaulic HDPE products are designed to mechanically join HDPE (*high density polyethylene/ polybutylene conforming to ASTM D-2447, D-3000, D-3035 or F-714) pipe of wall thicknesses from SDR 32.5 to 7.3. Victaulic HDPE products have integral rows of gripping teeth in each side of the housing which bite into HDPE pipe around the entire circumference. This eliminates special heat fusion, solvent joining or special adapters. The toothed gripping ends of Victaulic HDPE products are not intended for use on PVC pipe or other materials. Victaulic lubricant should not be used with HDPE pipe.

HDPE pipe brands we have tested indicate that the working pressure of Victaulic HDPE products are dictated by the working pressure of the pipe. The pipe manufacturers listing is dependent upon wall thicknesses, pipe composition and temperature. Pipe tolerances shown in the charts are *at +70°F (+21°C) and for rigid pipe with SDR of 20 or lower.

*At ambient temperatures.

⚠ CAUTION

- Victaulic Style 997 couplings are qualified for use on HDPE ONLY on the toothed gripping end. The toothed gripping end should not be used on other plastic materials.
- Failure to follow this instruction could result in personal injury, improper installation, leakage or joint separation.

Pipe Size		Inches/millimeters		
Nominal Diameter Inches/mm	Actual Outside Diameter Inches/mm	Tolerance*		Maximum Out of Round Tolerance *
		Max.	Min.	
2 50	2.375 60,3	± 0.012 0,31		± 0.004 1,016
3 80	3.500 88,9	± 0.015 0,38		± 0.040 1,016
4 100	4.500 114,3	± 0.020 0,51		± 0.040 1,016
5 125	5.563 141,3	± 0.025 0,64		± 0.050 1,270
6 150	6.625 168,3	± 0.035 0,89		± 0.050 1,270
8 200	8.625 219,1	+ 0.062 1,57	- 0.031 0,79	± 0.075 1,905
10 250	10.750 273,0	+ 0.062 1,57	- 0.031 0,79	± 0.075 1,905
12 300	12.750 323,9	+ 0.062 1,57	- 0.031 0,79	± 0.075 1,905

*At ambient temperatures.

MATERIAL SPECIFICATIONS

Housing: Ductile iron conforming to ASTM A-536, grade 65-45-12. Ductile iron conforming to ASTM A-395, grade 65-45-15, is available upon special request.

Housing Coating: Orange enamel

- **Optional:** Hot dip galvanized
- **Optional:** Zinc electroplated

Gasket: (specify choice*)

- **Grade "E" EPDM**
EPDM (Green color code). Temperature range -30°F to +230°F (-34°C to +110°C). Recommended for cold and hot water service within the specified temperature range plus a variety of dilute acids, oil-free air and many chemical services. UL classified in accordance with ANSI/NSF 61 for cold +86°F (+30°C) and hot +180°F (+82°C) potable water service. NOT RECOMMENDED FOR PETROLEUM SERVICES.
- **Grade "T" nitrile**
Nitrile (Orange color code). Temperature range -20°F to +180°F (-29°C to +82°C). Recommended for petroleum products, air with oil vapors, vegetable and mineral oils within the specified temperature range. Not recommended for hot water services over +150°F (+66°C) or for hot dry air over +140°F (+60°C).

*Services listed are General Service Recommendations only. It should be noted that there are services for which these gaskets are not recommended. Reference should always be made to the latest Victaulic Gasket Selection Guide for specific gasket service recommendations and for a listing of services which are not recommended.

Bolts/Nuts: Heat-treated plated carbon steel, trackhead meeting the physical and chemical requirements of ASTM A-449 and physical requirements of ASTM A-183.

- **Optional:** Type 304 or 316 stainless steel.

Washers: Hardened steel flat washers meeting ASTM-F436 Type 3 requirements.