

Series 7C7 Air Maintenance/Compressor Assembly

⚠ WARNING



- Read and understand all instructions before attempting to install any Victaulic products.
 - Always verify that the piping system has been completely depressurized and drained immediately prior to installation, removal, adjustment, or maintenance of any Victaulic products.
 - Wear safety glasses, hardhat, and foot protection.
- Failure to follow these instructions could result in death or serious personal injury and property damage.

- Series 7C7 Air Maintenance/Compressor assemblies shall be used only in fire protection systems that are designed and installed in accordance with current, applicable National Fire Protection Association (NFPA 13, 13D, 13R, etc.) standards, or equivalent standards, and in accordance with applicable building and fire codes. These standards and codes contain important information regarding protection of systems from freezing temperatures, corrosion, mechanical damage, etc.
 - These installation instructions are intended for an experienced, trained installer. The installer shall understand the use of this product and why it was specified for the particular application.
 - The installer shall understand common industry safety standards and potential consequences of improper product installation.
- Failure to follow installation requirements and local and national codes and standards could compromise system integrity or cause system failure, resulting in death or serious personal injury and property damage.

The Series 7C7 Air Maintenance/Compressor Assembly consists of air maintenance trim and a 1/6-Hp, 1/4-Hp, 1/2-Hp, 3/4-Hp, or 1-Hp air compressor. This assembly is designed to control system air pressure for:

- Series 768N FireLock NXT™ Dry System Check Valve
- Series 769N FireLock NXT™ Deluge System Check Valve (Pneumatic Systems)
- Series 769N FireLock NXT™ Preaction System Check Valve (Pneumatic Systems)
- Series 745 FireLock™ Fire-Pac Containing Any of the Above-Listed Configurations

A decrease in air pressure will close the pressure switch. When the pressure switch closes, the air compressor turns on to restore air pressure. When air pressure is restored, the air compressor turns off, and pressure in the compressor automatically bleeds off.

EXPLODED VIEW DRAWING – AIR MAINTENANCE TRIM OF THE SERIES 7C7

Bill of Materials

Item	Qty.	Description
1	1	Strainer (1/2-inch NPT Female)
2	1	Restrictor (1/2-inch NPT with 0.125 Dia. Orifice)
3	1	Ball Check Assembly (1/2-inch NPT)
4	1	Valve (1/2-inch NPT Female)
5	3	Ball Valve (1/2-inch NPT Female)
6	1	Air Pressure Switch (1/4-inch NPT Female) Air Pressure Switch (1/4-inch NPT Male)
7	3	Straight Tee (1/2-inch NPT Female)
8	5	Straight Elbow (1/2 NPT Female)
9	2	Union (1/2-inch NPT Female)
10	1	Hex Head Bushing (1/2-inch NPT Male X 1/4-inch NPT Female)
11	1	Nipple (1/4-inch NPT X Close)
12	5	Nipple (1/2-inch NPT X Close)
13	2	Nipple (1/2-inch NPT X 1 1/2 inch)
14	5	Nipple (1/2-inch NPT X 2 1/2 inch)
15	1	Nipple (1/2-inch NPT X 3 inch)
16	1	Nipple (1/2-inch NPT X 4 inch)
17	1	Identification Tag

NOTE: Pipe Nipple (Item 11) is not required if the male NPT connection is on the pressure switch (Item 6).

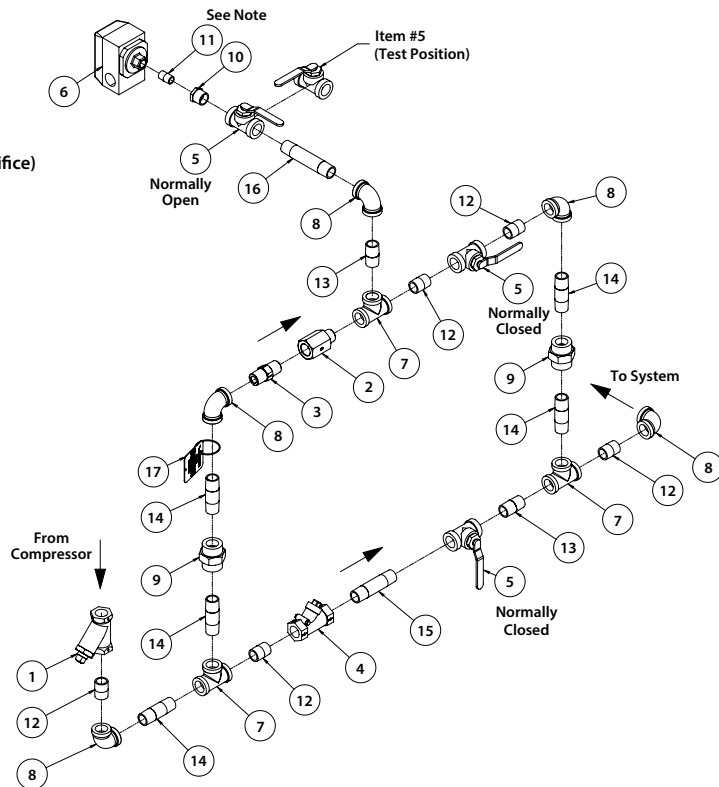

Exaggerated for Clarity

AIR SUPPLY REQUIREMENTS

NOTICE

- VICTAULIC RECOMMENDS ONLY ONE SYSTEM VALVE PER SERIES 7C7 AIR COMPRESSOR ASSEMBLY.

The required air pressure for FireLock Series 768N, 769N, and 764 system valves is 13psi/90kPa/0.9Bar minimum, regardless of the system supply water pressure. Normal air pressure shall not exceed 20psi/138kPa/1.4Bar. Victaulic presets the Series 7C7 Air Maintenance/Compressor Assembly to the recommended air pressure of 13psi/90kPa/0.9Bar as the “on” or “low” pressure setting for the compressor and 18psi/124kPa/1.2Bar as the “off” or “high” pressure setting. Failure to maintain air pressure within the 13psi/90kPa/0.9Bar to 18psi/124kPa/1.2Bar range may delay system operation response time.

The Series 7C7 Air Maintenance/Compressor Assembly SHALL NOT be used on a system valve installed with a Series 746 or 746-LPA Dry Accelerator.

The engineer/system designer is responsible for sizing the compressor so that the entire system is charged to the required air pressure within local code and standard guidelines (typically 30 minutes). DO NOT oversize the compressor to provide more airflow. An oversized compressor will slow down or possibly prevent valve operation.

EXPLODED VIEW DRAWINGS – SERIES 7C7 AIR MAINTENANCE COMPRESSOR ASSEMBLIES

1/6 HP OR 1/4 HP

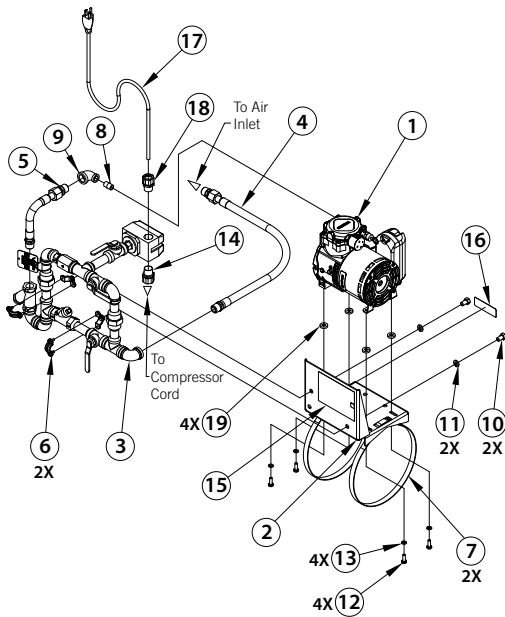

Item	Qty.	Description
1	1	Compressor
2	1	Mounting Bracket
3	1	Air Maintenance Trim with Pressure Switch
4	1	Trim Hose (26-inch-660-mm Length)
5	1	Trim Hose (11-inch Length)
6	2	Pipe Hangers
7	2	Hose Clamps
8	1	Pipe Nipple
9	1	Reducing Elbow
10	2	Bolts
11	2	Spring Lock Washers
12	4	Screws
13	4	Washers
14	1	Cord Connector
15	1	Safety/Information Label
16	1	Identification Label
17	1	14 AWG Ground Cord with Plug (CSA Only)
18	1	Connector (CSA Only)
19*	4	Memory Stop Washers

* Not required for the 3/4- or 1-Hp assemblies

1/2 HP

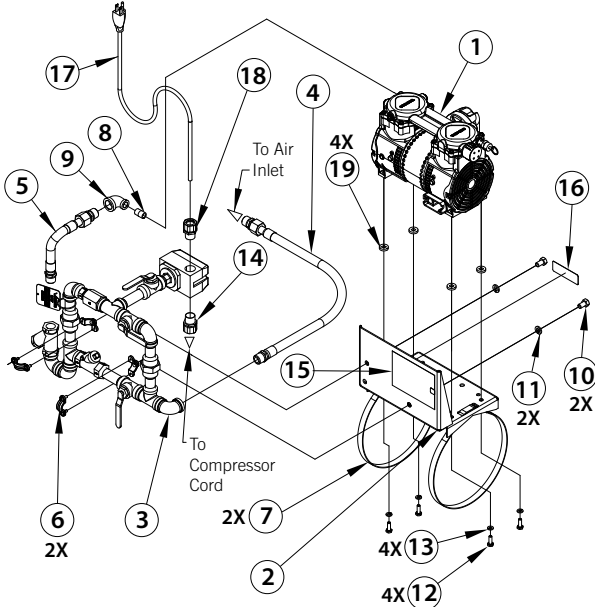

3/4 HP OR 1 HP

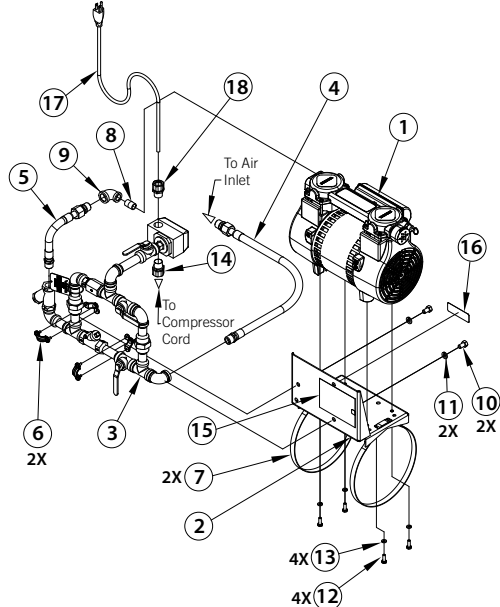

INSTALLATION OF THE SERIES 7C7 AIR MAINTENANCE/COMPRESSOR ASSEMBLY

NOTICE

- Two people are required to install the Series 7C7 properly and safely.
- Verify that the Series 7C7 is mounted in the correct orientation. Due to the swing check valve in the air maintenance trim, the compressor can be mounted vertically or horizontally.

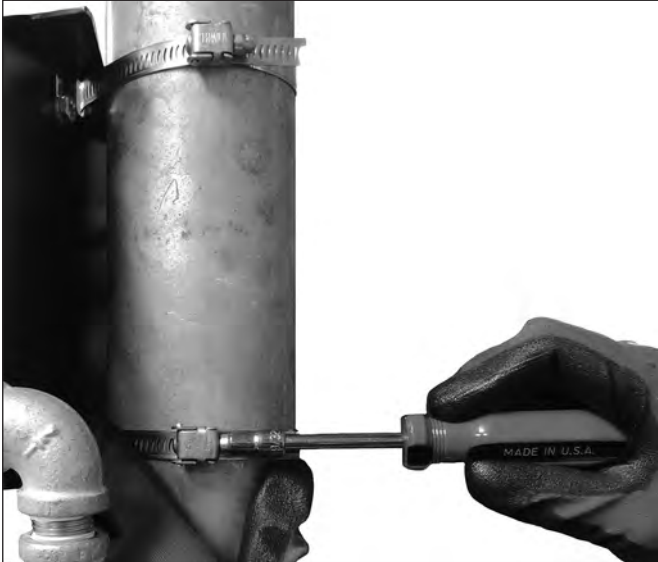

1. Mount the Series 7C7 Air Maintenance/Compressor Assembly on the riser with the hose clamps provided. When mounting the assembly on the riser, take into account the 26-inch/660-mm length of trim hose that will be installed from the elbow in the air maintenance trim into the air manifold in the actuator trim. Verify that the hardware is tightened completely.



2. Install the fitting from the 26-inch/660-mm length of trim hose into the air manifold in the actuator trim, as shown above.

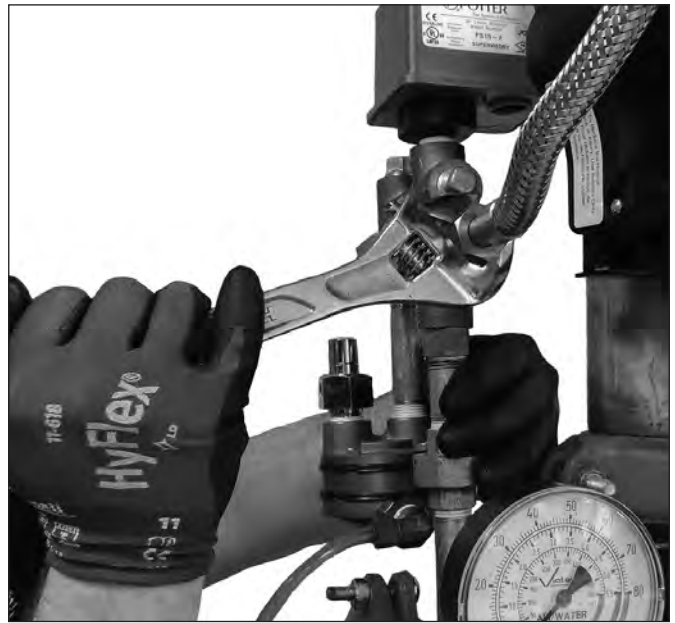

3. Connect the 26-inch/660-mm length of trim hose to the fitting in the air manifold, as indicated in the trim drawings. **NOTE:** Verify that the rubber washer is captured in the hose nut to prevent air leakage.

FAST-FILL BALL VALVE, SLOW-FILL BALL VALVE, AND PRESSURE SWITCH ISOLATION BALL VALVE INFORMATION

The following information describes the function of the fast-fill ball valve, the slow-fill ball valve, and the pressure switch isolation ball valve of the air maintenance trim. Always refer to the installation, maintenance, and testing manual for the system valve for complete setup information.

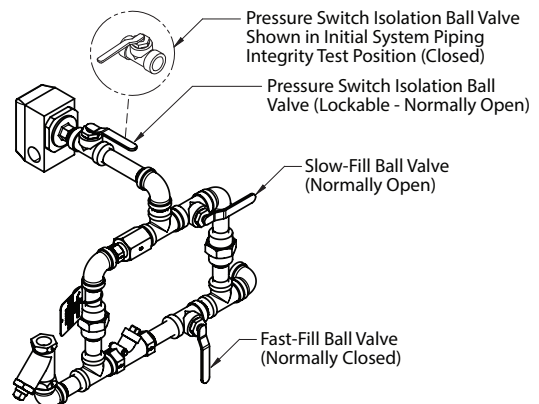

1. Open the slow-fill ball valve and fast-fill ball valve to charge the system. **NOTE:** The slow-fill ball valve's normal operating position is "open." Failure to leave the slow-fill ball valve open may allow system pressure to drop, resulting in valve operation in the event of a system leak.
2. Verify that the pressure switch isolation ball valve is open.
3. When system air pressure is established, close the fast-fill ball valve. The fast-fill ball valve's normal operating position is "closed."

SYSTEM PIPING INTEGRITY TEST

1. To perform the one-time initial system piping integrity test (per NFPA requirements), close the pressure switch isolation ball valve to allow the compressor to charge the system pressure above the cut-out pressure. Upon completion of the test, open the pressure switch isolation ball valve. Manually bleed the system pressure down to 18 psi/1.2 Bar by opening the system main drain valve. Lock the pressure switch isolation ball valve in the "open" position.

Series 7C7 Air Maintenance/Compressor Assembly

ELECTRICAL CONNECTIONS



⚠ DANGER

- Only qualified electricians shall connect incoming power to the Series 7C7 Air Maintenance/Compressor Assembly.
- Disconnect and lock-out the electrical supply before attempting to perform any connections.
- To reduce the risk of electric shock, check the electrical source for proper grounding.

Failure to follow these instructions could result in death or serious personal injury.

Only qualified electricians shall connect incoming power to the Series 7C7 Air Maintenance/Compressor Assembly. All wiring shall be completed in accordance with requirements of the local authority having jurisdiction and any applicable electrical codes.

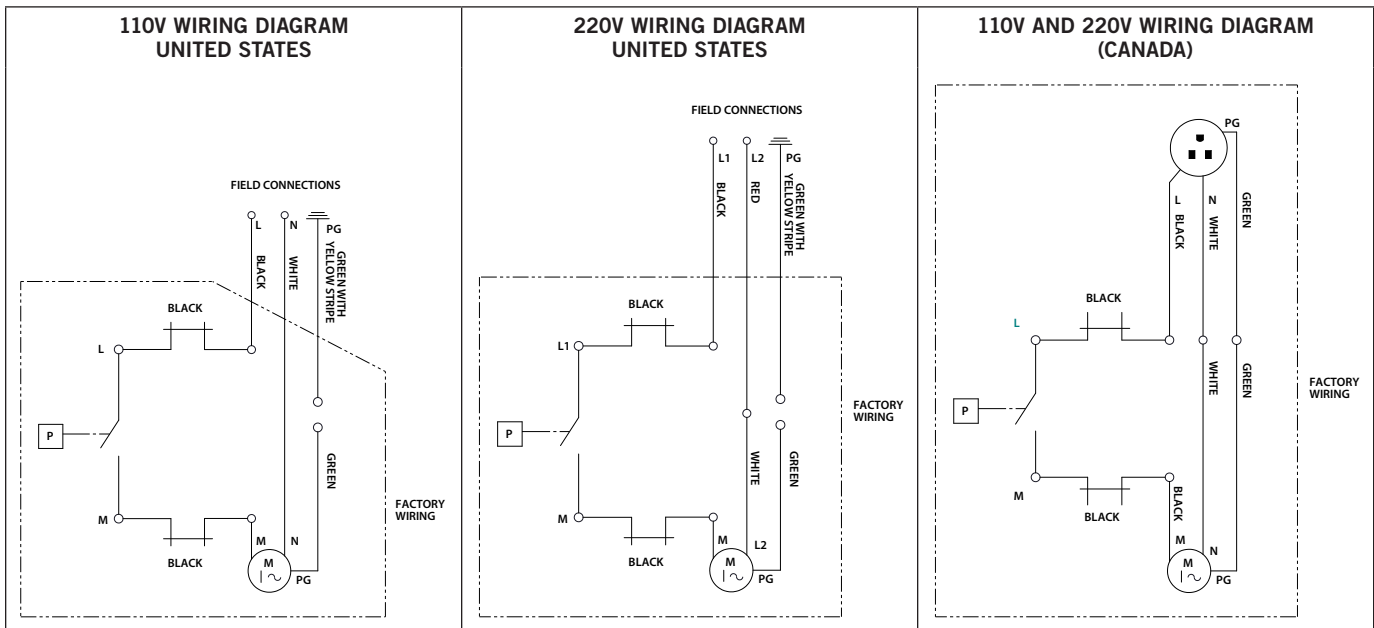
The pressure switch is factory set for typical system air pressures and DOES NOT require adjustment. **NOTE:** Any adjustment made may adversely affect operation and increase the cut-off time. Higher air pressure may slow down the system response time.



TROUBLESHOOTING

PROBLEM	POSSIBLE CAUSE	SOLUTION
Valve operates without sprinkler activation	Loss of air pressure in the system or trim Pressure switch is set too low, or the compressor is not operating properly	Check for any leaks in the system and trim. Confirm that the air maintenance trim is operating properly. Consider installing a low-air supervisory switch. Increase the "ON" setting of the pressure switch. Verify that the air compressor is operating properly.
Compressor short cycles/chatters	Manual pull station has operated Pressure switch is out of adjustment Slow-fill and fast-fill ball valves were closed at the same time, creating back pressure at the compressor	Close the manual pull station and reset the fire protection system by referencing the applicable installation, maintenance, and testing manual for the specific valve. Verify pressure gauge accuracy. Contact Victaulic for additional assistance. Open the slow-fill ball valve and wait for pressure to bleed down from the compressor.

For complete contact information, visit victaulic.com

