

FLEXIBLE GAS PIPING DESIGN GUIDE and INSTALLATION INSTRUCTIONS

December 2016



COMMERCIAL



INDUSTRIAL



RESIDENTIAL

TracPipe® CounterStrike®
Flexible Gas Piping by OmegaFlex®

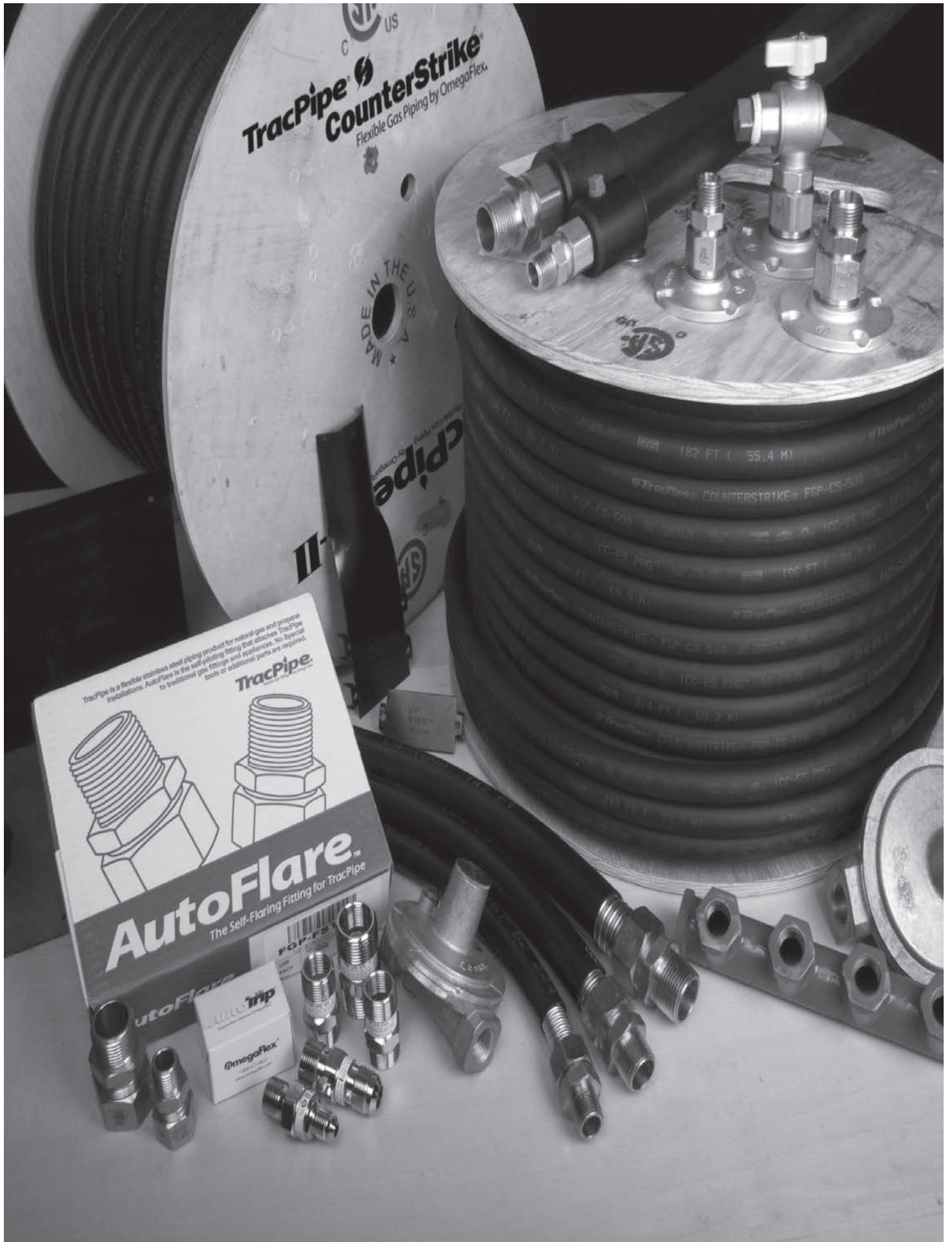

TracPipe CounterStrike
Flexible Gas Piping by OmegaFlex

MADE IN THE U.S.A.

TracPipe
OmegaFlex

TracPipe is a flexible stainless steel piping product for natural gas and propane installations. AutoFlare is the self-flaring fitting that attaches TracPipe to traditional gas fittings and appliances. No special tools or additional parts are required.

TracPipe



AutoFlare
The Self-Flaring Fitting for TracPipe

AutoFlare
OmegaFlex



TABLE OF CONTENTS

Chapter 1	Introduction	
1.0	User Warnings	3
1.1	Listing of applicable codes and standards	4
	TracPipe® CounterStrike® Specification Data Sheet	5
Chapter 2	Description of System and Components	
2.0	Tubing	6
	Fittings	6
	Accessories	6
	Manifolds	6
	Pressure Regulators	6
	Protection Devices	6
	Shut-off Valves	7
2.1	Material Use and Limitations	7
2.2	System Components	9
	TracPipe® CounterStrike® Flexible Gas Piping	9
	AutoFlare Fittings	10
	TracPipe® CounterStrike® Accessories	11
Chapter 3	System Configurations and Sizing	
3.1	System Configurations	13
3.1.1	Low-Pressure Systems-Series and Parallel	13
3.1.2	Dual Pressure Systems	13
3.1.3	System Design	14
3.1.4	System Pressure Choices	14
3.2	Sizing Methods and Examples	15
3.2.1	Use of Sizing Tables	15
3.2.2	Sizing Examples-Branch Length Method	15
	Low-Pressure Systems	15
	Elevated Pressure Systems	17
	Medium Pressure Systems	18
3.2.3	Sizing Hybrid Systems-Black Iron and TracPipe® CounterStrike® Combination	19
3.2.4	Alternate Sizing Method (Sum of Pressure Loss Calculations)	21
Chapter 4	Installation Practices	
4.1	General Installation Practices	25
	Debris Protection	25
	Minimum Bend Radius	25
	Support- Vertical Runs/ Horizontal Runs	26
4.2	Fitting Assembly	27
	Tubing Cutting/End Preparation	27
4.2.1	Assembly Procedure - AutoFlare®	27
	Minimum Tightening Torque - AutoFlare®	27
4.2.2	Assembly Procedure - AutoSnap®	29
	Minimum Tightening Torque - AutoSnap®	30
	Disassembly Procedure - AutoSnap®	30
	Trouble Shooting Fitting Connections	31
	Reassembly Procedure	31
4.3	Routing of Tubing	31
	Clearance Holes and Notching	32
4.3.1	Concealed Locations for Fittings-General Provisions	32
4.3.2	Outdoor Installation Issues	33
4.4	Protection	34
4.4.1	Striker Plate Requirements	34
	Spiral Metal Hose Requirements	35
4.4.2	Through Wall Penetrations	36
4.5	Meter Connections	37
	Termination Mounts/Meter Mounts	37
	Direct Connection	37
4.6	Appliance Connections	38
	Termination Fittings with Appliance Connectors	38
	Fixed Appliance Connections	38
4.6.1	Recessed Wall Box	39
4.6.2	Pad Mounted Equipment, Roof Top Equipment	41
4.6.3	Outdoor Appliances Barbeque Grills and Gas Light Connections	42
4.6.4	Fireplace Installations	43
4.7	Manifold and Regulator Station	44
	Allowable Locations	44
4.8	Pressure Regulators and Elevated Pressure Systems	45
	Installation Requirements	45
	Vent Limiter Option	45
	Vent Line and Sizing Requirements	45
4.8.1	Adjustments	45
4.8.2	Regulator Supply Pressure and Capacities Drop For Single and Multiple Appliances	46

4.8.3	Over Pressure Protection	47
4.9	Underground Installations	48
4.9.1	Guidelines for Underground Installations	48
4.9.2	TracPipe® PS-II	51
4.9.3	TracPipe PS-II Fitting Attachment	52
4.10	Electrical Bonding/Grounding	54
4.10.1	TracPipe® CounterStrike® Bonding Instruction	54
4.10.2	When Bonding is Required	54
Chapter 5	Inspection, Repair and Replacement	
5.1	Minimum Inspection Requirements (Checklist)	56
5.2	Repair/ of Damaged Tubing	57
5.3	Repair of Damaged Jacket	57
Chapter 6	Pressure/Leakage Testing	
6.0	Pressure Test Procedure	58
6.1	Pressure Test for Elevated Pressure Systems	58
6.1.1	Appliance Connection Leakage Check Procedure	59
6.1.2	Regulator Performance-Optional Testing	59
Chapter 7	Capacity Tables	
7.0	Sizing Tables	60
	Table N-1 Low Pressure (Standard)	61
	Table N-2A Low Pressure (Canada & USA 1 inch Drop)	61
	Table N-2B Low Pressure (Canada & USA 1.5 inch Drop)	62
	Table N-2C Low Pressure (Canada & USA 2.0 inch Drop)	62
	Table N-2D Low Pressure (Canada & USA 2.5 inch Drop)	63
	Table N-3 Regulator Outlet (8 inches W.C.)	63
	Table N-3A 3P Regulator Outlet (11 inches W.C.)	64
	Table N-4 Medium Pressure	64
	Table N-5 Elevated Pressure 2 PSI	65
	Table N-5A Elevated Pressure 2 PSI	65
	Table N-6 Elevated Pressure 5 PSI	66
	Table N-7 Elevated Pressure 10 PSI	66
	Table N-8 Elevated Pressure 25 PSI	67
	Table P-1 Propane Low Pressure (Standard)	68
	Table P-1A Propane Low Pressure	68
	Table P-1B Propane	69
	Table P-2 Propane Medium Pressure	69
	Table P-3 Propane Elevated Pressure 2 PSI	70
	Table P-4 Propane Elevated Pressure 5 PSI	70
	Table P-5 Propane Elevated Pressure 10 PSI	71
	Table P-6 Propane Elevated Pressure 25 PSI	71
7.1	Pressure Drop per Foot Tables for TracPipe® CounterStrike® (Natural Gas)	72
	Table PD-1A Pressure Drop per Foot for TracPipe® CounterStrike® (Natural Gas)	73
	Table PD-2A Pressure Drop per Foot for Black Iron (Natural Gas)	76
7.2	Sizing Table For Steel Pipe	80
	Table SP-1 Maximum Capacity of Pipe in Cubic Feet of Gas per Hour	81
Chapter 8	Definition of Terminology	
	Definitions	82
Appendix A	UL Classification	84
Appendix B	Manufactured Housing Guidelines	87
Appendix C	92
C1.1	AutoTrip® Low Pressure Excess Flow Valves for Natural Gas and Propane Service	92
C1.2	AutoTrip® LFD Series Excess Flow Valves for Meter and Branch Line/Manifold Applications	93
C1.2.1	Application, and Selection of AutoTrip® LFD Series Excess Flow Valves	94
C1.2.2	Gas Piping System Sizing with LFD Series Excess Flow Valves	95
C1.2.3	Methods of Sizing	95
C1.2.4	Sizing Instructions For AutoTrip® LFD Series EFVs Used With ConunterStrike® CSST Systems	95
C1.2.5	Sizing Instructions For AutoTrip® LFD Series EFVs Used With Low Pressure Steel Pipe Systems	96
C1.2.6	LFD Installation Instructions	96
C1.3	AutoTrip® AFD Series Excess Flow Valves for Appliance Connector Inlet Applications	97
C1.3.1	Application and Selection of AutoTrip® AFD Series Excess Flow Valves	98
C1.3.2	AFD Installation Instructions	99
	Table C.2 AutoTrip® AFD Series Appliance Connector Inlet Excess Flow Valves	99
C1.4	GasBreaker® Excess Flow Valves	100
AutoTrip® “LFD” Series Capacity Charts	101
	TABLE N-1AT AutoTrip® TracPipe® CounterStrike® (Low Pressure System)	101
	TABLE N-3AT AutoTrip® TracPipe® CounterStrike® (Dual Pressure System-8 in w.c. - Regulator outlet @ manifold)	101
	TABLE N-5AT TracPipe® CounterStrike® (2 PSI system)	102
	TABLE SP-1AT TracPipe® CounterStrike® - STEEL PIPE LOW PRESSURE	102
	TABLE 3.3 PROPANE— TracPipe® CounterStrike® AutoTrip® LFD Series Excess Flow Valves	103
	TABLE P-1AT AutoTrip® (Propane Low Pressure System 11 in w.c.) TracPipe® CounterStrike®	103
	TABLE C.4 TracPipe® CounterStrike® AutoTrip® - GasBreaker Equivalency Chart	104
	FIGURE C-3 Pressure Drop across TracPipe® CounterStrike® AutoTrip® LFD Series EFV at given Flow Rates	105

CHAPTER 1 INTRODUCTION



SECTION 1.0 — USER WARNINGS

Each installer must meet applicable qualifications in accordance with state and/or local requirements as established by the administrative authority which enforces the plumbing or mechanical codes where gas piping is installed. **The TracPipe® CounterStrike® CSST (corrugated stainless steel tubing) flexible gas piping material must only be installed by a qualified person who has been successfully trained through the The TracPipe® CounterStrike® gas piping installation program.**

This guide is updated periodically. Installers must use the most current version of the guide. Copies of updated guides are available for free at locations where **The TracPipe® CounterStrike®** is sold or online at www.tracpipe.com.

The guide must be used in conjunction with state and local building codes. Local codes will take precedence in the event of a conflict between this guide and the local code. In the absence of local codes, installation must be in accordance with the current edition of National Fuel Gas Code, ANSI Z223.1/NFPA 54, the National Standard of Canada, Natural Gas and Propane Installation Code, CSA B149.1, the Uniform Plumbing Code, the International Fuel Gas Code, the Federal Manufactured Home Construction and Safety Standards, ICC/ANSI 2.0 or the Standard on Manufactured Housing, NFPA 501, as applicable.

The jacket on the **The TracPipe® CounterStrike® CSST** shall not be removed, altered or modified in any fashion including full or partial painting or coating of the surface and the mounting of adhesively attached

plastic or paper labels without the express consent of **OmegaFlex®**.

Sound engineering principles and practices must be exercised for the proper design of fuel gas piping systems, in addition to compliance with local codes. The installation instructions and procedures contained in this Design Guide must be strictly followed. All installations must pass inspections by the local authority having jurisdiction prior to having the gas service turned on.

Only the components provided or specified by **OmegaFlex®** as part of the approved piping system are to be used in the installation.



The inter-connection of **TracPipe® CounterStrike®** tubing or **TracPipe® AutoFlare®** or **AutoSnap®** fittings directly with or on tubing or fittings from other CSST manufacturers is strictly prohibited and may result in a hazardous condition leading to serious bodily injury or property damage.

If this system is used or installed improperly, fire, explosion or asphyxiation may result. The installation instructions and applicable local codes must be strictly followed.



Omega Flex, Inc.
451 Creamery Way, Exton, PA 19341-2509
610-524-7272 Fax: 610-524-7282

1-800-671-8622 www.omegaflex.com

©Omega Flex Inc. 1997, 1998, 1999, 2001, 2002, 2003, 2004, 2005, 2007, 2009, 2011, 2014, 2015, 2016

OmegaFlex, TracPipe, AutoFlare, AutoTrip and CounterStrike are registered trademarks of Omega Flex, Inc.

SECTION 1.1 – APPLICABLE CODES AND STANDARDS

MODEL CODES:

NFPA-54 / ANSI Z223.1 - National Fuel Gas Code
NFPA-58 LP Gas Code
NFPA-70 National Electrical Code
NFPA-501 Manufactured Housing Code
ICC- International Fuel Gas Code
ICC- International Mechanical Code
ICC- International Residential Code
IAPMO- Uniform Plumbing Code
IAPMO- Uniform Mechanical Code

STANDARDS:

ANSI LC-1 / CSA 6.26 Standard for Fuel Gas Piping Systems Using Corrugated Stainless Steel Tubing
ICC- ES LC-1024 PMG Listing Criteria for Stainless Steel Tubing
IAPMO- IGC-201 The interim Guide Criteria for polyethylene Sleeved Corrugated Stainless Steel Tubing for use in Fuel Gas Piping Systems

LISTINGS:

CSA Certificate of Compliance #1082441
ICC- PMG 1046
ICC- PMG 1052
ICC- PMG 1058
IAPMO- ES 3682
IAPMO- ES 4665
IAPMO- ER 0227
UL- Through Penetration Firestop Systems / ASTM E84 Compliant

OTHER:

California Plumbing Code
California Mechanical Code
Massachusetts Product Approval
City of L.A. Product Approval RR 5495
City of L.A. Product Approval RR 5707

NOTICE: *TracPipe*® is the original yellow jacketed CSST gas piping system manufactured by *OmegaFlex*®. *TracPipe*® *CounterStrike*® is a next generation of CSST system which includes a revolutionary arc resistant black jacket.

NOTICE:

While every effort has been made to prepare this document in accordance with the most current model codes in effect at its printing, *OmegaFlex*® cannot guarantee that the local administrative authority adopts or accepts the most recent edition of these codes. The installer must use the current edition of the *TracPipe*® *CounterStrike*® Design Guide and Installation Instructions. The installer is ultimately responsible to determine suitability and acceptance of any building component, including gas piping. *OmegaFlex*® assumes no responsibility for materials or labor for installations made without prior determination of local code authority acceptance.

TracPipe® CounterStrike®

SPECIFICATION DATA SHEET

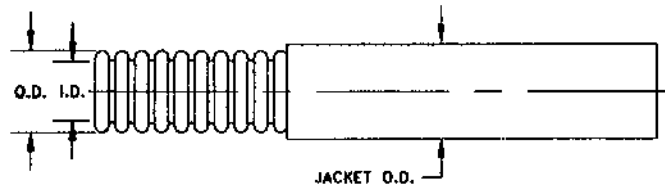

racPipe CounterStrike

Part No.	FGP-CS-375	FGP-CS-500	FGP-CS-750	FGP-CS-1000	FGP-CS-1250	FGP-CS-1500	FGP-CS-2000
Size (inch)	3/8"	1/2"	3/4"	1"	1-1/4"	1-1/2"	2"
EHD (AGA size)	15	19	25	31	39	46	62
Jacket O.D. (max.)	.700	.888	1.140	1.415	1.700	1.940	2.515
Inside Diameter (nom)	.440	.597	.820	1.040	1.290	1.525	2.060
Wall Thickness (in.)	.01	.01	.01	.01	.012	.012	.012

*EHD (Equivalent Hydraulic Diameter) A relative measure of Flow Capacity; This number is used to compare individual sizes between different manufacturers. The higher the EHD number the greater flow capacity of the piping.

STRAIGHT AUTOFLARE® / AUTOSNAP® FITTINGS

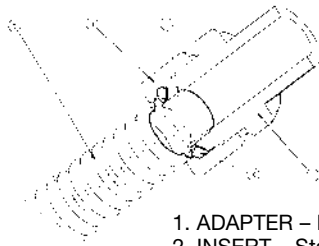

1. ADAPTER – Brass
2. INSERT – Stainless Steel
3. NUT – Brass
4. SPLIT-RINGS – Brass or Stainless Steel
5. FLEXIBLE PIPE – Stainless Steel

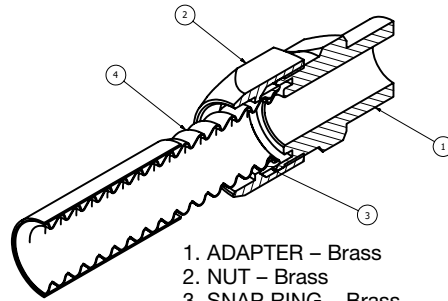

1. ADAPTER – Brass
2. NUT – Brass
3. SNAP RING – Brass
4. FLEXIBLE PIPE – Stainless Steel

AVAILABLE IN SIZES							
Tube size	3/8"	1/2"	3/4"	1"	1-1/4"	1-1/2"	2"
NPT Thread	1/2" or 3/8"	1/2" or 3/4"	3/4" or 1/2"	1" or 3/4"	1-1/4"	1-1/2"	2"

FLANGE MOUNT AUTOFLARE® / AUTOSNAP® FITTINGS

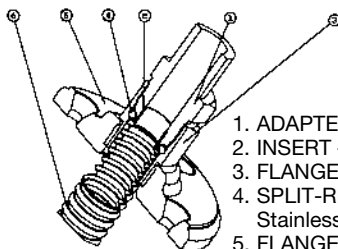

1. ADAPTER – Brass
2. INSERT – Stainless Steel
3. FLANGE NUT – Brass
4. SPLIT-RINGS – Brass or Stainless Steel
5. FLANGE – Brass
6. FLEXIBLE PIPE – Stainless Steel

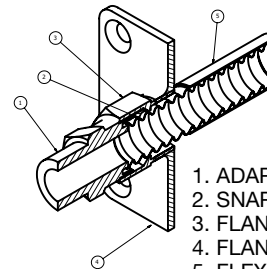

1. ADAPTER – Brass
2. SNAP RING – Brass
3. FLANGE NUT – Brass
4. FLANGE – Steel
5. FLEXIBLE PIPE – Stainless Steel

AVAILABLE IN SIZES					
Tube Size	3/8"	1/2"	3/4"	1"	1-1/4"
NPT Thread	1/2" or 3/8"	1/2"	3/4"	1"	1-1/4"

CONSULT FACTORY FOR OTHER TERMINATION METHODS

CHAPTER 2

DESCRIPTION of SYSTEM and COMPONENTS

SECTION 2.0 – *TracPipe*® *CounterStrike*® FLEXIBLE GAS PIPING MATERIAL DESCRIPTION

1. TUBING

The *TracPipe*® *CounterStrike*® fuel gas piping system consists of corrugated, flexible, semi-rigid, stainless steel tubing with brass mechanical attachment fittings terminating in NPT pipe threads for easy attachment to traditional black iron pipe systems and direct connections to gas appliances. Tubing is available in sizes 3/8 inch, 1/2 inch, 3/4 inch, 1 inch, 1-1/4 inch, 1-1/2 inch, and 2 inch.

The 300 series stainless steel tubing is jacketed with a non-metallic cover which provides ease of running through joists, studs, and other building components. The jacket is marked at intervals with the amount of tubing left on the reel, for quick measurement.



2. FITTINGS

Straight NPT pipe fittings are standard and are available in sizes shown above to fit all tubing. Additional fittings include termination mount and flange-mount straight and 90 degree elbow fittings for termination of gas lines near movable appliances; and meter termination accessories for support of *TracPipe*® *CounterStrike*® at utility meter sets on building exteriors and roof penetrations. Tee fittings are available for addition of branch lines into tubing runs; reducer tees are available in popular sizes and pipe outlet tees terminate in pipe threads on the outlet leg for size changes utilizing available black iron reducer fittings.

3. ACCESSORIES

Accessories are available for expansion of the flexible piping material and additions to existing fuel gas piping systems. These accessories include:

- A. Manifolds: Allows parallel installations with “home runs” to each appliance. 1/2 inch female NPT outlets and 3/4 inch and 1/2 inch female NPT inlets. Large size manifolds are also available for use with commercial size *TracPipe*® *CounterStrike*®.



- B. Pressure Regulators: Pounds to inches - for use in elevated pressure system installations (over 14 inches water column - one half PSI) to reduce pressure to standard low pressure for appliances.

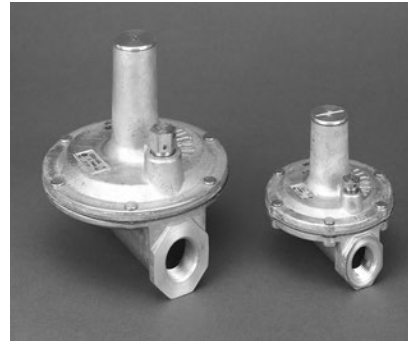

Regulators are available for use with natural and propane gas.

- C. Protection Devices: For use where flexible piping passes through studs, joists and other building materials and is restricted from moving to avoid nails, screws and other puncture threats.



There are five striker plate configurations made from stamped steel and specially hardened to resist penetration from screws and pneumatic nail guns. These are quarter-striker, half striker, three quarter striker, full-striker and 6 inch X 17 inch flat plate striker. Spiral wound galvanized steel “floppy” conduit is available for use as additional protection.

D. Shut-off Valves-for use in elevated pressure installations:

2 PSI up to 5 PSI. (Standard gas-cocks should be used at appliance stub outs and other low pressure



areas of the piping system.) Brass lever-handle ball valves supplied by **OmegaFlex®** are rated for 5 PSI use and are available in 1/2 inch and 3/4 inch sizes.

NOTICE: For additional specifications see submittal sheets on the website at www.tracpipe.com.

SECTION 2.1 – MATERIAL USE AND LIMITATIONS

This Design and Installation Guide has been written in accordance with the most current edition of ANSI LC 1/ CSA 6.26, FUEL GAS PIPING SYSTEMS USING CORRUGATED STAINLESS STEEL TUBING (CSST).

This Design Guide is intended to aid the professional gas pipe installer in the design, installation and testing of flexible fuel gas piping systems for residential, commercial and industrial buildings. It is not possible for this guide to anticipate every variation in construction style, building configuration, appliance requirement, or local restriction. This document will not cover every application. The user should either exercise his own engineering judgment on system design and installation, or seek technical input from other qualified sources. Additional information pertaining to gas

piping systems is available from your local gas utility or propane supplier. Some of the special usage features of **TracPipe® CounterStrike®** flexible gas piping are outlined below:

1. Flexible gas piping is used to provide safe, efficient, timely installation of fuel gas piping within buildings, residential, commercial, and industrial, or for outdoor connections to appliances that are attached or in close proximity to the building.
2. Flexible gas piping can be routed in most locations where traditional gas piping materials are installed: inside hollow wall cavities, along or through floor joists in basements, on top of the joists in attics, on roof tops or along soffits or in chases outside of buildings. **TracPipe® CounterStrike®** gas piping has been tested and is listed by CSA International for both outdoor and indoor use.
3. **TracPipe® CounterStrike®** is listed by CSA International for fuel gas use in the USA and Canada for pressures up to 25 PSI. For local gas utility approved use only, **TracPipe® CounterStrike®** has been tested for use up to 125 PSI for sizes 3/8 inch up to 1-1/4 inch.
4. In North America, the most common pressure for Natural Gas is 6-7 inches water column, standard low pressure. Elevated pressures of either 2 PSI or one half PSI are also available from utilities in most areas for new residential construction. 5 PSI systems are commonly installed in commercial or industrial buildings. Elevated pressures allow the use of smaller diameter piping, while providing for increased loads and longer length runs.
5. Flexible gas piping can be used for natural gas and propane (Liquefied petroleum gas) and other fuel gases recognized in NFPA 54 National Fuel Gas Code.

6. **TracPipe® CounterStrike®** with the black polyethylene jacket has been tested by Underwriters Laboratory to ASTM E84 (UL723) Surface Burning Characteristics with flame spread and smoke density ratings meeting the requirements of ANSI/CSA LC-1 for use in air ducts and plenums. It is mandatory, however, to follow fire and building code requirements in all installations.
7. For underground or under slab burial the flexible gas piping run must be encased in a sleeve of polyethylene, or other approved water resistant material. See Section 4.9, **Underground Installations**. Sleeved runs under concrete slabs beneath buildings must be installed as required by local codes. Most codes require venting of the sleeves under buildings. This can be accomplished using pre-sleeved **TracPipe® PS-II** with available accessories.
8. Flexible gas piping can be used in conjunction with both steel pipe (black iron or galvanized) and copper tubing in either new construction or renovation and replacement piping installations. All **TracPipe® CounterStrike®** fittings terminate in standard NPT male or female pipe threads to interface with appliances, valves, unions and couplings.
9. For retrofit installations, **TracPipe® CounterStrike®** can be snaked through hollow wall cavities without major restoration as is typical when running rigid pipe through existing construction. The replacement or addition of gas appliances, fireplaces, and gas logs is greatly facilitated with flexible piping on reels requiring no special tooling or oily threading equipment.
10. **TracPipe® CounterStrike®** gas piping can be run directly to the shut off valves of fixed appliances. For moveable appliances such as ranges or dryers, the use of an approved flexible appliance con-



necter is required.

TracPipe® CounterStrike® cannot be substituted as a connector for this use when the appliance is free to move for cleaning, etc.

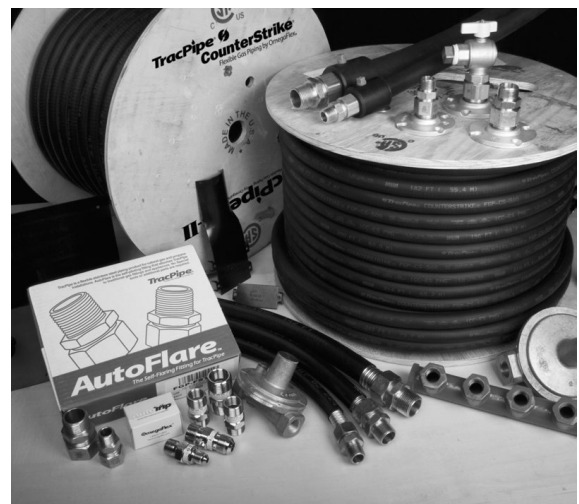
11. **TracPipe® AutoFlare®** and **AutoSnap®** fittings have been tested by CSA International and are listed for use in concealed locations as defined in NFPA 54 National Fuel Gas Code, The Uniform Plumbing Code, and The International Fuel Gas Code.
12. **TracPipe® CounterStrike®** has been evaluated for resistance to damage imposed by shifting appliances and/or by damage to structural framing caused by earthquakes.



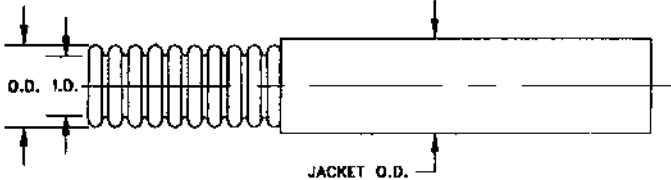



SECTION 2.2 – SYSTEM COMPONENTS
TracPipe® CounterStrike® Flexible Gas Piping

Component	Material	Description/Dimensions																																								
<p>TracPipe® CounterStrike® Flexible Gas Piping</p>	<p>Corrugated Stainless Steel (300 Series) with Polyethylene Jacket</p>	<div style="text-align: center;">  </div> <table border="1" data-bbox="625 604 1461 808"> <thead> <tr> <th>part no.</th> <th>FGP-CS-375</th> <th>FGP-CS-500</th> <th>FGP-CS-750</th> <th>FGP-CS-1000</th> <th>FGP-CS-1250</th> <th>FGP-CS-1500</th> <th>FGP-CS-2000</th> </tr> </thead> <tbody> <tr> <td>Size (inch)</td> <td>3/8"</td> <td>1/2"</td> <td>3/4"</td> <td>1"</td> <td>1-1/4"</td> <td>1-1/2"</td> <td>2"</td> </tr> <tr> <td>EHD (AGA size)</td> <td>15</td> <td>19</td> <td>25</td> <td>31</td> <td>39</td> <td>46</td> <td>62</td> </tr> <tr> <td>Jacket O.D. (max.)</td> <td>.700</td> <td>.888</td> <td>1.140</td> <td>1.415</td> <td>1.700</td> <td>1.940</td> <td>2.515</td> </tr> <tr> <td>Inside Dia. (nom)</td> <td>.440</td> <td>.597</td> <td>.820</td> <td>1.040</td> <td>1.290</td> <td>1.525</td> <td>2.060</td> </tr> </tbody> </table> <p>*EHD (Equivalent Hydraulic Diameter) A relative measure of Flow Capacity; This number is used to compare individual sizes between different manufacturers. The higher the EHD number the greater flow capacity of the piping.</p>	part no.	FGP-CS-375	FGP-CS-500	FGP-CS-750	FGP-CS-1000	FGP-CS-1250	FGP-CS-1500	FGP-CS-2000	Size (inch)	3/8"	1/2"	3/4"	1"	1-1/4"	1-1/2"	2"	EHD (AGA size)	15	19	25	31	39	46	62	Jacket O.D. (max.)	.700	.888	1.140	1.415	1.700	1.940	2.515	Inside Dia. (nom)	.440	.597	.820	1.040	1.290	1.525	2.060
part no.	FGP-CS-375	FGP-CS-500	FGP-CS-750	FGP-CS-1000	FGP-CS-1250	FGP-CS-1500	FGP-CS-2000																																			
Size (inch)	3/8"	1/2"	3/4"	1"	1-1/4"	1-1/2"	2"																																			
EHD (AGA size)	15	19	25	31	39	46	62																																			
Jacket O.D. (max.)	.700	.888	1.140	1.415	1.700	1.940	2.515																																			
Inside Dia. (nom)	.440	.597	.820	1.040	1.290	1.525	2.060																																			
<p>TracPipe® CounterStrike® on Reels</p>	<p>Plywood Reels for packaging</p>	<div style="text-align: center;">  </div> <p style="text-align: center;"><i>Note: other reel lengths available upon request.</i></p> <table border="1" data-bbox="669 1432 1451 1915"> <thead> <tr> <th>Pipe Size</th> <th>Standard Reel Length</th> <th>Maximim Reel Weight</th> </tr> </thead> <tbody> <tr> <td>3/8 inch</td> <td>250 feet 100 feet</td> <td>37 pounds</td> </tr> <tr> <td>1/2 inch</td> <td>500 feet 250 feet 100 feet 50 feet</td> <td>98 pounds</td> </tr> <tr> <td>3/4 inch</td> <td>250 feet 100 feet 50 feet</td> <td>70 pounds</td> </tr> <tr> <td>1 inch</td> <td>180 feet 100 feet 50 feet</td> <td>70 pounds</td> </tr> <tr> <td>1-1/4 inch</td> <td>250 feet 150 feet</td> <td>129 pounds</td> </tr> <tr> <td>1-1/2 inch</td> <td>250 feet 150 feet</td> <td>182 pounds</td> </tr> <tr> <td>2 inch</td> <td>150 feet</td> <td>137 pounds</td> </tr> </tbody> </table>	Pipe Size	Standard Reel Length	Maximim Reel Weight	3/8 inch	250 feet 100 feet	37 pounds	1/2 inch	500 feet 250 feet 100 feet 50 feet	98 pounds	3/4 inch	250 feet 100 feet 50 feet	70 pounds	1 inch	180 feet 100 feet 50 feet	70 pounds	1-1/4 inch	250 feet 150 feet	129 pounds	1-1/2 inch	250 feet 150 feet	182 pounds	2 inch	150 feet	137 pounds																
Pipe Size	Standard Reel Length	Maximim Reel Weight																																								
3/8 inch	250 feet 100 feet	37 pounds																																								
1/2 inch	500 feet 250 feet 100 feet 50 feet	98 pounds																																								
3/4 inch	250 feet 100 feet 50 feet	70 pounds																																								
1 inch	180 feet 100 feet 50 feet	70 pounds																																								
1-1/4 inch	250 feet 150 feet	129 pounds																																								
1-1/2 inch	250 feet 150 feet	182 pounds																																								
2 inch	150 feet	137 pounds																																								

TracPipe® AutoFlare® / AutoSnap® Fittings

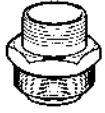
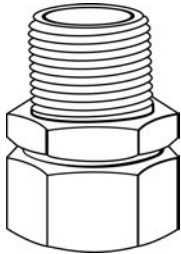
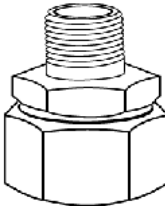
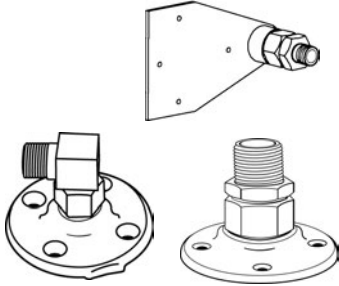
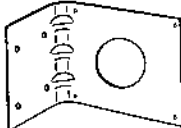
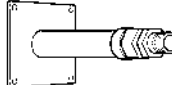
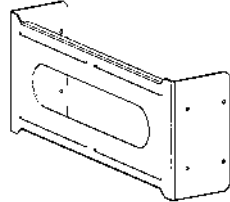
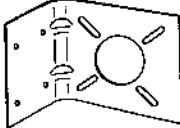
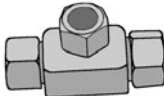
The fittings and accessories pictured on the following pages are representative of the range of products available from **CounterStrike®**. Refer to the latest **CounterStrike®** Price Sheet for a complete listing of part numbers.

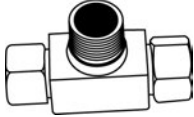
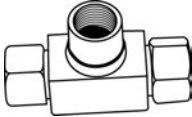
Component	Material	Description/Dimensions
TracPipe® PS-II Accessories		<p style="text-align: center;">PS-II</p> <div style="display: flex; justify-content: space-around; align-items: center;">     </div> <p style="text-align: center;"> Vent Coupling Nut Split Rings Adapter </p>
Straight Mechanical Fitting Reducer Fitting	Brass Fitting AutoSnap® AutoFlare® Insert	<div style="display: flex; justify-content: space-around; align-items: center;">   </div> <p style="text-align: right;"> Sizes: 3/8, 1/2, 3/4, 1, 1-1/4, 1-1/2 and 2 inch Note size 3/8 fitting has either 1/2" NPT or 3/8" NPT Thread </p>
Termination and Flange Mount Fittings—Straight and 90 Elbow	Brass Fitting AutoSnap® AutoFlare® Insert Brass Flange	<div style="display: flex; justify-content: space-around; align-items: center;">  </div> <p style="text-align: right;"> Sizes: 3/8, 1/2, 3/4, 1 inch and 1-1/4 inches Note size 3/8 fitting has either 1/2" NPT or 3/8" NPT Thread Elbow Sizes: 3/8 in. and 1/2 in. </p>
Meter Termination Fitting Stud Bracket	Brass Fitting AutoSnap® AutoFlare® Insert Galv. steel Mounting Bracket	<div style="display: flex; justify-content: space-around; align-items: center;">    </div>
Flange Mounting Bracket	Galvanized Steel	<div style="display: flex; justify-content: space-around; align-items: center;">  </div> <p style="text-align: right;"> One size fits all: Size 3/8 through 1-1/4 inches </p>
Tee Fitting & Coupling	Brass Tee Fitting & Coupling AutoSnap® AutoFlare® Insert	<div style="display: flex; justify-content: space-around; align-items: center;">     </div> <p style="text-align: center;"> Sizes: 3/8, 1/2, 3/4, 1, 1-1/4, 1-1/2, and 2 inch Reducer tees available for 1/2, 3/4, 1, 1-1/4, 1-1/2, and 2 inch sizes </p>

TracPipe® CounterStrike® Accessories

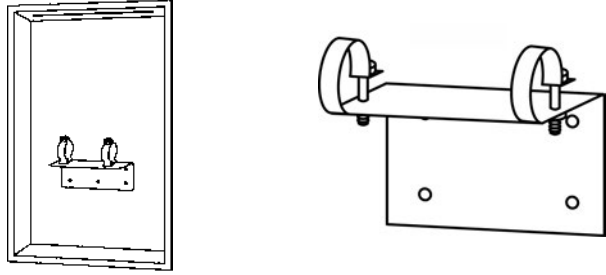
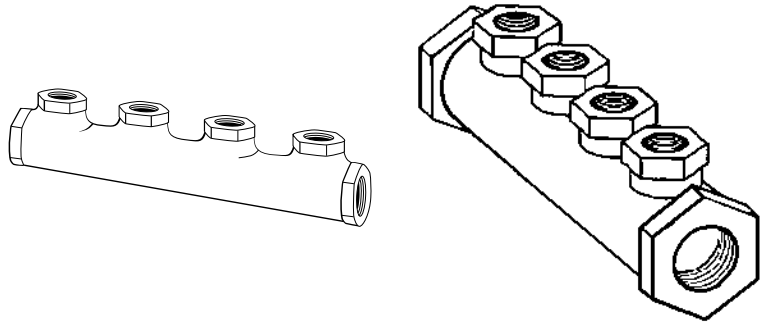
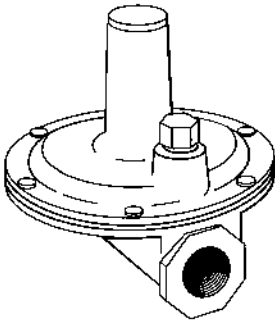
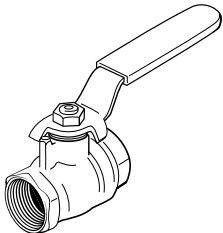
Component	Material	Description/Dimensions
<p>Load Center</p> <p>Manifold Bracket</p>	<p>Painted Steel</p> <p>Galvanized Steel</p>	
<p>Multi-Port Manifolds</p>	<p>Malleable Iron</p> <p>Poly Coated</p>	
<p>Pressure Regulators</p>	<p>Cast Housing Suitable for Outdoor Use</p>	 <p>Sizes: 1/2 inch & 3/4 inch & 1 inch Regulator includes approved vent limiting device for REG-3 (1/2 inch), REG-5A (3/4 inch) and REG-7L (1 inch).</p> <p>Note: Stainless steel high pressure tags are available for use where required by code</p>
<p>Shut Off Valves</p>	<p>Brass Housing with Stainless Steel Ball</p>	 <p>Sizes: 1/2 inch & 3/4 inch</p>

TracPipe® CounterStrike® Accessories

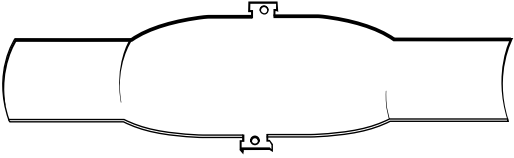
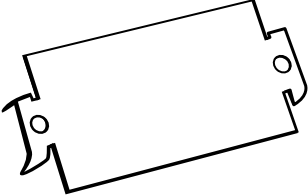
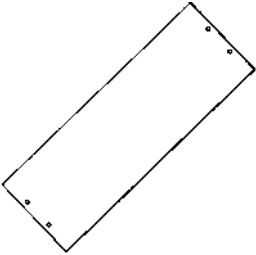
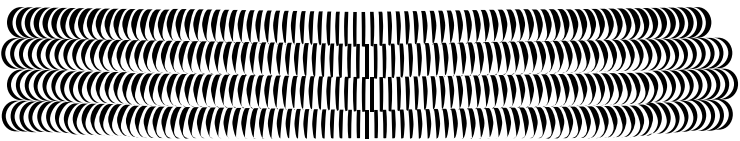
Component	Material	Description/Dimensions
Full Striker Plate	Carbon Steel Hardened	 <p>size: 3" x 12"</p>
Half Striker Plate & Three Quarter Striker Plate	Carbon Steel Hardened	 <p>size: 3" x 7" size: 3" x 8"</p>
Quarter Striker Plate	Carbon Steel Hardened	 <p>size: 3" x 2"</p>
6.5 inch x 17 inch Striker Plate	Carbon Steel Hardened	 <p>size: 6.5" x 17"</p>
Floppy Strip Wound Conduit	Type RW Galvanized Steel	 <p>sizes: Fits 3/8", 1/2", 3/4", 1", 1-1/4", 1-1/2" and 2" CounterStrike®</p>

CHAPTER 3

SYSTEM CONFIGURATIONS AND SIZING

SECTION 3.1 – SYSTEM CONFIGURATIONS

There are several piping system options available to the installer using **TracPipe® CounterStrike®** gas piping material. This flexibility of design is one of the major benefits of CSST.

3.1.1 – LOW PRESSURE SYSTEMS

1. SERIES: A series layout is the most common arrangement utilized for black iron pipe. This consists of a main run with tees branching off to each appliance.

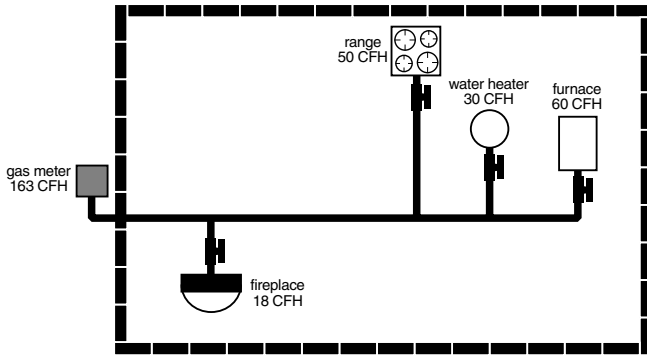

Series Layout

2. PARALLEL: A parallel system consists of a central distribution manifold with branch runs to the appliances. This is usually accomplished by providing a main supply line to a manifold and installing “home runs” to each appliance location. In the parallel system shown below the pressure is not elevated above 1/2 pound and no regulator is required.

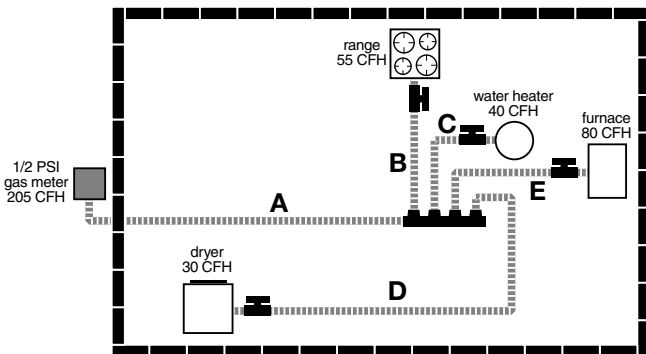

Parallel Layout

3.1.2 – DUAL PRESSURE SYSTEMS

Elevated pressure systems (2 PSI for residential and up to 5 PSI for commercial installations) are usually piped with one or more line gas pressure regulators (pounds-to-inches) followed by a manifold and runs to each of the appliances. It is possible that these runs to appliances may contain tees branching off to an additional appliance where gas loads permit.

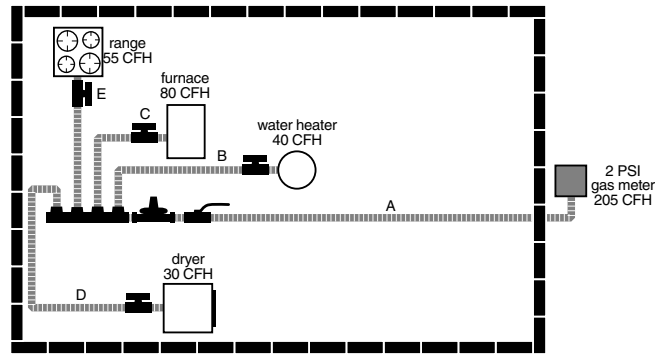

NOTICE:

HYBRID SYSTEMS – FLEXIBLE GAS PIPE and RIGID BLACK PIPE COMBINATIONS. In low or medium pressure systems, it is often advantageous to use both corrugated stainless steel tubing and rigid pipe in the same system. This is the case when a larger diameter main branch is required to provide for the total appliance load in a parallel system. **TracPipe® CounterStrike®** is certified for use in combination with black iron pipe and copper tube gas piping systems. For additional information on Hybrid Systems, see examples showing the method for sizing hybrid systems using both **TracPipe® CounterStrike®** and black iron pipe. These are included in the SIZING EXAMPLES section of this manual. Refer to Section 3.2C

SECTION 3.1.3 – SYSTEM DESIGN

1. Start by creating a sketch or layout of the gas piping system you are about to install. The information you will need is the location of each appliance, the point of delivery (location of utility meter or second stage LP regulator), appliance load demands, and possible pipe routing locations. The load demand data is usually available on the appliance manufacturer's nameplate, or can be provided by the builder.
2. Determine local piping restrictions prior to installing flexible gas piping. The major code bodies in North America have written Corrugated Stainless Steel Tubing into the latest revisions of their mechanical codes, but local and state adoption of these codes often lags behind.

Confirm that the local code authority has accepted the use of flexible gas piping. Your **TracPipe® CounterStrike®** distributor should be able to provide that information but confirmation by the installer should be made where there is any questions.

SECTION 3.1.4 – SYSTEM PRESSURE CHOICES

1. NATURAL GAS -Determine the delivery pressure provided by the Local Distribution Utility where the piping will be installed.
 - a. LOW PRESSURE-6 to 7 inches water column (equivalent to 4 ounces or 1/4 pound) is the standard pressure supplied by natural gas utilities in the USA and Canada.
 - b. MEDIUM PRESSURE-1/2 PSI (12 to 14 inches water column) is available from many natural gas utilities as an alternate pressure supply. The increase in pressure provides for reductions in pipe size and does not require a pressure regulator. Most natural gas appliances manufactured for use in

the US and Canada are designed to operate up to a maximum of 14 inches water column.

- c. ELEVATED PRESSURE-2 PSI is the highest natural gas pressure usually supplied within residential buildings in North America. This pressure always requires the installation of a pounds-to-inches line pressure regulator between the utility meter set and the appliances.
2. PROPANE (LP GAS) is typically supplied within residential buildings at 11 inches water column which is set at the second stage regulator mounted outside the building. Propane can also be utilized at medium pressure with the use of a 13-14 inch setting. For 2 PSI propane elevated pressure use, use a line gas pressure regulator that is set for 11 inches water column outlet pressure.

NOTICE: **TracPipe® CounterStrike®** has been tested by CSA International for a working pressure of 125 PSI for sizes 3/8 inch through 1-1/4 inch.

PRESSURE CONVERSION CHART

1/4 PSI	=	7" w.c.	=	4 oz.
1/2 PSI	=	14" w.c.	=	8 oz.
1 PSI	=	28" w.c.	=	16 oz.
2 PSI	=	56" w.c.	=	32 oz.

SECTION 3.2 SIZING METHODS and EXAMPLES

SECTION 3.2.1 – USE OF SIZING TABLES

This Chapter includes flexible gas piping sizing procedures for both low pressure and elevated pressure systems. Every piping system introduces pressure loss to the fluid flowing within. The amount of loss depends on the piping size and the gas flow, expressed in cubic feet per hour (and converted to BTU's). The object of the sizing exercise is to determine the smallest size piping which will introduce the allowed pressure loss or drop within the length of piping required. Sizing tables (capacity charts) provide the maximum flow capacity for a given length of run for each pipe size. A different sizing table is used for each system pressure and pressure drop combination.

1. The low pressure series system (standard arrangement) is sized in the same way as a conventional low pressure black iron pipe system using **TracPipe® CounterStrike®** sizing tables or tables found in National Fuel Gas Code NFPA 54. This method is known as the “Branch Length Method”. Pressure drop in a low pressure system is usually limited to 0.5 inch water column over the system.
2. Elevated pressure systems incorporate two operating pressures downstream of the utility meter set. The first pressure, set by the service regulator at the meter, is usually 2 PSI. This part of the system is sized separately and ends at the line pressure regulator.
3. For a 2 PSI system, the proper drop is usually 1 PSI for this part of the system; this allows for the approximate 3/4 PSI regulator drop downstream and provides the 1/4 PSI (6-7 inches w.c.) necessary for appliances. The regulator reduces the pressure from pounds to 8 inches water column. This part of the system is sized the same as a low pressure system, except that a special Table N-3 is used allowing 3 inches of water column drop. These lines

are typically sized for only one appliance load installed as a “home run” from the manifold.

SECTION 3.2.2 – SIZING EXAMPLES -BRANCH LENGTH METHOD

To size each of the following systems, determine the required size for each section and outlet. To size each section of the system, determine both the total gas load for all appliances and the maximum distance (longest length) in which a particular section delivers gas.

EXAMPLE 1: LOW PRESSURE SYSTEM SERIES ARRANGEMENT

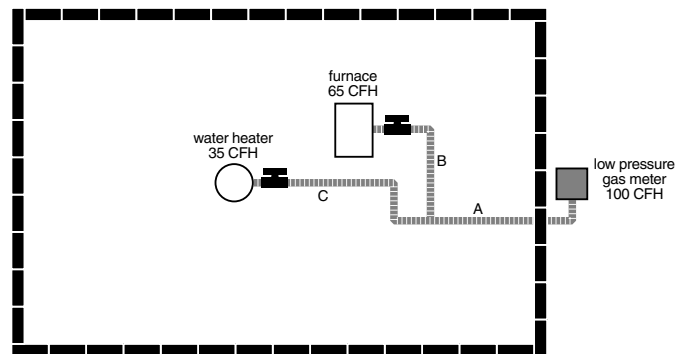
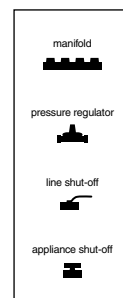

Figure: 3-1



LENGTH OF RUNS

A = 10 Feet
B = 10 Feet
C = 15 Feet

Supply pressure 6 inches w.c.
Allowable drop 0.5 inches w.c.

1. The system presented in Figure: 3-1 is typical of a single family installation in which there are a limited number of appliances located in one general area. The supply pressure is 6 inches water column and the allowable drop is 0.5 inch.

2. To size section A, determine the longest run from the meter that includes section A and the total gas load it must deliver:

- Meter to Furnace is 20 ft. (A+B).
- Meter to Water Heater is 25 ft. (A+C). This is the longest run.
- Determine the maximum load transported by Section A.
- Furnace plus water heater = 100 CFH (100,000 BTU).
- Select Table N-1 “Low Pressure 6 inches- 0.5 inch w.c. drop”.

- Using the longest run method, select the column showing the measured length, or the next longest length if the table does not give the exact length. Referring to table N-1 the column for 25 feet of piping shows that sizes 3/8 inch and 1/2 inch are too small and the next available size is 3/4 supplying 157 CFH.

- The correct size is 3/4”.

3. To size Section B, determine the length of run from the meter to the Furnace and the load delivered:

- Length is 20 ft (A+B) and load is 65 CFH (65,000 BTU).
- Table N-1 shows that size 1/2 inch supplies 70 CFH.
- The correct size is 1/2 inch.

4 To size Section C, determine the length of run from the meter to the Water Heater and the load delivered:

- Length is 25 ft (A+C) and load is 35 CFH (35,000 BTU).
- Table N-1 shows that size 1/2 inch is required, because size 3/8 inch only supplies 29 CFH (29,000 BTU).
- The correct size is 1/2 inch.

EXAMPLE 2: MEDIUM PRESSURE 12-14 INCHES W.C. (1/2 PSI)

1. The system shown in Figure: 3-2 is typical

of a single family installation with several appliances. The arrangement chosen is parallel. The MEDIUM PRESSURE SYSTEM (1/2 PSI) allows a higher pressure drop (6 inches water column) than is available with low pressure systems.

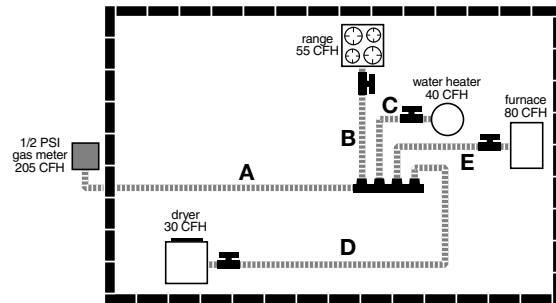
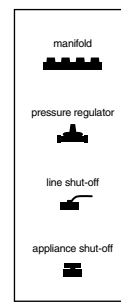

Figure: 3-2

LENGTH OF RUNS

- A = 10 Feet
- B = 20 Feet
- C = 10 Feet
- D = 40 Feet
- E = 10 Feet

Supply pressure 1/2 PSI (12 inch-14 inch w.c.) Allowable drop: 6 inch w.c.



2. To size SECTION A, determine the LONGEST RUN from the meter to the furthest appliance:

- Meter to dryer is 50 feet (10+40) A+D.
- Determine maximum load transported by section A.
- Dryer + range + water heater + furnace = 205 CFH (205,000 BTU).
- Select table N-4 “Medium Pressure 1/2 PSI with 6 inch drop”. Table N-4 shows that 1/2 inch size is too small for 205 CFH at 50 ft. but 3/4 inch can handle 375 CFH.
- The correct size is 3/4 inch.

3. To size SECTION B, the distance from the meter to the range is 30 ft (10+20) A+B:

- Load is 55 CFH (55,000 BTU).
- Table N-4 shows that 3/8 inch size can handle 90 CFH.
- The correct size for section B is 3/8 inch.

4. To size SECTION C, the distance from the meter to the water heater is 20 ft (10+10) A+C:

- Load is 40 CFH (40,000 BTU).
- Table N-4 shows that that 3/8 inch size can handle 112 CFH.
- The correct size for section C is 3/8 inch.

5. To size SECTION D, the distance from the meter to the dryer is 50 ft (10+40) A+D:

- Load is 30 CFH (30,000 BTU).
- Table N-4 shows that that 3/8 inch size can handle 69 CFH at 50 feet
- The correct size for section D is 3/8 inch.

6. To size SECTION E, the distance from the meter to the furnace is 20 ft (10+10) A+E:

- Load is 80 CFH (80,000 BTU)
- Table N-4 shows that 3/8 inch size can handle 112 CFH at 20 feet
- The correct size for section E is 3/8 inch.

EXAMPLE 3: ELEVATED PRESSURE 2 PSI SYSTEM-PARALLEL ARRANGEMENT

1. The system shown in Figure: 3-3 is adapted for multifamily or single family application with an extended (100 feet) tubing run from

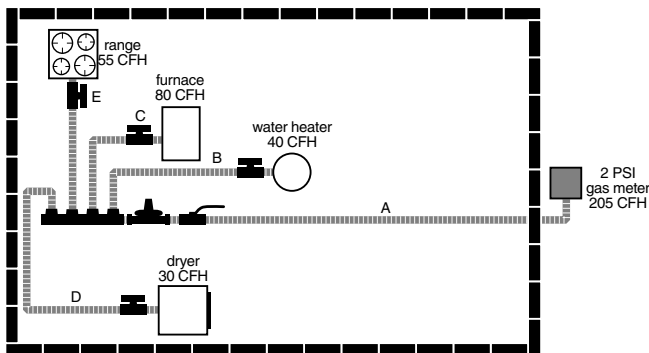
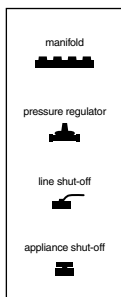

Figure: 3-3



LENGTH OF RUNS

- A = 100 Feet
- B = 15 Feet
- C = 10 Feet
- D = 25 Feet
- E = 20 Feet

Supply pressure 2 PSI
 Allowable drop: 1 PSI up to reg.
 3 inches w.c.-reg. to appliance

the meter to the regulator. The 2 PSI system is well adapted to handle the long runs required in multifamily buildings with centralized meter banks.

2. To size section A determine the entire gas load it will deliver:

- furnace + water heater + dryer + range = 80 CFH + 40 CFH + 30 CFH + 55 CFH = 205 CFH (205,000 BTUH) Select Table N-5 “Elevated Pressure 2 PSI with 1 PSI drop”. This is the standard table chosen to stay within the FGP-REG-3 regulator capacity. See note below.
- Length is 100 ft.
- Table N-5 shows that 3/8 inch size is too small for 205 CFH but 1/2 inch can handle 226 CFH.
- The correct size is 1/2 inch.

3. To size each of the other sections:

Select Table N-3 “Regulator Outlet 8.0 inches w.c with a drop of 3.0 inches w.c

- Section B is 15 feet with a 40 CFH load 3/8 inch has a capacity of 90 CFH.
- Section C is 10 feet with a 80 CFH load 3/8 inch has a capacity of 112 CFH.
- Section D is 25 feet with a 30 CFH load 3/8 inch has a capacity of 69 CFH.
- Section E is 20 feet with a 55 CFH load 3/8 inch has a capacity of 78 CFH.
- The correct size for all these runs is 3/8 inch.

Supply Pressure and Capacities

Based on flow in cubic feet per hour natural gas

P/N	1/2 PSI (34 mbar)	3/4 PSI (52 mbar)	1 PSI (69 mbar)	1-1/2 PSI (103 mbar)
FGP-REG-3	145 (4.1)	200 (5.7)	250 (7.1)	250 (7.1)
FGP-REG-5A	335 (9.5)	475 (13.5)	550 (15.6)	500 (15.6)
FGP-REG-7L	690 (19.5)	970 (27.5)	1000 (28.3)	1000 (28.3)

EXAMPLE 4: MEDIUM PRESSURE 12-14 INCHES W.C. 1/2 PSI) PARALLEL SYSTEM WITH A SERIES BRANCH

1. The system shown in Figure: 3-4 has a barbeque installed nearby the range. A parallel arrangement was chosen for the medium pressure system (12 inch W.C. with 6 inches W.C. drop) with a single run feeding both range and barbeque in series.

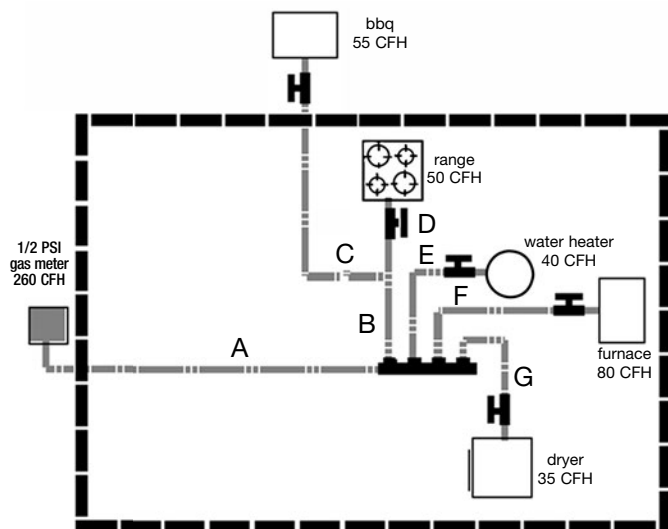

Figure: 3-4

LENGTH OF RUNS

- A = 20 Feet
- B = 35 Feet
- C = 20 Feet
- D = 10 Feet
- E = 10 Feet
- F = 10 Feet
- G = 15 Feet

2. To size SECTION A, determine the length of the longest run from the meter and the entire gas load it must deliver:

- Range + barbeque + water heater + furnace + dryer = 260 CFH (260,000 BTUH).
- Meter to barbeque is 75 ft (A+B+C) This is the longest length.
- Select Table N-4 Medium Pressure. Table N-4 shows that 1 inch is required for 260 CFH at 75 ft.
- The correct size is 3/4 inch.

3. To size SECTION B, the line from the manifold serves both the range and the barbeque:

- Total load is 105 CFH (110,000 BTUH).
- Longest length is 75 feet (A+B+C) from the meter to the barbeque.
- Table N-4 shows that size 1/2 inch can handle 120 CFH at 75 ft.
- The correct size is 1/2 inch.

4. To size SECTION C, the distance from the meter to the barbeque is 75 ft (A+B+C):

- Load is 55 CFH (55,000 BTUH).
- Table N-4 shows that size 3/8 inch can handle 55 CFH at 80 ft.
- The correct size is 3/8 inch.

5. To size SECTION D, the distance from the meter to the range is 65 ft (A+B+D):

- Load is 50 CFH (50,000 BTUH).
- Table N-4 shows that size 3/8 inch can handle 58 CFH at 70 ft.
- The correct size is 3/8 inch.

6. To size SECTION E, the distance from the meter to the water heater is 30 ft (A+F):

- Load is 40 CFH (40,000 BTUH).
- Table N-4 shows that size 3/8 inch can handle 90 CFH at 30 ft.
- The correct size is 3/8 inch.

7. To size SECTION F, the distance from the meter to the furnace is 30 ft (A+E):

- Load is 80 CFH (80,000 BTUH).
- Table N-4 shows that size 3/8 inch can handle 90 CFH at 30 ft.
- The correct size is 3/8 inch.

8. To size SECTION G, the distance from the meter to the dryer is 35 ft (A+G):

- Load is 35 CFH (35,000 BTUH).
- Table N-4 shows that size 3/8 inch can handle 78 CFH at 40 ft.
- The correct size is 3/8 inch.

SECTION 3.2.3 – SIZING HYBRID SYSTEMS - Black Iron and *TracPipe*® *CounterStrike*® Combination

To size a commercial or a residential system with a rigid black iron trunk line and flexible *TracPipe*® *CounterStrike*® branches feeding the appliances, you will need both the standard gas piping capacity tables for black iron printed in many plumbing and mechanical codes (and contained in both National and International Fuel Gas Code) and the *TracPipe*® *CounterStrike*® Capacity Tables printed later in this manual.

NOTICE: Black iron pipe capacity table is provided in this design guide Section 7.2.

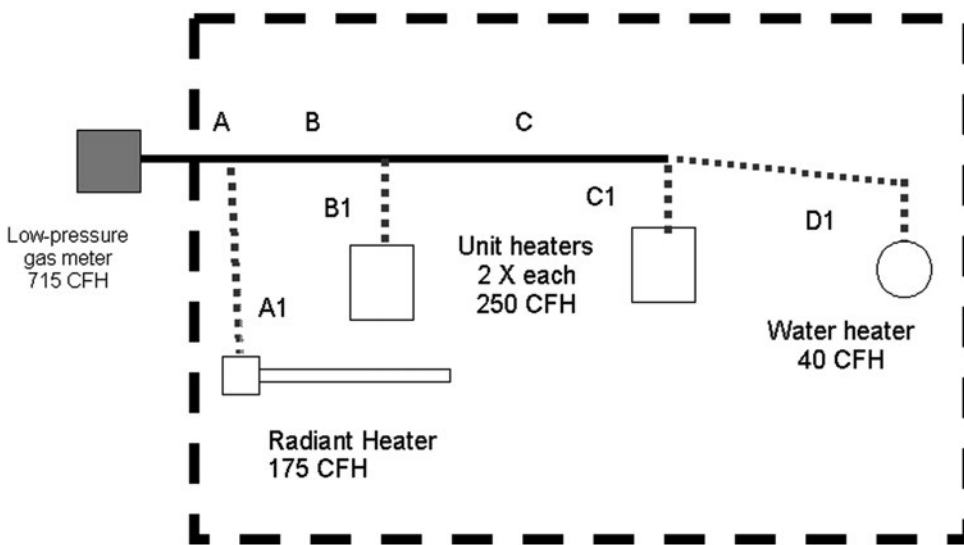

Figure: 3-5

LENGTH OF RUNS
 A = 15 Feet C = 20 Feet
 A1 = 45 Feet C1 = 5 Feet
 B = 15 Feet D1 = 20 Feet
 B1 = 10 Feet

EXAMPLE 5: LOW PRESSURE HYBRID SYSTEM Black Iron and *CounterStrike*® Combination - SERIES ARRANGEMENT

1. The system shown in Figure: 3-5 is a typical commercial building with 4 appliances. The gas pressure for this example is standard low pressure with 6-inch supply pressure and 0.5-inch pressure drop.
2. To determine rigid pipe size (section A) determine the longest run from the meter to the furthest appliance:
 Meter to water heater Add A + B + C + D1 = 70 ft. Total Load is 715 CFH (715,000 BTU)

Section A correct size is 1 1/2 inch black pipe.

3. To determine rigid pipe size (section B) reduce load by the load carried in section A1 to Radiant Heater (175 CFH). Use same number for length: 70 ft. is longest run. Load for this section is 540 CFH. Section B correct size is 1 1/2 inch black pipe.
4. To determine rigid pipe size (section C) reduce load further by the load carried in section B1 to first unit heater (250 CFH). Use same number for length: 70 ft. is longest run. Load for this section is 290 CFH. Section C correct size is 1 1/4 inch black pipe.

5. To determine *TracPipe*® *CounterStrike*® sizing for the branch runs the length to be used is the total length of black pipe plus *TracPipe*® *CounterStrike*® from the meter to that appliance. The load used is the load of the individual piece of equipment.

6. To determine the size of *TracPipe*® *CounterStrike*® (section D1) the length is 70 ft and the load is 40 CFH. Using Table N-1: Section D correct size is 3/4 inch.

7. To determine the size of *TracPipe*® *CounterStrike*® (section C1) the length is 55 ft and the load is 250 CFH. Using Table N-1: Section C1 correct size is 1 1/4 inch.
8. To determine the size of *TracPipe*® *CounterStrike*® (section B1) the length is 40 ft and the load is 250 CFH. Using Table N-1: Section B1 correct size is 1 1/4 inch.
9. To determine the size of *TracPipe*® *CounterStrike*® (section A1) the length is 60 ft and the load is 175 CFH. Using Table N-1: Section A1 correct size is 1 1/4 inch.

EXAMPLE 6: LOW PRESSURE HYBRID SYSTEM -Black Iron and CounterStrike® Combination - SERIES ARRANGEMENT

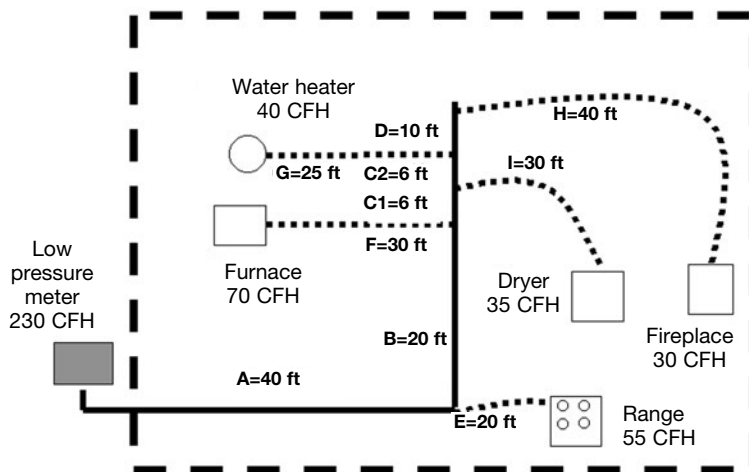

Figure: 3-6

1. The system presented in Figure: 3-6 is a typical residence with 5 appliances. The supply pressure is 7 inches w.c. The allowable drop is 1.0 inch w.c. total.

NOTICE: Check with your local inspection department and/or gas utility before sizing any low-pressure system with a total drop of more than 0.5 inch w.c.

2. The black iron trunk line (A+B+C1+C2+D) will first be sized for a drop of 0.5 inch, w.c. in accordance with the standard method (longest total run) and each **TracPipe® CounterStrike®** branch run to an appliance will then be sized for 1.0 inch w.c. drop based on the length from that appliance back to the meter. The maximum pressure drop to each appliance will be 1.0 inch w.c.
3. The longest total run is 122 ft. (total length of all black iron sections and **TracPipe® CounterStrike®** section to the furthest appliance). The total load is 70+40+55+35+30=230 CFH. Correct size for A is 1-1/4 inch.
4. Section B, the longest run remains 122 ft but the load is reduced to 175 CFH. Correct size is 1 inch.

5. Section C1, the longest run is 122 ft and load is reduced to 105. Correct size is 1 inch.
6. Section C2, the longest run is 122 ft and load is reduced to 70. Correct size is 3/4 inch.
7. Section D, the longest run is 122 ft and load is reduced to 30. Correct size is 1/2 inch.
8. Section E, length is 60 ft and the load is 55 CFH. From Table N-2A the correct size is 1/2 inch.
9. Section F, length is 90 ft and the load is 70 CFH. From Table N-2A the correct size is 3/4 inch.
10. Section G, length is 97 ft and the load is 40 CFH. From Table N-2A the correct size is 1/2 inch.
11. Section H, length is 122 ft and the load is 30 CFH. From Table N-2A the correct size is 1/2 inch.
12. Section I, length is 96 ft and the load is 35 CFH. From Table N-2A the correct size is 1/2 inch.

EXAMPLE 7: LOW PRESSURE HYBRID STEEL PIPE AND CounterStrike® -PARALLEL ARRANGEMENT-MANIFOLD-USING THE BRANCH LENGTH METHOD

1. The system presented in Figure: 3-7 is typical of a residential installation with four appliances. The supply pressure is 7-8 inches water column. The system will be sized with 0.5 inches w. c. drop for the steel pipe trunk line and 1.0 inch w.c. drop for the **TracPipe® CounterStrike®** branches.

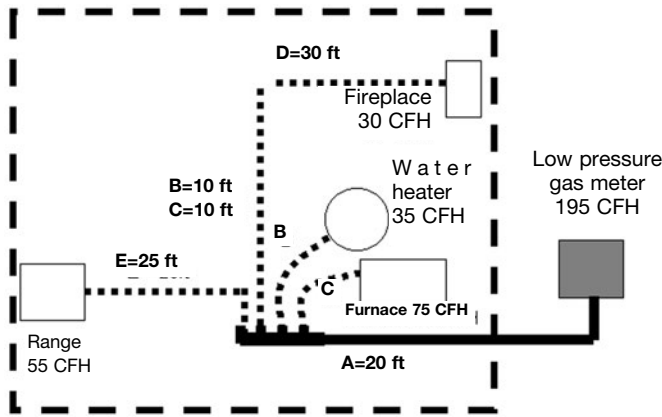

Figure: 3-7

- To size the steel pipe trunk line, determine the longest run from the meter to the most remote appliance and the total load. The longest run is to the fireplace:
 - Meter to fireplace is 50 ft (A + D).
 - Total load is 195 CFH (75 + 35 + 30 + 55).
 Using steel pipe Table: SP-1 following the 50 ft column down, the correct size for the steel pipe is 1 inch.

- To determine the size of the **TracPipe® CounterStrike®** run “C” to the furnace use the load through that branch (75 CFH) and calculate the length from the meter to the furnace:
 - Meter to furnace is 30 ft (A + B).
 - Furnace load is 75 CFH.
 Using Table N-2A the 1.0-inch w.c. pressure drop chart for **TracPipe® CounterStrike®**. Follow the 30 ft column down, the correct size for the furnace branch line “C” is 1/2 inch.

- To determine the size of the **TracPipe® CounterStrike®** run “B” to the water heater use the load through that branch (35 CFH) and calculate the length from the meter to the water heater:
 - Meter to water heater is 30 ft (A + C).
 - Water heater load is 35 CFH.
 Using Table N-2A the 1.0 inch w.c. pressure drop chart for **TracPipe® CounterStrike®**. Follow the 30 ft column down, the correct size for the water heater branch line “B” is 3/8 inch.

- To determine the size of the **TracPipe® CounterStrike®** run “D” to the fireplace use the load through that branch (30 CFH) and calculate the length from the meter to the fireplace:
 - Meter to fireplace is 50 ft (A + D).
 - Fireplace load is 30 CFH.
 Using Table: N-2A (the 1.0 inch w.c. pressure drop chart for **TracPipe® CounterStrike®**). Follow the 50 ft column down, the correct size for the fireplace branch line “D” is 1/2 inch.

- To determine the size of the **TracPipe® CounterStrike®** run “E” to the range use the load through that branch (55 CFH) and calculate the length from the meter to the range:
 - Meter to range is 45 ft (A + E).
 - Range load is 55 CFH.
 Using Table: N-2A the 1.0 inch w.c. pressure drop chart for **TracPipe® CounterStrike®**. Follow the 50 ft column down, the correct size for the range branch line “D” is 1/2”.

- To determine the size of the **TracPipe® CounterStrike®** run “E” to the range use the load through that branch (55 CFH) and calculate the length from the meter to the range:
 - Meter to range is 45 ft (A + E).
 - Range load is 55 CFH.
 Using Table: N-2A the 1.0 inch w.c. pressure drop chart for **TracPipe® CounterStrike®**. Follow the 50 ft column down, the correct size for the range branch line “D” is 1/2”.

SECTION 3.2.4 – ALTERNATE SIZING METHOD: SUM OF PRESSURE LOSS CALCULATIONS

- In addition to the longest run sizing method, there is another approach to pipe sizing, which yields results closer to the actual friction loss results (obtained from testing) for each section of an installed gas piping system. This engineered approach “Sum of Pressure Loss Calculations” avoids the simplified, conservative approximations of the longest run method. Mechanical engineers who design piping systems understand that placing a building’s entire load (theoretically) at the farthest equipment outlet is not only inaccurate but will often yield pipe sizes which are larger than necessary. The longest run method was devised at a time when gas utilities could not always guarantee a constant pressure at every meter during times of high demands; it is a conservative approach and, although it is the customary sizing approach in North America, other engineered calculations are permitted by most codes.

- Pressure loss calculations which sum up friction losses in each section of a gas piping system can provide a system design with more accurate and possibly smaller piping diameters than the traditional longest run method. These calculations utilize pressure loss charts for each size of CSST, which have been developed from actual test results. The maximum flow capacity is predicted with more precision than with the longest run method. The Sum of Pressure Loss method is described below with tables providing pressure loss per foot based upon the total load supplied by that length of pipe with all appliances operating.
- The system designer has simply to determine the load and the length for each run. A tentative size is chosen and pressure loss in that leg is determined by multiplying the loss per foot (inches w.c. from the chart) by the length. Starting at the meter and working outward the pressure loss for each leg is then summed up until the farthest appliance is reached. The total calculated loss is then compared with the allowable loss, which must not be exceeded from the meter to the farthest appliance. The allowable pressure loss for each system is the responsibility of the system designer, based on model codes and on the available pressure at the meter set (or second stage regulator) and the pressure required for each appliance (usually found on the manufacturer's data plate.) Current language in many model codes states: The allowable loss under maximum probable flow conditions, from the point of delivery to the inlet connection of the appliance, shall be such that the supply pressure at the appliance is greater than the "minimum inlet pressure" as stated on the appliance manufacturer's data plate. If the initial proposed design calculation yields a total pressure loss, which is higher than allowed, simply go back and calculate again with larger sizes, starting from the meter.

USING SUM OF PRESSURE LOSS METHOD EXAMPLE 8: LOW PRESSURE SYSTEM

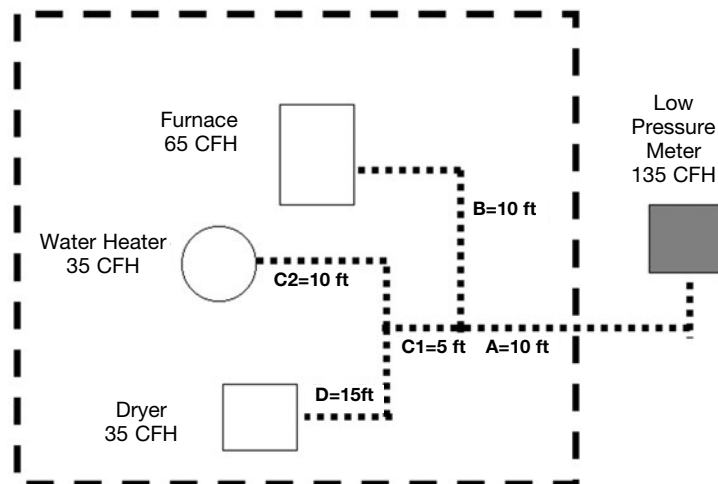

Figure: 3-8

SERIES ARRANGEMENT

- The system presented in Figure: 3-8 is similar to that in 3-1, a single-family installation with the addition of one more appliance, a dryer. The supply pressure is 6 inches water column and the allowable pressure drop is 0.5 inch.
- To size section A, calculate the load carried by that section:
 - Furnace plus Water Heater plus Dryer = 135 CFH (MBTU).
 Using Table PD-1A find pressure loss at 135 MBTU load through 3/4 inch **TracPipe® CounterStrike®**. Average of 0.0135 and 0.0158 is 0.0147. Drop per foot is 0.0147; multiply by length 10 feet = 0.147 drop.
- To size section B find the drop per foot for the load carried by that section:
 - Furnace Load 65 CFH (MBTU).
 Using Table PD-1A find pressure loss at 65 MBTU through 1/2 inch **TracPipe® CounterStrike®**. Use the average of loss between 60 and 70 MBTU: Average of 0.0177 and 0.0244 is 0.0211; Drop per foot is 0.0211; Multiply by length 10 feet = 0.211 drop.

Sum pressure loss meter to Furnace
 $0.147 + 0.211 = 0.358$ inch w.c.

This leg is sized properly at 1/2 inch because sum of loss is less than 0.5 inch w.c.

- To size section C1 find the drop per foot for the load carried by that section:

- 70 CFH (MBTU)

Using Table PD-1A find pressure loss at 70 MBTU load through 1/2 inch **TracPipe® CounterStrike®**

Drop per foot is 0.0244; length is 5 ft; 5 X 0.0244 is 0.122.

- To size section C2 find the drop per foot for the load carried by that section:

- 35 CFH (MBTU)

Using Table: PD-1A find pressure loss at 35 CFH load through 1/2 inch **TracPipe® CounterStrike®** Average of 0.0077 and 0.0042 is 0.0060; length is 10 ft; 10X 0.006 is 0.06. Sum pressure loss to water heater $0.147 + 0.122 + 0.06 = 0.329$ inch w.c. This leg is sized properly at 1/2 inch because sum of loss is less than 0.5 in. w.c.

- To size section D find the drop per foot for the load carried by that section:

- 35 CFH (MBTU)

Using Table: PD-1A find pressure loss at 35 CHF MBTU through 1/2 inch **TracPipe® CounterStrike®** Drop per foot is 0.006 (See number 4 above); Multiply by length 15 feet = 0.09. Sum pressure loss to dryer $0.147 + 0.122 + 0.09 = 0.359$ inch w.c.

This leg is sized properly at 1/2 inch because sum of loss is less than 0.5 in. w.c.

The sum of pressure loss method allows the addition of an appliance without increasing trunk line size.

EXAMPLE 9: LOW PRESSURE HYBRID SYSTEM - TracPipe® CounterStrike® Steel Pipe and Combination - SERIES ARRANGEMENT USING SUM OF PRESSURE LOSS METHOD

- The system presented in Figure: 3-9 is identical to that in Figure: 3-6 a single-family installation with 5 appliances. Low pressure 6-7 inches and a pressure drop of 0.5 inches water column. **NOTICE:** in Example: 6 this system was sized using the longest run method. Here we will use the sum of pressure loss method discussed in section 3.2D.

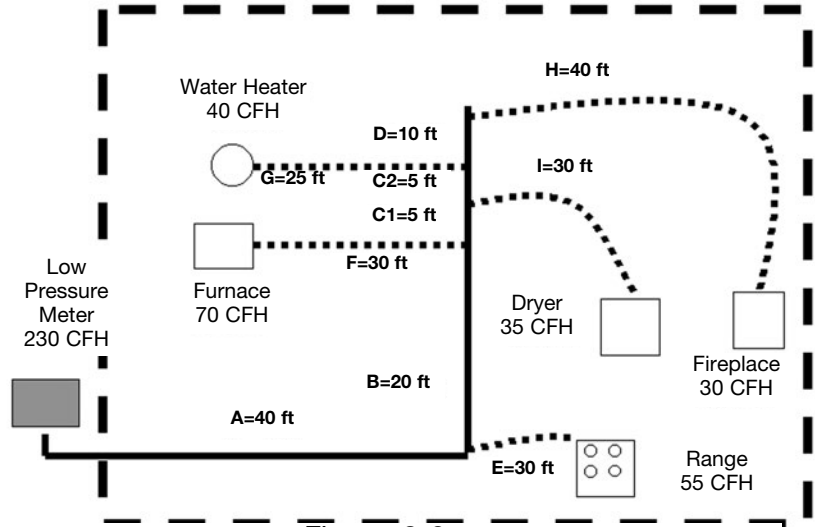

Figure: 3-9

- Begin by using pipe sizes determined in Example: 6 and determine if these are correct with this method. It is possible that smaller pipe sizes may be sufficient; this will be determined by calculating the sum of pressure losses from the meter to each appliance. To use this method a tentative size will be assigned to each run and this size will be confirmed or revised by the calculation. The sum total loss of a run from the meter to the appliance cannot exceed the allowable pressure loss.
- To determine pressure loss through section A (steel pipe trunk), use the load through that section (230 CFH) for 1-1/4 inch steel pipe and find the pressure loss per foot using Table: PD-2A. (Since 230 CFH is not listed in the chart you must extrapolate the pressure drop using the two flow rates above and below the desired capacity.) This would equate to approximately 0.0018 inch w.c. Pressure drop per foot. Multiply the length: 40 feet by the loss per foot: 0.0018. The pressure loss for this section is 0.072.
- To determine the pressure loss through section B, we use the load through that section (175 CFH). Find the loss for 1 inch size using Table: PD-2A. This would be approximately 0.0041 inch w.c. per foot. Multiply the length: 20 feet by the loss per foot: 0.0041. The pressure loss for this section is 0.0820.

5. To determine the pressure loss through section C1 we use the load through that section (105 CFH). Find the pressure loss for 1 inch using Table: PD-2A. This would be approximately 0.0016 inch w.c. Multiply the length: 5 feet by the loss per foot 0.0016. The pressure loss for this section is 0.0080" w.c.
6. To determine pressure loss through section C2 we use the load through that section (70 CFH). Find the pressure loss for 3/4 inch using Table: PD-2A. This would be 0.0024' w.c. Multiply the length: 5 feet by the loss per foot: 0.0024. The pressure loss for this section is 0.0120' w.c.
7. To determine pressure loss through section D we use the load through that section (30 CFH). Find the pressure loss for 1/2 inch using Table: PD-2A. This would be 0.0020" w.c. Multiply the length: 10 feet by the loss per foot: 0.0020. The pressure loss for this section is 0.0200" w.c.
8. To determine pressure loss through section E (**TracPipe® CounterStrike®** drop to range) use the load through that section (55 CFH) and extrapolate the pressure loss using Table: PD-1A. Trying the 3/4 inch column we find that the pressure loss would be approx 0.0029 inch w.c. Multiply the length: 30 feet by the loss per foot 0.0029. The pressure loss for this section is 0.0870. Add the loss of section A to the loss of section E for the total loss from the meter to the range. $0.072 + 0.0870 = 0.159$. Since this is less than the 0.5 inch w.c. allowable drop the correct size for section E is 3/4 inch.
9. To determine pressure loss through section F (**TracPipe® CounterStrike®** drop to the furnace), use the load (70 CFH) and find pressure loss from Table: PD-1A. In the 3/4 inch column we find 0.0038. Multiply the length: 30 feet by 0.0038. The pressure loss for this section is 0.1140. Add the loss of sections A + B to the loss of section F for total loss from meter to furnace. $0.072 + 0.082 + 0.114 = 0.2680$. The correct size for section F is 3/4 inch.
10. To determine pressure loss through section G (**TracPipe® CounterStrike®** drop to the water heater), use the load (40 CFH) and find pressure loss from Table: PD-1. In the 1/2 inch column we find 0.0077. Multiply the length: 25 feet by 0.008. The pressure loss for this section is 0.1925. Add the loss of sections A + B + C1 + C2 to the loss of section G for total loss from meter to furnace. $0.072 + 0.0820 + 0.0080 + 0.0120 = 0.1740$. The correct size for section G is 1/2 inch.
1. To determine pressure loss through section H (**TracPipe® CounterStrike®** drop to the fireplace), use the load (30 CFH) and find pressure loss from Table: PD-1. In the 1/2 inch column we find 0.0042. Multiply the length: 40 feet by 0.0042. The pressure loss for this section is 0.1680. Add the loss of sections A + B + C1 + C2 + D to the loss of section H for total loss from meter to furnace. $0.072 + 0.0820 + 0.0080 + 0.0120 + 0.1680 = 0.3420$. The correct size for section H is 1/2 inch.
12. To determine pressure loss through section I (**TracPipe® CounterStrike®** drop to the dryer), use the load (35 CFH) and find pressure loss from Table: PD-1. In the 1/2 inch column we find 0.006. Multiply the length: 30 feet by 0.006. The pressure loss for this section is 0.18. Add the loss of sections A + B + C1 to the loss of section I for total loss from meter to dryer. $0.072 + 0.0820 + 0.0080 + 0.18 = 0.3420$. The correct size for section I is 1/2 inch. Using the Sum of Pressure Loss Method we calculate that three of the five **TracPipe® CounterStrike®** sections (when compared with the longest length method) can utilize reduced sizes to deliver the necessary load with a pressure loss equal to or less than the allowable 0.5 inches water column. This enables the installer to use 1/2 inch **TracPipe® CounterStrike®** on all but the furnace and range drops, which remain 3/4 inch.

CHAPTER 4 INSTALLATION PRACTICES

SECTION 4.1 – GENERAL INSTALLATION PRACTICES

Precautions must be taken to ensure that any exposed flexible piping is not damaged or abused during building construction. All system hardware should be stored in a secure, dry location prior to installation.

1. The piping system is for use with fuel gas at operating pressures up to 25 PSI (USA and Canada restriction). **TracPipe® CounterStrike®** gas piping (3/8 inch up to 1-1/4 inch sizes) has been tested and is approved for pressures up to 125 PSI, and may ONLY be used at this pressure with the consent of the local gas utility and code authority. Pressure tests up to 125 PSI are permitted on sizes up to 1-1/4 inch.
2. Only components provided by **OmegaFlex®** or specified as part of the **TracPipe® CounterStrike®** piping system are to be used in the installation.

Do not use **TracPipe® CounterStrike®** tubing or fittings with tubing or fittings of any other manufacturer. Intermixing of CSST tubing or fitting components between CSST manufacturers is prohibited. Connections between two different brands of CSST may be accomplished using standard malleable iron fittings.

3. Ends of the piping are to be temporarily capped, plugged or taped closed prior to installation and pulling through structure to prevent entrance of dirt, or other debris.
4. **⚠️WARNING:** Contact with sharp objects or harmful substances is to be avoided. Contact with any chemicals containing chlorides or ammonia must be followed by thorough rinse and wipe dry. Typical chloride based chemicals include fluxes used for soldering copper tubes and acid based cleaners such as muriatic acid used for cleaning brickwork. Use only non-corrosive leak detection fluids. (Available: TracPipe Leak Check Solution P/N FGP-LCS). Call customer Service.

5. BENDING **TracPipe® CounterStrike®**

Undue stress or strain on the tubing or fittings is to be avoided. Bending flexible gas piping is one feature which contributes to the speed of installation. Multiple tight bends can restrict the gas flow and increase pressure drop. The tightest bend allowed for each size of **TracPipe® CounterStrike®** is shown in Table: 4-1.

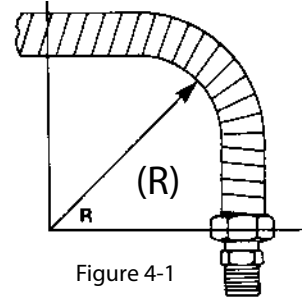

Figure 4-1

MINIMUM BENDING RADIUS FOR FLEXIBLE GAS PIPING

Table: 4-1

TUBING SIZE	MINIMUM BEND RADIUS (R)
3/8 inch	9/16 inch
1/2 inch	3/4 inch
3/4 inch	1 inch
1 inch	3 inch
1-1/4 inch	3 inch
1-1/2 inch	3 inch
2 inch	4 inch

Typical locations requiring tight bends are termination mount installations in hollow stud walls.

6. SUPPORTING

TracPipe® CounterStrike® Piping shall be supported in a workmanlike manner with pipe straps, bands, brackets or hangers suitable for the size and weight of the piping. **TracPipe® CounterStrike®** which passes over or through a structural member is considered to be supported by that member.

6A. VERTICAL RUNS

Spacing of supports is not to exceed 10 feet, requiring hangers only where the height of each floor is greater than 10 feet.

6B. HORIZONTAL RUNS

Spacing of supports Hangers, supports and anchors-Piping shall be supported at intervals not to exceed those shown in Table: 4-2.

NOTICE: Some codes do not allow the use of plastic hangars for gas piping systems.

HORIZONTAL OR INCLINED RUNS

Table: 4-2

PIPING SIZE	SPACING OF SUPPORTS
3/8 inch	4 FEET
1/2 inch	6 FEET
3/4 inch	8 FEET
1 inch	8 FEET
1-1/4 inch	8 FEET
1-1/2 inch	8 FEET
2 inch	8 FEET

SECTION 4.2

Section 4.2.1 HOW TO ASSEMBLE *TracPipe*® *AutoFlare*® FITTINGS

1. **CUT-TO-LENGTH:** Determine proper length. Cut through plastic jacket and stainless tube using a tube cutter with a sharp wheel. Cut must be centered between two corrugations. Use full circular strokes in one direction and tighten roller pressure slightly (a quarter turn) after each revolution. **DO NOT OVERTIGHTEN ROLLER**, which may flatten tube. Figure: 4-2

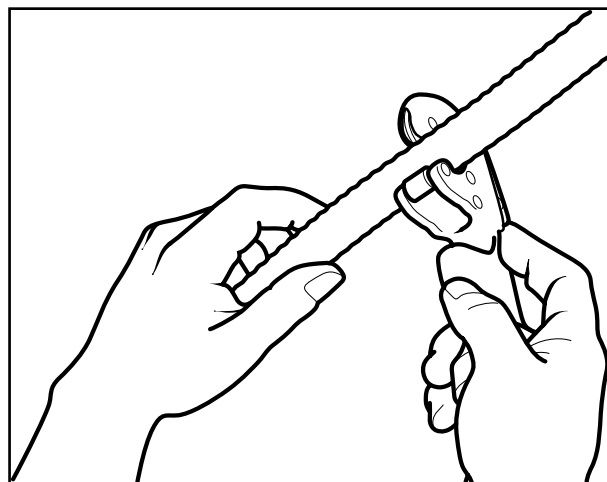

Figure: 4-2

NOTICE: Due to the large diameter and depth of corrugation on sizes over 1 inch, tubing must be cut with a standard tubing cutter RIDGID™ 152 or equal using a ***TracPipe*® *CounterStrike*®** cutting wheel no. FGP-E-5272 (P/N E-5272 or equal).

⚠ CAUTION:

Use of a small cutting wheel may flatten the first corrugation and make cutting and/or sealing of fittings difficult.

2. **STRIP JACKET:** Using a utility knife, strip back the jacket. See Table: 4-3 for maximum jacket strip length. Care should be taken to minimize the amount of jacket material removed. Figure: 4-3, 4-4

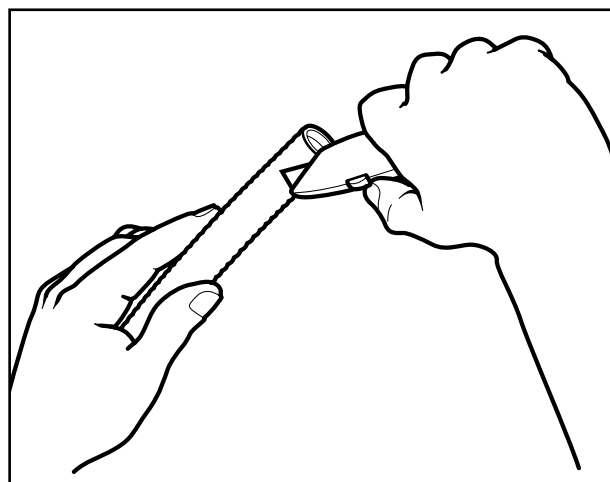

Figure: 4-3

⚠ CAUTION:

For your personal safety--Knife blade and cut tube ends are both sharp. Use care when cutting the jacket and handling the tube.

Table: 4-3
MAXIMUM STRIP LENGTH

Tubing Size		FST Fittings	Termination Type and PS-II Fittings
3/8"	-375	1-1/8"	1-1/2"
1/2"	-500	1-3/16"	1-1/2"
3/4"	-750	1-1/4"	1-3/4"
1"	-1000	1-3/8"	2"
1-1/4"	-1250	1-5/8"	2-1/4"
1-1/2"	-1500	1-5/8"	2-1/2"
2"	-2000	2"	2-3/4"

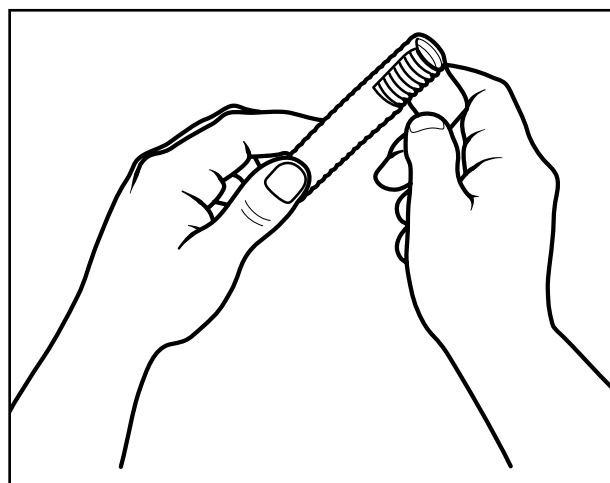

Figure: 4-4

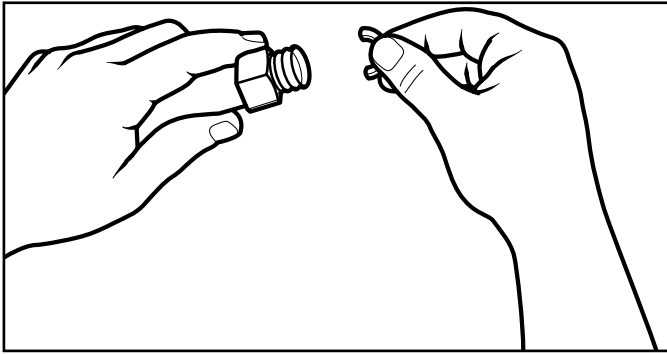

Figure: 4-5

3. **INSTALL FITTING NUT:** Slide nut over cut end: place two split-rings into the first corrugation next to the tube cut. Slide nut forward to trap the rings. Figure: 4-5

4. **WRENCH FITTING:** Place the adapter into the nut and engage threads. Note that the **TracPipe® AutoFlare®** fitting is designed to form a leak tight seat on the stainless tubing as you tighten the fitting. (The piloting feature of the adapter will not always enter the bore of the tubing before the tightening operation, but will center the fitting when tightened). Using appropriate wrenches, tighten the fitting until adapter bottoms and the resistance to wrenching increases greatly. The flare has now been created on the tubing end.

⚠ WARNING: Do not use any thread sealants for this connection. Sealants are to be used on the pipe thread only.

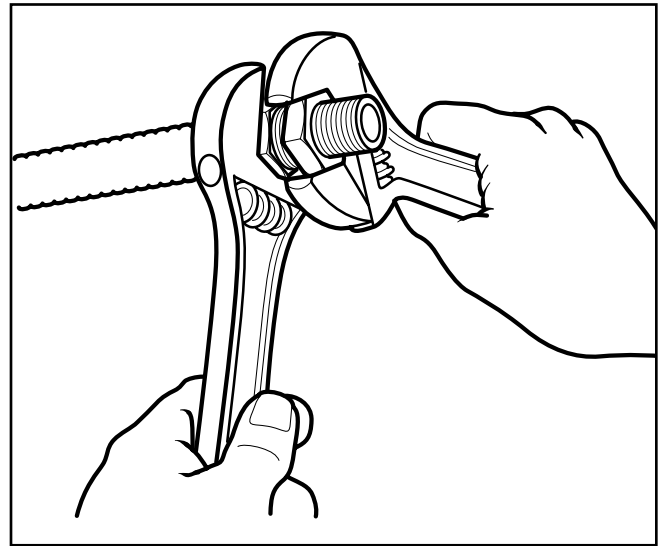

Figure: 4-6

Table: 4-4

Flexible Pipe Size	Fitting	Torque Value
3/8" FGP-CS-375	FGP-FST-375	40 ft.-lb.
1/2" FGP-CS-500	FGP-FST-500	42 ft.-lb.
3/4" FGP-CS-750	FGP-FST-750	45 ft.-lb.
1" FGP-CS-1000	FGP-FST-1000	75 ft.-lb.
1-1/4" FGP-CS-1250	FGP-FST-1250	150-200 ft.-lb.
1-1/2" FGP-CS-1500	FGP-FST-1500	200-250 ft.-lb.
2" FGP-CS-2000	FGP-FST-2000	250-300 ft.-lb.

5. **FINAL TORQUE:** Tighten nut and adapter to the torque values shown in Table 4-4. When a torque wrench is not available, use the following method: Tighten nut and adapter as though you were making up a flared tubing joint. Note relation between hex flats at this point and continue to tighten for two additional hex flats (one-third turn) to obtain required torque and final leak-tight seal. Figure: 4-6

Section 4.2.2 HOW TO ASSEMBLE *TracPipe*® *AutoSnap*® FITTINGS

⚠ WARNING: These instructions must be followed for installing *TracPipe*® *AutoSnap*® fittings to *TracPipe*® *CounterStrike*® flexible gas piping.

⚠ WARNING: Do not use pipe sealants on any part of these fittings except the NPT threads. Use of pipe wrenches is not recommended and may cause damage to the fittings. Use adjustable or open end wrenches whenever possible.

- 1. CUT PIPE:** Determine proper pipe length and cut through the plastic jacket and stainless steel pipe using a tubing cutter with a sharp wheel. Use full circular rotations in one direction, gradually tightening roller pressure after each revolution until a clean cut is obtained. Avoid over-tightening roller as this may flatten the crowns of the corrugations and interfere with a gas tight seal. Inspect pipe for a clean cut without tears or distortion.

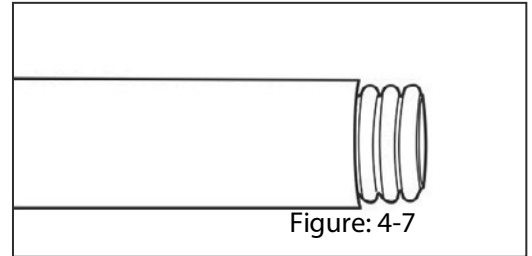

NOTICE: Due to the corrugation depth on pipe sizes over 1", a RIDGID™ 152 or equal tubing cutter with a special, hardened *TracPipe*® *CounterStrike*® FGP-E-5272 cutting wheel must be used or damage to the pipe corrugations will occur making sealing difficult. A RIDGID™ plastic cutting wheel is not suitable, and will chip/ break.

- 2. STRIP JACKET:** Using a utility knife with a sharp blade, strip back the jacket so THREE corrugation peeks are exposed for straight fittings and couplings and strip FIVE corrugations for termination fittings. This is critical for proper insertion of pipe into fitting. Figure: 4-7

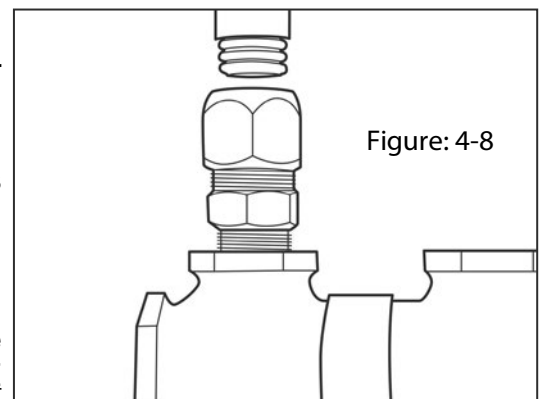

⚠ CAUTION: Knife blade and pipe ends are very sharp. Use care when stripping jacket and handling tubing.

INSTALLING STRAIGHT FITTINGS AND COUPLINGS

- 3. NPT CONNECTION:** For couplings, skip this step. For straight fittings, connect NPT threaded end to termination point, i.e. manifold or appliance, using thread sealant. Tighten fitting to termination point using an adjustable wrench on the body hex only. Figure: 4-8

Do not make this connection by tightening the nut, or the assembly of the fitting to the pipe will not be possible without disassembly and reassembly of the fitting components.

- 4. PIPE TO FITTING CONNECTION:** This step applies to straight and coupling fittings. Loosen nut on the fitting 1 to 1-1/2 turns. Straighten pipe end and insert into the back of the fitting until it snaps into place. Figure: 4-9 **While holding the tubing firmly into the fitting, tighten the nut by hand to capture the first corrugation. If inserted correctly, a gradual resistance to tightening by hand will be felt. If a dead stop is felt, the pipe is not inserted properly, back off nut, make sure the pipe is in completely and straight and re-tighten by hand to confirm proper fit. Check to make sure the tubing is captured by pulling on the tubing. If the tubing has been captured, use adjustable wrenches and continue**

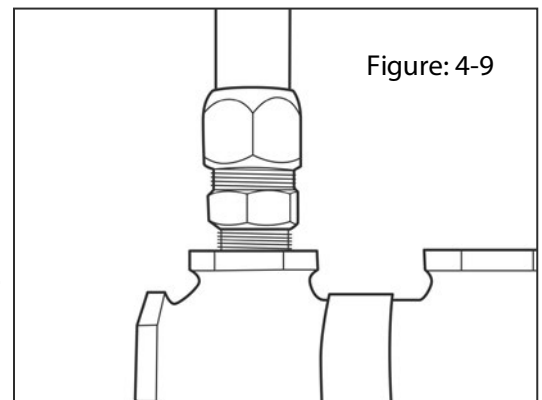

to tighten the nut to the specified torque value or until resistance has greatly increased. Table 4-5 When the nut is fully tightened leak tight, there should be no more than ½ to 1 thread showing behind the nut.

5. USE A SECOND ADJUSTABLE END WRENCH ON THE FITTING BODY AS A BACK UP WHILE TIGHTENING THE NUT. HOLDING THE NUT AND TIGHTENING BY TURNING BODY MAY CAUSE THE PIPE TO TWIST. OVER TIGHTENING THE NUT MAY CAUSE DEFORMATION THAT WILL NOT ALLOW THE FITTING TO BE REUSED.

Size	Min Torque (ft-lbs)
3/8"	25
1/2"	30
3/4"	40
1"	45
1 1/4"	55
1 1/2"	75
2"	90

Table 4-5

INSTALLING FLANGE TERMINATION FITTINGS

- A. **MOUNT FLANGE:** Mount flange to desired location on wall stud or floor using appropriate size screws to provide a firm mount. Figure: 4-10 Do not attach the fitting to the flange at this point. This will be done after the fitting to pipe connection has been completed. Insert pipe through the back of the flange after preparing pipe in accordance with steps 1 thru 3, **making sure to strip jacket to expose FIVE corrugations.**
- B. **PIPE TO FITTING CONNECTION:** Attach fitting to pipe following all instructions in step 5. Figure:4-11 Once the fitting has been tightened to the pipe, slightly loosen this connection until the fitting can be rotated on the pipe. Figure: 4-12 Screw the fitting on to the flange and tighten. Holding the flange fitting nut, re-tighten the body. Figure: 4-13

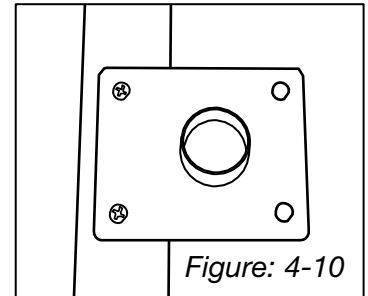

Figure: 4-10

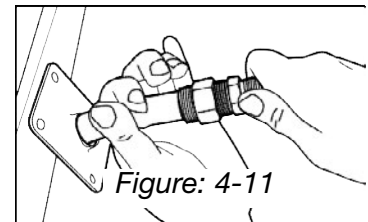

Figure: 4-11

⚠ CAUTION: This step must be followed to avoid excessive twisting of the pipe when tightened.

INSTRUCTIONS FOR RE-USING FITTINGS

If there is a leak in the fitting, the most probable cause is that the pipe was not properly prepared and has a tear or excessive deformation in the last corrugation that interferes with proper sealing. To remove the pipe from the fitting, strip the jacket back behind the fitting nut/ flange about 1". Disassemble the fitting completely, and push pipe through the nut to expose the snap ring. Gently pry the ring off of the pipe, and remove pipe from fitting. Inspect the ring for damage, and replace if necessary. Since the ring has been compressed into the back of the body, it must be re-sized before reusing. This is achieved by carefully spreading the ring open by hand or using small pliers. After opening up the ring, insert into fitting nut.

If it inserts without resistance, it must be opened further. Once the ring has been installed, thread the nut and body back together loosely. Re-cut the tubing and prepare per steps 1 thru 3, and assemble to fitting.

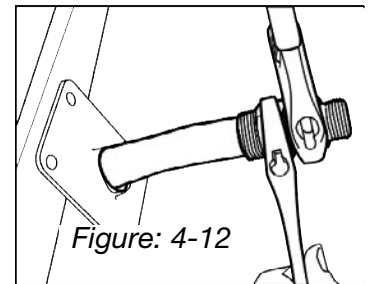

Figure: 4-12

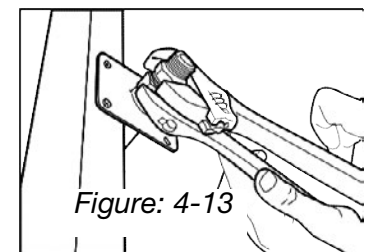

Figure: 4-13

⚠ CAUTION: Knife blade and pipe ends are very sharp. Use care when stripping jacket and handling tubing.

DO NOT USE THREAD SEALANTS WITHIN THE FITTING. USE THREAD SEALANTS ONLY ON THE NPT THREADS



AutoFlare® (Patented) – The Fitting is the Flaring Tool

SECTION 4.2.3 – TROUBLE SHOOTING FITTING CONNECTIONS

1. The tubing cut is the critical step in the fitup procedure. Always cut in a straight section of piping, rather than an area you have bent. Use light roller pressure applied on every revolution to cut tube evenly around its surface. Remember that this tube has a thinner wall than the copper tube you are accustomed to cutting. A sharp blade is very important, and it will be helpful to reserve one cutter for stainless steel only.
2. If the fitting connection cannot be made to seal upon applying torque per the instructions in Section 4.2, continue to tighten an additional quarter to a half turn. If leakage continues, do not continue to apply torque. Disassemble the fitting and inspect the sealing surfaces. The most likely cause of leakage is foreign material on the sealing surfaces. Wipe both fitting and tubing flare with a clean cloth. Inspect the formed flare on the tubing end, which should appear round when compared with the split ring washers and the nut in place. If any deformation is noted, the tubing can be recut and the fitting re-attached. The patented Autoflare fitting has an insert which is self piloting and does not require special tooling to make a leak proof fitting.
3. REASSEMBLY PROCEDURE- When reattaching the AutoFlare fitting, it is only necessary to re-insert the split rings into the space between the first two corrugations and to pull the nut back over the rings into position. The adapter can then be conveniently re-threaded into the nut and torqued as before. If the nut cannot be pulled into place, examine the split-rings, which may have been “coined” by the first torque operation. If this is the case, simply reverse the split-rings positioning to align with the nut and continue the assembly process. If the fitting is reattached more than three times, or if the nut cannot be pulled over the rings in any position, then the split-rings must be replaced. Packets of spare split-rings are available (P/N FGP-RING-SIZE) and the remaining fitting parts can be re-used.

SECTION 4.3 – ROUTING OF TUBING

Depending on local building codes and construction practice, Flexible gas piping can be routed:

1. Beneath floor joists, through floor and ceiling joists, along side of floor and ceiling joists. This is the typical location for residences and commercial buildings with basements and for multi-floor systems. Multiple tubing runs may be bundled.

2. Exterior/interior wall cavities. Hollow interior wall cavities are the preferred location for vertical runs of tubing. Piping runs may be installed in insulated walls. For bat type insulation the piping may be placed within or in front of the insulation facing sheet. Piping restrained by rigid foam type insulation shall be protected along the entire vertical run in accordance with Section 4.4.1.

⚠ CAUTION: Exposed stainless steel that may come in contact with spray foam insulation must be wrapped in self bonding silicone tape in accordance with Section 4.3.2.

3. Through approved conduit under ground or under building slabs. When piping runs are located below grade or under a concrete slab, the **TracPipe® CounterStrike®** shall be routed within a non-metallic water-tight conduit. No tubing joints are permitted within the conduit. Gas piping runs beneath building slabs must be both sleeved and vented as per local codes. See Underground Installations Section 4.9 for underground use of **TracPipe PS-II. TracPipe PS-II** meets code requirements for underground and under building slab installation.
4. Clearance holes for routing the piping through studs, joists, plates etc. shall have a diameter at least 1/2 inch larger than the outside diameter of the piping. When a structural member must be drilled, conformance to building codes must be followed. No structural member shall be seriously weakened or impaired by cutting, notching or otherwise altering the member. Minimum drill hole sizes are listed in Table: 4-6. **TracPipe® CounterStrike®** shall not pass through a bored hole through which any metallic pipe, metallic tube, electrical conductor, electrical or electronic cable or electrical metallic raceway also passes.

Table 4-6

TUBING SIZE	DRILL HOLE SIZE
3/8 inch	1-1/8 inch
1/2 inch	1-3/8 inch
3/4 inch	1-1/2 inch
1 inch	1-3/4 inch
1-1/4 inch	2-1/4 inch
1-1/2 inch	2-1/2 inch
2 inch	3 inch

5. METAL STUDS
For installations involving horizontal runs through galvanized steel studs, use the plastic grommets supplied by the stud manufacturer
6. Care shall be taken to route the tubing in areas that are least susceptible to potential threats wherever possible. Flexible gas piping larger than 1 inch nominal internal diameter installed within hollow cavity walls of 2 x 4 construction shall be protected along the entire concealed length.

SECTION 4.3.1 – CONCEALED LOCATIONS FOR FITTINGS – GENERAL PROVISIONS

The **TracPipe® AutoFlare®** mechanical attachment fittings have been tested and are listed per the requirements of ANSI LC1 and CSA 6.26 Standard (USA and CANADA). This specification provides test requirements which certify fittings for concealed installations and connections to appliances where concealing the fittings is the only practical alternative.

These guidelines address some of the known situations which may require the use of a concealed fitting. While accessibility of fittings may be desirable, there are often situations where concealing the fitting is the only practical option. This guide cannot address all applications of concealed fittings but provides instead typical instructions to demonstrate the principles which apply to fittings, listed for installation in concealed locations.

EXCLUSIONS:

1. Manifold Stations (for 2 PSI systems) which include the multiport manifold, shut off valve, and pressure regulator shall not be installed in concealed locations regardless of the qualifications of tubing fittings.

NEW INSTALLATIONS:

1. CSST may be connected to steel piping systems through threaded pipe connections. This can be a stub-out to an appliance connection or outdoors to a meter, etc.

- Flexible piping connections to fireplace “key valves” can be located in a concealed location, when accessibility is not readily provided. See Figures:4-14 and 4-15

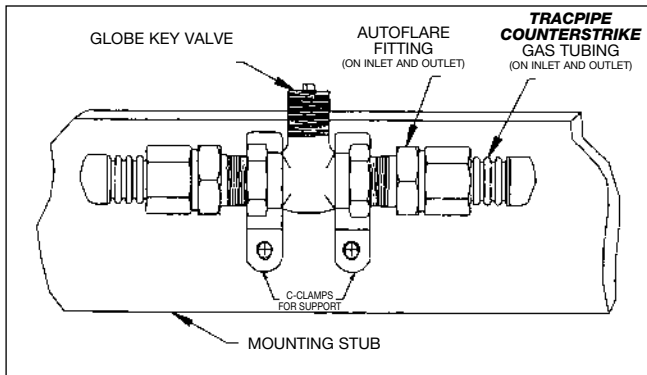

Figure: 4-14

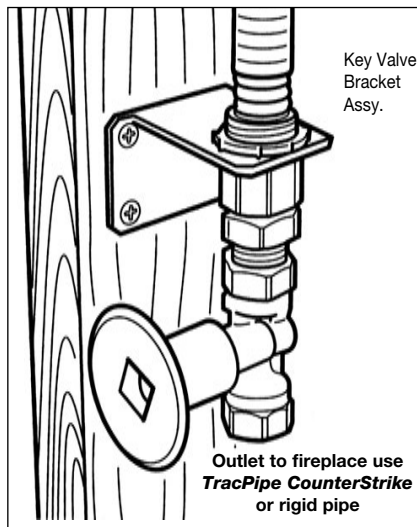

Figure: 4-15

- Multiple gas outlets – when multiple outlets are supplied from a single run of piping, each downstream outlet branch can be connected to the main run using a tee fitting which can be located in a concealed location. Figure: 4-16.

MODIFICATIONS TO INSTALLED SYSTEMS:

- New ceilings in unfinished rooms/basements.**

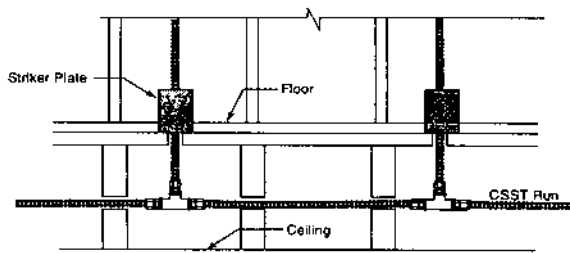

Figure: 4-16 Multiple outlets along main tubing run

Flexible piping fittings originally installed in accessible ceiling locations can be concealed at a later date in the event that a ceiling is installed. Precautions shall be taken to ensure that the newly concealed piping and fittings are adequately protected from accidental puncture in accordance with the instructions in this guideline.

- Extensions to existing tubing runs**-A tubing run can be modified to permit an extension to another appliance location provided there is sufficient capacity to supply both appliances at the same time. If an accessible location for the modification is not available, the existing tubing run can be modified with a tee fitting, resulting in a concealed fitting.
- Repairs to existing tubing runs**-Damaged tubing runs shall be repaired in accordance with instructions in this guide (Section 5.2). The repair can result in a line splice which may ultimately be located in a concealed location.

SECTION 4.3.2 – OUTDOOR INSTALLATION ISSUES

The **TracPipe® CounterStrike®** jacket is resistant to UV and is able to withstand exposure to long periods of sunlight. ANSI/IAS LCI-CSA 6-26 contains test requirements determining suitability for exposure of CSST piping systems to outdoor environments. **TracPipe® CounterStrike®** is certified to this standard and is fully qualified for outdoor installations.

- When installed outdoors, the plastic jacketing shall remain intact as much as practical for the given installation. Any portions of exposed stainless steel shall be wrapped with self bonding silicone tape sealing the fitting connection to prevent later corrosive attack by acid wash or chloride based compounds. Figures: 4-17 and 4-18.
- When **TracPipe® CounterStrike®** is installed in a swimming pool mechanical

room or exposed to a corrosive environment which may be harmful to the tubing, all exposed portions of the stainless steel tubing shall be wrapped with self-bonding tape. Figures: 4-17, 4-18.

- When installed along the side of a structure (between the ground and a height of 6 feet) in an exposed condition, the **TracPipe® CounterStrike®** shall be installed in a location which will not subject the piping to mechanical damage or be protected inside a conduit or protective cover.

NOTICE: For support and protection, **OmegaFlex®** recommends that outside runs along the side of a building shall be clipped securely to the wall or other structural component.

- TracPipe® CounterStrike®** SHALL NOT BE BURIED DIRECTLY IN THE GROUND OR PENETRATE CONCRETE UNLESS IT IS SLEEVED INSIDE OF A NON-METALLIC (PVC) WATER TIGHT CONDUIT or use **TracPipe PS-II**. The conduit shall be sealed at any exposed end to prevent water from entering. See instructions for underground installations Section 4.9.

- When installed underneath mobile homes or in crawl spaces, **TracPipe® CounterStrike®** shall be installed in accordance with these outdoor instructions.

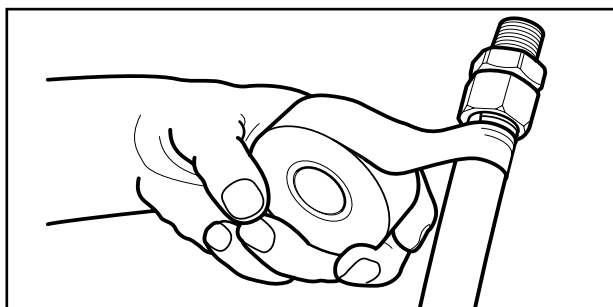

Figure: 4-17-Wrapping with self bonding silicone tape - begin on jacket.

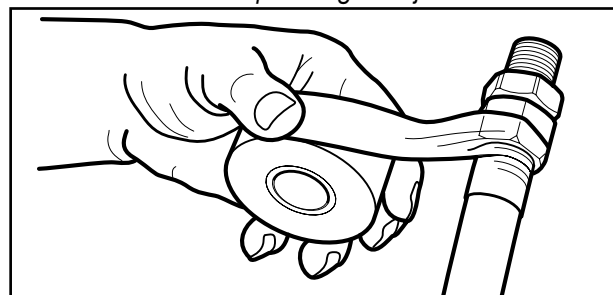

Figure: 4-18 Wrapping with self bonding silicone tape - end on nut.

SECTION 4.4 – PROTECTION

The flexible gas piping must be adequately protected from puncture, shear, crush or other physical damage threats. The tubing shall be protected at points of support and when passing through structural members such as studs, joists and plates in accordance with this section. PROTECTION IS REQUIRED WHENEVER THE TUBING IS CONCEALED, RESTRAINED, AND WITHIN 3 INCHES OF A POTENTIAL THREAT. If the tubing requires protection, the following measures should be taken.

SECTION 4.4.1 – STRIKER PLATE REQUIREMENTS

- Install shielding devices i.e. striker plates to protect the tubing from penetration by drill bits, nails, screws, etc. in those areas where the tubing will be concealed and will not be free to move to avoid such puncture threats.

NOTICE: Only CSA approved hardened striker plates listed for CSST systems may be used.

- At support points and points of penetration less than 2 inches away from any edge of a stud, joist, plate, etc. shielding is required at the area of support and within 5 inches of each side (if appropriate). Use a half striker or a full striker plate in these locations. Figure: 4-19.

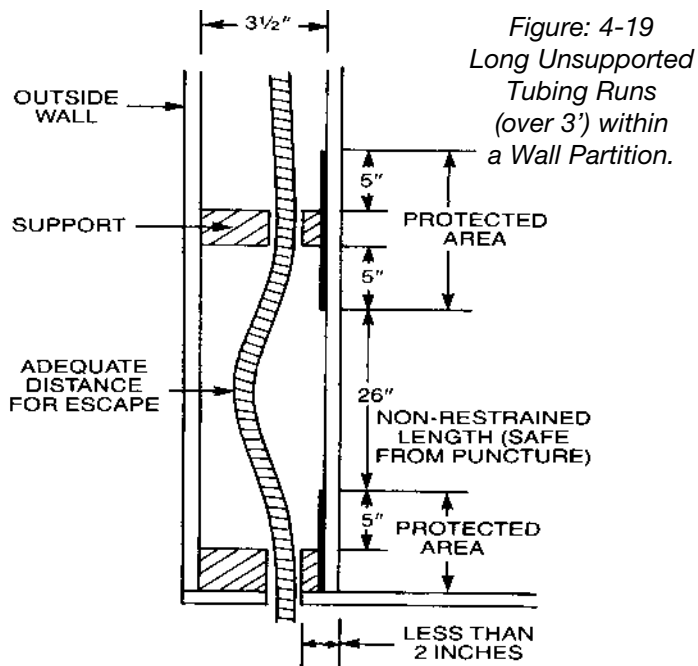

b. At support points and points of penetration 2 to 3 inches from any edge of stud, joist plate, etc. shielding is required throughout area of support. Use a quarter striker plate in these locations. Figure: 4-8.

use include: (but are not limited to) outside walls of buildings with sheathing in place, between floors with enclosed joist areas, and retrofits in existing buildings with walls in place. Steel pipe having an inner diameter at

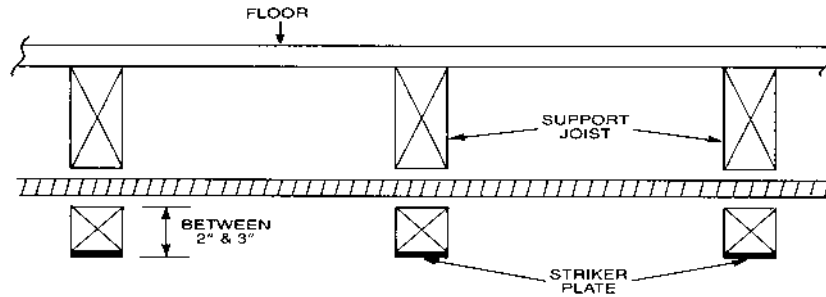

Figure: 4-20
Shielding Requirements at Support Area when Points of Penetration are 2-3 inches from any Edge of a Stud, Joist, Plate, etc.

c. Hardened steel striker plates provide the required protection through building structures as described above. Type RW Floppy steel conduit shall be installed as additional protection at termination points. Figure: 4-21.

least one-half inch larger than the **TracPipe® CounterStrike®** O.D. is approved by CSA International for this use as an alternate to striker plates. Protection must extend 5 inches beyond the penetration of the structural member(s). A 12 inch pipe length is appropriate for penetration of a single stud. OmegaFlex recommends the use of standard striker plates where the building construction permits their installation. See Chart for pipe sizes.

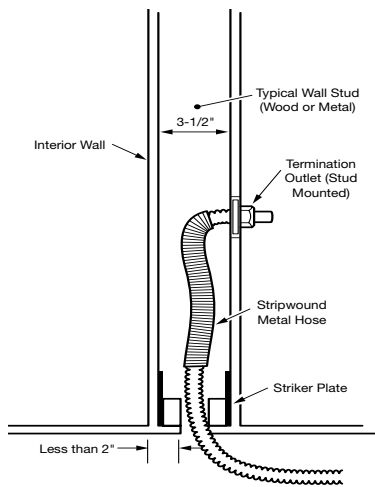

Figure: 4-21

CounterStrike Size	Steel Pipe Size
3/8 inch	1-1/4 inch
1/2 inch	1-1/4 inch
3/4 inch	1-1/2 inch
1 inch	2 inch
1-1/4 inch	2-1/2 inch
1-1/2 inch	2-1/2 inch
2 inch	3-1/2 inch

d. When tubing is routed horizontally between studs, install quarter striker plates at each stud and floppy galvanized steel conduit (spiral metal hose) along the entire length.

2. The best protection is to install the tubing in those out of the way areas where testing has shown no protection is necessary, for example:

e. Schedule 40 steel pipe has been tested by CSA International and found acceptable for puncture protection. Steel pipe can be used where standard striker plates cannot reasonably be installed. Examples of this type of

a. Where the tubing is supported more than 3 inches from any outside edge of a stud, joist, plate, etc. or wall surface. Figure: 4-22.

b. Where any non-restrained tubing can be displaced from the direction of potential penetration.

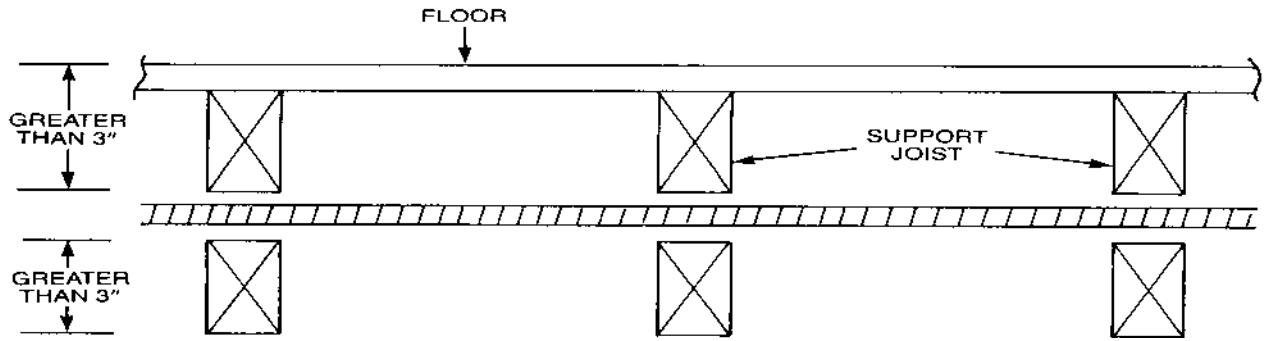

Figure: 4-22

No Shielding Requirement at Support Area when Points of Penetration are greater than 3 inches from any Edge of a Stud, Joist, Plate, etc.

and is not concealed by wallboard or ceilings.
 d. In unfinished garage walls where tubing is exposed.

non-metallic materials. OmegaFlex® recommends either removing the black jacket or transitioning to the CounterStrike® product when passing through areas such as drop ceiling return plenums.

SECTION 4.4.2 – THROUGH WALL PENETRATIONS

1. **TracPipe® CounterStrike®** meets building code requirements (ASTM E84) with respect to flame spread and smoke density. This permits installation in drop ceilings used as return air plenums without jacket removal.
2. For through wall penetration fire stop instructions refer to the UL classification requirements shown in Appendix A. When passing through a fire stop (2 hr. wall) the jacket shall not be removed. Seal between building and **TracPipe® CounterStrike®** with an approved 3M type CP-25 or equivalent caulk.
3. **TracPipe® CounterStrike®** has through wall penetration UL Classifications for 1, 2, 3 and 4 hour requirements depending on materials and type of construction. See Appendix A.

NOTICE: For TracPipe PS-II tubing with black outer jacket, the installer shall address local building codes with respect to flame spread and smoke density regulations for

SECTION 4.5 – METER CONNECTIONS

1. Meters which depend on the service and house piping for support shall not be directly connected to the flexible piping. Instead, use a meter termination fitting or termination mount fitting with steel pipe for the outdoor portion of the connection. For mounting of meters, all fastener locations should be used when installing the flange or mounting plate. Figure: 4-23 and 4-24.

2. Meters which are independently supported with a bracket can be directly connected outdoors with **TracPipe® CounterStrike®** Figure: 4-25. If practical, direct connections shall include a 3 to 6 inch additional length of tubing to accommodate differential settling and meter movement. No mechanical protection of the tubing is required for outdoor connections. **NOTICE:** Prior to installing **TracPipe® CounterStrike®** directly to a meter, ensure that the local utility allows this practice and meter is independently supported as some utilities have regulations specifying meter attachments. Any exposed sections of stainless steel piping must be wrapped with a self-bonding silicone tape. This is especially important with masonry construction. Figure: 4-23–A sleeve is required for **TracPipe® CounterStrike®** penetrations of masonry construction and recommended for wood frame construction.

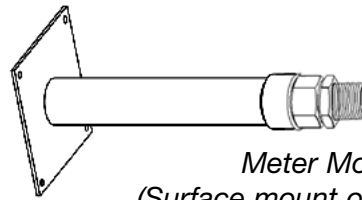

*Meter Mount
(Surface mount on sheathing
or through the rim joist.)*

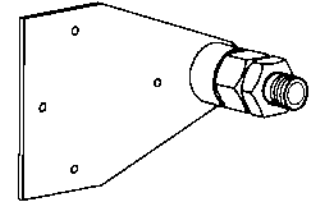

*Termination Mount
(Mount on one stud.)*

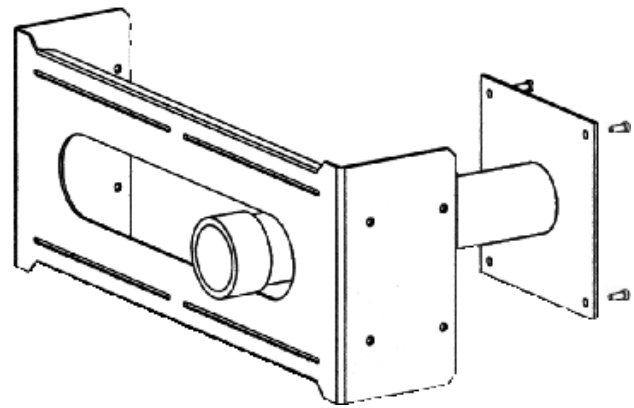

*Stud Bracket
(Mount between two studs.)*

*Figure: 4-24
Meter Mounting Accessories*

Note: Diameter of hole shall be at least 1/2" greater than O.D. of tubing and shall be sleeved and sealed in accordance with local building code (if applicable).

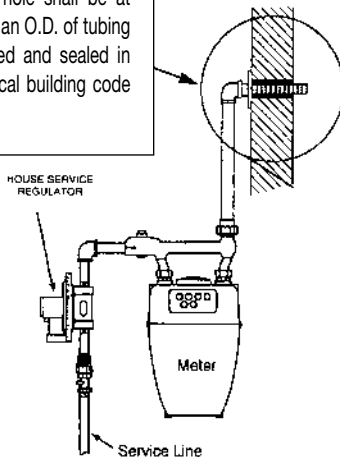

Figure: 4-23

Use a meter termination or a termination mount here

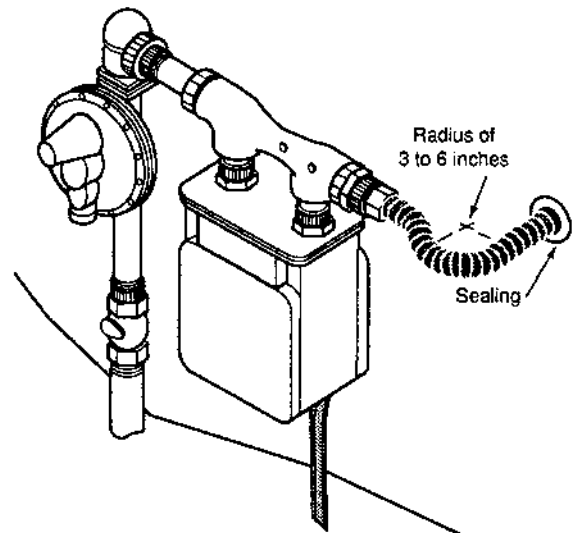

Figure 4-25

SECTION 4.6 — APPLIANCE CONNECTIONS

A listed termination outlet (termination mount, flange fitting, or recessed wall box) are designed to be used at all floor & hollow wall piping outlets used for moveable appliances and quick disconnect devices. The termination outlets are intended to simplify the installation of gas connections for moveable appliances and minimize the need for concealed fittings. The flange fitting or plate shall be securely fastened in place during rough-in. It may be attached to a brace spanning between studs for a wall location, or directly to the floor Figure: 4-26. The flange may also be mounted with a flange L-bracket, which is nailed or screwed to a stud.

As an alternate to using a listed termination outlet for moveable appliances, a rigid termination can be made by transitioning the **TracPipe® CounterStrike®** to rigid black pipe at a suitable location. The rigid pipe stub-out must be secure-

ly fastened to the wall or floor using a pipe flange or other rigid mounting component. Another option is to use a termination mounting bracket fastened to the block wall and make the drop with **TracPipe® CounterStrike®**. Final connection is with a flexible appliance connector.

1. MOVABLE APPLIANCE CONNECTIONS (SUCH AS RANGES AND DRYERS) SHALL BE MADE USING APPROVED FLEXIBLE APPLIANCE CONNECTORS. Figure: 4- 27. See also recessed wall box Section 4.6.1.
2. FIXED APPLIANCE CONNECTIONS MAY BE DIRECTLY CONNECTED TO THE FLEXIBLE GAS PIPING SYSTEMS (in most jurisdictions). When the fixed appliance is located in a secure, dedicated space, such as a basement, attic, garage or utility closet, the flexible piping may be directly connected to the appliance shut-off valve without installation of a flange fitting or flexible appliance connector.

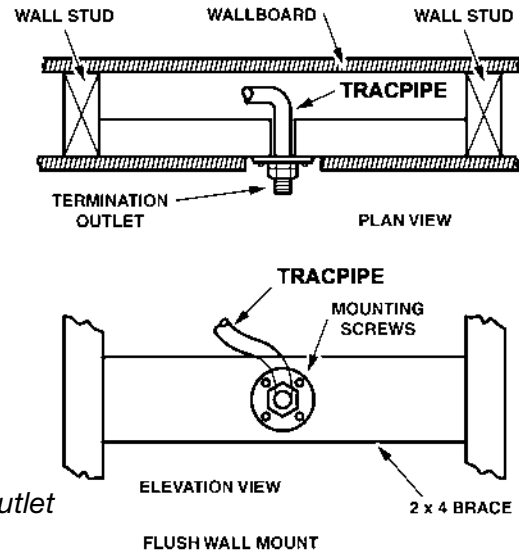
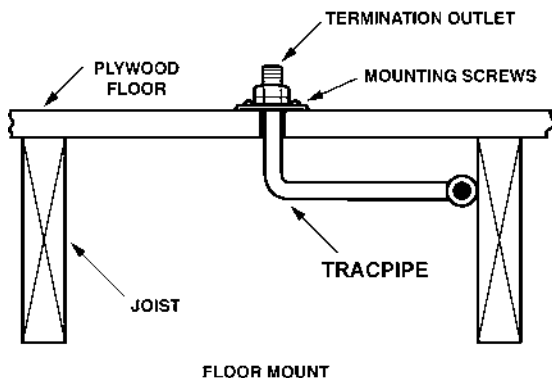

Figure: 4-26
Support Device Flange Termination Outlet

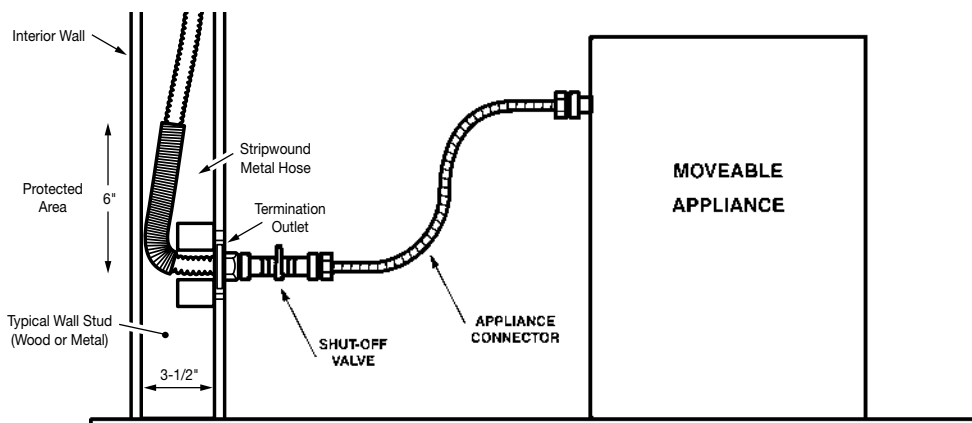

Figure: 4-27
Stainless Steel Gas Connector Connection to a Movable Gas Appliance

SECTION 4.6.1 — RECESSED WALL BOX

NOTICE: This **TracPipe® CounterStrike®** Gas Outlet Box has been tested and approved for 1 and 2 hr Fire Stop Systems in accordance with UL 1479. It installs with zero clearance for a finished appearance in laundry rooms, kitchens and mechanical rooms, and provides a rigid attachment point for appliance connectors serving movable appliances. This box is not suitable for use with black iron pipe or any CSST brand other than **TracPipe® CounterStrike®**.

Wall Box Installation Instructions

1. Remove knockout for appropriate size valve. The 3/8 inch and 1/2 inch size use the small knockout and the 3/4 inch size uses the large knockout. Install **TracPipe® CounterStrike®** gas piping and cut to desired length using a standard tubing cutter with a sharp wheel. Strip jacket back approx. 2 inch. Inspect pipe for a clean cut without tears.

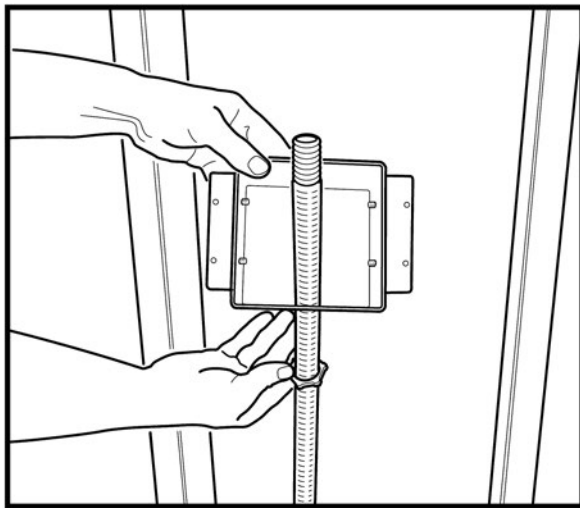
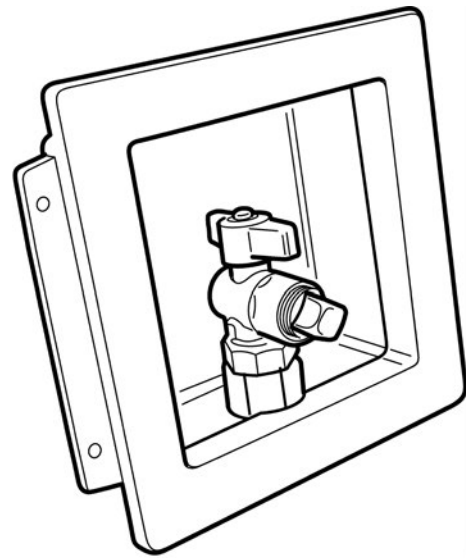

Figure: 4-28

2. Remove box cover and slip locknut and box over end of pipe. Figure: 4-28

NOTICE: Mounting tabs are oriented for a single layer of drywall. When two layers are used for some 2-HR rated walls, remove screws on tabs and invert mounting tabs.



CAUTION: FGP-WBTM is fire rated to UL 1479. This box has been designed for use with **TracPipe® CounterStrike® Flexible** Gas Piping as an appliance termination and is not suitable for connection to any other CSST brand or black iron pipe. Installers must be trained on **TracPipe® CounterStrike®** before installing this product.

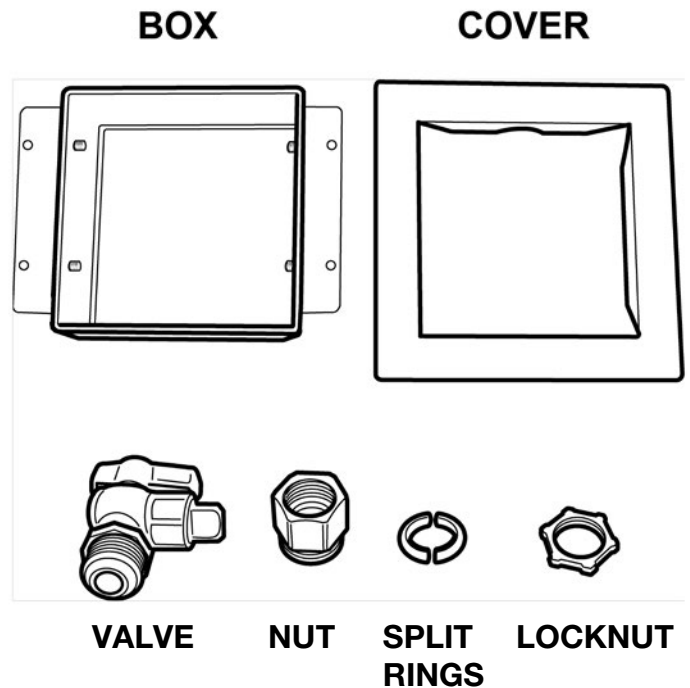

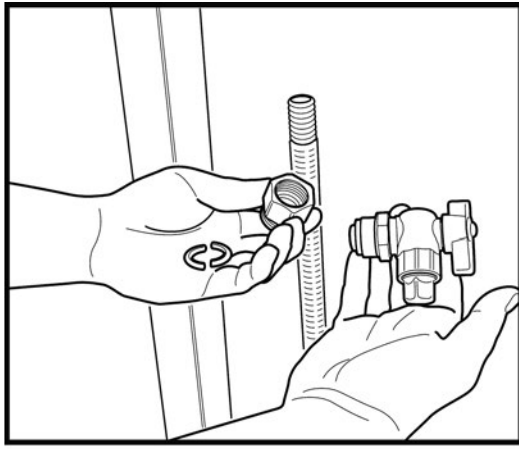

Figure: 4-29

3. Disassemble nut and split rings from valve. Figure: 4-29

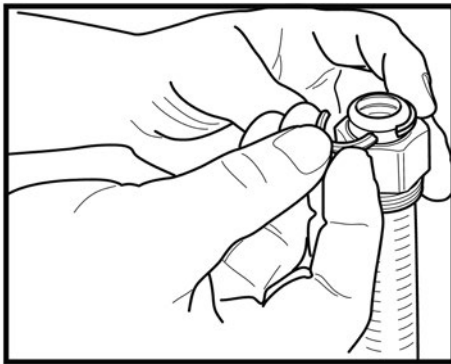

Figure: 4-30

4. Slip nut over end of pipe and insert split rings into valley of the first corrugation. Figure: 4-30

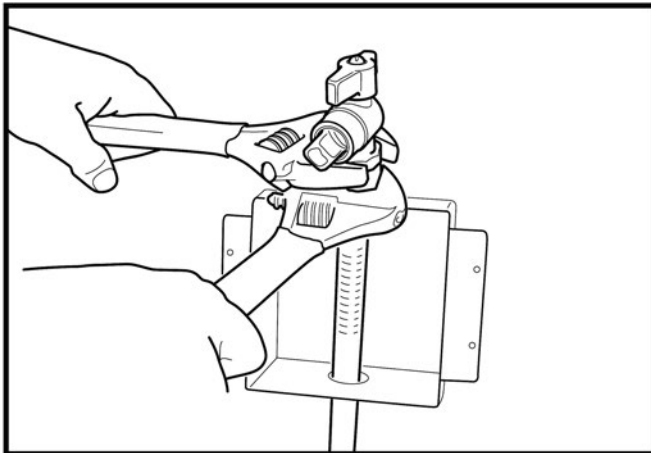

Figure: 4-31

5. Thread 90 degree ball valve onto nut and tighten so valve outlet faces forward. It is recommended that crescent wrenches be used to avoid damaging valve or nut. Figure: 4-31 **Do not use thread sealants on this connection.**

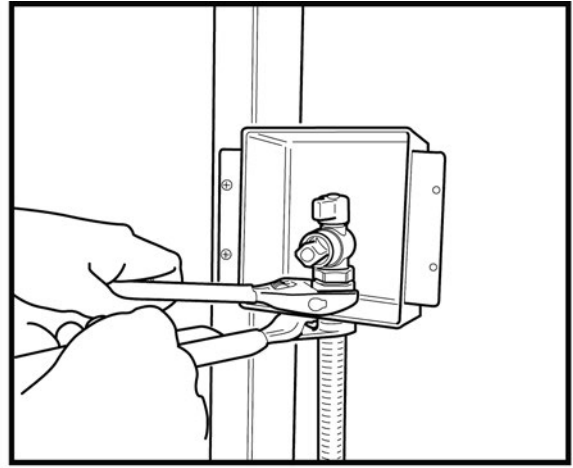

Figure: 4-32

6. Slide box up and over the threads on the bottom of the nut and mount box firmly to stud. Provide full support by fastening both mounting tabs to structure where required by local codes.
7. Secure valve assembly to box with lock-nut. Figure: 4-32

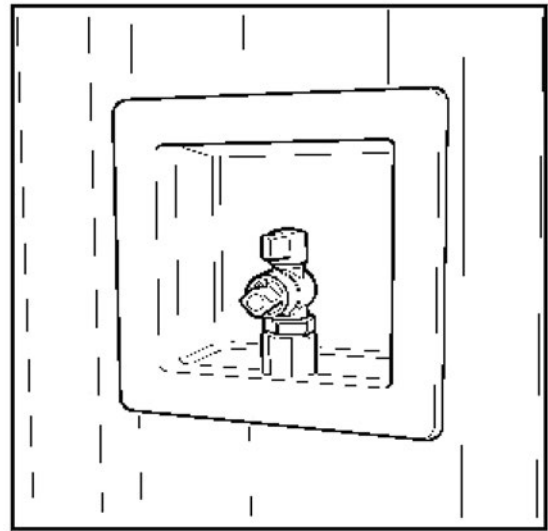

Figure: 4-33

8. Install box cover after completion of dry-wall. If the gap between the edges of the box and the drywall is less than 1/4", no fire caulking is required. Figure: 4-33

NOTICE: These instructions must be used in conjunction with the **TracPipe® CounterStrike®** Design and Installation Guide. **TracPipe® CounterStrike®** flexible gas piping material must only be installed by a qualified person who has been trained through the **TracPipe® CounterStrike®** Gas Piping Installation Program.

SECTION 4.6.2 – PAD MOUNTED EQUIPMENT, ROOF TOP EQUIPMENT

1. Gas equipment mounted on concrete pads or blocks such as L.P. tanks, gas air conditioners, heat pumps, pool heaters, NGV refueling stations and gas generators, may be connected to the **TracPipe® CounterStrike®** system at a termination fitting using either rigid pipe or an approved outdoor appliance connector. Direct connection of **TracPipe® CounterStrike®** to pad mounted equipment is permitted when the CSST is securely supported and located where it will be protected from physical damage. Follow local and state codes. Any portions

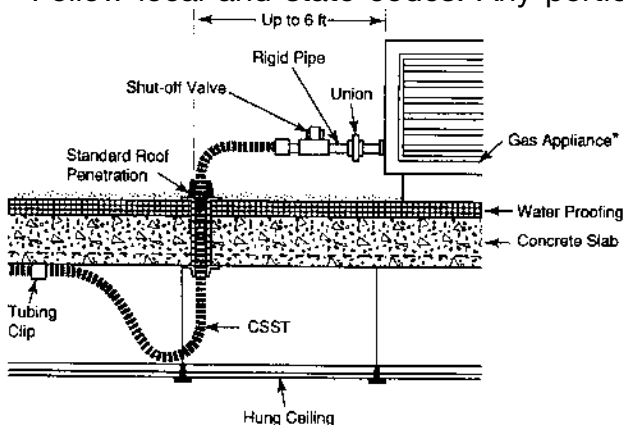
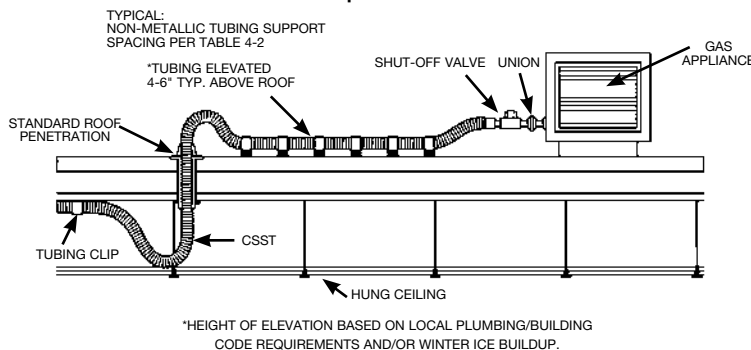

Figure: 4-34 Short (1-6 foot) outdoor connection to roof mounted equipment

of exposed stainless steel shall be wrapped with self bonding silicone tape sealing the fitting connection. Figures: 4-17 and 4-18. When the appliance is mounted on vibration isolations pads the **TracPipe® CounterStrike®** shall be terminated with a listed termination fitting and the appliance shall be connected to the gas piping system with a listed appliance connector.

2. No special mechanical protection of the piping is required for connection to roof top

Figure: 4-35



equipment. Whenever possible, roof penetrations shall be located within 6 feet of the equipment to be connected as shown in Figure: 4-34. Long runs of tubing shall be supported with non-metallic blocks at the support interval listed in Table: 4-2, and raised above the roof a distance determined by local code/practice. Figure: 4-35. The blocks are to be attached to the roof surface in accordance with the roofing manufacturer's instructions.

3. **TracPipe® CounterStrike®** may be supported with strut/channel running from block to block beneath the flexible gas pipe. Galvanized shallow channel (13/16 inch) with splice plates at joints and bends provides a secure, damage resistant "track". With metallic strut support, blocks can be reduced to every 8 feet. The **TracPipe® CounterStrike®** should be firmly attached to each block with metallic clamps designed for the strut or appropriate fastening mechanism. Figure: 4-36. Black cable ties (UV resistant) at intermediate points facilitate rolling out the **TracPipe® CounterStrike®**.

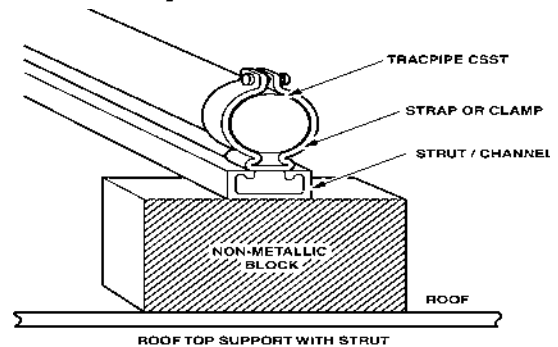

Figure: 4-36

4. Piping run vertically up the side of the building shall be protected in accordance with the Section 4.3.2 Outdoor Installation Issues.

SECTION 4.6.3 – OUTDOOR APPLIANCES – BARBEQUE GRILL AND GAS LIGHT CONNECTIONS

1. Movable grills shall be connected using an approved outdoor appliance connector which shall be attached to the flexible piping system at either a termination mount fitting, a transition to a steel nipple, or a quick connect device such as the M. B. Sturgis Model 3/375 shown in Figure: 4-37: The quick-connect outlet shall be installed in accordance with manufacturer’s instructions.
2. Permanently mounted grills located on decks shall be connected with the **TracPipe® CounterStrike®** system as shown in Figure: 4-38—and in accordance with this guide. The outdoor portion of the piping shall be supported against the side of any of the inside deck joists. If the elevation of the deck is below the top of the foundation, any exposed piping shall be protected using water-tight non-metallic conduit.

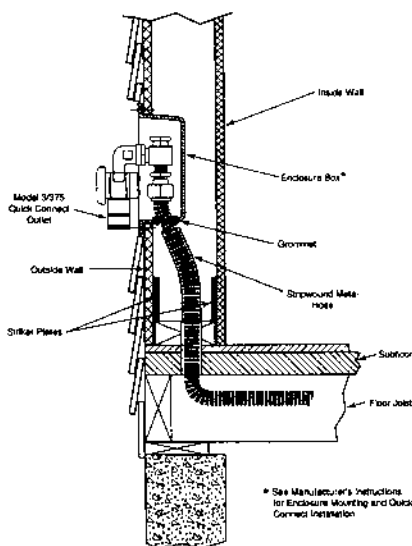

Figure: 4-37

3. Permanently mounted lights located on decks shall be connected to the piping system the same as permanently mounted grills shown in Figure: 4-38 and in accordance with the manufacturer’s instructions.

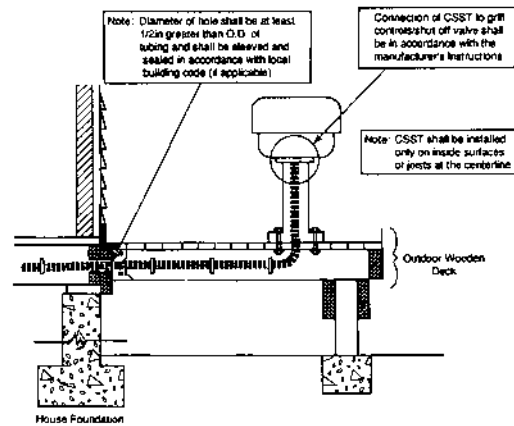

Figure: 4-38

4. Yard mounted lights shall be connected to the **TracPipe® CounterStrike®** system as shown in Figure: 4-39: All piping installed below grade shall be protected by non-metallic, water-tight conduit or **TracPipe PS-II** for underground use. Exposed ends of the conduit shall be sealed against water entry.

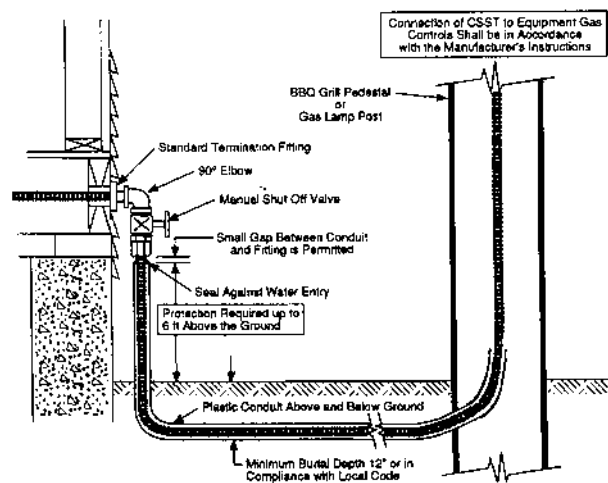

Figure: 4-39

Section 4.6.4— FIREPLACE INSTALLATIONS

1. **TracPipe® CounterStrike®** shall not be directly routed into a metallic gas appliance enclosure utilizing a metallic vent which penetrates a roofline. The **TracPipe® CounterStrike®** connection shall be made outside of the metallic gas appliance enclosure to a segment of rigid metallic pipe, a stub-out or a termination fitting (Figure 4-40).
2. **TracPipe® CounterStrike®** may be used to deliver gas directly to the control valve for approved unvented appliances, heat generating fireplaces with side-wall venting, gas logs used in masonry fireplaces, and pre-fabricated fireplace inserts with non-metallic venting.
3. **TracPipe® CounterStrike®** connections to approved unvented appliances and sidewall vented fireplaces may be made to the shut-off valve located in the control area beneath the burner unit without removal of the polyethylene jacket. When connecting to decorative gas logs the jacket shall be removed inside the fire box. Stainless steel melting temperatures (2000o F) are consistent with black iron.

CAUTION: For gas log lighter installations in all-fuel fireplaces, the **TracPipe® CounterStrike®** run MUST be terminated at the key valve or another location outside the fireplace.

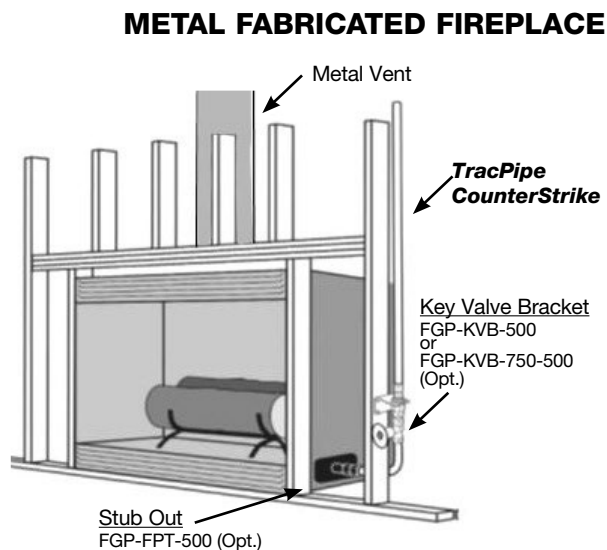

Figure: 4-40

4. When it is permitted (see Item 1) to install **TracPipe® CounterStrike®** through sheet metal enclosures, such as those commonly used in decorative gas fireplaces, the manufacturer's recommendation is to leave the protective polyethylene jacket in place through the sheet metal penetration. The **TracPipe® CounterStrike®** should be clipped to the building structure at a suitable location outside the fireplace to limit the amount of motion after installation. If additional protection is required, a short piece of floppy conduit or PVC pipe may be used between the jacket and the enclosure.
5. In masonry fireplace installations of decorative gas appliances (log sets) it is recommended to leave the polyethylene jacket in place throughout the masonry penetration providing a non-metallic sleeve for the flexible stainless steel. Caulking can then take place between the jacket and the penetration at interior and/or exterior locations. Remove the jacket inside the firebox. If additional protection is required, the **TracPipe® CounterStrike®** may be sleeved using PVC pipe in addition to the included jacket.
6. The FGP-FPT may be used in all applications where it is desirable not to penetrate the enclosure with tubing. Figure: 4-41.

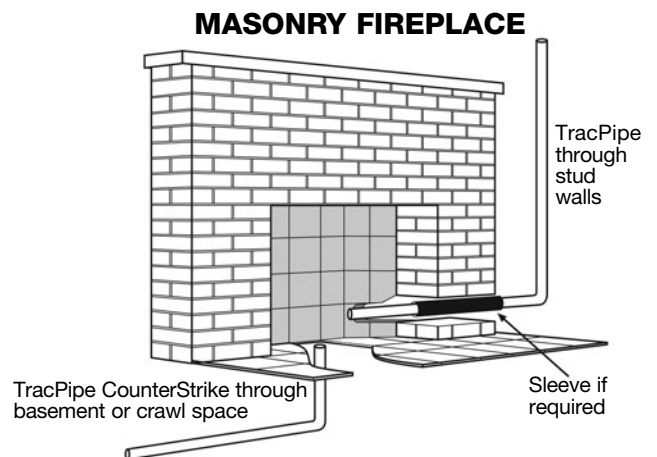

Figure: 4-41

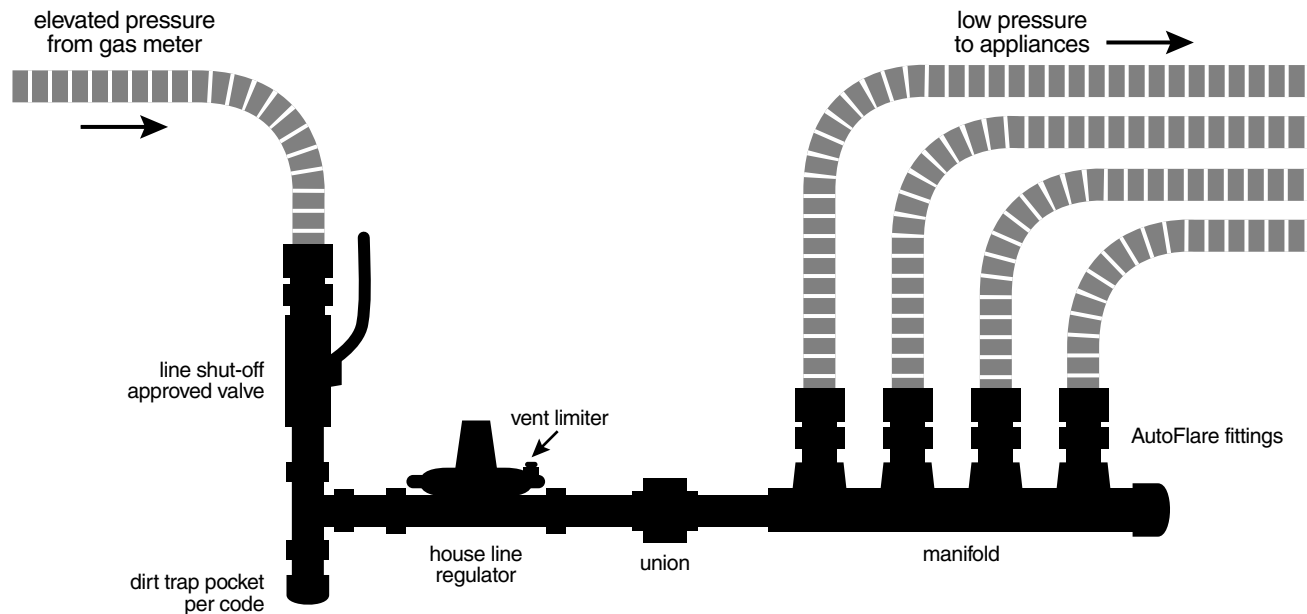

Figure: 4-42

SECTION 4.7 – MANIFOLD & REGULATOR STATION

The use of a central manifold and regulator station is recommended for elevated pressure systems which are typically installed in a parallel arrangement to take advantage of the capacity of the regulator. Figure: 4-42. Manifolds are available with the **TracPipe® CounterStrike®** system, or the use of black iron pipe and tee fabricated manifolds is permitted with this system. The manifold/regulator station should be located nearby the largest gas consuming appliances, typically the furnace or boiler and the water heater in order to allow short runs to these units.

The manifold station **MUST** be located in an accessible location because of the shut-off valve(s) and regulator it contains. The manifold station may be contained in an enclosure box called a gas load center. Figure: 4-43. Optional gas shut-off valves may be mounted on the manifold for each appliance run.

Manifolds installed on low pressure systems or in locations removed from the regulator may be concealed.

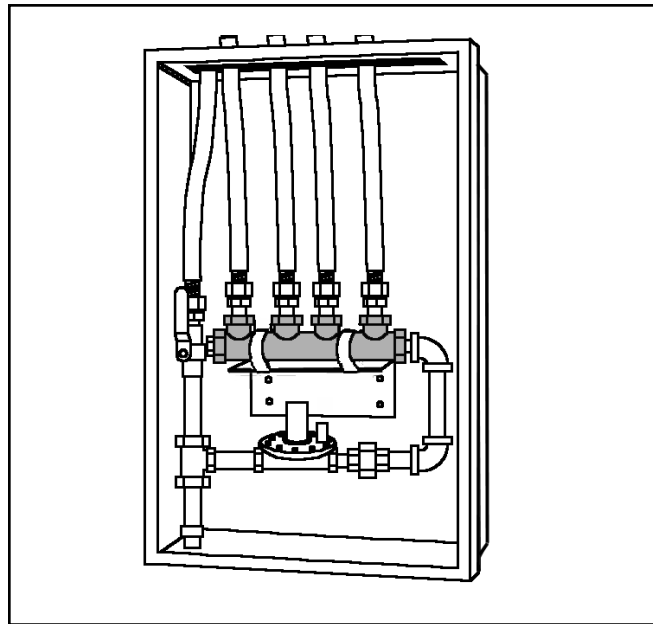

Gas Load Center

Figure: 4-43

SECTION 4.8 – REGULATORS AND ELEVATED PRESSURE SYSTEMS

A tubing system used at gas pressures exceeding 1/2 PSI but serving appliances rated for 1/2 PSI maximum, shall contain a pounds-to-inches regulator to limit the downstream pressure to no more than 1/2 PSI. Gas pressure regulators shall comply with a nationally recognized standard for pressure regulators.

Regulators used to reduce elevated system pressures for use by appliances must also conform to the following:

1. Must be sized to supply the required appliance load. Section 4.8.2
2. Must be equipped with an acceptable vent limiting device, supplied by the manufacturer, or be capable of being vented to the outdoors. **OmegaFlex**[®] ships all regulators with vent-limiters installed.
3. Must be installed in accordance with manufacturers instructions. When a vent-limiter is used the regulator must be mounted in an upright position. Install the regulator properly with gas flowing as indicated by the arrow on the casting.
4. Must be installed in a fully accessible area with an approved shut off valve ahead of regulator. A union will enable removal of the regulator if the location does not otherwise permit removal for servicing. The ability of the **TracPipe**[®] **AutoFlare**[®] or **AutoSnap**[®] fitting to allow disassembly and reattachment provides for regulator removal in most instances.
5. Line regulators do not vent gas under normal operating conditions. Any regulator found to be venting gas should be replaced immediately. Vent-limiters are required to limit venting in the event of a diaphragm failure, within the regulator, to limits identical to those imposed on a gas appliance control valve.

6. For outdoor installations remove the vent limiter and mount regulator with the vent outlet pointing down to prevent the entrance of water. A plastic cap FGP-CAP-3 is available, for outdoor installations permitting the regulator to be mounted in an upright position, for some regulator models.

SECTION 4.8.1 REGULATOR ADJUSTMENTS

1. Regulators can be adjusted to deliver different outlet pressures within a limited range. The range is determined by the spring installed.
2. Adjustment can be accomplished by first removing the regulator seal cap to expose the adjusting screw. Turning the screw clockwise will increase outlet pressure, turning it counter-clockwise will decrease pressure.

 **CAUTION:** For outdoor venting, the line must be at least the same size as the regulator vent connection, and cannot exceed a length of 30 feet. The vent shall be designed to prevent entry of water, insects or other foreign materials that could cause blockage of the line. DO NOT VENT TO APPLIANCE FLUE OR BUILDING EXHAUST SYSTEM. DO NOT VENT TO PILOT LIGHT.

3. If spring adjustment will not produce desired outlet pressure, check to make sure supply pressure is at least equal to desired outlet pressure plus pressure drop of the regulator. If supply pressure is adequate, consult factory if adjustment still can not be made. Do not continue to turn regulator adjusting

screw clockwise if outlet pressure readings do not continue to increase. THIS MAY RESULT IN OVER-FIRING DUE TO LOSS OF PRESSURE CONTROL, SHOULD THERE BE A SUBSEQUENT INCREASE IN INLET PRESSURE.

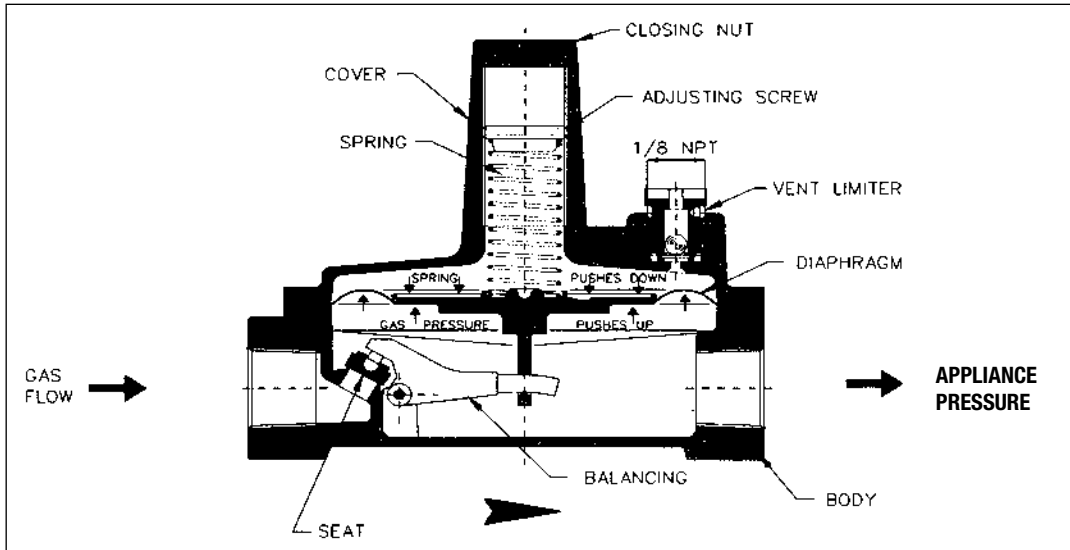

SECTION 4.8.2 REGULATOR SUPPLY PRESSURE AND CAPACITIES DROP FOR SINGLE AND MULTIPLE APPLIANCES

NATURAL GAS 0.64 SPECIFIC GRAVITY

REGULATOR CAPACITIES expressed in CFH (m³/h) 0.64 Specific Gravity Gas

Regulator Application	Part Number	NPT SIZE	Maximum Single Appliance Load	Outlet Pressure Set Point	Operating Inlet Pressure			
					1/2 psi (34 mbar)	3/4 psi (52 mbar)	**1 psi (69 mbar)	***1-1/2 psi (103 mbar)
2 psig	FGP-REG-3	1/2"	140 (4.0)	8" w.c.	145 (4.1)	200 (5.7)	250 (7.1)	250 (7.1)
2 psig	FGP-REG-3P	1/2"	140 (4.0)	11" w.c.	93 (2.6)	172 (4.9)	225 (6.4)	250 (7.1)
2 psig	FGP-REG-5A	3/4"	300 (8.5)	8" w.c.	335 (9.5)	475 (13.5)	550 (15.6)	550 (15.6)
2 psig	FGP-REG-5P	3/4"	300 (8.5)	11" w.c.	211 (6.0)	391 (11.1)	511 (14.5)	550 (15.6)
2 psig	FGP-REG-7L	1"	900 (25.5)	8" w.c.	690 (19.5)	970 (27.5)	1000 (28.3)	1000 (28.3)
2 psig	FGP-REG-7L	1"	900 (25.5)	*11" w.c.	441 (12.5)	816 (23.1)	1000 (28.3)	1000 (28.3)

5 psig w/ OPD	FGP-REG-3L47	1/2"	125 (3.5)	8" w.c.	125 (3.5)	125 (3.5)	125 (3.5)	125 (3.5)
5 psig w/ OPD	FGP-REG-3L47	1/2"	125 (3.5)	*11" w.c.	105 (3.0)	125 (3.5)	125 (3.5)	125 (3.5)
5 psig w/ OPD	FGP-REG-3L48	1/2"	200 (5.7)	8" w.c.	160 (4.5)	200 (5.7)	200 (5.7)	200 (5.7)
5 psig w/ OPD	FGP-REG-3L48	1/2"	200 (5.7)	*11" w.c.	120 (3.4)	200 (5.7)	200 (5.7)	200 (5.7)
5 psig w/ OPD	FGP-REG-5AL48	3/4"	320 (9.1)	8" w.c.	320 (9.1)	320 (9.1)	320 (9.1)	320 (9.1)
5 psig w/ OPD	FGP-REG-5AL48	3/4"	320 (9.1)	*11" w.c.	245 (6.9)	320 (9.1)	320 (9.1)	320 (9.1)
5 psig w/ OPD	FGP-REG-5AL600	3/4"	425 (12.0)	8" w.c.	345 (9.8)	425 (12.0)	425 (12.0)	425 (12.0)
5 psig w/ OPD	FGP-REG-5AL600	3/4"	425 (12.0)	*11" w.c.	260 (7.3)	425 (12.0)	425 (12.0)	425 (12.0)
5 psig w/ OPD	FGP-REG-5AL601	1"	465 (13.2)	8" w.c.	375 (10.6)	465 (13.2)	465 (13.2)	465 (13.2)
5 psig w/ OPD	FGP-REG-5AL601	1"	465 (13.2)	*11" w.c.	285 (8.1)	465 (13.2)	465 (13.2)	465 (13.2)

* Requires manual field adjustment of regulator to obtain 11" w.c. outlet pressure

** Recommended sizing column for 2 psig Natural Gas TracPipe CounterStrike installations refer to Table N-5 Section 7.0.

*** Recommended sizing column for 5 psig Natural Gas TracPipe CounterStrike installations refer to Table N-6 Section 7.0.

PROPANE 1.53 SPECIFIC GRAVITY

REGULATOR CAPACITIES expressed in CFH (m3/h) 1.53 Specific Gravity Gas

(MBTUh values based on Gas with a heating value of 2520 BTU per cubic foot)

Regulator Application	Part Number	NPT SIZE	Maximum Single Appliance Load	Outlet Pressure Set Point	Operating Inlet Pressure			
					1/2 psi (34 mbar)	3/4 psi (52 mbar)	**1 psi (69 mbar)	1-1/2 psi (103 mbar)
2 psig	FGP-REG-3P	1/2"	91 (2.6) [229 MBTUh]	11" w.c.	60 (1.7) [152 MBTUh]	112 (3.2) [281 MBTUh]	146 (4.1) [368 MBTUh]	162 (4.6) [409 MBTUh]
2 psig	FGP-REG-5P	3/4"	195 (5.5) [491 MBTUh]	11" w.c.	137 (3.9) [345 MBTUh]	254 (7.2) [639 MBTUh]	332 (9.4) [836 MBTUh]	357 (10.1) [899 MBTUh]
2 psig	FGP-REG-7L	1"	584 (16.5) [1472 MBTUh]	*11" w.c.	286 (8.1) [721 MBTUh]	529 (15.0) [1334 MBTUh]	649 (18.4) [1635 MBTUh]	649 (18.4) [1635 MBTUh]

* Requires manual field adjustment of regulator to obtain 11" w.c. outlet pressure

** Recommended sizing column for 2 psig Propane TracPipe CounterStrike installations refer to Table P-3 Section 7.0.

CONSULT THE REGULATOR MANUFACTURER FOR ADDITIONAL CAPACITY & PRESSURE DROP INFORMATION.

SECTION 4.8.3 – OVER-PRESSURE PROTECTION

At supply pressures in excess of 2-PSI the ANSI Z21.80 line regulator standard requires a means - (an over-pressure protection device (OPD) approved and tested with the regulator) to limit the downstream pressure to 2-PSI maximum, in the event of regulator failure.

To comply with the ANSI Standard and with all codes adopted in the US and Canada, all installations exceeding 2-PSI (primarily 5-PSI systems, but including all other elevated pressure installations higher than 2-PSI nominal) require a tested and approved over-pressure protection device for use with the pounds to inches regulator. This requirement applies to line regulators but not to appliance regulators.

Regulators for 5 PSI systems must be shipped as an assembled unit from the factory, regulator with OPD attached. Consult the current **TracPipe® CounterStrike®** Price List for information regarding part numbers and capacity.

NOTICE: For systems operating above 5-PSI or incorporating regulators approved to a standard other than ANSI Z21.80 consult your local code authority regarding over-pressure protection requirements.

SECTION 4.9 – UNDERGROUND INSTALLATIONS

1. CODE REQUIREMENTS

When gas piping runs are located below grade in contact with earth or other material that could corrode the piping, codes require that the gas piping shall be protected against corrosion.

When piping is installed underground beneath buildings, codes require that the piping shall be encased in a conduit and be vented in accordance with the code. Table: 4-7. The conduit shall be designed to withstand the superimposed loads. **NO FITTINGS OR COUPLINGS ARE PERMITTED BENEATH BUILDINGS.**

Table: 4-7

CounterStrike Size	Min. Conduit Size
3/8 inch	1-1/4 inch
1/2 inch	1-1/4 inch
3/4 inch	1-1/2 inch
1 inch	2 inch
1-1/4 inch	2-1/2 inch
1-1/2 inch	2-1/2 inch
2 inch	3-1/2 inch

Larger Conduit may be required to accommodate any bends in the piping.

2. MODEL CODES

TracPipe® PS-II (patented) installations conform to the underground fuel gas installation requirements of:

The National Fuel Gas Code NFPA 54

The International Fuel Gas Code

The Uniform Plumbing Code UPC®

The LP Gas Code NFPA 58

SECTION 4.9.1 – GUIDELINES FOR UNDERGROUND INSTALLATIONS

1. Lay **TracPipe® PS-II** in a trench. Install the gas piping with a substantially continuous bearing on the bottom of the trench, to the appropriate burial depth as defined in Table: 4-8 and shown in Figure: 4-44.

⚠ CAUTION: TracPipe® PS-II systems must only be installed by a qualified person who has been trained through the TracPipe® CounterStrike® Gas Piping Installation Program. All installations must comply with local code requirements and the instructions contained in the TracPipe® CounterStrike® Design and Installation Guide.

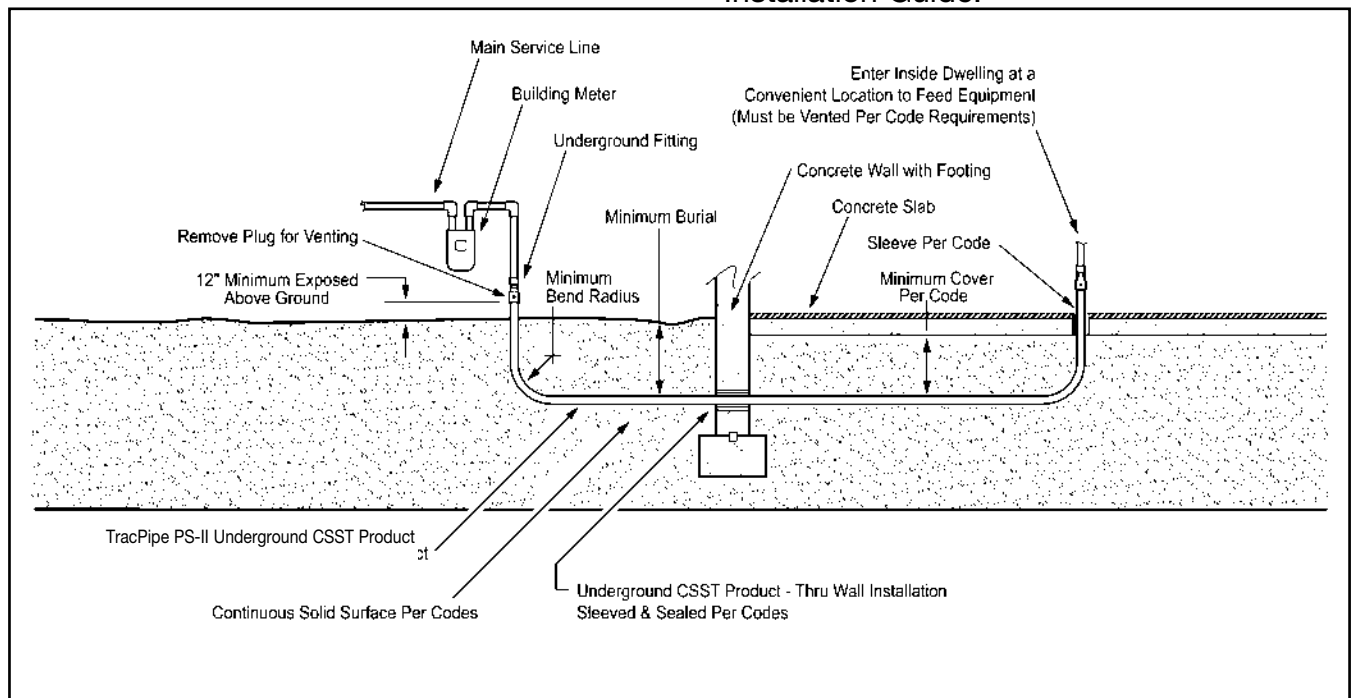

Figure: 4-44

Table: 4-8

Minimum cover requirements for **TracPipe**® PS-II, Burial in inches (cover is defined as the shortest distance measured between a point on top surface of the outer sleeve and the top surface of finished grade, concrete or similar cover)

Location of buried TracPipe® PS-II	Minimum cover for direct burial without concrete encasement
All locations not specified below	18 inch
In trench below 2-in thick concrete or equivalent	12 inch
Under a building with interior slab	4 inch
Under minimum of 4-in. thick concrete exterior slab with no vehicular traffic and the slab extending not less than 6-in beyond the underground installation	4 inch
Under streets, highways, roads, alleys, driveways, and parking lots	24 inch
One and two family dwelling driveways and parking lots and used only for dwelling-related purposes	18 inch
In or under airport runways, including adjacent areas where trespassing prohibited	18 inch

Note: When encased in concrete, the concrete envelope shall not be less than 2 inches thick.

- When transitioning **TracPipe**® **PS-II** from below grade or under slab to above grade, use the recommended minimum bend radius as shown in Table: 4-9.

TABLE: 4-9

RECOMMENDED MINIMUM BENDING RADIUS FOR TracPipe ® PS-II	
Tubing Size	Minimum Bend Radius R
	PS-II
3/8 inch	6 inch
1/2 inch	6 inch
3/4 inch	8 inch
1 inch	10 inch
1-1/4 inch	12 inch
1-1/2 inch	16 inch
2 inch	18 inch

- Recommended exposed clearance height (height to the **TracPipe**® **AutoFlare**® fitting above grade) is 12 inches when terminating at this point. For vertical runs up the outside of a building in traffic areas, protect the **TracPipe**® **PS-II** as explained in Section 4.3.2.
- Avoid bending the above grade vertical portion of the **TracPipe**® **PS-II** piping beyond the minimum bend radius in Table:

4-9. To make a tighter bend in order to line up for a wall penetration, use a rigid fitting such as a malleable iron elbow.

- TracPipe**® **PS-II** is suitable for above ground installations and is resistant to U.V. exposure. Portions rising above grade should be rigidly supported by direct attachment to a wall or independent support, (e.g. metallic strut) or by connection to rigid downstream piping or fittings (e.g. at a meter or propane second stage regulator).
- When installing **TracPipe**® **PS-II** underground through a foundation, the space between the outer jacket and the building shall be sealed to prevent entry of gas or water.
- TracPipe**® **PS-II** can penetrate directly through a concrete slab unless other requirements are established by local codes concerning slab penetrations and firestop requirements.
- TracPipe**® **PS-II** can be transitioned to standard **TracPipe**® **CounterStrike**® piping above grade using **TracPipe**® **CounterStrike**® **AutoFlare**® fittings with a **TracPipe**® **PS-II** Coupling P/N FGP-UGC-SIZE. Remove the black plastic vent coupling on the standard **TracPipe**® **CounterStrike**® side.

Alternatively use a malleable iron coupling for the transition.

9. **TracPipe® PS-II** must be transitioned above ground to standard **TracPipe® CounterStrike®** when routing through plenums or through firestop penetrations. The black **TracPipe® PS-II** sleeve is not qualified for these locations.
10. Venting of **TracPipe® PS-II** shall be in accordance with local codes to prevent

the entrance of water, insects or foreign materials.

11. Typical underground installations for corrugated stainless steel tubing include, but are not limited to:
 - Pool and spa heaters
 - School science laboratories
 - Gas service to outbuildings
 - Gas lamp posts and grills



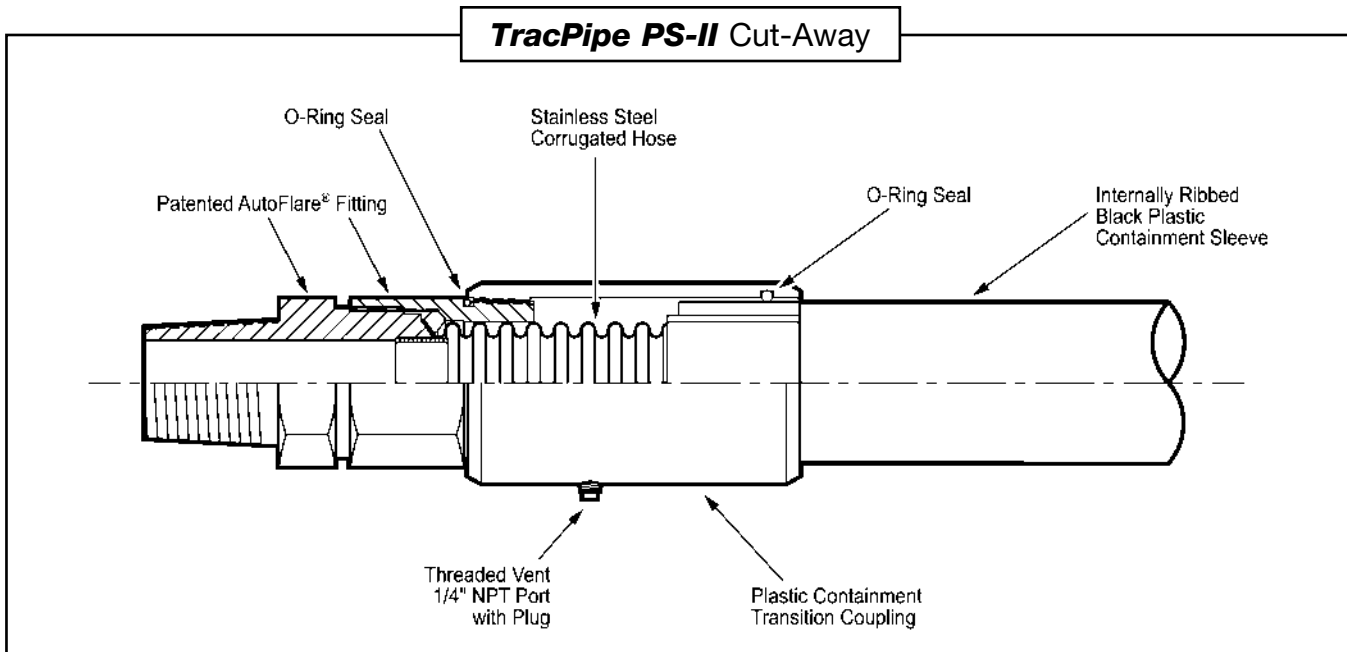

Figure: 4-45

SECTION 4.9.2— TRACPIPE PS-II

1. **TracPipe® PS-II** is a patented system suitable for above ground and underground use. It is designed with our standard CSST tubing and incorporates an internally ribbed sleeve (conduit), and specially designed end fittings that provide vent capability at either end of a piping run in the event of a leak in the CSST. Figure: 4-45

2. **TracPipe® PS-II** complies with all model code requirements for underground/under slab burial and carries the following listings / certifications:

- ICC-ES PMG-1052 Listing
LC1023 PMG Listing Criteria
- IAPMO tested and UPC listed for underground use per IGC 201-2004
- CSA listed to ANSI/CSA LC-1 for above ground use.

NOTICE: The ANSI /CSA LC-1 Standard has no provisions for evaluating CSST for direct burial.

3. For above ground **TracPipe® PS-II** installations, the installer shall meet local build-

ing codes with respect to flame spread and smoke density regulations for non-metallic materials. **TracPipe® PS-II** is not suitable for use in return air plenums or through penetration fire stop systems per UL classification requirements.

4. **TracPipe® PS-II** is supplied in standard lengths on reels or custom cut lengths. Standard reel lengths are 100, 150, and 250 feet (100 foot lengths for sizes up to 1 inch.)

5. **TracPipe® PS-II** lengths can be spliced together by using available couplings. All metallic portions of the fittings underground shall be mastic-wrapped to conform to local codes for under ground piping. Be certain prior to back-filling that no metallic portions of the piping system will be exposed to earth. **No fittings or couplings are permitted under building slabs.**

6. When pressure testing **TracPipe® PS-II**, it is necessary to remove at least one fitting vent plug to insure proper test results on the stainless steel tubing. Codes do not require pressure testing of the sleeve. If local jurisdictions require the sleeve to be tested, do not exceed the pressure of the pipe (25 PSI maximum).

SECTION 4.9.3— TRACPIPE PS-II FITTING ATTACHMENT

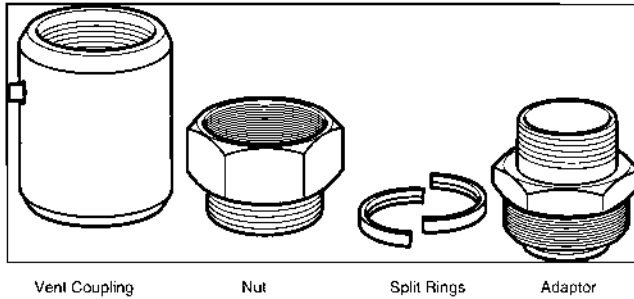

- **TracPipe® PS-II** is constructed from **OmegaFlex®** standard stainless steel flexible gas pipe sleeved in a fully vent-capable polyethylene sleeve.

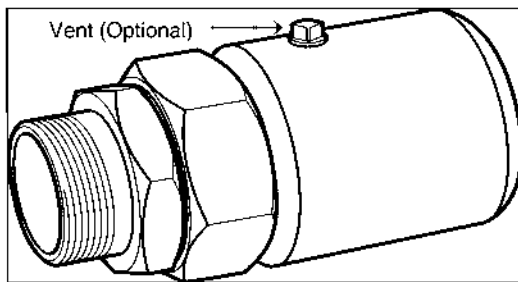

Figure: 4-46

- **TracPipe PS-II fittings** are constructed from **TracPipe® CounterStrike®** patented **AutoFlare®** fittings with a plastic containment coupling and 1/4 inch NPT vent port. Fittings assemble without special tools. Figure 4-46
- When pressure testing **TracPipe PS-II**, it is necessary to remove at least one fitting vent plug to insure proper test results on the stainless steel tubing.

Tools Required for Assembly

- * Utility knife with sharp blade
- * Appropriate size adjustable or monkey wrenches
- * Tubing Cutter:
For up to 3/4" -#151 Ridgid® tubing cutter (FGP-TC-151) w/TracPipe cutting wheel (FGP-E-5272)
For 1" and up -#152 Ridgid® tubing cutter (FGP-TC-152) w/TracPipe cutting wheel (FGP-E-5272)
- * Reciprocating saw or hacksaw

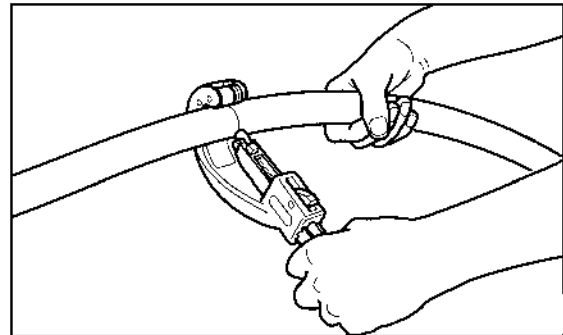

Figure: 4-47

1. Unreel pipe into trench or on the ground and cut to desired length plus one additional foot. Cutting up to 1" size can be done with a large tubing cutter. For 1-1/4 to 2 inch sizes, a reciprocating saw is recommended. Figure: 4-47

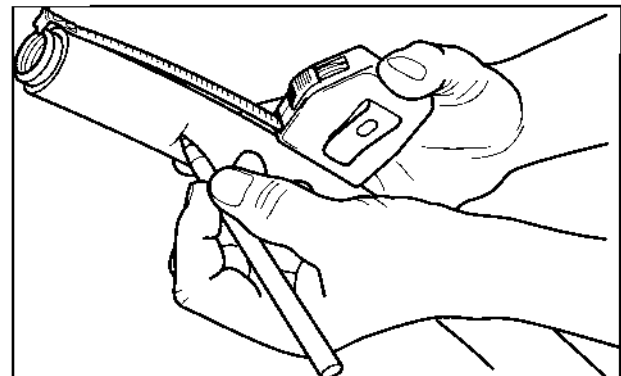

Figure: 4-48

2. Mark the sleeve at specified length on the Strip Length Chart Table: 4-10 - plus 2 inches. Figure: 4-48

Table: 4-10

Jacket Strip Length / Fitting Torque / Superimposed Loading Chart

Size	3/8	1/2	3/4	1	1-1/4	1-1/2	2
Jacket Strip Length	1-1/2"	1-1/2"	1-3/4"	2"	2-1/4"	2-1/2"	2-3/4"
Fitting Torque Value	40 ft-lb	42 ft-lb	45 ft-lb	75 ft-lb	150 ft-lb	200 ft-lb	250 ft-lb
OD for Core Hole Sizing	.820	1.08	1.32	1.6	1.96	2.18	2.8
Max. Superimposed Loading <i>psf</i>	9640	7254	5409	4203	3390	2901	2124

Notes: 1. Super-imposed loading includes all dead load and live load combinations.
2. Maximum buried depth of 36"; 3. Soil Density : 120 pcf; 4. Factor of safety used: 4.

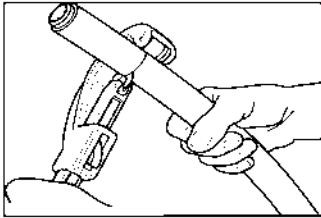

Figure: 4-49

- Using the appropriate tubing cutter with **TracPipe**® #FGP-E-5272 cutting wheel, score the black sleeve approximately half of the way through. Figure: 4-49. Use extreme care not to cut or score the stainless corrugated pipe! Typically, no more than two turns in on the cutter is sufficient.

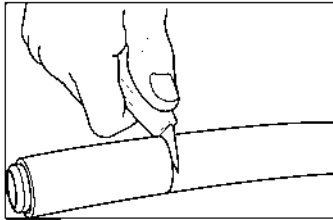

Figure: 4-50

- Finish cutting through the sleeve down to the stainless corrugated pipe using a sharp utility knife. Figure: 4-50

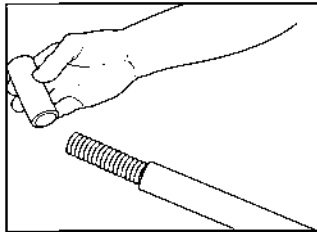

Figure: 4-51

- Using a twisting motion, remove the black sleeve from the pipe. Figure: 4-51. It may be necessary to cut sleeve longitudinally and peel off for larger sizes. **Inspect stainless pipe for scoring from the tubing cutter.**

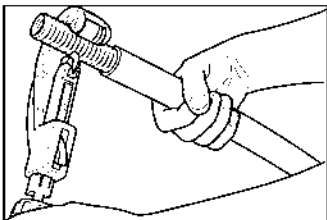

Figure: 4-52

- Using the tubing cutter, trim corrugated pipe to strip length specified in Table: 4-8. Cut slowly in the root of the corrugation in the same manner you would cut copper tubing. Inspect end of pipe for a clean cut without tears in corrugation. Figure: 4-52.

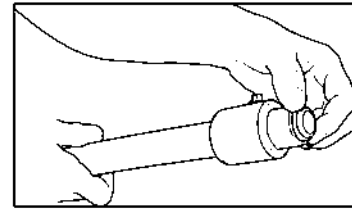

Figure: 4-53

- Remove adapter and split rings from fitting. Attach adapter to equipment. Slip coupling and nut over end of pipe all the way to expose first corrugations of pipe. Insert split rings into first corrugation as shown. Figure: 4-53

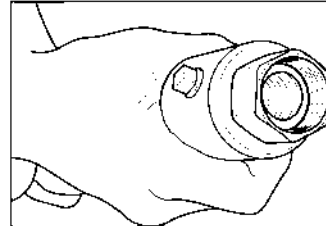

Figure: 4-54

- Holding the black coupling, slide fitting up to capture split rings into nut. Be sure split rings slip all the way to the base of the internal threads. Assembly is now ready to be attached to the adapter on the equipment. Figure: 4-54

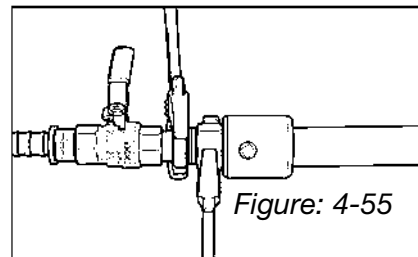

Figure: 4-55

- Thread nut onto adapter previously installed on the equipment. Using appropriate wrenches, hold adapter and tighten nut to proper torque specified. Figure: 4-55. Do not over tighten or use any pipe dope or thread sealants on this connection. This is a metal-to-metal seat and will not seal if pipe dope or thread sealants are used. Sealants are to be used on the NPT connection to the equipment only!

NOTICE: When installing coupling FGP-UGC-SIZE the same instructions apply, except metallic parts of the fitting must be wrapped in a code approved manner (e.g. mastic used for wrapping metallic pipe).

SECTION 4.10 – ELECTRICAL BONDING/GROUNDING



WARNING! **FIRE / FUEL GAS PIPING**

Non-conductive jacketed CSST systems or systems that contain non-conductive jacketed CSST must be additionally bonded per the 2009 or later edition of the UPC, IFGC or NFPA-54.

It is **HIGHLY RECOMMENDED** to equipotentially bond all mechanical systems to the building's grounding electrode.

1. Definitions:

Grounding: The process of making an electrical connection to the general mass of the earth. This is most often accomplished with ground rods, ground mats or some other grounding system. Low resistance grounding is critical to the operation of lightning protection techniques.

Bonding: The process of making an electrical connection between the grounding electrode and any equipment, appliance, or metal conductor: pipes, plumbing, flues, etc. Equipment bonding serves to protect people and equipment in the event of an electrical fault.

Equipotential Bonding: The process of making an electrical connection between the grounding electrode and any metal conductor: pipes, plumbing, flues, etc., which may be exposed to a lightning strike and can be a conductive path for lightning energy towards or away from the grounding electrode.

2. The **TracPipe® CounterStrike®** gas piping system shall be bonded in accordance with these instructions and local codes. In the event of a conflict between these instructions and local codes, the local codes shall control. The piping system is not to be used as a grounding conductor or electrode for an electrical system.

SECTION 4.10.1 - TRACPIPE® COUNTERSTRIKE® BONDING INSTRUCTIONS

For all products date coded 0731 and higher (manufactured after July 30, 2007)

1. The instructions for cutting tubing and for making fitting connections to **TracPipe® CounterStrike®** are located in Section 4.2 of this manual.
2. There are no additional bonding requirements for **TracPipe® CounterStrike®** and underground **TracPipe PS-II** imposed by the manufacturer's installation instructions. **TracPipe® CounterStrike®** is to be bonded in accordance with the National Electrical Code NFPA 70 Article 250.104(B) in the same manner as the minimum requirements for rigid metal piping. Installers must always adhere to any local requirements that may be stricter than these instructions. In these cases see Section 4.10.2.
3. Do not apply any non-metallic labels or paint to **TracPipe® CounterStrike®**.

SECTION 4.10.2 – WHEN BONDING IS REQUIRED

1. When additional bonding of the **TracPipe® CounterStrike®**, yellow jacketed **TracPipe®** or **TracPipe® PS-II®** system is required by local codes, a bonding clamp must be attached to either the brass **TracPipe® AutoFlare® or AutoSnap®** fitting adapter Figure: 4-56, or to a black pipe component (pipe or fitting) within the gas piping system. The corrugated stainless steel portion of the gas piping system SHALL NOT be used as the bonding attachment point.

The bonding should be in accordance with the National Electrical Code NFPA 70. Bonding electrode conductor sizing shall be in accordance with NFPA 70 Article 250.66 and Table: 250-66.

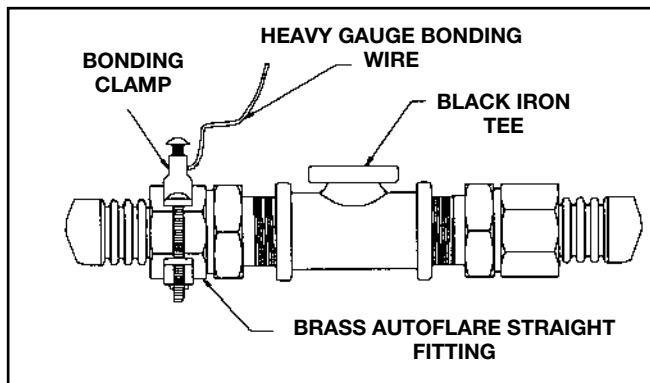

Figure: 4-56

BRASS BONDING CLAMPS

Part No.	Fits <i>TracPipe</i> [®] <i>AutoFlare</i> [®] Fitting	Fits Iron Pipe size
FGP-GC-1	3/8", 1/2"	1/2", 3/4", 1"
FGP-GC-2	3/4", 1", 1-1/4"	1-1/4", 1-1/2", 2"
FGP-GC-3	1-1/2", 2"	2-1/2", 3", 4"

Table: 4-11

2. **TracPipe**[®] bonding clamps have been tested and approved by CSA in accordance with UL 467 / CSA G22.2 No. 41-07 when installed on black iron/galvanized steel pipe and **TracPipe**[®] **AutoFlare**[®] or **AutoSnap**[®] brass hex fittings. Only a single point of attachment is required to protect the entire gas piping system. Table: 4-11.
3. If possible, avoid running the bonding conductor a long distance through the building. The connection should be as short as practical. The bonding clamp can be connected at a point on the piping system near the grounding electrode system.
4. Lightning induced voltages seeking ground are subject to impedance; consider utilizing a multi-stranded bonding jumper for greater surface area, rather than solid wire.

5. Multiple gas meters used for a single building may be bonded with a single bonding conductor installed in a "daisy chain" configuration.
6. Original yellow jacketed **TracPipe**[®] must be bonded in accordance with this Section.

WARNING

- Failure to properly bond the **TracPipe**[®] **CounterStrike**[®] flexible gas piping system in accordance with NEC/NFPA 70 may lead to damage to the CSST system in the event of a lightning strike.
- A lightning induced fire in the building could lead to serious personal injury or significant property damage.
- Lightning is a powerful and unpredictable natural force, and it has the capacity of damaging gas piping systems due to arcing between the gas piping system and other metallic systems in the building.
- If the building to be piped is in a high lightning flash density area or a region with a high number of thunderstorm days per year, consideration should be given to utilizing the Lightning Risk Assessment method given in Annex L of NFPA 780 for a determination of the need for a lightning protection system.

All references to model building codes are to the version of those codes adopted by the local authority having jurisdiction. If there are no such local codes, refer to the current edition of the National Fuel Gas Code NFPA 54 and National Electrical Code NFPA 70.

CHAPTER 5

INSPECTION, REPAIR AND REPLACEMENT

SECTION 5.1 – MINIMUM INSPECTION REQUIREMENTS

TracPipe® CounterStrike® Inspection Checklist

All installations shall be inspected by the authority having jurisdiction in accordance with state and local mechanical/plumbing codes or the National Fuel Gas Code NFPA 54 (ANSI Z 223.1), IFGC or UPC.

- Installer has **TracPipe® CounterStrike®** Training Certification card.
- Inspection and pressure test completed at rough in.
- Strike protection in place where required.
- TracPipe® CounterStrike®** tubing is supported at proper interval.
- No damaged tubing dents or defects. (See 5.2).
- Inspect for electrical bonding where required.

TracPipe® CounterStrike® Flexible Gas Piping

Omega Flex, Inc.
451 Creamery Way, Exton, PA 19341-2509
Toll free: (800) 671-8622
Tel: (610) 524-7272
Fax: (610) 524-7282

SECTION 5.2 – REPAIR OF DAMAGED PIPING

If the tubing is damaged, refer to the following sections to determine the severity of damage and, if necessary, the method of repair.

1. No repairs or replacement of the tubing is necessary if the tubing is only slightly dented due to impact or crushing as indicated in Figure: 5-1.
2. The tubing must be replaced under the following circumstances:
 - a. The tubing has been significantly crushed or dented Figure: 5-2.
 - b. The tubing has been damaged by puncture of any kind, i.e., nails, screws, drill bits, etc.
 - c. The tubing has been bent beyond its minimum bend radius so that a crease or kink remains. Figure: 5-3.

METHOD OF REPAIR

A line splice can be made using a **TracPipe® CounterStrike® AutoFlare®** or **AutoSnap®** coupling. If the tubing run is short and easily accessible, the preferred repair method is to replace the entire length. Tubing run can often be replaced faster than repairing the damaged section with a splice as this does not add any additional fitting joints to the system.

1. Where repairs or replacements involve corrugated stainless steel tubing systems of different manufacturers, the systems can be joined again through standard pipe couplings and the appropriate CSST fittings. Figure: 5-4.

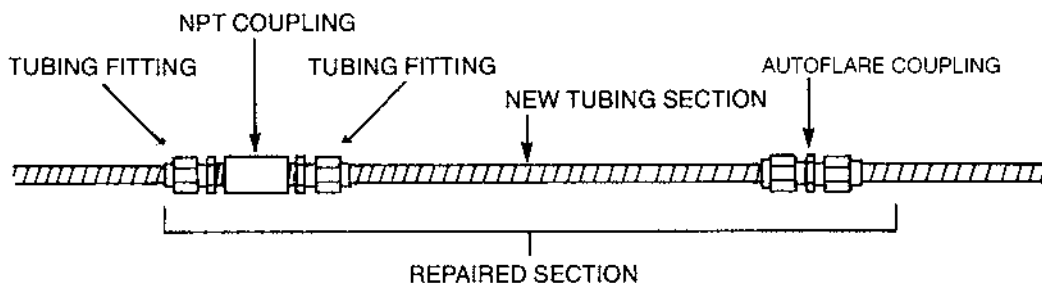

Figure: 5-4 – Repair of Damaged Tubing with a New Section of Tubing and a joint splice or a **TracPipe® CounterStrike® AutoFlare®** or **AutoSnap®** Coupling

SECTION 5.3 – REPAIR OF DAMAGED JACKET

If the **TracPipe® CounterStrike®** jacket has been ripped, torn, cut or has been exposed to an electrical arc, a repair is required. The jacket shall be wrapped using self-bonding silicone tape over the damaged area insuring that the damaged jacket is fully covered and fully wrapped around the jacket circumference.



Figure: 5-1 – Repair Unnecessary. No Significant Damage to the Tubing Due to Impact or Crushing



Figure: 5-2 – Repair Necessary. Significant Damage to the Tubing Due to Impact or Crushing

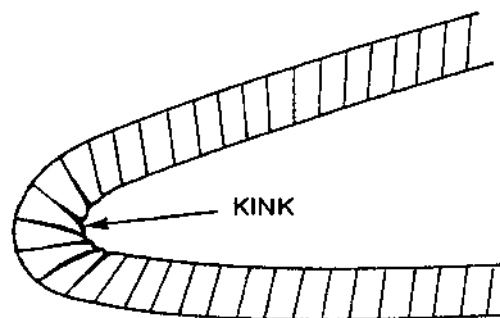

Figure: 5-3 – Repair Necessary. Damage Due to Bending Beyond Minimum Bend Radius

CHAPTER 6

PRESSURE/LEAKAGE TESTING

SECTION 6.0 — PRESSURE TEST PROCEDURE

The final installation must be inspected and tested for leaks at 1 1/2 times the maximum working pressure, but not less than 3 PSI, using the procedures specified in Chapter 8 "Inspection, Testing and Purging" of the National Fuel Gas Code*, NFPA 54/ANSI Z223. 1* or pressure test according to these guidelines or to local codes. When local codes are more stringent, local codes must be followed. If no local codes apply, test according to the National Fuel Gas Code or IFGC or UPC. The installer should never pressure test with the pounds-to-inches regulator installed. This may damage the regulator.

1. Pressure testing should be performed during rough construction of the facility before interior walls are finished. This will permit a more complete inspection of the piping system during the pressure testing, and save costly rework in the event of leaks or other problems. **TracPipe® CounterStrike®** is not responsible for repairs necessary to correct defects discovered after interior walls are finished.

2. Do not connect appliances or pressurize the system with fuel gas until after the pressure test is completed.

3. All gas outlets for appliance connections should be capped during pressure testing.

4. **USE ONLY NON-CORROSIVE LEAK CHECK SOLUTIONS.** Rinse with water and dry the tubing thoroughly after leak detection. (Available: Leak Check Solution P/N FGP-LCS).

5. Most utilities perform a leak test after setting the gas meter and prior to turning on the gas. This test is performed after the final construction is complete and finished interior walls are in place. This test is performed to assure no damage was done to the tubing during the closing-in construc-

tion process.

6. **NOTICE:** When pressure testing **TracPipe® PS-II**, it is necessary to remove at least one fitting vent plug to insure proper test results on the stainless steel tubing. Codes do not require pressure testing of the sleeve. If local jurisdictions require the sleeve to be tested, do not exceed the pressure of the pipe (25 psi maximum).

SECTION 6.1 — Pressure Test for Elevated Pressure Systems

NOTICE: Do not subject **TracPipe® CounterStrike** Sizes 1-1/2 inch or 2 inch to excessive pressure. Pressure test 1-1/2 inch and 2 inch sizes to local code requirements but not to exceed 40 PSI. In the absence of code requirements, test to 1-1/2 times actual working pressure, not to exceed 40 PSI.

Systems above 1/2 PSI requires a two-part pressure test. (See Figure: 6-1) The first part is performed on the elevated pressure section, between the meter connection and the pounds-to-inches line gas pressure regulator.

The second part is performed on the low pressure section, between the pounds-to-inches line gas pressure regulator and the gas appliance outlet. If a steel pipe "jumper" is inserted in place of the line gas pressure regulator the entire system can be pressure tested in one step.

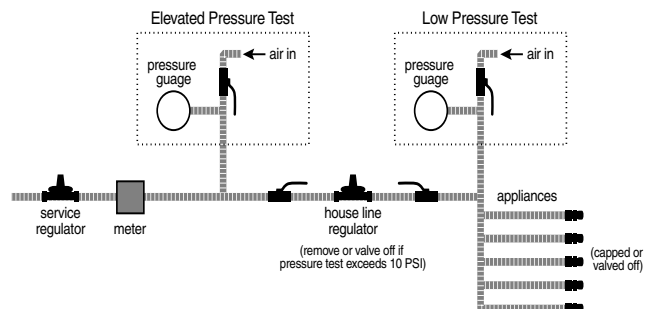

Figure: 6-1 – Pressure Test Requirement for a 2 PSI System

SECTION 6.1.1 – APPLIANCE CONNECTION LEAKAGE CHECK PROCEDURE

1. After the final pressure test, inspection and final construction is complete (finished interior walls) connect the appliances to the tubing system.
2. This final connection can be accomplished by a stainless steel flexible connector, direct connection with CSST tubing or with rigid black pipe. See section 4.6 for installation details and guidelines.
3. Turn the gas on at the meter and inspect for leakage before operating the appliances.
4. Connections made at the appliances should be leak checked with a bubble solution. Before placing the appliances in operation the tubing system should be purged. This displaces the air in the system with fuel gas. Be sure to bleed tubing system into a well ventilated area.

⚠ CAUTION: Leak test solutions may cause corrosion to some types of material in the gas tubing system. Be sure to water rinse after the test and thoroughly dry all contacted material. Also, the vent limiter should not be leak tested with a liquid test solution. This will contaminate the internal ball check mechanism or plug the breathing hole, resulting in erratic regulator operation.

SECTION 6.1.2 – REGULATOR PERFORMANCE - OPTIONAL TESTING

A. Load Response

1. A performance test should be conducted while operating all appliances at full load.

This will insure adequate pressure to each appliance under full-load conditions. To accomplish this, measure the line pressure at the appliance connection while operating the appliance.

2. The inlet pressure for typical natural gas appliances should measure between 4 and 6 inches water column under full-load conditions. If this pressure can not be obtained a slight adjustment to the pounds-to-inches regulator may be necessary to increase the line pressure. Do not set any system regulator over the system design pressure (2 PSI).

B. Spring Adjustment

1. The 2 PSI system pounds-to-inches line gas pressure regulator can be adjusted with an outlet pressure ranging between 7 and 11 inches of water column. The regulator must be adjusted according to the manufacturer's recommended procedure. A pressure gauge mounted just downstream of the regulator can monitor the set pressure under various loads.
2. The regulator is typically set when the system is operating at approximately 75 percent of maximum load.
3. The average natural gas appliance is designed to operate at 3 to 4 inches water column manifold pressure, and a pressure difference of 1 to 2 inches of water column across the appliance regulator which will prevent slow regulator response. Thus, the appliance regulator will operate best at 5 to 6 inches water column inlet pressure. In this case, the 2 PSI line gas pressure regulator should be reset to deliver approximately 8 to 10 inches of water column outlet pressure under load to allow for 3 inches of water column pressure drop in the tubing. Some appliances may have different inlet pressure requirements.

CHAPTER 7

CAPACITY TABLES

SECTION 7.0 – SIZING TABLES

for *TracPipe*® *CounterStrike*® and *TracPipe*® *PS-II* Flexible Gas Piping

STANDARD TABLES

Natural Gas	6-7 inch w.c. / 0.5 inch w.c. drop
	8 inch w.c. / 3 inch w.c. drop
	12-14 inch w.c. / 6 inch w.c. drop
	2 PSI / 1 PSI drop
	5 PSI / 3.5 PSI drop
Propane	11 inch w.c. / 0.5 inch w.c. drop
	2 PSI / 1 PSI drop
	5 PSI / 3.5 PSI drop

ADDITIONAL TABLES

Natural Gas	6-7 inch w.c. / 1 inch w.c. drop
	7-8 inch w.c. / 1.5 inch w.c. drop
	7-8 inch w.c. / 2 inch w.c. drop
	8 inch w.c. / 2.5 inch w.c. drop
	11 inch w.c. / 5 inch w.c. drop
	2 PSI / 1.5 PSI drop
	10 PSI / 7 PSI drop
Propane	25 PSI / 10 PSI drop
	11-12 inch w.c. / 1.0 inch w.c. drop
	12-14 inch w.c. / 2.0 inch w.c. drop
	12-14 inch w.c. / 2.5 inch w.c. drop
	10 PSI / 7 PSI drop
25 PSI / 10 PSI drop	

Table N-1 Low Pressure (Standard)

Maximum Capacity of OmegaFlex TracPipe CSST in Cubic Feet per Hour (CFH) of Natural Gas (1000 BTU per cubic foot approx)

Min. Gas Pressure: 6-7 in w.c.
 Pressure Drop: 0.5 in w.c.
 (Based on a 0.60 Specific Gravity Gas)

Tubing Length (feet)

Size EHD	5	10	15	20	25	30	40	50	60	70	75	80	90	100	125	150	200	250	300	400	500	600	700	800	900	1000	1100	1200	1300	1400	1500	
3/8"	63	45	37	33	29	27	23	21	19	18	17	17	16	15	14	12	11	10	9	8	7	6	6	5	5	5	5	5	4	4	4	4
1/2"	138	99	81	70	63	58	50	45	41	38	37	36	34	32	29	26	23	20	19	16	14	13	12	11	11	10	10	9	9	9	8	8
3/4"	245	201	175	157	143	125	112	102	95	92	89	84	80	71	65	57	51	46	40	36	33	31	29	27	26	24	23	22	22	21	21	21
1"	589	419	343	298	267	244	212	190	174	161	156	151	142	135	121	111	96	86	79	68	61	56	52	48	46	43	41	40	38	37	35	35
1 1/4"	1109	789	646	561	503	460	399	358	327	303	293	284	268	254	228	208	181	162	148	128	115	105	97	91	86	82	78	75	72	69	67	67
1 1/2"	1790	1261	1027	888	793	723	625	559	509	471	455	440	415	393	351	320	277	247	226	195	174	159	147	137	129	123	117	112	107	103	100	100
2"	4142	2934	2398	2078	1860	1698	1472	1317	1203	1114	1076	1042	983	933	835	762	661	591	540	468	419	382	354	331	312	296	283	271	260	251	242	242

see notes below*
 EHD (Equivalent Hydraulic Diameter) A theoretical size which reflects the hydraulic performance of the tubing. It is not a true physical measure. This number is used to compare individual sizes between different manufactures.
 The higher the EHD number the greater the flow capacity of the piping.

Table N-2A Low Pressure (Canada & USA 1 in drop)

Maximum Capacity of OmegaFlex TracPipe CSST in Cubic Feet per Hour (CFH) of Natural Gas (1000 BTU per cubic foot approx)

Min. Gas Pressure: 6-7 in w.c.
 Pressure Drop: 1.0 in w.c.
 (Based on a 0.60 Specific Gravity Gas)

Tubing Length (feet)

Size EHD	5	10	15	20	25	30	40	50	60	70	75	80	90	100	125	150	200	250	300	400	500	600	700	800	900	1000	1100	1200	1300	1400	1500	
3/8"	87	63	52	45	41	37	33	29	27	25	24	23	22	21	19	17	15	14	12	11	10	9	8	8	7	7	7	6	6	6	6	6
1/2"	193	138	113	99	88	81	70	63	58	54	52	50	47	45	40	37	32	29	26	23	20	19	17	16	15	14	14	13	13	12	12	12
3/4"	482	344	282	245	220	201	175	157	143	133	129	125	118	112	100	92	80	71	65	57	51	46	43	40	38	36	34	33	32	31	30	30
1"	827	589	483	419	376	343	298	267	244	227	219	212	200	190	170	156	135	121	111	96	86	79	73	68	64	61	58	56	54	52	50	50
1 1/4"	1558	1109	908	789	707	646	561	503	460	426	412	399	377	358	320	293	254	228	208	181	162	148	137	128	121	115	110	105	101	97	94	94
1 1/2"	2541	1790	1458	1261	1126	1027	888	793	723	669	646	625	589	559	499	455	393	351	320	277	247	226	209	195	184	174	166	159	152	147	142	142
2"	5848	4142	3386	2934	2626	2398	2078	1860	1698	1573	1520	1472	1388	1317	1179	1076	933	835	762	661	591	540	500	468	441	419	399	382	367	354	342	342

*Notes: Tables above include losses for four 90-degree bends and two end fittings. Tubing runs with larger numbers of bends and/or fittings shall be increased by the equivalent length of tubing to the following equation:
 L=1.3n where L is the additional length of tubing and n is the number of additional fittings and/or bends.

Table N-2B Low Pressure (Canada & USA 1.5 in drop)

Maximum Capacity of OmegaFlex TracPipe CSST in Cubic Feet per Hour (CFH) of Natural Gas (1000 BTU per cubic foot approx)

Min. Gas Pressure: 7-8 in w.c.
 Pressure Drop: 1.5 in w.c.
 (Based on a 0.60 Specific Gravity Gas)

Size EHD	Tubing Length (feet)																															
	5	10	15	20	25	30	40	50	60	70	75	80	90	100	125	150	200	250	300	400	500	600	700	800	900	1000	1100	1200	1300	1400	1500	
3/8"	15	105	76	63	55	49	45	39	35	33	30	29	28	27	26	23	21	18	16	15	13	12	11	10	9	9	8	8	8	7	7	7
1/2"	19	235	168	138	120	108	99	86	77	70	65	63	61	58	55	49	45	39	35	32	28	25	23	21	20	19	18	17	16	16	15	14
3/4"	25	587	419	344	299	268	245	213	191	175	162	157	152	143	136	122	112	97	87	80	69	62	57	52	49	46	44	42	40	39	37	36
1"	31	1010	719	589	511	458	419	364	326	298	276	267	259	244	232	208	190	165	148	135	117	105	96	89	83	79	75	71	68	66	63	61
1 1/4"	39	1902	1353	1109	963	863	789	685	614	561	520	503	487	460	436	391	358	310	278	254	221	198	181	168	157	148	141	134	128	123	119	115
1 1/2"	46	3119	2197	1790	1548	1383	1261	1090	974	888	821	793	768	723	686	613	559	483	431	393	340	304	277	256	239	226	214	204	195	187	180	174
2"	62	7156	5069	4142	3590	3213	2934	2543	2276	2078	1925	1860	1801	1698	1612	1442	1317	1141	1021	933	808	723	661	612	572	540	512	488	468	449	433	419

see notes below*
 EHD (Equivalent Hydraulic Diameter) A theoretical size which reflects the hydraulic performance of the tubing. It is not a true physical measure. This number is used to compare individual sizes between different manufactures.
 The higher the EHD number the greater the flow capacity of the piping.

Table N-2C Low Pressure (Canada & USA 2.0 in drop)

Maximum Capacity of OmegaFlex TracPipe CSST in Cubic Feet per Hour (CFH) of Natural Gas (1000 BTU per cubic foot approx)

Min. Gas Pressure: 7-8 in w.c.
 Pressure Drop: 2.0 in w.c.
 (Based on a 0.60 Specific Gravity Gas)

Size EHD	Tubing Length (feet)																															
	5	10	15	20	25	30	40	50	60	70	75	80	90	100	125	150	200	250	300	400	500	600	700	800	900	1000	1100	1200	1300	1400	1500	
3/8"	15	120	87	72	63	56	52	45	41	37	35	34	33	31	29	26	24	21	19	17	15	14	12	11	11	11	10	10	9	9	8	8
1/2"	19	270	193	159	138	124	113	99	88	81	75	73	70	66	63	57	52	45	40	37	32	29	26	24	23	22	20	19	19	18	17	17
3/4"	25	675	482	395	344	308	282	245	220	201	186	180	175	165	157	140	129	112	100	92	80	71	65	60	57	53	51	48	46	45	43	42
1"	31	1162	827	678	589	528	483	419	376	343	318	308	298	281	267	240	219	190	170	156	135	121	111	103	96	91	86	82	79	76	73	70
1 1/4"	39	2191	1558	1277	1109	994	908	789	707	646	599	579	561	529	503	450	412	358	320	293	254	228	208	193	181	171	162	155	148	142	137	133
1 1/2"	46	3607	2541	2070	1790	1599	1458	1261	1126	1027	950	917	888	837	793	709	646	559	499	455	393	351	320	296	277	261	247	236	226	217	209	201
2"	62	8257	5848	4780	4142	3707	3386	2934	2626	2398	2221	2146	2078	1960	1860	1664	1520	1317	1179	1076	933	835	762	706	661	623	591	564	540	519	500	483

*Notes: Tables above include losses for four 90-degree bends and two end fittings. Tubing runs with larger numbers of bends and/or fittings shall be increased by the equivalent length of tubing to the following equation:
 L=1.3n Where L is the additional length of tubing and n is the number of additional fittings and/or bends.

Table N-2D Low Pressure (Canada & USA 2.5 in drop)

Maximum Capacity of OmegaFlex TracPipe CSST in Cubic Feet per Hour (CFH) of Natural Gas (1000 BTU per cubic foot approx)

Min. Gas Pressure: 8 in w.c.
 Pressure Drop: 2.5 in w.c.
 (Based on a 0.60 Specific Gravity Gas)

Size EHD	Tubing Length (feet)																															
	5	10	15	20	25	30	40	50	60	70	75	80	90	100	125	150	200	250	300	400	500	600	700	800	900	1000	1100	1200	1300	1400	1500	
3/8"	133	96	79	69	63	57	50	45	41	38	37	36	34	33	29	27	23	21	19	17	15	14	13	12	11	11	10	10	10	9	9	9
1/2"	301	215	177	154	138	126	110	99	90	84	81	78	74	70	63	58	50	45	41	36	32	29	27	25	24	23	22	21	20	19	19	
3/4"	753	537	441	383	344	314	273	245	224	208	201	195	184	175	157	143	125	112	102	89	80	73	67	63	60	57	54	52	50	48	46	
1"	1297	923	757	657	589	539	468	419	383	355	343	333	314	298	267	244	212	190	174	151	135	124	115	107	101	96	92	88	84	81	79	
1 1/4"	2444	1739	1425	1237	1109	1014	880	789	721	668	646	626	591	561	503	460	399	358	327	284	254	232	215	202	190	181	172	165	159	153	148	
1 1/2"	4038	2844	2317	2004	1790	1632	1411	1261	1150	1064	1027	994	937	888	793	723	625	559	509	440	393	359	332	310	292	277	264	253	243	234	226	
2"	9227	6535	5341	4629	4142	3783	3279	2934	2680	2482	2398	2322	2190	2078	1860	1698	1472	1317	1203	1042	933	852	789	738	696	661	630	603	580	559	540	

see notes below*
 EHD (Equivalent Hydraulic Diameter) A theoretical size which reflects the hydraulic performance of the tubing. It is not a true physical measure. This number is used to compare individual sizes between different manufactures.
 The higher the EHD number the greater the flow capacity of the piping.

Table N-3 Regulator Outlet (8 inches W.C.)

Maximum Capacity of OmegaFlex TracPipe CSST in Cubic Feet per Hour (CFH) of Natural Gas (1000 BTU per cubic foot approx)

Min. Gas Pressure: 8 in w.c.
 Pressure Drop: 3.0 in w.c.
 (Based on a 0.60 Specific Gravity Gas)

Size EHD	Tubing Length (feet)																														
	5	10	15	20	25	30	40	50	60	70	75	80	90	100	125	150	200	250	300	400	500	600	700	800	900	1000	1100	1200	1300	1400	1500
3/8"	160	112	90	78	69	63	55	49	45	42	41	39	37	35	32	29	26	23	21	18	16	15	14	13	12	12	11	11	10	10	10
1/2"	329	235	193	168	151	138	120	108	99	91	88	86	81	77	69	63	55	49	45	39	35	32	30	28	26	25	24	23	22	21	20
3/4"	823	587	482	419	375	344	299	268	245	227	220	213	201	191	171	157	136	122	112	97	87	80	74	69	65	62	59	57	54	52	51
1"	1418	1010	827	719	644	589	511	458	419	389	376	364	343	326	292	267	232	208	190	165	148	135	125	117	111	105	100	96	92	89	86
1 1/4"	2673	1902	1558	1353	1213	1109	963	863	789	731	707	685	646	614	550	503	436	391	358	310	278	254	236	221	208	198	189	181	174	168	162
1 1/2"	4428	3119	2541	2197	1963	1790	1548	1383	1261	1166	1126	1090	1027	974	870	793	686	613	559	483	431	393	364	340	320	304	289	277	266	256	247
2"	10103	7156	5848	5069	4536	4142	3590	3213	2934	2717	2626	2543	2398	2276	2036	1860	1612	1442	1317	1141	1021	933	864	808	762	723	690	661	635	612	591

*Notes: Tables above include losses for four 90-degree bends and two end fittings. Tubing runs with larger numbers of bends and/or fittings shall be increased by the equivalent length of tubing to the following equation:
 L=L+1.3n where L is the additional length of tubing and n is the number of additional fittings and/or bends.

Table N-3A 3P Regulator Outlet (11 inches W.C.)

Maximum Capacity of OmegaFlex TracPipe CSST in Cubic Feet per Hour (CFH) of Natural Gas (1000 BTU per cubic foot approx)

Min Gas Pressure: 11 in w.c.
 Pressure Drop: 5.0 in w.c.
 (Based on a 0.60 Specific Gravity Gas)

Tubing Length (feet)

Size EHD	5	10	15	20	25	30	40	50	60	70	75	80	90	100	125	150	200	250	300	400	500	600	700	800	900	1000	1100	1200	1300	1400	1500	
3/8"	15	207	144	116	100	89	81	70	62	57	53	52	50	47	45	41	37	33	29	27	23	21	19	18	17	16	15	14	14	13	13	12
1/2"	19	421	301	247	215	193	177	154	138	126	117	113	110	104	99	88	81	70	63	58	50	45	41	38	36	34	32	31	29	28	27	26
3/4"	25	1055	753	618	537	482	441	383	344	314	292	282	273	258	245	220	201	175	157	143	125	112	102	95	89	84	80	76	73	70	67	65
1"	31	1822	1297	1063	923	827	757	657	589	539	499	483	468	441	419	376	343	298	267	244	212	190	174	161	151	142	135	129	124	119	115	111
1 1/4"	39	3436	2444	2003	1739	1558	1425	1237	1109	1014	940	908	880	831	789	707	646	561	503	460	399	358	327	303	284	268	254	243	232	223	215	208
1 1/2"	46	5732	4038	3290	2844	2541	2317	2004	1790	1632	1510	1458	1411	1330	1261	1126	1027	888	793	723	625	559	509	471	440	415	393	375	359	345	332	320
2"	62	13026	9227	7541	6535	5848	5341	4629	4142	3783	3504	3386	3279	3092	2934	2626	2398	2078	1860	1698	1472	1317	1203	1114	1042	983	933	890	852	819	789	762

see notes below*
 EHD (Equivalent Hydraulic Diameter) A theoretical size which reflects the hydraulic performance of the tubing. It is not a true physical measure. This number is used to compare individual sizes between different manufactures.
 The higher the EHD number the greater the flow capacity of the piping.

Table N-4 Medium Pressure

Maximum Capacity of OmegaFlex TracPipe CSST in Cubic Feet per Hour (CFH) of Natural Gas (1000 BTU per cubic foot approx)

Min Gas Pressure: 12-14 in w.c. (1/2 PSIG)
 Pressure Drop: 6.0 in w.c.
 (Based on a 0.60 Specific Gravity Gas)

Tubing Length (feet)

Size EHD	5	10	15	20	25	30	40	50	60	70	75	80	90	100	125	150	200	250	300	400	500	600	700	800	900	1000	1100	1200	1300	1400	1500	
3/8"	15	229	160	130	112	99	90	78	69	63	58	56	52	49	44	41	35	32	29	26	23	21	20	18	17	16	16	15	15	14	14	
1/2"	19	461	329	270	235	211	193	168	151	138	128	124	120	113	108	97	88	77	69	63	55	49	45	42	39	37	35	33	32	31	30	29
3/4"	25	1153	823	675	587	526	482	419	375	344	319	308	299	282	268	240	191	171	157	136	122	112	104	97	92	87	83	80	76	74	71	
1"	31	1992	1418	1162	1010	905	827	719	644	589	546	528	511	483	458	411	376	326	292	267	232	208	190	176	165	156	148	141	135	130	125	121
1 1/4"	39	3757	2673	2191	1902	1704	1558	1353	1213	1109	1028	994	963	908	863	773	707	614	550	503	436	391	358	331	310	293	278	265	254	244	236	228
1 1/2"	46	6286	4428	3607	3119	2786	2541	2197	1963	1790	1656	1599	1548	1458	1383	1235	1126	974	870	793	686	613	559	517	483	455	431	411	393	378	364	351
2"	62	14263	10103	8257	7156	6404	5848	5069	4536	4142	3837	3707	3590	3386	3213	2875	2626	2276	2036	1860	1612	1442	1317	1220	1141	1076	1021	974	933	896	864	835

*Notes: Tables above include losses for four 90-degree bends and two end fittings. Tubing runs with larger numbers of bends and/or fittings shall be increased by the equivalent length of tubing to the following equation:
 L=1.3n where L is the additional length of tubing and n is the number of additional fittings and/or bends.

Table N-5 Elevated Pressure 2 psig

Maximum Capacity of OmegaFlex TracPipe CSST in Cubic Feet per Hour (CFH) of Natural Gas (1000 BTU per cubic foot approx)

Gas Pressure: 2 psig
Pressure Drop: 1.0 psi
(Based on a 0.60 Specific Gravity Gas)

Size EHD	Tubing Length (feet)																															
	5	10	15	20	25	30	40	50	60	70	75	80	90	100	125	150	200	250	300	400	500	600	700	800	900	1000	1100	1200	1300	1400	1500	
3/8"	15	410	353	286	246	220	200	172	154	139	128	124	120	112	107	94	87	75	67	61	53	47	43	40	38	36	34	33	31	30	29	28
1/2"	19	965	700	567	493	444	406	353	317	290	269	260	252	238	226	203	186	162	145	133	116	104	95	88	83	78	74	71	68	65	63	61
3/4"	25	2430	1734	1423	1237	1110	1015	883	792	724	672	650	630	595	565	507	464	403	361	331	287	258	236	219	205	193	184	175	168	162	156	151
1"	31	4220	3004	2463	2139	1917	1753	1522	1365	1248	1157	1118	1084	1023	971	871	796	691	620	567	492	441	403	374	350	330	314	299	287	276	266	257
1 1/4"	39	7969	5670	4646	4034	3615	3305	2870	2572	2352	2180	2108	2042	1927	1830	1640	1499	1302	1167	1067	926	830	759	703	659	622	590	563	540	519	500	484
1 1/2"	46	13626	9599	7820	6762	6041	5509	4763	4255	3881	3590	3467	3355	3161	2997	2678	2442	2111	1886	1720	1487	1329	1212	1121	1048	987	936	892	853	820	789	762
2"	62	30546	21637	17684	15326	13715	12526	10855	9715	8872	8217	7940	7689	7251	6881	6158	5624	4874	4362	3983	3452	3089	2821	2613	2445	2306	2188	2087	1998	1920	1851	1788

see notes below
EHD (Equivalent Hydraulic Diameter) A theoretical size which reflects the hydraulic performance of the tubing. It is not a true physical measure. This number is used to compare individual sizes between different manufacturers.
Pressure drop across a regulator will vary with flow rate. FGP-REG-3 has a 3/4 PSI pressure drop at a flow of 250 cubic feet per hour. regulator. The higher the EHD number the greater the flow capacity of the piping.
Table does not include effect of pressure drop across the line regulator. CAUTION: Capacities shown in table may exceed the maximum capacity for a selected regulator.

Table N-5A Elevated Pressure 2 psig

Maximum Capacity of OmegaFlex TracPipe CSST in Cubic Feet per Hour (CFH) of Natural Gas (1000 BTU per cubic foot approx)

Gas Pressure: 2 psig
Pressure Drop: 1.5 psi
(Based on a 0.60 Specific Gravity Gas)

Size EHD	Tubing Length (feet)																															
	5	10	15	20	25	30	40	50	60	70	75	80	90	100	125	150	200	250	300	400	500	600	700	800	900	1000	1100	1200	1300	1400	1500	
3/8"	15	495	438	354	305	271	247	212	189	171	158	153	148	139	131	117	106	91	81	74	64	57	53	49	46	43	41	40	38	37	35	34
1/2"	19	1174	855	690	600	542	495	429	385	353	327	317	307	290	275	247	226	197	177	162	141	126	116	107	101	95	90	86	83	79	77	74
3/4"	25	2960	2112	1734	1507	1352	1237	1075	965	883	819	792	767	724	688	617	565	491	440	403	350	314	287	267	250	236	224	214	205	197	190	184
1"	31	5148	3687	3004	2609	2339	2139	1857	1665	1522	1412	1365	1322	1248	1185	1062	971	843	756	691	600	538	492	456	427	403	383	365	350	337	325	314
1 1/4"	39	9725	6919	5670	4923	4412	4034	3502	3139	2870	2661	2572	2492	2352	2233	2001	1830	1589	1424	1302	1130	1013	926	858	804	759	720	688	659	633	611	590
1 1/2"	46	16725	11782	9599	8300	7415	6762	5847	5223	4763	4406	4255	4119	3881	3679	3287	2997	2592	2315	2111	1826	1631	1487	1376	1286	1212	1149	1095	1048	1006	969	936
2"	62	37374	26473	21637	18751	16781	15326	13282	11886	10855	10054	9715	9408	8872	8419	7534	6881	5963	5337	4874	4224	3780	3452	3197	2992	2821	2677	2553	2445	2350	2265	2188

*Notes: Tables above include losses for four 90-degree bends and two end fittings. Tubing runs with larger numbers of bends and/or fittings shall be increased by the equivalent length of tubing to the following equation:
L=1.3n where L is the additional length of tubing and n is the number of additional fittings and/or bends. Table does not include effect of pressure drop across the line regulator. If regulator loss exceeds 1/4 PSI (based on 8 inch outlet pressure) Do not use this chart. Pressure drop across a regulator will vary with flow rate. FGP-REG-3 has a 1/4 PSI pressure drop at a flow of 145 cubic feet per hour. CAUTION: Capacities shown in table may exceed the maximum capacity for a selected regulator.

Table N-6 Elevated Pressure 5 psig

Maximum Capacity of OmegaFlex TracPipe CSST in Cubic Feet per Hour (CFH) of Natural Gas (1000 BTU per cubic foot approx)

Size EHD	Tubing Length (feet)																															
	5	10	15	20	25	30	40	50	60	70	75	80	90	100	125	150	200	250	300	400	500	600	700	800	900	1000	1100	1200	1300	1400	1500	
3/8"	15	736	672	552	475	420	382	329	293	267	246	238	230	216	205	182	166	143	128	116	100	89	78	73	68	65	62	59	57	54	53	51
1/2"	19	1769	1304	1040	905	827	755	654	586	532	493	479	463	437	415	373	341	297	266	244	212	190	174	162	152	143	136	130	125	120	116	112
3/4"	25	4472	3191	2619	2277	2042	1869	1625	1457	1333	1237	1196	1159	1095	1040	933	853	742	665	609	529	475	434	403	378	356	339	323	310	298	287	278
1"	31	7800	5659	4552	3953	3543	3240	2814	2522	2307	2139	2067	2003	1891	1795	1609	1472	1278	1146	1048	910	815	746	691	647	611	580	554	531	510	492	476
1 1/4"	39	14743	10489	8595	7463	6688	6116	5310	4759	4351	4034	3899	3778	3565	3386	3034	2774	2409	2159	1974	1714	1536	1404	1302	1219	1151	1093	1043	999	960	926	895
1 1/2"	46	25665	18080	14730	12737	11378	10377	8972	8015	7310	6762	6530	6320	5955	5646	5044	4600	3977	3553	3240	2802	2503	2283	2111	1974	1860	1763	1680	1608	1544	1487	1436
2"	62	56970	40353	32981	28583	25580	23361	20246	18119	16547	15326	14809	14341	13524	12834	11485	10489	9090	8135	7430	6439	5762	5262	4874	4561	4301	4081	3892	3727	3582	3452	3336

see notes below*

EHD (Equivalent Hydraulic Diameter) A theoretical size which reflects the hydraulic performance of the tubing. It is not a true physical measure. This number is used to compare individual sizes between different manufacturers. The higher the EHD number the greater the flow capacity of the piping. Table does not include effect of pressure drop across the line regulator. If the regulator loss exceeds 1 PSI (based on 8 inch outlet pressure). Do not use this chart. Pressure drops across a regulator will vary with flow rate. FGP-REG-5A has a 1 PSI pressure drop at a flow of 673 cubic feet per hour. CAUTION: Capacities shown in the table may exceed the maximum capacity for a selected regulator.

Table N-7 Elevated Pressure 10 psig

Maximum Capacity of OmegaFlex TracPipe CSST in Cubic Feet per Hour (CFH) of Natural Gas (1000 BTU per cubic foot approx)

Size EHD	Tubing Length (feet)																															
	5	10	15	20	25	30	40	50	60	70	75	80	90	100	125	150	200	250	300	400	500	600	700	800	900	1000	1100	1200	1300	1400	1500	
3/8"	15	1117	814	676	593	535	492	432	390	359	334	324	314	298	284	256	236	207	187	172	150	136	125	116	109	104	99	95	91	88	85	82
1/2"	19	2584	1879	1560	1367	1233	1134	994	897	825	768	744	723	685	652	589	541	474	428	394	345	311	286	266	251	237	226	216	208	200	194	188
3/4"	25	6126	4488	3741	3288	2975	2741	2409	2179	2008	1874	1817	1765	1674	1597	1444	1331	1170	1058	975	857	775	714	666	628	595	568	544	523	505	488	473
1"	31	10350	7602	6347	5584	5056	4662	4102	3714	3424	3197	3101	3013	2859	2728	2470	2277	2004	1814	1673	1472	1332	1229	1147	1081	1026	979	938	902	871	842	817
1 1/4"	39	15935	11800	9899	8739	7933	7330	6471	5875	5428	5078	4928	4792	4554	4350	3949	3649	3222	2925	2702	2386	2166	2001	1872	1767	1679	1604	1539	1482	1431	1386	1345
1 1/2"	46	30140	21882	18145	15887	14331	13174	11534	10405	9564	8907	8627	8374	7931	7554	6814	6264	5484	4947	4547	3981	3591	3301	3074	2890	2737	2607	2495	2397	2310	2232	2162
2"	62	56970	41709	35073	31015	28194	26081	23064	20966	19394	18158	17630	17150	16308	15590	14172	13110	11593	10539	9749	8621	7837	7249	6787	6410	6096	5827	5595	5390	5209	5047	4900

*Notes: Tables above include losses for four 90-degree bends and two end fittings. Tubing runs with larger numbers of bends and/or fittings shall be increased by the equivalent length of tubing to the following equation: L=1.3n where L is the additional length of tubing and n is the number of additional fittings and/or bends. Table does not include effect of pressure drop across the line regulator. User must size regulator based on an inlet pressure between 3 and 10 psig with the desired outlet pressure and capacity required.

Table N-8 Elevated Pressure 25 psig

Maximum Capacity of OmegaFlex TracPipe CSST in Cubic Feet per Hour (CFH) of Natural Gas (1000 BTU per cubic foot approx)

Gas Pressure: 25 psig
 Pressure Drop: 10.0 psi
 (Based on a 0.60 Specific Gravity Gas)

Tubing Length (feet)

Size EHD	5	10	15	20	25	30	40	50	60	70	75	80	90	100	125	150	200	250	300	400	500	600	700	800	900	1000	1100	1200	1300	1400	1500
3/8"	1731	1252	1036	906	816	750	655	591	542	505	489	474	449	427	385	353	309	278	256	223	201	185	172	161	153	145	139	134	129	124	120
1/2"	3751	2735	2274	1995	1802	1658	1454	1314	1209	1127	1092	1060	1005	958	865	796	698	631	580	509	460	423	394	371	352	335	321	308	297	287	279
3/4"	9332	6813	5667	4973	4494	4137	3631	3281	3020	2816	2729	2650	2512	2395	2164	1992	1748	1580	1454	1276	1153	1062	990	932	883	842	806	775	747	723	700
1"	15861	11616	9681	8507	7696	7090	6230	5636	5193	4845	4697	4563	4328	4127	3734	3440	3023	2734	2519	2214	2002	1845	1721	1621	1538	1466	1405	1351	1303	1261	1222
1 1/4"	24879	18276	15259	13426	12157	11209	9863	8930	8234	7689	7456	7245	6875	6560	5940	5477	4819	4364	4023	3540	3205	2956	2760	2600	2468	2355	2257	2171	2095	2027	1966
1 1/2"	44300	32270	26810	23506	21227	19529	17122	15462	14225	13257	12846	12472	11819	11263	10171	9357	8204	7408	6816	5976	5396	4965	4627	4353	4125	3931	3763	3616	3486	3370	3266
2"	79820	59313	49856	44075	40057	37047	32751	29765	27529	25770	25019	24337	23139	22118	20102	18591	16436	14937	13815	12213	11099	10266	9609	9075	8629	8248	7918	7628	7371	7141	6933

see notes below*

EHD (Equivalent Hydraulic Diameter): A theoretical size which reflects the hydraulic performance of the tubing. It is not a true physical measure. This number is used to compare individual sizes between different manufactures. The higher the EHD number the greater the flow capacity of the piping. *Table does not include effect of pressure drop across the regulator. User must size the regulator based on an inlet pressure between 15 and 25 psig with the desired outlet pressure range and capacity required.

Table P-1 Propane Low Pressure (Standard)

Maximum Capacity of OmegaFlex TracPipe CSST in Thousands of BTU per Hour Propane Gas

Min. Gas Pressure: 11 in w.c.
Pressure Drop: 0.5 in w.c.
(Based on a 1.52 Specific Gravity / 2520 BTU per cubic foot Gas)

Size EHD	Tubing Length (feet)																																
	5	10	15	20	25	30	40	50	60	70	75	80	90	100	125	150	200	250	300	400	500	600	700	800	900	1000	1100	1200	1300	1400	1500		
3/8"	15	100	71	59	52	46	43	36	33	30	28	27	27	25	24	22	19	17	16	14	13	11	9	9	8	8	8	8	8	8	6	6	6
1/2"	19	218	157	128	111	100	92	79	71	65	60	59	57	54	51	46	41	36	32	30	25	22	21	19	17	17	16	16	14	14	14	13	
3/4"	25	545	388	318	277	249	226	198	177	161	150	146	141	133	127	112	103	90	81	73	63	57	52	49	46	43	41	38	36	35	35	33	
1"	31	933	663	543	472	423	386	336	301	275	255	247	239	225	214	192	176	152	136	125	108	97	89	82	76	73	68	65	63	60	59	55	
1 1/4"	39	1756	1249	1023	888	796	728	632	567	518	480	464	450	424	402	361	329	287	256	234	203	182	166	154	144	136	130	123	119	114	109	106	
1 1/2"	46	2834	1997	1626	1406	1256	1145	990	885	806	746	720	697	657	622	556	507	439	391	358	309	275	252	233	217	204	195	185	177	169	163	158	
2"	62	6558	4645	3797	3290	2945	2688	2331	2085	1905	1764	1704	1650	1556	1477	1322	1206	1047	936	855	741	663	605	560	524	494	469	448	429	412	397	383	

*Notes: Tables above include losses for four 90-degree bends and two end fittings. Tubing runs with larger numbers of bends and/or fittings shall be increased by the equivalent length of tubing to the following equation:
 $L = 1.3n$ where L is the additional length of tubing and n is the number of additional fittings and/or bends.

Table P-1A Propane Low Pressure

Maximum Capacity of TracPipe CSST in Thousands of BTU per Hour Propane Gas

Min. Gas Pressure: 11-12 in w.c.
Pressure Drop: 1.0 in w.c.
(Based on a 1.52 Specific Gravity / 2520 BTU per cubic foot Gas)

Size EHD	Tubing Length (feet)																															
	5	10	15	20	25	30	40	50	60	70	75	80	90	100	125	150	200	250	300	400	500	600	700	800	900	1000	1100	1200	1300	1400	1500	
3/8"	15	138	100	82	71	65	59	52	46	43	40	38	36	35	33	30	27	24	22	19	17	16	14	13	13	11	11	11	9	9	9	9
1/2"	19	306	218	179	157	139	128	111	100	92	85	82	79	74	71	63	59	51	46	41	36	32	30	27	25	24	22	22	21	21	19	19
3/4"	25	763	545	446	388	348	318	277	249	226	211	204	198	187	177	158	146	127	112	103	90	81	73	68	63	60	57	54	52	51	49	47
1"	31	1309	933	765	663	595	543	472	423	386	359	347	336	317	301	269	247	214	192	176	152	136	125	116	108	101	97	92	89	85	82	79
1 1/4"	39	2467	1756	1438	1249	1119	1023	888	796	728	674	652	632	597	567	507	464	402	361	329	287	256	234	217	203	192	182	174	166	160	154	149
1 1/2"	46	4023	2834	2308	1997	1783	1626	1406	1256	1145	1059	1023	990	933	885	790	720	622	556	507	439	391	358	331	309	291	275	263	252	241	233	225
2"	62	9259	6558	5361	4645	4158	3797	3290	2945	2688	2490	2407	2331	2198	2085	1867	1704	1477	1322	1206	1047	936	855	792	741	698	663	632	605	581	560	541

*Notes: EHD (Equivalent Hydraulic Diameter) A theoretical size which reflects the hydraulic performance of the tubing. It is not a true physical measure. This number is used to compare individual sizes between different manufacturers. The higher the EHD number the greater the flow capacity of the piping. Tables above include losses for four 90-degree bends and two end fittings. Tubing runs with larger numbers of bends and/or fittings shall be increased by the equivalent length of tubing to the following equation: $L = 1.3n$ where L is the additional length of tubing and n is the number of additional fittings and/or bends.

Table P-1B Propane

Size EHD		Maximum Capacity of TracPipe CSST in Thousands of BTU per Hour Propane Gas																														
		Min. Gas Pressure: 12-14 in w.c.										Pressure Drop: 2.0 in w.c.																				
		(Based on a 1.52 Specific Gravity / 2520 BTU per cubic foot Gas)																														
		Tubing Length (feet)																														
		5	10	15	20	25	30	40	50	60	70	75	80	90	100	125	150	200	250	300	400	500	600	700	800	900	1000	1100	1200	1300	1400	1500
3/8"	15	190	138	114	100	89	82	71	65	59	55	54	52	49	46	41	38	33	30	27	24	22	19	17	17	16	16	14	14	13	13	13
1/2"	19	427	306	252	218	196	179	157	139	128	119	116	111	104	100	90	82	71	63	59	51	46	41	38	36	35	32	30	28	27	27	
3/4"	25	1069	763	625	545	488	446	388	348	318	294	285	277	261	249	222	204	177	158	146	127	112	103	95	90	84	81	76	73	71	68	66
1"	31	1840	1309	1073	933	836	765	663	595	543	503	488	472	445	423	380	347	301	269	247	214	192	176	163	152	144	136	130	125	120	116	111
1 1/4"	39	3469	2467	2022	1756	1574	1438	1249	1119	1023	948	917	888	838	796	712	652	567	507	464	402	361	329	306	287	271	256	245	234	225	217	211
1 1/2"	46	5711	4023	3277	2834	2532	2308	1997	1783	1626	1504	1452	1406	1325	1256	1123	1023	885	790	720	622	556	507	469	439	413	391	374	358	344	331	318
2"	62	13073	9259	7568	6558	5869	5361	4645	4158	3797	3516	3398	3290	3103	2945	2635	2407	2085	1867	1704	1477	1322	1206	1118	1047	986	936	893	855	822	792	763

Notes: EHD (Equivalent Hydraulic Diameter). A theoretical size which reflects the hydraulic performance of the tubing. It is not a true physical measure. This number is used to compare individual sizes between different manufactures. The higher the EHD number the greater the flow capacity of the piping.

Table P-2 Propane Medium Pressure

Size EHD		Maximum Capacity of TracPipe CSST in Thousands of BTU per Hour Propane Gas																														
		Min. Gas Pressure: 13-14 in w.c.										Pressure Drop: 2.5 in w.c.																				
		(Based on a 1.52 Specific Gravity / 2520 BTU per cubic foot Gas)																														
		Tubing Length (feet)																														
		5	10	15	20	25	30	40	50	60	70	75	80	90	100	125	150	200	250	300	400	500	600	700	800	900	1000	1100	1200	1300	1400	1500
3/8"	15	222	159	131	114	102	93	81	73	67	62	60	58	55	52	46	43	36	33	30	27	24	22	21	19	17	17	16	16	14	14	14
1/2"	19	491	353	290	254	228	209	182	164	150	140	135	131	124	118	108	97	85	76	70	57	51	46	43	40	38	36	35	33	32	30	30
3/4"	25	1192	850	698	606	545	497	432	388	355	329	318	309	291	277	249	226	198	177	161	141	127	116	106	100	95	90	85	82	79	76	73
1"	31	2512	1863	1720	1343	1106	976	883	825	771	719	696	673	632	596	533	470	398	352	320	239	214	196	182	169	160	152	146	139	133	128	125
1 1/4"	39	3870	2753	2256	1959	1756	1605	1393	1249	1142	1058	1023	991	936	888	796	728	632	567	518	450	402	367	340	320	301	287	272	261	252	242	234
1 1/2"	46	6393	4503	3668	3173	2834	2584	2234	1997	1821	1685	1626	1574	1484	1406	1256	1145	990	885	806	697	622	568	526	491	462	439	418	401	385	370	358
2"	62	14609	10347	8456	7329	6558	5990	5192	4645	4243	3930	3797	3676	3467	3290	2945	2688	2331	2085	1905	1650	1477	1349	1249	1168	1102	1047	997	955	918	885	855

Notes: Tables above include losses for four 90-degree bends and two end fittings. Tubing runs with larger numbers of bends and/or fittings shall be increased by the following equation: L=1.3n where L is the additional length of tubing and n is the number of additional fittings and/or bends.

Table P-3 Propane Elevated Pressure 2 psig

Size EHD		Maximum Capacity of TracPipe CSST in Thousands of BTU per Hour Propane Gas																														
		Min. Gas Pressure: 2 psig										Pressure Drop: 1.0 psi																				
		(Based on a 1.52 Specific Gravity / 2520 BTU per cubic foot Gas)																														
		Tubing Length (feet)																														
		5	10	15	20	25	30	40	50	60	70	75	80	90	100	125	150	200	250	300	400	500	600	700	800	900	1000	1100	1200	1300	1400	1500
3/8"	15	649	558	453	389	347	316	271	243	220	203	196	189	177	169	144	137	118	105	96	84	74	68	63	60	57	54	52	49	47	46	44
1/2"	19	1528	1106	898	781	701	643	559	502	459	426	412	399	377	358	321	294	256	230	211	184	165	150	139	131	123	117	112	108	103	100	97
3/4"	25	3847	2745	2253	1959	1757	1607	1398	1254	1146	1064	1029	997	942	895	803	735	638	572	524	454	408	374	347	325	306	291	277	266	256	247	239
1"	31	6681	4756	3900	3387	3035	2775	2410	2161	1976	1832	1770	1716	1620	1537	1379	1260	1094	982	898	779	698	638	592	554	522	497	473	454	437	421	407
1 1/4"	39	12617	8977	7356	6387	5724	5233	4544	4072	3724	3452	3338	3233	3051	2897	2597	2373	2061	1848	1689	1466	1314	1202	1113	1043	985	934	891	855	822	792	766
1 1/2"	46	21574	15198	12381	10706	9565	8722	7541	6737	6145	5684	5489	5312	5005	4745	4240	3866	3342	2986	2723	2354	2104	1919	1775	1659	1563	1482	1412	1351	1298	1249	1206
2"	62	48362	34257	27999	24265	21715	19832	17186	15381	14047	13010	12571	12174	11480	10894	9750	8904	7717	6906	6306	5465	4891	4466	4137	3871	3651	3464	3304	3163	3040	2931	2831

Notes: EHD (Equivalent Hydraulic Diameter) A theoretical size which reflects the hydraulic performance of the tubing. It is not a true physical measure. This number is used to compare individual sizes between different manufacturers. The higher the EHD number the greater the flow capacity of the piping. Table does not include effect of pressure drop across the line regulator. If the regulator loss exceeds 1/2 PSI (based on 11 inch outlet pressure) Do not use this chart. Pressure drops across a regulator will vary with flow rate. FGP-REG-5P has a 1/2 PSI pressure drop at a flow of 307 cubic feet per hour (774 MBTU/h). CAUTION: Capacities shown in the table may exceed the maximum capacity for a selected regulator.

Table P-6 Propane Elevated Pressure 25 psig

Size EHD		Maximum Capacity of TracPipe CSST in Thousands of BTU per Hour Propane Gas																														
		Min. Gas Pressure: 25 psig										Pressure Drop: 10.0 psi																				
		(Based on a 1.52 Specific Gravity / 2520 BTU per cubic foot Gas)																														
		Tubing Length (feet)																														
		5	10	15	20	25	30	40	50	60	70	75	80	90	100	125	150	200	250	300	400	500	600	700	800	900	1000	1100	1200	1300	1400	1500
3/8"	15	2741	1982	1640	1434	1292	1187	1037	936	858	800	774	750	711	676	610	559	489	440	405	353	318	293	272	255	242	230	220	212	204	196	190
1/2"	19	5939	4330	3600	3159	2853	2625	2302	2080	1914	1784	1729	1678	1591	1517	1370	1260	1105	999	918	806	728	670	624	587	557	530	508	488	470	454	442
3/4"	25	14775	10787	8972	7874	7115	6550	5749	5195	4781	4458	4321	4196	3977	3792	3426	3154	2768	2502	2302	2020	1826	1681	1567	1476	1398	1333	1276	1227	1183	1145	1108
1"	31	25112	18391	15328	13469	12185	11225	9864	8923	8222	7671	7437	7224	6852	6534	5912	5446	4786	4329	3988	3505	3170	2921	2725	2566	2435	2321	2224	2139	2063	1997	1935
1 1/4"	39	39390	28936	24159	21257	19248	17747	15616	14139	13037	12174	11805	11471	10885	10386	9405	8672	7630	6909	6369	5605	5074	4680	4370	4116	3908	3729	3573	3437	3317	3209	3113
1 1/2"	46	70139	51092	42447	37216	33608	30920	27109	24480	22522	20989	20339	19747	18713	17832	16103	14815	12989	11729	10792	9462	8543	7861	7326	6892	6531	6224	5958	5725	5519	5336	5171
2"	62	126376	93908	78935	69783	63421	58655	51854	47126	43586	40801	39612	38532	36635	35019	31827	29435	26023	23649	21873	19336	17573	16254	15214	14368	13662	13055	12536	12071	11670	11306	10977

Table does not include effect of pressure drop across the line regulator. If the regulator loss exceeds 1 PSI (based on 11 inch outlet pressure) Do not use this chart. Pressure drops across a regulator will vary with flow rate. FGP-REG-5P has a 1 PSI pressure drop at a flow of 434 cubic feet per hour (1094 MBTU/h). CAUTION: Capacities shown in the table may exceed the maximum capacity for a selected regulator.

Table P-5 Propane Elevated Pressure 10 psig

Maximum Capacity of TracPipe CSST in Thousands of BTU per Hour Propane Gas

Min. Gas Pressure: 10 psig
Pressure Drop: 7.0 psi
(Based on a 1.52 Specific Gravity / 2520 BTU per cubic foot Gas)

Tubing Length (feet)

Size EHD	5	10	15	20	25	30	40	50	60	70	75	80	90	100	125	150	200	250	300	400	500	600	700	800	900	1000	1100	1200	1300	1400	1500
3/8"	15	1769	1289	1070	939	847	779	684	617	568	529	513	497	472	450	374	328	296	272	237	215	198	184	173	165	157	150	144	139	135	130
1/2"	19	4091	2975	2470	2164	1952	1795	1574	1420	1306	1216	1178	1145	1085	1032	857	750	678	624	546	492	453	421	397	375	358	342	329	317	307	298
3/4"	25	9699	7106	5923	5206	4710	4340	3814	3450	3179	2967	2877	2794	2650	2528	2107	1852	1675	1544	1357	1227	1130	1054	994	942	899	861	828	800	773	749
1"	31	16387	12036	10049	8841	8005	7381	6495	5880	5421	5062	4910	4770	4527	4319	3605	3173	2872	2649	2331	2109	1946	1816	1712	1624	1550	1485	1428	1379	1333	1294
1 1/4"	39	25229	18683	15673	13836	12560	11605	10245	9302	8594	8040	7802	7587	7210	6887	5777	5101	4631	4278	3778	3429	3168	2964	2798	2658	2540	2437	2346	2266	2194	2129
1 1/2"	46	47720	34645	28728	25153	22690	20858	18261	16474	15142	14102	13659	13258	12557	11960	9918	8683	7832	7199	6303	5686	5226	4867	4576	4333	4128	3950	3795	3657	3534	3423
2"	62	90199	66037	55530	49105	44639	41293	36516	33195	30706	28749	27913	27153	25820	24683	20757	18355	16686	15435	13649	12408	11477	10746	10149	9652	9226	8858	8534	8247	7991	7758

Notes: EHD (Equivalent Hydraulic Diameter). A theoretical size which reflects the hydraulic performance of the tubing. It is not a true physical measure. This number is used to compare individual sizes between different manufacturers. The higher the EHD number the greater the flow capacity of the piping. Table does not include effect of pressure drop across the regulator. User must size the regulator based on an inlet pressure between 3 and 10 psig with the desired outlet pressure range and capacity required.

Table P-6 Propane Elevated Pressure 25 psig

Maximum Capacity of TracPipe CSST in Thousands of BTU per Hour Propane Gas

Min. Gas Pressure: 25 psig
Pressure Drop: 10.0 psi
(Based on a 1.52 Specific Gravity / 2520 BTU per cubic foot Gas)

Tubing Length (feet)

Size EHD	5	10	15	20	25	30	40	50	60	70	75	80	90	100	125	150	200	250	300	400	500	600	700	800	900	1000	1100	1200	1300	1400	1500	
3/8"	15	2741	1982	1640	1434	1292	1187	1037	936	858	800	774	750	711	676	610	559	489	440	405	353	318	293	272	255	242	230	220	212	204	196	190
1/2"	19	5939	4330	3600	3159	2853	2625	2302	2080	1914	1784	1729	1678	1591	1517	1370	1260	1105	999	918	806	728	670	624	587	557	530	508	488	470	454	442
3/4"	25	14775	10787	8972	7874	7115	6550	5749	5195	4781	4458	4321	4196	3977	3792	3426	2768	2502	2302	2020	1826	1681	1567	1476	1398	1333	1276	1227	1183	1145	1108	
1"	31	25112	18391	15328	13469	12185	11225	9864	8923	8222	7671	7437	7224	6852	6534	5912	5446	4786	4329	3988	3505	3170	2921	2725	2566	2435	2321	2224	2139	2063	1997	1935
1 1/4"	39	39390	28936	24159	21257	19248	17747	15616	14139	13037	12174	11805	11471	10885	10386	9405	8672	7630	6909	6369	5605	5074	4680	4370	4116	3908	3729	3573	3437	3317	3209	3113
1 1/2"	46	70139	51092	42447	37216	33608	30920	27109	24480	22522	20989	20339	19747	18713	17832	16103	14815	12989	11729	10792	9462	8543	7861	7326	6892	6531	6224	5958	5725	5519	5336	5171
2"	62	126376	93908	78935	69783	63421	58655	51854	47126	43586	40801	39612	38532	36635	35019	31827	29435	26023	23649	21873	19336	17573	16254	15214	14368	13662	13059	12536	12077	11670	11306	10977

Notes: Tables above include losses for four 90-degree bends and two end fittings. Tubing runs with larger numbers of bends and/or fittings shall be increased by the equivalent length of tubing to the following equation: L=1.3n where L is the additional length of tubing and n is the number of additional fittings and/or bends. Table does not include effect of pressure drop across the inlet pressure regulator. User must size regulator based on an inlet pressure between 15 and 25 psig with the desired outlet pressure and capacity required.

SECTION 7.1 – PRESSURE DROP PER FOOT TABLES-
NATURAL GAS for *TracPipe® CounterStrike®*
and Steel Pipe

For propane (LP) gas applications:

1. Convert propane BTU load to CFH propane (divide by 2520 BTU per cubic foot).
2. Multiply CFH propane (1.52 SG) value by 1.5916 to obtain equivalent CFH Natural Gas (0.6 SG) value.
3. Find pressure drop per foot using CFH Natural Gas value from Step 2. This is the pressure drop per foot for Propane at the given BTU load.
4. Follow Sum of Pressure Loss instructions.

To convert 1,000 BTU values to CFH (Propane) use the following formula:

$$\text{Propane} = 2520 \text{ BTU/Cu.Ft.}$$

Section 7.1 - Table PD-1A

**Pressure drop ("wc per foot) for TracPipe based on a given CFH Flow
(Natural Gas SG = 0.60 Gas) at Inlet Pressures up to 5 psig**

Note: For Propane (LP) Gas applications, obtain Pressure Drop per foot values by following the Propane conversion method detailed in Section 7.1 of the TracPipe D&I Guide.

CFH	3/8"	1/2"	3/4"	1"	1-1/4"	1-1/2"	2"
10	0.0019	0.0004	0.0001				
20	0.0085	0.0018	0.0003	0.0001			
30	0.0204	0.0042	0.0007	0.0002	0.0001		
40	0.0377	0.0077	0.0012	0.0004	0.0001	0.0001	
50	0.0609	0.0121	0.0019	0.0007	0.0002	0.0001	
60	0.0900	0.0177	0.0028	0.0009	0.0003	0.0001	
70	0.1253	0.0244	0.0038	0.0013	0.0004	0.0002	
80	0.1668	0.0321	0.0050	0.0017	0.0005	0.0002	
90	0.2146	0.0410	0.0064	0.0022	0.0006	0.0003	
100	0.2690	0.0509	0.0079	0.0027	0.0007	0.0003	0.0001
110	0.3300	0.0620	0.0096	0.0033	0.0009	0.0004	0.0001
120	0.3976	0.0743	0.0115	0.0039	0.0011	0.0005	0.0001
130	0.4721	0.0876	0.0135	0.0046	0.0013	0.0006	0.0001
140	0.5533	0.1022	0.0158	0.0053	0.0015	0.0006	0.0001
150	0.6415	0.1178	0.0182	0.0061	0.0017	0.0007	0.0001
160	0.7367	0.1347	0.0207	0.0070	0.0019	0.0008	0.0001
170	0.8389	0.1526	0.0235	0.0079	0.0022	0.0009	0.0002
180	0.9482	0.1718	0.0264	0.0089	0.0025	0.0011	0.0002
190	1.0647	0.1921	0.0295	0.0099	0.0028	0.0012	0.0002
200	1.1884	0.2136	0.0328	0.0110	0.0031	0.0013	0.0002
225	1.5297	0.2726	0.0418	0.0140	0.0039	0.0017	0.0003
250	1.9172	0.3390	0.0519	0.0174	0.0048	0.0020	0.0004
275	2.3517	0.4128	0.0631	0.0211	0.0058	0.0025	0.0004
300	2.8338	0.4943	0.0755	0.0252	0.0070	0.0029	0.0005
325	3.3642	0.5833	0.0890	0.0297	0.0082	0.0034	0.0006
350	3.9433	0.6799	0.1036	0.0345	0.0095	0.0040	0.0007
375	4.5717	0.7842	0.1193	0.0398	0.0110	0.0045	0.0008
400	5.2499	0.8962	0.1363	0.0454	0.0125	0.0052	0.0009
425	5.9783	1.0159	0.1543	0.0513	0.0142	0.0058	0.0010
450	6.7575	1.1434	0.1736	0.0577	0.0159	0.0065	0.0012
475	7.5877	1.2788	0.1940	0.0644	0.0178	0.0072	0.0013
500	8.4694	1.4219	0.2155	0.0715	0.0197	0.0080	0.0014
525	9.4030	1.5729	0.2382	0.0790	0.0218	0.0088	0.0016
550		1.7318	0.2621	0.0868	0.0240	0.0097	0.0017
575		1.8986	0.2872	0.0951	0.0262	0.0106	0.0019
600		2.0733	0.3134	0.1037	0.0286	0.0115	0.0021
625		2.2560	0.3408	0.1127	0.0311	0.0125	0.0022
650		2.4467	0.3694	0.1221	0.0337	0.0135	0.0024
675		2.6453	0.3992	0.1319	0.0364	0.0145	0.0026

Section 7.1 - Table PD-1A

Pressure drop ("wc per foot) for TracPipe based on a given CFH Flow
(Natural Gas SG = 0.60 Gas) at Inlet Pressures up to 5 psig

Note: For Propane (LP) Gas applications, obtain Pressure Drop per foot values by following the Propane conversion method detailed in Section 7.1 of the TracPipe D&I Guide.

CFH	1/2"	3/4"	1"	1-1/4"	1-1/2"	2"
700	2.8520	0.4301	0.1420	0.0392	0.0156	0.0028
725	3.0668	0.4623	0.1526	0.0421	0.0167	0.0030
750	3.2895	0.4956	0.1635	0.0451	0.0179	0.0032
775	3.5204	0.5302	0.1748	0.0482	0.0191	0.0034
800	3.7594	0.5659	0.1865	0.0514	0.0203	0.0037
825	4.0065	0.6028	0.1986	0.0547	0.0216	0.0039
850	4.2617	0.6410	0.2110	0.0582	0.0229	0.0041
875	4.5250	0.6803	0.2239	0.0617	0.0243	0.0044
900	4.7966	0.7208	0.2371	0.0653	0.0256	0.0046
925	5.0763	0.7625	0.2507	0.0691	0.0271	0.0049
950	5.3642	0.8055	0.2648	0.0729	0.0285	0.0052
975	5.6603	0.8496	0.2792	0.0769	0.0300	0.0055
1000	5.9647	0.8950	0.2940	0.0810	0.0316	0.0057
1100	7.2646	1.0885	0.3571	0.0983	0.0381	0.0070
1200	8.6972	1.3015	0.4264	0.1174	0.0453	0.0083
1300		1.5341	0.5020	0.1382	0.0531	0.0097
1400		1.7864	0.5839	0.1607	0.0615	0.0113
1500		2.0584	0.6722	0.1849	0.0705	0.0130
1600		2.3502	0.7668	0.2109	0.0801	0.0148
1700		2.6619	0.8677	0.2386	0.0903	0.0167
1800		2.9935	0.9750	0.2680	0.1011	0.0187
1900		3.3451	1.0887	0.2992	0.1125	0.0209
2000		3.7168	1.2088	0.3322	0.1245	0.0231
2100		4.1086	1.3353	0.3669	0.1371	0.0255
2200		4.5206	1.4682	0.4033	0.1503	0.0280
2300		4.9528	1.6075	0.4415	0.1641	0.0306
2400		5.4053	1.7533	0.4815	0.1786	0.0334
2500		5.8781	1.9056	0.5233	0.1936	0.0362
2600		6.3713	2.0643	0.5668	0.2092	0.0392
2700		6.8848	2.2295	0.6120	0.2254	0.0423
2800		7.4189	2.4011	0.6591	0.2422	0.0455
2900		7.9734	2.5793	0.7079	0.2597	0.0488
3000		8.5484	2.7640	0.7585	0.2777	0.0523
3100		9.1441	2.9552	0.8109	0.2963	0.0558
3200		9.7603	3.1529	0.8650	0.3155	0.0595
3300			3.3571	0.9210	0.3353	0.0633
3400			3.5679	0.9787	0.3557	0.0672
3500			3.7853	1.0382	0.3767	0.0712
3600			4.0091	1.0995	0.3983	0.0754
3700			4.2396	1.1626	0.4205	0.0797

Section 7.1 - Table PD-1A

**Pressure drop ("wc per foot) for TracPipe based on a given CFH Flow
Natural Gas SG = 0.60 Gas) at Inlet Pressures up to 5 psig**

Note: For Propane (LP) Gas applications, obtain Pressure Drop per foot values by following the Propane conversion method detailed in Section 7.1 of the TracPipe D&I Guide.

CFH	1"	1-1/4"	1-1/2"	2"	CFH	1-1/2"	2"
3800	4.4766	1.2275	0.4433	0.0841	11000	3.6307	0.7119
3900	4.7202	1.2941	0.4666	0.0886	11500	3.9645	0.7784
4000	4.9704	1.3626	0.4906	0.0932	12000	4.3128	0.8479
4100	5.2271	1.4329	0.5152	0.0979	12500	4.6756	0.9204
4200	5.4905	1.5050	0.5403	0.1028	13000	5.0529	0.9959
4300	5.7604	1.5788	0.5661	0.1078	13500	5.4447	1.0744
4400	6.0370	1.6545	0.5924	0.1129	14000	5.8509	1.1559
4500	6.3202	1.7320	0.6194	0.1181	14500	6.2716	1.2404
4600	6.6100	1.8112	0.6469	0.1234	15000	6.7067	1.3278
4700	6.9064	1.8923	0.6750	0.1289	16000	7.6202	1.5117
4800	7.2094	1.9752	0.7037	0.1344	17000	8.5913	1.7077
4900	7.5191	2.0599	0.7330	0.1401	18000	9.6200	1.9156
5000	7.8355	2.1464	0.7629	0.1459	19000		2.1355
5250	8.6554	2.3706	0.8402	0.1610	20000		2.3674
5500	9.5170	2.6062	0.9212	0.1767	21000		2.6113
5750		2.8531	1.0059	0.1933	22000		2.8673
6000		3.1114	1.0943	0.2105	23000		3.1352
6250		3.3811	1.1864	0.2285	24000		3.4152
6500		3.6623	1.2821	0.2473	25000		3.7073
6750		3.9548	1.3815	0.2667	26000		4.0114
7000		4.2588	1.4846	0.2870	27000		4.3275
7250		4.5743	1.5913	0.3079	28000		4.6557
7500		4.9012	1.7017	0.3297	29000		4.9959
7750		5.2397	1.8158	0.3521	30000		5.3482
8000		5.5896	1.9335	0.3753	31000		5.7126
8250		5.9511	2.0549	0.3993	32000		6.0890
8500		6.3241	2.1799	0.4240	33000		6.4775
8750		6.7086	2.3086	0.4494	34000		6.8781
9000		7.1047	2.4409	0.4756	35000		7.2908
9250		7.5124	2.5769	0.5025	36000		7.7155
9500		7.9316	2.7166	0.5302	37000		8.1523
9750		8.3625	2.8598	0.5586	38000		8.6013
10000		8.8049	3.0067	0.5878	39000		9.0623
10500		9.7247	3.3115	0.6483	40000		9.5354

Section 7.1 - Table PD-2A

**Pressure drop ("wc per foot) for Black Iron based on a given CFH Flow
(Natural Gas SG = 0.60 Gas)**

Note: For Propane (LP) Gas applications, obtain Pressure Drop per foot values by following the Propane conversion method detailed in Section 7.1 of the TracPipe D&I Guide.

CFH	1/2"	3/4"	1"	1-1/4"	1-1/2"	2"	2-1/2"	3"
10	0.0003	0.0001						
20	0.0009	0.0002	0.0001					
30	0.0020	0.0005	0.0002					
40	0.0033	0.0009	0.0003	0.0001				
50	0.0050	0.0013	0.0004	0.0001				
60	0.0071	0.0018	0.0006	0.0001	0.0001			
70	0.0094	0.0024	0.0007	0.0002	0.0001			
80	0.0120	0.0031	0.0009	0.0003	0.0001			
90	0.0149	0.0038	0.0012	0.0003	0.0001			
100	0.0181	0.0046	0.0014	0.0004	0.0002	0.0001		
110	0.0216	0.0055	0.0017	0.0005	0.0002	0.0001		
120	0.0254	0.0065	0.0020	0.0005	0.0003	0.0001		
130	0.0295	0.0075	0.0023	0.0006	0.0003	0.0001		
140	0.0338	0.0086	0.0027	0.0007	0.0003	0.0001		
150	0.0384	0.0098	0.0030	0.0008	0.0004	0.0001		
160	0.0433	0.0110	0.0034	0.0009	0.0004	0.0001	0.0001	
170	0.0484	0.0124	0.0038	0.0010	0.0005	0.0001	0.0001	
180	0.0538	0.0137	0.0043	0.0011	0.0005	0.0002	0.0001	
190	0.0595	0.0152	0.0047	0.0012	0.0006	0.0002	0.0001	
200	0.0654	0.0167	0.0052	0.0014	0.0006	0.0002	0.0001	
225	0.0813	0.0208	0.0064	0.0017	0.0008	0.0002	0.0001	
250	0.0988	0.0252	0.0078	0.0021	0.0010	0.0003	0.0001	
275	0.1178	0.0301	0.0093	0.0025	0.0012	0.0003	0.0001	0.0001
300	0.1384	0.0353	0.0109	0.0029	0.0014	0.0004	0.0002	0.0001
325	0.1605	0.0410	0.0127	0.0034	0.0016	0.0005	0.0002	0.0001
350	0.1840	0.0470	0.0146	0.0038	0.0018	0.0005	0.0002	0.0001
375	0.2091	0.0534	0.0165	0.0044	0.0021	0.0006	0.0003	0.0001
400	0.2356	0.0602	0.0186	0.0049	0.0023	0.0007	0.0003	0.0001
425	0.2635	0.0673	0.0208	0.0055	0.0026	0.0008	0.0003	0.0001
450	0.2929	0.0748	0.0232	0.0061	0.0029	0.0009	0.0004	0.0001
475	0.3237	0.0827	0.0256	0.0068	0.0032	0.0010	0.0004	0.0001
500	0.3559	0.0909	0.0282	0.0074	0.0035	0.0010	0.0004	0.0002
525	0.3896	0.0995	0.0308	0.0081	0.0039	0.0011	0.0005	0.0002
550	0.4246	0.1084	0.0336	0.0089	0.0042	0.0012	0.0005	0.0002
575	0.4609	0.1177	0.0365	0.0096	0.0046	0.0014	0.0006	0.0002
600	0.4987	0.1273	0.0394	0.0104	0.0049	0.0015	0.0006	0.0002
625	0.5378	0.1373	0.0425	0.0112	0.0053	0.0016	0.0007	0.0002
650	0.5783	0.1476	0.0457	0.0121	0.0057	0.0017	0.0007	0.0002
675	0.6201	0.1583	0.0490	0.0130	0.0061	0.0018	0.0008	0.0003

Tables calculated from Low-Pressure Gas Formula in NFPA -54

Section 7.1 - Table PD-2A

**Pressure drop ("wc per foot) for Black Iron based on a given CFH Flow
(Natural Gas SG = 0.60 Gas)**

Note: For Propane (LP) Gas applications, obtain Pressure Drop per foot values by following the Propane conversion method detailed in Section 7.1 of the TracPipe D&I Guide..

CFH	1/2"	3/4"	1"	1-1/4"	1-1/2"	2"	2-1/2"	3"
700	0.6632	0.1693	0.0525	0.0139	0.0066	0.0019	0.0008	0.0003
725	0.7077	0.1807	0.0560	0.0148	0.0070	0.0021	0.0009	0.0003
750	0.7535	0.1924	0.0596	0.0157	0.0074	0.0022	0.0009	0.0003
775	0.8006	0.2044	0.0633	0.0167	0.0079	0.0024	0.0010	0.0003
800	0.8490	0.2168	0.0671	0.0177	0.0084	0.0025	0.0011	0.0004
825	0.8987	0.2295	0.0711	0.0188	0.0089	0.0026	0.0011	0.0004
850	0.9497	0.2425	0.0751	0.0198	0.0094	0.0028	0.0012	0.0004
875	1.0020	0.2559	0.0793	0.0209	0.0099	0.0029	0.0012	0.0004
900	1.0556	0.2695	0.0835	0.0221	0.0104	0.0031	0.0013	0.0005
925	1.1105	0.2835	0.0878	0.0232	0.0110	0.0033	0.0014	0.0005
950	1.1667	0.2979	0.0923	0.0244	0.0115	0.0034	0.0014	0.0005
975	1.2241	0.3125	0.0968	0.0256	0.0121	0.0036	0.0015	0.0005
1000	1.2828	0.3275	0.1015	0.0268	0.0127	0.0038	0.0016	0.0006
1100	1.5300	0.3907	0.1210	0.0320	0.0151	0.0045	0.0019	0.0007
1200	1.7972	0.4589	0.1421	0.0375	0.0178	0.0053	0.0022	0.0008
1300	2.0839	0.5321	0.1648	0.0435	0.0206	0.0061	0.0026	0.0009
1400	2.3901	0.6103	0.1890	0.0499	0.0236	0.0070	0.0030	0.0010
1500	2.7154	0.6933	0.2148	0.0567	0.0268	0.0080	0.0034	0.0012
1600	3.0596	0.7812	0.2420	0.0639	0.0302	0.0090	0.0038	0.0013
1700	3.4226	0.8739	0.2707	0.0715	0.0338	0.0101	0.0042	0.0015
1800	3.8043	0.9714	0.3009	0.0795	0.0376	0.0112	0.0047	0.0016
1900	4.2044	1.0735	0.3325	0.0878	0.0416	0.0124	0.0052	0.0018
2000	4.6228	1.1803	0.3656	0.0966	0.0457	0.0136	0.0057	0.0020
2100	5.0593	1.2918	0.4001	0.1057	0.0500	0.0149	0.0063	0.0022
2200	5.5139	1.4079	0.4361	0.1152	0.0545	0.0162	0.0068	0.0024
2300	5.9864	1.5285	0.4735	0.1251	0.0592	0.0176	0.0074	0.0026
2400	6.4766	1.6537	0.5122	0.1353	0.0640	0.0190	0.0080	0.0028
2500	6.9846	1.7834	0.5524	0.1459	0.0690	0.0205	0.0087	0.0030
2600	7.5100	1.9175	0.5940	0.1569	0.0742	0.0221	0.0093	0.0032
2700	8.0530	2.0562	0.6369	0.1682	0.0796	0.0237	0.0100	0.0035
2800	8.6133	2.1992	0.6812	0.1799	0.0851	0.0253	0.0107	0.0037
2900	9.1908	2.3467	0.7269	0.1920	0.0909	0.0270	0.0114	0.0040
3000	9.7856	2.4986	0.7740	0.2044	0.0967	0.0288	0.0121	0.0042
3100		2.6548	0.8223	0.2172	0.1028	0.0306	0.0129	0.0045
3200		2.8153	0.8721	0.2303	0.1090	0.0324	0.0137	0.0048
3300		2.9802	0.9232	0.2438	0.1154	0.0343	0.0145	0.0050
3400		3.1494	0.9756	0.2577	0.1219	0.0363	0.0153	0.0053
3500		3.3228	1.0293	0.2719	0.1286	0.0382	0.0161	0.0056
3600		3.5005	1.0843	0.2864	0.1355	0.0403	0.0170	0.0059
3700		3.6825	1.1407	0.3013	0.1426	0.0424	0.0179	0.0062
3800		3.8687	1.1984	0.3165	0.1498	0.0445	0.0188	0.0065
3900		4.0591	1.2573	0.3321	0.1571	0.0467	0.0197	0.0069

Tables calculated from Low-Pressure Gas Formula in NFPA -54

Section 7.1 - Table PD-2A

Pressure drop ("wc per foot) for Black Iron based on a given CFH Flow
(Natural Gas SG = 0.60 Gas)

Note: For Propane (LP) Gas applications, obtain Pressure Drop per foot values by following the Propane conversion method detailed in Section 7.1 of the TracPipe D&I Guide..

CFH	3/4"	1"	1-1/4"	1-1/2"	2"	2-1/2"	3"
4000	4.2537	1.3176	0.3480	0.1647	0.0490	0.0207	0.0072
4100	4.4524	1.3792	0.3643	0.1724	0.0513	0.0216	0.0075
4200	4.6554	1.4421	0.3809	0.1802	0.0536	0.0226	0.0079
4300	4.8624	1.5062	0.3978	0.1882	0.0560	0.0236	0.0082
4400	5.0737	1.5716	0.4151	0.1964	0.0584	0.0246	0.0086
4500	5.2890	1.6383	0.4327	0.2048	0.0609	0.0257	0.0090
4600	5.5084	1.7063	0.4507	0.2133	0.0634	0.0268	0.0093
4700	5.7319	1.7755	0.4690	0.2219	0.0660	0.0278	0.0097
4800	5.9595	1.8460	0.4876	0.2307	0.0686	0.0290	0.0101
4900	6.1912	1.9178	0.5066	0.2397	0.0713	0.0301	0.0105
5000	6.4269	1.9908	0.5258	0.2488	0.0740	0.0312	0.0109
5250	7.0338	2.1788	0.5755	0.2723	0.0810	0.0342	0.0119
5500	7.6658	2.3746	0.6272	0.2968	0.0882	0.0372	0.0130
5750	8.3227	2.5780	0.6810	0.3222	0.0958	0.0404	0.0141
6000	9.0043	2.7892	0.7367	0.3486	0.1036	0.0437	0.0152
6250	9.7104	3.0079	0.7945	0.3759	0.1118	0.0472	0.0164
6500		3.2342	0.8543	0.4042	0.1202	0.0507	0.0177
6750		3.4680	0.9160	0.4334	0.1289	0.0544	0.0189
7000		3.7093	0.9798	0.4636	0.1378	0.0582	0.0203
7250		3.9580	1.0455	0.4947	0.1471	0.0621	0.0216
7500		4.2142	1.1131	0.5267	0.1566	0.0661	0.0230
7750		4.4776	1.1827	0.5596	0.1664	0.0702	0.0245
8000		4.7484	1.2542	0.5935	0.1765	0.0745	0.0259
8250		5.0265	1.3277	0.6282	0.1868	0.0788	0.0275
8500		5.3119	1.4031	0.6639	0.1974	0.0833	0.0290
8750		5.6044	1.4803	0.7004	0.2083	0.0879	0.0306
9000		5.9042	1.5595	0.7379	0.2194	0.0926	0.0323
9250		6.2111	1.6406	0.7763	0.2308	0.0974	0.0339
9500		6.5251	1.7235	0.8155	0.2425	0.1023	0.0357
9750		6.8462	1.8083	0.8556	0.2544	0.1074	0.0374
10000		7.1744	1.8950	0.8967	0.2666	0.1125	0.0392
10500		7.8520	2.0740	0.9813	0.2918	0.1231	0.0429
11000		8.5574	2.2603	1.0695	0.3180	0.1342	0.0468
11500		9.2907	2.4540	1.1612	0.3452	0.1457	0.0508
12000			2.6550	1.2563	0.3735	0.1576	0.0549
12500			2.8632	1.3548	0.4028	0.1700	0.0592
13000			3.0786	1.4567	0.4331	0.1828	0.0637
13500			3.3012	1.5620	0.4644	0.1960	0.0683
14000			3.5309	1.6707	0.4967	0.2096	0.0730
14500			3.7676	1.7827	0.5300	0.2237	0.0779
15000			4.0114	1.8981	0.5643	0.2382	0.0830

Tables calculated from Low-Pressure Gas Formula in NFPA -54

Section 7.1 - Table PD-2A

Pressure drop ("wc per foot) for Black Iron based on a given CFH Flow (Natural Gas SG = 0.60 Gas)

Note: For Propane (LP) Gas applications, obtain Pressure Drop per foot values by following the Propane conversion method detailed in Section 7.1 of the TracPipe D&I Guide.

CFH	1-1/4"	1-1/2"	2"	2-1/2"	3"
16000	4.5200	2.1387	0.6359	0.2684	0.0935
17000	5.0563	2.3925	0.7113	0.3002	0.1046
18000	5.6201	2.6593	0.7907	0.3337	0.1163
19000	6.2112	2.9389	0.8738	0.3688	0.1285
20000	6.8293	3.2314	0.9608	0.4055	0.1413
21000	7.4742	3.5366	1.0515	0.4438	0.1546
22000	8.1457	3.8543	1.1460	0.4836	0.1685
23000	8.8437	4.1846	1.2442	0.5251	0.1829
24000	9.5680	4.5273	1.3461	0.5681	0.1979
25000		4.8823	1.4516	0.6126	0.2134
26000		5.2496	1.5608	0.6587	0.2295
27000		5.6292	1.6737	0.7063	0.2461
28000		6.0208	1.7901	0.7555	0.2632
29000		6.4245	1.9102	0.8061	0.2809
30000		6.8403	2.0338	0.8583	0.2990
31000		7.2679	2.1609	0.9120	0.3177
32000		7.7075	2.2916	0.9671	0.3369
33000		8.1589	2.4258	1.0238	0.3567
34000		8.6220	2.5635	1.0819	0.3769
35000		9.0969	2.7047	1.1415	0.3977
36000		9.5834	2.8494	1.2025	0.4189
37000			2.9975	1.2650	0.4407
38000			3.1490	1.3290	0.4630
39000			3.3040	1.3944	0.4858
40000			3.4624	1.4612	0.5091
41000			3.6242	1.5295	0.5329
42000			3.7894	1.5992	0.5572
43000			3.9579	1.6703	0.5819
44000			4.1299	1.7429	0.6072
45000			4.3051	1.8169	0.6330

SECTION 7.2 – SIZING TABLE FOR STEEL PIPE

Natural Gas 0.5 PSI or less / 0.5 inch w.c. drop

SECTION 7.2

Table SP-1

Maximum Capacity of Sch. 40 Metallic Pipe in Cubic Feet of Gas per Hour for Gas Pressures of 0.5 PSI or Less and a Pressure Drop of 0.5 Inch Water Column (Based on a 0.6 Specific Gravity)

Normal Iron Pipe Size (Inches)	Internal Diameter (inches)	Length of Pipe (Feet)															
		10	20	30	40	50	60	70	80	90	100	125	150	175	200		
1/4	.364	43	29	24	20	18	16	15	14	13	12	11	10	9	8		
3/8	.493	95	65	52	45	40	36	33	31	29	27	24	22	20	19		
1/2	.622	175	120	97	82	73	66	61	57	53	50	44	40	37	35		
3/4	.824	360	250	200	170	151	138	125	118	110	103	93	84	77	72		
1	1.049	680	465	375	320	285	260	240	220	205	195	175	160	145	135		
1 1/4	1.380	1,400	950	770	660	580	530	490	460	430	400	360	325	300	280		
1 1/2	1.610	2,100	1,460	1,180	990	900	810	750	690	650	620	550	500	460	430		
2	2.067	3,950	2,750	2,200	1,900	1,680	1,520	1,400	1,300	1,220	1,150	1,020	950	850	800		
2 1/2	2.469	6,300	4,350	3,520	3,000	2,650	2,400	2,250	2,050	1,950	1,850	1,650	1,500	1,370	1,280		
3	3.068	11,000	7,700	6,250	5,300	4,750	4,300	3,900	3,700	3,450	3,250	2,950	2,650	2,450	2,280		
4	4.026	23,000	15,800	12,800	10,900	9,700	8,800	8,100	7,500	7,200	6,700	6,000	5,500	5,000	4,600		

CHAPTER 8

DEFINITION OF TERMINOLOGY

A.G.A. – American Gas Association

ANSI Z223.1 1988 – 1988 edition of the National Fuel Gas Code published by American National Standard Institute. Also known as NFPA 54 (National Fire Protection Association).

Appliance (Equipment) – Any device which utilizes natural gas or propane as a fuel or raw material to produce light, heat, power, refrigeration or air conditioning.

Approved – Acceptable to the authorities having jurisdiction.

Authority Having Jurisdiction – The organization, office or individual responsible for “approving” equipment, an installation or a procedure.

BTU – Abbreviation for British Thermal Unit, which is the quantity of heat required to raise the temperature of one pound of water one degree Fahrenheit .

CFH – Gas flow rate stated in cubic feet per hour.

Clothes Dryer – A device used to dry wet laundry by means of heat derived from the combustion of natural gases.

Design Pressure – The maximum operating pressure permitted by this document, as determined by the design procedures applicable to the materials involved.

Drip Leg – The container (dirt trap pocket) placed at a low point in a system of piping to collect foreign material or condensate and from which it may be removed.

EHD (Effective Hydraulic Diameter) – A relative measure of flow capacity; This number is used to compare individual sizes between different manufacturers. The higher the EHD number the greater flow capacity of the piping.

Full Lockup – The capability of totally stopping the flow of gas if the load goes to zero, thus preventing the downstream pressure from increasing more than a certain upper limit pressure above the set point.

Header (manifold) – A pipe or fitting to which a number of branch lines are connected.

ID – Inside diameter of pipe or tubing.

Inches (") W.C. – Method of stating pressure measured in inches of water column by a manometer or pressure gauge. Commonly used in the gas industry when the pressure is less than one (1) PSI.

1 PSI = 28 in. W.C. approximately

1/2 PSI = 14 in. W.C.

1/4 PSI = 7 in. W.C.

Load – The amount of gas in CFH required by an appliance, or group of appliances, per their rating plate.

L. P. Gas – Fuel gas that is stored and transported in a liquid state, i.e., propane, butane, and mixtures of these and other heavier hydrocarbons.

Meter – An instrument installed to measure the volume of gas delivered through a piping system.

Manometer – A “U” shaped tube filled with water, or mercury where the pressure applied to one leg of the “U” will push the liquid column a measurable distance. Also known as a “U” gauge.

OD – Outside Diameter of pipe or tubing.

1/2 PSI – A shortened way of stating 1/2 pounds per square inch gauge. Also the name of a low pressure piping system supplying gas from the meter at 1/2 PSI to each appliance pressure regulator.

Piping – As used in this document, either pipe or tubing, or both.

a. pipe – Rigid conduit of iron, steel, copper, brass or aluminum.

b. tubing – Semi rigid conduit of corrugated stainless steel.

Pressure – Unless otherwise stated, is expressed in pounds per square inch above atmospheric pressure, i.e. gage pressure (PSI).

Pressure Drop – The loss in static pressure of gas due to friction or obstruction in tubing, valves, fittings, regulators and burners.

Pressure Regulator – A device that reduces and controls pressure. It automatically opens and closes in response to changing pressure conditions in the downstream piping.

PSI – Pounds per square inch gauge. The pressure, as read from a measurement gage or device. Gauge pressure is pressure above atmospheric pressure.

Purge – To displace the original air, or gas, or a mixture of gas and air in a gas conduit with a new air/gas mixture.

Regulator, Appliance (inches w.c. – inches w.c.)
– A device for controlling and maintaining a uniform pressure to the manifold of gas burning equipment. This valve is typically part of the appliance. It reduces the pressure from 5.5" w.c. to the manifold pressure in the appliance. (approximately 3.5" w.c.).

Regulator, Line Gas Pressure (PSI – inches w.c.)
– A device placed in a gas line between the service regulator and the appliance regulator for controlling, maintaining or reducing the pressure in that portion of the piping system downstream of the device. This valve reduces the house line pressure (typically 2 PSI) to the regulator manifold pressure (typically 8-10" w.c.).

Regulator, Service (PSI – PSI or inches w.c.) – A device installed by the serving gas supplier to reduce and limit the service line gas pressure. This valve reduces the service pressure to the metering pressure. It is located upstream of the gas meter.

Regulator Vent – The opening in the atmospheric side of the regulator housing permitting the in and out movement of air to compensate for the movement of the regulator diaphragm.

Specific Gravity – As applied to gas, the ratio of the weight of a given volume to that of the same volume of air, both measured under the same conditions.

2 PSI – A shortened way of stating 2 pounds per square inch gauge pressure. Also the name of a piping system supplying gas at 2 PSI to a line gas pressure regulator which then reduces the pressure to inches W.C. upstream of the appliance regulator.

Valve, Manual Shut-off – A valve (located in the piping system and readily accessible and operable by the consumer) used to shut off individual equipment.

Vent Limiter Device – Restriction/orifice type device in the vent outlet of a pressure regulator that controls or limits leakage, in the event of a diaphragm leak. It also allows the diaphragm to move freely to control pressure.

APPENDIX A UL CLASSIFICATION

System No. W-J-1106

F-Rating - 1 & 2 Hr

T-Rating - 3/4 and 1-1/4 Hr

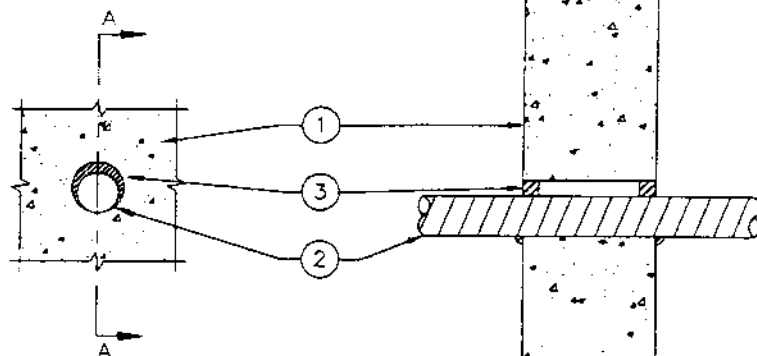

Underwriters Laboratories, Inc.®

SECTION A-A

1. **Wall Assembly**- Min 4-7/8 in. or 6-1/8 in. thick lightweight or normal weight (100-150 pcf) concrete for 1 or 2 hr rated assemblies, respectively. Wall may also be constructed of any UL Classified **Concrete Blocks***. Max diam of opening is 3-1/2 in.

See **Concrete Blocks** (CAZT) category in the Fire Resistance Directory for names of manufacturers.

2. **Through Penetrating Products*-Flexible Metal Piping**-Nom. 2 in. diam (or smaller) steel flexible metallic piping. Max one flexible metal piping to be installed either concentrically or eccentrically within opening. The annular space between piping and periphery of opening shall be min 0 (point contact) in. to max 1 in. Piping to be rigidly supported on both sides of wall assembly. Plastic covering on piping may or may not be removed on both sides of wall assembly.

Omegaflex Inc.—Counterstrike Flexible Gas Piping.

3. **Fill, Void, or Cavity Material*-Sealant** -Min. 5/8 and 1 in. thickness of fill material for 1 and 2 hr fire-rated wall assemblies, respectively, applied within the annulus, flush with both surfaces of wall. An additional 1/2 in. diam of fill material applied at gypsum board/penetrant interface at point contact location on both surfaces of wall.

Johns Manville International, Inc. — Firetemp™ CI

*Bearing the UL Classification Marking

SYSTEM No. C-AJ-1340

Floor or Wall Assembly-Min 4-1/2 in. thick lightweight or normal weight (100 to 150 pcf) concrete. Wall may also be constructed of any UL Classified **Concrete Blocks***. Diam of opening in floor or wall assembly to be min 3/4 in. to max 1-1/2 in. Larger than diam of flexible metal piping (Item 2) installed in through opening. Max diam of opening is 4 in. See Concrete Block (CAZT) category in the Fire Resistance Directory for names of manufacturers.

Through-Penetrant*-Omegaflex Gas Piping-Nom 2 in. diam (or smaller) flexible gas piping. One flexible gas piping to be installed either concentrically or eccentrically within the firestop system. The annular space between gas piping and periphery of opening shall be min 0 in. (point contact) to max. 1-1/2 in. Gas piping to be rigidly supported on both sides of floor or wall assembly. Plastic covering on piping may or may not be removed on both sides of floor or wall assembly. **OmegaFlex, Inc.-CounterStrike** Flexible Gas Piping

Firestop System -The firestop system shall consist of the following:

A. Packing Material-Min 3-3/4 in. thickness of min 4 pcf mineral wool batt insulation firmly packed into opening as a permanent form. Packing material to be recessed from top surface of floor or from both surfaces wall as required to accommodate the required thickness of fill material.

B. Fill, Void or Cavity Material* -Sealant Min 3/4 in. thickness of fill material applied within the annulus, flush with top surface of floor or both surfaces of wall. Min 1/2 in. diam bead of caulk applied to the penetrant/concrete or penetrant/concrete interface at the point contact location between penetrant and periphery of opening.

Passive Fire Protection Partners--4800DW

* Bearing the UL Classification Marking

XHEZ

Through Penetration Firestop systems

System No. C-AJ-1340

F-Rating - 4 Hr

T-Rating - 2 1/4 Hr

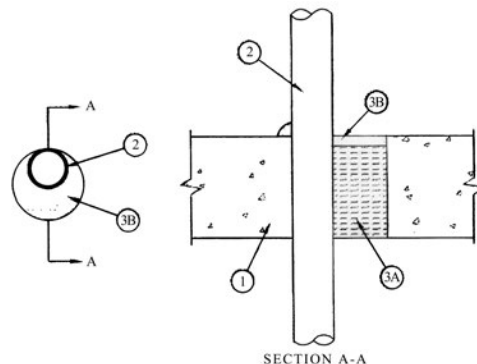

Underwriters Laboratories, Inc.®

UL CLASSIFICATION

SYSTEM NO. W-L-1195

The UL Through Penetration Firestop Systems in Appendix A are only a sample of the complete UL database. See NOTE below.

1. Wall Assembly- The 1 or 2 hr fire rated gypsum wallboard/stud wall assembly shall be constructed of the materials and in the manner described in the individual U300 or U400 Series Wall and Partition Designs in the UL Fire Resistance Directory and shall include the following construction features:

A. Studs- Wall framing may consist of either wood studs or steel channel studs. Wood studs to consist of nom 2 by 4 in. lumber spaced 16 in. OC with nom 2 by 4 in. Lumber end plates and cross braces. Steel studs to be min 3-5/8 in. wide by 1-3/8 in. deep channels spaced max 24 in. OC.

B. Wallboard, Gypsum* - Thickness, type, number of layers and fasteners as required in the individual Wall and Partition Design. Max diam of opening is 3-1/2 in.

XXEZ
Through-Penetration Firestop Systems
System No. W-L-1195
F Rating - 1 & 2 hr (See Item 1)
T Rating - 3/4 & 1-1/4 hr(See Item 1)

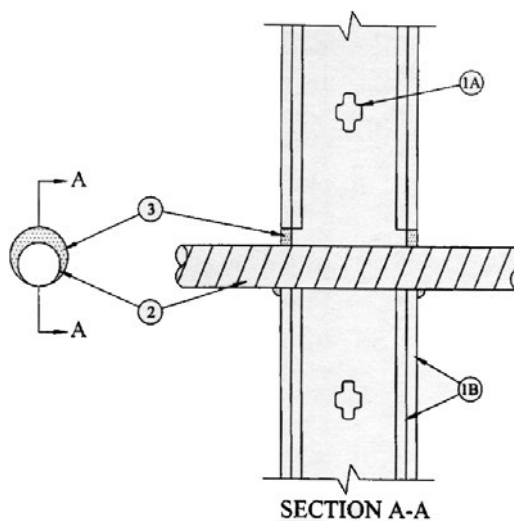

Underwriters Laboratories inc.®

1. The hourly F rating of the firestop system is equal to the hourly fire rating of the wall assembly in which it is installed. The hourly T rating is 3/4 hr and 1-1/4 hr for 1 and 2 hr rated assemblies, respectively.

2. Through-Penetrating Product*-Flexible Metal Piping-Nom 2 in. diam (or smaller) steel Flexible Metal Piping. Max one flexible metal piping to be installed either concentrically or eccentrically within opening. The annular space between pipe and periphery of opening shall be min 0 in. (point contact)to max 1 in. Piping to be rigidly supported on both sides of wall assembly. Plastic covering on piping may or may not be removed for a distance of 2 ft. on both sides of wall assembly. **OmegaFlex, Inc.- CounterStrike Flexible Gas Piping.**

3. Fill, Void, or Cavity Material*-Sealant - Min 5/8 and 1 in. thickness of fill material for 1 and 2 hr fire-rated wall assemblies, respectively, applied within the annulus, flush with both surfaces of wall. An additional 1/2 in diameter of fill material applied at gypsum board/penetrant interface at point contact location on both surfaces of wall.

Johns Manville International, Inc. - Firetemp™CI

*Bearing the UL Classification Marking

NOTICE: to access the complete UL Through Penetration Firestop Systems database online:

1. Go to website www.ul.com
2. Click on : "CERTIFICATIONS" in left hand panel
3. Click on : "Company name/location" under General Search
4. Fill in OmegaFlex inc (3 words) in "Company Name" box
5. All approved systems are shown

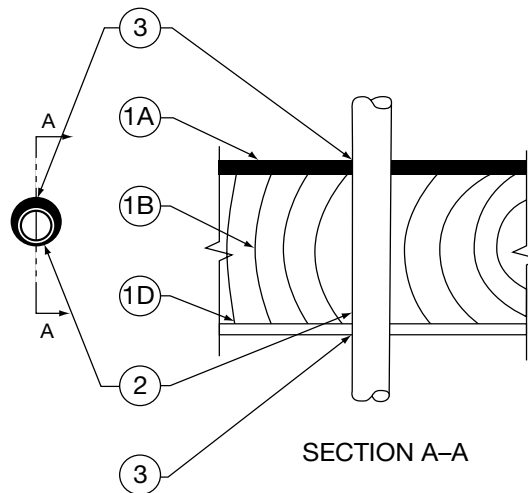

1. **Floor Assembly** - The 1 or 2 hr fire-rated wood joist, wood truss or combination wood and steel truss Floor-Ceiling assembly shall be constructed of the materials and in the manner described in the individual L500 Series Design in the UL Fire Resistance Directory. **The F Rating of the firestop system is equal to the rating of the floor-ceiling and wall assemblies.** The general construction features of the floor-ceiling assembly are summarized below:
 - A. **Flooring System** - Lumber or plywood subfloor with finish floor of lumber, plywood or Floor **Topping Mixture*** as specified in the individual Floor-Ceiling Design. Max diam of opening is 3 in. (76 mm).
 - B. **Joists** - Nom 2 by 10 in. (51 by 254 mm) deep (or deeper) lumber joists spaced 16 in. (406 mm) OC or steel or combination lumber and steel joists, trusses or **Structural Wood Members*** with bridging as required and with ends firestopped.
 - C. **Furring Channels** (Not Shown) (As required) Resilient galvanized steel furring installed in accordance with the manner specified in the individual L500 Series Designs in the Fire Resistance Directory.
 - D. **Gypsum Board*** - Thickness, type, number of layers and fasteners shall be as specified in the individual Floor-Ceiling Design. Max diam of opening is 3 in. (76 mm).
2. **Through Penetrating Products* - Flexible Metal Piping**-Nom 2 in. (51 mm) diam (or smaller) steel Flexible Metal Piping with or without plastic covering on piping. Max one flexible metal piping to be installed near center of circular through opening in floor assembly. The annular space between the piping and periphery of opening shall be min 0 in. (0 mm) (point contact) to max 1/2 in. (13 mm). Piping to be rigidly supported on both sides of floor assembly.
3. **Fill, Void or Cavity Material* - Sealant** - Min 3/4 in. (19 mm) thickness of sealant applied within annulus on top surface of floor. Min 5/8 in. (16 mm) thickness of sealant applied within annulus on bottom surface of ceiling. At point contact location, a min 1/2 in. (13 mm) bead of sealant shall be applied to the penetrant/gypsum board interface on bottom surface of ceiling and at penetrant/flooring interface on top surface of floor.

Passive Fire Protection Partners** - 3600EX, 41GONS or 4800DW

*Bearing the UL Classification Marking

**Formerly Firestop Systems Inc.

APPENDIX B MANUFACTURED HOUSING GUIDELINES

A. CODE AND ADMINISTRATIVE REQUIREMENTS

1. Manufactured homes and mobile homes bearing an insignia or required to bear an insignia must comply with Title VI 24 Code of Federal Regulations, The National Manufactured Housing Act of 1974 Part 3280. In most jurisdictions this requirement remains in force *when the structural, electrical plumbing or mechanical systems are altered*. The Code of Federal Regulations, Housing and Urban Development, Part 3280 *Manufactured Home Construction and Safety Standards* is applicable throughout the USA for manufactured housing construction (also known as “HUD code” housing).
2. There are other types of factory-built housing that do not fall directly under the classification “HUD code” which must also be reviewed for special installation considerations when designing a CSST gas piping system or appliance retrofit. Some examples of this type of housing are Assembly Buildings, Panelized, Modular, and Production Build. **TracPipe® CounterStrike®** should not be considered for RVs, which are subject to over the road use and not just initial placement or repositioning.
3. Part 3280 *Manufactured Home Construction and Safety Standards 1994* has not been revised or updated for several years. There has been an effort by both NFPA and CABO (now a part of the ICC) to have the US Congress adopt a new Manufactured Housing Code. The latest version of the CABO Code *ICC/ANSI 2.0 Manufactured Housing Construction Safety Standards* is available but has not been adopted by Congress.
4. Omegaflex has obtained a written opinion from the U.S. Department of Housing and Urban Development regarding the use of **TracPipe® CounterStrike®** CSST. This HUD decision states “CSST, such as **TracPipe® CounterStrike®**, is allowed to be used in HUD manufactured homes (based upon incorporation of *NFPA 54-1992 ANSI 223.1 The National Fuel Gas Code* into Section 3280.703 Minimum Standards).” This opinion shall be confirmed with State authorities responsible for inspections of HUD Code buildings prior to installing **TracPipe® CounterStrike®** after the home has left the factory. For factory installations, approval by the DAPIA (Manufacturer’s Design Approval Primary Inspection Agency) is normally required for the piping system design. Contact Omegaflex for specification data and a copy of the HUD decision letter.

B. PIPING SYSTEM DESIGN REQUIREMENTS

1. The primary information for any **TracPipe® CounterStrike®** installation is contained in the **TracPipe® CounterStrike® Design Guide and Installation Instructions** (latest edition). This guide provides manufacturer’s instructions that are a requirement of the ANSI/CSA LC-1 Standard governing certification and test requirements for Corrugated Stainless Steel Tubing. Manufacturer’s instructions must be followed.

APPENDIX B MANUFACTURED HOUSING GUIDELINES

A. CODE AND ADMINISTRATIVE REQUIREMENTS

1. Manufactured homes and mobile homes bearing an insignia or required to bear an insignia must comply with Title VI 24 Code of Federal Regulations, The National Manufactured Housing Act of 1974 Part 3280. In most jurisdictions this requirement remains in force *when the structural, electrical plumbing or mechanical systems are altered*. The Code of Federal Regulations, Housing and Urban Development, Part 3280 *Manufactured Home Construction and Safety Standards* is applicable throughout the USA for manufactured housing construction (also known as “HUD code” housing).
2. There are other types of factory-built housing that do not fall directly under the classification “HUD code” which must also be reviewed for special installation considerations when designing a CSST gas piping system or appliance retrofit. Some examples of this type of housing are Assembly Buildings, Panelized, Modular, and Production Build. **TracPipe® CounterStrike®** should not be considered for RVs, which are subject to over the road use and not just initial placement or repositioning.
3. Part 3280 *Manufactured Home Construction and Safety Standards 1994* has not been revised or updated for several years. There has been an effort by both NFPA and CABO (now a part of the ICC) to have the US Congress adopt a new Manufactured Housing Code. The latest version of the CABO Code *ICC/ANSI 2.0 Manufactured Housing Construction Safety Standards* is available but has not been adopted by Congress.
4. Omegaflex has obtained a written opinion from the U.S. Department of Housing and Urban Development regarding the use of **TracPipe® CounterStrike®** CSST. This HUD decision states “CSST, such as **TracPipe® CounterStrike®**, is allowed to be used in

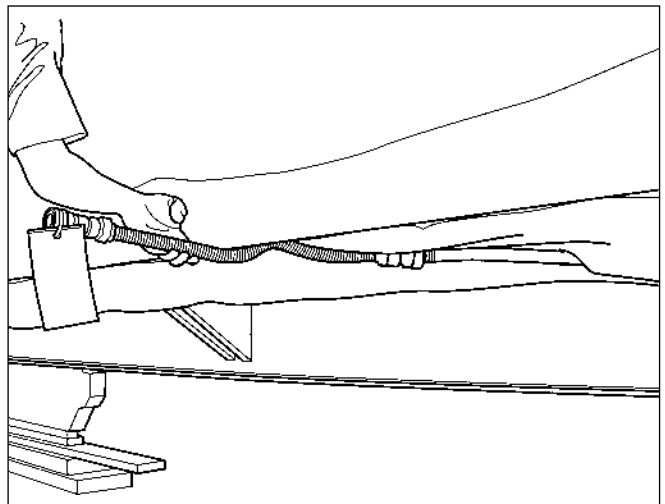
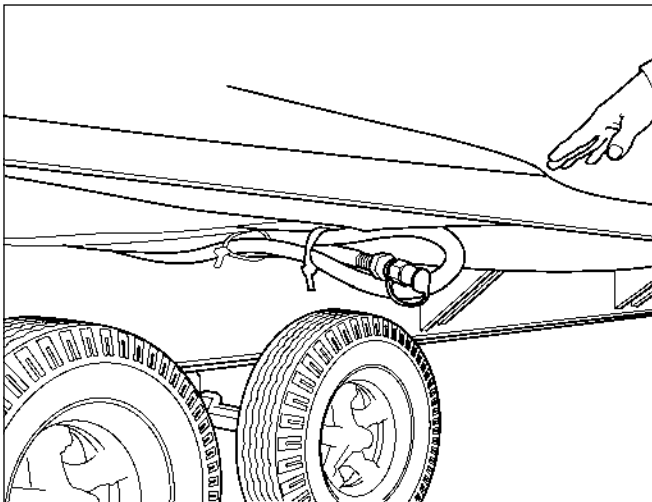

HUD manufactured homes (based upon incorporation of *NFPA 54-1992 ANSI 223.1 The National Fuel Gas Code* into Section 3280.703 Minimum Standards).” This opinion shall be confirmed with State authorities responsible for inspections of HUD Code buildings prior to installing **TracPipe® CounterStrike®** after the home has left the factory. For factory installations, approval by the DAPIA (Manufacturer’s Design Approval Primary Inspection Agency) is normally required for the piping system design. Contact Omegaflex for specification data and a copy of the HUD decision letter.

B. PIPING SYSTEM DESIGN REQUIREMENTS

1. The primary information for any **TracPipe® CounterStrike®** installation is contained in the **TracPipe® CounterStrike® Design Guide and Installation Instructions** (latest edition). This guide provides manufacturer’s instructions that are a requirement of the ANSI/CSA LC-1 Standard governing certification and test requirements for Corrugated Stainless Steel Tubing. Manufacturer’s instructions must be followed.
2. Sizing for gas piping systems in HUD Code homes must be performed in accordance with Part 3280 (Natural Gas piping system acceptable for LP-gas). System sizing is to be done with Low Pressure Capacity Charts utilizing 0.5-inch water column drop. (See Chart N-1 in the **TracPipe® CounterStrike® Design Guide**).
3. The natural gas supply connections shall not be less than the size of the gas piping but shall not be smaller than 3/4-inch nominal pipe size. Gas supply connection shall not be

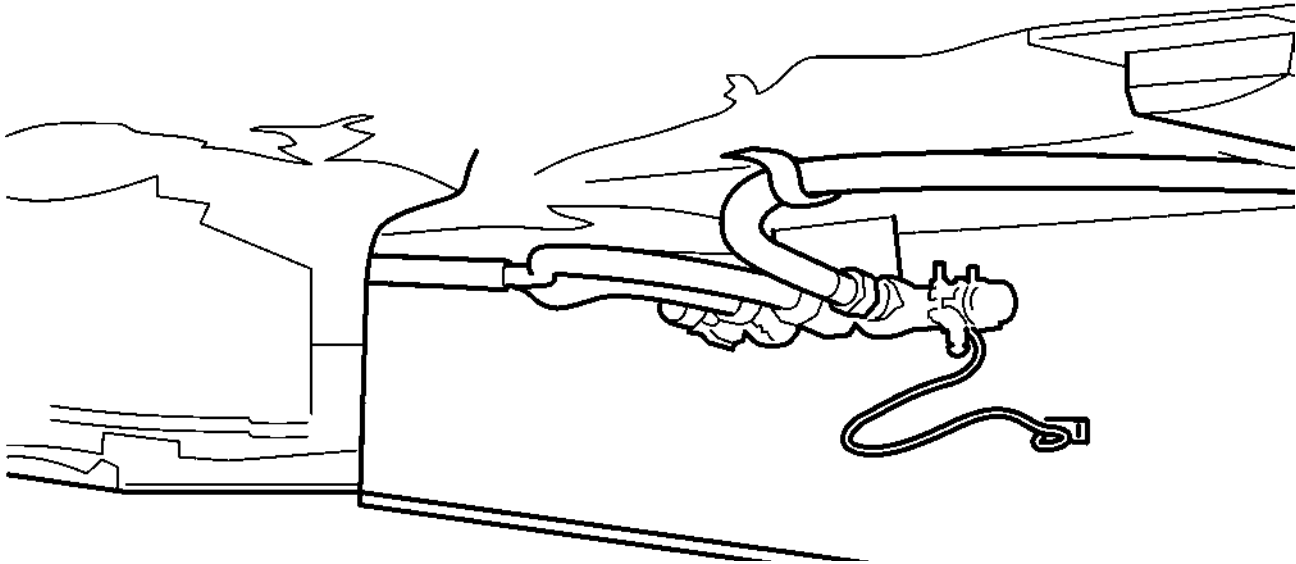

beneath an exit door. Gas supply connection shall be rigidly anchored to a structural member within 6 inches of supply connection. All exterior openings around piping shall be sealed to resist the entrance of rodents.

4. Where fuel gas piping is to be installed in more than one section of an expandable or multiple-unit home, crossover connections between sections of the home shall be constructed by one of the following methods:
 - A. Listed quick disconnect device, designed to provide a positive seal of the supply side of the gas piping system when such device is separated.
 - B. Flexible connectors listed for exterior use and a shutoff valve of the non-displaceable rotor type conforming to ANSI Z21.15, installed on supply side.
 - C. Direct plumbing (CSST) sized in accordance with Natural Gas Low Pressure Capacity Chart N-1 in Chapter & of this installation guide.

5. The flexible connector, direct plumbing pipe or “quick-disconnect” device shall be provided with protection from mechanical and impact damage and located to minimize the possibility of tampering. For gas line crossover connections made with CSST or flexible connectors, the crossover points shall be capped on the supply side to provide a positive seal and covered on the other side with a suitable protective covering.
6. All points of crossover shall be accessible from the exterior of the home.

C. INSTALLATION REQUIREMENTS

1. The preferred location for CSST flexible gas piping is beneath the floor and inside or above the I-beam flange. This location will provide the best protection from transit damage. Appliance stub-outs are easily made utilizing termination mounts or flange mounts rigidly attached to the floor. Final connections can be made with approved flexible appliance connectors downstream from the appliance shut-off valve. All floor penetrations shall be sealed to resist the entrance of rodents. All CSST should be within the envelope or rigidly attached to the I-beam flange.
2. Where CSST must cross an I-beam flange, the piping shall be securely attached to the house flange to protect the CSST. Angle iron, C-channel or a wooden block are recommended means of attachment. It is preferred to drill through a wooden structural member if possible to avoid crossing the flange.
3. In open joist construction, routing should be within the open web portion of the fabricated joist wherever possible. This location provides necessary support points at each joist location.
4. In all locations, CSST must be supported in accordance with the manufacturer’s instructions (every 4 feet-3/8 size, 6 feet-1/2 size, 8 feet-3/4 size and 1 inch size) Support should be with metal EMT conduit straps or two-point attachment plastic clips suitable for the size of the tubing.
5. If a manifold is used, it shall be rigidly mounted to the I-beam flange. This applies to parallel system layouts. Gas pressure in HUD Code homes is limited to 14 inches water column maximum. Line pressure regulators are not necessary for this pressure and should not be used.
6. The gas piping shall be bonded to the frame of the home by the use of:
 - a. Solderless type grounding terminal with a star washer bolted to the chassis;
 - b. Grounding clamp attached to a gas piping fitting. (For attachment of clamp to **TracPipe® AutoFlare®** fitting, refer to Section 4.10 – Electrical Bonding/Grounding. Do not attach clamp to the stainless steel portion under any circumstances.); and
 - c. Bonding electrode conductor sizing shall be in accordance with NFPA 70 Article 250 Section and Table 250-66.

7. Concealed tubing: CSST shall not be run inside walls, partitions or roofs. Where tubing passes through walls, floors, partitions, roofs, or similar installations, such tubing shall be protected by the use of weather resistant grommets that shall snugly fit both the tubing and the hole through which the tubing passes. DO NOT remove the yellow polyethylene jacket in any penetrations.
8. All CSST tubing joints shall have any exposed sections of stainless steel piping wrapped with silicone self-bonding tape. The under-floor portion of the manufactured home is considered an outdoor location. Proper support (per item 4 above) is required under the floor.
9. Retrofit of appliances:
 - a. The gas supply connection shall be rigidly anchored to a structural member within 6 inches of supply connection.
 - b. CSST shall be supported and protected per manufacturer's instructions. (See items 4 and 7 above.)
 - c. Pressure test gas piping per Item D 1 below before operating appliance.

D. INSPECTION AND TEST REQUIREMENTS

1. Pressure test in accordance with Part 3280.705k (8) testing for leakage (8 i) before appliances are connected and (8 ii) after appliances are connected.

APPENDIX C

SECTION C1.1 - AUTOTRIP® LOW PRESSURE EXCESS FLOW VALVES FOR NATURAL GAS AND PROPANE SERVICE

An excess flow valve (EFV) is a protective device to help control the discharge of fuel gas in the event of a complete breakage of pipe lines or flex connector rupture. Excess flow valves have been of help in limiting gas loss in many incidents involving breakage of piping; thus they do provide a useful safety function in gas systems. This section explains what protection excess flow valves can offer, points out conditions which can interfere with that protection, and offers suggestions for effective excess flow valve installation.

1. There are two types of **AutoTrip®** EFVs: LFD Series Line/Meter excess flow valves and AFD Series Appliance Connector excess flow valves.

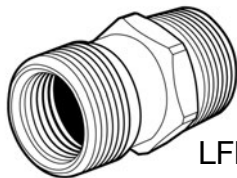

LFD Series

A. **AutoTrip® LFD Line/Meter Excess Flow Valves (EFVs)** protect against potential damage due to the release of fuel gas as a result of residential and commercial gas line breaks. **AutoTrip®** excess flow valves work in conjunction with all approved gas piping materials (**TracPipe® CounterStrike®**, other brands of CSST, steel pipe, and copper tube) at the gas meter, second stage regulator, the appliance branch line or manifold connection.

B. **AutoTrip® AFD Appliance Connector Excess Flow Valves** protect against potential damage due to the release of fuel gas when a flexible gas appliance connector line breaks.

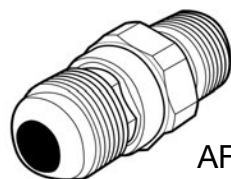

AFD Series

AutoTrip® Appliance Connector EFVs act to restrict the flow of gas should the downstream appliance connector suffer a complete break or pull-out. The inlet side of the **AutoTrip®** Appliance Connector excess flow valve adapts to all approved gas piping materials (**TracPipe® CounterStrike®**, other brands of CSST, steel pipe, and copper tube) with an NPT connection. The Outlet side comes equipped with an SAE flare for connection to standard appliance connectors.

2. Quality Assurance

- **AutoTrip®** valves are Design-Certified by CSA International and manufactured and 100% factory tested in accordance with the IAS U.S. Requirements 3-92 for Excess Flow Valves.
- Listed by IAPMO File 5031-International Association of Plumbing and Mechanical Officials.
- Listed by CA-DSEA-California Division of State Architect.

3. IMPORTANT NOTES and LIMITATIONS Regarding the Use of Excess Flow Valves

Installation of the **AutoTrip®** excess flow valve must only be performed by a qualified plumber or gas fitter who meets state and/or local requirements to perform work on fuel gas piping systems. The **AutoTrip®** valve must be installed in compliance with local codes or, in the absence of local codes, with the National Fuel Gas Code ANSI Z223.1/NFPA 54, The International Fuel Gas Code, or The Uniform Plumbing Code.

IMPORTANT

1. Read all installation instructions and limitations before installing.
2. Size the excess flow valve to match the gas demand for appliances installed. See sizing instructions below. DO NOT OVERSIZE the valve for anticipated appliance additions.
3. Prior to installing, TURN OFF gas supply using an upstream shut-off valve.
4. Install the excess flow valve with the proper flow direction as marked on the label and in the correct position (vertical up only for LFD models) and (multipoise [any position] for AFD models) as specified in these instructions.
5. After installation is complete, pressurize system by opening gas supply shut off valve VERY SLOWLY to initiate gas service.
6. Check all connections with a non-corrosive leak detector solution to assure connections are leak tight. (Available: TracPipe Leak Check Solution P/N FGP-LCS).

4. LIMITATIONS OF AUTOTRIP® EXCESS FLOW VALVES FOR NATURAL GAS AND PROPANE SYSTEMS

AutoTrip® excess flow valves are designed to protect against complete breakage of gas lines DOWNSTREAM of the location of which the **AutoTrip®** excess flow valve is installed. **AutoTrip®** excess flow valves installed at the Meter are designed only to protect the main trunk line piping of like size of which it was installed. These devices may not protect against gas piping breaks at a given length downstream from the EFV or after a reduction in pipe size. Additional factors that may affect the proper function of an EFV:

1. The system was not sized properly to allow the EFV to close upon complete breakage of a gas line
2. The system was not sized properly with the EFV to allow proper operation of all appliances
3. The supply pressure is not great enough to provide the required capacity
4. Restrictions exist in the gas piping system that prevent proper operation of the EFV such as, but not limited to, reductions in pipe size, incomplete or partial breaks of gas lines, partially open or smaller than full-bore valves or components in the gas piping system, any additional restrictions that would prevent the required capacity of gas to escape from the system that would close the valve.
5. Foreign matter, such as pipe thread sealant, is lodged in valve, preventing closure.
6. The excess flow valve has been damaged by fire or improper installation and is no longer in operating condition. **NOTICE:** If the valve is not in operating condition, IT MUST BE REPLACED.

SECTION C1.2 - AUTOTRIP LFD SERIES EXCESS FLOW VALVES FOR METER AND BRANCH LINE/MANIFOLD APPLICATIONS

LFD SERIES PRODUCT SPECIFICATIONS

Material Specification:

Body	Brass Nickel Plated
Seat & Retainer	Polyamide
Valve Float / Ball	POM or PTFE
<u>Operating Temperature:</u>	-20°F to 150°F
<u>Operating Pressure:</u>	0.18 PSI (5"wc) to 2 PSI
<u>Maximum Bypass Flow:</u>	10 CFH (Air equivalent)

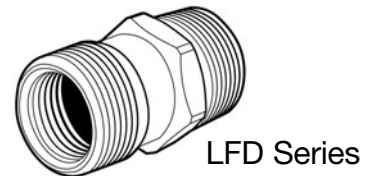

For additional product information including Model Numbers, inlet/outlet thread connections, Maximum load capacity and flow rates, & application please reference Table C.1.

C1.2.1 - APPLICATION, AND SELECTION OF AUTOTRIP® LFD SERIES EXCESS FLOW VALVES

1. Application. Determine the Type of EFV based on the application (Ref. Figure: 3.10).
 - a) Meter
 - b) Branch Line
2. EFV Model Selection. From TABLE: C.1, select the appropriate **AutoTrip®** LFD Series EFV(s) based on the TOTAL BTU/hr load capacity of the appliance(s) it serves. For a Meter application, this is the TOTAL BTU/hr load capacity of ALL the appliance(s) served by the gas meter. For a Branch Line application, this is the BTU/hr load capacity of the appliance(s) on the branch for which the **AutoTrip®**

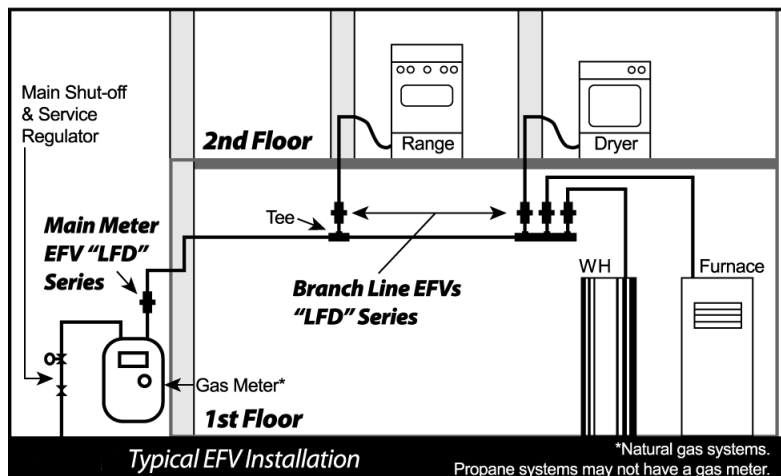

FIGURE: C-1

EFV is installed. The TOTAL BTU/hr load capacity of the appliance(s) should be equal to or less than the Maximum Load Capacity (BTU/hr) value of the **AutoTrip®** LFD Series EFV selected from TABLE: C.1.

TABLE: C.1

AutoTrip® LFD Series Excess Flow Valves Application Data

EFV Type - Application	OmegaFlex AutoTrip P/N	Mounting Position	Inlet Thread Connection(s)	Outlet Thread Connection(s)	Maximum Load Capacity (BTU/hr)	Nominal Closure Flow Rate (SCFH)
Appliance Branch Line	FGP-LFD-70	Vertical Up ONLY	3/4" M-NPT & 1/2" F-NPT	3/4" M-NPT & 1/2" F-NPT	70,000	97
Appliance Branch Line	FGP-LFD-125	Vertical Up ONLY	3/4" M-NPT & 1/2" F-NPT	3/4" M-NPT & 1/2" F-NPT	125,000	147
Meter / Branch Line	FGP-LFD-275A	Vertical Up ONLY	3/4" M-NPT & 1/2" F-NPT	3/4" M-NPT & 1/2" F-NPT	275,000	335
Meter / Branch Line	FGP-LFD-275B	Vertical Up ONLY	1" M-NPT & 3/4" F-NPT	1" M-NPT & 3/4" F-NPT	275,000	335
Meter / Branch Line	FGP-LFD-375	Vertical Up ONLY	1" M-NPT & 3/4" F-NPT	1" M-NPT & 3/4" F-NPT	375,000	460
Meter / Branch Line	FGP-LFD-500	Vertical Up ONLY	1 1/4" M-NPT & 1" F-NPT	1 1/4" M-NPT & 1" F-NPT	500,000	685

Notes:

- 1) Flow Rates given for 0.60 Specific Gravity Natural Gas with an Avg. Heating Value of 1000 BTU / cubic foot.
- 2) To convert Maximum Load Capacity value to BTU/hr Propane (1.52 Specific Gravity, 2520 BTU / cubic foot), multiply Natural Gas Value by 1.583.
- 3) To convert SCFH Nominal Closure Flow Rate to SCFH Propane, multiply Natural gas Value above by 0.628
- 4) Abbreviations: w.c. = inches water column.
SCFH = Standard Cubic Feet per Hour.

C1.2.2 - GAS PIPING SYSTEM SIZING WITH LFD SERIES EXCESS FLOW VALVES

AutoTrip[®] LFD Series excess flow valves must be sized properly for the gas piping system in which they are installed. When installing **AutoTrip**[®] excess flow valves within a fuel gas piping system, the user must assure that:

1. The **AutoTrip**[®] LFD Series EFV will close upon a complete breakage or rupture of gas piping at an expected length downstream of the EFV. It is recommended that the installer conduct tests on the gas piping system to ensure the EFV(s) will function as intended. **Note:** Tests should be performed in accordance with all applicable local and national codes.
2. The addition of the **AutoTrip**[®] LFD Series EFV will allow all appliances to which the EFV serves to operate properly without the undue loss of pressure. It is recommended that the installer run all appliances with the EFV(s) installed to assure proper operation.

C1.2.3 - METHODS OF SIZING

STANDARD SIZING METHOD - When sizing a gas piping system including **AutoTrip**[®] LFD Series EFVs, size the gas piping system using the following Tables: (N-1AT, N-3AT, N-5AT, SP-1AT, P-1AT) using standard methods of gas pipe sizing – Branch Length or Longest Run Method.

ALTERNATE SIZING METHOD – If using an Engineered Method, i.e. “Sum of Pressures Method” of gas pipe sizing, use the pressure drop values in Figure C-3 in your gas piping calculations.

C1.2.4 - SIZING INSTRUCTIONS FOR AUTOTRIP LFD SERIES EFVS USED WITH COUNTERSTRIKE[®] CSST SYSTEMS

- A. Meter Applications (LFD Series LFD 275A, LFD-275B, LFD-375, LFD-500)
 1. Choose the appropriate **AutoTrip**[®] LFD Series Meter EFV using TABLE C.1 based on the total capacity of the gas piping system served by that meter.
 2. Using the appropriate **AutoTrip**[®] Capacity Chart “Table N-1AT **AutoTrip**[®] Low Pressure” or “Table N-5AT **AutoTrip**[®] (2-PSI system)” based upon system pressure; determine the size of CSST based on the **AutoTrip**[®] EFV selected in Step 1 and the appropriate sizing length. This size of CSST is designed to allow the **AutoTrip**[®] EFV to act as a safety shut-off valve in the event of a complete breakage of the main trunk line piping.
- B. Branch Line/Manifold Applications (LFD Series LFD-70, LFD-125, LFD-275A, LFD-275B, LFD-375, and LFD-500):
 1. Elevated Pressure 2 PSI system. (Manifold with parallel arrangement).
 - a. Choose the appropriate size **AutoTrip**[®] LFD Series Appliance Branch Line EFV using TABLE: 3.1 based on the capacity for each manifold outlet. Select an EFV with sufficient capacity to supply the appliance(s) connected to the outlet.
 - b. Using **AutoTrip**[®] Capacity Chart “TABLE: N-3AT **AutoTrip**[®] Dual Pressure System” determine size of **CounterStrike**[®] CSST based on the **AutoTrip**[®] EFV selected in Step a and the appropriate sizing length from the manifold to the appliance(s). This size of CSST is designed to allow the **AutoTrip**[®] EFV to act as a safety shut-off valve in the event of the complete breakage of the downstream branch pipe line or flex connector rupture.

2. Series System Low Pressure
 - a. When there is no manifold, the EFV should be located at the tee or fitting where the appliance drop attaches to the trunk line. If this is a concealed location, follow local codes.
 - b. Choose the appropriate size **AutoTrip**[®] LFD Series Appliance Branch Line EFV using TABLE C.1 based on the capacity for that branch line. Select an EFV with sufficient capacity to supply the appliance(s) connected to that drop.
 - c. Using **AutoTrip**[®] Capacity Chart “Table N-1AT **AutoTrip**[®] Low Pressure” determine size of **CounterStrike**[®] CSST based on the **AutoTrip**[®] EFV selected in Step b and the appropriate sizing length from the appliance back to the meter. This size of CSST is designed to allow the **AutoTrip**[®] EFV to act as a safety shut-off valve in the event of a complete breakage of the downstream branch pipe line or flex connector rupture.

C1.2.5 - SIZING INSTRUCTIONS FOR AUTOTRIP LFD SERIES EFVS USED WITH LOW PRESSURE STEEL PIPE SYSTEMS

1. Choose the **AutoTrip**[®] LFD Series EFV (Appliance branch line or Meter) using TABLE: C.1 which will supply the necessary capacity of the meter or appliance(s) it serves.
2. Using **AutoTrip**[®] Capacity Chart “Table SP-1AT **AutoTrip**[®] Steel Pipe Low Pressure” determine the size of steel pipe based on the **AutoTrip**[®] EFV selected in Step 1 and the appropriate sizing length. This size of steel pipe is designed to allow the **AutoTrip**[®] EFV to act as a safety shut-off valve in the event of a complete breakage of the main trunk line piping (Meter EFV) or of the downstream branch pipe line or flex connector rupture (Appliance Branch Line EFV).

C1.2.6 - LFD INSTALLATION INSTRUCTIONS

- A. Installation of **AutoTrip**[®] LFD Series Meter Application excess flow valves downstream of the Gas Meter Outlet.

The **AutoTrip**[®] device can be installed downstream of the gas company meter and bypass tee outlet using standard pipe fittings and procedures. **AutoTrip** Meter Valves-LFD models must be installed within 5 degrees of the vertical position with the flow arrow pointing upward in the direction of flow. **NOTICE:** EFVs installed at the Meter are designed only to protect the main trunk line of like pipe size downstream of the EFV.

- B. Installation of **AutoTrip**[®] LFD Series Branch Line excess flow valves at the Tee or Manifold connection of a Branch Line to an Appliance.

AutoTrip[®] Branch Line excess flow valves should be connected directly to the manifold outlet at the point between the manifold and the gas appliance lines. If there is no manifold, the valves could be located at the tee or fitting where the appliance drop attaches to the trunk line. **AutoTrip**[®] Branch Line excess flow valves must be installed in the vertical position (within 5 degrees) with the flow arrow pointing upward in the direction of flow.

- C. **Step-by-Step Installation Instructions**
 1. Prior to installing the **AutoTrip**[®] excess flow valve (EFV), turn gas supply off upstream of the EFV using appropriate shut-off valve. For a Meter EFV installation, this will be the main gas company shut-off valve.
 2. Install **AutoTrip**[®] EFV into piping system at desired location using appropriate pipe fittings and tools. When using a thread sealant on pipe threads, do not allow the sealant, Teflon tape or any debris to enter the valve. Foreign matter can lodge in the valve and prevent proper operation.

3. After **AutoTrip**® EFV is installed, insure all connections in the gas piping system are gas tight.
4. Re-open upstream shut-off valve SLOWLY to re-pressurize the system. **NOTICE:** If upstream shut-off valve is opened too quickly and an excess flow condition is created due to a pressure surge the **AutoTrip**® EFV may trip (close). If this occurs, reset the valve using the Resetting an **AutoTrip**® EFV instructions below.
5. **Resetting an AutoTrip® EFV that has “tripped” (closed).** Turn gas supply off upstream of the EFV using appropriate shut-off valve. For a Meter EFV installation, this will be the main gas company shut-off valve. Repair all damaged piping as required. Reset the **AutoTrip**® EFV by closing and sealing off all downstream connections.

Once the pressure in the upstream and downstream piping is equalized, the EFV will reset. This is evident by a “soft click” that can be heard from the **AutoTrip**® EFV. Typical time to reset is 1-2 minutes or of greater duration for larger diameter and/or longer lengths of downstream piping. Repeat Step 4. above to re-pressurize the system.

NOTICE: If there are any open connections (assure all appliance valves are shut) or leaks downstream of the **AutoTrip**® EFV, the EFV will not reset!

CAUTION: Installer must assure at all times that any gas that may have escaped from the gas piping system as a result of a pipe break, valve testing, leakage, etc. is completely dissipated prior to opening appliance shut-offs and firing of appliances. Assure that there is no electrical or motorized equipment in use during this process.

SECTION C1.3 - AUTOTRIP AFD SERIES EXCESS FLOW VALVES FOR APPLIANCE CONNECTOR INLET APPLICATIONS

AFD SERIES PRODUCT SPECIFICATIONS

Material Specification:

Body	Brass Nickel Plated
Seat	Polyamide
Valve Float	Polyamide
Spring	Stainless Steel
<u>Operating Temperature:</u>	32°F to 150°F
<u>Operating Pressure:</u>	0.18 PSI (5"wc) to 1/2 PSI
<u>Maximum Bypass Flow:</u>	10 CFH (Air equivalent)

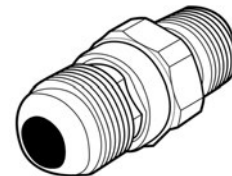

For additional product information including Model Numbers, inlet/outlet thread connections, Maximum load capacity and flow rates, & application please reference Table: C.2.

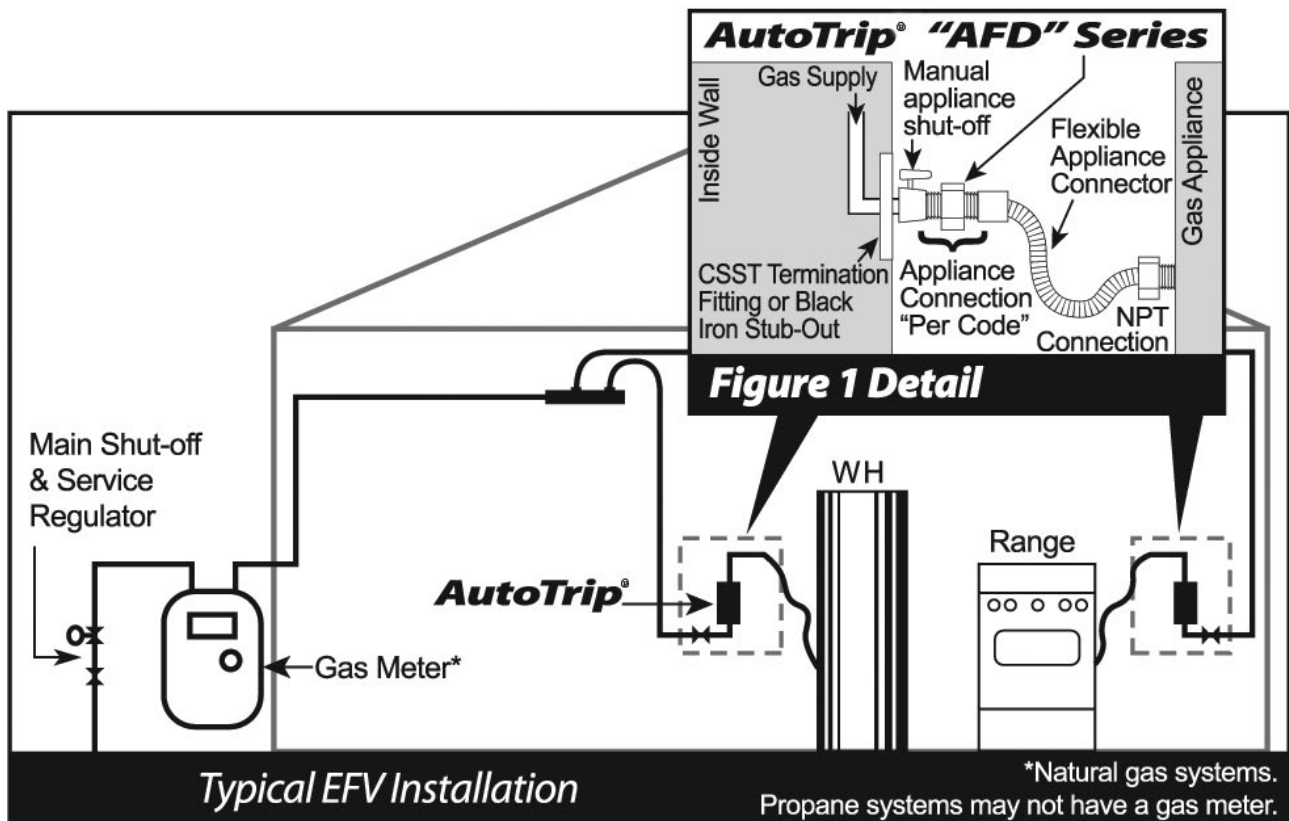

FIGURE: C-2

C1.3.1 - APPLICATION AND SELECTION OF AUTOTRIP® AFD SERIES EXCESS FLOW VALVES

1. Application. Determine the Type of EFV based on the application – for the AFD Series the application will be to install the EFV at the inlet to a flexible appliance connector (See Figure: C-2).
2. AFD Series EFV Model Selection. From TABLE: C.2, select the appropriate **AutoTrip®** AFD EFV based on:
 - A. The BTU/hr load capacity of the appliance it serves. (**NOTICE: AutoTrip®** Appliance Connector EFVs will serve only the appliance for which the flexible appliance connector is installed to). The TOTAL BTU/hr load capacity of the appliance should be equal to or less than the Maximum Load Capacity (BTU/hr) value of the **AutoTrip®** AFD EFV in TABLE: C.2.

B. Inlet side NPT and Outlet side SAE Flare connections, Nominal ID of the appliance connector being used.

- 3 Gas Piping System Sizing with an **AutoTrip®** AFD Series excess flow valve(s).

AutoTrip® excess flow valves must be sized properly for the gas piping system in which they are installed. When installing **AutoTrip®** excess flow valves within a fuel gas piping system, the user must assure that:

- A. The **AutoTrip®** excess flow valve will close upon a complete breakage or rupture of the gas appliance connector piping downstream of the EFV. It is recommended that the installer conduct tests on the gas piping system to ensure the EFV(s) will function as intended. Note: Tests should be performed in accordance with all applicable local and national codes.

- B. The addition of the EFV will allow the appliance to which the EFV serves to operate properly without the undue loss of pressure. It is recommended that the installer run all appliances with the EFV(s) installed to assure proper operation.

Based on the upstream gas piping system sizing and downstream appliance connector sizing, the user must assure that the addition of the AFD Series EFV will not reduce the inlet pressure to the appliance below the minimum required for proper operation.

NOTICE: AFD Series EFVs will add a Nominal 0.5 "wc pressure drop when operating at the Maximum Load Capacity (BTU/hr) of the EFV.

C1.3.2 INSTALLATION INSTRUCTIONS

- A. Installation of **AutoTrip**[®] Appliance Connector excess flow valves to the Flare connection of a Flexible Appliance Connector.

AutoTrip[®] Appliance Connector excess flow valves should be connected to the SAE Flare connection on the inlet side of an approved flexible appliance connector.

AutoTrip[®] Appliance Connector excess flow valves are designed for multipoise installation so they may be installed in the vertical, horizontal, or any angle from the horizontal, positions. **NOTICE:** Appliance Connector **AutoTrip**[®] excess flow valves are designed to protect against a complete breakage or pull-out of the flexible appliance connector only. This device will not protect gas piping upstream of the device.

B. Step-by-Step Installation Instructions

1. Prior to installing the **AutoTrip**[®] excess flow valve (EFV), turn gas supply off upstream of the EFV using appropriate shut-off valve. If the appliance shut-off valve is installed upstream of the appliance connector, this valve may be used as the shut-off.

TABLE: C.2

AutoTrip[®] "AFD" Series Appliance Connector Inlet Excess Flow Valves Application Data

EFV Type - Application	OmegaFlex AutoTrip P/N	Fits Nominal Appliance Connector ID Size	Mounting Position	Inlet Thread Connection(s)	Outlet Thread Connection(s)	Maximum Load Capacity (BTU/hr)	Nominal Closure Flow Rate (SCFH)
Appliance connector	FGP-AFD-80	1/4"	Multipoise	1/2" M-NPT & 3/8" F-NPT	3/8" SAE Flare	80,000	110
Appliance connector	FGP-AFD-100A	3/8"	Multipoise	1/2" M-NPT & 3/8" F-NPT	1/2" SAE Flare	100,000	175
Appliance connector	FGP-AFD-130A	1/2"	Multipoise	1/2" M-NPT & 3/8" F-NPT	5/8" SAE Flare	130,000	200
Appliance connector	FGP-AFD-130B	1/2"	Multipoise	3/4" M-NPT & 1/2" F-NPT	5/8" SAE Flare	130,000	200

Notes:

- 1) Flow Rates given for 0.60 Specific Gravity Natural Gas with an Avg. Heating Value of 1000 BTU / cubic foot.
- 2) To convert Maximum Load Capacity value to BTU/hr Propane (1.52 Specific Gravity, 2520 BTU / cubic foot), multiply Natural Gas Value by 1.583.
- 3) To convert SCFH Nominal Closure Flow Rate to SCFH Propane, multiply Natural gas Value above by 0.628
- 4) Abbreviations: "w.c. = inches water column.
SCFH = Standard Cubic Feet per Hour.

2. Install **AutoTrip**[®] EFV at the inlet to the flexible appliance connector using appropriate pipe fittings and tools. When using a thread sealant on pipe threads, do not allow the sealant, Teflon tape or any debris to enter the valve. Foreign matter can lodge in the valve and prevent proper operation.
3. After **AutoTrip**[®] EFV is installed, insure all connections in the gas piping system are gas tight.
4. Re-open upstream shut-off valve SLOWLY to re-pressurize the system. **NOTICE:** If upstream shut-off valve is opened too quickly and an excess flow condition is created due to a pressure surge the **AutoTrip**[®] EFV may trip (close). If this occurs, reset the valve using the Resetting an **AutoTrip**[®] EFV instructions below.
- 5 **Resetting an AutoTrip**[®] EFV that has “tripped” (closed). Repair all damaged piping as required. Reset the **AutoTrip**[®] EFV by closing and sealing off all downstream connections. Once the pressure in the downstream piping is equalized, valve will reset. This is evident by a “soft click” that can be heard from the **AutoTrip**[®] EFV. Typical time to reset is 15-30 seconds or of greater duration for larger diameter or longer length appliance connectors.

NOTICE: If there are any open connections (assure all appliance valves are shut) or leaks downstream of the **AutoTrip**[®] EFV, valve will not reset!

NOTICE: Resetting **AutoTrip**[®] Appliance Connector EFVs with appliance shut-off valve installed UPSTREAM of the EFV – These valves may be reset by closing and SLOWLY re-opening the upstream appliance shut-off valve without “tripping” the EFV.

⚠CAUTION: Installer must assure at all times that any gas that may have escaped from the gas piping system as a result of a pipe break, valve testing, leakage, etc. is completely dissipated prior to opening appliance shut-offs and firing of appliances. Assure that there is no electrical or motorized equipment in use during this process.

SECTION - C1.4 GASBREAKER[®] EXCESS FLOW VALVES

GasBreaker[®] excess flow valves (EFV) protect against residential and commercial gas line breaks. GasBreakers work in conjunction with **CounterStrike**[®], other brands of CSST or rigid gas piping at the gas meter, second stage regulator, the appliance branch line or manifold connection. GasBreaker EFVs are available in several different sizes and load capacity ratings.

1. The GasBreaker EFV can be installed downstream of the gas company meter and bypass tee outlet using standard pipe fittings and procedures. GasBreaker EFVs must be installed within 5 degrees of the vertical position with the flow arrow pointing upward in the direction of flow.
2. Use Table: C.4 for GasBreaker EFV capacity information and to determine the equivalent **AutoTrip**[®] LFD excess flow valve. For sizing of the **TracPipe**[®] **CounterStrike**[®] CSST system with GasBreaker EFV's utilize the equivalent **AutoTrip**[®] capacity chart data.

TABLE N-1AT TRACPIPE® AUTOTRIP® - (Low Pressure System)
Determine TracPipe CounterStrike CSST size based upon the AutoTrip “LFD” Series EFV Chosen and Length of CSST Run
Standard Low Pressure 0.5 psi or less (7 in w.c.)—Piping Pressure Drop 0.5 in w.c.

Distance Range – Length in Feet

AutoTrip P/N	Max. Capacity BTU	0-10 Feet	<15	<20	<25	<40	<50	<60	<90	<100	<150	<200	<250	<300
Appliance Branch Line Series														
FGP-LFD-70	70,000	1/2"	3/4"	3/4"	3/4"	3/4"	3/4"	3/4"	3/4"	1"	1"	1"	1"	1-1/4"
FGP-LFD-125	125,000	3/4"	3/4"	3/4"	3/4"	1"	1"	1"	1"	1-1/4"	1-1/4"	1-1/2"	1-1/2"	1-1/2"
Meter / Line Series														
FGP-LFD-275A or -275B	275,000	1"	1-1/4"	1-1/4"	1-1/4"	1-1/4"	1-1/2"	1-1/2"	1-1/2"	1-1/2"	1-1/2"	1-1/2"	2"	2"
FGP-LFD-375	375,000	1"	1-1/4"	1-1/4"	1-1/2"	1-1/2"	1-1/2"	1-1/2"	1-1/2"	1-1/2"	2"	2"	2"	2"
FGP-LFD-500	500,000	1-1/4"	1-1/2"	1-1/2"	1-1/2"	1-1/2"	1-1/2"	1-1/2"	2"	2"	2"	2"	2"	2"

NOTE: If you are installing a brand of CSST other than TracPipe CounterStrike, size each run to supply the Max Capacity of the AutoTrip device instead of the capacity of appliances on that run.

TABLE N-3AT TRACPIPE® AUTOTRIP® - (Dual Pressure System-8 in w.c. -Regulator outlet @ manifold)
Determine TracPipe CounterStrike CSST size based upon the AutoTrip “LFD” Series EFV Chosen and Length of CSST Run
Regulator Outlet for 2-psi system (8 in w.c. with a Piping Pressure Drop of 3 in w.c.)

Distance Range – Length in Feet

GasBreaker P/N	Max. Capacity BTU	0-10 Feet	<15	<20	<25	<40	<50	<60	<80	<90	<100	<150	<200	<250	<300
Appliance Branch Line Series															
FGP-LFD-70	70,000	3/8"	3/8"	1/2"	1/2"	1/2"	1/2"	1/2"	1/2"	1/2"	1/2"	3/4"	3/4"	3/4"	3/4"
FGP-LFD-125	125,000	1/2"	1/2"	1/2"	1/2"	3/4"	3/4"	3/4"	3/4"	3/4"	3/4"	1"	1"	1"	1"
Meter / Line Series															
FGP-LFD-275A or -275B	275,000	3/4"	3/4"	3/4"	1"	1"	1"	1"	1"	1"	1"	1-1/4"	1-1/4"	1-1/4"	1-1/2"
FGP-LFD-375	375,000	3/4"	3/4"	1"	1"	1"	1"	1-1/4"	1-1/4"	1-1/4"	1-1/4"	1-1/2"	1-1/2"	1-1/2"	1-1/2"
FGP-LFD-500	500,000	1"	1"	1"	1-1/4"	1-1/4"	1-1/4"	1-1/4"	1-1/4"	1-1/2"	1-1/2"	1-1/2"	1-1/2"	1-1/2"	1-1/2"

NOTE: If you are installing a brand of CSST other than TracPipe CounterStrike, size each run to supply the Max Capacity of the AutoTrip device instead of the capacity of appliances on that run.

TABLE N-5AT TRACPIPE® AUTOTRIP® - (2-PSI system)
Determine TracPipe CounterStrike CSST size based upon the AutoTrip “LFD” Series EFV Chosen and Length of CSST Run
Meter Outlet for 2-PSI system (Elevated Pressure) – Piping Pressure Drop 1-PSI

Distance Range – Length in Feet

GasBreaker P/N	Max. Capacity BTU	0-10 Feet	Distance Range – Length in Feet														
			<25	<30	<40	<50	<75	<80	<100	<150	<200	<250	<300	<400	<500		
Meter / Line Series																	
FGP-LFD-275A or -275B	275,000	3/8"	1/2"	1/2"	1/2"	1/2"	3/4"	3/4"	3/4"	3/4"	3/4"	3/4"	3/4"	3/4"	3/4"	1"	1"
FGP-LFD-375	375,000	1/2"	1/2"	3/4"	3/4"	3/4"	3/4"	3/4"	3/4"	3/4"	3/4"	1"	1"	1"	1"	1"	1"
FGP-LFD-500	500,000	1/2"	3/4"	3/4"	3/4"	3/4"	3/4"	3/4"	1"	1"	1"	1"	1"	1"	1"	1-1/4"	1-1/4"

NOTE: If you are installing a brand of CSST other than TracPipe CounterStrike, size each run to supply the Max Capacity of the AutoTrip device instead of the capacity of appliances on that run.

TABLE SP-1AT TRACPIPE® AUTOTRIP® - STEEL PIPE LOW PRESSURE
Determine TracPipe® CounterStrike® pipe size based upon the AutoTrip “LFD” Series EFV Chosen and Length of Run
Standard Low Pressure 0.5 PSI or less (7 in w.c.) – Piping Pressure Drop 0.5 in w.c.

Distance Range – Length in Feet

GasBreaker P/N	Max. Capacity BTU	0-10 Feet	Distance Range – Length in Feet														
			<20	<30	<40	<50	<60	<70	<90	<100	<125	<150	<200	<250	<300		
Appliance Branch Line Series																	
FGP-LFD-70	70,000	1/2" Pipe	1/2"	1/2"	1/2"	1/2"	3/4"	3/4"	3/4"	3/4"	3/4"	3/4"	3/4"	3/4"	3/4"	1"	1"
FGP-LFD-125	125,000	1/2" Pipe	3/4"	3/4"	3/4"	3/4"	3/4"	3/4"	3/4"	3/4"	1"	1"	1"	1"	1"	1-1/4"	1-1/4"
Meter / Line Series																	
FGP-LFD-275A or -275B	275,000	3/4" Pipe	1"	1"	1"	1"	1-1/4"	1-1/4"	1-1/4"	1-1/4"	1-1/4"	1-1/4"	1-1/4"	1-1/4"	1-1/4"	1-1/2"	1-1/2"
FGP-LFD-375	375,000	1" Pipe	1"	1"	1-1/4"	1-1/4"	1-1/4"	1-1/4"	1-1/4"	1-1/4"	1-1/4"	1-1/4"	1-1/4"	1-1/2"	1-1/2"	2"	2"
FGP-LFD-500	500,000	1" Pipe	1-1/4"	1-1/4"	1-1/4"	1-1/4"	1-1/4"	1-1/4"	1-1/4"	1-1/2"	1-1/2"	1-1/2"	1-1/2"	1-1/2"	2"	2"	2"

**TABLE 3.3
PROPANE – TracPipe® AutoTrip® - “LFD” Series Excess Flow Valves**

AutoTrip Flow Rates in 1.52 S.G. / 2520 BTU/cu.ft. PROPANE						
Device	Btu/hr			SCFH		
	Typ. Load	Max Load	Nom. Closing	Typ. Load	Max Load	Nom. Closing
Appliance Branch Line Series						
FGP-LFD-70	110,779	110,779	158,256	44	44	63
FGP-LFD-125	189,907	197,820	276,948	75	79	110
Meter / Line Series						
FGP-LFD-275A	197,820	435,204	561,809	79	173	223
FGP-LFD-275B	276,948	435,204	561,809	110	173	223
FGP-LFD-375	284,861	593,460	751,716	113	236	298
FGP-LFD-500	284,861	791,280	1,084,054	113	314	430

**TABLE P-1AT TRACPIPE® AUTOTRIP® - (Propane Low Pressure System 11 in w.c.)
Determine TracPipe CounterStrike CSST size based upon the AutoTrip “LFD” Series EFV Chosen and Length of CSST Run
Standard Propane Low Pressure (11 in w.c.) – Piping Pressure Drop 0.5 in w.c.**

Distance Range – Length in Feet

AutoTrip P/N	Max. Capacity BTU	0-10 Feet	<15	<20	<25	<40	<50	<60	<90	<100	<150	<200	<250	<300
Appliance Branch Line Series														
FGP-LFD-70	110,779	1/2"	1/2"	3/4"	3/4"	3/4"	3/4"	3/4"	1"	1"	1"	1"	1"	1-1/4"
FGP-LFD-125	197,820	3/4"	3/4"	3/4"	3/4"	1"	1"	1"	1"	1-1/4"	1-1/4"	1-1/2"	1-1/2"	1-1/2"
Meter / Line Series														
FGP-LFD-275A or -275B	435,204	1"	1"	1-1/4"	1-1/4"	1-1/4"	1-1/2"	1-1/2"	1-1/2"	1-1/2"	1-1/2"	1-1/2"	2"	2"
FGP-LFD-375	593,460	1"	1-1/4"	1-1/4"	1-1/4"	1-1/2"	1-1/2"	1-1/2"	1-1/2"	1-1/2"	2"	2"	2"	2"
FGP-LFD-500	791,280	1-1/4"	1-1/2"	1-1/2"	1-1/2"	1-1/2"	1-1/2"	1-1/2"	2"	2"	2"	2"	2"	2"

NOTE: If you are installing a brand of CSST other than TracPipe CounterStrike, size each run to supply the Max Capacity of the AutoTrip device instead of the capacity of appliances on that run.

**TABLE C.4
TracPipe® AUTOTRIP® - GasBreaker Equivalency Chart**

EFV Type Application	Maximum Load Capacity(Btu/hr)	Auto Trip P/N	Auto Trip Inlet and Outlet Thread Connection(s)	Equivalent GasBreaker P/N	GasBreaker Inlet and Outlet Thread Connection
Appliance Branch Line	70,000	FGP-LFD-70	3/4" M-NPT & 1/2" F-NPT	FGP-GB090-075	3/4" M-NPT
Appliance Branch Line	125,000	FGP-LFD-125	3/4" M-NPT & 1/2" F-NPT	FGP-GB150-075	3/4" M-NPT
Meter / Branch Line	275,000	FGP-LFD-275A	3/4" M-NPT & 1/2" F-NPT	FGP-GB300-075	3/4" M-NPT
Meter / Branch Line	275,000	FGP-LFD-275B	1" M-NPT & 3/4" F-NPT	FGP-GB300-100	1" M-NPT
Meter / Branch Line	375,000	FGP-LFD-375	1" M-NPT & 3/4" F-NPT	FGP-GB400-100	1" M-NPT
Meter / Branch Line	500,000	FGP-LFD-500	1-1/4" M-NPT & 1" F-NPT	FGP-GB600-100	1" M-NPT

NOTE: For additional information regarding the AutoTrip or GasBreaker excess flow valves, please contact *OmegaFlex* at 800-671-8622.

FIGURE C-3
Pressure Drop across TracPipe® AutoTrip® - "LFD" Series EFV at given Flow Rates

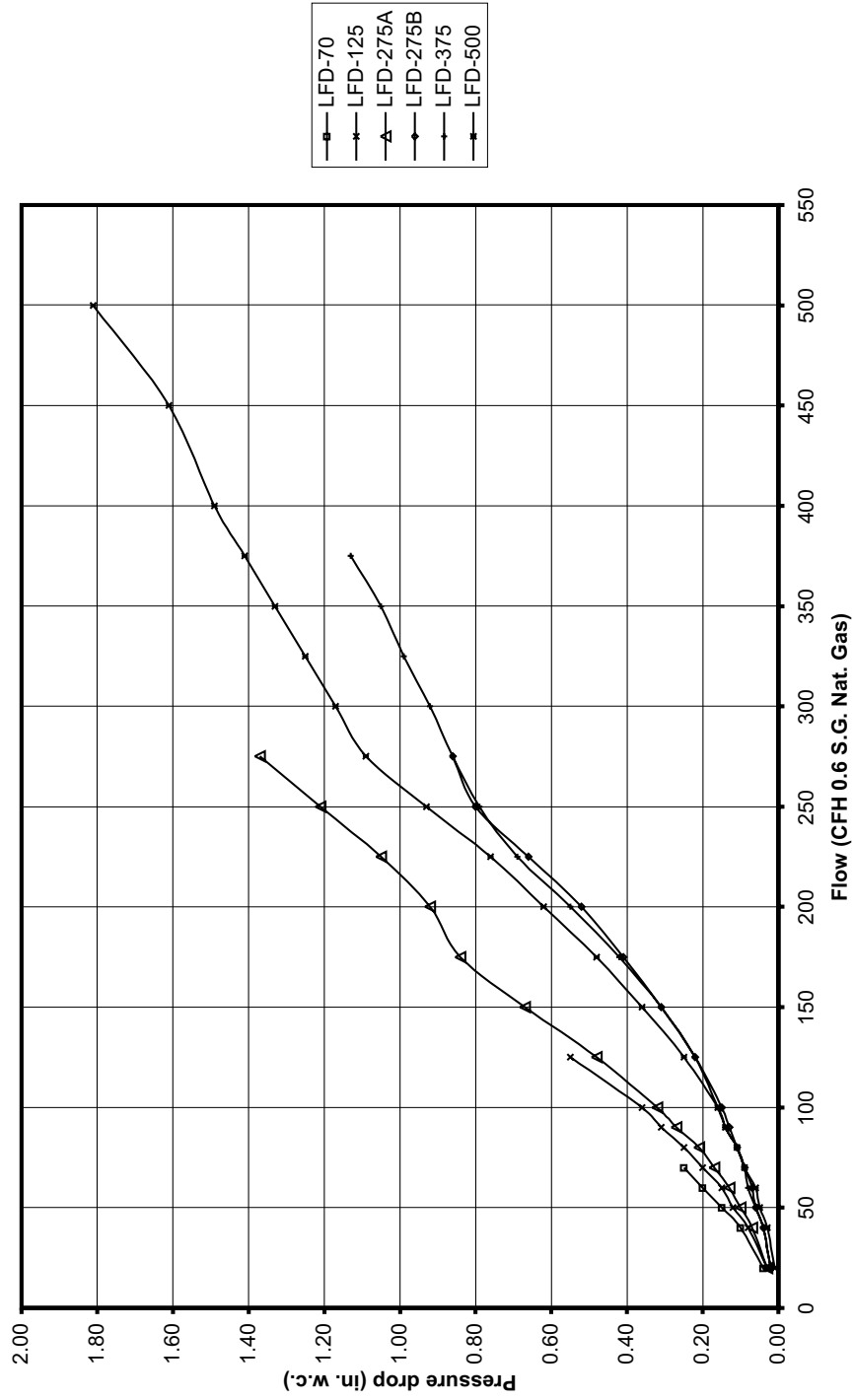

*For more information about
TracPipe® CounterStrike® visit:*
tracpipe.com

*For safety issues concerning
gas piping systems visit:*
csstfacts.org



TracPipe®  **CounterStrike®**
Flexible Gas Piping by OmegaFlex®

OmegaFlex®

451 Creamery Way,
Exton, PA 19341-2509
1-800-671-8622 Fax: 610-524-7282
www.omegaflex.com