

# STA-RITE<sup>®</sup> RESIDENTIAL WATER SYSTEMS



# PENTEK® XE-SERIES® SUBMERSIBLE MOTORS

## IT'S A MATTER OF TRUST.

You should never install a pump without a motor you can trust for performance and reliability.

Pentek XE Series 4" submersible motors consistently deliver outstanding performance through years of operation in the field... performance that has earned the trust of water well professionals.

*XE Series quality comes from the latest design, manufacturing and testing technology. We never compromise on quality, because at the end of the day, your trust is all that matters.*



---

# Table of Contents

<b>PRODUCT SELECTION GUIDE</b> .....	5-7
<b>4" SUBMERSIBLE PUMPS</b>	
HS Series 5 and 7 GPM TrimLine™ 4" Stainless Steel .....	8-13
HS Series 10, 15, 20, 30 and 50 GPM 4" Stainless Steel .....	14-25
JP Series 5 and 7 GPM TrimLine 4" Composite .....	26-31
JP Series 10, 15, 20 and 30 GPM 4" Composite .....	32-40
K Series 5, 7, 10 and 20 GPM 4" Composite .....	41-47
KS Series 10 and 20 GPM 4" Stainless Steel.....	48-52
ST.E.P. Plus D Series.....	53-57
70 GPM 4" Submersible Pump .....	58-61
75 and 90 GPM 4" High-Flo Submersible.....	62-65
4" x 6" Submersible Motor Adapter .....	66
<b>MOTORS AND CONTROLS</b>	
Pentek® XE Series™ 4" Submersible Motors.....	67-69
Submersible Motor Controls .....	70-74
Single-Phase Pump Protection .....	75-77
Pentek Intellidrive™ .....	78-80
Pentek Intellikit™ .....	81-82
Pentek Intellidrive™ XL .....	83-84
Pentek® XE-6 6" Submersible Motors and Controls .....	85-87
Hitachi® 6" Submersible Motors.....	88-89
<b>SHALLOW WELL JET PUMPS</b>	
CJ Self-Priming .....	90-92
HN Self-Priming Cast Iron.....	93-95
SN Self-Priming Cast Iron .....	96-98
FN Self-Priming Cast Iron .....	99-101
PN Self-Priming Corrosion-Resistant.....	102-104
FH Self-Priming Cast Iron .....	105-107
Jet Tank Packages .....	108-110
<b>CONVERTIBLE DEEP WELL JET PUMPS</b>	
HL Self-Priming Cast Iron .....	111-114
SL Self-Priming Cast Iron.....	115-118
FL Self-Priming Cast Iron.....	119-121
PL Corrosion-Resistant .....	122-124
HMS Vertical Multi-Stage .....	125-128
DMC Series Horizontal Multi-Stage .....	129-130
MS Vertical Multi-Stage.....	131-133
SSJ Vertical Single-Stage .....	134-136

(Continued on next page)

---

# Table of Contents

## **BOOSTER PUMPS**

Intelliboost® R Series Multi-Stage VFD Booster Pump .....	137-138
HP/HPS High-Pressure Booster .....	139-143

<b>JET PACKAGES AND ACCESSORIES</b> .....	144-147
---	---------

## **TANKS**

Pro-Source™ Composite Fibrewound Pressure .....	148-150
Pro-Source Composite Fibrewound Contact and Sideport Contact .....	151-152
Pro-Source Plus Steel Pressurized .....	153-155
Pro-Source Steel Pressurized .....	156-159
Pro-Source Epoxy Lined .....	160-161

## **CENTRIFUGAL AND UTILITY PUMPS**

Pro-Storm™ DSS Series Self-Priming Multi-Stage .....	162-163
DS2 Series .....	164-166
DS3 Pro-Storm .....	167-169
PD Self-Priming Corrosion-Resistant .....	170-171
D Self-Priming Cast Iron .....	172-177
CC Straight Centrifugal Cast Iron .....	178-180
DPC Self-Priming Cast Iron .....	181-182
J/JB General Purpose Cast Iron .....	183-186
Pro-Source Pumper .....	187-188
EDD/EEDD Engine-Driven Self-Priming .....	189-190

## **GENERAL INFORMATION**

Water Systems Product Nomenclature .....	191-192
Sizing Home Water Systems .....	193
Pipe Friction Loss Charts .....	194-195
Cable Selection 4" Submersible Motors .....	196-197

---

### **IMPORTANT NOTES**

Specifications and/or materials are subject to change without notice.  
Dimensions are for estimating purposes only.  
Products are tested and rated in accordance with  
Water Systems Council Standards.

Pentair trademarks and logos are owned by Pentair plc or its affiliates. All other  
third party registered and unregistered trademarks and logos are the property  
of their respective owners.

# Product Selection Guide



<b>PENTEK® MOTORS AND CONTROLS</b>					
<b>PRODUCT TYPE</b>	<b>4" SUBMERSIBLE MOTORS</b>	<b>SUBMERSIBLE MOTOR CONTROLS</b>	<b>6" SUBMERSIBLE MOTORS</b>	<b>CONSTANT PRESSURE CONTROLLER</b>	<b>SINGLE-PHASE MOTOR PROTECTORS</b>
<b>APPLICATION</b>	Water systems for residential, industrial, commercial, multiple housing and farm clean water use	Water systems for residential, industrial, commercial, multiple housing and farm clean water use	Water systems for residential, industrial, commercial, multiple housing and farm clean water use	Residential, commercial and irrigation constant pressure systems	Water systems for residential, industrial, commercial, multiple housing and farm clean water use
<b>DESCRIPTION</b>	Single- and three-phase 4" submersible high thrust motor	Single-phase motor controls for submersible applications	Single- and three-phase 6" submersible motor	Constant pressure controller for below and above ground applications	Single-phase motor protectors for submersible applications
<b>MATERIALS</b>	Stainless steel construction	NEMA 3R Enclosure	Stainless steel and epoxy-coated cast iron	NEMA 1, NEMA 3R, and NEMA 4X Enclosures Available	NEMA 3R Enclosure
<b>PERFORMANCE</b>					
Capacity	N/A	N/A	N/A	N/A	N/A
Head	N/A	N/A	N/A	N/A	N/A
<b>SUCTION/DISCHARGE</b>	N/A	N/A	N/A	N/A	N/A
<b>HORSEPOWER</b>	1/2 to 10 HP	1/2 to 15 HP	5 to 50 HP	1/2 to 150 HP	1/3 to 15 HP
<b>SERIES</b>	XE	SMC	XE-6	PID, XL	SPP

# Product Selection Guide

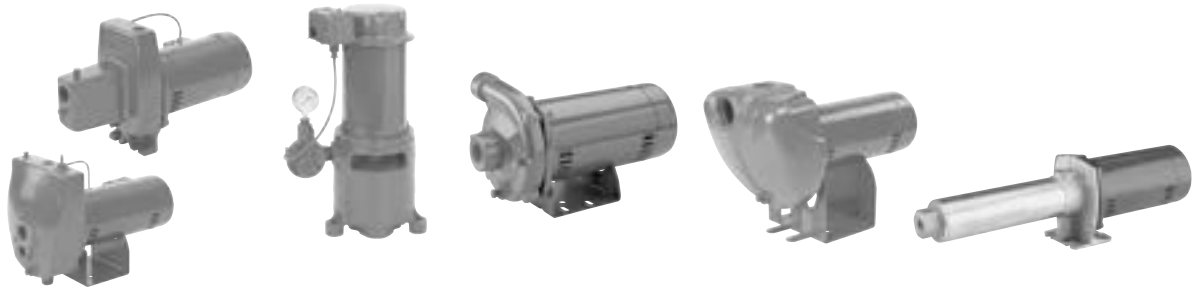

PRODUCT TYPE	SELF-PRIMING SHALLOW WELL AND CONVERTIBLE JET	VERTICAL SINGLE & MULTI-STAGE AND SELF-PRIMING HORIZONTAL MULTI-STAGE DEEP WELL JET	SMALL, STRAIGHT CENTRIFUGAL	SELF-PRIMING CENTRIFUGAL	HIGH PRESSURE BOOSTER PUMPS
APPLICATION	Residential and general water supply systems booster, and light irrigation	General water supply, booster and light irrigation for 2", 3" and 4" or larger water wells	General purpose, process, booster and liquid transfer	Lawn sprinkling, light irrigation, general dewatering and sump drainage, liquid transfer	General purpose booster, warm and cold water wash down, cleaning
DESCRIPTION	Threaded connections Motor-drive Mechanical seal Back pull-out design Convertible to deep well use	Threaded connections Motor-drive Mechanical seals	Threaded connections Motor-drive, ODP and TEFC Mechanical seals – standard and high temperature Back pull-out design 4-position discharge	Fast priming Threaded connections Motor- and engine-drive Portable or permanent installation Mechanical seals Back pull-out design	Threaded connections Motor-drive Mechanical seals ODP and TEFC motors
MATERIALS	Cast iron or fiberglass reinforced thermoplastic with thermoplastic impellers	Cast iron with thermoplastic impellers	Cast iron with bronze (high temperature) or thermoplastic impellers	Cast iron or fiberglass reinforced thermoplastic with bronze, cast iron or thermoplastic impellers	Signature 2000® – Stainless steel or cast iron construction with thermoplastic impellers/diffusers
<b>PERFORMANCE</b>					
Capacity	To 45 GPM	To 55 GPM	To 260 GPM	To 240 GPM	To 40 GPM
Head	To 160 TDH/ft.	To 325 TDH/ft.	To 140 TDH/ft.	To 160 TDH/ft.	To 690 TDH/ft.
SUCTION/DISCHARGE	1" to 1-1/4" 3/4" to 1"	1-1/4" suction, 1" drive 1"	1-1/4" to 2-1/2" 1" to 2"	1" to 3" 1" to 2-1/2"	3/4" to 1-1/4" 1" to 1-1/2"
HORSEPOWER	1/3 to 1-1/2 HP	1/2 to 2 HP	1/3 to 5 HP	1/2 to 5 HP	1/2 to 3 HP
SERIES	SN, HN, FN, PN, SL, HL, FL, PL	SSJ, MS, HMS	J/JB, CC	D, DS3, EDD, DPC, PD	HP, HPS

# Product Selection Guide



6" STAINLESS STEEL SUBMERSIBLE TURBINE	4" SUBMERSIBLE	WATER SYSTEMS TANKS		
		PRO-SOURCE® COMPOSITE PRESSURIZED FIBREWOUND	PRO-SOURCE PRO-SOURCE PLUS PRESSURIZED STEEL	PRO-SOURCE COMPOSITE CONTACT & SIDEPORT CONTACT "AIR OVER WATER" STEEL
General water supply, irrigation, booster, sump, circulation, dewatering	General water supply, booster, sump, circulation, and irrigation	General water storage and transfer	General water storage and transfer	General water storage and transfer
Crimped and threaded connections Completely submerged sealed motor coupled to pump	Threaded connections Completely submerged sealed motor 2 and 3 wire	Pre-pressurized composite well tank CSA Classified to ANSI/NSF 61 Field serviceable	Pre-pressurized steel well tank CSA Classified to ANSI/NSF 61	Air over water standard tank
All stainless steel construction	Signature 2000® – Stainless steel and composite construction with thermoplastic impellers/diffusers 70 GPM Series – Cast iron bowls with thermoplastic impellers 75 GPM and 90 GPM High-Flo Series	Pressure vessel: polyethylene Exterior: continuous, overlapping fiberglass strands, sealed with high-grade epoxy resin, then oven-cured	Pressure vessel: steel Exterior: baked-on powder polyester paint Water separator: PVC	Pressure vessel: steel Exterior: baked-on powder polyester paint Interior: baked-on epoxy paint
To 365 GPM To 1400 TDH/ft.	To 125 GPM To 1900 TDH/ft.	Physical Capacity: 14 - 119 gallons Drawdown: 5.3 - 43.8 gallons Maximum operating pressure: 125 PSI	Physical Capacity: 2 - 119 gallons Drawdown: 0.7 - 41.3 gallons Maximum operating pressure: 125 PSI	Physical Capacity: 30 - 264 gallons Drawdown: 7 - 50 gallons Maximum operating pressure: 100 PSI
3" to 4"	1-1/4" to 2"	1" to 1-1/4" NPT	3/4" to 1-1/4" NPT	1-1/4" NPT
1 to 60 HP	1/2 to 10 HP	N/A	N/A	N/A
Berkeley	Signature 2000 Series, 70 GPM Series and 90 GPM Series	Pro-Source Composite	Pro-Source Plus	Pro-Source Composite

# HS Series Signature 2000®

Stainless steel, 5 and 7 GPM TrimLine™



POWERED BY  
**PENTEK®**



**Precision-engineered, high-quality, rugged Signature 2000® Stainless Steel Series Pumps deliver efficient, dependable performance even in rough, aggressive water.**

**The TrimLine™ 5 and 7 GPM Series Pumps are 3-3/4" maximum O.D. Heads to 1,150 feet and capacities to 10.5 GPM. Built to deliver long-term, trouble-free service. Floating impeller design resists sand and reduces sand locking. These pumps feature the proven SignaSeal™ staging system.**

## APPLICATIONS

**Water systems...**for residential, industrial, commercial, multiple housing and farm use.

## SPECIFICATIONS

**Shell:** Stainless steel

**Discharge:** Stainless steel

**Discharge Bearing:** Nylatron®

**Intermediate Bearing:** (On larger units) polycarbonate, nitrile rubber and stainless steel

**Impellers:** Acetal

**Diffusers:** Polycarbonate

**Suction Caps:** Polycarbonate with stainless steel insert

**Thrust Pads:** Proprietary spec.

**Shaft and Coupling:** Stainless steel

**Intake:** Stainless steel

**Intake Screen:** Stainless steel

**Cable Guard:** Stainless steel

**Agency Listings:** CSA

**Check Valve:** Acetal

## FEATURES

**Proven Staging System:** Our proven SignaSeal staging system incorporates a harder-than-sand ceramic wear surface that when incorporated with our floating impeller design, greatly reduces problems with abrasives, sand lock-up and running dry.

**Discharge:** Corrosion-resistant 300 grade stainless steel for durability in aggressive water. Large octagon wrench area for ease of installation.

**Discharge Bearing:** Exclusive self-lubricating Nylatron bearing resists wear from sand.

**Intake:** Corrosion-resistant 300 grade stainless steel for durability in aggressive water.

**Shaft:** Positive drive from 7/16" hexagonal heavy-duty 300 grade stainless steel.

**Coupling:** Stainless steel press fit to pump shaft. Couples to all standard NEMA motors.

**Shell:** Heavy-walled corrosion-resistant 300 grade stainless steel. Threaded for easy servicing.

**Hardware:** All screws, washers and nuts are corrosion-resistant 300 grade stainless steel.

**Check Valve:** Durable internal spring-loaded check valve.

**Cable Guard:** Corrosion-resistant stainless steel guard protects motor leads. Tapered ends prevent pump from catching on well.

**Intake Screen:** Corrosion-proof stainless steel.

**Pentek® XE Series™ Motor:** 2 and 3 wire NEMA standard all stainless construction water-filled motors.

# HS Series Signature 2000®

Stainless steel, 5 and 7 GPM TrimLine™

## ORDERING INFORMATION

GPM	MOTOR TYPE	HP	STGS.	PH <sup>†</sup>	VOLT	ASSEMBLED PUMP			PUMP END			MOTOR		CONTROL BOX		
						CATALOG NUMBER	LENGTH IN.*	WEIGHT LBS.*	CATALOG NUMBER	LENGTH IN.*	WEIGHT LBS.*	CATALOG NUMBER	WEIGHT LBS.*	CATALOG NUMBER	WEIGHT LBS.*	
5	2 WIRE	1/2	14	1	115	S5P4HS05121	28	28	L5P4CHL	18	12	P42B0005A1	19			
		1/2	14	1	230	S5P4HS05221	28	28	L5P4CHL	18	12	P42B0005A2	19			
		3/4	19	1	230	S5P4HS07221	33	34	L5P4DHL	22	15	P42B0007A2	23			
		1	22	1	230	S5P4HS10221	37	39	L5P4EHL	26	17	P42B0010A2	25			
		1-1/2	30	1	230	S5P4HS15221	47	51	L5P4FHL	32	21	P42B0015A2	29			
	3 WIRE	1/2	13	1	115	S5P4HS05131	27-1/2	28	L5P4CHL	18	12	P43B0005A1	19	SMC-IR0511	4	
		1/2	14	1	230	S5P4HS05231	28	28	L5P4CHL	18	12	P43B0005A2	18	SMC-CR0521	4	
		3/4	19	1	230	S5P4HS07231	33	34	L5P4DHL	22	15	P43B0007A2	21	SMC-CR0721	4	
		1	22	1	230	S5P4HS10231	38	39	L5P4EHL	26	17	P43B0010A2	23	SMC-CR1021	4	
		1-1/2	30	1	230	S5P4HS15231	46	48	L5P4FHL	32	21	P43B0015A2	27	SMC-CR1521	7	
		1-1/2	30	3	230				L5P4FHL	32	21	P43B0015A3	23			
		1-1/2	30	3	460				L5P4FHL	32	21	P43B0015A4	23			
		2	38	1	230				L5P4GHL	37-3/4	25	P43B0020A2	31	SMC-CR2021	7	
		2	38	3	230				L5P4GHL	37-3/4	25	P43B0020A3	23			
	2	38	3	460				L5P4GHL	37-3/4	25	P43B0020A4	23				
	7	2 WIRE	1/2	11	1	115	S7P4HS05121	26	27	L7P4CHL	16	11	P42B0005A1	19		
			1/2	11	1	230	S7P4HS05221	26	27	L7P4CHL	16	11	P42B0005A2	19		
			3/4	15	1	230	S7P4HS07221	30	32	L7P4DHL	19	13	P42B0007A2	23		
1			18	1	230	S7P4HS10221	34	37	L7P4EHL	22	15	P42B0010A2	25			
1-1/2			22	1	230	S7P4HS15221	43	47	L7P4FHL	28	17	P42B0015A2	29			
3 WIRE		1/2	10	1	115	S7P4HS05131	25-1/2	27	L7P4CHL	16	11	P43B0005A1	19	SMC-IR0511	4	
		1/2	11	1	230	S7P4HS05231	26	27	L7P4CHL	16	11	P43B0005A2	18	SMC-CR0521	4	
		3/4	15	1	230	S7P4HS07231	30	32	L7P4DHL	19	13	P43B0007A2	21	SMC-CR0721	4	
		1	18	1	230	S7P4HS10231	34	37	L7P4EHL	22	15	P43B0010A2	23	SMC-CR1021	4	
		1-1/2	22	1	230	S7P4HS15231	42	44	L7P4FHL	28	17	P43B0015A2	27	SMC-CR1521	7	
		1-1/2	22	3	230				L7P4FHL	27-1/4	17	P43B0015A3	23			
		1-1/2	22	3	460				L7P4FHL	27-1/4	17	P43B0015A4	23			
		2	28	1	230				L7P4GHL	32-1/2	20	P43B0020A2	31	SMC-CR2021	7	
		2	28	3	230				L7P4GHL	32-1/2	20	P43B0020A3	27			
		2	28	3	460				L7P4GHL	32-1/2	20	P43B0020A4	27			
		3	36	1	230				L7P4HHL	39-1/2	24	P43B0030A2	37	SMC-CR3021	8	
		3	36	3	230				L7P4HHL	39-1/2	24	P43B0030A3	37			
		3	36	3	460				L7P4HHL	39-1/2	24	P43B0030A4	37			

†For all Pentek XE series three-phase motor options, see page 65.

\*Length and Weight are approximate.

TrimLine™ version maximum outside diameter is 3-3/4". Standard version maximum outside diameter is 3-7/8".

NOTE: Motor, Control Box or Magnetic Starter must be ordered separately, if ordering pump end only. Discharge NPT is 1-1/4".

# HS Series Signature 2000®

Stainless steel, 5 and 7 GPM TrimLine™

## OUTLINE DIMENSIONS

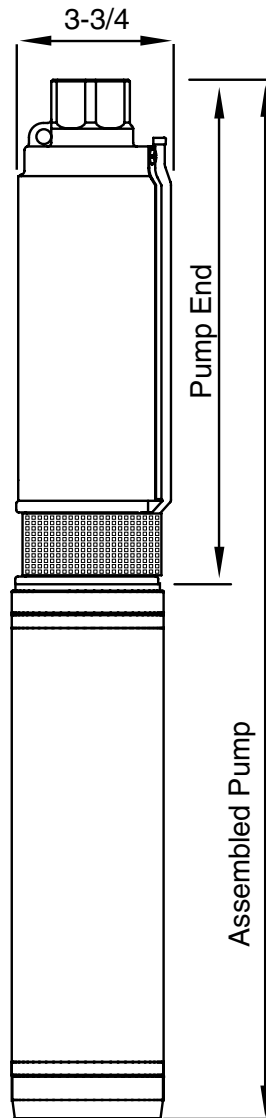

DISCHARGE	
5 GPM	1-1/4" NPT
7 GPM	1-1/4" NPT

For dimensions, refer to Ordering Information table.  
Dimensions (in inches) are for estimating purposes only.

# HS Series Signature 2000®

Stainless steel, 5 and 7 GPM TrimLine™

## PUMP PERFORMANCE: 5 GPM

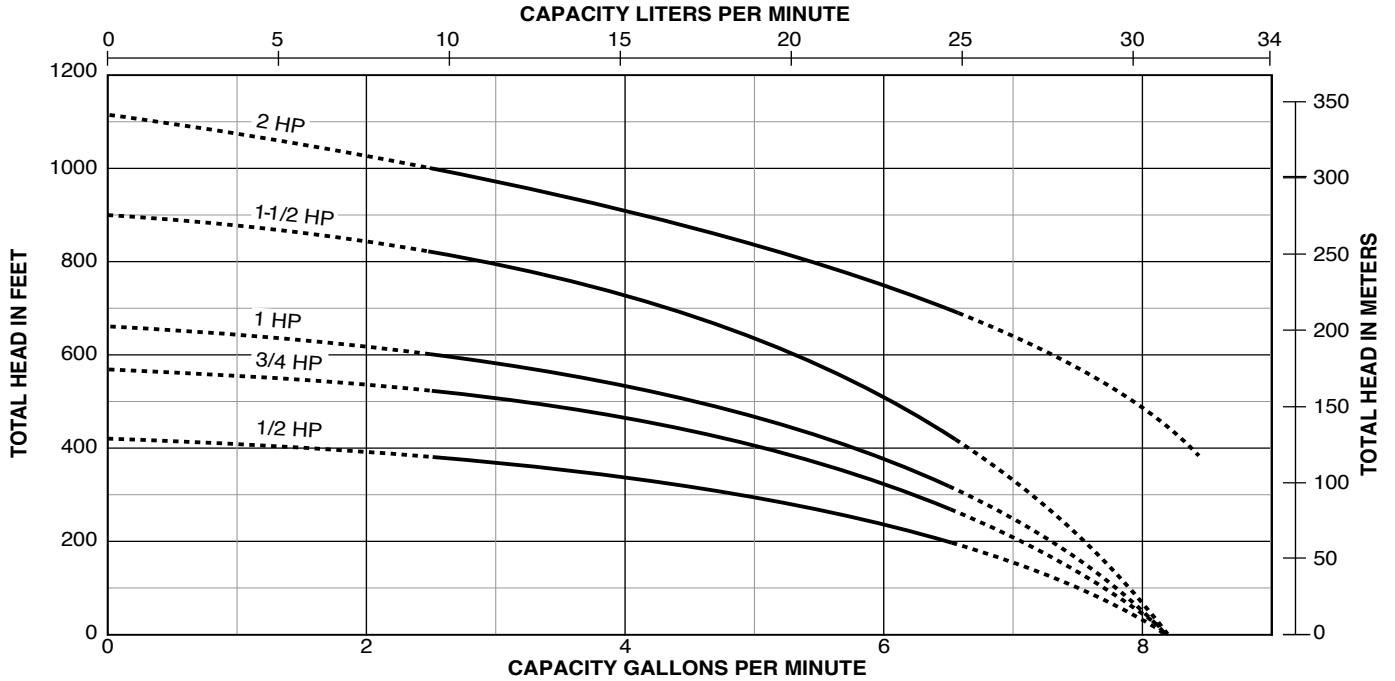

## PUMP PERFORMANCE: 7 GPM

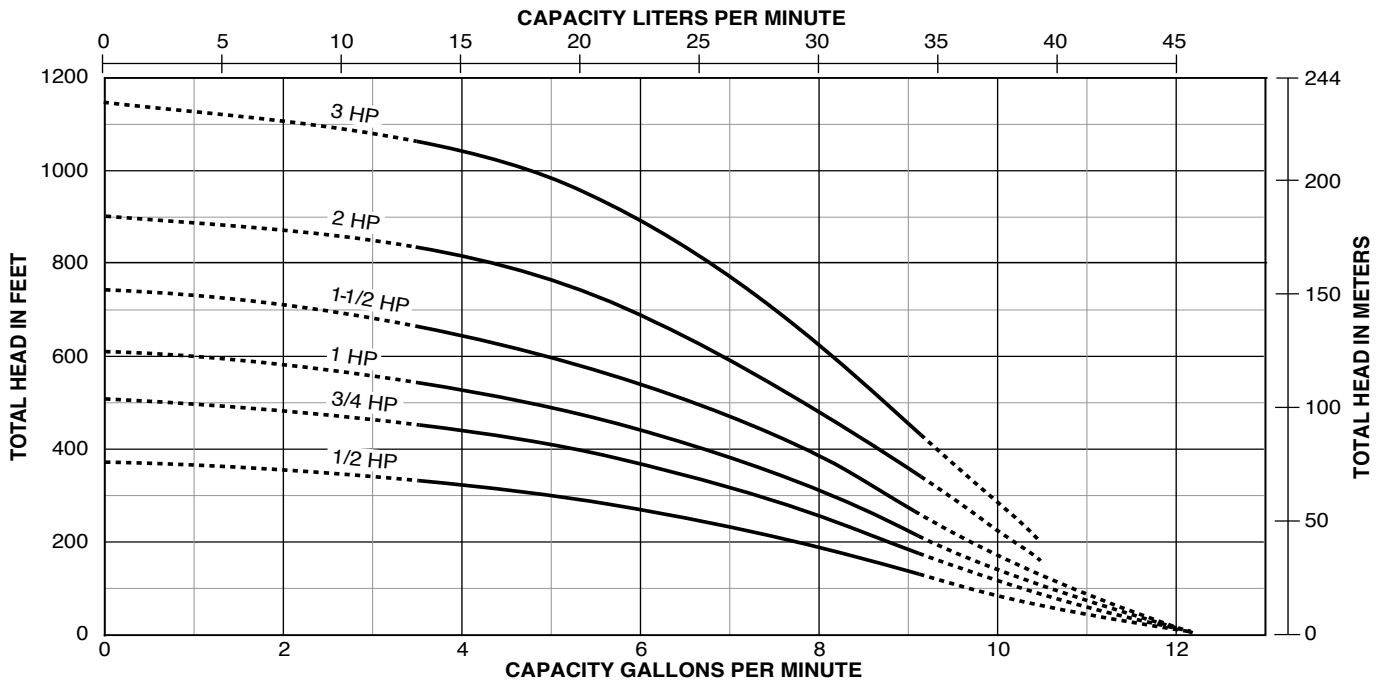

Tested and rated in accordance with Water Systems Council Standards.

NOTE: Pumps installed with a Pro-Source® tank require a 100 PSI relief valve. Pumps installed with a conventional tank require a 75 PSI relief valve. Relief valve must be capable of relieving entire flow of pump at relief pressure.





# HS Series Signature 2000®

Stainless Steel



POWERED BY  
**PENTEK®**



**Precision-engineered, high-quality, rugged Signature 2000® Stainless Steel Series Pumps deliver efficient, dependable performance even in rough, aggressive water. Heads to 1,950 feet and capacities to 65 GPM. Built to deliver long-term, trouble-free service. Floating impeller design resists sand and reduces sand locking. These pumps feature the proven SignaSeal™ staging system.**

## APPLICATIONS

**Water systems...**for residential, industrial, commercial, multiple housing and farm use.

## SPECIFICATIONS

**Shell:** Stainless steel

**Diameter:** 3-7/8"

**Discharge:** Stainless steel

**Discharge Bearing:** Nylatron®

**Intermediate Bearing:** (On larger units) polycarbonate, nitrile rubber and stainless steel

**Impellers:** Acetal

**Diffusers:** Polycarbonate

**Suction Caps:** Polycarbonate with stainless steel insert

**Thrust Pads:** Proprietary spec.

**Shaft and Coupling:** Stainless steel

**Intake:** Stainless steel

**Intake Screen:** Polypropylene

**Cable Guard:** Stainless steel

**Check Valve:** Acetal†

**Agency Listings:** CSA

## FEATURES

**Proven Staging System:** Our proven SignaSeal staging system incorporates a harder-than-sand ceramic wear surface that when incorporated with our floating impeller design, greatly reduces problems with abrasives, sand lock-up and running dry.

**Discharge:** Corrosion-resistant 300 grade stainless steel for durability in aggressive water. Large octagon wrench area for ease of installation.

**Discharge Bearing:** Self-lubricating Nylatron bearing resists wear from sand.

**Intake:** Corrosion-resistant 300 grade stainless steel for durability in aggressive water.

**Shaft:** Positive drive from 7/16" hexagonal heavy-duty 300 grade stainless steel.

**Coupling:** Stainless steel press fit to pump shaft. Couples to all standard NEMA motors.

**Shell:** Highest grade, heavy-walled corrosion-resistant stainless steel. Threaded for easy servicing.

**Hardware:** All screws, washers and nuts are corrosion-resistant 300 grade stainless steel.

**Check Valve:** Durable internal spring-loaded check valve.

**Cable Guard:** Corrosion-resistant stainless steel guard protects motor leads. Tapered ends prevent pump from catching on well.

**Intake Screen:** Corrosion-proof.

**Pentek® XE Series™ Motor:** 2 and 3 wire NEMA standard all stainless construction water-filled motors.

†Except where noted.

Pentair trademarks and logos are owned by Pentair plc or its affiliates. All other third party registered and unregistered trademarks and logos are the property of their respective owners.

# HS Series Signature 2000®

Stainless Steel

## ORDERING INFORMATION

GPM	MOTOR TYPE	HP	STGS.	PH†	VOLT	ASSEMBLED PUMP			PUMP END			MOTOR		CONTROL BOX	
						CATALOG NUMBER	LENGTH INCHES*	WEIGHT POUNDS*	CATALOG NUMBER	LENGTH INCHES*	WEIGHT POUNDS*	CATALOG NUMBER	WEIGHT POUNDS*	CATALOG NUMBER	WEIGHT POUNDS*
10**	2 WIRE	1/2	8	1	115	S10P4HS05121	23	28	L10P4CH	13	9	P42B0005A1	19		
		1/2	8	1	230	S10P4HS05221	23	28	L10P4CH	13	9	P42B0005A2	19		
		3/4	11	1	230	S10P4HS07221	26	31	L10P4DH	15	10	P42B0007A2	23		
		1	13	1	230	S10P4HS10221	29	35	L10P4EH	17	11	P42B0010A2	25		
		1-1/2	17	1	230	S10P4HS15221	35	42	L10P4FH	20	12	P42B0015A2	29		
	3 WIRE	1/2	7	1	115	S10P4HS05131	22-3/4	27-1/2	L10P4CH	12-3/4	9	P43B0005A1	19	SMC-IR0511	4
		1/2	8	1	230	S10P4HS05231	23	28	L10P4CH	13	9	P43B0005A2	19	SMC-CR0521	4
		3/4	11	1	230	S10P4HS07231	26	31	L10P4DH	15	10	P43B0007A2	21	SMC-CR0721	4
		1	13	1	230	S10P4HS10231	29	35	L10P4EH	17	11	P43B0010A2	23	SMC-CR1021	4
		1-1/2	17	1	230	S10P4HS15231	34	42	L10P4FH	20	12	P43B0015A2	27	SMC-CR1521	7
		1-1/2	17	3	230				L10P4FH	19-3/4	12-1/2	P43B0015A3	23		
		1-1/2	17	3	460				L10P4FH	19-3/4	12-1/2	P43B0015A4	23		
		2	22	1	230				L10P4GH	22	13-3/4	P43B0020A2	31	SMC-CR2021	7
		2	22	3	230				L10P4GH	22	13-3/4	P43B0020A3	23		
		2	22	3	460				L10P4GH	22	13-3/4	P43B0020A4	23		
		3	30	1	230				L10P4HH	22	16-3/4	P43B0030A2	40	SMC-CR3021	8
		3	30	3	230				L10P4HH	28	16-3/4	P43B0030A3	32		
		3	30	3	460				L10P4HH	28	16-3/4	P43B0030A4	32		
		5	50	1	230				L10P4JH	43-1/2	25-1/2	P43B0050A2	70	SMC-CR5021	12
		5	50	3	230				L10P4JH	43-1/2	25-1/2	P43B0050A3	55		
5	50	3	460				L10P4JH	43-1/2	25-1/2	P43B0050A4	55				
15**	2 WIRE	1/2	6	1	115	S15P4HS05121	23	27	L15P4CH	13	9	P42B0005A1	19		
		1/2	6	1	230	S15P4HS05221	23	27	L15P4CH	13	9	P42B0005A2	19		
		3/4	8	1	230	S15P4HS07221	26	31	L15P4DH	15	10	P42B0007A2	23		
		1	10	1	230	S15P4HS10221	30	35	L15P4EH	17	11	P42B0010A2	25		
		1-1/2	12	1	230	S15P4HS15221	36	43	L15P4FH	21	13	P42B0015A2	29		
	3 WIRE	1/2	5	1	115	S15P4HS05131	22-1/4	27	L15P4CH	12-1/4	9	P43B0005A1	19	SMC-IR0511	4
		1/2	6	1	230	S15P4HS05231	23	27	L15P4CH	13	9	P43B0005A2	19	SMC-CR0521	4
		3/4	8	1	230	S15P4HS07231	26	31	L15P4DH	15	10	P43B0007A2	23	SMC-CR0721	4
		1	10	1	230	S15P4HS10231	30	35	L15P4EH	17	11	P43B0010A2	25	SMC-CR1021	4
		1-1/2	12	1	230	S15P4HS15231	34	41	L15P4FH	21	13	P43B0015A2	29	SMC-CR1521	7
		1-1/2	12	3	230				L15P4FH	20-1/4	13	P43B0015A3	23		
		1-1/2	12	3	460				L15P4FH	20-1/4	13	P43B0015A4	23		
		2	15	1	230				L15P4GH	23-1/2	15	P43B0020A2	31	SMC-CR2021	7
		2	15	3	230				L15P4GH	23-1/2	15	P43B0020A3	23		
		2	15	3	460				L15P4GH	23-1/2	15	P43B0020A4	23		
		3	22	1	230				L15P4HH	31-1/4	18	P43B0030A2	40	SMC-CR3021	7
		3	22	3	230				L15P4HH	31-1/4	18	P43B0030A3	32		
		3	22	3	460				L15P4HH	31-1/4	18	P43B0030A4	32		

†For all Pentek XE series three-phase motor options, see page 65.

\*Length and Weight are approximate.

\*\*For 10 GPM, 15 GPM and 20 GPM discharge is 1-1/4" NPT.

\*\*\*For 30 GPM and 50 GPM discharge is 2" NPT.

NOTE: On 2 HP and larger – Pump, Motor, Control Box or Magnetic Starter must be ordered separately.

†Check Valve not included on 5 HP, 7-1/2 HP and 10 HP models. Check Valve not included on 50 GPM models.

TrimLine™ version maximum outside diameter is 3-3/4". Standard version maximum outside diameter on all models is 3-7/8".

# HS Series Signature 2000®

Stainless Steel

## ORDERING INFORMATION

GPM	MOTOR TYPE	HP	STGS.	PH†	VOLT	ASSEMBLED PUMP			PUMP END			MOTOR		CONTROL BOX	
						CATALOG NUMBER	LENGTH INCHES*	WEIGHT POUNDS*	CATALOG NUMBER	LENGTH INCHES*	WEIGHT POUNDS*	CATALOG NUMBER	WEIGHT POUNDS*	CATALOG NUMBER	WEIGHT POUNDS*
20**	2 WIRE	3/4	6	1	230	S20P4HS07221	24	30	L20P4DH	13	9	P42B0007A2	23		
		1	7	1	230	S20P4HS10221	28	34	L20P4EH	15	10	P42B0010A2	25		
		1-1/2	10	1	230	S20P4HS15221	32	39	L20P4FH	17	11	P42B0015A2	29		
	3 WIRE	3/4	6	1	230	S20P4HS07231	24	30	L20P4DH	13	9	P43B0007A2	23	SMC-CR0721	5
		1	7	1	230	S20P4HS10231	28	34	L20P4EH	15	10	P43B0010A2	25	SMC-CR1021	5
		1-1/2	10	1	230	S20P4HS15231	31	39	L20P4FH	17	11	P43B0015A2	29	SMC-CR1521	7
		1-1/2	9	3	230				L20P4FH	16-3/4	10-3/4	P43B0015A3	23		
		1-1/2	9	3	460				L20P4FH	16-3/4	10-3/4	P43B0015A4	23		
		2	12	1	230				L20P4GH	20-1/4	12-1/2	P43B0020A2	31	SMC-CR2021	7
		2	12	3	230				L20P4GH	20-1/4	12-1/2	P43B0020A3	32		
		2	12	3	460				L20P4GH	20-1/4	12-1/2	P43B0020A4	32		
		3	17	1	230				L20P4HH	25-3/4	15	P43B0030A2	40	SMC-CR3021	7
		3	17	3	230				L20P4HH	25-3/4	15	P43B0030A3	32		
		3	17	3	460				L20P4HH	25-3/4	15	P43B0030A4	32		
		5	28	1	230				L20P4JH	38	21	P43B0050A2	70	SMC-CR5021	8
		5	28	3	230				L20P4JH	38	21	P43B0050A3	55		
		5	28	3	460				L20P4JH	38	21	P43B0050A4	55		
		7-1/2	40	3	230				L20P4KH	53-3/4	30	P43B0075A3	70		
		7-1/2	40	3	460				L20P4KH	53-3/4	30	P43B0075A4	70		
		10	54	3	460				L20P4LH	71	41	P43B0100A4	78		
30***	2 WIRE	1	5	1	230	S30P4HS10221	26-1/2	35	L30P4EH	14	9-3/4	P42B0010A2	25		
		1-1/2	6	1	230	S30P4HS15221	30-1/2	39	L30P4FH	15-1/4	10-3/4	P42B0015A2	29		
	3 WIRE	1	5	1	230	S30P4HS10231	26-1/2	35	L30P4EH	14	10	P43B0010A2	25	SMC-CR1021	5
		1-1/2	6	1	230	S30P4HS15231	29	39	L30P4FH	15-1/4	11	P43B0015A2	29	SMC-CR-1521	7
		1-1/2	6	3	230				L30P4FH	15-1/4	11	P43B0015A3	23		
		1-1/2	6	3	460				L30P4FH	15-1/4	11	P43B0015A4	23		
		2	8	1	230				L30P4GH	18-1/4	12	P43B0020A2	31	SMC-CR2021	7
		2	8	3	230				L30P4GH	18-1/4	12	P43B0020A3	23		
		2	8	3	460				L30P4GH	18-1/4	12	P43B0020A4	23		
		3	12	1	230				L30P4HH	24	15	P43B0030A2	40	SMC-CR3021	7
		3	12	3	230				L30P4HH	24	15	P43B0030A3	32		
		3	12	3	460				L30P4HH	24	15	P43B0030A4	32		
		5	20	1	230				L30P4JH	35-3/4	20	P43B0050A2	70	SMC-CR5021	8
		5	20	3	230				L30P4JH	35-3/4	20	P43B0050A3	55		
		5	20	3	460				L30P4JH	35-3/4	20	P43B0050A4	55		
		7-1/2	28	3	230				L30P4KH	50	27	P43B0075A3	70		
		7-1/2	28	3	460				L30P4KH	50	27	P43B0075A4	70		
		10	38	3	460				L30P4LH	65-1/2	35	P43B0100A4	70		

†For all Pentek XE series three-phase motor options, see page 65.

\*Length and Weight are approximate.

\*\*For 10 GPM, 15 GPM and 20 GPM discharge is 1-1/4" NPT.

\*\*\*For 30 GPM and 50 GPM discharge is 2" NPT.

NOTE: On 2 HP and larger – Pump, Motor, Control Box or Magnetic Starter must be ordered separately.

†Check Valve not included on 5 HP, 7-1/2 HP and 10 HP models. Check Valve not included on 50 GPM models.

TrimLine™ version maximum outside diameter is 3-3/4". Standard version maximum outside diameter on all models is 3-7/8".

# HS Series Signature 2000®

Stainless Steel

## ORDERING INFORMATION

GPM	MOTOR TYPE	HP	STGS.	PH <sup>†</sup>	VOLT	PUMP END			MOTOR		CONTROL BOX	
						CATALOG NUMBER	LENGTH INCHES*	WEIGHT POUNDS*	CATALOG NUMBER	WEIGHT POUNDS*	CATALOG NUMBER	WEIGHT POUNDS*
50***	2 WIRE	1-1/2	4	1	230	L50P4FH	15-1/4	10	P42B0015A2	29		
		1-1/2	4	1	230	L50P4FH	15-1/4	10	P43B0015A2	27	SMC-CR1521	7
	3 WIRE	1-1/2	4	3	230	L50P4FH	15-1/4	10	P43B0015A3	23		
		1-1/2	4	3	460	L50P4FH	15-1/4	10	P43B0015A4	23		
		2	6	1	230	L50P4GH	19-1/4	12	P43B0020A2	31	SMC-CR2021	7
		2	6	3	230	L50P4GH	19-1/4	12	P43B0020A3	27		
		2	6	3	460	L50P4GH	19-1/4	12	P43B0020A4	27		
		3	8	1	230	L50P4HH	23-1/4	15	P43B0030A2	40	SMC-CR3021	7
		3	8	3	230	L50P4HH	23-1/4	15	P43B0030A3	32		
		3	8	3	460	L50P4HH	23-1/4	15	P43B0030A4	32		
		5	13	1	230	L50P4JH	33-1/2	20	P43B0050A2	70	SMC-CR5021	8
		5	13	3	230	L50P4JH	33-1/2	20	P43B0050A3	55		
		5	13	3	460	L50P4JH	33-1/2	20	P43B0050A4	55		
		7-1/2	20	3	230	L50P4KH	47-1/2	25	P43B0075A3	70		
		7-1/2	20	3	460	L50P4KH	47-1/2	25	P43B0075A4	70		
		10	25	3	460	L50P4LH	57-3/4	35	P43B0100A4	70		

†For all Pentek XE series three-phase motor options, see page 65.

\*Length and Weight are approximate.

\*\*For 10 GPM, 15 GPM and 20 GPM discharge is 1-1/4" NPT.

\*\*\*For 30 GPM and 50 GPM discharge is 2" NPT.

NOTE: Pump, Motor, Control Box or Magnetic Starter must be ordered separately.  
Check Valve not included on 50 GPM models.

# HS Series Signature 2000®

Stainless Steel

## OUTLINE DIMENSIONS: 10, 15 AND 20 GPM

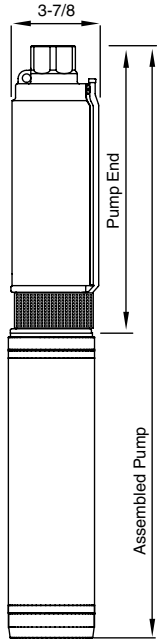

DISCHARGE	
10 GPM	1-1/4" NPT
15 GPM	1-1/4" NPT
20 GPM	1-1/4" NPT

For lengths, refer to Ordering Information tables.  
Dimensions (in inches) are for estimating purposes only.

## OUTLINE DIMENSIONS: 30 AND 50 GPM

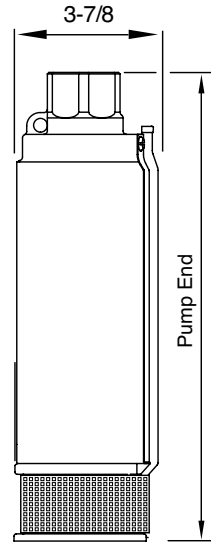

DISCHARGE	
30 GPM	2" NPT
50 GPM	2" NPT

Pump diameter is 3-7/8".  
For lengths, refer to Ordering Information tables.  
Dimensions (in inches) are for estimating purposes only.

## PUMP PERFORMANCE: 10 GPM

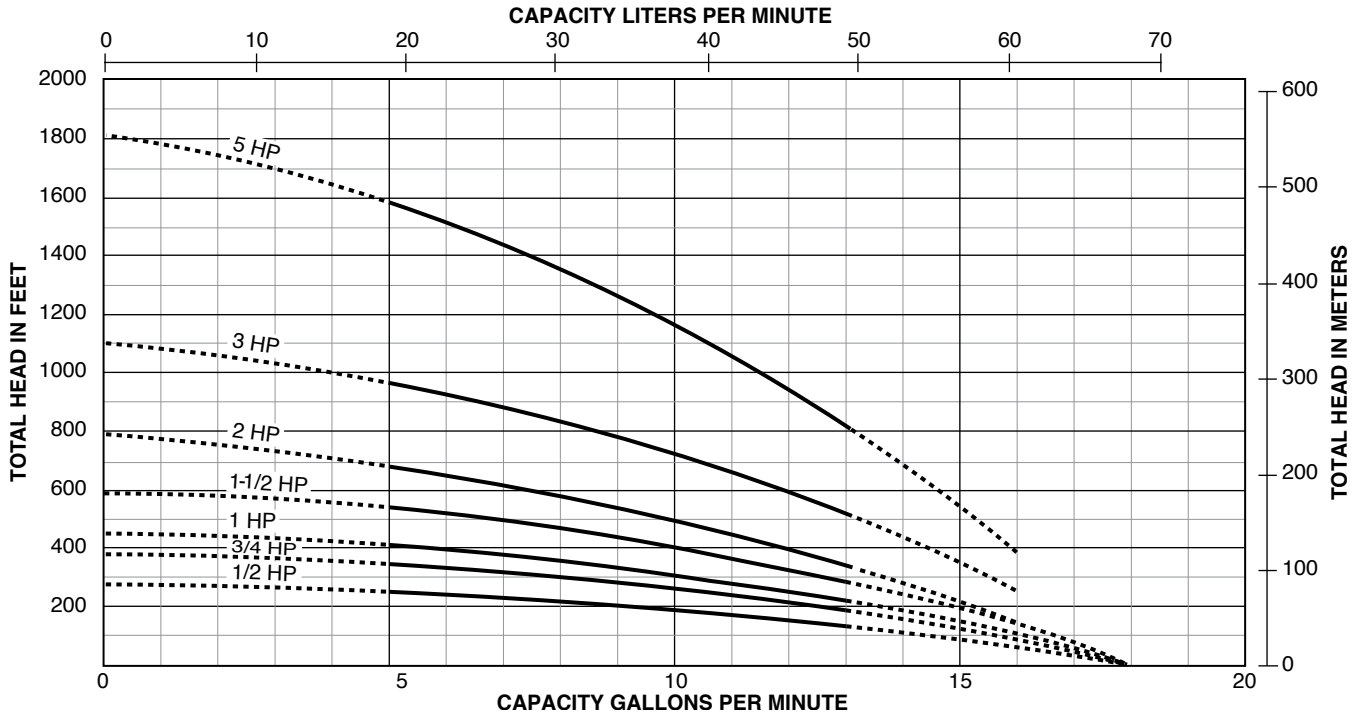

Tested and rated in accordance with Water Systems Council Standards.

NOTE: Pumps installed with a Pro-Source® tank require a 100 PSI relief valve. Pumps installed with a conventional tank require a 75 PSI relief valve. Relief valve must be capable of relieving entire flow of pump at relief pressure.

# HS Series Signature 2000®

Stainless Steel

## PUMP PERFORMANCE: 15 GPM

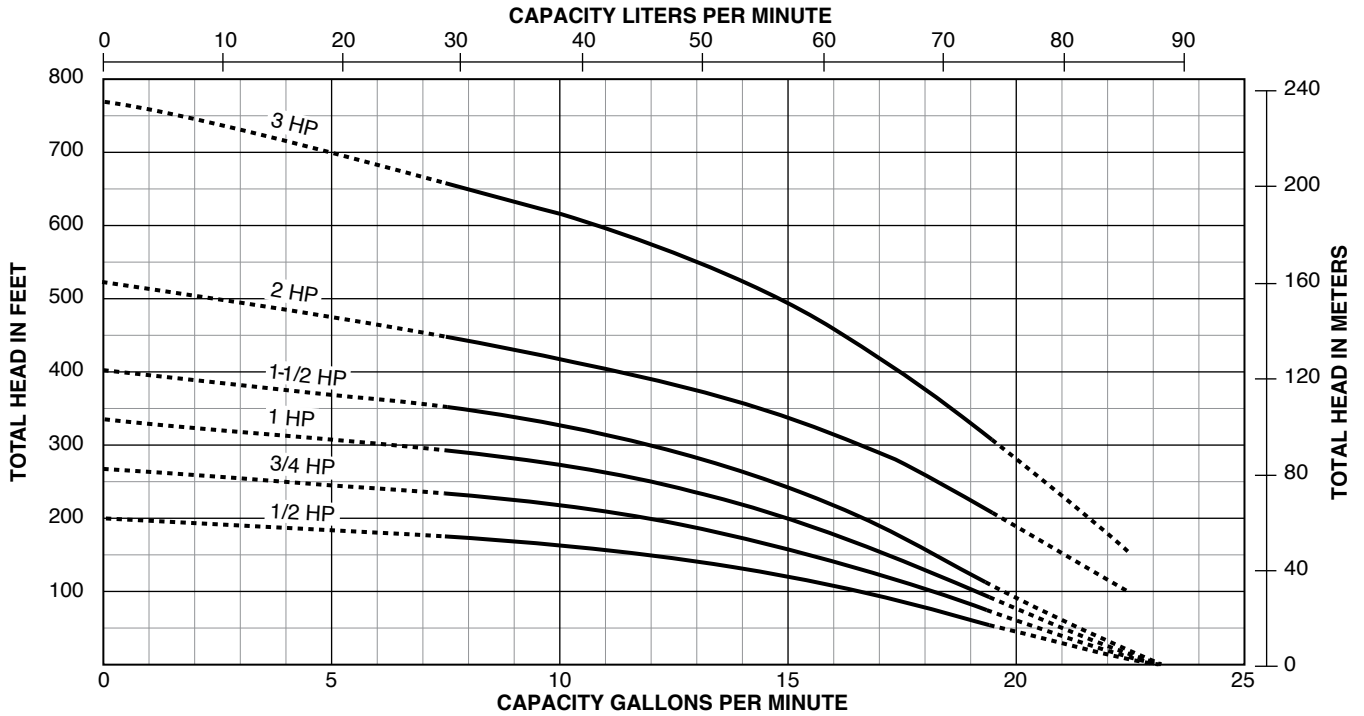

## PUMP PERFORMANCE: 20 GPM

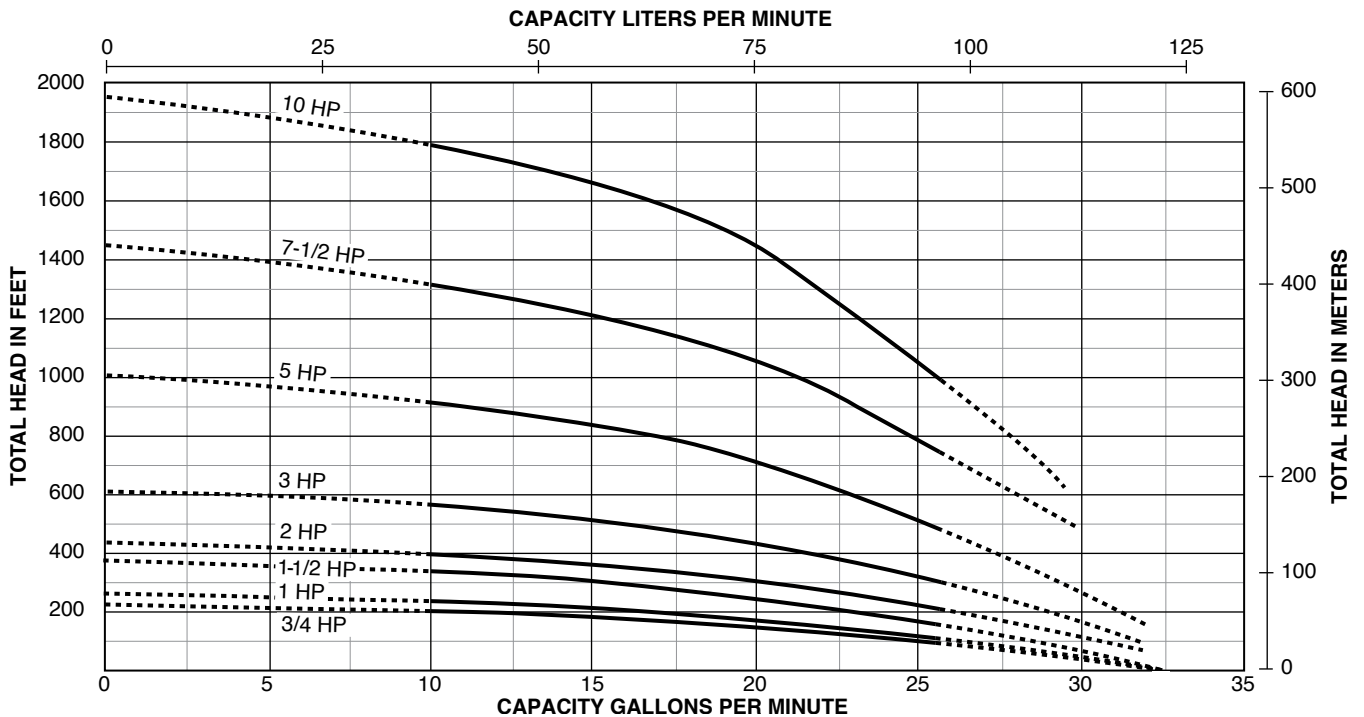

Tested and rated in accordance with Water Systems Council Standards.

NOTE: Pumps installed with a Pro-Source® tank require a 100 PSI relief valve. Pumps installed with a conventional tank require a 75 PSI relief valve. Relief valve must be capable of relieving entire flow of pump at relief pressure.

# HS Series Signature 2000®

Stainless Steel

## PUMP PERFORMANCE: 30 GPM

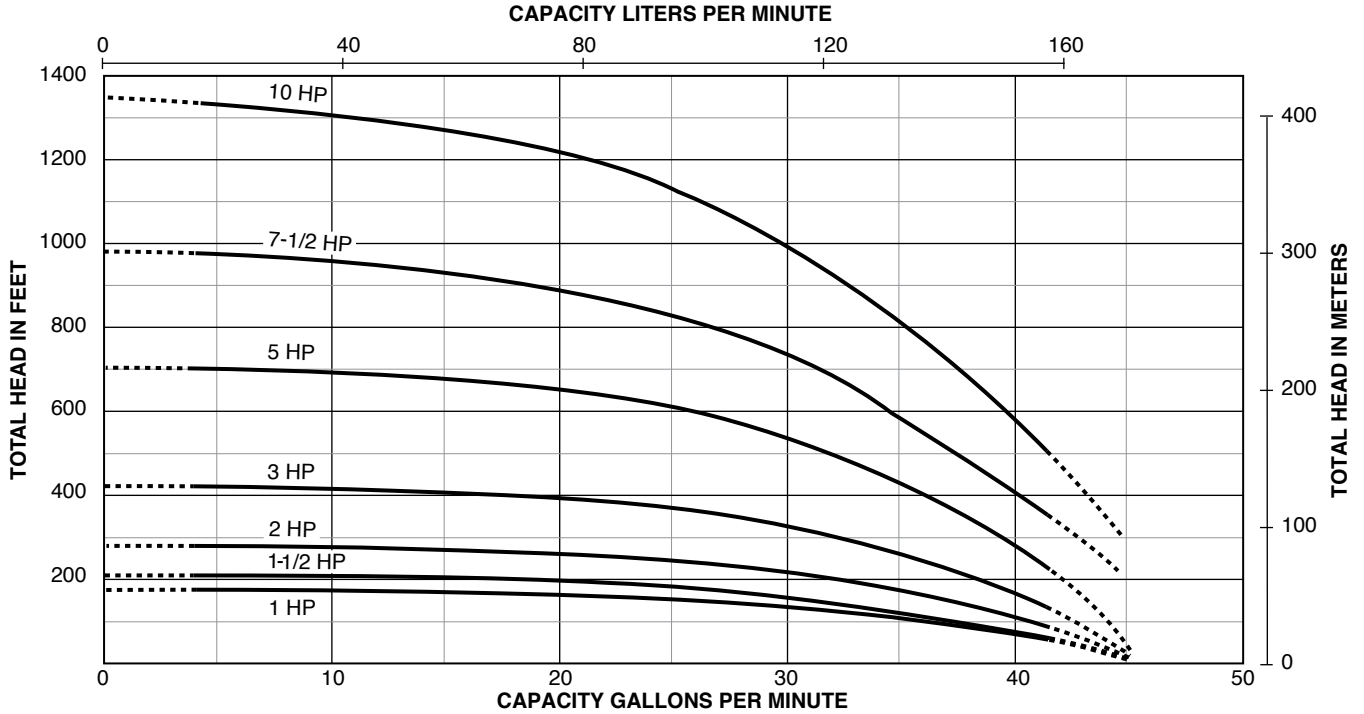

## PUMP PERFORMANCE: 50 GPM

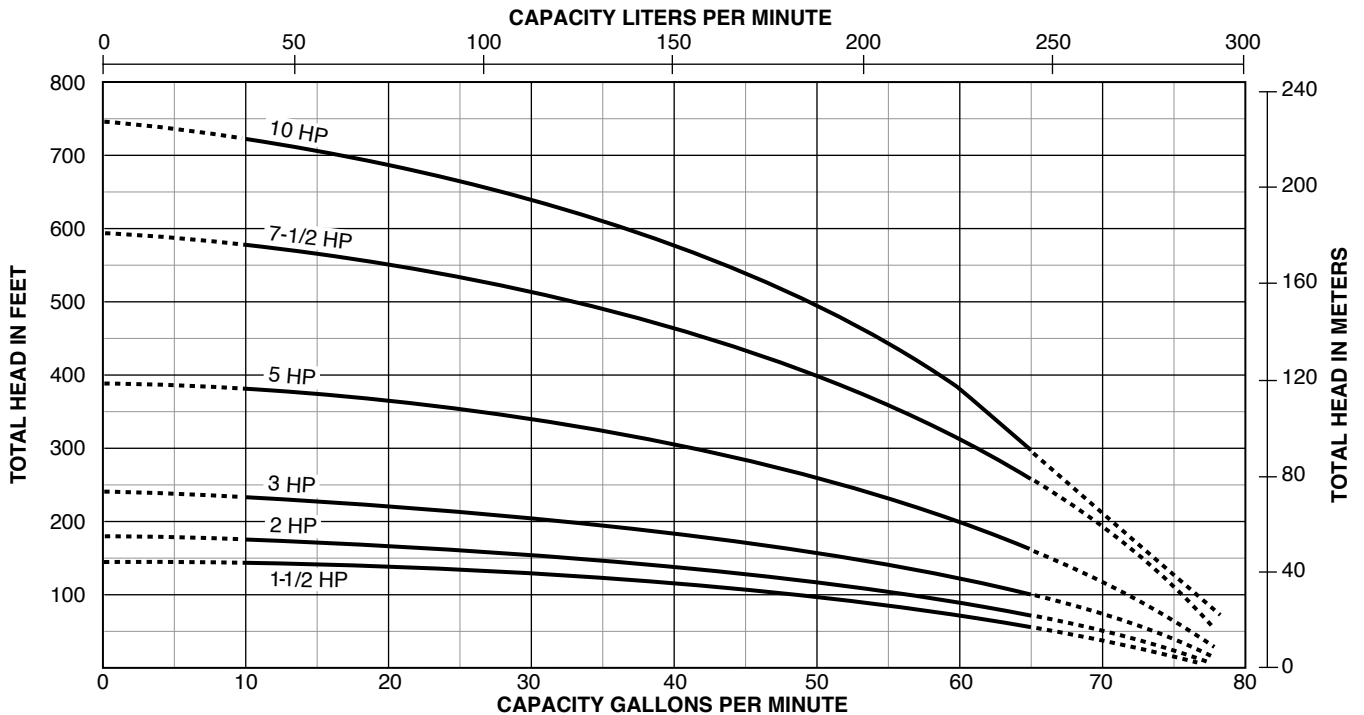

Tested and rated in accordance with Water Systems Council Standards.

NOTE: Pumps installed with a Pro-Source® tank require a 100 PSI relief valve. Pumps installed with a conventional tank require a 75 PSI relief valve. Relief valve must be capable of relieving entire flow of pump at relief pressure.



# HS Series Signature 2000®

Stainless Steel

15 GALLONS PER MINUTE		PUMP PERFORMANCE (Capacity in gallons per minute)																				SHUT-OFF HEAD					
HP	PSI	PUMPING DEPTH IN FEET																				FEET	PSI				
		0	20	40	60	80	100	120	140	160	180	200	220	240	260	280	300	320	340	360	380			400			
1/2	0	—	—	20.5	19.2	17.8	16.3	14.7	12.8	10.5	7.5												201	87			
	20	20.1	18.8	17.4	15.8	14.1	12.1	9.7	6.2																		
	30	18.6	17.1	15.6	13.8	11.8	9.2	5.5																			
	40	16.9	15.3	13.5	11.4	8.8	4.6																				
	50	15.1	13.2	11.0	8.3	3.4																					
	60	12.9	10.7	7.8																							
	70	10.3	7.2																								
	80	6.6																									
3/4	0	—	—	—	20.2	19.2	18.2	17.1	15.9	14.7	13.3	11.7	9.8	7.5	3.6								269	116			
	20	20.8	19.9	18.9	17.9	16.7	15.5	14.2	12.8	11.2	9.2	6.6															
	30	19.7	18.7	17.7	16.6	15.4	14.0	12.6	10.9	8.8	6.1																
	40	18.6	17.5	16.4	15.2	13.8	12.3	10.6	8.5	5.5																	
	50	17.3	16.2	15.0	13.6	12.1	10.3	8.1	4.8																		
	60	16.0	14.8	13.4	11.8	10.0	7.7	4.0																			
	70	14.5	13.1	11.5	9.7	7.3	3.0																				
	80	12.9	11.3	9.3	6.8																						
1	0	—	—	—	—	20.4	19.6	18.7	17.8	16.9	15.9	14.8	13.6	12.3	10.9	9.3	7.3	4.5					336	145			
	20	—	21.0	20.2	19.3	18.5	17.5	16.6	15.5	14.4	13.2	11.9	10.4	8.7	6.6	3.2											
	30	20.9	20.1	19.2	18.3	17.4	16.4	15.4	14.3	13.0	11.7	10.2	8.4	6.2	2.4												
	40	19.9	19.1	18.2	17.3	16.3	15.2	14.1	12.8	11.5	9.9	8.1	5.7														
	50	18.9	18.0	17.1	16.1	15.0	13.9	12.6	11.3	9.7	7.8	5.3															
	60	17.9	17.0	15.9	14.9	13.7	12.4	11.0	9.4	7.5	4.8																
	70	16.8	15.8	14.7	13.5	12.2	10.8	9.1	7.1	4.2																	
	80	15.6	14.5	13.3	12.0	10.6	8.8	6.7	3.6																		
1-1/2	0	—	—	—	—	20.5	19.9	19.2	18.5	17.8	17.1	16.3	15.5	14.7	13.7	12.8	11.7	10.5	9.1	7.5	5.3		403	174			
	20	—	20.9	20.3	19.7	19.0	18.3	17.6	16.9	16.1	15.3	14.4	13.4	12.4	11.3	10.1	8.7	6.9	4.3								
	30	20.8	20.2	19.6	18.9	18.2	17.5	16.7	16.0	15.1	14.2	13.3	12.3	11.2	9.9	8.4	6.6	3.8									
	40	20.1	19.5	18.8	18.1	17.4	16.6	15.8	15.0	14.1	13.1	12.1	11.0	9.7	8.2	6.2	3.0										
	50	19.4	18.7	18.0	17.3	16.5	15.7	14.9	14.0	13.0	11.9	10.8	9.5	7.9	5.9	1.8											
	60	18.6	17.9	17.1	16.4	15.6	14.7	13.8	12.8	11.8	10.6	9.2	7.6	5.5													
	70	17.8	17.0	16.3	15.4	14.6	13.7	12.7	11.6	10.4	9.0	7.3	5.1														
	80	16.9	16.1	15.3	14.4	13.5	12.5	11.4	10.2	8.8	7.0	4.6															
2	0	—	—	—	—	—	—	20.7	20.2	19.6	18.3	16.9	14.4	11.6	7.4	2.7							525	227			
	20	—	—	—	21.2	20.9	20.2	19.7	19.1	18.4	17.0	14.7	11.8	7.8	3.2												
	30	—	—	—	21.2	20.8	20.3	19.7	19.1	18.5	17.9	16.1	13.5	10.2	5.5												
	40	—	21.1	20.6	20.2	19.8	19.2	18.6	17.9	17.1	14.9	12.0	8.1	3.4													
	50	21.1	20.6	20.1	19.7	19.2	18.6	17.9	17.1	16.2	13.6	10.8	6.0														
	60	20.5	20.1	19.6	19.1	18.7	18.0	17.2	16.2	15.1	12.2	8.6	3.7														
3	0	—	—	—	—	—	—	—	—	21.0	20.2	19.5	18.7	17.8	16.6	15.0	13.0	10.8	8.0	4.9	1.6		770	333			
	20	—	—	—	—	—	—	21.1	20.8	20.3	19.5	18.8	17.9	16.7	15.1	13.2	11.1	8.3	5.2	1.9							
	30	—	—	—	—	—	21.2	20.8	20.3	19.9	19.2	18.3	17.4	16.1	14.3	12.2	10.4	7.0	3.5	3.6							
	40	—	—	—	21.6	21.2	20.9	20.4	19.9	19.6	18.8	18.0	16.8	15.2	13.4	11.2	8.4	5.4	2.1								
	50	—	—	21.6	21.1	20.9	20.4	20.0	19.7	19.2	18.4	17.5	16.2	14.4	12.3	10.5	7.1	3.8									
	60	—	21.4	21.1	20.8	20.5	20.0	19.7	19.3	18.9	18.0	16.9	15.3	13.5	11.4	8.8	5.5										

CAUTION: DO NOT use pump at flow rates indicated by the symbol '—'. To do so can cause premature failure of unit. Pump warranty void when failure occurs under these conditions.

Tested and rated in accordance with Water Systems Council Standards.

NOTE: Pumps installed with a Pro-Source® tank require a 100 PSI relief valve. Pumps installed with a conventional tank require a 75 PSI relief valve. Relief valve must be capable of relieving entire flow of pump at relief pressure.

# HS Series Signature 2000<sup>®</sup>

Stainless Steel

20 GALLONS PER MINUTE		PUMP PERFORMANCE (Capacity in gallons per minute)																				SHUT-OFF HEAD					
HP	PSI	PUMPING DEPTH IN FEET																				FEET	PSI				
		0	20	40	60	80	100	120	140	160	180	200	220	240	260	280	300	320	340	360	380			400			
3/4	0	—	—	—	—	26.9	25.0	23.0	20.7	18.1	15.1	11.3	4.9										225	97			
	20	—	—	26.3	24.4	22.3	19.9	17.3	14.1	9.8																	
	30	27.9	26.1	24.1	21.9	19.6	16.8	13.5	9.0																		
	40	25.8	23.8	21.6	19.2	16.4	12.9	8.0																			
	50	23.4	21.2	18.8	15.9	12.3	7.0																				
	60	20.9	18.3	15.4	11.6	5.7																					
	80	17.9	14.9	10.9	3.8																						
1	0	—	—	—	—	27.9	26.4	24.7	23.0	21.0	18.9	16.5	13.6	10.0	2.8								262	114			
	20	—	—	27.5	25.9	24.2	22.4	20.4	18.2	15.7	12.6	8.5															
	30	—	27.2	25.6	23.9	22.1	20.1	17.8	15.2	12.1	7.6																
	40	27.0	25.4	23.7	21.8	19.7	17.5	14.8	11.5	6.6																	
	50	25.1	23.4	21.5	19.4	17.1	14.3	10.9	5.5																		
	60	23.1	21.2	19.1	16.7	13.9	10.3	3.9																			
	80	20.9	18.7	16.3	13.4	9.6																					
1-1/2	0	—	—	—	—	—	—	27.9	26.8	25.6	24.4	23.1	21.7	20.2	18.6	16.9	15.0	12.7	10.0	6.1			375	162			
	20	—	—	—	—	27.5	26.4	25.2	24.0	22.6	21.3	19.8	18.1	16.3	14.3	12.0	9.0	4.1									
	30	—	—	—	27.4	26.2	25.0	23.8	22.4	21.0	19.5	17.9	16.0	14.0	11.6	8.4	2.6										
	40	—	—	27.2	26.0	24.8	23.6	22.2	20.8	19.3	17.6	15.7	13.6	11.1	7.8												
	50	—	27.0	25.8	24.6	23.4	22.0	20.6	19.0	17.3	15.4	13.3	10.7	7.2													
	60	26.8	25.7	24.4	23.2	21.8	20.3	18.8	17.0	15.1	12.9	10.2	6.5														
	80	24.1	22.7	21.4	19.9	18.2	16.5	14.5	12.2	9.2	4.7																

HP	PSI	PUMPING DEPTH IN FEET																		SHUT-OFF HEAD												
		20	40	60	80	100	125	150	175	200	250	300	350	400	450	500	550	600	650	700	750	800	850	900	950	1000	FEET	PSI				
2	0	—	—	—	—	—	—	—	27.3	26.0	23.2	20.2	16.2	8.5												450	194					
	20	—	—	—	—	—	—	—	26.1	24.9	23.4	20.6	16.7	9.5																		
	30	—	—	—	—	27.6	26.2	25.0	23.5	22.1	19.1	13.8	4.8																			
	40	—	—	—	27.5	26.4	25.1	23.7	22.2	20.8	17.2	10.1																				
	50	—	—	27.2	26.1	25.1	23.8	22.3	20.9	19.3	14.0	5.7																				
	60	—	27.1	26.0	25.0	23.9	22.4	21.0	19.4	17.3	10.8																					
3	0	—	—	—	—	—	—	—	—	27.2	25.3	23.5	21.3	19.1	16.0	11.3	3.6									605	349					
	20	—	—	—	—	—	—	—	—	27.3	25.4	23.6	21.6	19.3	16.1	12.0	5.0															
	30	—	—	—	—	—	—	—	—	27.4	26.6	24.8	22.7	20.6	18.1	14.5	9.0															
	40	—	—	—	—	—	—	—	27.5	26.7	25.5	23.8	21.7	19.6	16.8	12.5	5.3															
	50	—	—	—	—	—	—	—	27.6	26.7	25.6	24.9	22.8	20.8	18.5	15.0	9.5															
	60	—	—	—	—	27.7	26.8	25.7	24.9	23.9	21.8	19.8	16.9	12.7	5.6																	
5	0	—	—	—	—	—	—	—	—	—	—	—	—	27.5	26.5	25.2	24.0	22.8	21.5	20.2	18.9	17.0	14.3	11.0	6.8		1005	476				
	20	—	—	—	—	—	—	—	—	—	—	—	—	27.6	26.6	25.3	24.1	22.9	21.6	20.3	19.0	17.3	14.0	11.2	7.3							
	30	—	—	—	—	—	—	—	—	—	—	—	—	—	27.1	26.0	24.9	23.5	22.2	21.0	19.9	18.2	16.2	13.3	9.5	5.2						
	40	—	—	—	—	—	—	—	—	—	—	—	—	—	27.7	26.7	25.4	24.2	22.9	21.7	20.4	19.1	17.5	14.4	11.5	7.7			3.1			
	50	—	—	—	—	—	—	—	—	—	—	—	—	—	27.2	26.0	25.0	23.6	22.3	21.1	20.0	18.4	16.3	13.5	9.9	5.7						
	60	—	—	—	—	—	—	—	—	—	27.8	26.8	25.5	24.3	23.0	21.8	20.5	19.2	17.7	14.9	12.0	8.0	3.7									

HP	PSI	PUMPING DEPTH IN FEET																SHUT-OFF HEAD													
		200	300	400	500	600	700	800	900	1000	1100	1200	1300	1400	1500	1600	FEET	PSI													
7-1/2	0	—	—	—	—	—	—	—	—	27.3	25.7	24.3	23.1	21.5	19.9	16.4	11.3	4.1							1450	628					
	20	—	—	—	—	—	—	—	—	26.7	25.3	23.7	22.3	20.8	18.9	14.7	8.5														
	30	—	—	—	—	—	—	—	—	—	26.5	25.1	23.5	22.1	20.6	18.3	13.4	7.0													
	40	—	—	—	—	—	—	—	—	—	27.5	26.3	24.7	23.3	21.7	20.2	17.3	12.1	5.3												
	50	—	—	—	—	—	—	—	—	—	27.3	25.7	24.5	22.7	21.3	19.7	16.0	10.6	3.6												
	60	—	—	—	—	—	—	—	—	—	26.9	25.5	24.3	22.5	21.0	19.3	15.1	9.5													
10	0	—	—	—	—	—	—	—	—	—	—	—	—	—	26.8	25.7	24.7	23.7	22.6	21.6	20.7	19.5	17.1			1950	844				
	20	—	—	—	—	—	—	—	—	—	—	—	—	—	27.5	26.4	25.3	24.4	23.3	22.1	21.3	20.1	18.5	16.0							
	30	—	—	—	—	—	—	—	—	—	—	—	—	—	27.3	26.2	25.0	24.1	23.0	21.9	21.0	19.9	18.0	15.0							
	40	—	—	—	—	—	—	—	—	—	—	—	—	—	27.0	25.7	24.9	24.0	22.8	21.7	20.8	19.7	17.6	14.7							
	50	—	—	—	—	—	—	—	—	—	—	—	—	—	27.8	26.7	25.5	24.7	23.6	22.5	21.5	20.6	19.4	17.0	14.0						
	60	—	—	—	—	—	—	—	—	—	—	—	—	—	27.5	26.4	25.3	24.4	23.3	22.2	21.3	20.2	18.5	16.1	12.5						

CAUTION: DO NOT use pump at flow rates indicated by the symbol '—'. To do so can cause premature failure of unit. Pump warranty void when failure occurs under these conditions. Tested and rated in accordance with Water Systems Council Standards.

NOTE: Pumps installed with a Pro-Source<sup>®</sup> tank require a 100 PSI relief valve. Pumps installed with a conventional tank require a 75 PSI relief valve. Relief valve must be capable of relieving entire flow of pump at relief pressure.

# HS Series Signature 2000®

Stainless Steel

30 GALLONS PER MINUTE		PUMP PERFORMANCE (Capacity in gallons per minute)																						
HP	PSI	PUMPING DEPTH IN FEET																		SHUT-OFF HEAD				
		20	40	60	80	100	125	150	175	200	250	300	350	400	450	500	550	600	650	700	FEET	PSI		
1	0	—	42.5	40.9	39.1	36.8	32.5	26.0	8.0												175	76		
	20	40.4	38.8	36.0	32.4	27.7	13.3																	
	30	38.0	35.3	31.7	26.3	14.3																		
	40	35.0	31.4	25.9	12.1																			
	50	30.2	24.0	3.0																				
	60	21.9																						
1-1/2	0	—	—	41.9	39.9	37.5	34.1	30.9	26.9	17.0											210	91		
	20	41.2	39.1	36.5	34.0	31.5	27.8	21.5																
	30	38.9	36.1	33.8	31.0	27.9	21.8																	
	40	36.0	33.5	30.8	27.7	20.2																		
	50	32.9	30.1	26.8	21.5																			
	60	29.5	25.9	18.1																				
2	0	—	—	—	41.8	40.5	38.8	36.8	34.7	31.6	23.7										280	121		
	20	—	41.3	40.1	38.7	37.1	34.9	32.1	29.0	24.8														
	30	41.2	40.0	38.5	37.0	35.0	32.2	29.1	24.9	15.2														
	40	39.9	38.3	36.6	34.8	32.7	29.8	25.1	16.1															
	50	38.0	36.3	34.5	32.1	30.0	25.3	17.5																
	60	36.0	34.0	31.9	29.1	26.0	18.0																	
3	0	—	—	—	—	42.7	41.6	40.1	39.6	38.2	35.5	32.0	27.3								420	182		
	20	—	—	42.4	41.5	41.0	39.8	38.5	37.1	35.7	32.1	28.0	18.5											
	30	42.9	42.2	41.3	40.6	39.9	38.7	37.2	35.8	34.2	30.3	24.9	6.0											
	40	42.1	41.2	40.4	39.7	38.8	37.3	35.9	34.5	32.6	28.3	19.9												
	50	41.1	40.3	39.5	38.5	37.4	36.0	34.6	32.7	31.0	25.2	9.5												
	60	40.2	39.3	38.3	37.2	36.1	34.7	32.8	31.0	28.5	20.5													
5	0	—	—	—	—	—	—	—	42.6	42.0	40.7	39.2	38.0	36.0	34.2	31.9	29.2	26.0	20.0		705	305		
	20	—	—	—	—	—	42.7	42.0	41.3	40.8	39.3	38.2	36.2	34.4	32.4	30.0	26.1	21.5						
	30	—	—	—	—	42.8	42.1	41.4	40.8	40.1	38.7	37.0	35.1	33.1	31.1	26.0	24.1	16.0						
	40	—	—	—	—	42.1	41.5	40.9	40.2	39.3	37.9	36.1	34.3	32.0	29.4	26.2	20.4							
	50	—	—	42.6	42.0	41.5	41.2	40.2	39.5	38.8	37.1	35.4	33.2	31.2	28.8	24.5	16.0							
	60	—	42.5	42.0	41.4	41.1	40.3	39.8	38.9	38.1	36.2	34.2	32.1	30.0	26.7	22.0								
HP	PSI	PUMPING DEPTH IN FEET														SHUT-OFF HEAD								
		200	300	400	500	600	700	800	900	1000	1100	1200	1300	1400	FEET	PSI								
7-1/2	0	—	—	40.4	37.6	34.8	32.0	28.1	20.0												975	422		
	20	—	42.0	39.3	36.5	33.8	30.5	25.5	13.8															
	30	—	41.3	38.6	35.8	33.1	29.8	23.3	6.5															
	40	—	40.7	38.1	35.6	32.6	29.3	21.7																
	50	42.7	40.1	37.3	34.6	31.7	27.4	19.3																
	60	42.0	39.4	36.5	33.7	30.7	25.1	13.9																
10	0	—	—	—	41.3	39.5	37.3	35.1	33.1	30.4	27.1	22.5	11.9								1345	582		
	20	—	—	42.3	40.5	38.6	36.4	34.5	31.8	29.2	25.3	18.7												
	30	—	—	42.0	40.1	43.0	35.7	33.7	31.3	28.4	24.2	16.3												
	40	—	—	41.6	39.7	37.7	35.5	33.5	30.9	27.7	23.4	14.4												
	50	—	42.7	41.0	39.3	37.1	34.9	32.8	30.2	26.7	21.7	7.7												
	60	—	42.3	40.6	38.7	36.5	34.5	32.3	29.5	25.7	20.1	5.0												

CAUTION: DO NOT use pump at flow rates indicated by the symbol '—'. To do so can cause premature failure of unit. Pump warranty void when failure occurs under these conditions. Tested and rated in accordance with Water Systems Council Standards.

NOTE: Pumps installed with a Pro-Source® tank require a 100 PSI relief valve. Pumps installed with a conventional tank require a 75 PSI relief valve. Relief valve must be capable of relieving entire flow of pump at relief pressure.

# HS Series Signature 2000®

Stainless Steel

50 GALLONS PER MINUTE																	PUMP PERFORMANCE (Capacity in gallons per minute)		
HP	PSI	PUMPING DEPTH IN FEET															SHUT-OFF HEAD		
		20	40	60	80	100	125	150	175	200	250	300	350	450	550	650	700	FEET	PSI
1-1/2	0	—	—	—	58.2	49.3	33.5											145	63
	20	—	55.9	46.5	32.5														
	30	54.8	45.0	30.0															
	40	43.3	26.9																
	50	21.9																	
	60																		
2	0	—	—	—	63.3	57.0	47.8	33.9										180	78
	20	—	62.2	55.1	46.8	37.1	13.0												
	30	61.1	53.6	46.0	34.3	14.1													
	40	52.8	45.0	32.5	11.0														
	50	42.7	27.9																
	60	25.2																	
3	0	—	—	—	—	64.5	59.4	52.5	45.0	33.8								235	102
	20	—	—	63.7	59.0	53.5	46.5	36.2	18.2										
	30	—	62.9	58.1	53.0	47.0	37.0	20.5											
	40	62.5	57.6	52.0	46.2	38.8	22.1												
	50	56.5	51.0	44.7	36.2	22.8													
	60	50.0	43.7	34.0	20.5														
5	0	—	—	—	—	—	—	65.9	63.2	59.9	51.9	41.9	22.5					385	166
	20	—	—	—	—	—	63.5	60.8	56.1	52.4	42.5	24.9							
	30	—	—	—	—	63.8	60.9	56.9	53.0	47.9	35.5	12.9							
	40	—	—	65.5	63.2	61.0	57.0	53.2	48.0	43.5	27.0								
	50	—	65.1	63.0	60.8	57.1	53.3	48.1	43.6	36.4	14.2								
	60	64.9	62.4	60.0	56.9	53.7	48.7	44.1	37.5	28.0									
7-1/2	0	—	—	—	—	—	—	—	—	—	66.0	61.0	55.3	43.1	20.0			595	257
	20	—	—	—	—	—	—	—	—	64.8	61.1	56.0	50.0	34.9					
	30	—	—	—	—	—	—	—	64.9	63.3	58.7	53.2	47.2	28.8					
	40	—	—	—	—	—	—	65.0	63.6	61.7	56.2	50.9	44.1	22.0					
	50	—	—	—	—	—	65.1	63.7	61.8	58.9	53.9	47.5	41.0	13.2					
	60	—	—	—	—	65.2	63.8	61.9	59.0	56.5	51.1	44.9	36.0						
10	0	—	—	—	—	—	—	—	—	—	65.0	62.1	54.2	44.7	29.0	15.2		745	322
	20	—	—	—	—	—	—	—	—	—	65.5	62.5	59.1	50.1	39.2	17.1			
	30	—	—	—	—	—	—	—	—	66.9	64.1	61.2	56.9	47.5	35.0	10.5			
	40	—	—	—	—	—	—	—	67.0	65.8	63.0	59.3	54.9	45.2	30.5				
	50	—	—	—	—	—	—	67.1	65.9	64.2	61.5	57.2	53.0	42.9	25.0				
	60	—	—	—	—	—	67.2	66.0	64.3	63.2	59.9	55.0	51.0	40.6	19.7				

CAUTION: DO NOT use pump at flow rates indicated by the symbol '—'. To do so can cause premature failure of unit. Pump warranty void when failure occurs under these conditions.

Tested and rated in accordance with Water Systems Council Standards.

NOTE: Pumps installed with a Pro-Source® tank require a 100 PSI relief valve. Pumps installed with a conventional tank require a 75 PSI relief valve. Relief valve must be capable of relieving entire flow of pump at relief pressure.

# JP Series Signature 2000®

Composite, 5 and 7 GPM TrimLine™



POWERED BY  
**PENTEK®**



**Precision-engineered, corrosion-resistant Signature 2000® Composite Pumps in 5 and 7 GPM deliver efficient, dependable performance even in rough, aggressive water. Heads to over 850 feet and capacities to 10 GPM. Built to deliver long-term, trouble-free service.**

**These pumps feature the proven SignaSeal™ staging system. Floating stack design resists sand and reduces sand locking.**

**The 5 and 7 GPM models are the smaller 3-3/4" diameter TrimLine.**

## APPLICATIONS

**Water systems...**for residential, industrial, commercial, multiple housing and farm use.

## SPECIFICATIONS

**Shell:** Stainless steel

**Discharge:** Fiberglass-reinforced thermoplastic

**Discharge Bearing:** Nylatron®

**Intermediate Bearing:** (On larger units) polycarbonate, nitrile rubber and stainless steel

**Impellers:** Acetal

**Diffusers:** Polycarbonate

**Suction Caps:** Polycarbonate with stainless steel insert

**Thrust Pads:** Proprietary spec.

**Shaft and Coupling :** Stainless steel

**Intake:** Fiberglass-reinforced thermoplastic

**Intake Screen:** Polypropylene

**Cable Guard:** Stainless steel

**Agency Listings:** CSA

**Check Valve:** Spring-loaded check valve

## FEATURES

### Proven Staging System:

Our proven SignaSeal staging system incorporates a harder-than-sand ceramic wear surface that when incorporated with our floating impeller design, greatly reduces problems with abrasives, sand lock-up and running dry.

**Discharge:** Corrosion-resistant fiberglass-reinforced thermoplastic for durability in aggressive water. Large octagon wrench area for ease of installation.

**Discharge Bearing:** Exclusive self-lubricating Nylatron bearing resists wear from sand.

**Intake:** Corrosion-resistant fiberglass-reinforced thermoplastic for durability in aggressive water.

**Shaft:** Positive drive from 7/16" hexagonal heavy-duty 300 grade stainless steel.

**Coupling:** Stainless steel press fit to pump shaft. Couples to all standard NEMA motors.

**Shell:** Crimped shell.

**Hardware:** All screws, washers and nuts are corrosion-resistant 300 grade stainless steel.

**Check Valve:** Spring-loaded check valve.

**Cable Guard:** Corrosion-resistant stainless steel guard protects motor leads. Tapered ends prevent pump from catching on well.

**Intake Screen:** Molded-in screen.

### Pentek® XE Series™ Motor:

2 and 3 wire NEMA standard all stainless construction water-filled motors.

# JP Series Signature 2000®

Composite, 5 and 7 GPM TrimLine™

## ORDERING INFORMATION

GPM	MOTOR TYPE	HP	STGS.	PH†	VOLT	ASSEMBLED PUMP			PUMP END			MOTOR		CONTROL BOX	
						CATALOG NUMBER	LENGTH INCHES*	WEIGHT POUNDS*	CATALOG NUMBER	LENGTH INCHES*	WEIGHT POUNDS*	CATALOG NUMBER	WEIGHT POUNDS*	CATALOG NUMBER	WEIGHT POUNDS*
5	2 WIRE	1/2	14	1	115	S5P4JP05121	28	28	L5P4CJL	18	12	P42B0005A1	19		
		1/2	14	1	230	S5P4JP05221	28	28	L5P4CJL	18	12	P42B0005A2	19		
		3/4	19	1	230	S5P4JP07221	33	34	L5P4DJL	22	15	P42B0007A2	23		
		1	22	1	230	S5P4JP10221	37	39	L5P4EJL	26	17	P42B0010A2	25		
	3 WIRE	1/2	13	1	115	S5P4JP05131	27-1/2	29	L5P4CJL	18	12	P43B0005A1	19	SMC-IR0511	4
		1/2	14	1	230	S5P4JP05231	28	28	L5P4CJL	18	12	P43B0005A2	18	SMC-CR0521	4
		3/4	19	1	230	S5P4JP07231	33	34	L5P4DJL	22	15	P43B0007A2	21	SMC-CR0721	4
		1	22	1	230	S5P4JP10231	37	39	L5P4EJL	26	17	P43B0010A2	23	SMC-CR1021	4
		1	22	3	230				L5P4EJL	25-1/4	17	P43B0010A3	23		
		1	22	3	460				L5P4EJL	25-1/4	17	P43B0010A4	23		
7	2 WIRE	1/2	11	1	115	S7P4JP05121	26	27	L7P4CJL	16	11	P42B0005A1	19		
		1/2	11	1	230	S7P4JP05221	26	27	L7P4CJL	16	11	P42B0005A2	19		
		3/4	15	1	230	S7P4JP07221	30	32	L7P4DJL	19	13	P42B0007A2	23		
		1	18	1	230	S7P4JP10221	34	37	L7P4EJL	22	15	P42B0010A2	25		
		1-1/2	22	1	230	S7P4JP15221	43	47	L7P4FJL	28	21	P42B0015A2	29		
	3 WIRE	1/2	10	1	115	S7P4JP05131	25-1/2	27	L7P4CJL	16	12	P43B0005A1	19	SMC-IR0511	4
		1/2	11	1	230	S7P4JP05231	26	27	L7P4CJL	16	11	P43B0005A2	18	SMC-CR0521	4
		3/4	15	1	230	S7P4JP07231	29	32	L7P4DJL	19	13	P43B0007A2	21	SMC-CR0721	4
		1	17	3	230				L7P4EJL	22	17	P43B0010A3	23	SMC-CR1021	4
		1	17	3	460				L7P4EJL	22	17	P43B0010A4	23		
		1-1/2	22	1	230	S7P4JP15231	41	44	L7P4FJL	27-1/4	21	P43B0015A2	27		
		1-1/2	22	3	230				L7P4FJL	27-1/4	21	P43B0015A3	23	SMC-CR1521	7
		1-1/2	22	3	460				L7P4FJL	27-1/4	21	P43B0015A4	23		

†For all Pentek XE series three-phase motor options, see page 65.

\*Length and Weight are approximate.

TrimLine™ version maximum outside diameter is 3-3/4". Standard version maximum outside diameter is 3-7/8".

NOTE: Motor, Control Box or Magnetic Starter must be ordered separately. Discharge NPT is 1-1/4".

# JP Series Signature 2000®

Composite, 5 and 7 GPM TrimLine™

## OUTLINE DIMENSIONS

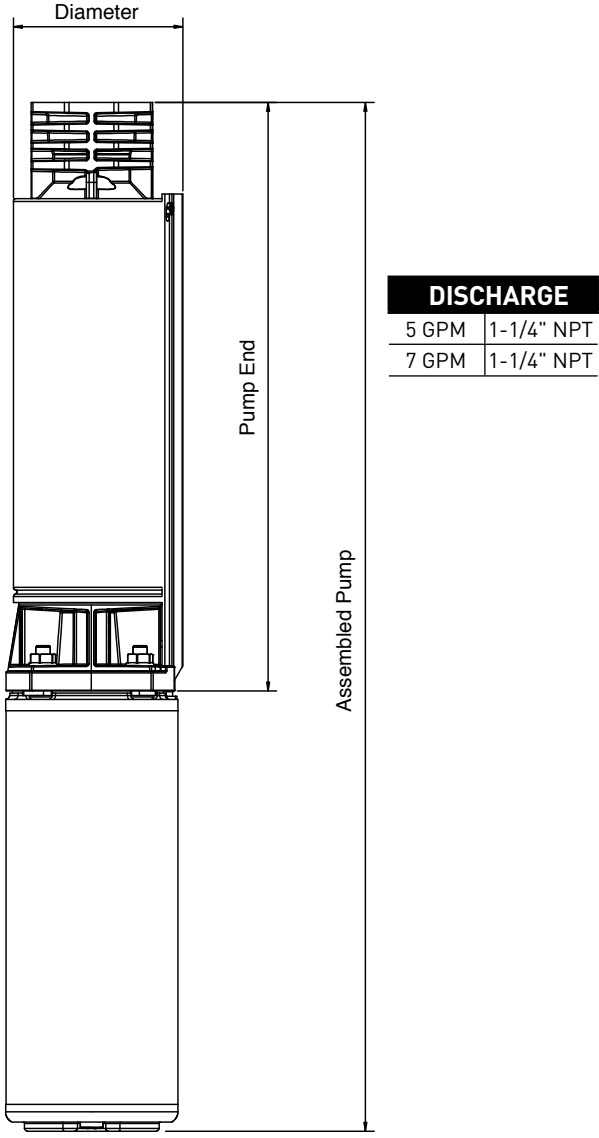

For dimensions, refer to Ordering Information table.  
Dimensions (in inches) are for estimating purposes only.

# JP Series Signature 2000®

Composite, 5 and 7 GPM TrimLine™

## PUMP PERFORMANCE: 5 GPM

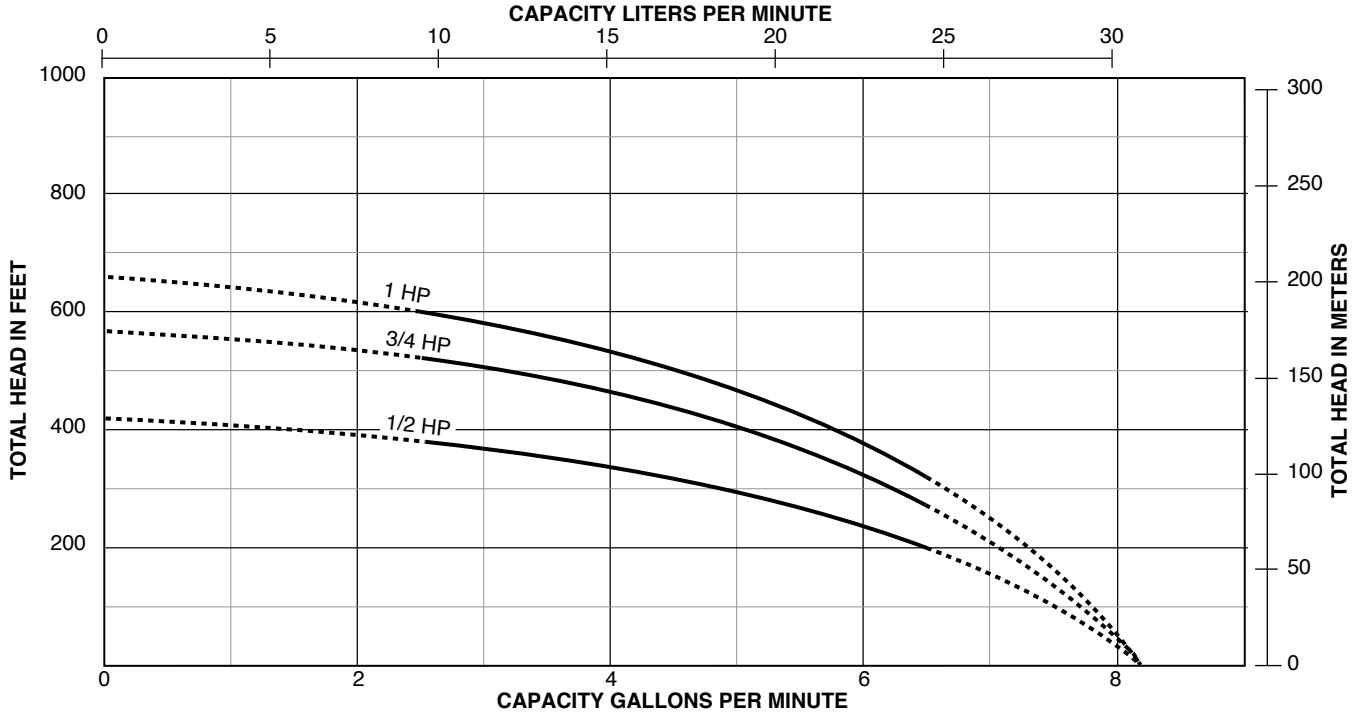

## PUMP PERFORMANCE: 7 GPM

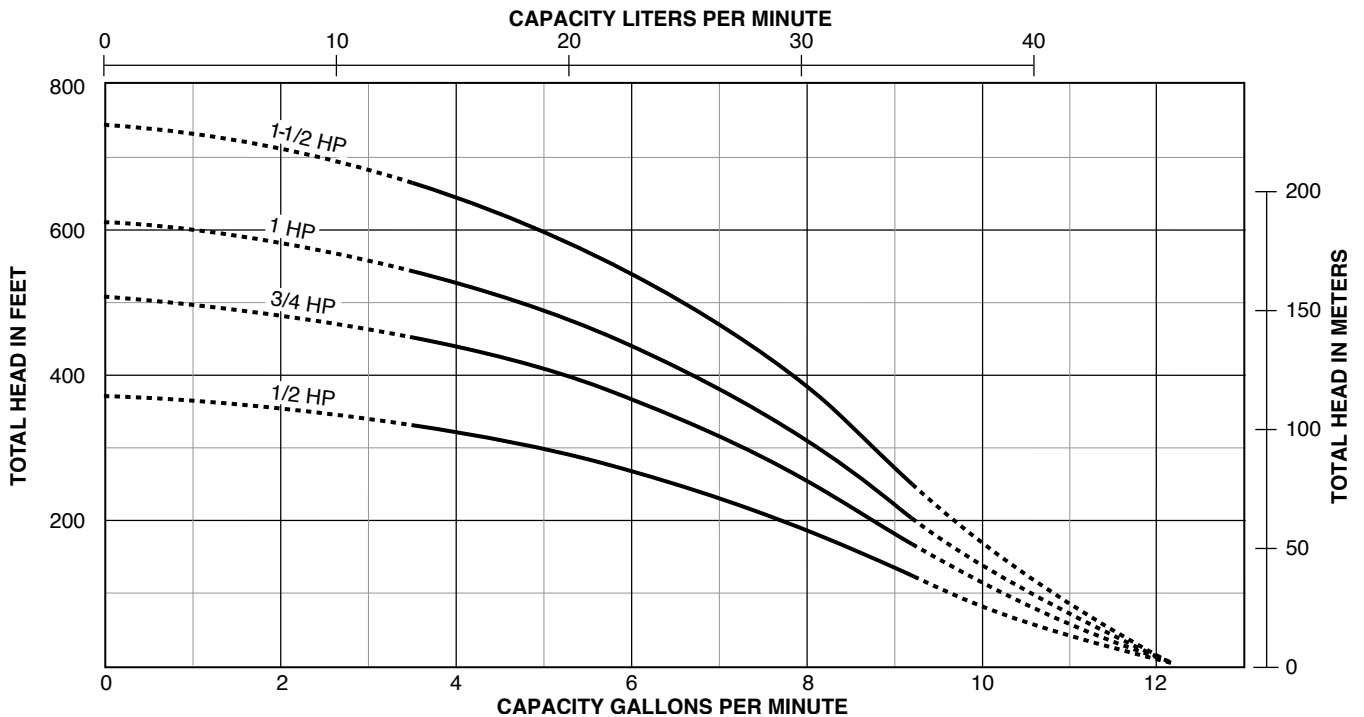

Tested and rated in accordance with Water Systems Council Standards.

NOTE: Pumps installed with a Pro-Source® tank require a 100 PSI relief valve. Pumps installed with a conventional tank require a 75 PSI relief valve. Relief valve must be capable of relieving entire flow of pump at relief pressure.





# JP Series Signature 2000®

Composite



POWERED BY  
**PENTEK®**



Precision-engineered, corrosion-resistant Signature 2000® Composite Pumps in 10, 15, 20 and 30 GPM deliver efficient, dependable performance even in rough, aggressive water. Heads to over 650 feet and capacities to 45 GPM. Built to deliver long-term, trouble-free service.

These pumps feature the proven SignaSeal™ staging system. Floating impeller design resists sand and reduces sand locking.

## APPLICATIONS

**Water systems...**for residential, industrial, commercial, multiple housing and farm use.

## SPECIFICATIONS

**Shell:** Stainless steel

**Diameter:** 3-7/8"

**Discharge:** Fiberglass-reinforced thermoplastic

**Discharge Bearing:** Nylatron®

**Intermediate Bearing:** (On larger units) polycarbonate, nitrile rubber and stainless steel

**Impellers:** Acetal

**Diffusers:** Polycarbonate

**Suction Caps:** Polycarbonate with stainless steel insert

**Thrust Pads:** Proprietary spec.

**Shaft and Coupling:** Stainless steel

**Intake:** Fiberglass-reinforced thermoplastic

**Intake Screen:** Polypropylene

**Cable Guard:** Stainless steel

**Check Valve:** Spring-loaded check valve

**Agency Listings:** CSA

## FEATURES

**Proven Staging System:** Our proven SignaSeal staging system incorporates a harder-than-sand ceramic wear surface that when incorporated with our floating impeller design, greatly reduces problems with abrasives, sand lock-up and running dry.

**Discharge:** Corrosion-resistant fiberglass-reinforced thermoplastic for durability in aggressive water. Large octagon wrench area for ease of installation.

**Discharge Bearing:** Exclusive self-lubricating Nylatron bearing resists wear from sand.

**Intake:** Corrosion-resistant fiberglass-reinforced thermoplastic for durability in aggressive water.

**Shaft:** Positive drive from 7/16" hexagonal heavy-duty 300 grade stainless steel.

**Coupling:** Stainless steel press fit to pump shaft. Couples to all standard NEMA motors.

**Shell:** Crimped shell.

**Hardware:** All screws, washers and nuts are corrosion-resistant 300 grade stainless steel.

**Check Valve:** Spring-loaded check valve.

**Cable Guard:** Corrosion-resistant stainless steel guard protects motor leads. Tapered ends prevent pump from catching on well.

**Intake Screen:** Molded-in screen.

**Pentek® XE Series™ Motor:**

2 and 3 wire NEMA standard all stainless construction water-filled motors.

# JP Series Signature 2000®

Composite

## ORDERING INFORMATION

GPM	MOTOR TYPE	HP	STGS.	PH†	VOLT	ASSEMBLED PUMP			PUMP END			MOTOR		CONTROL BOX	
						CATALOG NUMBER	LENGTH INCHES*	WEIGHT POUNDS*	CATALOG NUMBER	LENGTH INCHES*	WEIGHT POUNDS*	CATALOG NUMBER	WEIGHT POUNDS*	CATALOG NUMBER	WEIGHT POUNDS*
10**	2 WIRE	1/2	8	1	115	S10P4JP05121	23	28	L10P4CJ	13	9	P42B0005A1	19		
		1/2	8	1	230	S10P4JP05221	23	28	L10P4CJ	13	9	P42B0005A2	19		
		3/4	11	1	230	S10P4JP07221	26	31	L10P4DJ	15	10	P42B0007A2	23		
		1	13	1	230	S10P4JP10221	29	35	L10P4EJ	17	11	P42B0010A2	25		
		1-1/2	17	1	230	S10P4JP15221	35	42	L10P4FJ	20	12	P42B0015A2	29		
	3 WIRE	1/2	7	1	115	S10P4JP05131	22-3/4	27-1/2	L10P4CJ	12-3/4	9	P43B0005A1	19	SMC-IR0511	4
		1/2	8	1	230	S10P4JP05231	23	28	L10P4CJ	13	9	P43B0005A2	19	SMC-CR0521	4
		3/4	11	1	230	S10P4JP07231	26	31	L10P4DJ	15	10	P43B0007A2	21	SMC-CR0721	4
		1	13	1	230	S10P4JP10231	29	35	L10P4EJ	17	11	P43B0010A2	23	SMC-CR1021	4
		1	13	3	230				L10P4EJ	15-1/2	10-1/4	P43B0010A3	23		
		1	13	3	460				L10P4EJ	15-1/2	10-1/4	P43B0010A4	23		
		1-1/2	17	1	230	S10P4JP15231	34	42	L10P4FJ	20	12	P43B0015A2	27	SMC-CR1521	7
		1-1/2	17	3	230				L10P4FJ	19-3/4	12-1/2	P43B0015A3	23		
		1-1/2	17	3	460				L10P4FJ	19-3/4	12-1/2	P43B0015A4	23		
15**	2 WIRE	1/2	6	1	115	S15P4JP05121	23	27	L15P4CJ	13	9	P42B0005A1	19		
		1/2	6	1	230	S15P4JP05221	23	27	L15P4CJ	13	9	P42B0005A2	19		
		3/4	8	1	230	S15P4JP07221	26	31	L15P4DJ	15	10	P42B0007A2	23		
		1	10	1	230	S15P4JP10221	30	35	L15P4EJ	17	11	P42B0010A2	25		
		1-1/2	12	1	230	S15P4JP15221	36	43	L15P4FJ	21	13	P42B0015A2	29		
	3 WIRE	1/2	5	1	115	S15P4JP05131	22-1/4	27	L15P4CJ	12-1/4	9	P43B0005A1	19	SMC-IR0511	4
		1/2	6	1	230	S15P4JP05231	23	27	L15P4CJ	13	9	P43B0005A2	19	SMC-CR0521	4
		3/4	8	1	230	S15P4JP07231	26	31	L15P4DJ	15	10	P43B0007A2	21	SMC-CR0721	4
		1	10	1	230	S15P4JP10231	30	35	L15P4EJ	17	11	P43B0010A2	23	SMC-CR1021	4
		1	9	3	230				L15P4EJ	15-1/2	10-1/4	P43B0010A3	23		
		1	9	3	460				L15P4EJ	15-1/2	10-1/4	P43B0010A4	23		
		1-1/2	12	1	230	S15P4JP15231	34	41	L15P4FJ	21	13	P43B0015A2	27	SMC-CR1521	7
		1-1/2	12	3	230				L15P4FJ	20-1/4	13	P43B0015A3	23		
		1-1/2	12	3	460				L15P4FJ	20-1/4	13	P43B0015A4	23		
20**	2 WIRE	3/4	6	1	230	S20P4JP07221	23-3/4	30	L20P4DJ	13	9	P42B0007A2	23		
		1	7	1	230	S20P4JP10221	27-1/4	34	L20P4EJ	15	10	P42B0010A2	25		
		1-1/2	10	1	230	S20P4JP15221	32	39	L20P4FJ	17	11	P42B0015A2	29		
		3/4	6	1	230	S20P4JP07231	23-3/4	30	L20P4DJ	13	9	P43B0007A2	23	SMC-CR0721	4
	3 WIRE	1	7	1	230	S20P4JP10231	27-1/4	34	L20P4EJ	15	10	P43B0010A2	25	SMC-CR1021	4
		1	7	3	230				L20P4EJ	15-1/2	10-1/4	P43B0010A3	23		
		1	7	3	460				L20P4EJ	15-1/2	10-1/4	P43B0010A4	23		
		1-1/2	10	1	230	S20P4JP15231	30-1/2	39	L20P4FJ	17	11	P43B0015A2	29	SMC-CR1521	7
		1-1/2	9	3	230				L20P4FJ	16-3/4	10-3/4	P43B0015A3	23		
		1-1/2	9	3	460				L20P4FJ	16-3/4	10-3/4	P43B0015A4	23		
		2	12	1	230				L20P4GJ	20-1/4	12-1/2	P43B0020A2	31	SMC-CR2021	7
		2	12	3	230				L20P4GJ	20-1/4	12-1/2	P43B0020A3	23		
		2	12	3	460				L20P4GJ	20-1/4	12-1/2	P43B0020A4	23		
		30**	2 WIRE	1	5	1	230	S30P4JP10221	26-1/2	35	L30P4EJ	14	10	P42B0010A2	25
1-1/2	6			1	230	S30P4JP15221	30-1/2	39	L30P4FJ	15-1/4	11	P42B0015A2	29		
3 WIRE	1		5	1	230	S30P4JP10231	26-1/2	35	L30P4EJ	14	10	P43B0010A2	23	SMC-CR1021	4
	1		5	3	230				L30P4EJ	15-1/2	10-1/4	P43B0010A3	23		
	1		5	3	460				L30P4EJ	15-1/2	10-1/4	P43B0010A4	23		
	1-1/2		6	1	230	S30P4JP15231	29	39	L30P4FJ	15-1/4	11	P43B0015A2	27	SMC-CR1521	7
	1-1/2		6	3	230				L30P4FJ	15-1/4	11	P43B0015A3	23		
	1-1/2		6	3	460				L30P4FJ	15-1/4	11	P43B0015A4	23		
	2		8	1	230				L30P4GJ	18-1/4	12	P43B0020A2	31	SMC-CR2021	7
	2		8	3	230				L30P4GJ	18-1/4	12	P43B0020A3	23		
	2		8	3	460				L30P4GJ	18-1/4	12	P43B0020A4	23		

†For all Pentek XE series three-phase motor options, see page 65.

\*Length and Weight are approximate.

\*\*For 10 GPM, 15 GPM, 20 GPM and 30 GPM discharge is 1-1/4" NPT.

NOTE: On 2 HP and larger pumps – Motor, Control Box or Magnetic Starter must be ordered separately.

# JP Series Signature 2000®

Composite

## OUTLINE DIMENSIONS

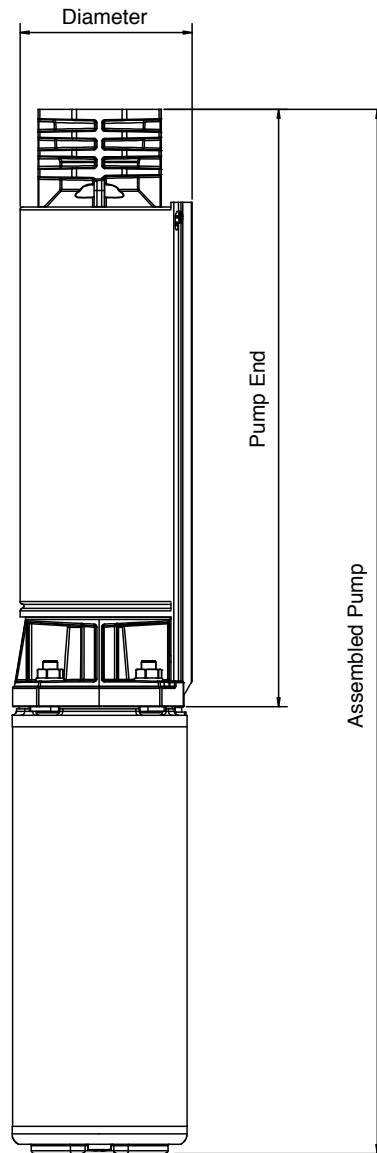

### DISCHARGE

10 GPM	1-1/4" NPT
15 GPM	1-1/4" NPT
20 GPM	1-1/4" NPT
30 GPM	1-1/4" NPT

For lengths, refer to Ordering Information tables.  
 Dimensions (in inches) are for estimating purposes only.

# JP Series Signature 2000®

Composite

## PUMP PERFORMANCE: 10 GPM

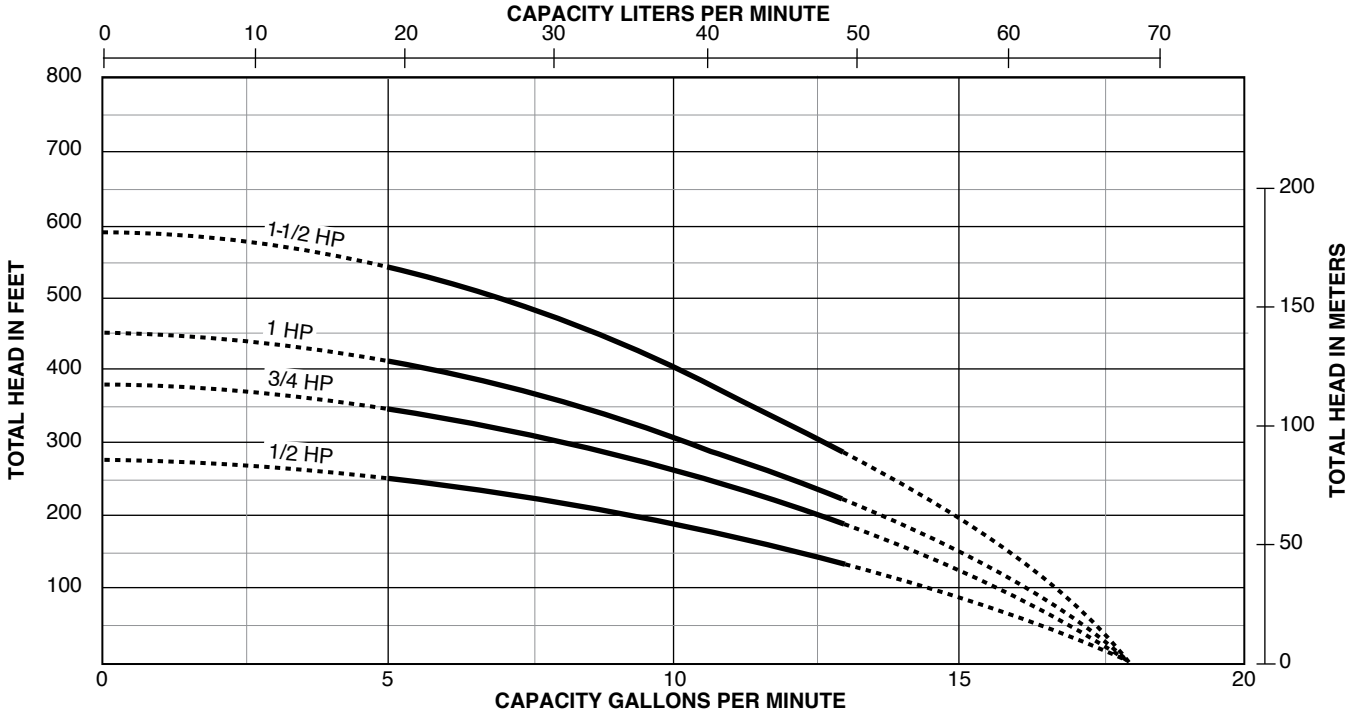

## PUMP PERFORMANCE: 15 GPM

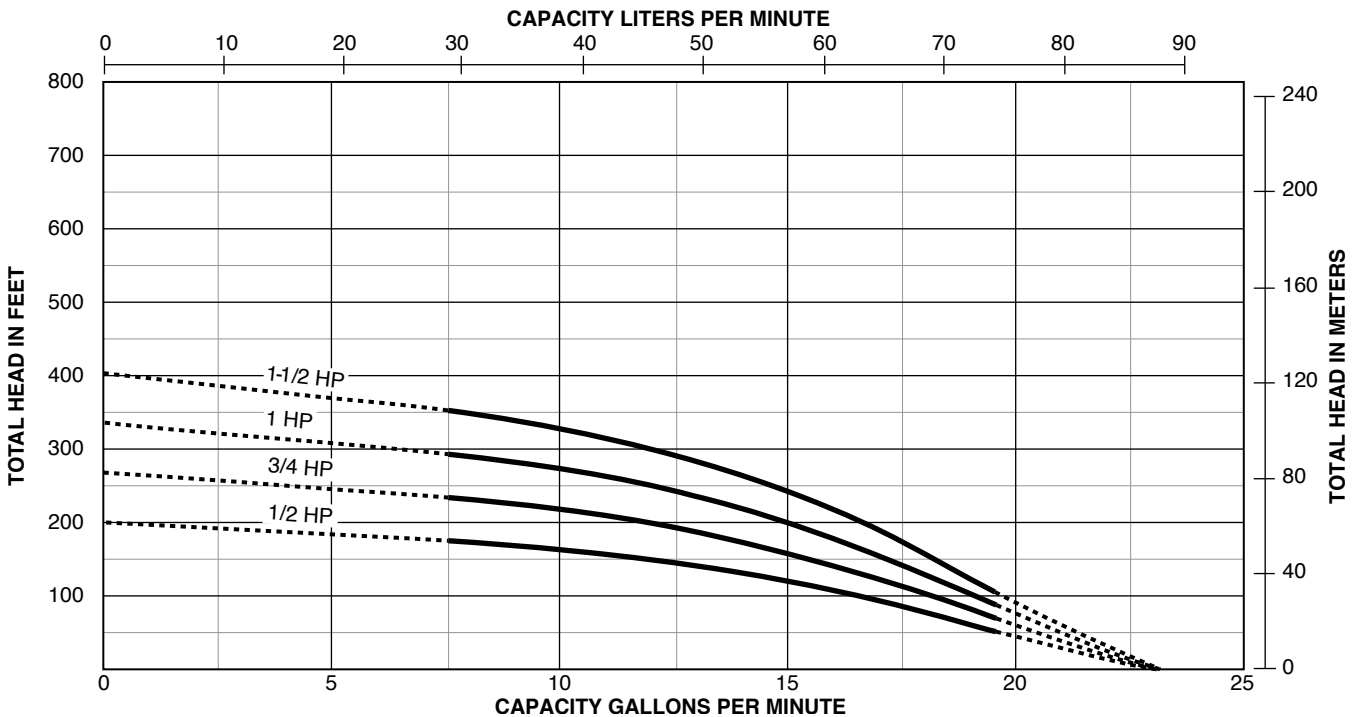

Tested and rated in accordance with Water Systems Council Standards.

NOTE: Pumps installed with a Pro-Source® tank require a 100 PSI relief valve. Pumps installed with a conventional tank require a 75 PSI relief valve. Relief valve must be capable of relieving entire flow of pump at relief pressure.

# JP Series Signature 2000®

Composite

## PUMP PERFORMANCE: 20 GPM

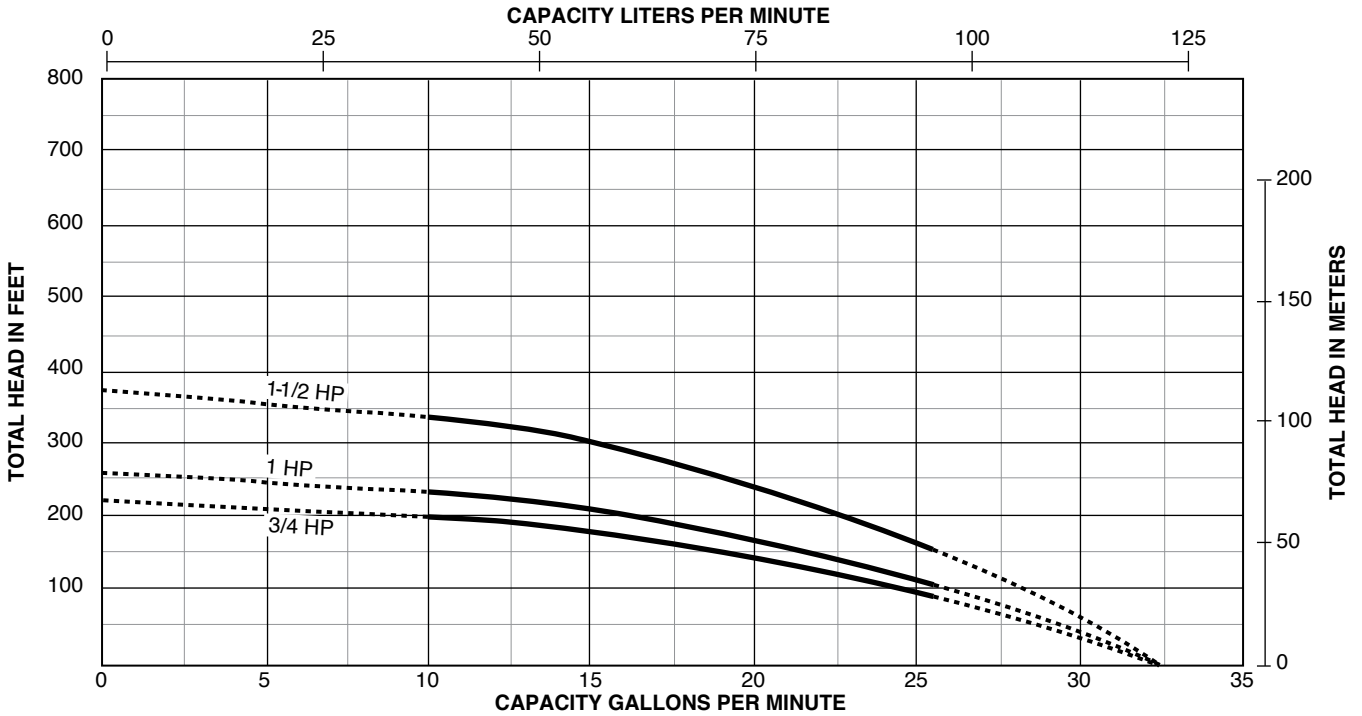

## PUMP PERFORMANCE: 30 GPM

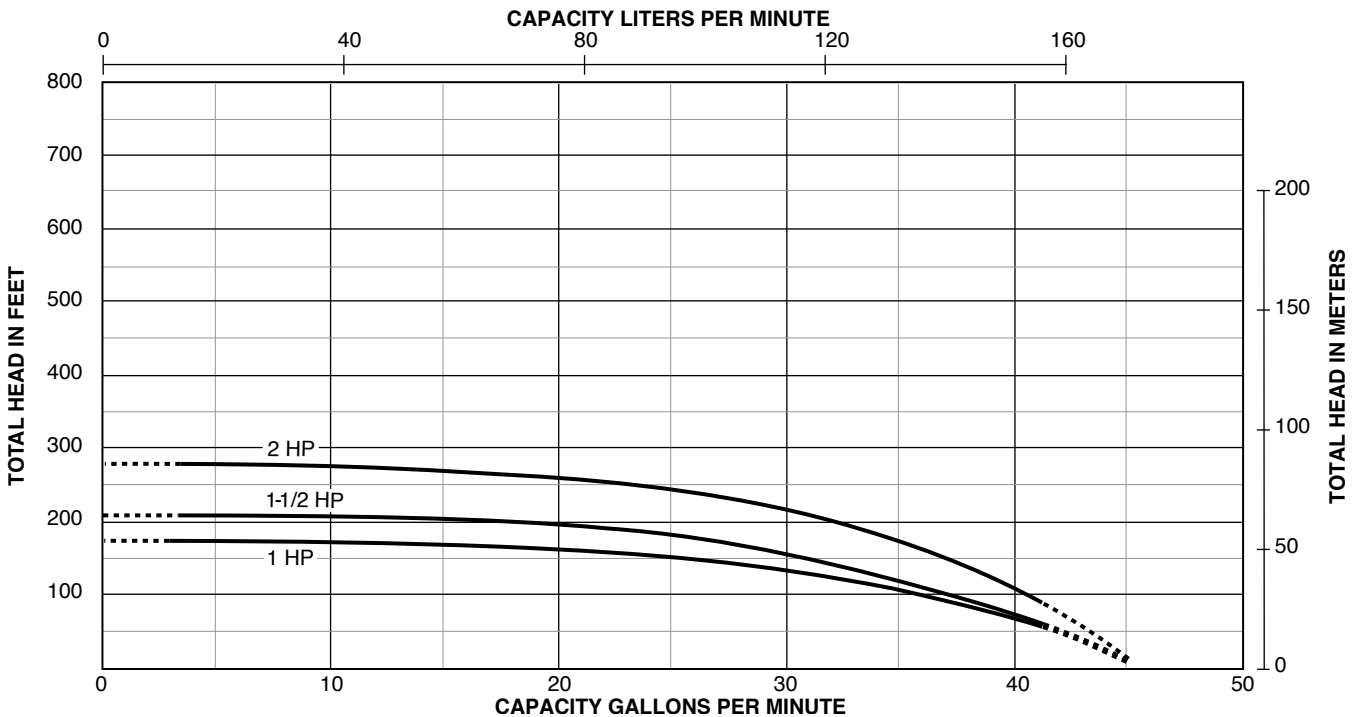

Tested and rated in accordance with Water Systems Council Standards.

NOTE: Pumps installed with a Pro-Source® tank require a 100 PSI relief valve. Pumps installed with a conventional tank require a 75 PSI relief valve. Relief valve must be capable of relieving entire flow of pump at relief pressure.

# JP Series Signature 2000®

Composite

10 GALLONS PER MINUTE		PUMP PERFORMANCE (Capacity in gallons per minute)																				SHUT-OFF HEAD									
HP	PSI	PUMPING DEPTH IN FEET																				FEET	PSI								
		0	20	40	60	80	100	120	140	160	180	200	220	240	260	280	300	320	340	360	380			400	450	500	550				
1/2	0	—	—	—	—	—	14.7	13.8	12.9	11.8	10.7	9.4	8.0	6.3	4.1											278	120				
	20	—	—	—	14.4	13.5	12.5	11.5	10.3	9.0	7.5	5.7	3.2																		
	30	—	—	14.3	13.4	12.4	11.3	10.1	8.8	7.3	5.4	2.7																			
	40	—	14.2	13.2	12.2	11.1	9.9	8.6	7.0	5.1	2.0																				
	50	14.0	13.1	12.1	11.0	9.7	8.4	6.8	4.7																						
	60	12.9	11.9	10.8	9.5	8.1	6.5	4.3																							
	70	11.7	10.6	9.3	7.9	6.2	3.9																								
	80	10.4	9.1	7.7	5.9	3.4																									
3/4	0	—	—	—	—	—	—	14.6	14.0	13.3	12.6	11.8	11.0	10.1	9.2	8.2	7.0	5.6	3.9							382	165				
	20	—	—	—	—	—	14.4	13.8	13.1	12.3	11.6	10.7	9.9	8.9	7.8	6.6	5.1	3.2													
	30	—	—	—	15.0	14.3	13.7	13.0	12.2	11.5	10.6	9.7	8.7	7.6	6.4	4.9	2.8														
	40	—	—	14.9	14.2	13.6	12.9	12.1	11.3	10.5	9.6	8.6	7.5	6.2	4.6	2.4															
	50	15.4	14.8	14.1	13.5	12.7	12.0	11.2	10.3	9.4	8.4	7.3	6.0	4.3																	
	60	14.7	14.0	13.3	12.6	11.9	11.1	10.2	9.3	8.2	7.1	5.7	4.0																		
	70	13.9	13.2	12.5	11.8	10.9	10.1	9.1	8.1	6.9	5.5	3.7																			
	80	13.1	12.4	11.6	10.8	9.9	9.0	7.9	6.7	5.3	3.4																				
1	0	—	—	—	—	—	—	—	14.8	14.2	13.7	13.1	12.5	11.8	11.1	10.4	9.6	8.8	7.9	6.9	5.7					452	195				
	20	—	—	—	—	—	—	14.6	14.1	13.5	12.9	12.3	11.6	10.9	10.2	9.4	8.5	7.6	6.6	5.3	3.8										
	30	—	—	—	—	—	14.5	14.0	13.4	12.8	12.2	11.5	10.8	10.1	9.3	8.4	7.5	6.4	5.1	3.5											
	40	—	—	—	15.0	14.5	13.9	13.3	12.7	12.1	11.4	10.7	9.9	9.1	8.3	7.3	6.2	4.9	3.2												
	50	—	—	14.9	14.4	13.8	13.2	12.6	12.0	11.3	10.6	9.8	9.0	8.1	7.1	6.0	4.7	2.9													
	60	—	14.8	14.3	13.7	13.1	12.5	11.9	11.2	10.5	9.7	8.9	8.0	7.0	5.8	4.4	2.6														
	70	14.7	14.2	13.6	13.0	12.4	11.8	11.1	10.4	9.6	8.7	7.8	6.8	5.6	4.2	2.2															
	80	14.1	13.5	12.9	12.3	11.7	11.0	10.2	9.5	8.6	7.7	6.6	5.4	3.9																	
1-1/2	0	—	—	—	—	—	—	—	—	—	15.0	14.6	14.1	13.7	13.3	12.8	12.3	11.8	11.3	10.8	10.2	8.6	6.8	4.3		590	256				
	20	—	—	—	—	—	—	—	—	14.9	14.4	14.0	13.6	13.1	12.6	12.2	11.7	11.1	10.6	10.0	9.4	8.8	6.9	4.5							
	30	—	—	—	—	—	—	—	14.8	14.4	13.9	13.5	13.0	12.6	12.1	11.6	11.1	10.5	9.9	9.3	8.7	8.0	5.9	2.9							
	40	—	—	—	—	—	—	14.7	14.3	13.9	13.4	13.0	12.5	12.0	11.5	11.0	10.4	9.8	9.2	8.6	7.9	7.1	4.7								
	50	—	—	—	—	—	14.7	14.2	13.8	13.4	12.9	12.4	11.9	11.4	10.9	10.3	9.7	9.1	8.5	7.7	7.0	6.1	3.2								
	60	—	—	—	15.0	14.6	14.2	13.7	13.3	12.8	12.4	11.9	11.3	10.8	10.2	9.6	9.0	8.3	7.6	6.8	6.0	4.9									
	70	—	—	14.9	14.5	14.1	13.7	13.2	12.8	12.3	11.8	11.3	10.7	10.1	9.5	8.9	8.2	7.5	6.7	5.8	4.8	3.5									
	80	—	14.9	14.5	14.0	13.6	13.2	12.7	12.2	11.7	11.2	10.6	10.1	9.5	8.8	8.1	7.4	6.6	5.7	4.6	3.3										

CAUTION: DO NOT use pump at flow rates indicated by the symbol '—'. To do so can cause premature failure of unit. Pump warranty void when failure occurs under these conditions. Tested and rated in accordance with Water Systems Council Standards.

NOTE: Pumps installed with a Pro-Source® tank require a 100 PSI relief valve. Pumps installed with a conventional tank require a 75 PSI relief valve. Relief valve must be capable of relieving entire flow of pump at relief pressure.

# JP Series Signature 2000®

Composite

15 GALLONS PER MINUTE		PUMP PERFORMANCE (Capacity in gallons per minute)																				SHUT-OFF HEAD					
HP	PSI	PUMPING DEPTH IN FEET																				FEET	PSI				
		0	20	40	60	80	100	120	140	160	180	200	220	240	260	280	300	320	340	360	380			400			
1/2	0	—	—	20.5	19.2	17.8	16.3	14.7	12.8	10.5	7.5												201	87			
	20	20.1	18.8	17.4	15.8	14.1	12.1	9.7	6.2																		
	30	18.6	17.1	15.6	13.8	11.8	9.2	5.5																			
	40	16.9	15.3	13.5	11.4	8.8	4.6																				
	50	15.1	13.2	11.0	8.3	3.4																					
	60	12.9	10.7	7.8																							
	70	10.3	7.2																								
	80	6.6																									
3/4	0	—	—	—	20.2	19.2	18.2	17.1	15.9	14.7	13.3	11.7	9.8	7.5	3.6								269	116			
	20	20.8	19.9	18.9	17.9	16.7	15.5	14.2	12.8	11.2	9.2	6.6															
	30	19.7	18.7	17.7	16.6	15.4	14.0	12.6	10.9	8.8	6.1																
	40	18.6	17.5	16.4	15.2	13.8	12.3	10.6	8.5	5.5																	
	50	17.3	16.2	15.0	13.6	12.1	10.3	8.1	4.8																		
	60	16.0	14.8	13.4	11.8	10.0	7.7	4.0																			
	70	14.5	13.1	11.5	9.7	7.3	3.0																				
	80	12.9	11.3	9.3	6.8																						
1	0	—	—	—	—	20.4	19.6	18.7	17.8	16.9	15.9	14.8	13.6	12.3	10.9	9.3	7.3	4.5					336	145			
	20	—	21.0	20.2	19.3	18.5	17.5	16.6	15.5	14.4	13.2	11.9	10.4	8.7	6.6	3.2											
	30	20.9	20.1	19.2	18.3	17.4	16.4	15.4	14.3	13.0	11.7	10.2	8.4	6.2	2.4												
	40	19.9	19.1	18.2	17.3	16.3	15.2	14.1	12.8	11.5	9.9	8.1	5.7														
	50	18.9	18.0	17.1	16.1	15.0	13.9	12.6	11.3	9.7	7.8	5.3															
	60	17.9	17.0	15.9	14.9	13.7	12.4	11.0	9.4	7.5	4.8																
	70	16.8	15.8	14.7	13.5	12.2	10.8	9.1	7.1	4.2																	
	80	15.6	14.5	13.3	12.0	10.6	8.8	6.7	3.6																		
1-1/2	0	—	—	—	—	20.5	19.9	19.2	18.5	17.8	17.1	16.3	15.5	14.7	13.7	12.8	11.7	10.5	9.1	7.5	5.3		403	174			
	20	—	20.9	20.3	19.7	19.0	18.3	17.6	16.9	16.1	15.3	14.4	13.4	12.4	11.3	10.1	8.7	6.9	4.3								
	30	20.8	20.2	19.6	18.9	18.2	17.5	16.7	16.0	15.1	14.2	13.3	12.3	11.2	9.9	8.4	6.6	3.8									
	40	20.1	19.5	18.8	18.1	17.4	16.6	15.8	15.0	14.1	13.1	12.1	11.0	9.7	8.2	6.2	3.0										
	50	19.4	18.7	18.0	17.3	16.5	15.7	14.9	14.0	13.0	11.9	10.8	9.5	7.9	5.9	1.8											
	60	18.6	17.9	17.1	16.4	15.6	14.7	13.8	12.8	11.8	10.6	9.2	7.6	5.5													
	70	17.8	17.0	16.3	15.4	14.6	13.7	12.7	11.6	10.4	9.0	7.3	5.1														
	80	16.9	16.1	15.3	14.4	13.5	12.5	11.4	10.2	8.8	7.0	4.6															

CAUTION: DO NOT use pump at flow rates indicated by the symbol '—'. To do so can cause premature failure of unit. Pump warranty void when failure occurs under these conditions.

Tested and rated in accordance with Water Systems Council Standards.

NOTE: Pumps installed with a Pro-Source® tank require a 100 PSI relief valve. Pumps installed with a conventional tank require a 75 PSI relief valve. Relief valve must be capable of relieving entire flow of pump at relief pressure.

# JP Series Signature 2000®

Composite

20 GALLONS PER MINUTE		PUMP PERFORMANCE (Capacity in gallons per minute)																				SHUT-OFF HEAD					
HP	PSI	PUMPING DEPTH IN FEET																				FEET	PSI				
		0	20	40	60	80	100	120	140	160	180	200	220	240	260	280	300	320	340	360	380			400			
3/4	0	—	—	—	—	26.9	25.0	23.0	20.7	18.1	15.1	11.3	4.9										225	97			
	20	—	—	26.3	24.4	22.3	19.9	17.3	14.1	9.8																	
	30	27.9	26.1	24.1	21.9	19.6	16.8	13.5	9.0																		
	40	25.8	23.8	21.6	19.2	16.4	12.9	8.0																			
	50	23.4	21.2	18.8	15.9	12.3	7.0																				
	60	20.9	18.3	15.4	11.6	5.7																					
	70	17.9	14.9	10.9	3.8																						
	80	14.3	10.2																								
1	0	—	—	—	—	27.9	26.4	24.7	23.0	21.0	18.9	16.5	13.6	10.0	2.8								262	114			
	20	—	—	27.5	25.9	24.2	22.4	20.4	18.2	15.7	12.6	8.5															
	30	—	27.2	25.6	23.9	22.1	20.1	17.8	15.2	12.1	7.6																
	40	27.0	25.4	23.7	21.8	19.7	17.5	14.8	11.5	6.6																	
	50	25.1	23.4	21.5	19.4	17.1	14.3	10.9	5.5																		
	60	23.1	21.2	19.1	16.7	13.9	10.3	3.9																			
	70	20.9	18.7	16.3	13.4	9.6																					
	80	18.4	15.9	12.9	8.8																						
1-1/2	0	—	—	—	—	—	—	27.9	26.8	25.6	24.4	23.1	21.7	20.2	18.6	16.9	15.0	12.7	10.0	6.1			375	162			
	20	—	—	—	—	27.5	26.4	25.2	24.0	22.6	21.3	19.8	18.1	16.3	14.3	12.0	9.0	4.1									
	30	—	—	—	27.4	26.2	25.0	23.8	22.4	21.0	19.5	17.9	16.0	14.0	11.6	8.4	2.6										
	40	—	—	27.2	26.0	24.8	23.6	22.2	20.8	19.3	17.6	15.7	13.6	11.1	7.8												
	50	—	27.0	25.8	24.6	23.4	22.0	20.6	19.0	17.3	15.4	13.3	10.7	7.2													
	60	26.8	25.7	24.4	23.2	21.8	20.3	18.8	17.0	15.1	12.9	10.2	6.5														
	70	25.5	24.2	23.0	21.6	20.1	18.5	16.8	14.8	12.5	9.7	5.6															
	80	24.1	22.7	21.4	19.9	18.2	16.5	14.5	12.2	9.2	4.7																

CAUTION: DO NOT use pump at flow rates indicated by the symbol '—'. To do so can cause premature failure of unit. Pump warranty void when failure occurs under these conditions. Tested and rated in accordance with Water Systems Council Standards.

NOTE: Pumps installed with a Pro-Source® tank require a 100 PSI relief valve. Pumps installed with a conventional tank require a 75 PSI relief valve. Relief valve must be capable of relieving entire flow of pump at relief pressure.

# JP Series Signature 2000®

Composite

30 GALLONS PER MINUTE																PUMP PERFORMANCE (Capacity in gallons per minute)	
HP	PSI	PUMPING DEPTH IN FEET														SHUT-OFF HEAD	
		20	40	60	80	100	125	150	175	200	250	300	350	400	450	FEET	PSI
1	0	—	—	40.9	39.1	36.8	32.5	26.0	8.0							175	76
	20	40.4	38.8	36.0	32.4	27.7	13.3										
	30	38.0	35.3	31.7	26.3	14.3											
	40	35.0	31.4	25.9	12.1												
	50	30.2	24.0	3.0													
	60	21.9															
1-1/2	0	—	—	41.9	39.9	37.5	34.1	30.9	26.9	17.0					210	91	
	20	41.2	39.1	36.5	34.0	31.5	27.8	21.5									
	30	38.9	36.1	33.8	31.0	27.9	21.8										
	40	36.0	33.5	30.8	27.7	20.2											
	50	32.9	30.1	26.8	21.5												
	60	29.5	25.9	18.1													
2	0	—	—	—	41.8	40.5	38.8	36.8	34.7	31.6	23.7				280	121	
	20	—	41.3	40.1	38.7	37.1	34.9	32.1	29.0	24.8							
	30	41.2	40.0	38.5	37.0	35.0	32.2	29.1	24.9	15.2							
	40	39.9	38.3	36.6	34.8	32.7	29.8	25.1	16.1								
	50	38.0	36.3	34.5	32.1	30.0	25.3	17.5									
	60	36.0	34.0	31.9	29.1	26.0	18.0										

CAUTION: DO NOT use pump at flow rates indicated by the symbol '—'. To do so can cause premature failure of unit. Pump warranty void when failure occurs under these conditions. Tested and rated in accordance with Water Systems Council Standards.

NOTE: Pumps installed with a Pro-Source® tank require a 100 PSI relief valve. Pumps installed with a conventional tank require a 75 PSI relief valve. Relief valve must be capable of relieving entire flow of pump at relief pressure.

# K Series

Composite



POWERED BY  
**PENTEK**<sup>®</sup>



The K Series 4" Submersible Pumps in 5, 7, 10 and 20 GPM models offer dependable performance and value.

K Series pumps will handle dry run conditions.

Proven "Floating Impeller" staging system is designed with a corrosive resistant stainless steel wear surface that greatly reduces problems with abrasives and sand lock-up.

Powered by water-filled submersible motors.

## APPLICATIONS

**Water systems...** for residential, commercial, irrigation and farm use.

## SPECIFICATIONS

**Shell:** Stainless steel

**Discharge:** Fiberglass-reinforced thermoplastic

**Discharge Bearing:** Nylatron<sup>®</sup>

**Impellers:** Acetal

**Diffusers:** Polycarbonate

**Suction Caps:** Polycarbonate with stainless steel insert

**Thrust Pads:** Proprietary spec.

**Shaft and Coupling:** Stainless steel 300 grade

**Motor Bracket/Intake Screen** Fiberglass-reinforced thermoplastic

**Check Valve:** Durable internal check valve

**Cable Guard:** Rigid PVC

## FEATURES

**Proven "Floating Impeller" Staging System:** Incorporates 1st-in-class performance, sand handling and thrust management staging system with the industry exclusive "dry-run" design element. Reinforced engineered composites and stainless steel, offering high resistance to corrosion and abrasion.

**Discharge:** Tested-tough, fiberglass-reinforced thermoplastic, with proven internal check valve. Large wrench flats and rope hole.

**Shell:** 300-grade stainless steel pump shell offers high corrosion resistance.

**Shaft:** Hexagonal 3/8", 300-grade stainless steel pump shaft; offers generous impeller drive surfaces.

**Shaft Bearing:** Exclusive self-lubricating Nylatron<sup>®</sup> bearing resists wear surface from sand..

**Motor Bracket:** Tested-tough, fiberglass-reinforced thermoplastic; incorporates an integral suction screen.

**Cable Guard:** Corrosion resistant rigid PVC with 300-grade stainless steel fasteners.

# K Series

Composite

## ORDERING INFORMATION

GPM	Motor Type	HP	Stages	Phase	Volt	Catalog Number	Weight Pounds*
5 GPM	2 wire	1/2	12	1	115V	S5K05121	27.2
		1/2	12	1	230V	S5K05221	27.2
		3/4	17	1	230V	S5K07221	32.7
	3 wire	1	21	1	230V	S5K10221	35.5
		1/2	12	1	230V	S5K05231	26.1
		3/4	17	1	230V	S5K07231	31.4
	1	21	1	230V	S5K10231	34.1	
7 GPM	2 wire	1/2	10	1	115V	S7K05121	27.2
		1/2	10	1	230V	S7K05221	27.2
		3/4	13	1	230V	S7K07221	32.7
		1	17	1	230V	S7K10221	35.5
	3 wire	1/2	10	1	230V	S7K05231	26.1
		3/4	13	1	230V	S7K07231	31.4
	1	17	1	230V	S7K10231	34.1	
10 GPM	2 wire	1/2	7	1	115V	S10K05121	27.2
		1/2	7	1	230V	S10K05221	27.2
		3/4	9	1	230V	S10K07221	32.7
		1	12	1	230V	S10K10221	35.5
		1 1/2	16	1	230V	S10K15221	42.9
	3 wire	1/2	7	1	230V	S10K05231	26.1
		3/4	9	1	230V	S10K07231	31.4
		1	12	1	230V	S10K10231	34.1
	1 1/2	16	1	230V	S10K15231	41.4	
20 GPM	2 wire	1	7	1	230V	S20K10221	35.5
		1 1/2	9	1	230V	S20K15221	42.9
	3 wire	1	7	1	230V	S20K10231	34.1
		1 1/2	9	1	230V	S20K15231	41.4

\*Weight is approximate

# K Series

Composite

**PUMP PERFORMANCE: 5 GPM**

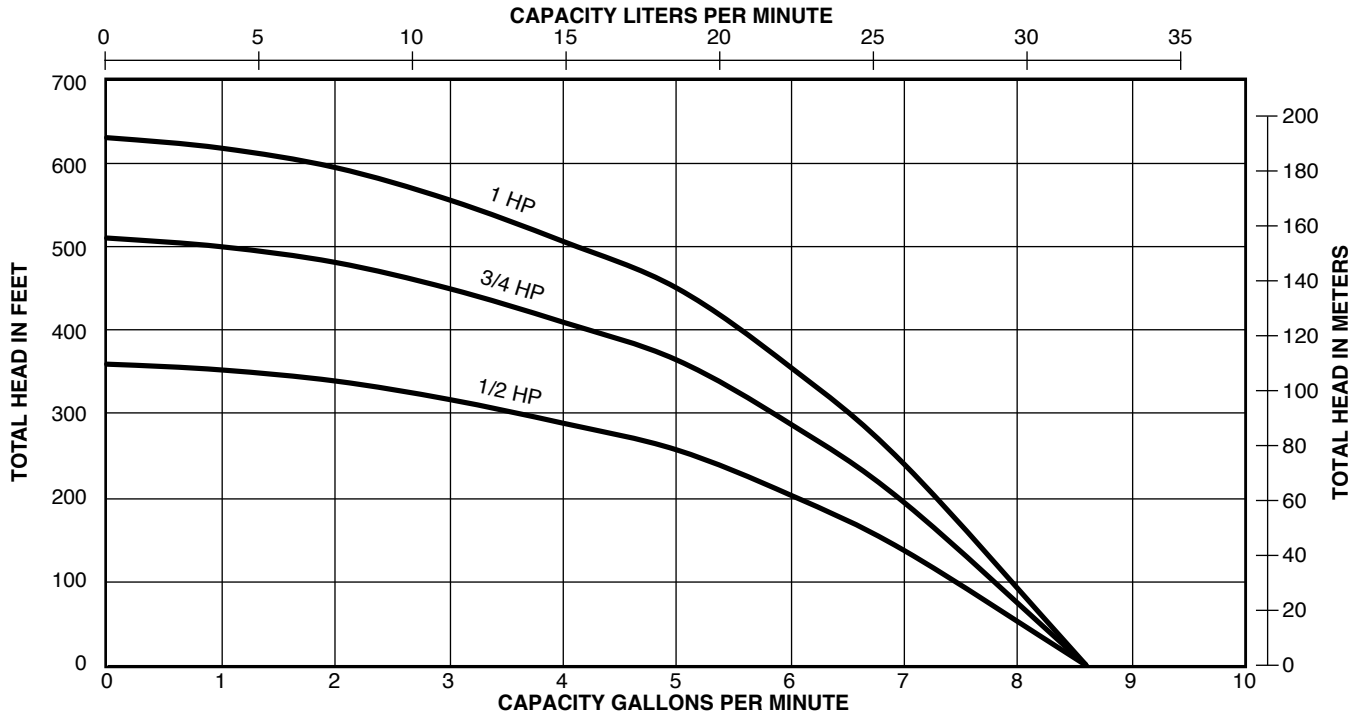

**CAPACITY IN GALLONS PER MINUTE**

	PSI	Pumping Depth in Feet																
		0	20	40	60	80	100	125	150	175	200	250	300	350	400	500	600	
<b>21 Stages, 1HP</b>	0	-	-	-	-	-	-	-	-	7.5	7.3	7.1	6.9	6.4	6.0	5.4	4.2	2.2
	20	-	-	-	-	-	-	-	7.5	7.3	7.1	6.9	6.5	6.0	5.5	4.9	3.4	
	30	-	-	-	-	-	7.5	7.3	7.1	6.9	6.7	6.2	5.8	5.2	4.6	3.0		
	40	-	-	-	-	7.5	7.3	7.1	6.9	6.7	6.5	6.0	5.5	5.0	4.3	2.4		
	50	-	-	-	7.4	7.3	7.1	6.9	6.7	6.5	6.3	5.8	5.3	4.7	4.0	1.5		
	60	-	-	7.4	7.3	7.1	6.9	6.7	6.5	6.3	6.1	5.6	5.0	4.4	3.6			
	70	-	7.4	7.2	7.1	6.9	6.8	6.5	6.3	6.1	5.8	5.3	4.7	4.0	3.1			
	80	7.4	7.2	7.1	6.9	6.7	6.6	6.3	6.1	5.9	5.6	5.0	4.4	3.6	2.6			
<b>17 Stages, 0.75HP</b>	0	-	-	-	-	-	-	-	7.4	7.1	6.9	6.3	5.7	5.1	4.3	1.3		
	20	-	-	-	-	-	7.4	7.2	6.9	6.7	6.4	5.8	5.1	4.3	3.3			
	30	-	-	-	-	7.4	7.2	6.9	6.7	6.4	6.1	5.5	4.8	3.9	2.7			
	40	-	-	7.5	7.4	7.2	7.0	6.7	6.4	6.1	5.8	5.2	4.4	3.4	1.8			
	50	-	7.5	7.3	7.1	6.9	6.7	6.4	6.2	5.9	5.5	4.8	4.0	2.8				
	60	7.5	7.3	7.1	6.9	6.7	6.5	6.2	5.9	5.6	5.2	4.5	3.5	2.0				
	70	7.3	7.1	6.9	6.7	6.4	6.2	5.9	5.6	5.3	4.9	4.1	3.0					
	80	7.0	6.8	6.6	6.4	6.2	5.9	5.6	5.3	4.9	4.5	3.6	2.2					
<b>12 Stages, 0.5HP</b>	0	-	-	-	-	-	7.5	7.1	6.7	6.4	6.0	5.0	3.8	1.6				
	20	-	-	-	7.4	7.1	6.8	6.4	6.0	5.6	5.1	3.9	1.9					
	30	-	-	7.3	7.1	6.8	6.5	6.0	5.6	5.1	4.6	3.2						
	40	-	7.3	7.0	6.7	6.4	6.1	5.6	5.2	4.6	4.0	2.2						
	50	7.2	7.0	6.7	6.4	6.0	5.7	5.2	4.7	4.1	3.3							
	60	6.9	6.6	6.3	6.0	5.6	5.2	4.7	4.1	3.4	2.4							
	70	6.6	6.3	5.9	5.6	5.2	4.8	4.2	3.5	2.5								
	80	6.2	5.9	5.5	5.1	4.7	4.2	3.5	2.6									

# K Series

Composite

**PUMP PERFORMANCE: 7 GPM**

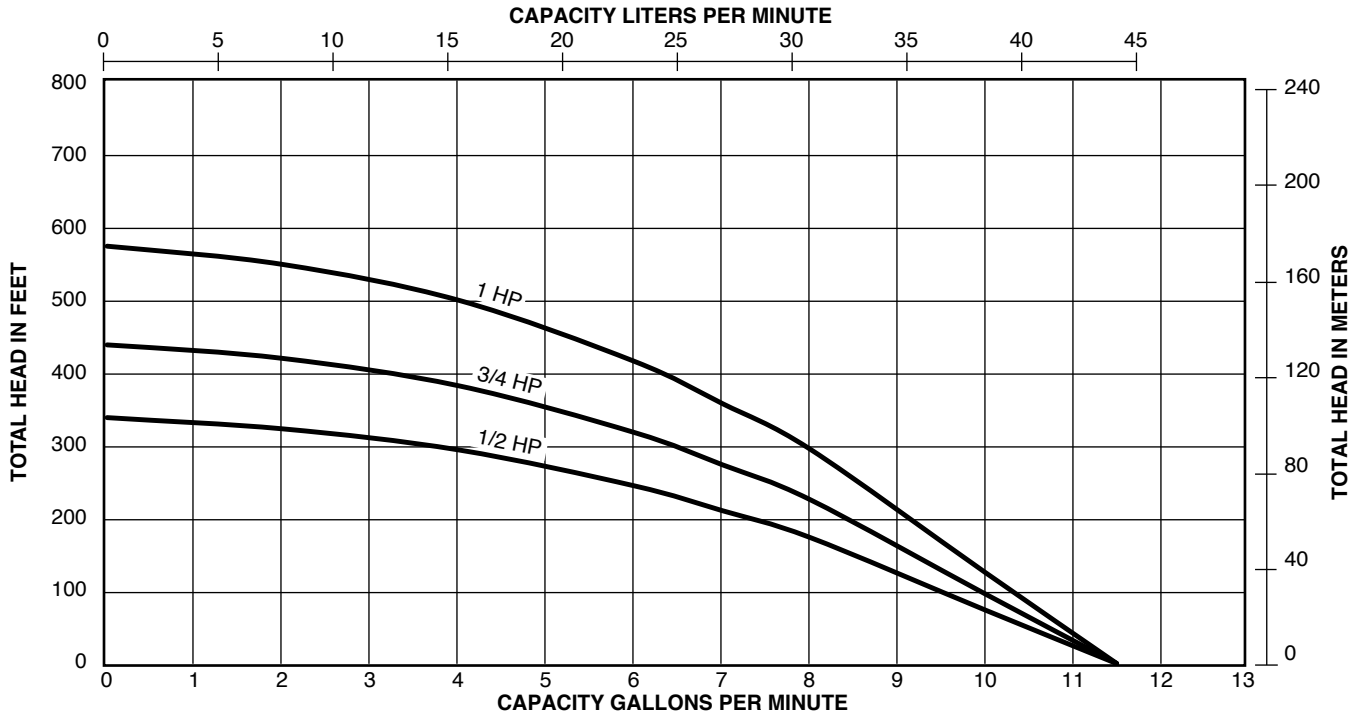

**CAPACITY IN GALLONS PER MINUTE**

	PSI	Pumping Depth in Feet															
		0	20	40	60	80	100	125	150	175	200	250	300	350	400	500	600
<b>17 Stages, 1HP</b>	0	-	-	11.0	10.8	10.6	10.4	10.1	9.8	9.5	9.2	8.6	7.9	7.1	6.2	4.0	
	20	11.0	10.8	10.6	10.3	10.1	9.9	9.6	9.3	9.0	8.6	7.9	7.2	6.3	5.3	2.4	
	30	10.7	10.5	10.3	10.1	9.8	9.6	9.3	9.0	8.6	8.3	7.6	6.8	5.9	4.8		
	40	10.5	10.3	10.0	9.8	9.6	9.3	9.0	8.7	8.3	8.0	7.2	6.4	5.4	4.2		
	50	10.2	10.0	9.8	9.5	9.3	9.0	8.7	8.4	8.0	7.6	6.8	5.9	4.9	3.5		
	60	10.0	9.7	9.5	9.2	9.0	8.7	8.4	8.0	7.7	7.3	6.4	5.5	4.3	2.7		
	70	9.7	9.4	9.2	8.9	8.7	8.4	8.1	7.7	7.3	6.9	6.0	5.0	3.7			
	80	9.4	9.2	8.9	8.6	8.4	8.1	7.7	7.3	6.9	6.5	5.6	4.4	2.8			
<b>13 Stages, 0.75HP</b>	0	-	-	10.9	10.6	10.3	10.1	9.7	9.3	8.9	8.4	7.5	6.4	5.1	3.3		
	20	10.8	10.5	10.3	10.0	9.6	9.3	8.9	8.5	8.0	7.5	6.5	5.2	3.4			
	30	10.5	10.2	9.9	9.6	9.3	8.9	8.5	8.1	7.6	7.1	5.9	4.5	2.3			
	40	10.2	9.9	9.6	9.2	8.9	8.6	8.1	7.6	7.1	6.6	5.3	3.6				
	50	9.8	9.5	9.2	8.8	8.5	8.1	7.7	7.1	6.6	6.0	4.6	2.5				
	60	9.5	9.1	8.8	8.4	8.1	7.7	7.2	6.6	6.0	5.4	3.8					
	70	9.1	8.7	8.4	8.0	7.6	7.2	6.7	6.1	5.4	4.7	2.7					
	80	8.7	8.3	8.0	7.6	7.2	6.7	6.1	5.5	4.8	3.9						
<b>10 Stages, 0.5HP</b>	0	-	-	10.8	10.4	10.0	9.6	9.1	8.5	7.9	7.3	5.8	3.7				
	20	10.6	10.3	9.9	9.5	9.0	8.6	8.0	7.4	6.7	5.9	3.9					
	30	10.2	9.8	9.4	9.0	8.5	8.0	7.4	6.7	5.9	5.1	2.5					
	40	9.7	9.3	8.9	8.4	8.0	7.5	6.8	6.0	5.1	4.1						
	50	9.3	8.8	8.4	7.9	7.4	6.8	6.1	5.2	4.2	2.8						
	60	8.8	8.3	7.8	7.3	6.7	6.1	5.3	4.3	2.9							
	70	8.2	7.7	7.2	6.6	6.0	5.3	4.3	3.0								
	80	7.7	7.1	6.6	5.9	5.2	4.4	3.2									

# K Series

Composite

**PUMP PERFORMANCE: 10 GPM**

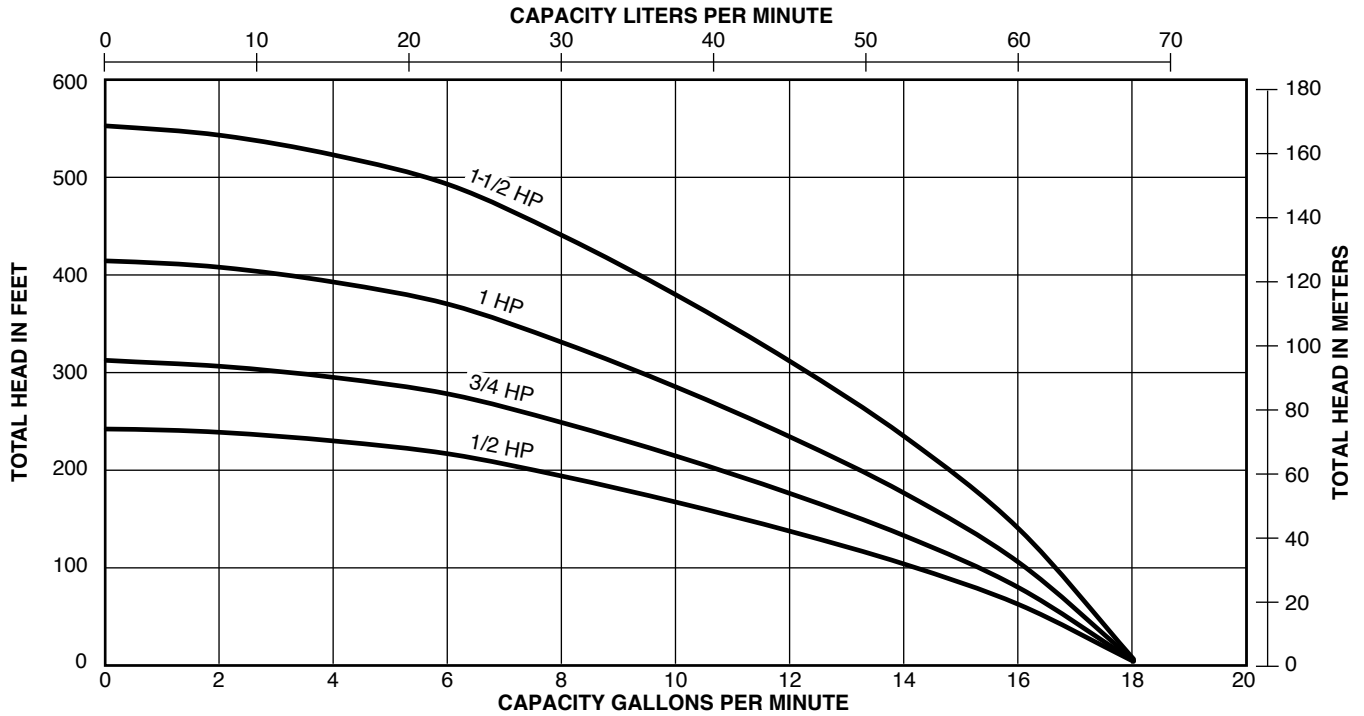

**CAPACITY IN GALLONS PER MINUTE**

	PSI	Pumping Depth in Feet															
		0	20	40	60	80	100	125	150	175	200	250	300	350	400	500	
<b>16 Stages, 1.5HP</b>	0	-	-	-	-	-	-	-	-	-	14.6	13.5	12.3	11.0	9.5	5.6	
	20	-	-	-	-	-	-	-	-	14.6	14.1	13.6	12.4	11.1	9.7	8.0	2.0
	30	-	-	-	-	-	-	-	14.7	14.1	13.6	13.0	11.8	10.5	8.9	7.0	
	40	-	-	-	-	-	14.7	14.2	13.6	13.1	12.5	11.2	9.8	8.1	6.0		
	50	-	-	-	-	14.6	14.2	13.7	13.1	12.5	11.9	10.6	9.0	7.2	4.7		
	60	-	-	15.0	14.6	14.2	13.7	13.2	12.6	12.0	11.3	9.9	8.2	6.2	2.9		
	70	-	14.9	14.5	14.1	13.7	13.2	12.6	12.0	11.4	10.7	9.2	7.4	4.9			
	80	14.9	14.5	14.0	13.6	13.1	12.7	12.1	11.4	10.7	10.0	8.4	6.3	3.2			
<b>12 Stages, 1HP</b>	0	-	-	-	-	-	-	-	14.6	13.8	13.1	11.5	9.5	7.1	3.4		
	20	-	-	-	-	-	14.7	14.0	13.2	12.4	11.6	9.7	7.4	3.8			
	30	-	-	-	-	14.6	14.0	13.3	12.5	11.7	10.8	8.7	6.0				
	40	-	-	15.0	14.5	13.9	13.3	12.6	11.7	10.8	9.9	7.6	4.2				
	50	-	15.0	14.4	13.8	13.2	12.6	11.8	10.9	9.9	8.9	6.2					
	60	14.9	14.3	13.7	13.1	12.5	11.9	11.0	10.0	9.0	7.8	4.5					
	70	14.2	13.6	13.0	12.4	11.7	11.0	10.1	9.0	7.9	6.5						
	80	13.6	12.9	12.3	11.6	10.9	10.2	9.1	7.9	6.6	4.8						
<b>9 Stages, 0.75HP</b>	0	-	-	-	-	-	15.0	14.1	13.1	12.0	10.9	8.0	3.4				
	20	-	-	-	14.8	14.0	13.3	12.2	11.0	9.8	8.3	3.9					
	30	-	-	14.7	13.9	13.1	12.3	11.1	9.9	8.4	6.6						
	40	-	14.6	13.8	13.0	12.1	11.2	10.0	8.5	6.8	4.4						
	50	14.4	13.7	12.9	12.0	11.1	10.1	8.6	6.9	4.6							
	60	13.6	12.7	11.9	10.9	9.9	8.7	7.1	4.8								
	70	12.6	11.7	10.8	9.7	8.6	7.2	5.0									
	80	11.6	10.6	9.6	8.4	7.0	5.2										
<b>7 Stages, 0.5HP</b>	0	-	-	-	-	14.9	13.9	12.7	11.2	9.5	7.5						
	20	-	-	14.6	13.6	12.6	11.4	9.8	7.9	5.3							
	30	-	14.5	13.5	12.4	11.2	9.9	8.0	5.5								
	40	14.3	13.3	12.2	11.1	9.7	8.2	5.7									
	50	13.2	12.1	10.9	9.5	7.9	6.0										
	60	11.9	10.7	9.3	7.7	5.6	2.1										
	70	10.5	9.0	7.4	5.2												
	80	8.8	7.1	4.8													

# K Series

Composite

**PUMP PERFORMANCE: 20 GPM**

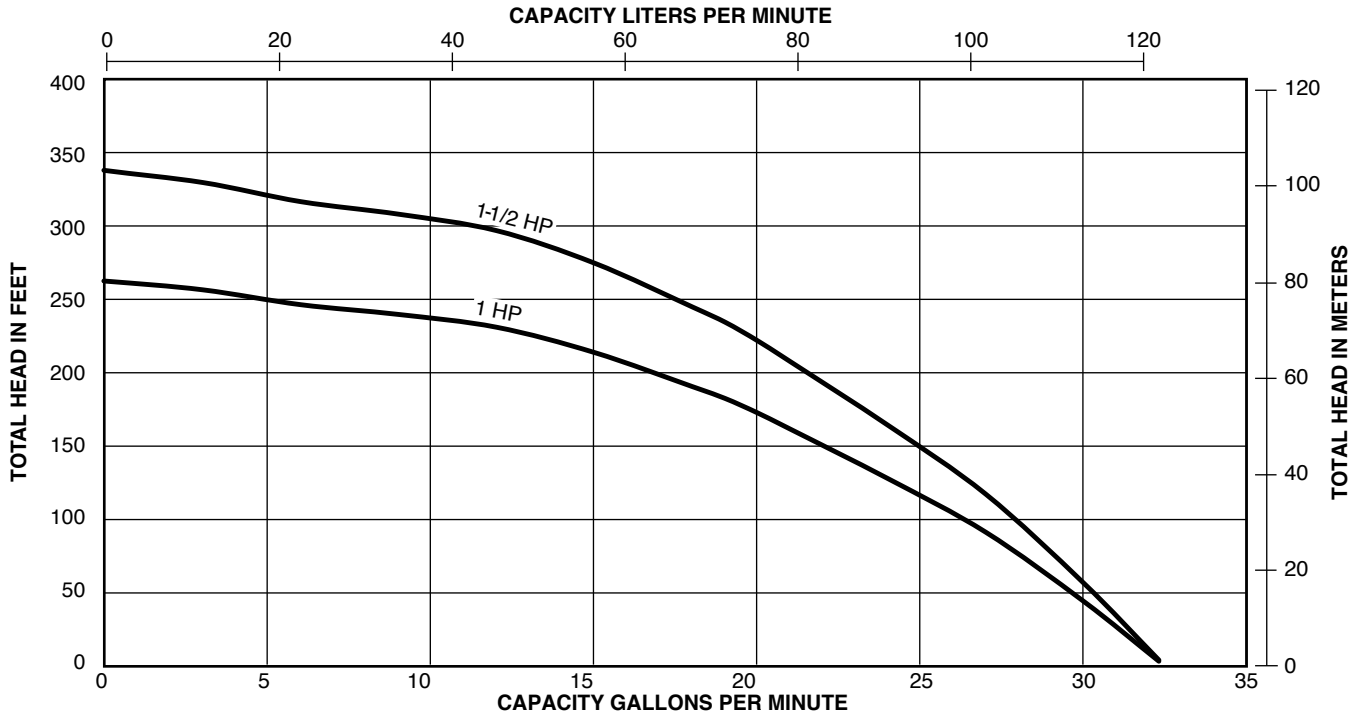

**CAPACITY IN GALLONS PER MINUTE**

	PSI	Pumping Depth in Feet											
		0	20	40	60	80	100	125	150	175	200	250	300
<b>9 Stages, 1.5HP</b>	0	-	-	-	-	-	27.7	26.3	24.8	23.2	21.4	17.4	11.6
	20	-	-	-	27.4	26.2	25.0	23.4	21.7	19.8	17.7	12.2	
	30	-	-	27.2	26.0	24.8	23.6	21.9	20.0	17.9	15.4	8.0	
	40	-	27.0	25.9	24.6	23.4	22.0	20.1	18.0	15.6	12.7		
	50	26.8	25.7	24.5	23.2	21.8	20.3	18.2	15.8	12.9	8.9		
	60	25.5	24.3	22.9	21.5	20.0	18.4	16.0	13.2	9.2			
	70	24.1	22.7	21.3	19.8	18.1	16.2	13.4	9.6				
	80	22.5	21.1	19.5	17.8	15.9	13.7	10.0					
<b>7 Stages, 1HP</b>	0	-	-	-	-	27.6	26.1	24.1	22.0	19.5	16.7	7.4	
	20	-	-	27.1	25.6	24.0	22.3	19.9	17.1	13.7	8.6		
	30	-	26.9	25.4	23.8	22.0	20.1	17.4	14.0	9.1			
	40	26.7	25.1	23.5	21.7	19.8	17.6	14.3	9.6				
	50	24.9	23.2	21.4	19.5	17.2	14.6	10.1					
	60	23.0	21.2	19.1	16.8	14.1	10.5						
	70	20.9	18.8	16.5	13.6	9.8							
	80	18.5	16.1	13.1	9.0								

# K Series

Composite

## OUTLINE DIMENSIONS

DISCHARGE		
GPM	NPT	"D"
5	1-1/4"	3-3/4"
7	1-1/4"	3-3/4"
10	1-1/4"	3-7/8"
20	1-1/4"	3-7/8"

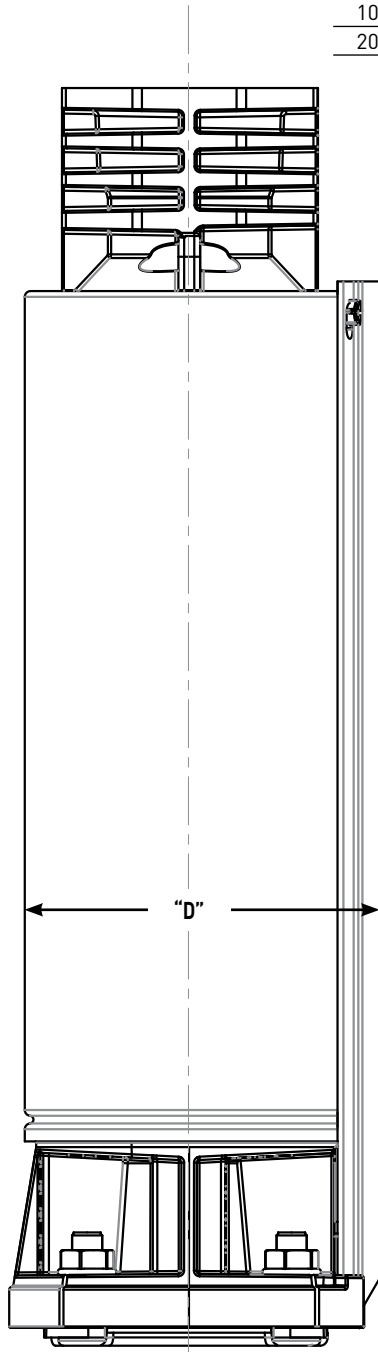

For lengths, refer to Ordering Information tables.  
Dimensions (in inches) are for estimating purposes only.

# KS Series

Stainless Steel



POWERED BY  
**PENTEK**<sup>®</sup>



**KS Series 4" Submersible Pumps in 10 and 20 GPM models offer dependable performance and value.**

**KS Series pumps will handle dry run conditions.**

**Proven "Floating Impeller" staging system is designed with a corrosive resistant stainless steel wear surface that greatly reduces problems with abrasives and sand lock-up.**

**Powered by water-filled submersible motors.**

## APPLICATIONS

**Water systems...** for residential, commercial, irrigation and farm use.

## SPECIFICATIONS

**Shell:** Stainless steel

**Discharge:** Stainless steel

**Discharge Bearing:** Nylatron<sup>®</sup>

**Impellers:** Acetal

**Diffusers:** Polycarbonate

**Suction Cap:** Polycarbonate with stainless steel wear ring

**Thrust Pads:** Proprietary spec.

**Shaft and Coupling:** Stainless steel  
300 grade

**Intake Screen:** Polypropylene

**Motor Bracket:** Stainless steel

**Check Valve:** Durable internal check valve

**Cable Guard:** Rigid PVC

## FEATURES

**Proven "Floating Impeller" Staging System:** Incorporates high performance, sand handling and thrust management staging system with "dry-run" design. Reinforced engineered composites and stainless steel, offering high resistance to corrosion and abrasion.

**Discharge:** Corrosion-resistant, heavy-duty 300-grade stainless steel with proven internal check valve. Large wrench flats and rope hole.

**Shell:** 300-grade stainless steel pump shell offers high corrosion resistance.

**Shaft:** Hexagonal 3/8", 300-grade stainless steel pump shaft; offers generous impeller drive surfaces.

**Shaft Bearing:** Exclusive self-lubricating Nylatron<sup>®</sup> bearing resists wear surface from sand.

**Motor Bracket:** Corrosion-resistant, heavy-duty 300-grade stainless steel.

**Cable Guard:** Corrosion resistant rigid PVC with 300-grade stainless steel fasteners.

**Pentek<sup>®</sup> Motor:** NEMA standard all stainless steel construction water-filled motors.

# KS Series

Stainless Steel

## ORDERING INFORMATION

GPM	Motor Type	HP	Phase	Volt	Assembled Pump Catalog Number	Weight Pounds*
10 GPM	2 wire	1/2	1	115V	S10KS05121	35.2
		1/2	1	230V	S10KS05221	35.2
		3/4	1	230V	S10KS07221	42.7
		1	1	230V	S10KS10221	46.5
		1 1/2	1	230V	S10KS15221	56.9
	3 wire	1/2	1	115V	S10KS05131	34.9
		1/2	1	230V	S10KS05231	34.1
		3/4	1	230V	S10KS07231	41.4
		1	1	230V	S10KS10231	45.1
		1 1/2	1	230V	S10KS15231	55.4
20 GPM	2 wire	1	1	230V	S20KS10221	46.5
		1 1/2	1	230V	S20KS15221	56.9
	3 wire	1	1	230V	S20KS10231	45.1
		1 1/2	1	230V	S20KS15231	55.4

\*Weight is approximate

# KS Series

Stainless Steel

## PUMP PERFORMANCE: 10 GPM

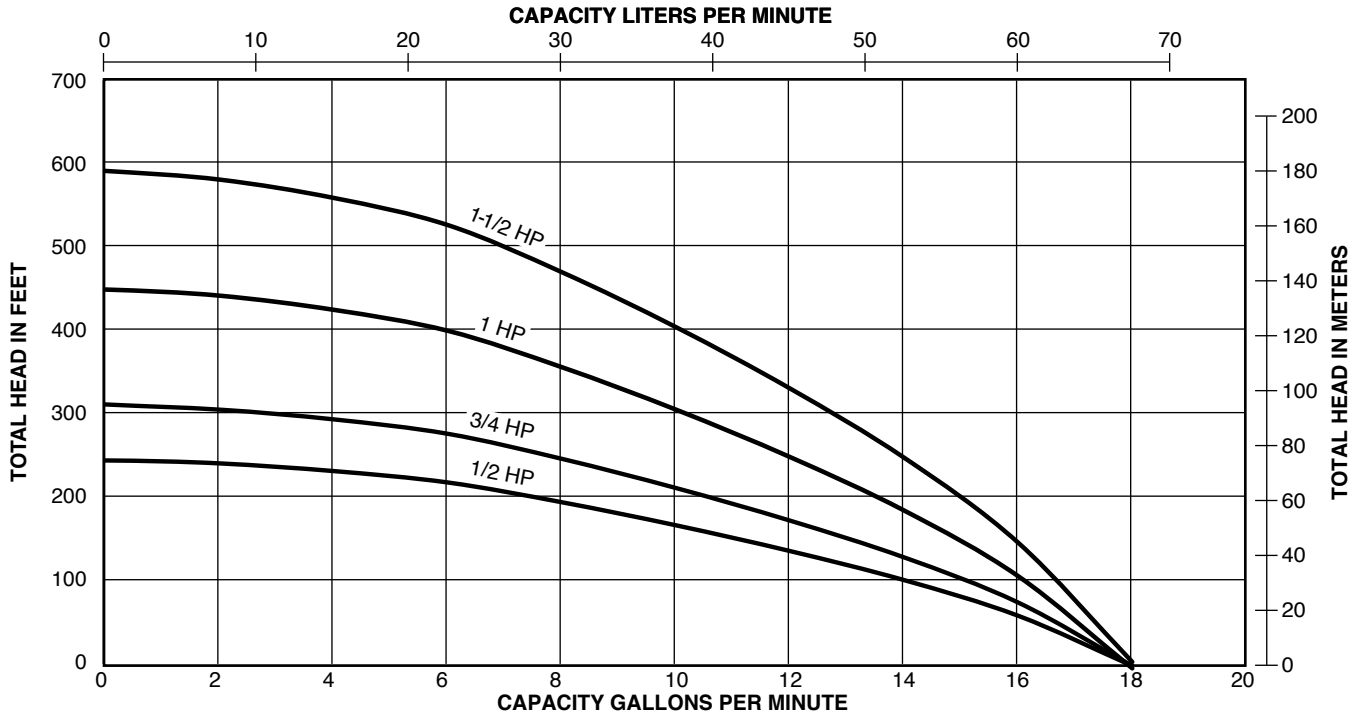

## CAPACITY IN GALLONS PER MINUTE

	PSI	Pumping Depth in Feet														
		0	20	40	60	80	100	125	150	175	200	250	300	350	400	500
<b>17 Stages, 1.5HP</b>	0	-	-	-	-	-	-	-	-	-	14.8	13.8	12.7	11.6	10.3	7.0
	20	-	-	-	-	-	-	-	14.9	14.4	13.9	12.8	11.7	10.4	8.9	4.8
	30	-	-	-	-	-	-	14.9	14.4	13.9	12.3	11.1	9.7	8.1	3.2	
	40	-	-	-	-	-	14.9	14.5	14.0	13.4	12.9	11.7	10.5	9.0	7.3	
	50	-	-	-	-	14.9	14.5	14.0	13.5	12.9	12.4	11.2	9.8	8.3	6.3	
	60	-	-	-	14.8	14.4	14.0	13.5	13.0	12.4	11.8	10.6	9.1	7.4	5.2	
	70	-	-	14.8	14.4	14.0	13.6	13.0	12.5	11.9	11.3	9.9	8.4	6.5	3.8	
	80	-	14.7	14.3	13.9	13.5	13.1	12.5	11.9	11.3	10.7	9.2	7.6	5.4		
<b>13 Stages, 1HP</b>	0	-	-	-	-	-	-	-	14.9	14.2	13.6	12.1	10.5	8.5	6.0	
	20	-	-	-	-	-	15.0	14.3	13.7	13.0	12.2	10.6	8.7	6.2		
	30	-	-	-	-	14.9	14.4	13.7	13.0	12.3	11.5	9.8	7.6	4.6		
	40	-	-	-	14.8	14.3	13.8	13.1	12.3	11.6	10.7	8.8	6.4	2.2		
	50	-	-	14.7	14.2	13.7	13.1	12.4	11.6	10.8	9.9	7.8	4.9			
	60	-	14.7	14.1	13.6	13.0	12.5	11.7	10.9	10.0	9.0	6.6	2.8			
	70	14.6	14.1	13.5	13.0	12.4	11.7	10.9	10.0	9.1	8.0	5.2				
	80	14.0	13.4	12.9	12.3	11.7	11.0	10.1	9.2	8.1	6.8	3.2				
<b>9 Stages, 0.75HP</b>	0	-	-	-	-	-	15.0	14.1	13.1	12.0	10.9	8.0	3.4			
	20	-	-	-	14.8	14.0	13.3	12.2	11.0	9.8	8.3	3.9				
	30	-	-	14.7	13.9	13.1	12.3	11.1	9.9	8.4	6.6					
	40	-	14.6	13.8	13.0	12.1	11.2	10.0	8.5	6.8	4.4					
	50	14.4	13.7	12.9	12.0	11.1	10.1	8.6	6.9	4.6						
	60	13.6	12.7	11.9	10.9	9.9	8.7	7.1	4.8							
	70	12.6	11.7	10.8	9.7	8.6	7.2	5.0								
	80	11.6	10.6	9.6	8.4	7.0	5.2									
<b>7 Stages, 0.5HP</b>	0	-	-	-	-	14.9	13.9	12.7	11.2	9.5	7.5					
	20	-	-	14.6	13.6	12.6	11.4	9.8	7.9	5.3						
	30	-	14.5	13.5	12.4	11.2	9.9	8.0	5.5							
	40	14.3	13.3	12.2	11.1	9.7	8.2	5.7								
	50	13.2	12.1	10.9	9.5	7.9	6.0									
	60	11.9	10.7	9.3	7.7	5.6	2.1									
	70	10.5	9.0	7.4	5.2											
	80	8.8	7.1	4.8												

# KS Series

Stainless Steel

## PUMP PERFORMANCE: 20 GPM

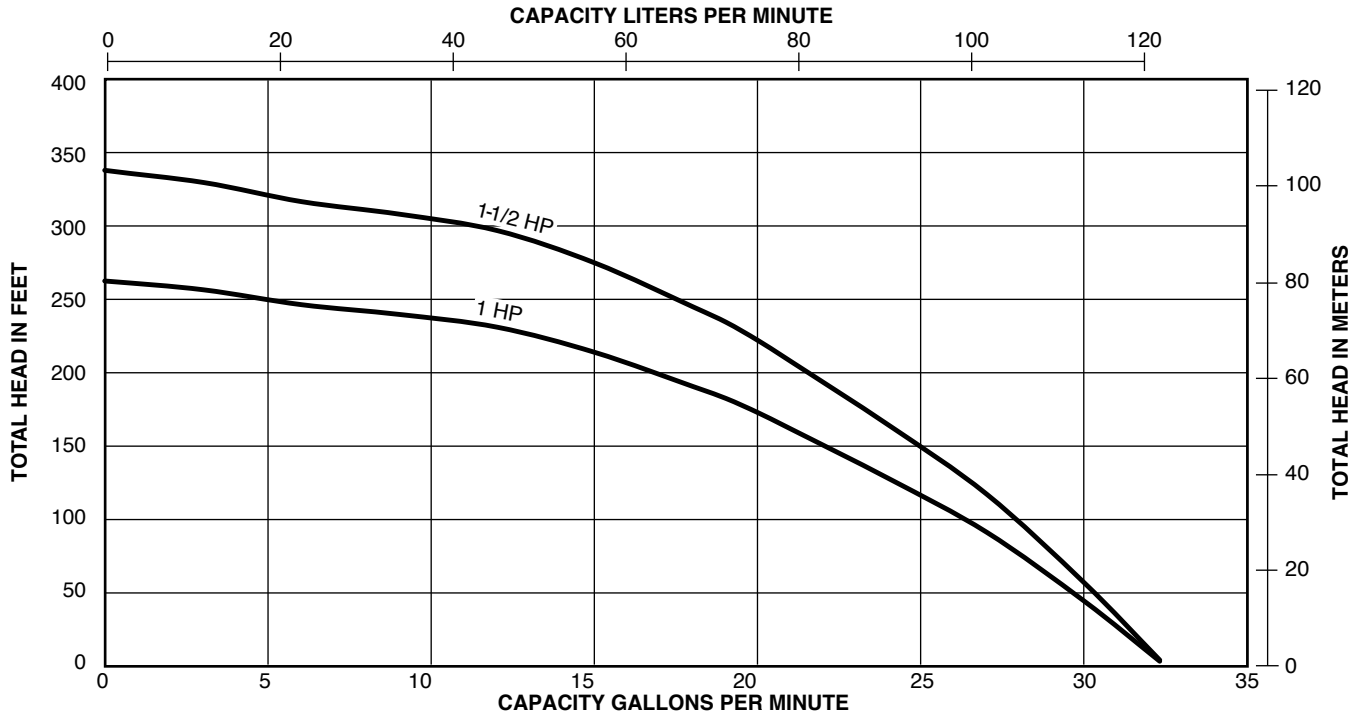

## CAPACITY IN GALLONS PER MINUTE

	PSI	Pumping Depth in Feet											
		0	20	40	60	80	100	125	150	175	200	250	300
<b>9 Stages, 1.5HP</b>	0	-	-	-	-	-	27.7	26.3	24.8	23.2	21.4	17.4	11.6
	20	-	-	-	27.4	26.2	25.0	23.4	21.7	19.8	17.7	12.2	
	30	-	-	27.2	26.0	24.8	23.6	21.9	20.0	17.9	15.4	8.0	
	40	-	27.0	25.9	24.6	23.4	22.0	20.1	18.0	15.6	12.7		
	50	26.8	25.7	24.5	23.2	21.8	20.3	18.2	15.8	12.9	8.9		
	60	25.5	24.3	22.9	21.5	20.0	18.4	16.0	13.2	9.2			
	70	24.1	22.7	21.3	19.8	18.1	16.2	13.4	9.6				
	80	22.5	21.1	19.5	17.8	15.9	13.7	10.0					
<b>7 Stages, 1HP</b>	0	-	-	-	-	27.6	26.1	24.1	22.0	19.5	16.7	7.4	
	20	-	-	27.1	25.6	24.0	22.3	19.9	17.1	13.7	8.6		
	30	-	26.9	25.4	23.8	22.0	20.1	17.4	14.0	9.1			
	40	26.7	25.1	23.5	21.7	19.8	17.6	14.3	9.6				
	50	24.9	23.2	21.4	19.5	17.2	14.6	10.1					
	60	23.0	21.2	19.1	16.8	14.1	10.5						
	70	20.9	18.8	16.5	13.6	9.8							
	80	18.5	16.1	13.1	9.0								

# KS Series

Stainless Steel

## OUTLINE DIMENSIONS



DISCHARGE		
GPM	NPT	"D"
10	1-1/4	3-7/8
20	1-1/4	3-7/8

For lengths, refer to Ordering Information tables.  
Dimensions (in inches) are for estimating purposes only.

# ST.E.P. Plus D Series

4" multi-stage submersible effluent pumps



The ST.E.P. Plus D Series 4" submersible pump in 10, 20 and 30 GPM models dominate with superior "draw-down" capability, with reduced amp draw and with cooler and quieter operation.

## APPLICATIONS

**Clean and Gray Water...** for residential, commercial, and agricultural use.

## SPECIFICATIONS

**Motor:** Available in 115 or 230 volt versions. Dry-wound, double ball-bearing, double-seal and thermal overload protected, UL and CSA approved.

**Shell:** Stainless steel (300 grade)

**Discharge:** 1-1/4" Fiberglass-reinforced thermoplastic

**Discharge Bearing:** Nylatron®

**Impellers:** Acetal

**Diffusers:** Polycarbonate

**Suction Caps:** Polycarbonate with stainless steel wear ring

**Thrust Pads:** Proprietary spec.

**Shaft and Coupling:** Stainless steel 300 grade

**Intake:** Fiberglass-reinforced thermoplastic

**Intake Screen:** Stainless steel

**Jacketed Cord:** 600 Volt "SJOW" jacketed 10' leads, 2-wire with ground

**Agency Listing:** CSA

## FEATURES

**ST.E.P. Plus DOMINATES with a...**

**Proven Stage System:** The proven SignaSeal staging system utilizes a patented ceramic wear surface. When incorporated with STA-RITE's "true" independent floating impellers, dominates with 1st-in-class performance, superior sand handling, and a thrust management staging system with industry exclusive "dry-run" capabilities.

**Superior "draw-down" capability:** The ST.E.P. Plus Dominates in this class with the lowest draw-down of 4-1/2" (a standard 4" NEMA submersible only draws-down to 13-1/2").

**Reduced amp draw:** The ST.E.P. Plus Dominates in this class with less energy consumption – over 25% less amp draw (9.5 amps vs. 12.7 amps, 115 volt) than a 4" NEMA submersible, reducing operating costs and extending the service life of float switch contacts.

**Cooler and quieter operation:** The ST.E.P. Plus Dominates by using the pumped liquid to cool the motor as it passes over the motor. The water passing over the motor dampens the motor noise, eliminating expensive "flow-inducer sleeves" required when using a standard 4" NEMA submersible.

**Impellers:** Precision molded for perfect balance... ultra smooth for the highest performance and efficiency. Allows for .080" solids.

**Shaft:** Positive drive, hexagonal 7/16" – 300-grade stainless steel shaft offers generous impeller drive surfaces.

**Shaft bearing:** Exclusive self-lubricating Nylatron® bearing resists wear surface from sand and abrasives.

**Shell:** Corrosion resistant 300-grade stainless steel.

## ORDERING INFORMATION

Catalog Number	HP	Max. Load Amps	Volts	Phase/Cycles	Cord Length	Pallet Quantity	Weight (Lbs.)
10DOM05121	1/2	11.0	115	1/60	10'	40	17
20DOM05121+1	1/2	10.6	115	1/60	10'	40	17
30DOM05121	1/2	9.5	115	1/60	10'	40	19
10DOM05221	1/2	5.5	230	1/60	10'	40	17
20DOM05221+1	1/2	5.3	230	1/60	10'	40	17
30DOM05221	1/2	4.6	230	1/60	10'	40	19
10DOM07221	3/4	7.3	230	1/60	10'	40	23
20DOM07221	3/4	6.5	230	1/60	10'	40	19
30DOM07221	3/4	5.6	230	1/60	10'	40	18
10DOM10221	1	9.6	230	1/60	10'	40	34
20DOM10221	1	7.7	230	1/60	10'	40	23
30DOM10221	1	7	230	1/60	10'	40	22

In order to provide the best products possible, specifications are subject to change.

Pentair trademarks and logos are owned by Pentair plc or its affiliates. All other third party registered and unregistered trademarks and logos are the property of their respective owners.

# ST.E.P. Plus D Series

4" multi-stage submersible effluent pumps

## PUMP PERFORMANCE: 10 GPM

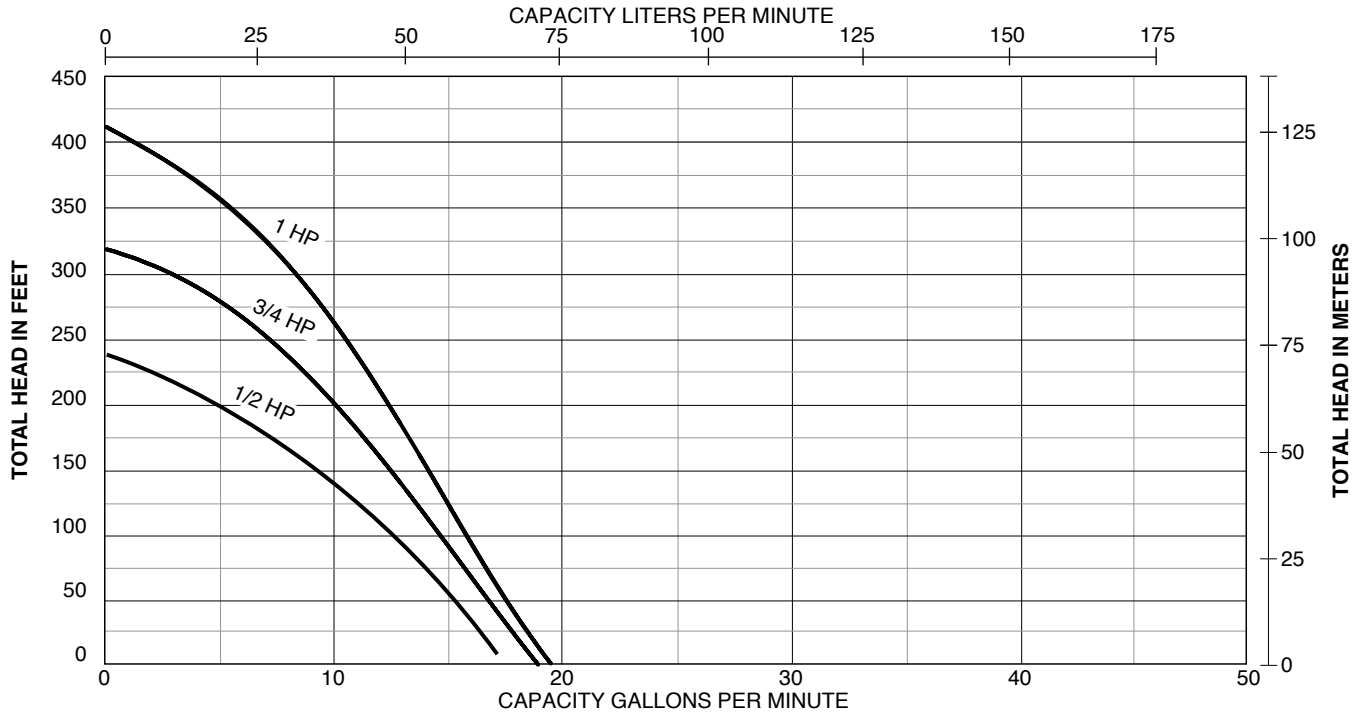

## PUMP PERFORMANCE: 20 GPM

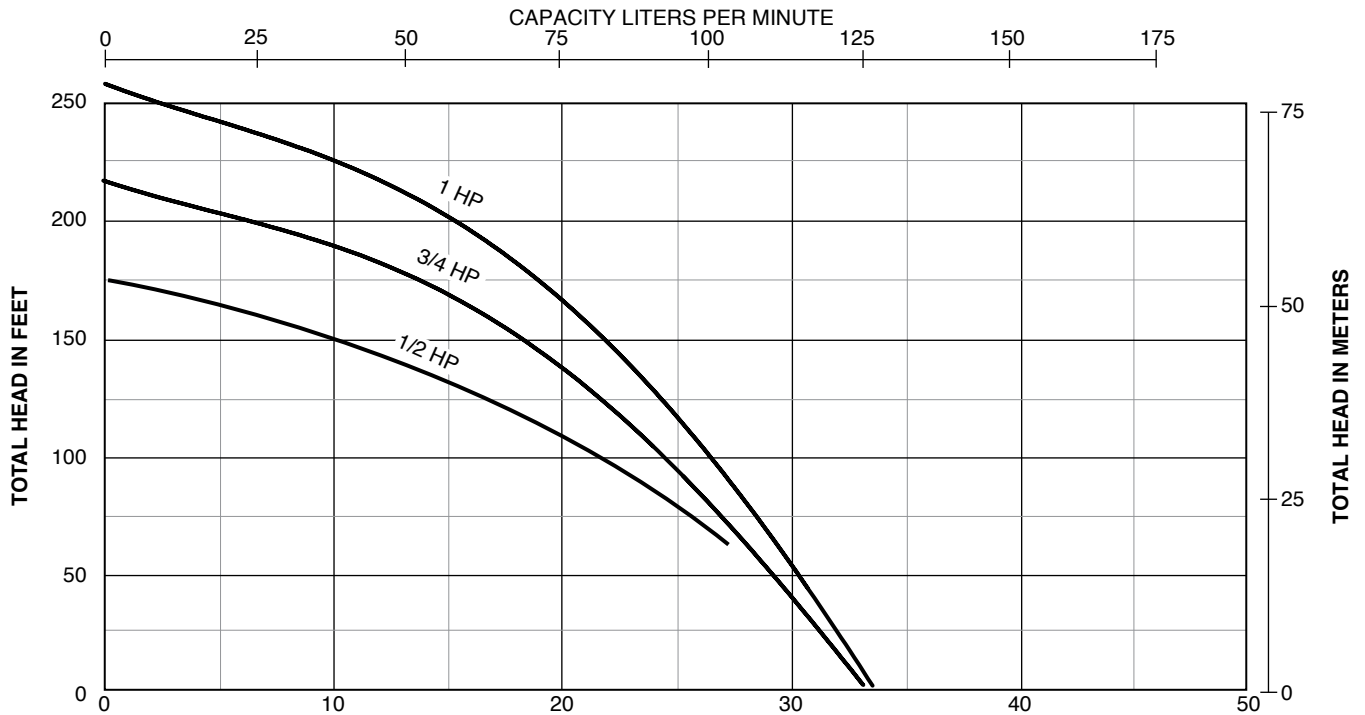

# ST.E.P. Plus D Series

4" multi-stage submersible effluent pumps

**PUMP PERFORMANCE: 30 GPM**

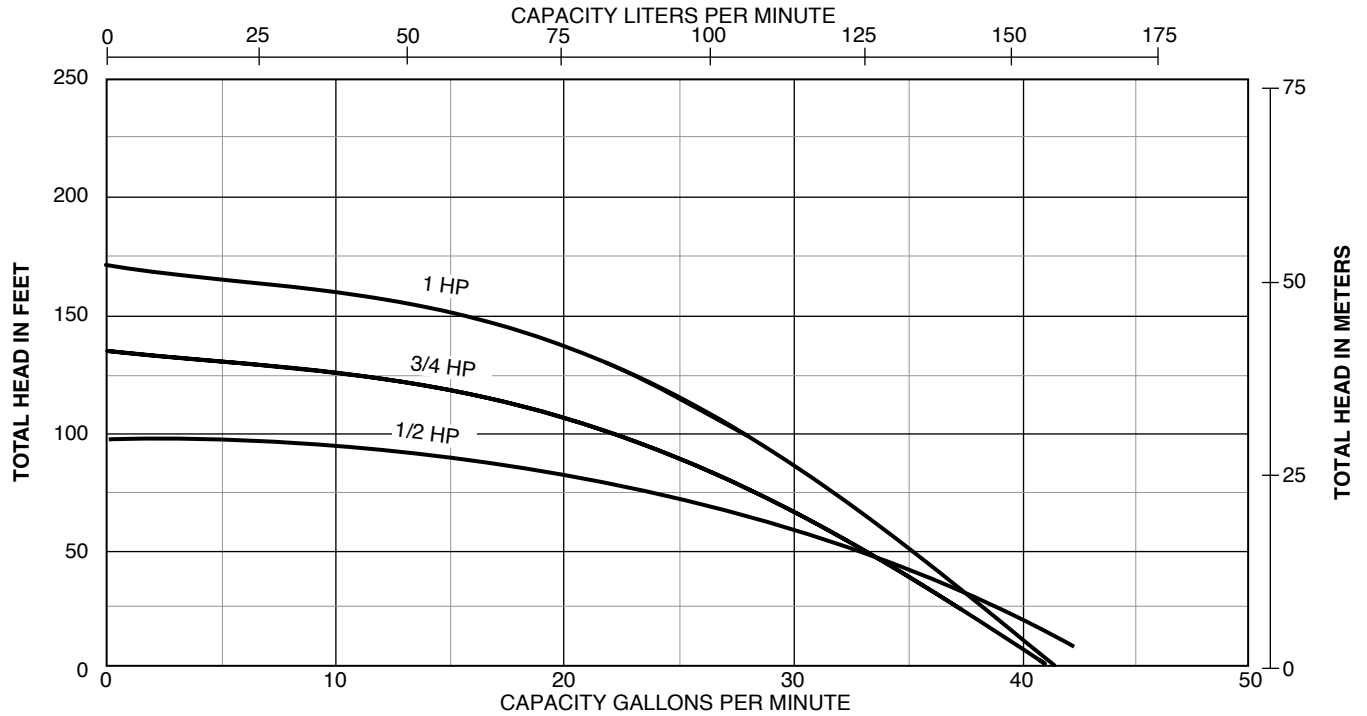

**PUMP PERFORMANCE** (Capacity in gallons per minute)

HP	Flow Rate	0	10	20	30	40	50	60	70	80	90	100	110	120	130	140	150	160
1/2	10	-	-	15.0	13.7	12.7	11.5	10.2	8.4	6.5	4.3	1.0						
3/4	10	-	-	17.1	16.1	15.2	14.2	13.1	12	10.8	9.6	8.2	6.7	5.1	3.1	0.7		
1	10	-	-	17.2	16.6	15.9	15.2	14.5	13.7	12.9	12.1	11.2	10.3	9.3	8.2	6.9	5.6	3.9
1/2	20	-	-	30.0	27.5	24.0	20.0	13.5	6.0									
3/4	20	-	-	29.5	27.4	25	22.4	19.5	16.1	11.9	5.0							
1	20	-	-	30.4	28.7	26.9	24.9	22.8	20.4	17.7	14.5	10.4						
1/2	30	-	38.5	33.3	25.8	16.0												
3/4	30	-	38.1	34	29.3	23.7	16.1											
1	30	-	39.1	36.1	32.8	29.1	24.7	19.3	11.1									

# ST.E.P Plus D Series

4" multi-stage submersible effluent pumps

## OUTLINE DIMENSIONS

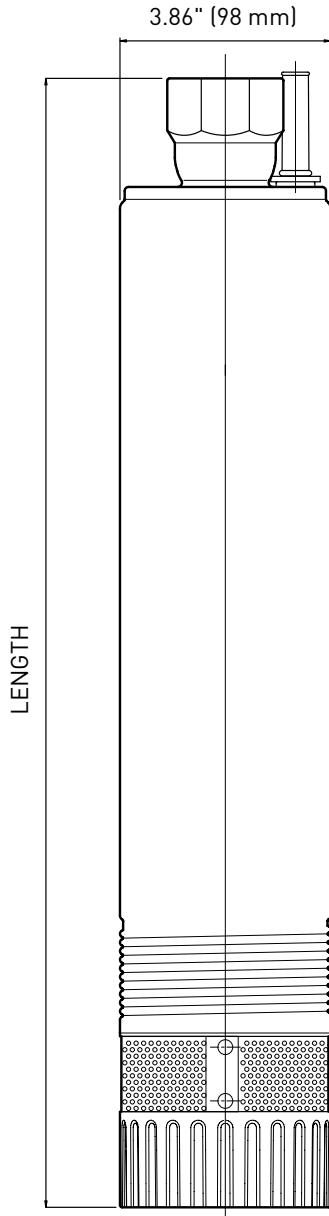

## CROSS SECTION

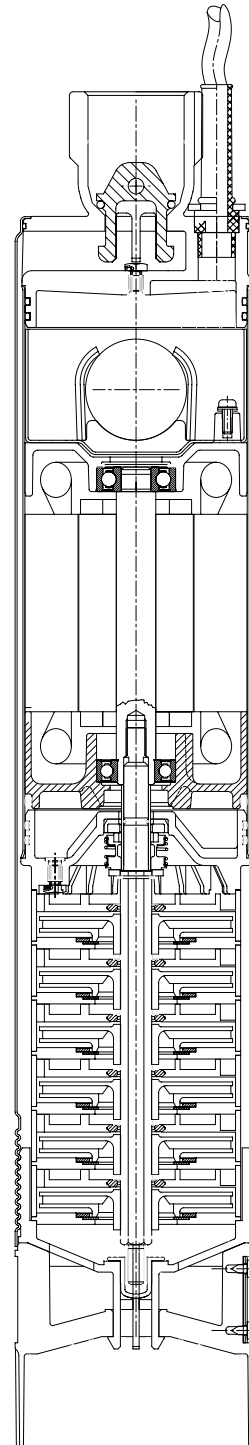

Pump	Length
10DOM05121	21.6
20DOM05121+1	22.3
30DOM05121	20.6
10DOM05221	21.6
20DOM05221+1	22.3
30DOM05221	20.6
10DOM07221	25.2
20DOM07221	24.9
30DOM07221	22.3
10DOM10221	29.0
20DOM10221	27.2
30DOM10221	24.6

Dimensions are for estimating purposes only.

# ST.E.P Plus D Series

4" multi-stage submersible effluent pumps

## INCREASED DRAWDOWN

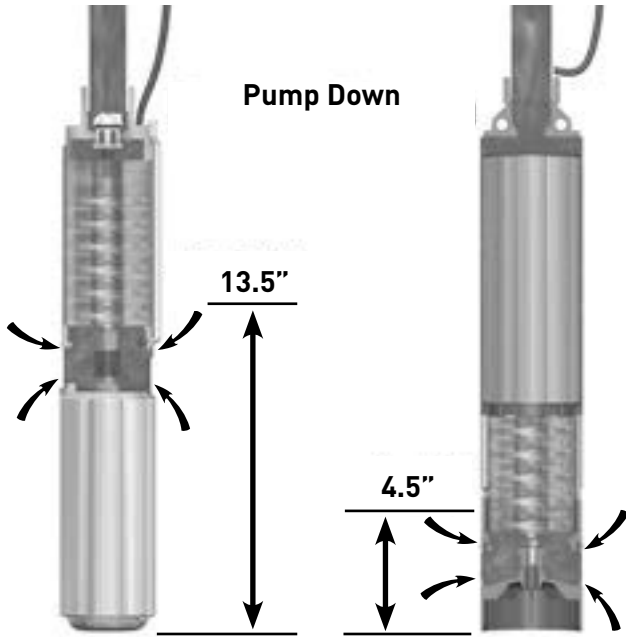

## REDUCED AMP DRAW

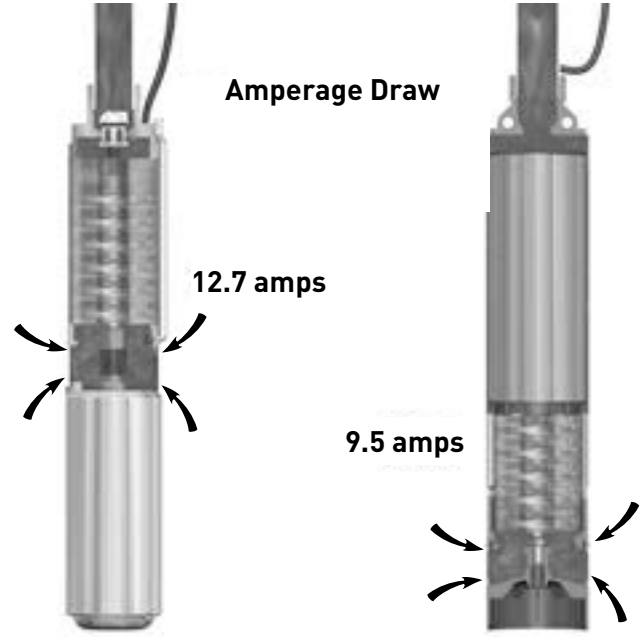

## ELIMINATES FLOW-INDUCER

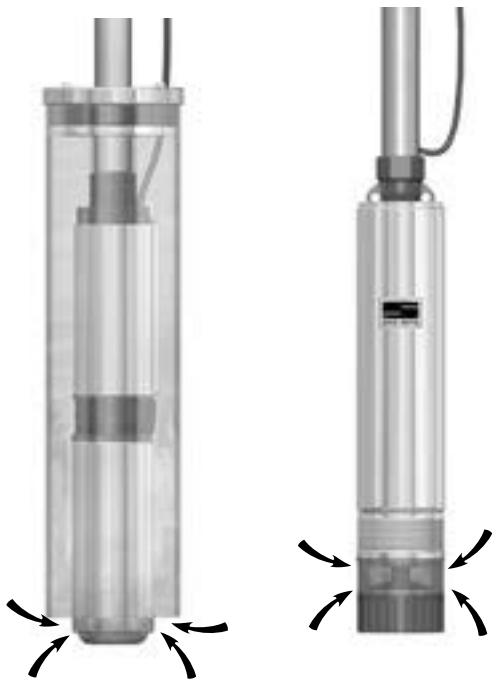

## ADJUSTABLE DEPTH SETTING

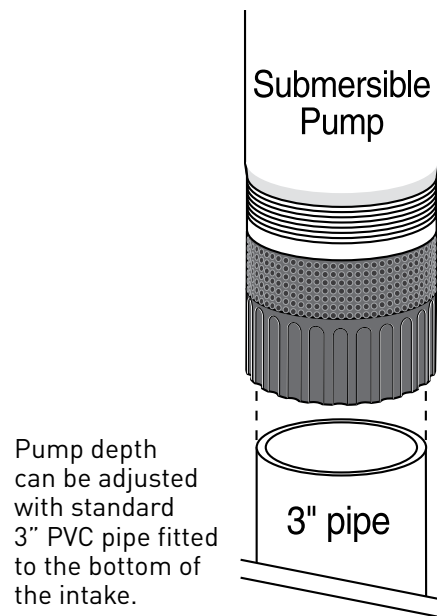

# 70 GPM Series

Cast Iron



**Precision-engineered, quality-built and rugged 70 GPM Series submersibles may be used in wells 4" or larger. Maximum outside diameter 3-7/8".**

## APPLICATIONS

**Water systems...**for residential, industrial, commercial, multiple housing and farm use.

## SPECIFICATIONS

**Discharge:** Cast iron, ASTM A48 Class 30

**Pump Bowls:** Cast iron, ASTM A48 Class 30

**Impellers:** Polycarbonate with brass insert

**Collets:** Stainless steel, AISI 416

**Upthrust Bearing:** Bronze, ASTM B255 Type II

**Pump Shaft:** Stainless steel, AISI 416

**Bowl and Intake Bearings:** Nitrile (proprietary spec.)

**Lead Guard:** Stainless steel, AISI 430

**Intake Bracket:** Cast iron, ASTM A48 Class 30

**Screen:** Stainless steel, AISI 430

**Pump/Motor Coupling:** Stainless steel, AISI 416

## FEATURES

**Discharge:** Heavy-duty cast iron construction provides smooth water passage to column pipe. NPT threads standard.

**Bowl and Intake Bearings:** Fluted, cutless rubber type assures superior abrasive-handling characteristics, located at each stage.

**Polycarbonate Impellers:** Glass-reinforced polycarbonate resists abrasives and provides smooth water passages for minimum friction loss. Ensures optimum pump efficiency.

**Pump Bowls:** Highly efficient hydraulic design...threaded bowl design in gray cast iron.

**Upthrust Bearing:** Bronze upthrust bearing provides positive momentary upthrust protection during start-up.

**Intake Bracket:** Efficient hydraulic design minimizes entrance losses, ensuring maximum pump performance.

**Stainless Steel Pump Shaft:** Precision straightened shaft is corrosion-resistant stainless steel.

**Pump/Motor Coupling:** Stainless steel for maximum corrosion resistance...precision machined to ensure accurate alignment and power transfer.

**Intake Screen:** Stainless steel material offers maximum corrosion resistance...protects against damaging solids entering the pump assembly.

# 70 GPM Series

Cast Iron

**PUMP PERFORMANCE: 70 GPM**

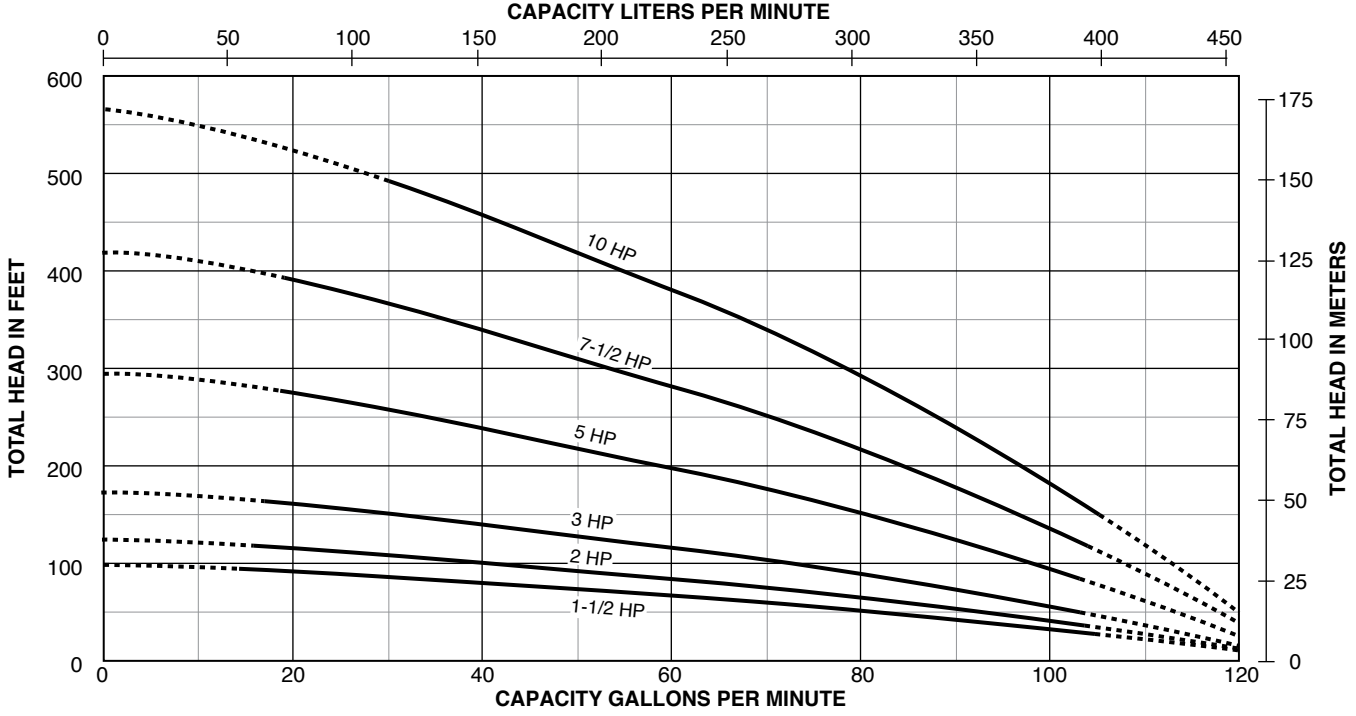

Tested and rated in accordance with Water Systems Council Standards.

NOTE: Pumps installed with a Pro-Source® tank require a 100 PSI relief valve. Pumps installed with a conventional tank require a 75 PSI relief valve. Relief valve must be capable of relieving entire flow of pump at relief pressure.

# 70 GPM Series

Cast Iron

## ORDERING INFORMATION

MOTOR TYPE	HP	STGS.	PH	VOLT	PUMP END			MOTOR		CONTROL BOX		
					CATALOG NUMBER	LENGTH INCHES*	WEIGHT POUNDS*	CATALOG NUMBER	WEIGHT POUNDS*	CATALOG NUMBER	WEIGHT POUNDS*	
2 WIRE	1-1/2	4	1	230	L70F4	20-25/32	26	P42B0015A2	29			
	1-1/2	4	1	230	L70F4	20-25/32	26	P43B0015A2	27	SMC-CR1521	7	
	1-1/2	4	3	230	L70F4	20-25/32	26	P43B0015A3	23			
	1-1/2	4	3	460	L70F4	20-25/32	26	P43B0015A4	23			
	3 WIRE	2	5	1	230	L70G4	24-1/16	31	P43B0020A2	31	SMC-CR2021	7
		2	5	3	230	L70G4	24-1/16	31	P43B0020A3	27		
2		5	3	460	L70G4	24-1/16	31	P43B0020A4	27			
3		7	1	230	L70H4	30-5/8	39	P43B0030A2	40	SMC-CR3021	7	
3		7	3	230	L70H4	30-5/8	39	P43B0030A3	32			
3		7	3	460	L70H4	30-5/8	39	P43B0030A4	32			
5		5	12	1	230	L70J4	47-1/32	60	P43B0050A2	70	SMC-CR5021	8
		5	12	3	230	L70J4	47-1/32	60	P43B0050A3	55		
		5	12	3	460	L70J4	47-1/32	60	P43B0050A4	55		
		7-1/2	17	3	230	L70K4	63-7/16	81	P43B0075A3	70		
		7-1/2	17	3	460	L70K4	63-7/16	81	P43B0075A4	70		
		10	23	3	460	L70L4	83-1/8	106	P43B0100A4	70		

\*Length and Weight are approximate.

NOTE: Pump end and motor purchased separately.

## OUTLINE DIMENSIONS

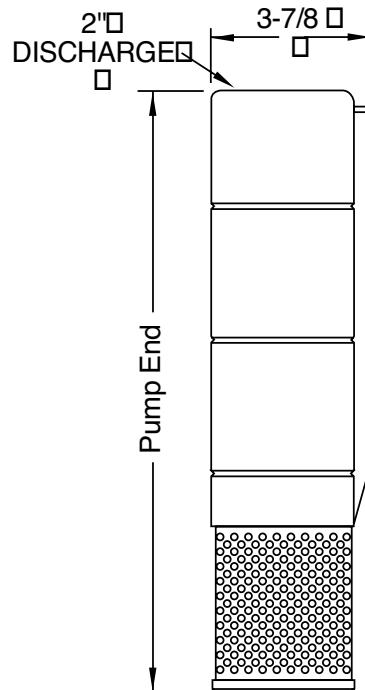

For lengths, refer to Ordering Information tables.

Dimensions (in inches) are for estimating purposes only.

# 70 GPM Series

Cast Iron

70 GALLONS PER MINUTE		PUMP PERFORMANCE (Capacity in gallons per minute)																						
HP	PSI	PUMPING DEPTH IN FEET																						
		20	40	60	80	100	125	150	175	200	225	250	275	300	325	350	375	400	425	450	475	500	525	550
1-1/2	0	—	92.5	70.0	40.0																			
	20	61.5	31.0																					
	30	25.0																						
	40																							
	50																							
	60																							
2	0	—	100.0	85.0	64.0	40.0																		
	20	79.0	57.0	32.5																				
	30	52.5	28.0																					
	40	25.0																						
	50																							
	60																							
3	0	—	104.0	98.0	86.0	73.5	52.5	31.0																
	20	95.0	82.5	68.0	52.0	35.0																		
	30	81.0	66.0	49.0	32.0																			
	40	64.0	47.0	29.0																				
	50	43.0	25.5																					
	60	22.0																						
5	0	—	—	—	106.0	99.0	91.0	82.0	72.0	60.0	47.5	35.0	21.0											
	20	—	104.0	97.0	90.5	83.5	74.0	62.0	49.5	37.0	23.0													
	30	102.5	96.0	88.5	82.5	74.5	63.0	50.0	38.0	25.0														
	40	95.0	87.5	81.5	73.5	64.0	51.5	39.0	26.0															
	50	86.0	80.0	72.0	62.0	52.0	39.5	27.0																
	60	78.0	70.0	61.0	50.0	40.0	27.5																	
7-1/2	0	—	—	—	—	108.0	103.0	97.0	91.0	85.0	78.0	75.0	62.5	54.0	45.5	35.5								
	20	—	—	108.0	102.5	97.5	92.0	86.0	80.0	76.0	64.9	56.0	47.0	37.5	27.5									
	30	—	107.5	102.0	97.0	92.5	87.0	80.5	76.5	65.0	56.5	47.5	38.0	28.0										
	40	107.0	101.5	96.5	92.0	87.5	81.5	77.0	65.5	57.0	48.0	38.5	29.0											
	50	101.0	96.0	91.0	86.0	82.0	77.0	66.0	57.5	48.0	39.0	30.0	20.0											
	60	95.0	90.0	85.0	80.5	77.5	66.5	57.5	49.0	40.0	31.0	21.0												
10	0	—	—	—	—	—	110.0	106.0	102.0	97.5	93.0	88.0	84.0	79.0	74.9	68.0	62.0	55.0	48.0	42.5	36.0			
	20	—	—	—	110.0	107.0	102.5	98.5	93.5	89.0	85.0	80.0	75.5	69.5	62.5	56.0	49.5	43.0	37.0	31.0				
	30	—	—	109.5	106.5	103.0	99.0	94.0	89.5	85.0	80.5	76.0	70.0	63.0	57.0	55.0	43.5	37.5	31.5					
	40	—	109.0	106.0	102.5	99.5	95.0	90.0	85.5	81.0	76.5	70.5	64.0	57.5	51.0	44.0	38.0	32.0						
	50	108.0	105.5	102.0	98.5	95.0	90.0	86.0	81.5	76.5	71.0	64.5	57.5	51.5	44.5	38.0	32.5							
	60	104.5	101.5	98.0	94.0	91.0	86.5	82.0	77.0	72.0	65.0	58.0	52.0	46.0	38.5	32.5								

CAUTION: DO NOT use pump at flow rates indicated by the symbol '—'. To do so can cause premature failure of unit. Pump warranty void when failure occurs under these conditions.

Tested and rated in accordance with Water Systems Council Standards.

NOTE: Pumps installed with a Pro-Source® tank require a 100 PSI relief valve. Pumps installed with a conventional tank require a 75 PSI relief valve. Relief valve must be capable of relieving entire flow of pump at relief pressure.

# 75 and 90 GPM Series

Stainless steel, High-Flo 4"



The 75 and 90 GPM Stainless Steel High-Flo 4" Submersible Pumps deliver efficient and dependable performance even in rough, aggressive water. Heads to 410 feet and capabilities to 120 GPM. Built to deliver long-term, trouble-free service. FDA-compliant engineered composite and stainless steel components.

## APPLICATIONS

**Water systems...**for residential, industrial, commercial, multiple housing and farm use.

## SPECIFICATIONS

**Discharge:** 300 grade stainless steel with 2" NPT threads

**Top Bearing:** Acetal

**Top Bearing Journal:** 300 grade stainless steel

**Diffuser Assembly:** Noryl® (20% glass filled) with urethane insert and 300 grade stainless steel

**Upthrust Washers:** Phenolic

**Impellers:** Polycarbonate (20% glass filled)

**Impeller Eye Seals:** Urethane

**Bowls:** Noryl (20% glass filled)

**Intermediate Bearing:** Acetal

**Intermediate Bearing Journal:** 300 grade stainless steel

**Shaft:** 300 grade stainless steel

**Coupling:** 300 grade stainless steel, 7/16" hex stock

**Shell:** 300 grade stainless steel

**Motor Adapter:** 300 grade stainless steel

**Suction Screen:** 300 grade stainless steel

**Cable Guard:** 300 grade stainless steel

**Fasteners:** 300 grade stainless steel

## FEATURES

**Discharge:** Heavy-duty 300 grade stainless steel construction provides smooth water passage to column pipe. Large wrench flats and rope hole.

**Top Bearing:** Field-proven, sealed and lubricated top bearing assembly keeps abrasives out, ensuring long bearing life.

**Impellers:** 20% glass-reinforced polycarbonate to resist abrasives and provide smooth water passage for minimal friction loss.

**Upthrust Bearing:** Phenolic washers and stainless steel upthrust rings at each stage provide excellent wear-resistant surfaces.

**Diffuser Bearing:** Urethane bearings at each stage provide radial protection and stability, and excellent resistance to sand damage.

**Motor Bracket:** 300 grade precision cast stainless steel. Incorporates an efficient hydraulic design for maximum volume and access to motor mounting nuts.

**Shaft:** 300 grade "treated" stainless steel pump shaft is corrosion-resistant. The hex shape offers generous impeller drive surfaces.

**Motor Coupling:** Pressed-on, sintered 300 grade stainless steel for maximum corrosion resistance provides trouble-free transfer of power between motor and pump shaft.

**Shell:** Heavy-gauge, 300 series stainless steel pump shell is durable and offers high corrosion resistance.

**Intake Screen:** 300 series stainless steel material offers maximum corrosion resistance and protects against damaging solids entering the pump.

# 75 and 90 GPM Series

Stainless steel, High-Flo 4"

## ORDERING INFORMATION

MOTOR TYPE	HP	STGS.	PH	VOLT	PUMP END			MOTOR		CONTROL BOX	
					CATALOG NUMBER	LENGTH INCHES*	WEIGHT POUNDS*	CATALOG NUMBER	WEIGHT POUNDS*	CATALOG NUMBER	WEIGHT POUNDS*
<b>75 GPM</b>											
<b>3 WIRE</b>	2	5	1	230	L75HF20	16-5/8	15	P43B0020A2	32	SMC-CR2021	7
			3	230	L75HF20	16-5/8	15	P43B0020A3	29		
			3	460	L75HF20	16-5/8	15	P43B0020A4	29		
	3	7	1	230	L75HF30	20-7/8	11	P43B0030A2	52	SMC-CR3021	8
			3	230	L75HF30	20-7/8	11	P43B0030A3	44		
			3	460	L75HF30	20-7/8	11	P43B0030A4	44		
	5	11	1	230	L75HF50	29-3/8	15	P43B0050A4	69	SMC-CR5021	14
			3	230	L75HF50	29-3/8	15	P43B0050A3	55		
			3	460	L75HF50	29-3/8	15	P43B0050A4	55		
	7-1/2	17	3	230	L75HF75	42	32	P43B0075A3	70		
			3	460	L75HF75	42	32	P43B0075A4	70		
	<b>90 GPM</b>										
<b>3 WIRE</b>	2	5	1	230	L90HF20	21	15	P43B0020A2	31	SMC-CR2021	7
			3	230	L90HF20	21	15	P43B0020A3	31		
			3	460	L90HF20	21	15	P43B0020A4	31		
	3	7	1	230	L90HF30	26-5/8	17	P43B0030A2	40	SMC-CR3021	7
			3	230	L90HF30	26-5/8	17	P43B0030A3	32		
			3	460	L90HF30	26-5/8	17	P43B0030A4	32		
	5	12	1	230	L90HF50	41-1/2	19	P43B0050A2	70	SMC-CR5021	8
			3	230	L90HF50	41-1/2	19	P43B0050A3	55		
			3	460	L90HF50	41-1/2	19	P43B0050A4	55		
	7-1/2	17	3	230	L90HF75	56	26	P43B0075A3	70		
			3	460	L90HF75	56	26	P43B0075A4	70		
	10	23	3	460	L90HF100	72-3/8	35	P43B0100A4	78		

\*Length and Weight are approximate.

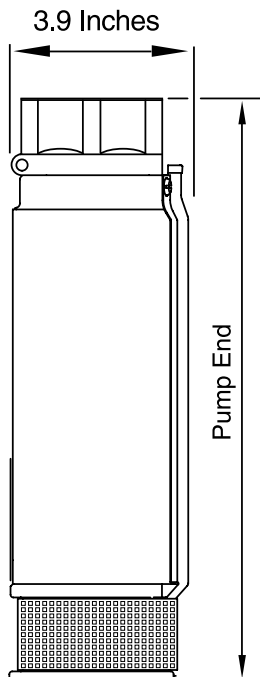

2" NPT Discharge, all models

For lengths, refer to Ordering Information tables.

Dimensions are for estimating purposes only.

# 75 and 90 GPM Series

Stainless steel, High-Flo 4"

**PUMP PERFORMANCE** (Capacity in gallons per minute)

HP	PSI	PUMPING DEPTH IN FEET													SHUT-OFF HEAD	
		20	40	60	80	100	125	150	175	200	250	300	350	400	FEET	PSI
<b>75 GPM</b>																
2	0	82	76	70	62	52									143	62
	20	67	59	49												
	30	58	47													
	40	45														
	50															
	70															
3	0	-	-	-	78	70	60	50							226	98
	20	-	76	67	59	51	40									
	30	75	66	58	50	41										
	40	65	57	49	40											
	50	55	46													
	70	45														
5	0	-	-	-	-	-	78	73	66	59					333	144
	20	-	-	-	78	74	67	60	53							
	30	-	-	77	73	68	60	53	45							
	40	80	76	72	67	61	54	45								
	50	75	71	67	60	54	45									
	70	46	59	53	45											
7-1/2	0	-	-	-	-	-	-	81	77	69	60	49			482	209
	20	-	-	-	-	-	82	78	73	70	61	51				
	30	-	-	-	-	82	78	74	70	66	57	45				
	40	-	-	-	82	79	75	71	67	62	52	39				
	50	-	-	81	78	75	71	67	62	58	45					
	70	80	77	73	70	68	64	58	52	46						
<b>90 GPM</b>																
2	0	-	115	90	60										109	48
	20	80	53													
	30	50														
	40															
	50															
	60															
3	0	-	-	113	96	75	50								153	67
	20	108	90	69	50											
	30	87	66													
	40															
	50															
	60															
5	0	-	-	-	-	115	103	86	72	56					258	112
	20	-	122	112	102	88	74	59								
	30	119	111	101	87	73	58									
	40	108	98	84	72	57										
	50	96	83	71	56											
	60	82	70	55												
7-1/2	0	-	-	-	-	124	116	108	103	92	73	50			402	175
	20	-	-	122	116	110	101	93	87	74	52					
	30	-	121	115	109	102	94	84	79	65						
	40	120	114	108	101	94	85	76	70	54						
	50	113	107	100	93	86	76	66	60							
	60	106	99	92	85	77	67	56								
10	0	-	-	-	-	-	-	118	112	99	81	66	52		491	213
	20	-	-	-	-	-	119	113	106	100	83	67	53			
	30	-	-	-	-	120	114	107	101	93	75	60				
	40	-	-	-	119	114	107	101	94	84	68	54				
	50	-	-	118	114	108	102	95	85	77	62					
	60	125	117	113	108	102	94	86	78	70	55					

# 75 and 90 GPM Series

Stainless steel, High-Flo 4"

## PUMP PERFORMANCE: 75 GPM

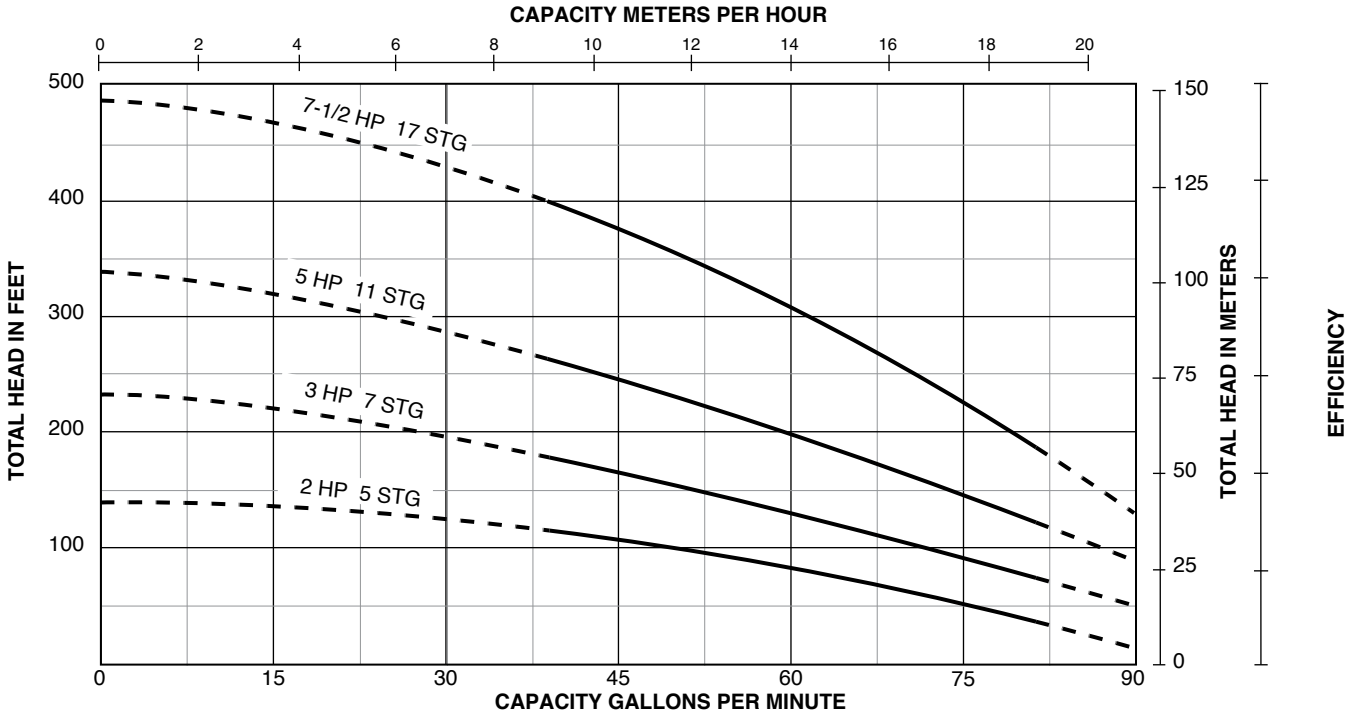

## PUMP PERFORMANCE: 90 GPM

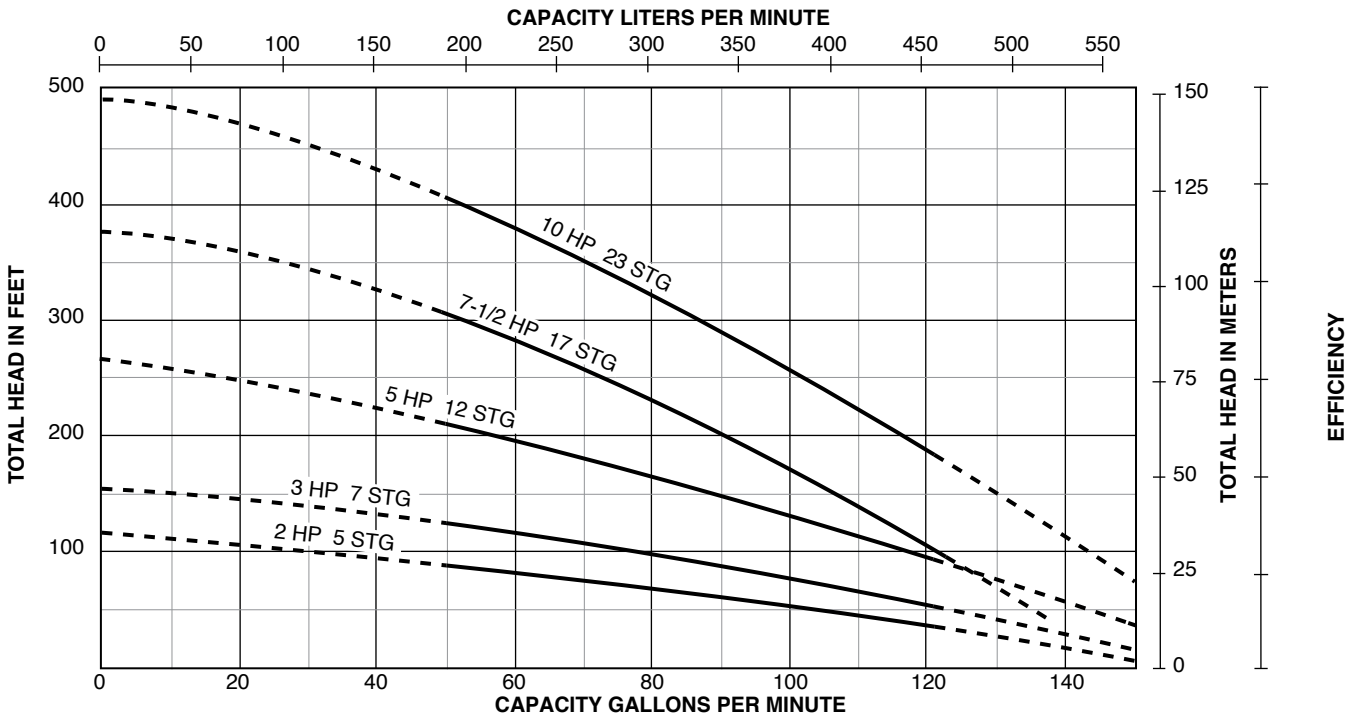

Tested and rated in accordance with Water Systems Council Standards.

NOTE: Pumps installed with a Pro-Source® tank require a 100 PSI relief valve. Pumps installed with a conventional tank require a 75 PSI relief valve. Relief valve must be capable of relieving entire flow of pump at relief pressure.

# 4"x6" Submersible Motor Adapter

Stainless Steel



The PKG 4x6, Pump/Motor Adapter offers the professional distributor and dealer the flexibility to stock standard 4" submersible pump ends, and 4" and 6" motors, better utilizing inventory dollars and delivery demands!

## APPLICATIONS

**Water systems...**for residential, industrial, commercial, multiple housing and farm use.

## ORDERING INFORMATION

CATALOG NUMBER	PUMP END*	MOTOR*	MAXIMUM HP	WEIGHT POUNDS**
PKG 4x6	4" NEMA	6" NEMA	10	5

\*Pump end and motor ordered separately.

\*\*Shipping weight is approximate.

## FEATURES

### Extends Single-Phase Power

**Availability:** To all Signature 2000® submersibles through 10 HP using 6" single-phase motors.

**Easy Assembly:** Easy job-site assembly.

**Double-Suction Screens:** Reduces inlet suction velocity, reducing the amount of suspended solids ingested by pump.



# Pentek® XE Series™ Motors

Stainless Steel



Built with the latest design, manufacturing and testing technology, they feature laser-welded 304L stainless steel construction, higher thrust capacities and higher efficiencies. The Pentek XE Series submersible motors incorporate “encapsulated, epoxy stator design,” and professional-grade Class F insulation provides longer life in harsh environments. Each motor is 100% factory pressure and run tested to support our quality standards.

## APPLICATIONS

**Water systems...**for residential, industrial, commercial, multiple housing and farm clean water use.

## SPECIFICATIONS

**End Bell:** 304 stainless steel over cast iron

**Shell:** 304 stainless steel

**Motor Shaft:** 17-4 precipitation hardened stainless steel

**Winding:** Copper

**Insulation:** Class F, 311°F (155°C)

**Max. Water Temp:** 86°F (30°C)

**Fasteners:** 304 stainless steel

**Sand Boot:** Nitrile

**Cable:** Field-serviceable, Controlled Compression Design, UL and CSA Approved

**Cable Length:** 48"

**Diaphragm:** EPDM

**Thrust Bearings:** Kingsbury-type, pivot shoe, carbon graphite mating ring

**Thrust Load Capacity:** 700 lbs.

## FEATURES

**700# Rated Kingsbury Thrust Bearing Design:** Large high-performance bearings are standard on all HPs allowing for higher thrust loads, providing many years of trouble-free service under severe-duty operation.

**2-Wire Permanent Split Capacitor:**

Design insures quiet operation and improved operating efficiency.

**3-Wire Motors:** Operate with Pentek SMC and other single-phase motor controls.

**All Stainless Steel Exterior**

**Professional-Grade Class F-Compliant Motor Insulation:** Allows for longer service life.

**UL, CSA Approved and NSF/ANSI 61 Certified**

**100% Factory Pressure and Run Tested**

**Equipped with Surge Arrestor**

**Automatic Thermal Protection on 1/2 – 1 HP Models**

# Pentek® XE Series™ Motors

Stainless Steel

## ORDERING INFORMATION

RATING					CATALOG NUMBER	FULL LOAD AMPS	MAX. LOAD (SF LOAD) AMPS	LOCKED ROTOR AMPS	WINDING		THRUST RATING	LENGTH		WEIGHT	
HP	kW	VOLTS	Hz	SERVICE FACTOR					MAIN RESISTANCE	START RESISTANCE		IN.	MM	LB.	KG
<b>PERMANENT SPLIT CAPACITOR (PSC) 2 WIRE</b>															
1/2	0.37	115	60	1.6	P42B0005A1	8.1	10.2	28.0	1.4-2.0	700	11.0	279	19.2	8.7	
		230			P42B0005A2	4.3	4.8	16.0	6.1-7.2		11.0	279	19.2	8.7	
3/4	0.55	230	60	1.5	P42B0007A2	5.0	6.4	18.0	5.9-6.9	700	12.4	314	22.7	10.3	
1	0.75	230			P42B0010A2	6.7	8.2	23.5	4.2-5.2		13.0	337	24.5	11.1	
1-1/2	1.1	230			P42B0015A2	9.1	10.5	43.0	1.8-2.4		14.9	378	28.9	13.1	

## CAPACITOR START/INDUCTION RUN (CSIR) 3 WIRE

1/2	0.37	115	60	1.6	P43B0005A1	9.8	11.6	44.0	1.0-1.4	2.5-3.1	700	10.0	253	18.9	8.6
		230			P43B0005A2	5.7	6.3	20.5	5.1-6.1	12.4-13.7		9.7	246	18.1	8.2
3/4	0.55	230	60	1.5	P43B0007A2	6.7	7.9	32.0	2.6-3.3	10.4-11.7	700	10.8	275	21.4	9.7
1	0.75	230			P43B0010A2	8.5	9.5	41.0	2.0-2.6	9.3-10.4		11.7	297	23.1	10.5

## CAPACITOR START/CAPACITOR RUN (CSCR) 3 WIRE

1/2	0.37	230	60	1.6	P43B0005A2	4.4	5.0	21.0	5.1-6.1	12.4-13.7	700	9.7	246	18.1	8.2	
3/4	0.55			1.5	P43B0007A2	4.6	6.1	32.0	2.6-3.3	10.4-11.7		10.8	275	21.4	9.7	
1	0.75			1.4	P43B0010A2	6.2	7.4	41.0	2.0-2.6	9.3-10.4		11.7	297	23.1	10.5	
1-1/2	1.1			1.3	P43B0015A2	9.2	11.0	49.0	2.1-2.5	10.0-10.8		13.6	345	27.4	12.4	
2	1.5			900	1.25	P43B0020A2	9.9	12.2	49.0	1.6-2.2	4.8-5.9	15.1	383	31.0	14.1	
3	2.2				1.15	P43B0030A2	14.3	16.5	76.0	1.0-1.4	2.0-2.5	18.3	466	40.0	18.1	
5	3.7				1.15	P43B0050A2	24.0	27.0	101.0	.6-.8	1.3-1.7	1500	27.7	703	70.0	31.8

## 3 PHASE

RATING					CATALOG NUMBER	FULL LOAD AMPS	MAX. LOAD (SF LOAD) AMPS	LINE TO LINE RESISTANCE OHMS	LOCKED ROTOR AMPS	THRUST RATING	LENGTH		WEIGHT	
HP	kW	VOLTS	Hz	SERVICE FACTOR							IN.	MM	LB.	KG
1/2	0.37	200	60	1.6	P43B0005A8	2.9	3.5	4.1-5.2	22	700	10.0	254	18.9	8.6
		230			P43B0005A3	2.4	3.0	5.7-7.2	18		10.0	254	18.9	8.6
		460			P43B0005A4	1.3	1.5	23.6-26.1	9		10.0	254	18.9	8.6
3/4	0.55	200	60	1.5	P43B0007A8	3.9	4.7	2.8-3.7	30		10.8	274	21.4	9.7
		230			P43B0007A3	3.3	4.0	3.3-4.3	27		10.8	274	21.4	9.7
		460			P43B0007A4	1.7	2.0	14.4-16.2	14		10.8	274	21.4	9.7
1	0.75	200	60	1.4	P43B0010A8	4.8	5.7	2.2-3.1	34		11.7	297	23.1	10.5
		230			P43B0010A3	4.1	4.9	3.2-4.2	26		11.7	297	23.1	10.5
		460			P43B0010A4	2.2	2.5	16.8-18.6	15		11.7	297	23.1	10.5
1-1/2	1.1	200	60	1.3	P43B0015A8	6.6	7.6	1.9-2.5	40		11.7	297	23.1	10.5
		230			P43B0015A3	5.8	6.6	2.5-3.1	36		11.7	297	23.1	10.5
		460			P43B0015A4	3.0	3.4	9.5-10.5	16		11.7	297	23.1	10.5
		575			P43B0015A5	2.3	2.6	15.6-17.3	15	11.7	297	23.1	10.5	
		200			P43B0020A8	8.0	9.3	1.4-2.0	51	13.8	351	27.4	12.4	
2	1.5	230	60	1.25	P43B0020A3	6.7	8.0	2.2-2.8	44	13.8	351	27.4	12.4	
		460			P43B0020A4	3.6	4.1	7.5-9.3	23	13.8	351	27.4	12.4	
		575			P43B0020A5	2.7	3.3	10.2-12.5	21	15.3	389	32.0	14.5	
		200			P43B0030A8	10.9	12.0	1.2-1.5	71	15.3	389	32.0	14.5	
3	2.2	230	60	1.15	P43B0030A3	9.2	10.1	1.6-2.0	59	15.3	389	32.0	14.5	
		460			P43B0030A4	4.8	5.3	6.3-7.7	30	15.3	389	32.0	14.5	
		575			P43B0030A5	3.7	4.1	10.2-12.5	21	15.3	389	32.0	14.5	
		200			P43B0050A8	18.3	20.2	.7-.9	113	21.7	551	55.0	24.9	
5	3.7	230	60	1.15	P43B0050A3	15.7	17.5	.9-1.3	93	21.7	551	55.0	24.9	
		460			P43B0050A4	7.6	8.5	3.9-4.9	48	21.7	551	55.0	24.9	
		575			P43B0050A5	7.0	7.6	3.6-4.2	55	27.7	703	70.0	31.8	
		200			P43B0075A8	27.0	30.0	.4-.6	165	27.7	703	70.0	31.8	
7-1/2	5.6	230	60	1.15	P43B0075A3	24.0	26.4	5-.9	140	27.7	703	70.0	31.8	
		460			P43B0075A4	12.2	13.5	2.1-2.7	87	27.7	703	70.0	31.8	
		575			P43B0075A5	9.1	10	3.6-4.2	55	27.7	703	70.0	31.8	
10	7.5	460	60	1.15	P43B0100A4	15.6	17.2	1.8-2.2	110	30.7	780	78.0	35.4	

NOTE: Amp ratings on 3-wire motors reflect use with CSIR controls. A CSCR control is recommended for lower values.

# Pentek® XE Series™ Motors

Stainless Steel

## OUTLINE DIMENSIONS

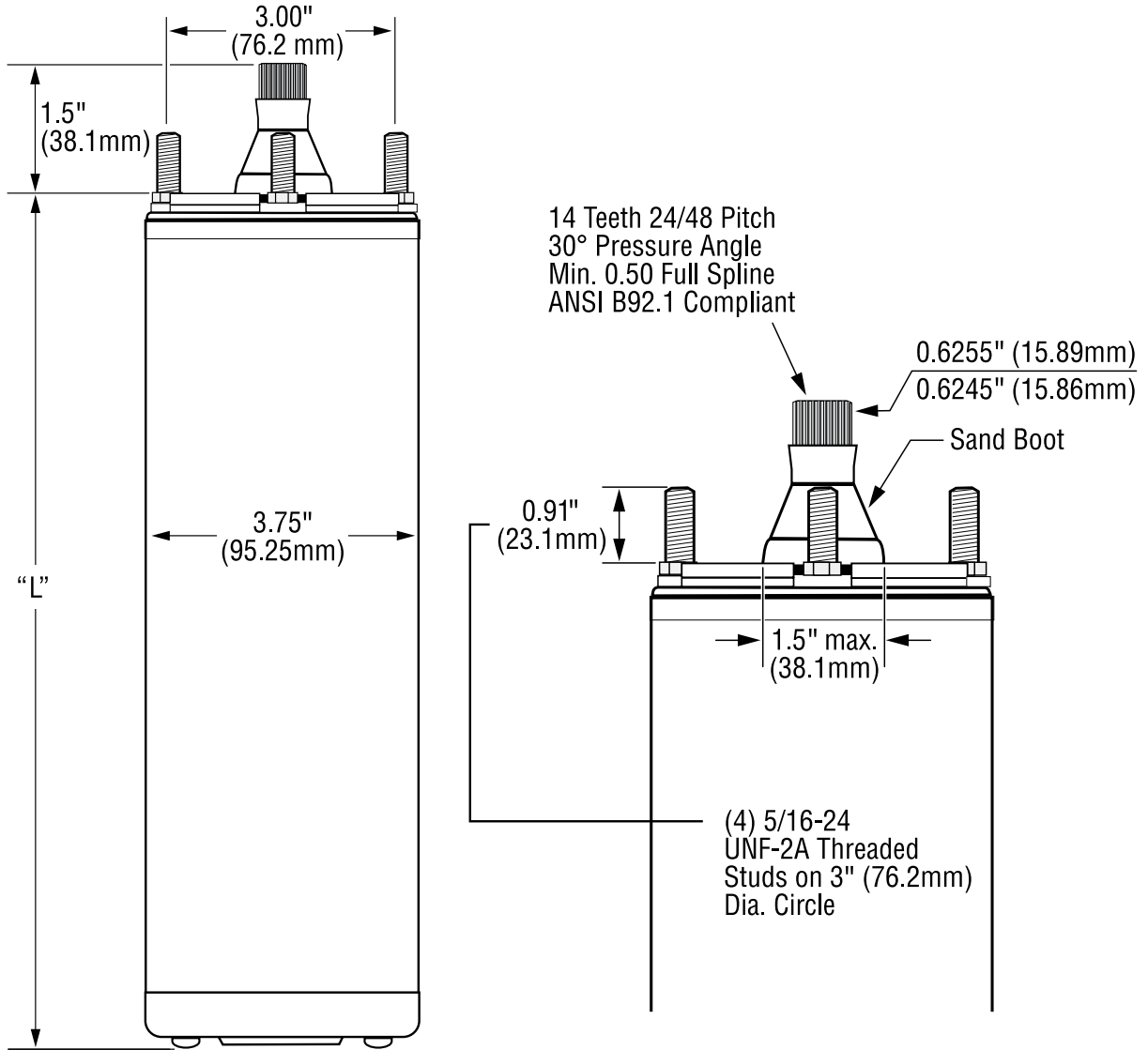

Dimensions (in inches) are for estimating purposes only.

### LEAD LENGTH

CATALOG NUMBER	# OF WIRES	TYPE	LENGTH	GAUGE
<b>XE SERIES REPLACEMENT MOTOR LEADS</b>				
P18-1485K	2 Wire	XLPE	48"	14 Ga
P18-1486K	3 Wire	XLPE	48"	14 Ga
P18-1486K	3 Wire	XLPE	48"	14 Ga
P18-1486K	3 Wire	XLPE	48"	14 Ga

# Submersible Motor Controls



Pentek® offers a full range of 1/2 - 5 HP models that are interchangeable with existing motor controls for Capacitor Start/Induction Run (CSIR) and Capacitor Start/Capacitor Run (CSCR) applications. Pentek is the professional choice in harsh and high temperature installations.

## APPLICATIONS

**Water systems...**for residential, commercial, multiple housing and farm uses, where a submersible 3-wire motor is used.

## FEATURES

### ENCLOSURE

**Rugged NEMA 3R Enclosure:**  
Suitable for indoor/outdoor use.

**NEW HardBond™ Finish:**  
5-times more corrosion-resistant.

**Multiple-Size Electrical Knockouts**

### INTERNALS

**High-Load Voltage Relay**

**Heavy-Duty Contacts**

**External Access to Overload Reset CSCR**

**Heavy-Duty Terminal Connectors:**  
Suitable for up to #4 AWG wire.

**Industry Standard Wiring Connections:**  
Easy-to-read wiring diagrams.

**Agency Approvals:** UL 778 and CUL Recognized (60 Hz)



# Submersible Motor Controls

## ORDERING INFORMATION

HP	KW	PH	VOLTS	60 HZ CATALOG NUMBER	WEIGHT		ENCLOSURE SIZE
					LBS.	KG	
<b>CSIR – CAPACITOR START/INDUCTION RUN</b>							
1/2	0.37	1	115	SMC-IR0511 [-6pk]*	4	1.8	A
1/2	0.37	1	230	SMC-IR0521 [-6pk]*	4	1.8	A
3/4	0.55	1	230	SMC-IR0721 [-6pk]*	4	1.8	A
1	0.75	1	230	SMC-IR1021 [-6pk]*	4	1.8	A
<b>CSCR – CAPACITOR START/CAPACITOR RUN</b>							
1/2	0.37	1	230	SMC-CR0521 [-6pk]*	5	2.3	A
3/4	0.55	1	230	SMC-CR0721 [-6pk]*	5	2.3	A
1	0.75	1	230	SMC-CR1021 [-6pk]*	5	2.3	A
1-1/2	1.1	1	230	SMC-CR1521	7	3.2	B
2	1.5	1	230	SMC-CR2021	7	3.2	B
3	2.2	1	230	SMC-CR3021	7	3.2	B
5	3.7	1	230	SMC-CR5021	8	3.6	B
<b>CSCR PLUS – CAPACITOR START/CAPACITOR RUN PLUS MAGNETIC CONTACTOR</b>							
2	1.5	1	230	SMC-CRP2021	7	3.2	B
3	2.2	1	230	SMC-CRP3021	8	3.6	B
5	3.7	1	230	SMC-CRP5021	12	5.4	C

\*Submersible Motor Controls are available in single and six packs. Include the suffix “-6pk” after the catalog number if 6 packs are required.

## OUTLINE DIMENSIONS

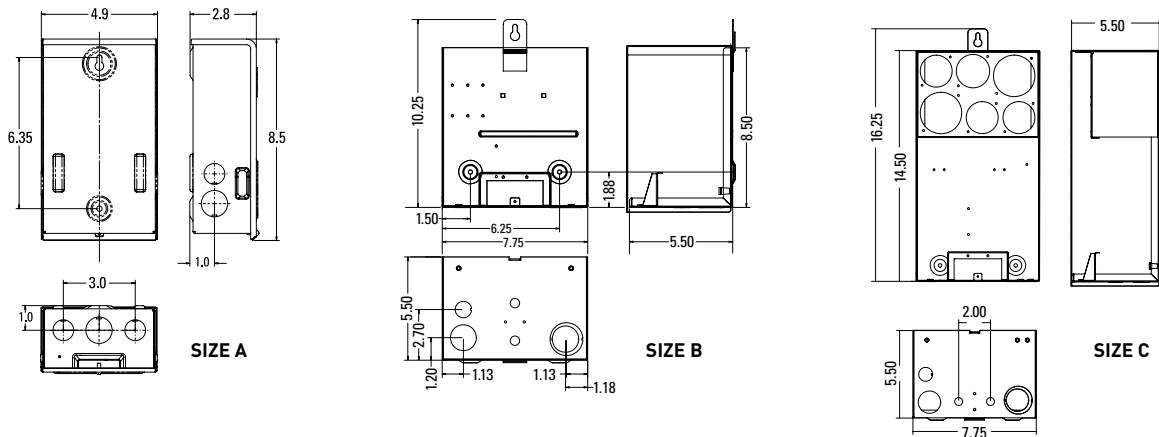

Dimensions (in inches) are for estimating purposes only.

# Pentek® VIP Pro Series Controls



**Capacitor start, capacitor run — designed for the full range of single-phase 1/2, 3/4, 1, 1-1/2, 2, 3 and 5 HP, 3-wire submersible motors**

## APPLICATIONS

**Water systems...**for residential, multiple housing, farm and commercial installations, where a submersible 3-wire motor is used.

## FEATURES

### ENCLOSURE

- 1 Weather resistant construction – NEMA 3R/IP24 rated enclosure for indoor/outdoor use
- 2 Control box rated for 50°C (122°F) ambient temperature
- 3 One screw removal for easy panel access with motor running
- 4 Pentek® proprietary dielectric control panel board, UL and CSA Certified

### INTERNALS

- 5 Universal controls -designed to work on most manufacturers 3-wire submersible motors
- 6 Large wiring area offers generous space to make your wiring connections. Incorporates 1/2", 3/4" and 1" conduit knock-outs
- 7 Control box is functional with the cover removed, offering easier in-the-field troubleshooting

**Agency Approvals:** CSA CUS Certified Pentek Submersible Motor Controls can be used with Pentek XE Series motors.



# Pentek® VIP Pro Series Controls

## SIZE A

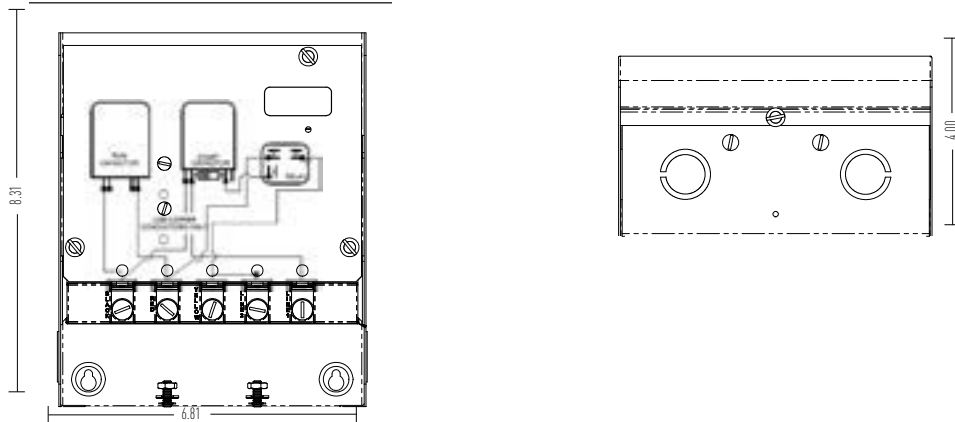

## SIZE B

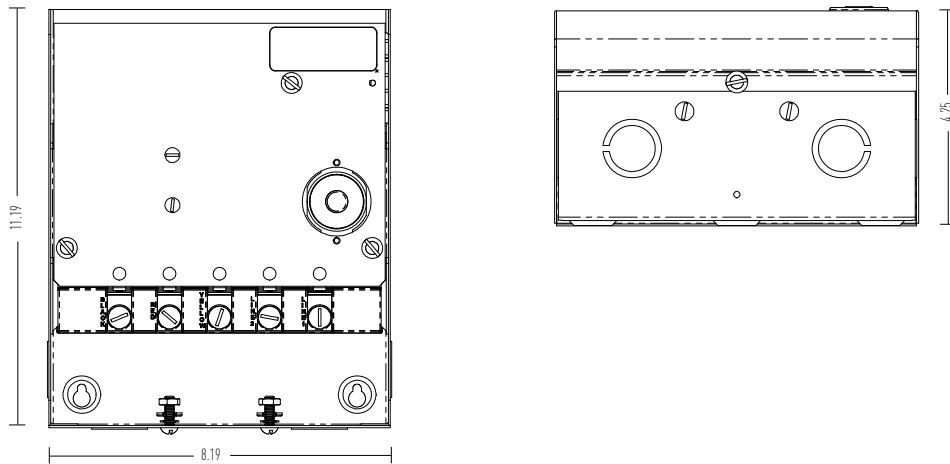

## VIP CONTROL BOX SPECIFICATION

CATALOG NUMBER	HP	KW	PHASE	VOLTS	HERTZ	TYPE	WEIGHT		ENCLOSURE SIZE	START CAPACITOR		RUN CAPACITOR		VOLTAGE RELAY	PROTECTOR
							LBS	KG		PN	RATING	PN	RATING		
VIP4C02	0.50	0.37	1	230	60	CSCR	4.6	2.1	A	U17-1422	43MFD-270V-15kΩ	U17-2072	15MFD-370V	U17-2077	None
VIP4D02	0.75	0.55	1	230	60	CSCR	4.4	2.0	A	U17-1423	59MFD-270V-15kΩ	U17-2073	20MFD-370V	U17-2077	None
VIP4E02	1.00	0.75	1	230	60	CSCR	4.4	2.0	A	U17-1424	86MFD-270V-15kΩ	U17-2074	23MFD-370V	U17-2077	None
VIP4F02	1.50	1.1	1	230	60	CSCR	4.6	2.1	A	U17-1430	105MFD-330V-15kΩ	U17-1438	10MFD-370V	U17-2078	CGP69JB-7
VIP4G02	2.00	1.5	1	230	60	CSCR	4.6	2.1	A	U17-1430	105MFD-330V-15kΩ	U17-1440	23MFD-370V	U17-1431	CET38EB-7
VIP4H02	3.00	2.2	1	230	60	CSCR	5.4	2.4	A	U17-1428	208MFD-330V-15kΩ	U17-1443	45MFD-370V	U17-1431	CGT66DD-07
VIP4J02	5.00	3.7	1	230	60	CSCR	8.2	3.7	B	U17-1437	270MFD-330V-15kΩ	U17-1442	40MFD-370V (2 pcs)	U17-2079	BET00EE-21

Control boxes are designed to be used on Pentair motors with the same HP and Voltage ratings. Do not use on motors with different ratings.

# Submersible Motor Controls



Pentek® offers a full range of 1/3 - 15 HP single-phase protectors for residential, commercial, multiple housing and farm water systems applications where a 4" submersible, 2- and 3-wire motor is used and for aboveground pressure-boost applications.

## APPLICATIONS

Pentek offers 5 models for your application needs based on HP and Motor Type: SPP-111P, SPP-111-3RLP, SPP-231P, SPP-233P and SPP-235P.

## FEATURES

**Protects Pumps:** From dry well, overcurrent (jammed impeller), flow restriction (dead head), overvoltage, undervoltage, rapid cycling.

## ORDERING INFORMATION

	115 VOLT MODELS		230 VOLT MODELS		
<b>Catalog Number</b>	SPP-111P	SPP-111-3RLP	SPP-231P	SPP-233P	SPP-235P
<b>Enclosure Type</b>	Insider	NEMA 3R	Insider	NEMA 3R	NEMA 3R
<b>1-Phase Line Voltage</b>	115VAC	115VAC	230VAC	230VAC	230VAC
<b>Load Range</b>	1/3-1/2 HP	1/3-1 HP	1/2-1 HP	1/2-3 HP	5-15 HP
<b>Frequency</b>	50-60Hz	50-60Hz	50-60Hz	50-60Hz	50-60Hz
<b>Operating Points</b>					
Overload (% of Cal. Point)	125%	125%	125%	125%	125%
Overvoltage Reset Point	132VAC	132VAC	265VAC	265VAC	265VAC
Undervoltage Reset Point	95VAC	95VAC	190VAC	190VAC	190VAC
Trip Delay (Overload)	10 sec.	10 sec.	10 sec.	5 sec.	5 sec.
Trip Delay (Dry Well)	2 sec.	2 sec.	2 sec.	2 sec.	2 sec.
Optional Trip Delay	4 sec.	4 sec.	4 sec.	4 sec.	4 sec.
<b>Restart Delay Time</b>					
Over/Under Voltage Delay	5 sec.	5 sec.	5 sec.	5 sec.	5 sec.
All Other Faults (Dry Well REC. Timer)	2-225 min.	2-225 min.	2-225 min.	2-225 min.	2-225 min.
<b>Output Contact Rating (SPST)</b>	1 HP	1 HP	1 HP (17 amps max.)	3 HP (17 amps max.)	480VA @ 240VAC
<b>Power Consumption (max.)</b>	5 amps	5 amps	5 amps	5 amps	5 amps
<b>Weight w/o Enclosure</b>	10 oz.		10 oz.	14 oz.	14 oz.
<b>Weight w/Enclosure</b>		1.6 lbs.		1.6 lbs.	1.6 lbs.
<b>Enclosure Size</b>	2.2" x 2.8"	6" x 6" x 4"	2.2" x 2.8"	6" x 6" x 4"	6" x 6" x 4"

# SPP-111P and SPP-231P

The Insider



## APPLICATIONS

**Water systems...**for residential, commercial, multiple housing, farm and turf irrigation uses, where a 4" submersible 3-wire motor is used.

## FEATURES

**Restart Delay:** Can be set up to 225 minutes or placed in manual reset mode.

**Calibration:** Can be calibrated to specific pump/motor combinations and various conditions.

**Infrared Communication:** Coupled with the Pentek Informer makes diagnostics simple.

**Fits in Existing 3-Wire Motor Control Boxes**

For 1/3 - 1 HP applications, the SPP-111P and the SPP-231P Insider fits within 1/3 - 1 HP 115V and 230V CSIR control boxes. It's a "current monitor" designed to protect single-phase pumps. A simple adjustment allows the Insider to be calibrated to your specific pumping applications, reducing the possibility of false or nuisance tripping. Its unique microprocessor constantly monitors the incoming power

for fluctuations in voltage and current. If loss of suction or other abnormality is detected, the Insider deactivates its output relay and directly disconnects the pump motor. Then it begins its user-selectable "Restart Delay/Dry Well Recovery" timer. When the timer counts zero or power is removed and reapplied, the SPP-231P Insider reactivates its output relay and turns the pump back on.

The Pentek® Informer Remote Handheld Diagnostic Tool (sold separately) communicates directly with ALL Pentek Pump Protectors and instantly displays 16 parameters including calibration points, running points and last fault.

## ORDERING INFORMATION

HP	PHASE	VOLTS	FREQUENCY	CATALOG NUMBER	WEIGHT		CARTON SIZE
					LBS.	KG	
1/3-1/2	1	115	50-60Hz	SPP-111P	1	0.45	4.4" x 4.4" x 6.8"
1/3-1	1	230	50-60Hz	SPP-231P	1	0.45	4.4" x 4.4" x 6.8"

# SPP-111-3RLP, SPP-233P and SPP-235P



SPP-233P



For 1/2 - 15 HP applications the SPP-111-3RLP, SPP-233P and SPP-235P single-phase protectors include a unique microcontroller-based voltage and current-sensing circuit that constantly monitors the incoming power for fluctuations including overcurrent and undercurrent. When an abnormality, such as loss of suction, is detected, the control deactivates its output relay and directly disconnects the pump motor.

The SPP then begins its user-selectable restart delay (dry-well recovery) timer. When the timer counts to zero or power is removed and reapplied, the SPP reactivates its output relay and turns the pump back on. An infrared LED communicates directly with a handheld diagnostic tool called the Informer (sold separately – see page 60). The Informer displays 15 parameters including calibration point, trip point, running points, and last fault. The SPPs are all mounted in a NEMA 3R enclosure.

## APPLICATIONS

**Water systems...**for residential, commercial, multiple housing and farm uses, where a 4" 2 or 3-wire submersible motor or aboveground motor is used.

## FEATURES

**Protects Pumps:** From dry well overvoltage, flow restriction (dead head), undervoltage, overcurrent (jammed impeller).

## ORDERING INFORMATION

HP	PHASE	VOLTS	FREQUENCY	CATALOG NUMBER	WEIGHT		CARTON SIZE
					LBS.	KG	
1/2-1	1	115	50-60Hz	SPP-111-3RLP	1.6	0.7	7.25" x 7" x 5.25"
1/2-1-1/2	1	230	50-60Hz	SPP-233P-1.5	1.6	0.7	7.25" x 7" x 5.25"
1/2-3	1	230	50-60Hz	SPP-233P	1.6	0.7	7.25" x 7" x 5.25"
5 and 7-1/2	1	230	50-60Hz	SPP-235P-75*	2	0.9	7.25" x 7" x 5.25"
10	1	230	50-60Hz	SPP-235P-100*	2	0.9	7.25" x 7" x 5.25"
15	1	230	50-60Hz	SPP-235P-150*	2	0.9	7.25" x 7" x 5.25"

\*Current transformer included.

# The Informer

Remote diagnostic



## FEATURES

**Infrared Receiver:** The Pentek® Informer uses an infrared receiver to access data sent from the SPP, allowing remote troubleshooting of the system.

**Infrared LED:** Each Pentek SPP is equipped with an infrared LED that transmits information from the device. The Informer must be aimed at the SPP as shown in the figure to the left. As soon as power is applied, the Informer begins receiving both past and present information and displays it on the LCD.

**Status Light:** The green COMM STATUS light indicates when the Informer is receiving data from the SPP. If communication is lost, the Informer will hold the last values it received.

## APPLICATIONS

The Pentek® Informer...a remote handheld diagnostic tool designed for use with Pentek single-phase submersible pump protectors (SPP-111P, 231P, 233P and 235P) equipped with infrared LED transmitters.

## SPECIFICATIONS

**Displayed Parameters:** Diagnostic information received and displayed in real time: Voltage, Current, Power, Dry Well.

**Overload Trip Points**

**Calibration Voltage**

**Last Fault**

**Highest/Lowest Voltage Since Last Calibration**

## ORDERING INFORMATION

CATALOG NUMBER	WEIGHT		CARTON SIZE
	LBS.	KG	
SPP-Informer	1	0.45	4.375" x 3.375" x 6.75"

# Pentek Intellidrive™

## Water Pressure Control Center



**Homeowners with water pressure problems experience weak showers, unclean dishes, dry lawns and more.** The Pentek Intellidrive Water Pressure Control Center is an “Intelligent Variable Frequency Drive” that directs changes in submersible pump motor speed, responding to fluctuations in household demand. It maintains constant water pressure, regardless of how many people or appliances are using water at the same time.

### APPLICATIONS

Residential water systems, landscape irrigation, water transfer.

### SPECIFICATIONS

**Enclosure Dimensions:**

Width: 9.72” Height: 19” Depth: 6.93”

**Carton Dimensions:**

Width: 10.4” Height: 22.3” Depth: 9.4”

**Shipping Weight:** 22 pounds

**Ambient Temperature Range:**

-20°C (-4°F) to 50°C (122°F)

**Ambient Humidity Range:**

95% non-condensing

**Includes:**

Variable Frequency Drive

**Transducer:** 1/4” thread size, 18 NPT type

**Transducer Cable:** 10’ length standard

### FEATURES

**4 MODELS MEET ALL YOUR NEEDS**

1/2 HP - 5 HP Capabilities

2-Wire, 3-Wire & 3-Phase in same unit

3-Phase Output (60 Hz/80 Hz)\*\*

**PUMP AND MOTOR LAST LONGER**

“Soft Start/Coast to Stop” minimizes mechanical stress.

Constant pressure eliminates frequent on/off “pressure cycling”.

**ADVANCED CONTROL SYSTEM**

Needed for installation, system monitoring and troubleshooting.

Easy touchpad operation.

**GROUND DETECTION**

Detects and displays when there is a grounding problem.

Shuts down system until problem is corrected.

60Hz operation is recommended as the industry standard. Intermittent 80Hz operation is an acceptable option. \*\* Ongoing 80Hz operation may reduce the life of the pump and motor.

### ORDERING INFORMATION

MODEL NUMBER	MOTOR TYPE	HP RANGE	INPUT VOLTAGE	MAXIMUM OUTPUT AMPS	ENCLOSURE TYPE
PID10	2-WIRE* 1-PHASE	0.5 – 1 HP	190V – 265V	9.5A	NEMA 3R outdoor
	3-WIRE* 1-PHASE			7.5A	
	3-PHASE			5A	
PID20	2-WIRE* 1-PHASE	0.5 – 1.5 HP		11A	
	3-WIRE* 1-PHASE	0.5 – 2 HP		13.5A	
	3-PHASE			8.5A	
PID30	2-WIRE* 1-PHASE	0.5 – 1.5 HP		11A	
	3-WIRE* 1-PHASE	0.5 – 2 HP		13.5A	
	3-PHASE	0.5 – 3 HP		11.5A	
PID50	2-WIRE* 1-PHASE	0.5 – 1.5 HP		11A	
	3-WIRE* 1-PHASE	0.5 – 2 HP		13.5A	
	3-PHASE	0.5 – 5 HP		18A	

# Pentek Intellidrive™

## Water Pressure Control Center

### Keyhole Mount

For fast and easy installation

### LCD Information Center

Displays installation, status and fault information in easy-to-understand language instead of codes

### Ground Detection

Message Center shows if there is a grounding problem

### Multiple Accessory Inputs

Additional inputs allow use of multiple drive accessories at the same time

### Best-In-Class EMI/RFI Filter

Superior noise and interference protection, including AM radio signals

### Spacious Wiring Area

For fast and easy installation

### Programmable Input/Output Relays

Provide application flexibility

### Easy-Access Conduit Openings

Align with appropriate terminals for straight-in accessibility. Fits 1/2", 3/4" or 1-1/4"

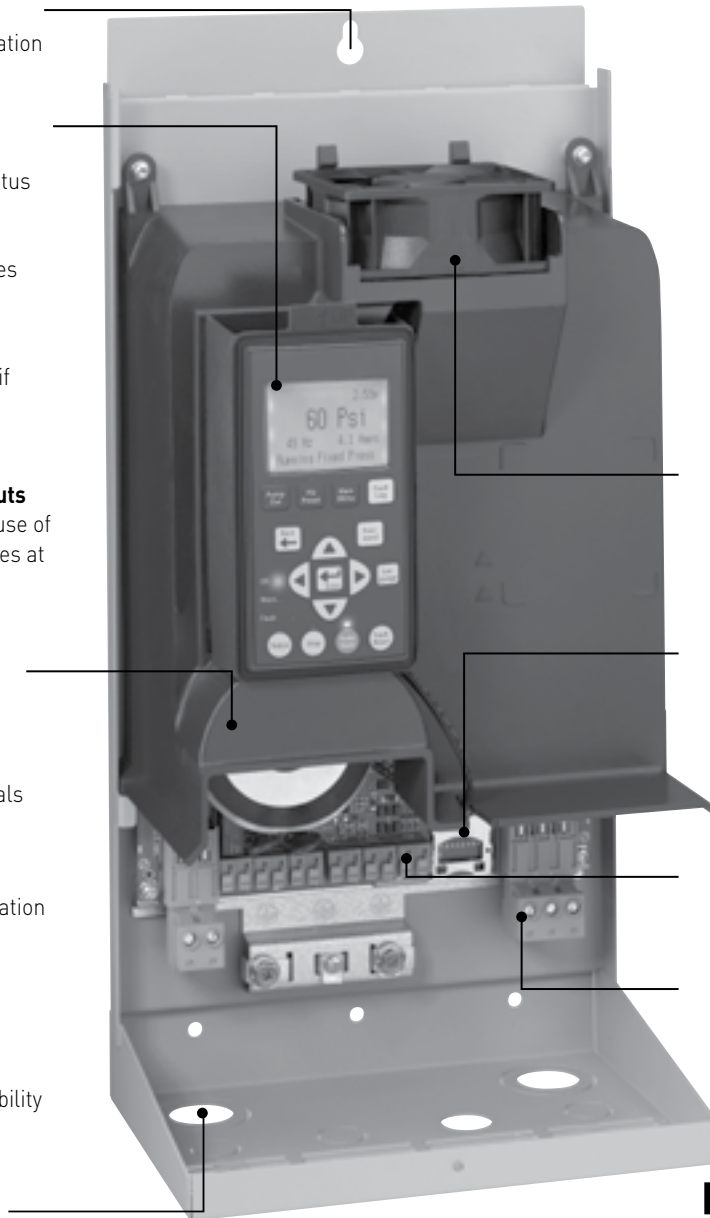

### Electronic Pressure Transducer

More accurate and reliable than mechanical pressure switch, with piezo resistive technology designed to resist water hammer

### Temperature-Sensitive Intelligent Fan

Operates when needed for quiet operation

### SD Card Slot

For easy software updates when provided by manufacturer

### Spring Terminals

For secure connections and easy installation without special tools

### Removable Terminal Blocks

For easy wiring of motor and power supply – field replaceable

### OUTLINE DIMENSIONS

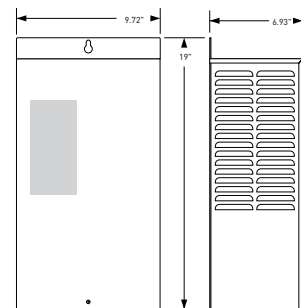

Dimensions (in inches) are for estimating purposes only.

# Pentek Intellidrive™

## Water Pressure Control Center

### PENTEK INTELLIDRIVE ACCESSORIES

MODEL NO.	DESCRIPTION
VFD-LINK	Wireless Translator for Intellidrive
VFD-SGA	Surge arrestor kit, line and load
VFD-SGA-LN	Surge arrestor kit, line side
VFD-SGA-LD	Surge arrestor kit, load side
VFD-ALT	VFD Alternating panel
VFD-WS	VFD Water sensor with 15' cable
PID-GRP	Cable mounting and nut, 1/2 NPT, black, qty. 10
VFD-SCRN	Filter Kit



**VFD-WS**  
VFD WATER SENSOR WITH 15' CABLE

### PENTEK INTELLIDRIVE TRANSDUCER CABLES

PART NUMBER	DESCRIPTION	REPLACES
VFD-10TCB	Transducer Cable 10FT 3R	U18-1593
VFD-20TCB	Transducer Cable 20FT 3R	U18-1594
VFD-50TCB	Transducer Cable 50FT 3R	U18-1595
VFD-100TCB	Transducer Cable 100FT 3R	U18-1596
VFD-200TCB	Transducer Cable 200FT 3R	U18-1598



**VFD-ALT**  
VFD ALTERNATING PANEL

### PENTEK INTELLIDRIVE REPAIR PARTS

MODEL NO.	ITEM	DESCRIPTION	MANUFACTURER
PID-CON2	2-Pole Connector (Line In)	2-Pole Connector (Line In)	Pentek®
PID-CON3	3-Pole Connector (Line Out)	3-Pole Connector (Line Out)	Pentek
PID-FAN	Replacement Fan	Replacement Fan	Pentek
PID-HMI	Replacement Keypad	Replacement Keypad	Pentek
U17-1561-R	Transducer (PID Control)	0 – 100 psig, 4~20ma, less lead	Pentek

Pentek Transducer for use with Pentek Intellidrive and Intellidrive XL.



**VFD-LINK**  
WIRELESS TRANSLATOR FOR INTELLIDRIVE

# Pentek Intellikit™

## Constant Pressure Controller

### Pre-Specified and Packaged Constant Pressure Systems for Residential Well Water

Maintain constant water pressure for submersible well pump systems, similar to municipal water systems



#### KIT CONTAINS:

- Pentek® Submersible Motor
- Sta-Rite® Submersible Pump
- Pentek Intellidrive™ Variable Frequency Drive

The Pentek Intellidrive Constant Pressure Controller automatically adjusts motor speeds to meet changes in water demand. Instantaneous feedback from an electronic pressure transducer instructs the drive to change the submersible well pump motor speed to maintain constant pressure throughout the system.

#### 1 PENTEK

##### Submersible 3-Phase Motor

Built with the latest design, manufacturing and testing technology

Encapsulated stainless steel design and professional-grade insulation provide longer life in harsh environments

100% factory pressure- and run-tested

#### 2 STA-RITE

##### Submersible Pump

Submersible pumps deliver efficient and dependable performance even in rough, aggressive water

One of the few manufacturers of both pumps and pressurized water storage tanks, now sold in over 100 countries

#### 3 PENTEK INTELLIDRIVE

##### Variable Frequency Drive

Maintains constant pressure output regardless of fluctuating demand

Extends life of pump and motor

Utilizes a smaller pressure tank for a space-saving solution

# Pentek Intellikit™

## Constant Pressure Controller

### ORDERING INFORMATION

#### 60Hz NEMA 3 Kits

Order Number	Flow Series	HP	Shut-Off Head	At Rated Flow	at Max Runout		Pump	Drive	Motor
			TDH (ft)	TDH (ft)	Flow (GPM)	TDH (ft)			
S5PIK10-60	5	1HP	650	475	7	300	L5P4EHL	PID10	P43B0010A3-C
S5PIK15-60	5	1.5HP	885	640	7	400	L5P4FHL	PID20	P43B0015A3-C
S7PIK10-60	7	1HP	540	380	10	140	L7P4EHL	PID10	P43B0010A3-C
S7PIK15-60	7	1.5HP	740	475	10	190	L7P4FHL	PID20	P43B0015A3-C
S7PIK20-60	7	2HP	920	610	10	210	L7P4GHL	PID20	P43B0020A3-C
S10PIK10-60	10	1HP	495	300	15	110	L10P4EH	PID10	P43B0010A3-C
S10PIK15-60	10	1.5HP	629	410	15	150	L10P4FH	PID20	P43B0015A3-C
S10PIK20-60	10	2HP	795	498	15	200	L10P4GH	PID20	P43B0020A3-C
S10PIK30-60	10	3HP	1100	710	15	250	L10P4HH	PID30	P43B0030A3-C
S15PIK10-60	15	1HP	310	200	21	95	L15P4EH	PID10	P43B0010A3-C
S15PIK15-60	15	1.5HP	420	280	21	120	L15P4FH	PID20	P43B0015A3-C
S15PIK20-60	15	2.0HP	522	350	21	150	L15P4GH	PID20	P43B0020A3-C
S15PIK30-60	15	3.0HP	770	520	21	230	L15P4HH	PID30	P43B0030A3-C
S20PIK10-60	20	1HP	250	185	28	80	L20P4EH	PID10	P43B0010A3-C
S20PIK15-60	20	1.5HP	335	232	28	110	L20P4FH	PID20	P43B0015A3-C
S20PIK20-60	20	2.0HP	420	310	28	150	L20P4GH	PID20	P43B0020A3-C
S20PIK30-60	20	3.0HP	640	460	28	200	L20P4HH	PID30	P43B0030A3-C
S30PIK20-60	30	2.0HP	275	195	42	85	L30P4GH	PID20	P43B0020A3-C
S30PIK30-60	30	3.0HP	410	295	42	120	L30P4HH	PID30	P43B0030A3-C
S50PIK20-60	50	2.0HP	180	119	63	80	L50P4GH	PID20	P43B0020A3-C
S50PIK30-60	50	3.0HP	240	162	63	110	L50P4HH	PID30	P43B0030A3-C
S90PIK20-60	90	2.0HP	109	58	120	40	L90HF20	PID20	P43B0020A3-C
S90PIK30-60	90	3.0HP	150	80	120	55	L90HF30	PID30	P43B0030A3-C

#### 80Hz NEMA 3 Kits

S7PIK15-80	7	1.5HP	740	475	10	190	L7P4DHL	PID20	P43B0015A3-C
S7PIK20-80	7	2HP	920	610	10	210	L7P4EHL	PID20	P43B0020A3-C
S7PIK30-80	7	3HP	1205	805	10	290	L7P4FHL	PID30	P43B0030A3-C
S10PIK15-80	10	1.5HP	629	410	15	150	L10P4DH	PID20	P43B0015A3-C
S10PIK20-80	10	2HP	795	498	15	200	L10P4EH	PID20	P43B0020A3-C
S10PIK30-80	10	3HP	1100	710	15	250	L10P4FH	PID30	P43B0030A3-C
S15PIK15-80	15	1.5HP	420	280	21	120	L15P4DH	PID20	P43B0015A3-C
S15PIK20-80	15	2.0HP	522	350	21	150	L15P4EH	PID20	P43B0020A3-C
S15PIK30-80	15	3.0HP	770	520	21	230	L15P4FH	PID30	P43B0030A3-C
S20PIK15-80	20	1.5HP	335	232	28	110	L20P4DH	PID20	P43B0015A3-C
S20PIK20-80	20	2.0HP	420	310	28	150	L20P4EH	PID20	P43B0020A3-C
S20PIK30-80	20	3.0HP	640	460	28	200	L20P4FH	PID30	P43B0030A3-C
S30PIK20-80	30	2.0HP	275	195	42	85	L30P4EH	PID20	P43B0020A3-C
S30PIK30-80	30	3.0HP	410	295	42	120	L30P4FH	PID30	P43B0030A3-C
S50PIK30-80	50	3.0HP	240	162	63	110	L50P4FH	PID30	P43B0030A3-C
S90PIK30-80	90	3.0HP	150	80	120	55	L90HF20	PID30	P43B0030A3-C

**Note:**

80Hz Kits utilize an undersized liquid end running at higher speed to match pump performance of the curve equivalent to the driving motor. Maximum life expectancy of the liquid end is obtained using 60Hz solutions.

# Pentek Intellidrive™ XL Pump Controllers



Pentek Intellidrive XL, the latest addition to our line of variable frequency drives, is designed for large horsepower pumping applications. Selection is easy. Setup is simple. And you have powerful opportunities to customize as needs arise. All backed by expert, dedicated tech support, available to quickly and efficiently resolve any issues.

## APPLICATIONS

Turf irrigation, water transfer, light commercial water systems and agricultural.

## SPECIFICATIONS

**HP Ratings:** 1-150

**Voltage:** 230, 460, 575

**Frequency:** 50/60 Hz

**Standard I/O:** Digital Inputs: 6; Analog Inputs: 2; Pulse Inputs: 2; Relays: 2; Digital Outputs: 2; Analog Outputs: 4

**Communication:** Modbus RTU

**Enclosure Type:** NEMA 1, 3R, 4X, IP20 Open/Chassis

## FEATURES

### Pentek Intellidrive XL:

**Variable Speed Control:** Meets requirements of process control with constant pressure at variable flow conditions or constant flow at variable pressure conditions.

**Reduced Energy Costs:** Calculate energy savings online using BEC2 software at [www.bec2.net](http://www.bec2.net).

**Pump System Protection:** Dry Run detection, check valve ramp, pipe fill mode, Sleep mode, no/low flow detection, end of pump curve detection, integrated mains disconnect switch (optional), real-time clock battery backup.

**Phase Conversion:** Single phase input drives are available that convert to 3 phase output.

### Simple Setup:

**Pump and Motor Settings:** Above/Below Ground, Horsepower, Voltage, Current, Nominal Speed.

**System Learning:** No Load, Sleep, No Flow.

**Ready to Go!:** That's it. The drive is now ready for use. Following those simple steps to configure your system for constant pressure has you ready to move to the next job.

# Pentek Intellidrive™ XL Pump Controllers

## ORDERING INFORMATION

### SINGLE PHASE INPUT DRIVES

OUTPUT AMPS	INPUT VOLTAGE	INPUT PHASE	NEMA RATING	MODEL NUMBER		
24.2	230	1	NEMA 1	PID007512ND		
30.8				PID010012ND		
59.4				PID020012ND		
88				PID030012ND		
24.2				PID007532ND		
30.8			PID010032ND			
59.4			PID020032ND			
88			PID030032ND			
				PID007532ND		
				PID010032ND		
				PID020032ND		
				PID030032ND		

## ORDERING INFORMATION

### SINGLE PHASE INPUT DRIVES

OUTPUT AMPS	INPUT VOLTAGE	INPUT PHASE	NEMA RATING	MODEL NUMBER
24.2	230	1	NEMA 4X	PID007542ND
30.8				PID010042ND
59.4				PID020042ND
88				PID030042ND

## ORDERING INFORMATION

### THREE PHASE INPUT DRIVES

OUTPUT AMPS	INPUT VOLTAGE	INPUT PHASE	NEMA 1		NEMA 3R		NEMA 4X		OPEN CHASSIS
			NO DISCONNECT	DISCONNECT	NO DISCONNECT	DISCONNECT	NO DISCONNECT	DISCONNECT	NO DISCONNECT
4.6	230	3	PID001013ND	PID001013FD	PID001033ND	PID001033FD	PID001043ND	PID001043FD	PID001003ND
7.5			PID002013ND	PID002013FD	PID002033ND	PID002033FD	PID002043ND	PID002043FD	PID002003ND
10.6			PID003013ND	PID003013FD	PID003033ND	PID003033FD	PID003043ND	PID003043FD	PID003003ND
16.7			PID005013ND	PID005013FD	PID005033ND	PID005033FD	PID005043ND	PID005043FD	PID005003ND
24.2			PID007513ND	PID007513FD	PID007533ND	PID007533FD	PID007543ND	PID007543FD	PID007503ND
30.8			PID010013ND	PID010013FD	PID010033ND	PID010033FD	PID010043ND	PID010043FD	PID010003ND
46.2			PID015013ND	PID015013FD	PID015033ND	PID015033FD	PID015043ND	PID015043FD	PID015003ND
59.4			PID020013ND	PID020013FD	PID020033ND	PID020033FD	PID020043ND	PID020043FD	PID020003ND
74.8			PID025013ND	PID025013FD	PID025033ND	PID025033FD	PID025043ND	PID025043FD	PID025003ND
88			PID030013ND	PID030013FD	PID030033ND	PID030033FD	PID030043ND	PID030043FD	PID030003ND
115			PID040013ND	PID040013FD	PID040033ND	PID040033FD	PID040043ND	PID040043FD	PID040003ND
143			PID050013ND	PID050013FD	PID050033ND	PID050033FD	PID050043ND	PID050043FD	PID050003ND
170			PID060013ND	PID060013FD	PID060033ND	PID060033FD	PID060043ND	PID060043FD	PID060003ND
2.1			PID001014ND	PID001014FD	PID001034ND	PID001034FD	PID001044ND	PID001044FD	PID001004ND
3.4			PID002014ND	PID002014FD	PID002034ND	PID002034FD	PID002044ND	PID002044FD	PID002004ND
4.8			PID003014ND	PID003014FD	PID003034ND	PID003034FD	PID003044ND	PID003044FD	PID003004ND
8.2			PID005014ND	PID005014FD	PID005034ND	PID005034FD	PID005044ND	PID005044FD	PID005004ND
11			PID007514ND	PID007514FD	PID007534ND	PID007534FD	PID007544ND	PID007544FD	PID007504ND
14.5	PID010014ND	PID010014FD	PID010034ND	PID010034FD	PID010044ND	PID010044FD	PID010004ND		
21	PID015014ND	PID015014FD	PID015034ND	PID015034FD	PID015044ND	PID015044FD	PID015004ND		
27	PID020014ND	PID020014FD	PID020034ND	PID020034FD	PID020044ND	PID020044FD	PID020004ND		
34	PID025014ND	PID025014FD	PID025034ND	PID025034FD	PID025044ND	PID025044FD	PID025004ND		
40	PID030014ND	PID030014FD	PID030034ND	PID030034FD	PID030044ND	PID030044FD	PID030004ND		
52	PID040014ND	PID040014FD	PID040034ND	PID040034FD	PID040044ND	PID040044FD	PID040004ND		
65	PID050014ND	PID050014FD	PID050034ND	PID050034FD	PID050044ND	PID050044FD	PID050004ND		
80	PID060014ND	PID060014FD	PID060034ND	PID060034FD	PID060044ND	PID060044FD	PID060004ND		
105	PID075014ND	PID075014FD	PID075034ND	PID075034FD	PID075044ND	PID075044FD	PID075004ND		
130	PID100014ND	PID100014FD	PID100034ND	PID100034FD	PID100044ND	PID100044FD	PID100004ND		
160	PID125014ND	PID125014FD	PID125034ND	PID125034FD	PID125044ND	PID125044FD	PID125004ND		
1.7	PID001015ND	PID001015FD	PID001035ND	PID001035FD	PID001045ND	PID001045FD	PID001005ND		
2.7	PID002015ND	PID002015FD	PID002035ND	PID002035FD	PID002045ND	PID002045FD	PID002005ND		
3.9	PID003015ND	PID003015FD	PID003035ND	PID003035FD	PID003045ND	PID003045FD	PID003005ND		
6.1	PID005015ND	PID005015FD	PID005035ND	PID005035FD	PID005045ND	PID005045FD	PID005005ND		
9	PID007515ND	PID007515FD	PID007535ND	PID007535FD	PID007545ND	PID007545FD	PID007505ND		
11	PID010015ND	PID010015FD	PID010035ND	PID010035FD	PID010045ND	PID010045FD	PID010005ND		
18	PID015015ND	PID015015FD	PID015035ND	PID015035FD	PID015045ND	PID015045FD	PID015005ND		
22	PID020015ND	PID020015FD	PID020035ND	PID020035FD	PID020045ND	PID020045FD	PID020005ND		
27	PID025015ND	PID025015FD	PID025035ND	PID025035FD	PID025045ND	PID025045FD	PID025005ND		
34	PID030015ND	PID030015FD	PID030035ND	PID030035FD	PID030045ND	PID030045FD	PID030005ND		
41	PID040015ND	PID040015FD	PID040035ND	PID040035FD	PID040045ND	PID040045FD	PID040005ND		
52	PID050015ND	PID050015FD	PID050035ND	PID050035FD	PID050045ND	PID050045FD	PID050005ND		
62	PID060015ND	PID060015FD	PID060035ND	PID060035FD	PID060045ND	PID060045FD	PID060005ND		
83	PID075015ND	PID075015FD	PID075035ND	PID075035FD	PID075045ND	PID075045FD	PID075005ND		
100	PID100015ND	PID100015FD	PID100035ND	PID100035FD	PID100045ND	PID100045FD	PID100005ND		
131	PID125015ND	PID125015FD	PID125035ND	PID125035FD	PID125045ND	PID125045FD	PID125005ND		

NOTE: the output current (or amps) of the Pentek Intellidrive XL must be greater than or equal to the maximum rated motor current.

# Pentek® XE-6 6" Submersible Motors

Encapsulated Design



Delivers outstanding performance through lower amp draw and higher efficiencies, which yields lower operating costs. Combined with many durable, innovative, and advanced design features, the Pentek XE-6 is the perfect solution for your submersible motor needs.

## APPLICATIONS

High-thrust water well applications.

## SPECIFICATIONS

**Shaft:** 17-4 stainless steel

**Motor Casing:** 304 stainless steel

**Upper and Lower Bracket:** Epoxy-coated cast iron – coating is TNEMEC 140, an NSF-certified coating

**Upper Bracket:** “dual-flange” design

**Motor Lead:** XLPE

**Thrust Bearing:** Water-lubricated, Kingsbury-type

**Pressure Equalizing Diaphragm:** Spring-less design

## FEATURES

Exceptional insulation rating (Class F) and temperature rating (95 F / 35 C)

IP68 protection rating

VFD-compatible

Vertical or Horizontal operation

## EXCLUSIVE ADVANCED PROTECTION SYSTEM

Provides **THREE** layers of defense against sand and debris intrusion

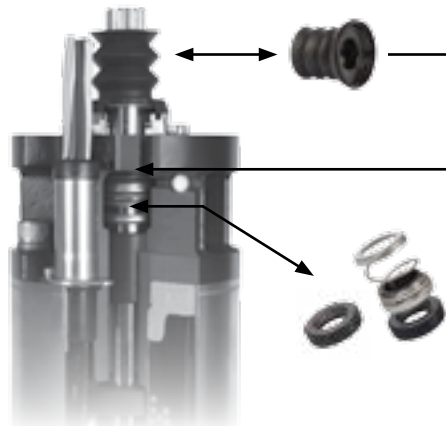

### 1) External sand slinger boot

- Features a labyrinth seal design to better capture any sand or debris, keeping it away from the shaft

### 2) Lip seal

- Located below the sand slinger, providing an extra layer of protection

### 3) Mechanical seal – silicon carbide

- Excellent abrasion, wear, and corrosion resistance
- Resists deflection in high-pressure, high-heat, and high-speed conditions
- High thermal conductivity (heat dissipation)
- Provides superior protection against sand intrusion

# Pentek® XE-6 6" Submersible Motors

Encapsulated Design

## MOTOR PERFORMANCE AND DIMENSIONAL DATA

Nominal Diameter – 6" / 152.4mm  
 Effective Diameter – 5.43" / 138mm  
 60Hz • 2 POLE • 3450 RPM  
 CLASS F INSULATION  
 Shaft Extension – 2.87" / 73mm

### ORDERING INFORMATION

PHASE	MODEL #	HP	KW	VOLTS	FULL LOAD				SERVICE FACTOR 1.15				LOCKED ROTOR AMPS	THRUST LOAD (LBS)	KVA CODE	LENGTH (includes shaft ext)		WEIGHT		CRATE						WEIGHT MOTOR+CRATE										
					AMPS	WATTS	EFF %	PF %	AMPS	WATTS	EFF %	PF %				IN	MM	LBS	KG	L		W		H		LBS	KG									
																				IN	MM	IN	MM	IN	MM											
1	P60A0050A2	5	3.70	230	22.8	4975	74.5	97.0	26.0	5625	75.5	97.0	104	3600	E	25.6	650	104	47.2	48	1219	10	254	13.5	343	134	60.8									
	P60A0075A2	7.5	5.60		35.2	7300	77.0	92.0	40.0	8300	77.5	92.5	162		F	28.1	714	117	53.1							151	68.5									
	P60A0100A2	10	7.50		45.7	9700	76.5	94.0	52.4	11175	76.5	94.0	202		E	30.3	770	132	59.9							166	75.3									
	P60A0150A2	15	11.20		62.4	13725	81.5	98.0	72.5	15825	81.5	98.0	296		E	32.8	833	144	65.3							178	80.7									
2	P60A0050A8	5	3.7	200-208	16.1	4830	77.5	86.5	18.0	5490	78.5	88.0	96	3600	H	23.0	583	87	39.5	48	1219	10	254	13.5	343	115	52.2									
	P60A0075A8	7.5	5.5		23.3	7000	80.0	87.5	26.8	8070	80.0	88.5	140		H	24.3	618	97	44.0							127	57.6									
	P60A0100A8	10	7.5		31.5	9090	82.5	86.5	35.0	10400	82.5	88.0	187		H	25.6	650	104	47.2							134	60.8									
	P60A0150A8	15	11		44.9	13440	83.5	87.0	50.8	15460	83.5	88.5	268		H	28.1	713	117	53.1							151	68.5									
	P60A0200A8	20	15		59.0	17850	83.0	87.5	67.1	20630	83.0	89.0	354		H	30.3	770	132	59.9							166	75.3									
	P60A0250A8	25	19		76.8	22110	84.0	85.5	86.5	25520	84.0	87.5	445		H	32.8	834	144	65.3							180	81.6									
	P60A0300A8	30	22		91.7	26420	84.5	86.0	103.3	30450	84.5	87.5	530		H	35.6	904	165	74.8							207	93.9									
	P60A0050A3	5	3.7		14.4	4830	77.5	86.5	16.1	5490	78.5	88.0	87		3600	H	23.0	583	87							39.5	48	1219	10	254	13.5	343	115	52.2		
	P60A0075A3	7.5	5.5		21.5	7000	80.0	87.5	24.1	8070	80.0	88.5	127			H	24.3	618	97							44.0							127	57.6		
	P60A0100A3	10	7.5		28.0	9090	82.5	86.5	31.5	10400	82.5	88.0	164			H	25.6	650	104							47.2							134	60.8		
	P60A0150A3	15	11		40.9	13440	83.5	87.0	46.3	15460	83.5	88.5	237			H	28.1	713	117							53.1							151	68.5		
	P60A0200A3	20	15		53.2	17850	83.0	87.5	60.8	20630	83.0	89.0	312			G	30.3	770	132							59.9							166	75.3		
P60A0250A3	25	19	66.7	22110	84.0	85.5	76.0	25520	84.0	87.5	387	G	32.8	834		144	65.3	180	81.6																	
P60A0300A3	30	22	79.3	26420	84.5	86.0	90.2	30450	84.5	87.5	458	G	35.6	904		165	74.8	207	93.9																	
3	P60A0050A4	5	3.7	460	7.0	4830	77.5	86.5	8.0	5490	78.5	88.0	44	6750		H	23.0	583	87	39.5	48	1219	10	254	13.5	343							115	52.2		
	P60A0075A4	7.5	5.5		10.0	7000	80.0	87.5	11.3	8070	80.0	88.5	62			H	24.3	618	97	44.0													127	57.6		
	P60A0100A4	10	7.5		13.1	9090	82.5	86.5	14.8	10400	82.5	88.0	82			H	25.6	650	104	47.2													134	60.8		
	P60A0150A4	15	11		20.4	13440	83.5	87.0	23.0	15460	83.5	88.5	117			G	28.1	713	117	53.1													151	68.5		
	P60A0200A4	20	15		25.8	17850	83.0	87.5	29.4	20630	83.0	89.0	151			G	30.3	770	132	59.9													166	75.3		
	P60A0250A4	25	19		32.8	22110	84.0	85.5	36.8	25520	84.0	87.5	187		G	32.8	834	144	65.3	180							81.6									
	P60A0300A4	30	22		39.3	26420	84.5	86.0	44.6	30450	84.5	87.5	226		G	35.6	904	165	74.8	207							93.9									
	P60A0400A4	40	30		51.3	35030	85.0	87.5	58.6	40500	85.0	89.0	302		G	39.3	999	187	84.8	229							103.9									
	P60A0500A4	50	37		65.8	44350	84.0	87.0	75.1	51200	84.0	88.0	385		G	54.1	1374	265	120.2	319							144.7									
	4	P60A0050A5	5		3.7	575	5.8	4830	77.5	86.5	6.5	5490	78.5		88.0	35	3600	H	23.0	584							87	39.5	48	1219	10	254	13.5	343	115	52.2
		P60A0075A5	7.5		5.5		8.2	7000	80.0	87.5	9.3	8070	80.0		88.5	51		H	24.3	617							97	44.0							127	57.6
		P60A0100A5	10		7.5		10.5	9090	82.5	86.5	11.8	10400	82.5		88.0	61		G	25.6	650							104	47.2							134	60.8
		P60A0150A5	15		11		15.0	13440	83.5	87.0	17.1	15460	83.5		88.5	88		G	28.1	714							117	53.1							151	68.5
		P60A0200A5	20		15		20.9	17850	83.0	87.5	23.7	20630	83.0		89.0	122		G	30.3	770							132	59.9							166	75.3
		P60A0250A5	25		19		26.2	22110	84.0	85.5	29.7	25520	84.0		87.5	153		G	32.8	833							144	65.3							180	81.6
		P60A0300A5	30		22		31.0	26420	84.5	86.0	35.0	30450	84.5		87.5	179		G	35.6	904							165	74.8							207	93.9
P60A0400A5		40	30	41.5	35030		85.0	87.5	47.3	40500	85.0	89.0	247	G	39.3	998		187	84.8	229	103.9															

# Pentek® XE-6 Controls

For Pentek XE-6 Single Phase Motors



**14 ga steel enclosure with polyester powder-coated paint**

- Heavy-duty construction, high durability and corrosion-resistance

**Continuous hinge door**

- Easy access – no need to remove during installation or service
- Opens past 180° for easy access

**Integral mounting flange**

- Easy to wall-mount while maintaining NEMA 4 rating

**Multiple knockout (embossed) options**

- 2 - dual 1/2" - 3/4"
- 2 - dual 3/4" - 1"
- 2 - dual 1-1/4" - 1- 1/2"

**Seamless, foamed-in-place door gasket**

- Excellent protection against intrusion from dirt, dust, rain, sleet, snow or wind-directed water

**Bonding provision on door**

- When required by code

**NEMA 4 rated enclosure (compare to competition at only NEMA 3)**

**IP66 Ingress Protection rating**

**Opens with two quarter-turn latches**

- No risk of lost door fasteners, no tools needed

**Locking Hasp**

- Added security

**Size - 16" x 14"**

- Generous size allows for more room to work inside the box

- Easier conduit attachment, wire pulling, and wire connections

**Terminals accept up to 4AWG wire**

**Magnetic line contactors**

- Included standard on each box

**Removable back panel**

- All electric components mounted on panel
- Easy installation and servicing, when downtime is critical

## Pentek Single Phase Control Boxes For Pentek XE-6 Single Phase Motors

60Hz • 2 POLE

**ORDERING INFORMATION**

PHASE	MODEL #	HP	KW	VOLTS	CONTROL BOX DIMENSIONS						LBS	KG
					HEIGHT		WIDTH		DEPTH			
					IN	MM	IN	MM	IN	MM		
1	PTKX-5SCB	5	3.70	230	14.0	356	12.0	304.8	6.0	152.4	30	13.6
	PTKX-7SCB	7.5	5.60								32	14.5
	PTKX-10SCB	10	7.50								33.2	15.1
	PTKX-15SCB	15	11.20									

**FAST SHIPPING**

Available same day from the following Pentair locations:

Fresno, CA; Grand Island, NE; Delavan, WI; Jacksonville, FL; Lubbock, TX

Motors not stocked at your nearest facility will be drop shipped from another stocking location

**PRE-PAID FREIGHT**

Pre-paid freight to distributor location on one or more motors.

If motor order is combined with other Pentair products, standard pre-paid freight terms apply.

**WARRANTY**

12 months from Date of Installation / 24 months from Date of Manufacture

For members of the Pro Dealer program, warranty is 24 months from Date of Installation / 36 months from Date of Manufacture

# Hitachi® 6" Submersible Motors

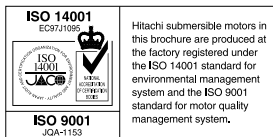

Hitachi Motors are designed and manufactured to provide long service life and trouble-free operation. Innovative design and robust characteristics make this the perfect motor for your pumping applications.

Combined with exceptional insulation and a patented epoxy fill resin, these motors exceed NEMA requirements for high water temperature by 18°F (10°C). Designed with internal lubrication and cooling blend of water, antifreeze, and an antirust mixture, Hitachi submersible motors are unique in providing the industry with innovative and robust design features that will extend the serviceable life of your installation.

## APPLICATIONS

High-thrust, deep water well applications.

## SPECIFICATIONS

**Motor Sleeve:** Stainless steel construction

**Castings:** Baked epoxy-coated gray cast iron

**Fasteners:** Stainless steel

**Shaft:** NEMA splined stainless steel

**Flange:** NEMA standard type

**Rotor:** Double epoxy-coated

**Thrust Bearings:** Kingsbury-type 420 stainless steel

**Double Lip Seals:** Nitrile rubber (NBR), sand-resistant, grease-packed for harsh, sandy well conditions

**Diaphragm:** Nitrile rubber

**Sand Cap:** Polyurethane

**Sand Slinger:** Stainless steel

**Lead Wire (or Cable):** Double-insulated, heat and water-resistant, 167°F/75°C, 600V

## FEATURES

**Higher Efficiencies and Lower Current Consumption:** For reduced energy costs.

**Carbon Bearings:** Two water-lubricated carbon bearings, for extra alignment support, serve as a steady bushing for the motor.

**Corrosion-Resistant Design:** For long life.

**High-Capacity Kingsbury-Type Bearings:** For dependable performance.

**Low-Profile NEMA Design:** For ease of installation.

**Replaceable Plug-in Motor Lead:** For ease of maintenance.

**Dual Voltage Type:** For application versatility (5HP – 30HP, 230V or 460V, 3-phase motors).

**VFD-Compatible**

## Hitachi Control Box – Single Phase, 230V (Required for Hitachi 1Ø motors)

- Type 1 NEMA Enclosure
- In-Panel Circuit Breaker
- Magnetic Contactor
- Terminal Blocks for External Controls
- UL Recognized



Hitachi single phase motors must use a Hitachi control box. Use of any other control box will void the warranty.

# Hitachi® 6" Submersible Motors

## ORDERING INFORMATION

HP	KW	VOLTS	PH	SERVICE FACTOR	CATALOG NUMBER	RATED INPUT AMPS	SERVICE FACTOR INPUT AMPS	WINDING RESISTANCE (OHMS)	THRUST CAPACITY	LENGTH (L)		DIAMETER (D)		WEIGHT	
										IN.	MM	IN.	MM	LBS.	KG
<b>6" DIAMETER 60 HZ</b>															
5	3.7	200	3	1.15	6HIT2-5-8	17.5	19.5	RTF	3,500	22.95"	582.9	5.5"	139.7	95	43.0
5	3.7	230	1	1.15	6HIT2-5-1	24	27.5	R-Y, B-Y, R-B, 2.172, 0.512, 2.627	3,500	26.97"	685.0	5.5"	139.7	110	49.9
5	3.7	230	3	1.15	6HIT2-5-2	15	17	0.806	3,500	22.95"	582.9	5.5"	139.7	95	43.0
5	3.7	460	3	1.15	6HIT2-5-4	7.5	8.5	3.05	3,500	22.95"	582.9	5.5"	139.7	95	43.0
7.5	5.5	200	3	1.15	6HIT2-7-8	25.4	28.5	RTF	3,500	24.80"	629.9	5.5"	139.7	99	43.0
7.5	5.5	230	1	1.15	6HIT2-7-1	36	41	R-Y, B-Y, R-B, 1.401, 0.400, 1.774	3,500	29.92"	760.0	5.5"	139.7	128	58.1
7.5	5.5	230	3	1.15	6HIT2-7-2	22	26	0.651	3,500	24.80"	629.9	5.5"	139.7	99	43.0
7.5	5.5	460	3	1.15	6HIT2-7-4	11	13	2.43	3,500	24.80"	629.9	5.5"	139.7	99	43.0
10	7.5	200	3	1.15	6HIT2-10-8	33.3	37.2	RTF	3,500	26.97"	685.0	5.5"	139.7	110	49.9
10	7.5	230	1	1.15	6HIT2-10-1	50	58	R-Y, B-Y, R-B, 1.052, 0.316, 1.310	3,500	29.92"	760.0	5.5"	139.7	128	58.1
10	7.5	230	3	1.15	6HIT2-10-2	29	33	0.448	3,500	26.97"	685.0	5.5"	139.7	110	49.9
10	7.5	460	3	1.15	6HIT2-10-4	14.5	16.5	1.619	3,500	26.97"	685.0	5.5"	139.7	110	49.9
15	11	200	3	1.15	6HIT2-15-8	47.4	53.5	RTF	3,500	29.92"	760.0	5.5"	139.7	128	58.1
15	11	230	1	1.15	6HIT2-15-1	72	85	R-Y, B-Y, R-B, 0.678, 0.230, 0.850	3,500	33.46"	849.9	5.5"	139.7	148	67.1
15	11	230	3	1.15	6HIT2-15-2	42	46	0.312	3,500	29.92"	760.0	5.5"	139.7	128	58.1
15	11	460	3	1.15	6HIT2-15-4	21	23	1.074	3,500	29.92"	760.0	5.5"	139.7	128	58.1
20	15	200	3	1.15	6HIT2-20-8	61.2	69.5	RTF	3,500	31.5"	800.1	5.5"	139.7	137	62.1
20	15	230	3	1.15	6HIT2-20-2	54	60	0.258	3,500	31.5"	800.1	5.5"	139.7	137	62.1
20	15	460	3	1.15	6HIT2-20-4	27	30	0.861	3,500	31.5"	800.1	5.5"	139.7	137	62.1
25	18.5	200	3	1.15	6HIT2-25-8	77.3	87.5	RTF	3,500	36.22"	920.0	5.5"	139.7	161	73.0
25	18.5	230	3	1.15	6HIT2-25-2	68	76	0.21	3,500	36.22"	920.0	5.5"	139.7	161	73.0
25	18.5	460	3	1.15	6HIT2-25-4	34	38	0.666	3,500	36.22"	920.0	5.5"	139.7	161	73.0
30	22	200	3	1.15	6HIT2-30-8	91.8	104	RTF	3,500	38.19"	970.0	5.5"	139.7	176	79.8
30	22	230	3	1.15	6HIT2-30-2	82	94	0.166	3,500	39.19"	970.0	5.5"	139.7	176	79.8
30	22	460	3	1.15	6HIT2-30-4	41	47	0.554	3,500	38.19"	970.0	5.5"	139.7	176	79.8
40	30	460	3	1.15	6HIT2-40-4	56	61	0.358	5,000	40.55"	1,030.0	5.5"	139.7	187	84.8
<b>8" DIAMETER 60 HZ</b>															
50	37	460	3	1.15	86HIT2-50-4*	65	73	0.331	5,000	45.28"	1,150.0	7.52"	191.0	353	160.1
60	45	460	3	1.15	86HIT2-60-4*	80	90	0.278	5,000	48.03"	1,220.0	7.52"	191.0	408	185.1

NOTE: 6" motors are 3450 rpm, 60 Hz, 1.15 SF.

\*8" motor with 6" pump connection

**Hitachi single phase motors must use a Hitachi control box. Use of any other control box will void the warranty.**

### OUTLINE DIMENSIONS

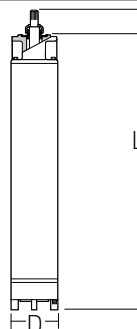

Shaft Extension  
2.87" (72.9 mm)

For lengths, refer to Ordering Information tables.

Dimensions are for estimating purposes only.

### ORDERING INFORMATION

HP	KW	VOLTS	PH	CATALOG NUMBER
<b>HITACHI CONTROL BOX</b>				
5	3.7	230	1	HIT-5CBD
7.5	5.5	230	1	HIT-7.5CBD
10	7.5	230	1	HIT-10CBD
15	11	230	1	HIT-15CBD

# CJ Series

Self-priming shallow well jet pumps, stainless steel body



CJ models provide excellent performance with good pressure for wells to 25' deep. Self-priming after the priming chamber has been filled with water.

## APPLICATIONS

Water systems and sprinkling... for homes, farms and cottages.

## SPECIFICATIONS

**Maximum Liquid Temperature Limits:** 122°F (50°C)

**Max. Inlet Pressure:** 50 PSI

**Average Priming Time at 20 Feet:**

CJ90E = 5.3 min.

CJ90F = 4.2 min.

**Body:** 304 Stainless steel

**Jet Assembly, Diffuser, Impeller:** Noryl®

**Shaft:** One-piece threaded, 416 grade stainless steel

**Base:** Polypropylene

## FEATURES

**Corrosion Free:** Stainless steel pump body provides maximum resistance to corrosion.

**Built-in Jet:** High-strength thermoplastic components are corrosion resistant.

**Mechanical Shaft Seal:** Highly polished carbon-ceramic and stainless steel construction.

**Motor Windings:** Superior insulation materials protect against excessive moisture and contaminants... assure prolonged motor life.

**Balanced Rotor:** Diecast under high pressures for uniform performance and greater efficiency, dynamically balanced.

**Heavy-Duty Ball Bearings:** Shielded, permanently lubricated bearings, extensively tested to ensure extended life and smooth, quiet operation.

**Pump and Motor Shaft:** Stainless steel for maximum corrosion resistance; one-piece threaded shaft for positive impeller drive and alignment.

**Dustproof Cover:** All electrical components are protected from dirt, dust and insects by a dustproof canopy; ventilating air cannot contaminate vital switching components.

**Pressure Switch:** Quality, fixed differential (20 PSI).

## ORDERING INFORMATION

CATALOG NUMBER	HP	SWITCH SETTING	DESCRIPTION	PIPE TAPPING SIZES		MOTOR VOLTAGE	APPROX. WT. LBS.
				SUCTION	DISCHARGE		
CJ90E	1	30-50	Shallow Well Jet	1-1/4"	1"	115/230	26
CJ90F	1-1/2	40-60	Shallow Well Jet	1-1/4"	1"	115/230	29

# CJ Series

Self-priming shallow well jet pumps, stainless steel body

## PUMP PERFORMANCE

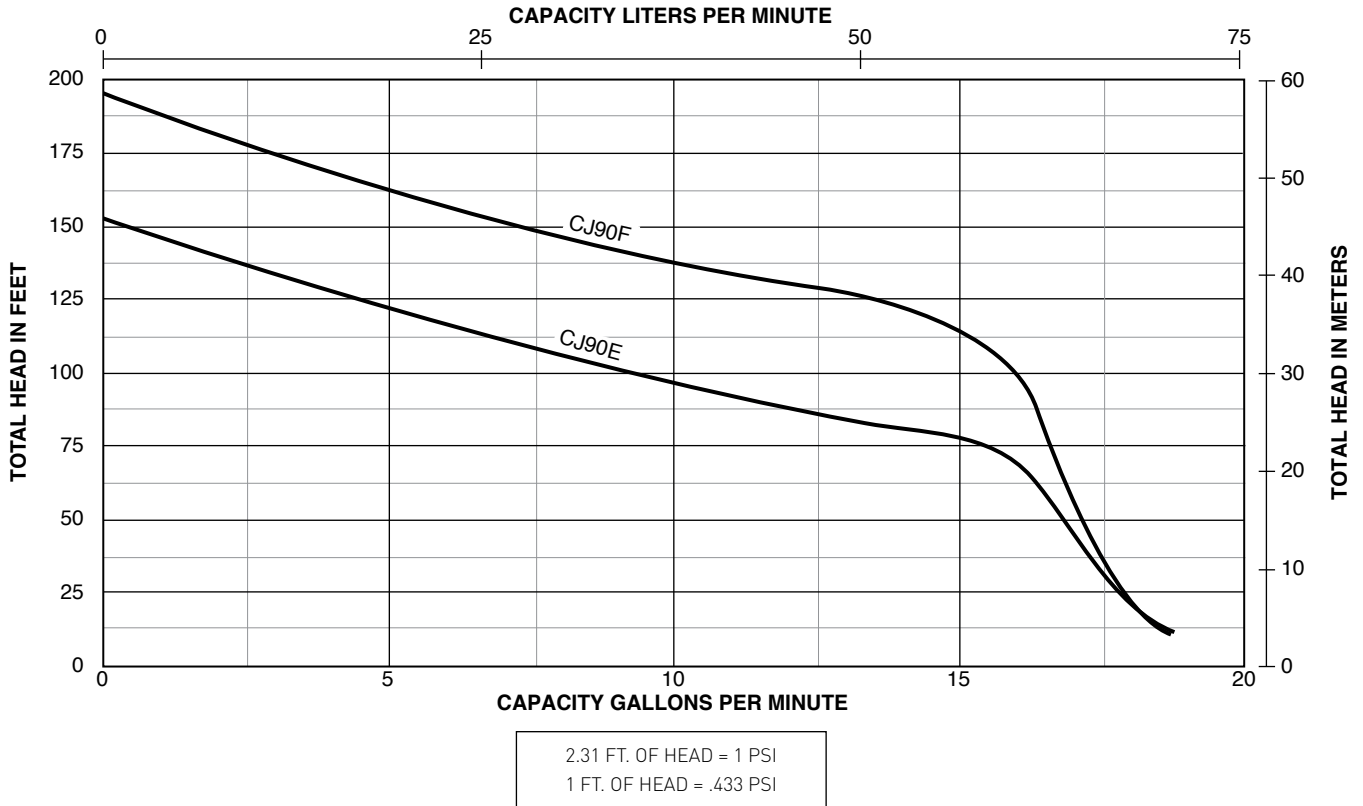

### PUMP PERFORMANCE (Capacity in gallons per minute)

CATALOG NUMBER	HP	DISCH. PRESSURE PSI	DEPTH TO WATER					SHUT-OFF PRESSURE PSI
			5'	10'	15'	20'	25'	
CJ90E	1	30	16.1	14.4	12.6	10.1	7.5	64
		40	11	11	11	9.0	7.2	
		50	5.8	5.8	5.8	5.8	5.8	
CJ90F	1-1/2	40	16.2	14.6	12.6	10.6	7.5	80
		50	15.4	14.3	12.3	10.3	7.3	
		60	9.5	9.5	9.5	9.5	7.1	

Tested and rated in accordance with Water Systems Council Standards.

NOTE: CJ90E uses 30-50 PSI pressure switch; CJ90F uses 40-60 PSI pressure switch.

Pumps installed with a Pro-Source® tank require a 100 PSI relief valve. Pumps installed with a conventional tank require a 75 PSI relief valve. Relief valve must be capable of relieving entire flow of pump at relief pressure.

# CJ Series

Self-priming shallow well jet pumps, stainless steel body

## OUTLINE DIMENSIONS

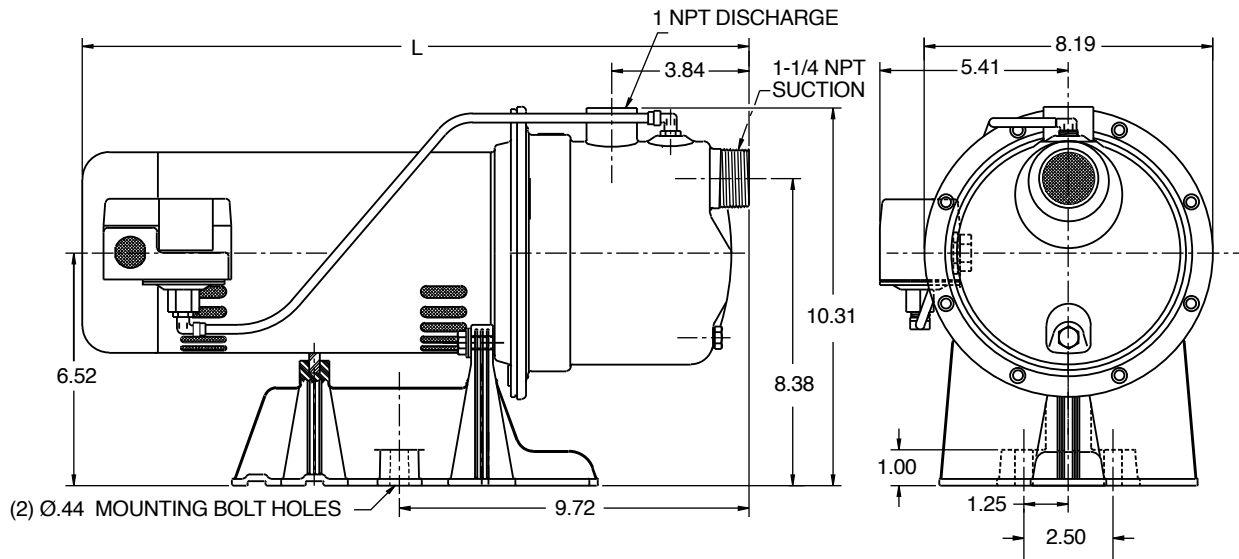

CATALOG NUMBER	L
CJ9E	18.19
CJ90F	19.25

Dimensions (in inches) are for estimating purposes only.

# ProJet™ HN Series

Cast iron, self-priming shallow well jet pumps

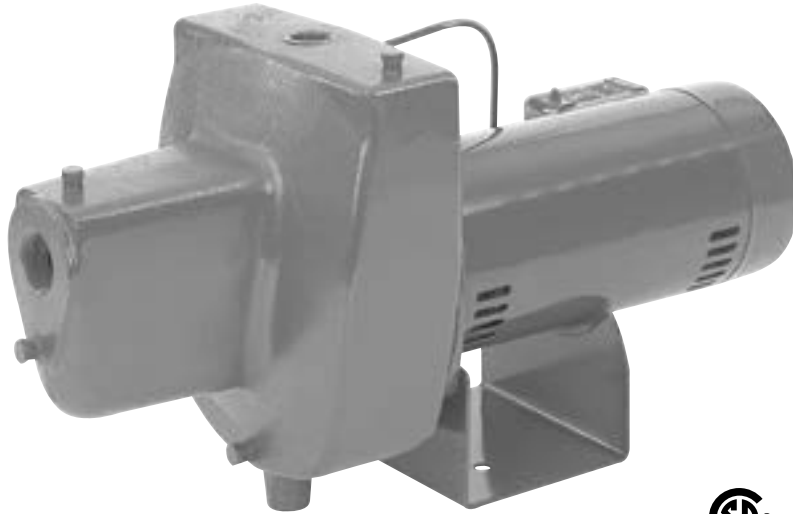

The ProJet HN models provide excellent performance with good pressure for wells to 25' deep. Self-priming after the priming chamber has been filled with water.

## APPLICATIONS

Water systems and sprinkling... for homes, farms and cottages.

## SPECIFICATIONS

**Max. Liquid Temperature:** 140°F

**Max. Inlet Pressure:** 50 PSI

**Average Priming Time (in minutes) at 15 Feet:**

HNC = 1.7; HND = 1.1; HNE = 1.3

**Average Priming Time (in minutes) at 25 Feet:**

HNC = 4.4; HND = 4.4; HNE = 2.6

**Body:** Close-grained cast iron

**Nozzle:** High-strength Lexan®

**Venturi:** Lexan®

**Impeller:** Noryl®

**Diffuser:** Reinforced polypropylene

**Shaft:** One-piece threaded, 416 grade stainless steel

**Base:** Steel, 12 gauge

## FEATURES

**Quality Construction:** Close-grained cast iron body, specially treated for corrosion resistance. Drain port provided for easy winterizing.

**Built-in Jet:** High-strength Lexan nozzle and venturi for maximum resistance to corrosion and abrasion. Cleanout plug provided for ease of service.

**Noryl Impeller:** Precision-molded for perfect balance...ultra-smooth for highest performance and efficiency.

**Precision-Molded Diffuser:** Pump primes faster, handles more air, with multi-port, precision-molded, reinforced polypropylene diffuser.

**Mechanical Shaft Seal:** Precision lapped and highly polished carbon-ceramic, stainless steel construction. Internal design guarantees continuous water lubrication.

**Motor Windings:** Superior insulation materials protect against excessive moisture and contaminants...assure prolonged motor life.

**Balanced Rotor:** Diecast under high pressures for uniform performance and greater efficiency, dynamically balanced.

**Heavy-Duty Ball Bearings:** Shielded, permanently lubricated bearings, extensively tested to ensure extended life and smooth, quiet operation.

**Pump and Motor Shaft:** Stainless steel for maximum corrosion resistance; one-piece threaded shaft for positive impeller drive and alignment.

**Pressure Switch:** Professional quality, allows cut-in and differential adjustments.

## ORDERING INFORMATION

CATALOG NUMBER	HP	SWITCH SETTING	DESCRIPTION	PIPE TAPPING SIZES		MOTOR VOLTAGE	APPROX. WT. LBS.
				SUCTION	DISCHARGE		
HNC	1/2	30-50	Shallow Well Jet	1-1/4"	1"	115/230	47
HND	3/4	30-50	Shallow Well Jet	1-1/4"	1"	115/230	65
HNE	1	30-50	Shallow Well Jet	1-1/4"	1"	115/230	70

Pentair trademarks and logos are owned by Pentair plc or its affiliates. All other third party registered and unregistered trademarks and logos are the property of their respective owners.

# ProJet™ HN Series

Cast iron, self-priming shallow well jet pumps

## PUMP PERFORMANCE

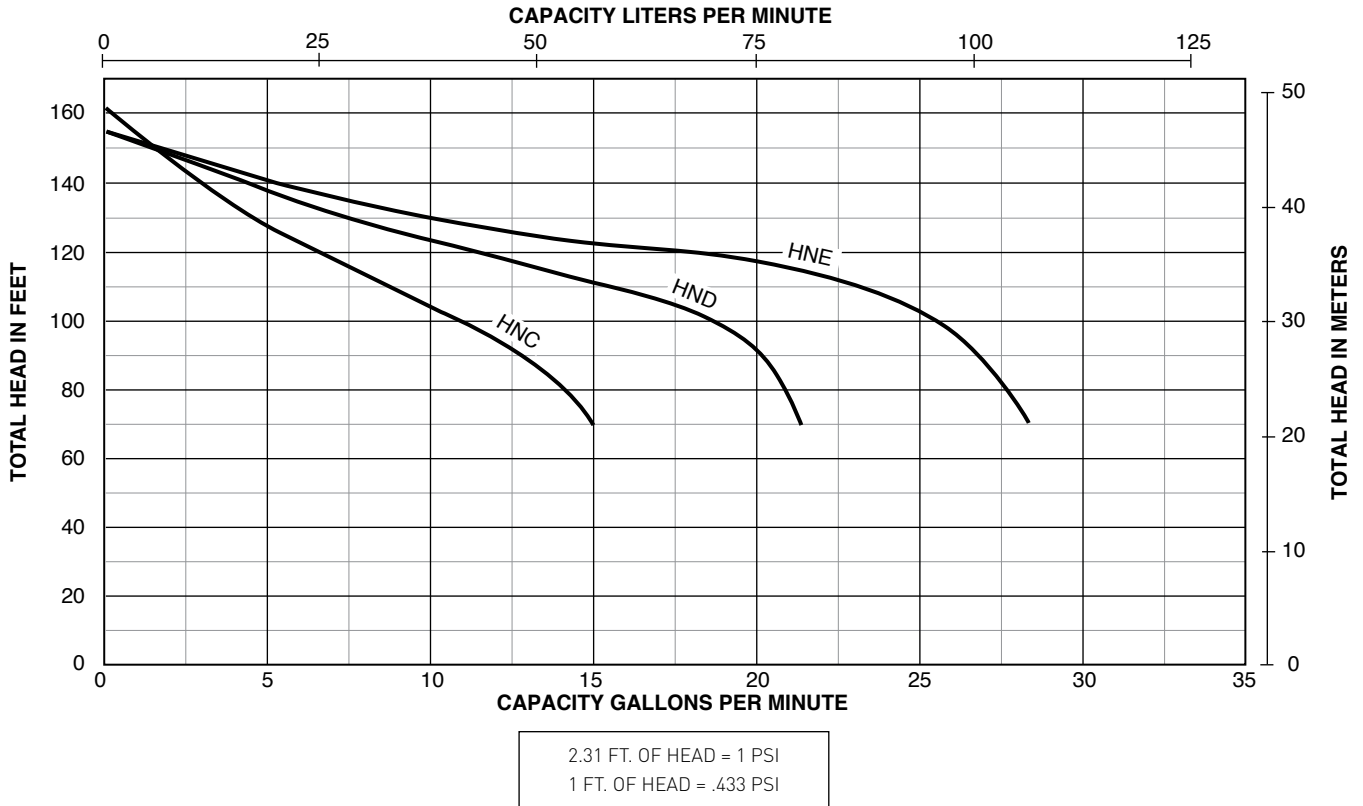

## PUMP PERFORMANCE (Capacity in gallons per minute)

CATALOG NUMBER	HP	DISCH. PRESSURE PSI	DYNAMIC SUCTION LIFT					SHUT-OFF PRESSURE PSI
			5'	10'	15'	20'	25'	
HNC	1/2	30	15.0	13.0	11.6	8.7	6.9	70
		40	12.5	11.4	10.1	8.2	6.8	
		50	8.0	6.8	6.1	4.8	3.5	
HND	3/4	30	21.4	19.1	16.5	13.3	9.5	67
		40	20.8	18.7	15.8	13.2	9.3	
		50	13.5	11.6	10.1	7.4	2.4	
HNE	1	30	28.5	25.0	21.4	17.4	12.6	67
		40	28.3	24.4	21.0	17.2	12.3	
		50	21.5	18.3	10.9	3.1	1.6	

Pump will operate at all depths shown, with pressure switch set at 30-50 PSI.

Tested and rated in accordance with Water Systems Council Standards.

NOTE: Pumps installed with a Pro-Source® tank require a 100 PSI relief valve. Pumps installed with a conventional tank require a 75 PSI relief valve. Relief valve must be capable of relieving entire flow of pump at relief pressure.

# ProJet™ HN Series

Cast iron, self-priming shallow well jet pumps

## OUTLINE DIMENSIONS

CATALOG NUMBER	L	B
HNC	18.7	7.1
HND	21.3	7.0
HNE	22.4	8.0

HNC

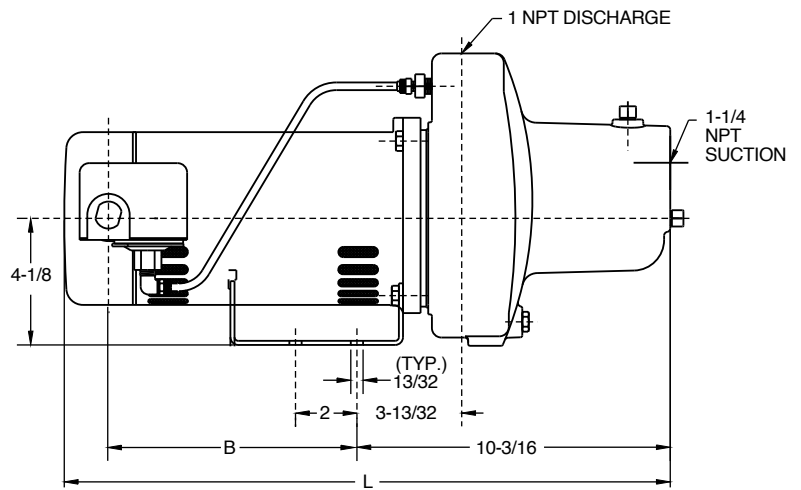
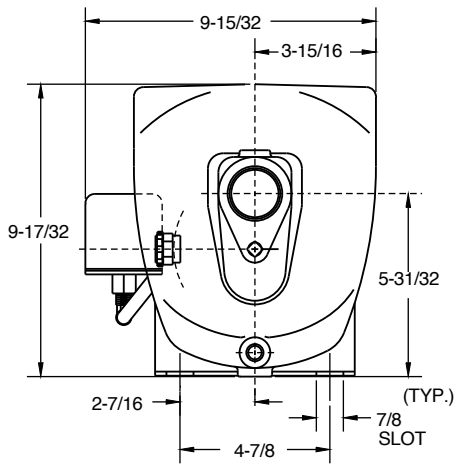

HND and HNE

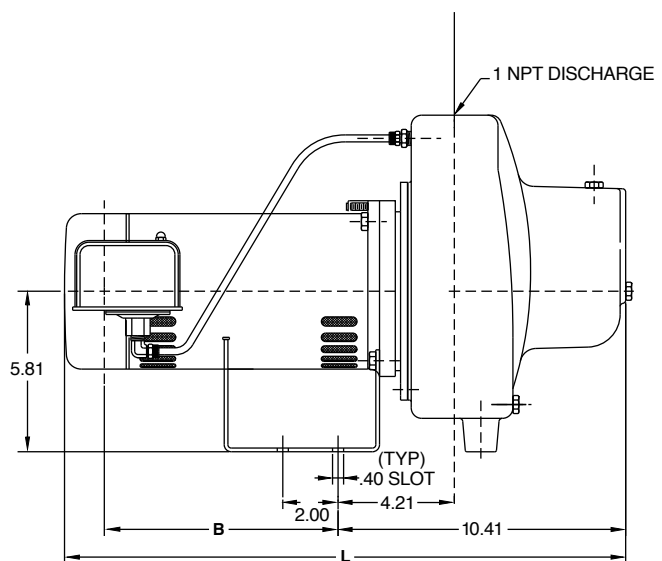
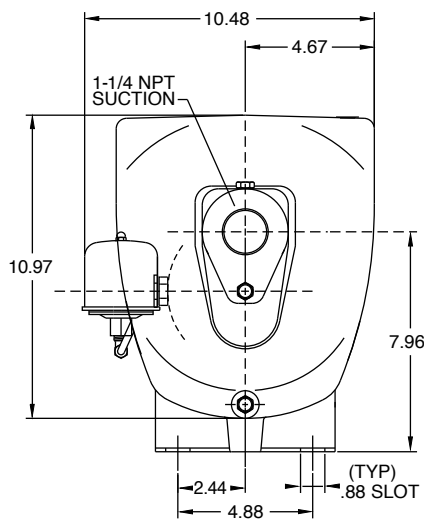

Dimensions (in inches) are for estimating purposes only.

# ProJet™ SN Series

Cast iron, self-priming shallow well jet pumps

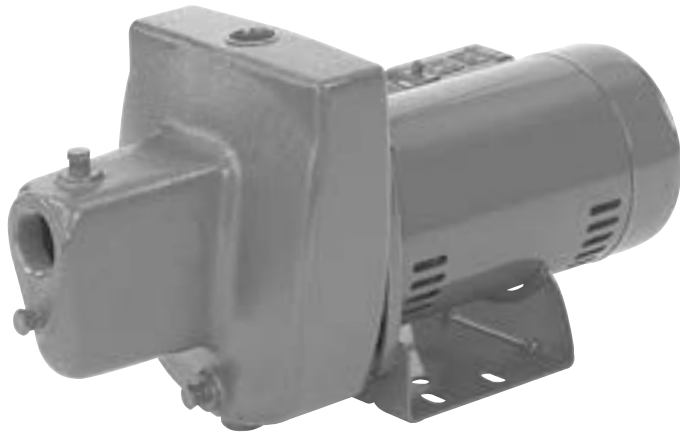

The ProJet SN Series Pumps provide excellent performance with good pressure for wells to 25' deep. Self-priming after the priming chamber has been filled with water.

## APPLICATIONS

Water systems and sprinkling... for homes, farms and cottages.

## SPECIFICATIONS

**Max. Liquid Temperature:** 140°F

**Max. Inlet Pressure:** 50 PSI

**Average Priming Time (in minutes) at 15 Feet:**

SNC = 2.3; SND = 1.7

SNE = 1.3; SNF = 1.1

**Average Priming Time (in minutes) at 25 Feet:**

SNC = 6.4; SND = 4.4

SNE = 4.4; SNF = 2.6

**Body:** Close-grained cast iron

**Nozzle:** High-strength Lexan®

**Venturi:** Lexan

**Impeller:** Noryl®

**Diffuser:** Reinforced polypropylene

**Shaft:** One-piece threaded, 416 grade stainless steel

**Base:** Steel, 12 gauge

## FEATURES

**Quality Construction:** Close-grained cast iron body. Drain port provided for easy winterizing.

**Built-in Jet:** High-strength Lexan nozzle and venturi for maximum resistance to corrosion and abrasion. Cleanout plug provided for ease of service.

**Noryl Impeller:** Precision-molded for perfect balance...ultra-smooth for highest performance and efficiency.

**Precision-Molded Diffuser:**

Pump primes faster, handles more air, with multi-port, precision-molded, reinforced polypropylene diffuser.

**Mechanical Shaft Seal:** Precision lapped and highly polished carbon-ceramic, stainless steel construction. Internal design guarantees continuous water lubrication.

**Motor Windings:** Superior insulation materials protect against excessive moisture and contaminants...assure prolonged motor life.

**Balanced Rotor:** Diecast under high pressures for uniform performance and greater efficiency, dynamically balanced.

**Heavy-Duty Ball Bearings:** Shielded, permanently lubricated bearings, extensively tested to ensure extended life and smooth, quiet operation.

**Pump and Motor Shaft:** Stainless steel for maximum corrosion resistance; one-piece threaded shaft for positive impeller drive and alignment.

**Dustproof Cover:** All electrical components are protected from dirt, dust and insects by a dustproof canopy; ventilating air cannot contaminate vital switching components.

**Pressure Switch:** Professional quality, allows cut-in adjustments.

## ORDERING INFORMATION

CATALOG NUMBER	HP	SWITCH SETTING	DESCRIPTION	PIPE TAPPING SIZES		MOTOR VOLTAGE	APPROX. WT. LBS.
				SUCTION	DISCHARGE		
SNC-HF25L	1/2	20-40	Hi Flow, Shallow Well Jet	1-1/4"	1"	115/230	45
SNC	1/2	30-50	Shallow Well Jet	1-1/4"	1"	115/230	45
SND	3/4	30-50	Shallow Well Jet	1-1/4"	1"	115/230	47
SNE	1	30-50	Shallow Well Jet	1-1/4"	1"	115/230	55
SNF	1-1/2	30-50	Shallow Well Jet	1-1/4"	1"	115/230	60

# ProJet™ SN Series

Cast iron, self-priming shallow well jet pumps

## PUMP PERFORMANCE

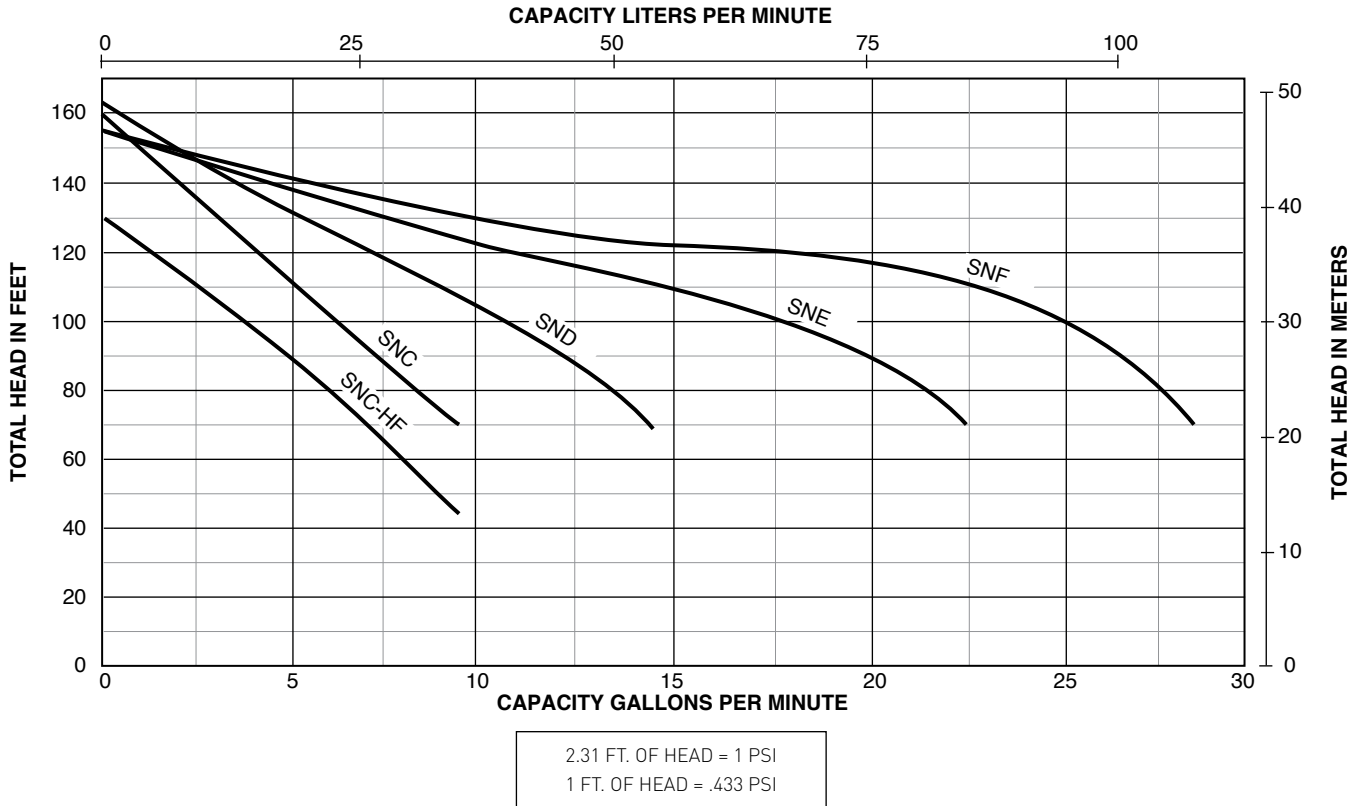

## PUMP PERFORMANCE (Capacity in gallons per minute)

CATALOG NUMBER	HP	DISCH. PRESSURE PSI	DYNAMIC SUCTION LIFT					SHUT-OFF PRESSURE PSI
			5'	10'	15'	20'	25'	
SNC-HF25L	1/2	20	13.7	12.3	10.6	8.8	6.3	56
		30	11.8	10.6	9.3	8.2	6.2	
		40	7.2	6.3	5.2	4.0	2.4	
SNC	1/2	30	9.7	8.3	7.4	5.9	4.3	70
		40	7.9	7.2	6.4	5.6	4.1	
		50	4.5	3.8	3.1	2.7	1.8	
SND	3/4	30	15.0	13.0	11.6	8.7	6.9	70
		40	12.5	11.4	10.1	8.2	6.8	
		50	8.0	6.8	6.1	4.8	3.5	
SNE	1	30	21.4	19.1	16.5	13.3	9.5	67
		40	20.8	18.7	15.8	13.2	9.3	
		50	13.5	11.6	10.1	7.4	2.4	
SNF	1-1/2	30	28.5	25.0	21.4	17.4	12.6	67
		40	28.3	24.4	21.0	17.2	12.3	
		50	21.5	18.3	10.9	3.1	1.6	

Pump will operate at all depths shown, with pressure switch set at 30-50 PSI.

Tested and rated in accordance with Water Systems Council Standards.

NOTE: Pumps installed with a Pro-Source® tank require a 100 PSI relief valve.

Pumps installed with a conventional tank require a 75 PSI relief valve.

Relief valve must be capable of relieving entire flow of pump at relief pressure.

# ProJet™ SN Series

Cast iron, self-priming shallow well jet pumps

## OUTLINE DIMENSIONS

CATALOG NUMBER	L	B
SNC	18.7	7.1
SND	18.7	7.1
SNE	21.3	7.0
SNF	22.4	8.0

SNC and SND

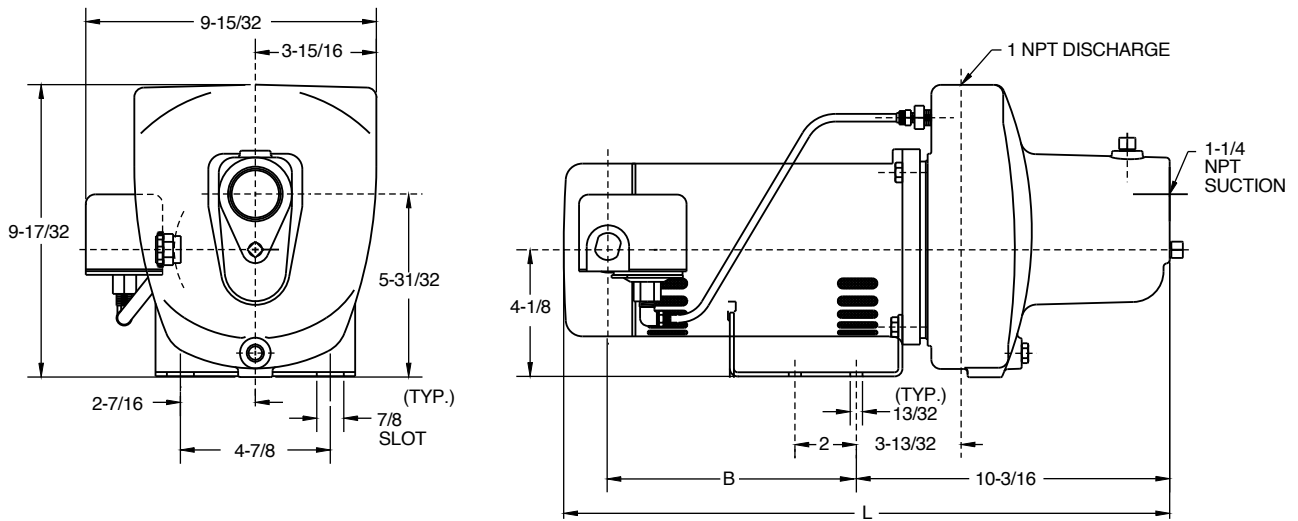

SNE and SNF

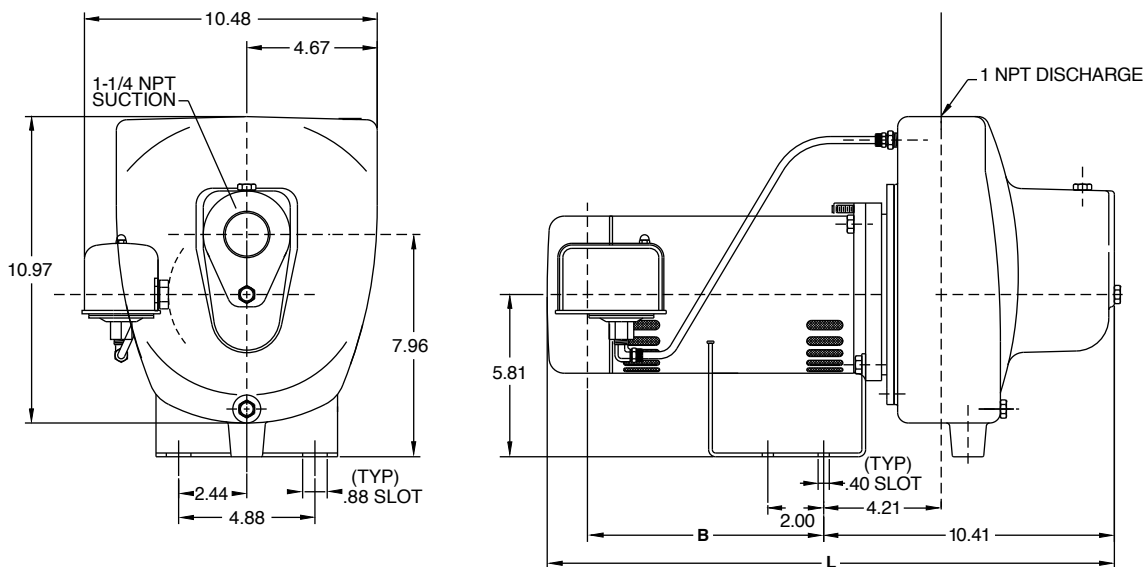

Dimensions (in inches) are for estimating purposes only.

# FN Series

Cast iron, self-priming shallow well jet pumps

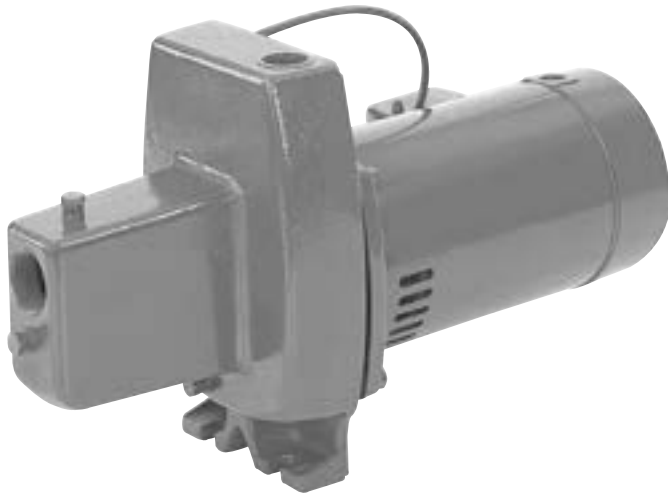

The FN Series provides strong performance with good pressure for wells to 25' deep. Self-priming after the priming chamber has been filled with water.

## APPLICATIONS

Water systems and sprinkling... for homes, farms and cottages.

## SPECIFICATIONS

### FNC Priming Time (in minutes):

at 15': 2.25 minutes max.  
at 25': 6.5 minutes max.

### FND Priming Time (in minutes):

at 15': 1.7 minutes max.  
at 25': 4.4 minutes max.

**Max. Liquid Temperature:** 140°F

**FNC Max. Inlet Pressure:** 60 PSI

**FND Max. Inlet Pressure:** 50 PSI

**Max. Inlet PSI + Pump Discharge PSI:**  
Not to exceed 100 PSI

**Body and Base:** Close-grained cast iron

**Nozzle:** High-strength polycarbonate

**Venturi:** Polycarbonate

**Impeller:** Noryl®

**Diffuser:** Reinforced polypropylene

**Shaft:** One-piece threaded stainless steel

## FEATURES

**Quality Construction:** Close-grained cast iron body and base, specially treated for corrosion resistance. Drain port provided for easy winterizing.

**Built-in Jet:** High-strength polycarbonate nozzle and venturi for maximum resistance to corrosion and abrasion. Cleanout plug provided for ease of service.

**Noryl Impeller:** Precision-molded for perfect balance...ultra-smooth for highest performance and efficiency.

**Precision-Molded Diffuser:** Pump primes faster, handles more air, with multi-port, precision-molded, reinforced polypropylene diffuser.

**Mechanical Shaft Seal:** Precision lapped and highly polished carbon-ceramic, stainless steel construction. Internal design guarantees continuous water lubrication.

**Motor Windings:** Superior insulation materials protect against excessive moisture and contaminants...assure prolonged motor life.

**Balanced Rotor:** Diecast under high pressures for uniform performance and greater efficiency, dynamically balanced.

**Heavy-Duty Ball Bearings:** Sealed, permanently lubricated bearings, extensively tested to ensure extended life and smooth, quiet operation.

**Pump and Motor Shaft:** Stainless steel for maximum corrosion resistance; one-piece threaded shaft for positive impeller drive and alignment.

**Dustproof Cover:** All electrical components are protected from dirt, dust and insects by a dustproof canopy; ventilating air cannot contaminate vital switching components.

**Pressure Switch:** Adjustable cut-in and fixed differential (20 PSI).

## ORDERING INFORMATION

CATALOG NUMBER	HP	SWITCH SETTING	DESCRIPTION	PIPE TAPPING SIZES		MOTOR VOLTAGE	APPROX. WT. LBS.
				SUCTION	DISCHARGE		
FNC	1/2	30-50	Shallow Well Jet	1-1/4"	1"	115/230	46
FND	3/4	30-50	Shallow Well Jet	1-1/4"	1"	115/230	47

# FN Series

Cast iron, self-priming shallow well jet pumps

## PUMP PERFORMANCE

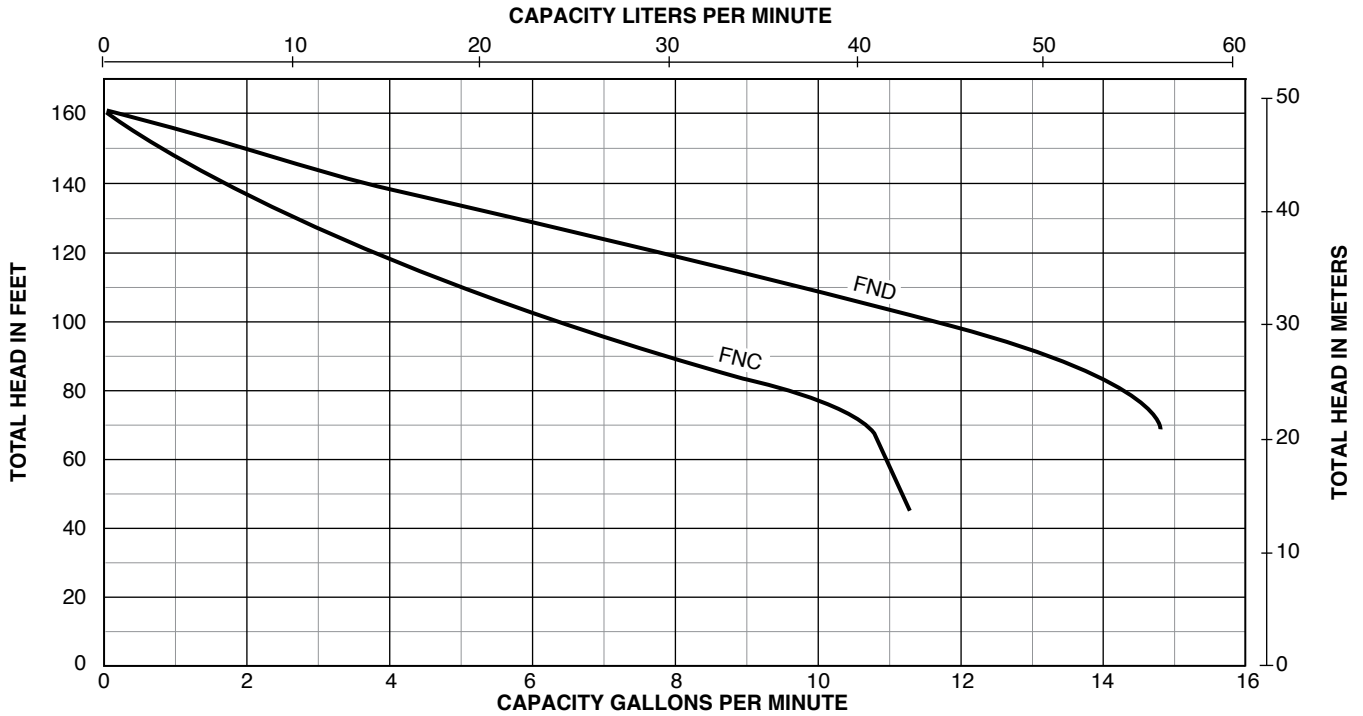

### PUMP PERFORMANCE (Capacity in gallons per minute)

CATALOG NUMBER	HP	DISCH. PRESSURE		DYNAMIC SUCTION LIFT					SHUT-OFF PRESSURE PSI
		PSI	FEET HEAD	5'	10'	15'	20'	25'	
FNC	1/2	20	46.2	9.8	8.8	7.5	6.2	4.5	69
		30	69.3	9.2	8.2	7.2	5.9	4.2	
		40	92.4	6.9	6.0	5.3	4.5	4.0	
		50	115.5	3.8	3.5	2.7	1.9	1.4	
FND	3/4	30	69.3	15.0	13.0	11.6	8.7	6.9	70
		40	92.4	12.5	11.4	10.1	8.2	6.8	
		50	115.5	8.0	6.8	6.1	4.8	3.5	

Pump will operate at all depths shown, with pressure switch set at 30-50 PSI.

Tested and rated in accordance with Water Systems Council Standards.

NOTE: Pumps installed with a Pro-Source® tank require a 100 PSI relief valve.

Pumps installed with a conventional tank require a 75 PSI relief valve.

Relief valve must be capable of relieving entire flow of pump at relief pressure.

# FN Series

Cast iron, self-priming shallow well jet pumps

## OUTLINE DIMENSIONS

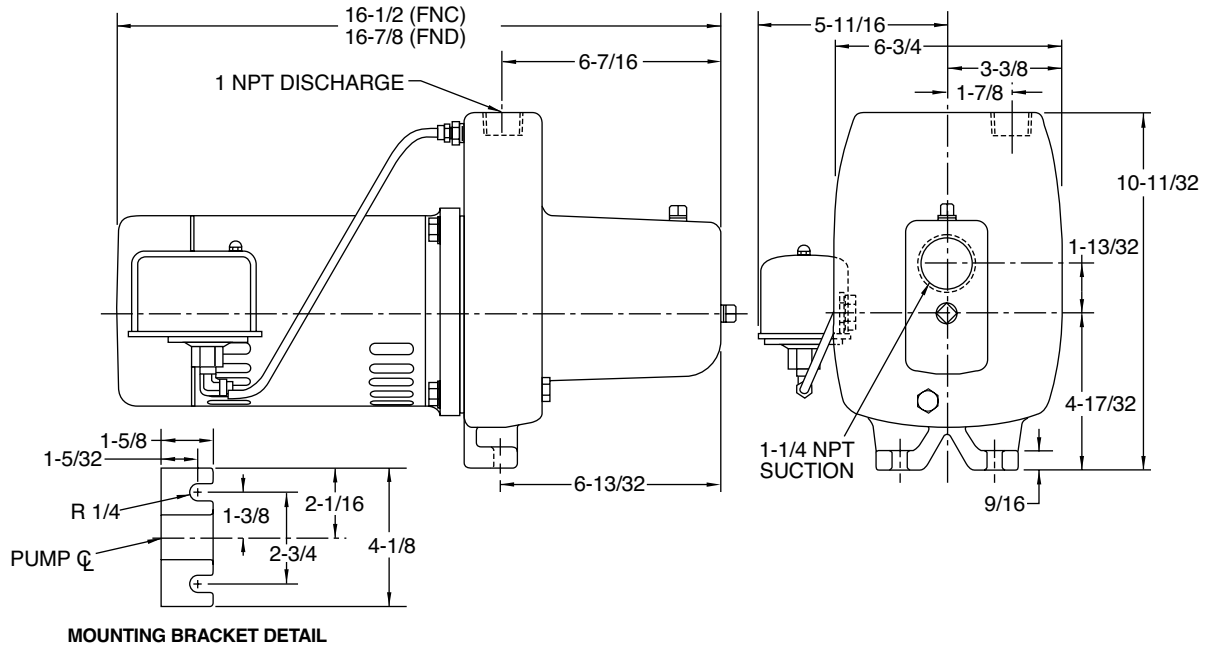

Dimensions (in inches) are for estimating purposes only.

# PN Series

Corrosion-resistant, self-priming shallow well jet pumps



PN Series Shallow Well Jet Pumps are corrosion- and abrasion-resistant and are ideal for wells with pumping levels of 25' or less.

Self-priming after the pump housing is initially filled with water.

Capacities to 18 GPM. Available in 1/2, 3/4 and 1 HP models.

Supplied with the industry standard 30-50 pressure switch setting.

## APPLICATIONS

Water Systems  
 Booster Pump  
 Marine Use  
 Mist Sprayers – Poultry  
 Fountains and Water Features

## SPECIFICATIONS

**Body and Seal Plate:** Fiberglass-reinforced thermoplastic

**Impeller:** Engineered polymer

**Base:** 12-gauge steel

**Nozzle, Venturi, Diffuser:** Polypropylene

## FEATURES

**Quality Construction:** Fiberglass-reinforced thermoplastic body provides total corrosion resistance and high resistance to abrasion.

**Built-in Jet:** Shallow-well jet has corrosion-resistant polypropylene nozzle and venturi.

**Impeller:** Precision-molded for perfect balance...ultra-smooth for highest performance and efficiency.

**Precision-Molded Diffuser:** Polypropylene diffuser allows pump to prime faster, handle more air.

**Heavy-Duty Motor:** Stainless steel shaft and dual heavy-duty ball bearings.

**Heavy-Duty Ball Bearings:** Shielded, permanently lubricated bearings, extensively tested to ensure extended life and smooth, quiet operation.

**Dual Voltage Capability:** Dual voltage motors are shipped at the 230-volt setting.

**Professional Quality, Pre-set 30-50 PSI:** Allows for cut-in pressure adjustments.

**New Nozzle Cleanout:** Easy plug removal and access for ease of service.

**New Drain Plug:** Bottom-mounted for easy draining and winterization.

## ORDERING INFORMATION

CATALOG NUMBER	HP	DESCRIPTION	PIPE TAPPING SIZES		MOTOR VOLTAGE	APPROX. WT. LBS./KG
			SUCTION	DISCHARGE		
PNC	1/2	Shallow Well Jet	1-1/4"	1"	115/230	21/9.5
PND	3/4	Shallow Well Jet	1-1/4"	1"	115/230	24/11
PNE	1	Shallow Well Jet	1-1/4"	1"	115/230	26/12

# PN Series

Corrosion-resistant, self-priming shallow well jet pumps

## PUMP PERFORMANCE: 10 GPM

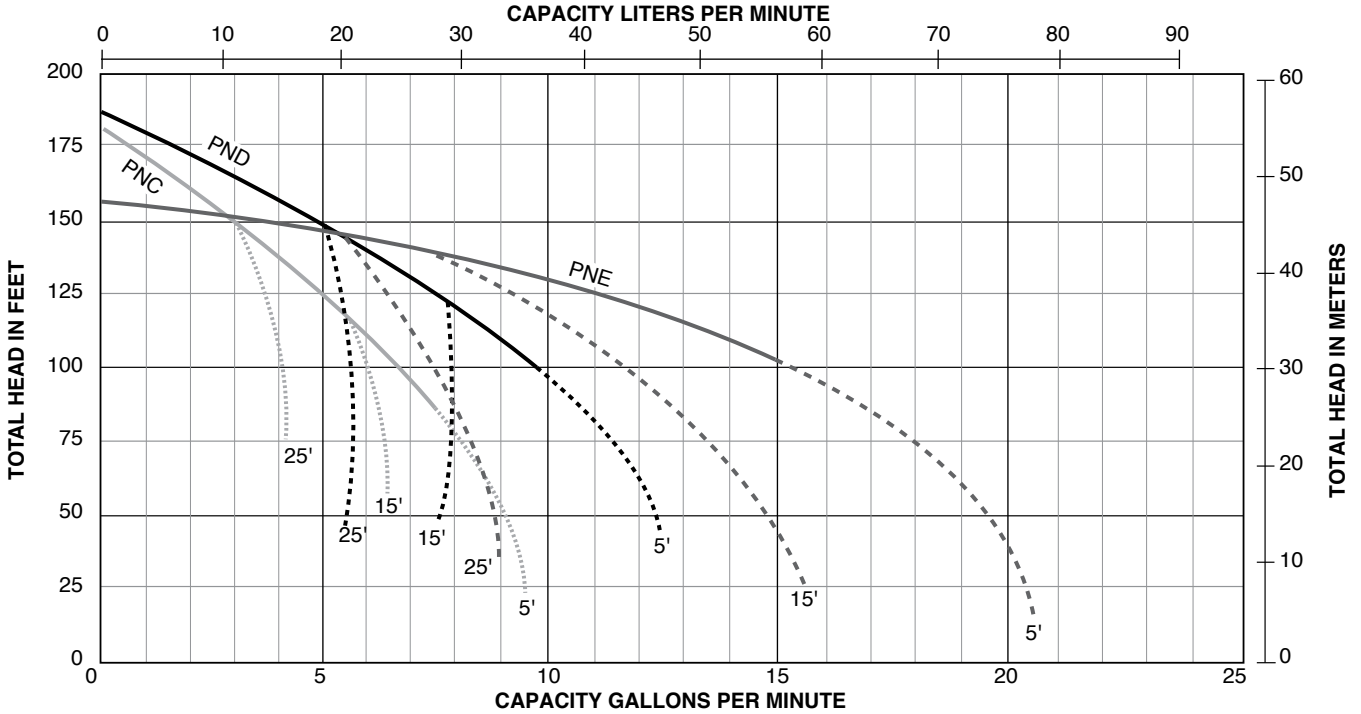

## PUMP PERFORMANCE (Capacity in gallons per minute)

CATALOG NUMBER	HP	DISCH. PRESSURE PSI	DYNAMIC SUCTION LIFT					SHUT-OFF PRESSURE PSI
			5'	10'	15'	20'	25'	
PNC	1/2	30	8.5	7.1	6.5	5.4	4.1	77
		40	7.4	6.4	6.1	5.1	4.0	
		50	5.2	5.1	4.5	4.1	3.4	
PND	3/4	30	12.1	10.7	9.0	7.6	5.3	78
		40	10.7	10.2	8.5	7.3	5.7	
		50	8.5	8.4	8.1	7.1	5.1	
PNE	1	30	18.0	17.1	14.9	12.6	8.8	67
		40	16.8	16.1	14.4	12.2	8.5	
		50	13.5	13.4	13.0	12.0	8.1	

Pumps will operate at all depths shown, with pressure switch set at 30-50 PSI. Tested and rated in accordance with Water Systems Council Standards.

NOTE: Pumps installed with a Pro-Source® tank require a 100 PSI relief valve.  
 Pumps installed with a conventional tank require a 75 PSI relief valve.  
 Relief valve must be capable of relieving entire flow of pump at relief pressure.

# PN Series

Corrosion-resistant, self-priming shallow well jet pumps

## OUTLINE DIMENSIONS

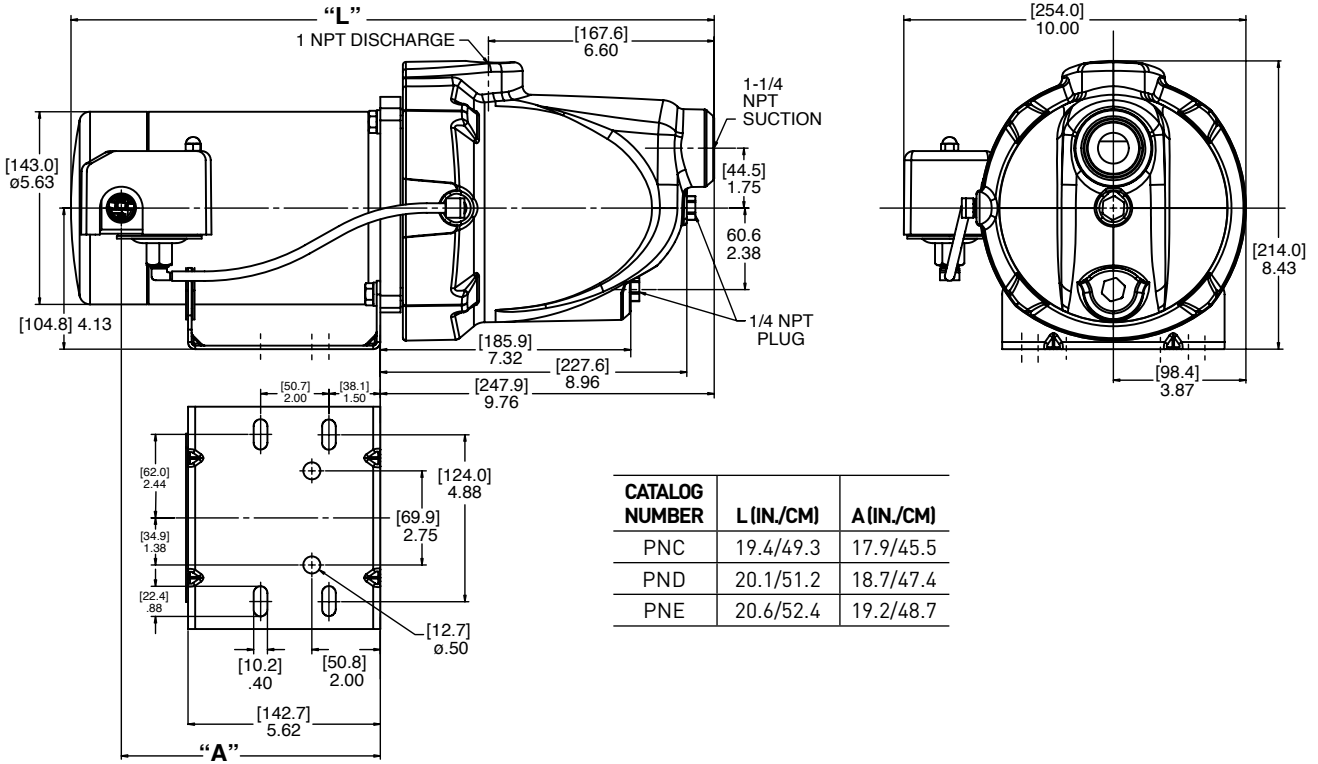

Dimensions (in inches) are for estimating purposes only.

# FH Series

Cast iron, shallow well jet pumps



The FH Series Jet Pump provides best-in-class performance for shallow wells up to 25' deep and flows over 20 GPM. Designed for the professional with heavy-duty cast iron construction, Noryl<sup>®</sup> internals and factory wired pressure switch for years of extended service. Available in 1/2 HP model.

## APPLICATIONS

Ideal for homes, farms and cottages.

## SPECIFICATIONS

**Pump Case:** Cast iron

**Diffuser:** Reinforced Polypropylene

**Seal Plate:** Cast iron

**Impeller:** Noryl<sup>®</sup>

**Mechanical Shaft Seal, Type 6:**

Buna-N, Carbon, Ceramic,  
18-8 stainless steel

**Nozzle:** Acetal

**Venturi Tube:** Acetal

**1/4" NPT Pipe Plug:** Zinc plated steel

**Mounting Base:** Steel

## FEATURES

**Precision Molded Noryl<sup>®</sup> Impeller with 300 grade Stainless Insert:** High performance and efficiency with high strength for longevity.

**Precision Molded Reinforced Polypropylene Diffuser, Nozzle and Venturi:** High performance and efficiency with superior abrasion resistance.

**Cast Iron Pump Case with 1-1/4" Suction and 1" Discharge Ports, Two 1/4" Auxiliary Pressure Ports and Cleanout Plug:** Facilitates plumbing of accessories and easy access to nozzle for cleanout.

**Rugged Cast Iron Seal Plate:** Positive alignment between pump case and motor.

**Factory Installed Pressure Switch with Fixed 20 lb. Differential and 1/4" FNPT Port:** Industry standard switch is easily field replaceable.

**Every Pump Unit is Factory Tested:** Peace of mind for you and your customers.

## ORDERING INFORMATION

Catalog Number	HP	Length	Approx. Wt. Lbs.
FH50	1/2	18-5/8	40

This product is Listed to UL and CSA Standards for Safety by CSA International.

Pentair trademarks and logos are owned by Pentair plc or its affiliates. All other third party registered and unregistered trademarks and logos are the property of their respective owners.

# FH Series

Cast iron, shallow well jet pumps

## PUMP PERFORMANCE

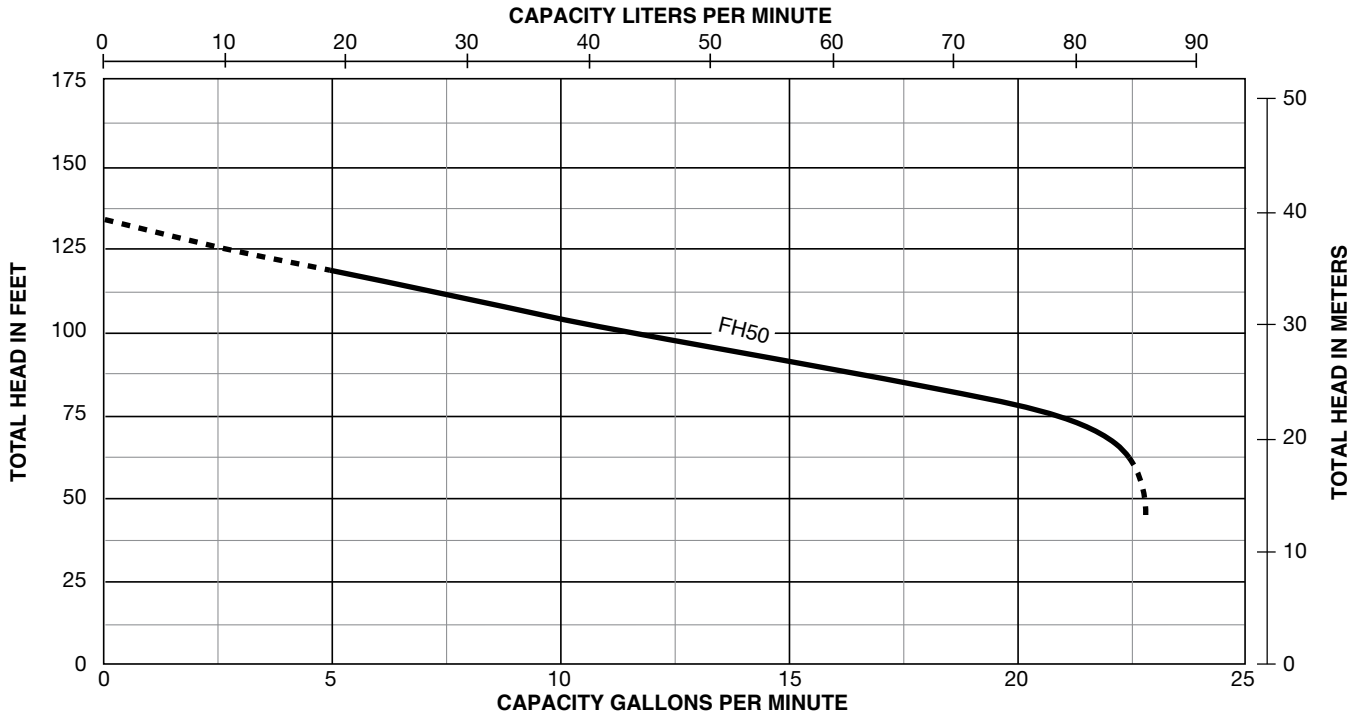

## PUMP PERFORMANCE

HP	Catalog Number	Total Suction Lift - Ft.	Discharge Pressure - PSI								Shut Off PSI	
			20	25	30	35	40	45	50	55		60
1/2	FH50	5	22.5	22.4	22.0	20.6	16.4	12.0	8.0	4.4	—	61.0
		10	19.5	19.3	19.0	17.8	14.5	10.4	6.5	2.8	—	58.8
		15	16.6	16.3	16.0	15.3	13.3	9.0	5.2	1.4	—	56.7
		20	14.0	13.8	13.6	13.2	11.4	7.3	3.5	—	—	54.5
		25	11.4	11.4	11.3	11.2	9.8	5.8	2.0	—	—	52.4

Pumping capacities in gallons per minute at indicated discharge pressures in pounds per square inch.

# FH Series

Cast iron, shallow well jet pumps

**OUTLINE DIMENSIONS**

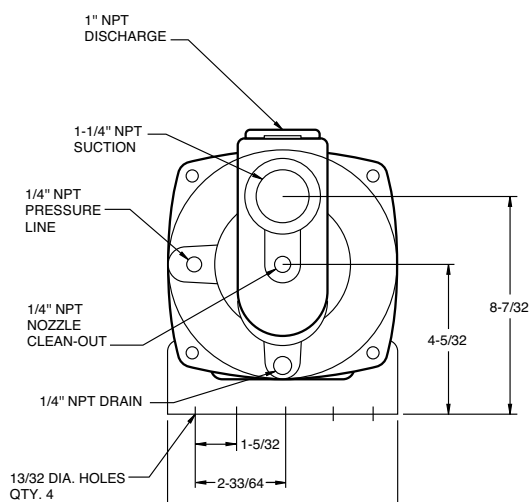
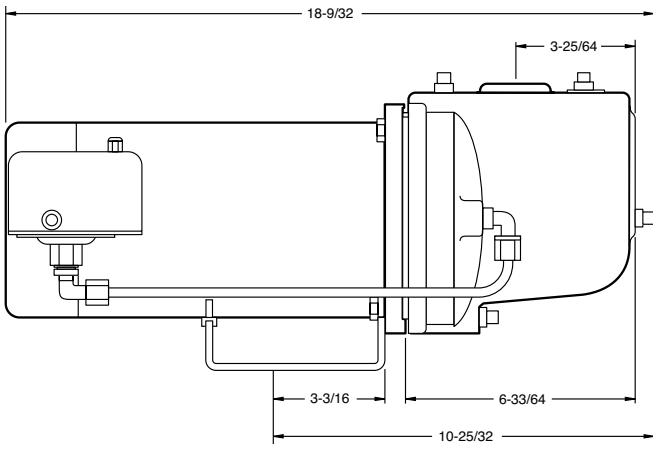

Dimensions (in inches) are for estimating purposes only.

# Pro-Source® Jet/Tank Packages

Cast Iron

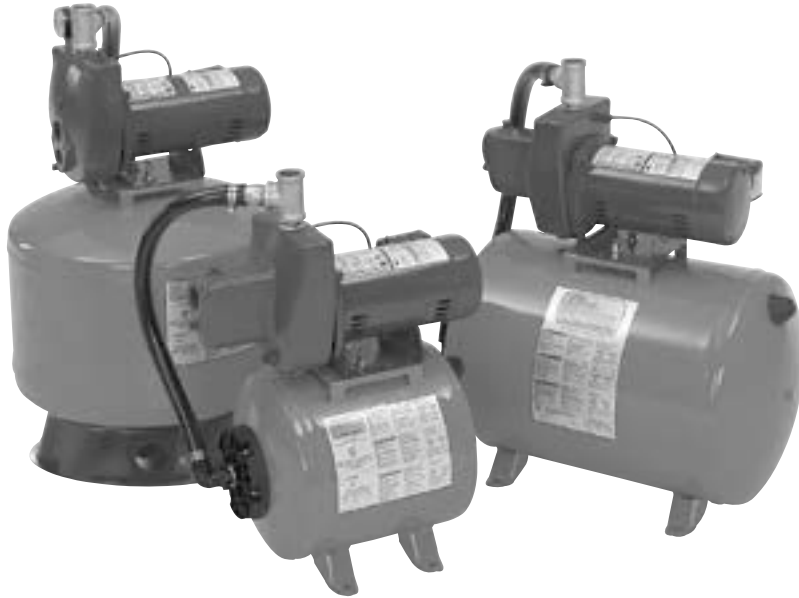

Pro-Source™ Water System Packages are handy and economical pump/tank packages for the professional contractor. The Pro-Source Water System Packages utilize the ProJet™ cast iron jet pumps and the dependable

Pro-Source quality pressurized steel tanks. Plumbing connections are made using galvanized fittings and 3-ply nylon reinforced vinyl tubing with stainless steel hose clamps. Ideal for installations where there is limited space.

## APPLICATIONS

Water systems, sprinkling and pressure boosting...for homes, farms and cottages.

## SPECIFICATIONS

**Max. Liquid Temperature:**

120°F (49°C)

**Max. Inlet Pressure:** 50 PSI

**Pump Discharge PSI:** Not to exceed 100 PSI

## FEATURES

### ProJet™ Jet Pumps

**Body:** Close-grained cast iron

**Nozzle:** High-strength polycarbonate

**Venturi:** Polycarbonate

**Impeller:** Noryl®

**Diffuser:** Reinforced polypropylene

**Shaft:** 416 stainless steel

**Base:** Steel, 10 gauge

### Pro-Source™ Pressurized Tanks

**Shell:** Heavy-gauge steel

**Base:** High-impact composite; polypropylene

**Finish:** Baked-on polyester paint

**Water Cell:** PVC made from FDA listed material

**Flange:** Reinforced polypropylene

**Connections:** Galvanized

**Tubing:** 3-ply nylon reinforced vinyl with stainless steel hose clamps

## ORDERING INFORMATION

JET/TANK CATALOG NUMBER	HP	JET PUMP TYPE	PUMP CAT. NO.	TANK CAT. NO.	TANK STYLE	TANK CAPACITY U.S. GAL.	DRAWDOWN @ 30-50 PSI SWITCH SET.	CONNECTION SIZE FEMALE	APPROX. WT. LBS.
SNCP15H	1/2	Shallow Well	SNC	PS6H-S05	Horizontal	6	1.8	3/4" NPT	85
SNCP42H	1/2	Shallow Well	SNC	PS19H-S00	Horizontal	19	5.8	1" NPT	95
SNCP42	1/2	Shallow Well	SNC	PS19S-T02	Vertical	19	5.8	1" NPT	120
SLCP42*	1/2	Deep Well	SLC	PS19S-T02	Vertical	19	5.8	1" NPT	127
SLDP42*	3/4	Deep Well	SLD	PS19S-T02	Vertical	19	5.8	1" NPT	130

\*Shallow well/deep well Jet Package included.

Pentair trademarks and logos are owned by Pentair plc or its affiliates. All other third party registered and unregistered trademarks and logos are the property of their respective owners.

# Pro-Source® Jet/Tank Packages

Cast Iron

## PUMP PERFORMANCE

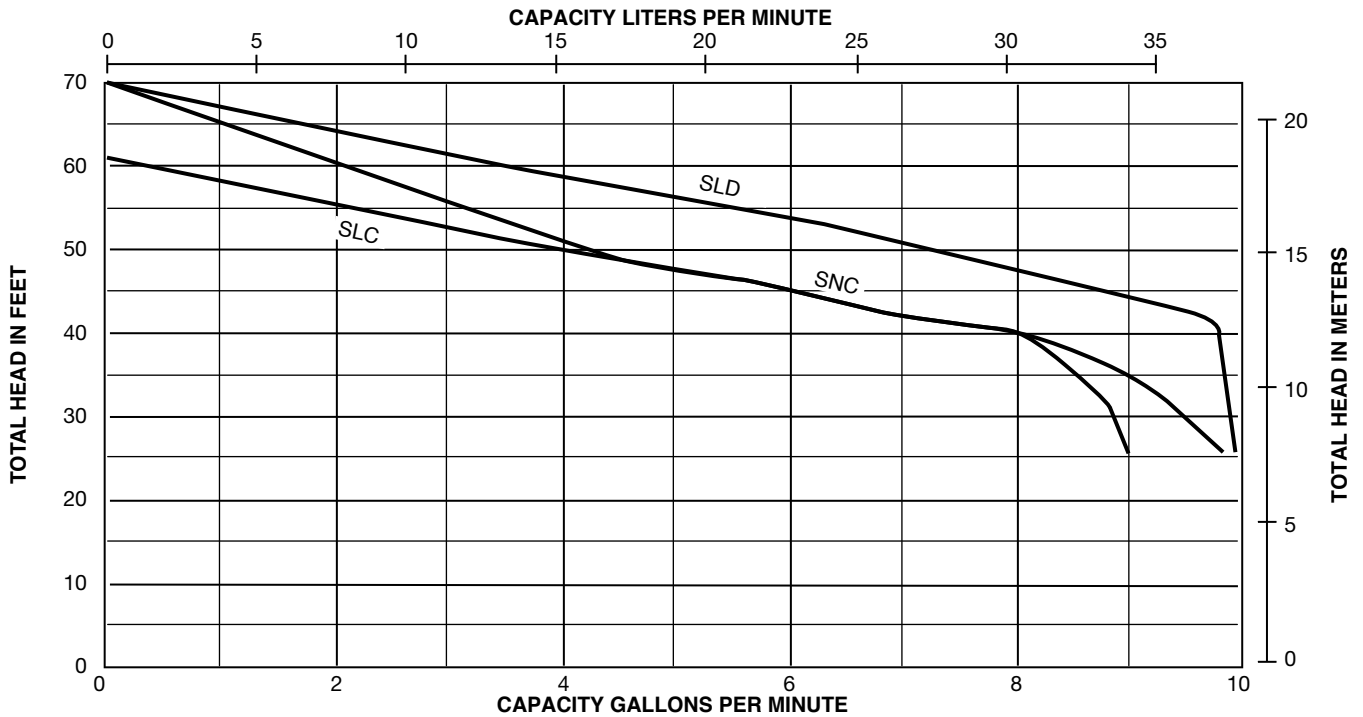

### TANK DRAWDOWN (In gallons)

TANK CATALOG NUMBER	PRESSURE SWITCH SETTING		
	20-40	30-50	40-60
PS6H-S05	2.2	1.8	1.6
PS19S-T02	6.9	5.8	5.0
PS19H-S00	6.9	5.8	5.0

### SHALLOW WELL PUMP PERFORMANCE (Capacity in gallons per minute)

CATALOG NUMBER	HP	TOTAL SUCTION LIFT	DISCHARGE PRESSURE (PSI)			SHUT-OFF PSI
			30	40	50	
SNC	1/2	5'	9.7	7.9	4.5	67
		10'	8.3	7.2	3.8	65
		15'	7.4	6.4	3.1	62
		20'	5.9	5.6	2.7	60
		25'	4.3	4.1	1.8	58

NOTE: Pump will operate at all depths shown, with pressure switch set at 30-50 PSI.  
Pumps installed with Pro-Source® tank require a 100 PSI relief valve.

### PUMP PERFORMANCE (Capacity in gallons per minute)

CATALOG NUMBER	HP	USE VENTURI/NOZZLE	EJECTOR PKG.*	SHALLOW WELL JET COMBINATIONS					SHUT-OFF PSI		
				TOTAL SUCTION LIFT	DISCHARGE PRESSURE (PSI)						
					30	40	50	60			
SLC	1/2	N32P-66B J34P-41	29SD	5'	9.0	7.9	4.1	-	61		
				15'	7.2	6.3	3.3	-	56		
				25'	4.7	4.1	2.1	-	52		
SLD	3/4	N32P-66B J34P-41	29SD	5'	9.9	9.8	7.3	3.5	70		
				15'	7.9	7.8	5.8	2.8	64		
				25'	5.1	5.0	3.8	1.7	59		
CATALOG NUMBER	HP	USE VENTURI/NOZZLE	EJECTOR PKG.*	DEEP WELL JET COMBINATIONS							
				DISCHARGE PRESSURE PSI	DISCHARGE PRESSURE (PSI)					SHUT-OFF MIN. DEPTH	
					30	40	50	60	70		80
SLC	1/2	J32P-24 J34P-41	4SD	30	7.3	5.8	4.5	3.3	2.3	-	68
				40	4.5	3.4	2.3	-	-	-	-
SLD	3/4	J32P-24 J34P-41	4SD	30	8.9	7.3	6.4	5.0	4.0	2.5	75
				40	6.5	5.1	4.0	3.0	1.8	0.8	-

# Pro-Source® Jet/Tank Packages

Cast Iron

## OUTLINE DIMENSIONS: SHALLOW WELL

SNCP15H

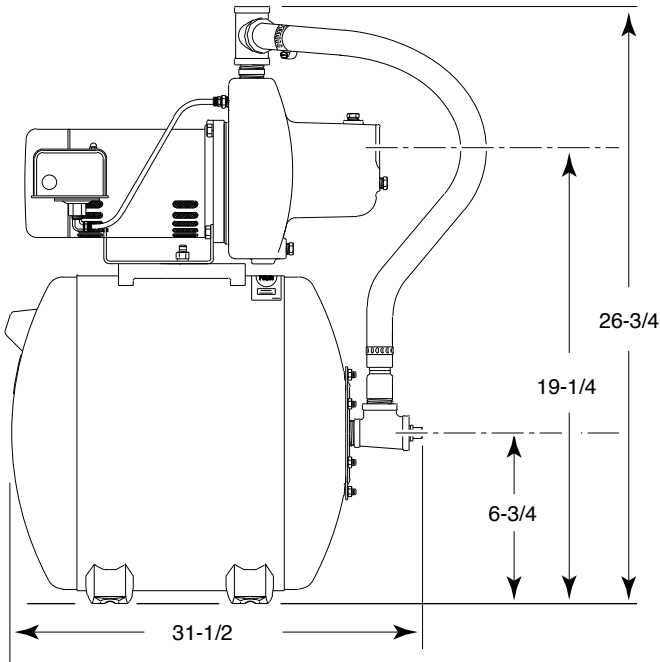

## OUTLINE DIMENSIONS: DEEP WELL

SLCP42, SLDP42

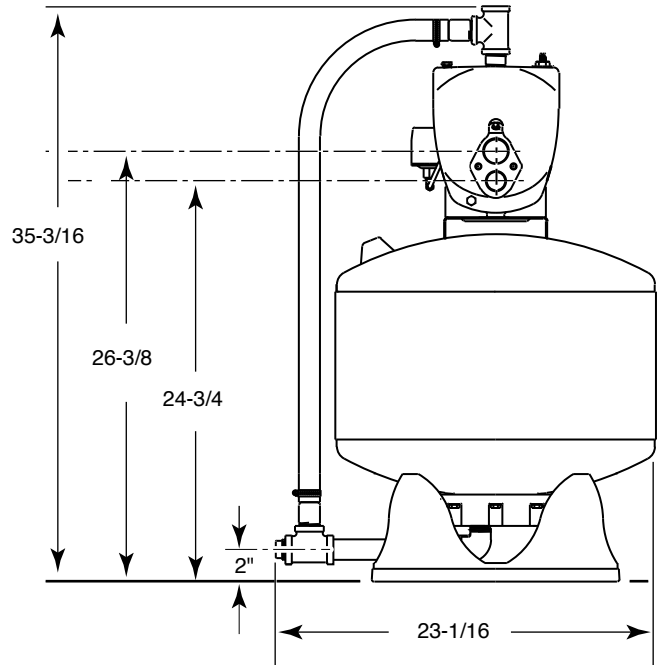

SNCP42

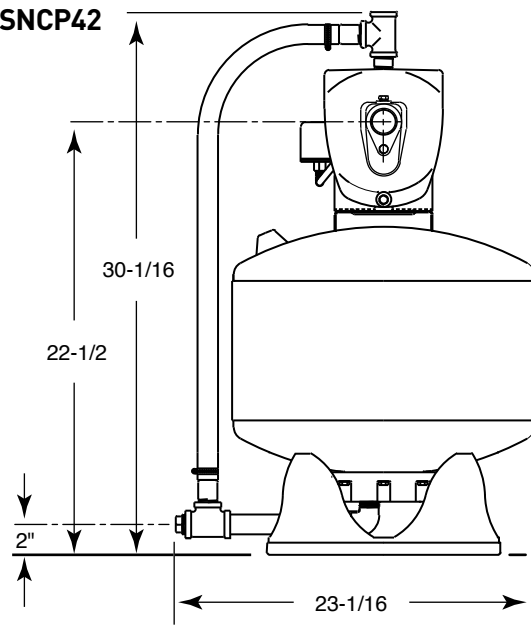

SNCP42H

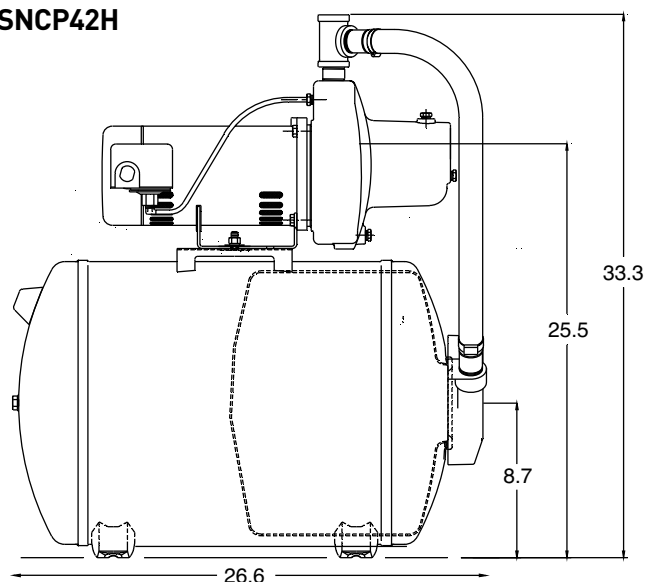

Dimensions (in inches) are for estimating purposes only.

# ProJet™ HL Series

Cast iron, self-priming convertible jet pumps

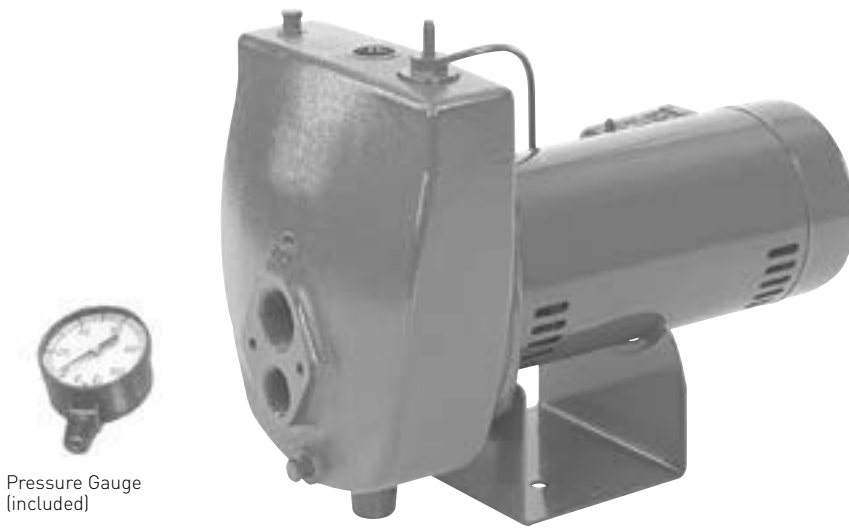

Pressure Gauge (included)



The ProJet HL convertible jet pumps offer a proven cast iron self-priming design available in 1/2 – 1 HP models. The ProJet HL convertible jets utilize built-in regulators offering easier priming and better range of performance from a complete line of shallow well, 4" double pipe, 2" and 3" single pipe jet packages.

## APPLICATIONS

Water systems and sprinkling... for homes, farms and cottages.

## SPECIFICATIONS

**Body and Seal Plate:** Close-grained cast iron

**Impeller:** High-strength Noryl®

**Diffuser:** Reinforced polypropylene with brass wear ring

**Shaft:** One-piece threaded 416 stainless steel

**Base:** Steel, 12 gauge

**Max. Liquid Temperature:** 140°F

**Max. Inlet Pressure:** 50 PSI

**Pressure Switch Pre-Set:** 30-50 PSI

**Suction Ports:** "Suction-over-Drive"

**Pressure Gauge:** 0-100 PSI

## FEATURES

**Quality Construction:** Close-grained cast iron pump body is a rugged one-piece unit, specially treated to resist corrosion. Drain port provided for easy winterizing.

**Noryl Impeller:** Precision-molded for perfect balance...ultra-smooth for highest performance and efficiency.

**Precision-Molded Diffuser:** Pump primes faster, handles more air, with multi-port, precision-molded, reinforced polypropylene diffuser.

**Pressure Switch:** High quality, cut-in and differential pressure setting are adjustable.

**Mechanical Shaft Seal:** Precision lapped and highly polished carbon-ceramic, stainless steel construction. Internal design guarantees continuous water lubrication for maximum protection.

**Motor Windings:** Superior insulation materials protect against excessive moisture and contaminants...assures prolonged motor life.

**Balanced Rotor:** Diecast under high pressures for uniform performance and greater efficiency...dynamically balanced.

**Heavy-Duty Ball Bearings:** Shielded, permanently lubricated bearings, extensively tested to ensure extended life and smooth, quiet operation.

**Pump and Motor Shaft:** 416 stainless steel for maximum corrosion resistance; one-piece threaded shaft for positive impeller drive and alignment.

## ORDERING INFORMATION

CATALOG NUMBER	HP	DESCRIPTION	PIPE TAPPING SIZES			MOTOR VOLTAGE	APPROX. WT. LBS.
			SUCTION	DRIVE	DISCHARGE		
HLC	1/2	Deep Well Jet	1-1/4"	1"	1"	115/230	42
HLD	3/4	Deep Well Jet	1-1/4"	1"	1"	115/230	60
HLE	1	Deep Well Jet	1-1/4"	1"	1"	115/230	65

A Jet Package should be ordered with every Series HL Pump.

NOTE: Pumps installed with a Pro-Source® tank require a 100 PSI relief valve. Pumps installed with a conventional tank require a 75 PSI relief valve. Relief valve must be capable of relieving flow of pump at relief pressure.

Pentair trademarks and logos are owned by Pentair plc or its affiliates. All other third party registered and unregistered trademarks and logos are the property of their respective owners.

# ProJet™ HL Series

Cast iron, self-priming convertible jet pumps

## OUTLINE DIMENSIONS

CATALOG NUMBER	HP	A	B
HLC	1/2	14.25	7.09

HLC

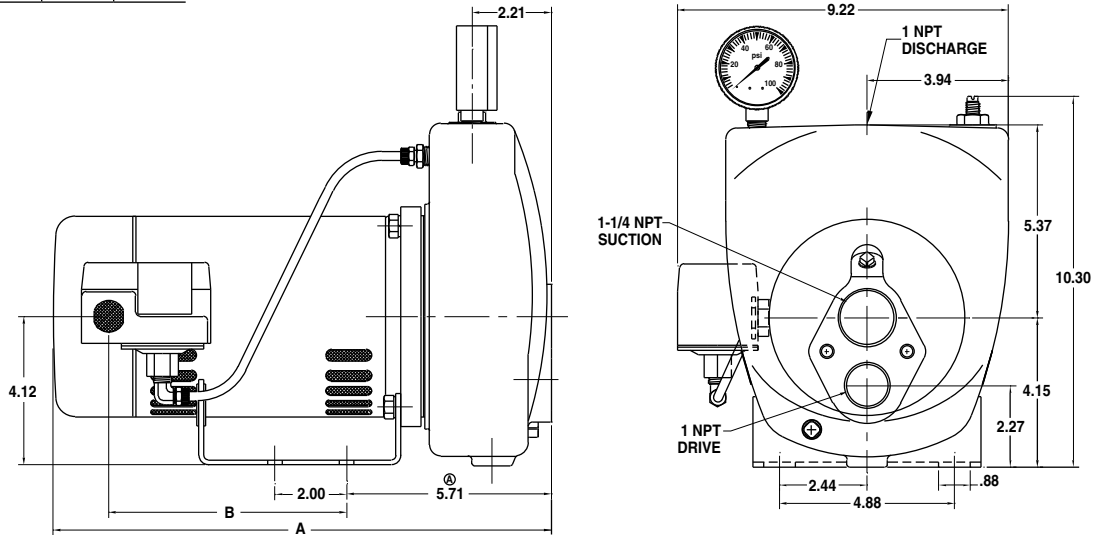

CATALOG NUMBER	HP	A	B
HLD	3/4	15.79	8.03
HLE	1	17.91	9.09

HLD and HLE

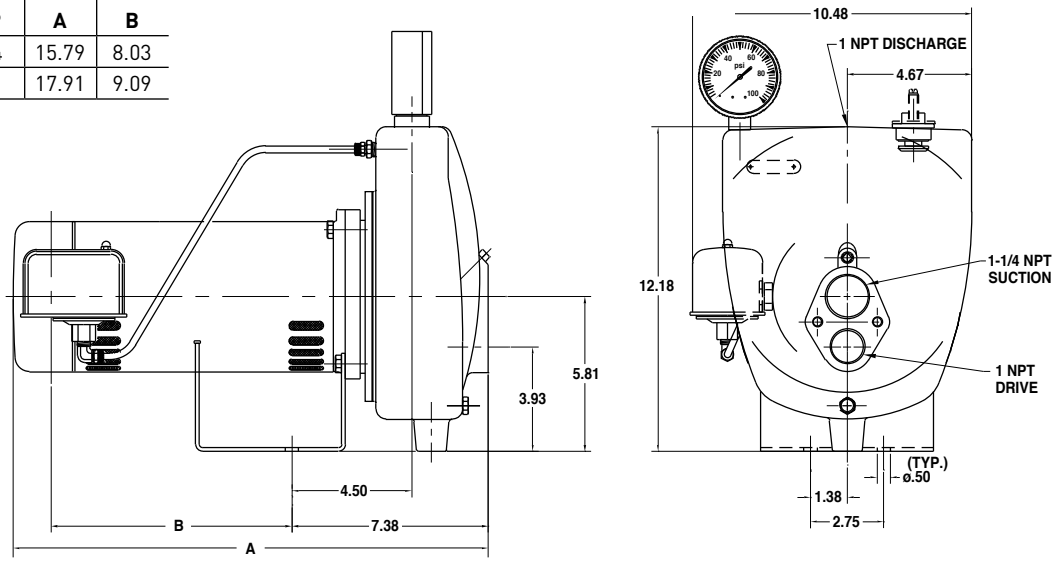

Dimensions (in inches) are for estimating purposes only.

NOTE: 1/4 NPT, 0-100 PSI pressure gauge supplied uninstalled to prevent shipping damage.

# ProJet™ HL Series

Cast iron, self-priming convertible jet pumps

**PUMP PERFORMANCE** (Capacity in gallons per minute)  
**SHALLOW WELL – 5', 10', 15', 20' AND 25' PUMPING DEPTHS**

CAT. NO.	HP	DISCH. PRESS.	PUMPING DEPTH TO WATER IN FEET																								
			5 FT. LIFT				10 FT. LIFT				15 FT. LIFT				20 FT. LIFT				25 FT. LIFT								
HLC	1/2	<b>JET PACKAGE</b>	11SD	10SD	29SD	CK5	11SD	10SD	29SD	CK5	11SD	10SD	29SD	CK5	11SD	10SD	29SD	CK5	11SD	10SD	29SD	CK5					
		Venturi N32P-	-68B	-67B	-66B	-66B	-68B	-67B	-66B	-66B	-68B	-67B	-66B	-66B	-68B	-67B	-66B	-66B	-68B	-67B	-66B	-66B					
		Nozzle J43P-	-44	-44	-41	-45	-44	-44	-41	-45	-44	-44	-41	-45	-44	-44	-41	-45	-44	-44	-41	-45					
		20 PSI	20.6	14.4	10.1	6.6	19.0	13.2	9.3	6.1	16.5	11.5	8.1	5.3	13.3	9.5	6.9	4.5	9.8	6.9	5.3	3.4					
		30 PSI	19.6	14.3	9.9	6.5	18.1	13.1	9.1	6.0	15.7	11.4	7.9	5.2	13.3	9.5	6.7	4.4	9.8	6.9	5.1	3.4					
		40 PSI	10.3	12.1	9.8	6.4	9.4	11.2	9.0	5.9	8.2	9.7	7.8	5.1	6.4	8.3	6.6	4.3	3.1	6.3	5.1	3.3					
		50 PSI		4.6	7.3	6.3		4.3	6.7	5.8		3.7	5.8	5.0		2.6	4.9	4.3		1.0	3.8	3.3					
		60 PSI			3.5	5.8			3.2	5.3			2.8	4.6			2.4	3.9				3.0					
		Shut-off-PSI	55	59	70	72	53	57	66	67	50	55	64	65	48	53	61	63	46	51	59	61					
HLD	3/4	<b>JET PACKAGE</b>	12SD	11SD	CK1	CK5	CK1	12SD	11SD	CK1	CK5	CK1	12SD	11SD	CK1	CK5	CK1	12SD	11SD	CK1	CK5	CK1	12SD	11SD	CK1	CK5	CK1
		Venturi N32P-	-65	-68B	-72E	-67B	-72	-65	-68B	-72E	-67B	-72	-65	-68B	-72E	-67B	-72	-65	-68B	-72E	-67B	-72	-65	-68B	-72E	-67B	-72
		Nozzle J34P-	-44	-44	-43	-45	-43	-44	-44	-43	-45	-43	-44	-44	-43	-45	-43	-44	-44	-43	-45	-43	-44	-44	-43	-45	-43
		20 PSI	24.2	20.3	14.5	12.6	8.6	23.2	19.4	13.9	12.1	8.3	20.2	16.9	12.1	10.5	7.2	17.7	13.6	10.3	8.2	6.1	12.5	10.4	7.9	6.2	4.7
		30 PSI	24.0	20.3	14.4	12.4	8.5	23.0	19.4	13.8	11.8	8.2	20.0	16.9	12.0	10.3	7.1	17.7	13.6	10.2	8.0	6.0	12.5	10.4	7.8	6.0	4.6
		40 PSI	16.7	16.4	13.7	12.2	8.3	16.0	15.8	13.1	11.7	7.9	13.9	13.7	11.4	10.2	6.9	16.0	11.5	9.7	7.8	5.9	10.3	8.3	7.4	5.8	4.5
		50 PSI			12.6	12.0	8.2			12.1	11.5	7.8			10.5	10.0	6.8			8.9	7.7	5.8			6.8	5.7	4.4
		60 PSI			6.0	8.2	6.1			5.8	7.8	5.9			5.0	6.8	5.1			4.3	5.8	4.3			3.3	4.8	3.3
		70 PSI				4.2	2.9				4.0	2.8				3.5	2.4				2.8	2.0				2.0	1.6
Shut-off-PSI	61	62	71	80	82	59	60	69	78	79	57	58	67	76	77	54	55	65	74	75	52	53	63	72	73		
HLE	1	<b>JET PACKAGE</b>	12SD	CK2	60SD	12SD	CK2	60SD	12SD	CK2	60SD	12SD	CK2	60SD	12SD	CK2	60SD	12SD	CK2	60SD	12SD	CK2	60SD				
		Venturi N32P-	-65	-64	-64	-65	-64	-64	-65	-64	-64	-65	-64	-64	-65	-64	-64	-65	-64	-64	-65	-64	-64				
		Nozzle J34P-	-44	-44	-45	-44	-44	-45	-44	-44	-45	-44	-44	-45	-44	-44	-45	-44	-44	-45	-44	-44	-45				
		20 PSI	26.8	21.6	18.4	24.6	19.9	16.9	21.4	17.3	14.7	18.2	14.7	12.5	13.9	11.2	9.6										
		30 PSI	26.5	21.5	18.1	24.4	19.8	16.7	21.2	17.2	14.5	18.0	14.6	12.3	13.8	11.2	9.4										
		40 PSI	22.9	21.3	17.5	21.0	19.6	16.1	18.3	17.0	14.0	15.6	14.5	11.9	11.9	11.1	9.1										
		50 PSI	15.1	16.8	17.3	13.9	15.4	15.9	12.1	13.4	13.8	10.3	11.4	11.7	7.9	8.7	9.0										
		60 PSI		4.0	15.6		3.7	14.4		3.2	12.5		2.7	10.6		2.1	8.1										
		70 PSI			4.1			3.8			3.3			2.8													
Shut-off-PSI	61	71	77	59	69	75	57	67	73	55	65	71	53	63	68												

NOTE: Pumps are supplied with 30-50 pressure switch setting. Cut-in/Cut-out pressure settings are adjustable.

# ProJet™ HL Series

Cast iron, self-priming convertible jet pumps

**PUMP PERFORMANCE** (Capacity in gallons per minute)  
**DEEP WELL (40 PSI) 4" DOUBLE PIPE**

CAT. NO.	HP	JET NO.	USES VENTURI	USES NOZZLE	PUMPING DEPTH IN FEET										MAX. PUMP SHUT-OFF PRESSURE PSI			
					20'	30'	40'	50'	60'	70'	80'	90'	100'	110'	120'	JET AT 20 FT. DEPTH	JET AT MAX. DEPTH	
HLC	1/2	CK3	J32P-26	J34P-41	9.4	8.0	6.6										77	68
		54SD	J32P-22	J34P-44	8.0	6.9	5.7	4.8	3.8	3.2							94	70
		CK5	N32P-66B	J34P-45	7.3	6.2	5.0	4.0									83	69
		55SD	J32P-18	J34P-43	5.0	4.3	3.7	3.2	2.6	2.2	1.8	1.5					96	63
HLD	3/4	CK1	N32P-72	J34P-43	13.2	10.8	8.4	6.3	4.2								74	56
		CK2	J32P-24	J34P-44	13.0	11.5	9.9	8.7	7.5	6.6	5.4						105	80
		54SD	J32P-22	J34P-44	8.2	7.7	6.7	6.3	5.8	5.4	4.8	4.0	3.7	3.4	2.7		122	73
HLE	1	54SD	J32P-22	J34P-44	9.5	8.5	7.4	6.9	6.5	6.0	5.4	4.8	4.2	3.6	2.9		127	76

NOTE: Tank body on HLE pump tapped 1-1/4" x 1". On HLE pump, drop pipe should be increased to 1-1/2" x 1-1/4" to ensure adequate capacity from pump.

**PUMP PERFORMANCE** (Capacity in gallons per minute)  
**DEEP WELL (40 PSI) 2" SINGLE PIPE**

CAT. NO.	HP	JET NO.	USES VENTURI	USES NOZZLE	PUMPING DEPTH IN FEET										MAX. PUMP SHUT-OFF PRESSURE PSI			
					20'	30'	40'	50'	60'	70'	80'	90'	100'	110'	120'	JET AT 20 FT. DEPTH	JET AT MAX. DEPTH	
HLC	1/2	54AP	J32P-22	J34P-44	7.4	6.3	5.2	3.9	2.5	2.0							82	54
HLD	3/4	10AP	J32P-24	J34P-44	10.5	10.0	8.1	6.2									96	79
		54AP	J32P-22	J34P-44	6.0	5.3	4.8	4.2	4.1	3.7	3.5	2.8	2.1	1.6			95	53
HLE	1	9AP	J32P-29	J34P-44	11.7	11.1	9.8	6.8									69	57
		8AP	J32P-18	J34P-42	6.7	5.8	5.3	4.7	4.5	4.1	3.8	3.1	2.6	2.0	1.6		129	72

**DEEP WELL (40 PSI) 3" SINGLE PIPE**

HLC	1/2	9CP	J32P-26	J34P-41	9.4	8.0	6.6										77	68
		54CP	J32P-22	J34P-44	8.0	6.9	5.7	4.8	3.8	3.2								94
HLD	3/4	18CP	J32P-24	J34P-44	13.0	11.5	9.9	8.7	7.5	6.6	5.4						106	80
		54CP	J32P-22	J34P-44	8.5	7.7	6.7	6.3	5.8	5.4	4.8	4.0	3.7	3.4	2.7		122	73
		57CP	J32P-33	P122-108	18.0	15.4	12.8	10.8									81	68
HLE	1	54CP	J32P-22	J34P-44	9.5	8.5	7.4	6.9	6.5	6.0	5.4	4.8	4.2	3.6	2.9		127	76

Tank body on HLE pump tapped 1-1/4" x 1". Drop pipe should be increased to 1-1/2" x 1-1/4" to ensure adequate capacity from pump. Tested and rated in accordance with Water Systems Council Standards.

NOTE: Pumps installed with a Pro-Source® tank require a 100 PSI relief valve. Pumps installed with a conventional tank require a 75 PSI relief valve. Relief valve must be capable of relieving entire flow of pump at relief pressure.

# ProJet™ SL Series

Cast iron, self-priming convertible jet pumps



The ProJet SL convertible jet pumps offer a proven cast iron self-priming design available in 1/2 to 1-1/2 HP models. The ProJet SL convertible jets utilize the built-in regulators, offering easier priming and better range of performance from a complete line of shallow well, 4" double pipe, 2" and 3" single pipe jet packages.

## APPLICATIONS

Water systems and sprinkling... for homes, farms and cottages.

## SPECIFICATIONS

**Body and Seal Plate:** Close-grained cast iron

**Impeller:** High-strength Noryl®

**Diffuser:** Reinforced polypropylene with brass wear ring

**Shaft:** One-piece threaded 416 stainless steel

**Base:** Steel, 12 gauge

**Max. Liquid Temperature:** 140°F

**Max. Inlet Pressure:** 50 PSI

**Pressure Switch Pre-Set:** 30-50 PSI

**Suction Ports:** "Suction-over-Drive"

## FEATURES

**Quality Construction:** Close-grained cast iron pump body is rugged one-piece unit, specially treated to resist corrosion. Drain port provided for easy winterizing.

**Noryl Impeller:** Precision-molded for perfect balance...ultra-smooth for highest performance and efficiency.

**Precision-Molded Diffuser:** Pump primes faster, handles more air, with multi-port, precision-molded, reinforced polypropylene diffuser.

**Pressure Switch:** High-quality, cut-in pressure setting is adjustable. Fixed 20 PSI differential.

**Mechanical Shaft Seal:** Precision-lapped and highly polished carbon-ceramic, stainless steel construction. Internal design guarantees continuous water lubrication for maximum protection.

**Motor Windings:** Superior insulation materials protect against excessive moisture and contaminants...assures prolonged motor life.

**Balanced Rotor:** Diecast under high pressures for uniform performance and greater efficiency...dynamically balanced.

**Heavy-Duty Ball Bearings:** Shielded, permanently lubricated bearings, extensively tested to ensure extended life and smooth, quiet operation.

**Pump and Motor Shaft:** 416 stainless steel for maximum corrosion resistance; one-piece threaded shaft for positive impeller drive and alignment.

**Dustproof Cover:** Dustproof canopy protects all electrical components from dirt, dust and insects; ventilating air cannot contaminate vital switching components... eliminates the most common cause of motor failure.

## ORDERING INFORMATION

CATALOG NUMBER	HP	DESCRIPTION	PIPE TAPPING SIZES			MOTOR VOLTAGE	APPROX. WT. LBS.
			SUCT.	DRIVE	DISCH.		
SLC	1/2	Deep Well Jet	1-1/4"	1"	1"	115/230	40
SLD	3/4	Deep Well Jet	1-1/4"	1"	1"	115/230	42
SLE	1	Deep Well Jet	1-1/4"	1"	1"	115/230	60
SLF	1-1/2	Deep Well Jet	1-1/4"	1"	1"	115/230	65

A Jet Package should be ordered with every SL Series Pump.

NOTE: Pumps installed with a Pro-Source® tank require a 100 PSI relief valve. Pumps installed with a conventional tank require a 75 PSI relief valve. Relief valve must be capable of relieving flow of pump at relief pressure.

Pentair trademarks and logos are owned by Pentair plc or its affiliates. All other third party registered and unregistered trademarks and logos are the property of their respective owners.

# ProJet™ SL Series

Cast iron, self-priming convertible jet pumps

## OUTLINE DIMENSIONS

CATALOG NUMBER	HP	ADIM.	B DIM.
SLC	1/2	13.62	6.46
SLD	3/4	14.25	7.09

SLC and SLD

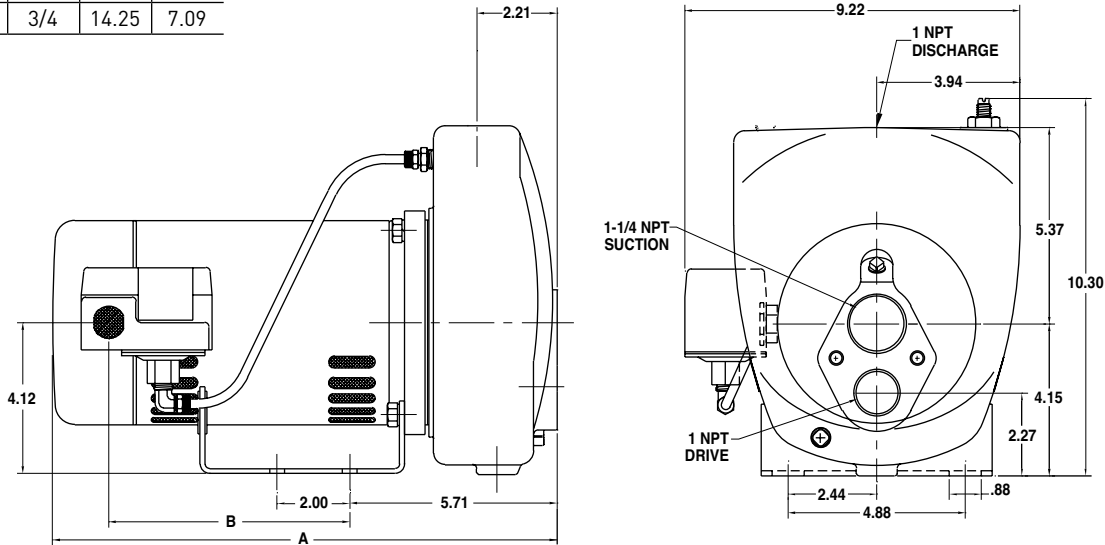

CATALOG NUMBER	HP	ADIM.	B DIM.
SLE	1	15.79	8.03
SLF	1-1/2	17.91	9.09

SLE and SLF

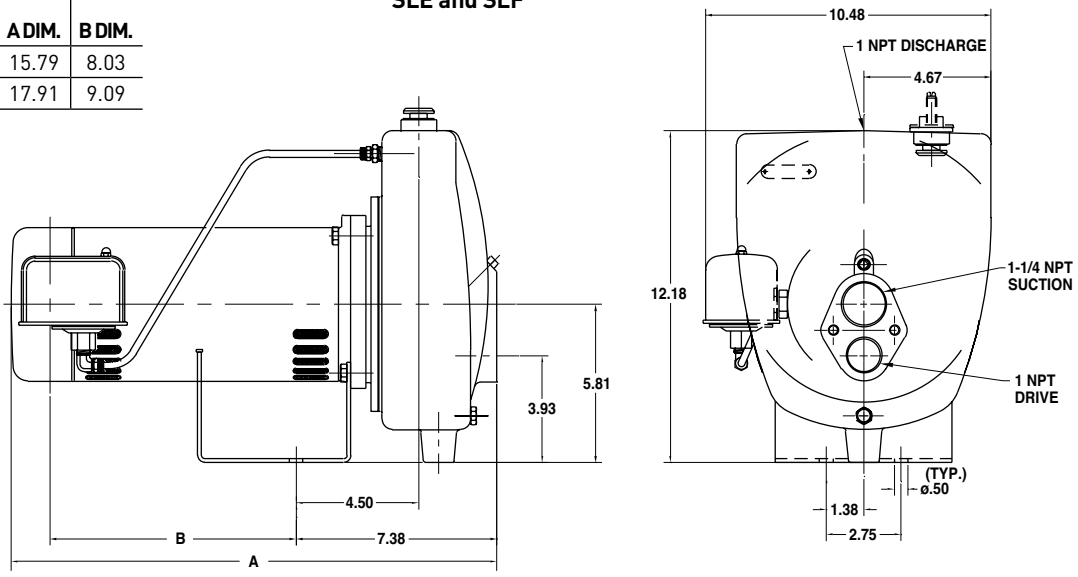

Dimensions (in inches) are for estimating purposes only.

# ProJet™ SL Series

Cast iron, self-priming convertible jet pumps

**PUMP PERFORMANCE** (Capacity in gallons per minute)  
**SHALLOW WELL – 5', 10', 15', 20' AND 25' PUMPING DEPTHS**

CAT. NO.	HP	DISCH. PRESS.	PUMPING DEPTH TO WATER IN FEET																													
			5 FT. LIFT					10 FT. LIFT					15 FT. LIFT					20 FT. LIFT					25 FT. LIFT									
SLC	1/2	<b>JET PACKAGE</b>	10SD	29SD	CK3			10SD	29SD	CK3			10SD	29SD	CK3			10SD	29SD	CK3			10SD	29SD	CK3							
		Venturi N32P-__	-67B	-66B	-78B			-67B	-66B	-78B			-67B	-66B	-78B			-67B	-66B	-78B			-67B	-66B	-78B							
		Nozzle J34P-__	-44	-41	-41			-44	-41	-41			-44	-41	-41			-44	-41	-41			-44	-41	-41							
		20 PSI	12.0	9.1	5.9			9.7	8.4	5.4			12.0	7.3	4.7			9.7	6.2	4.0			6.7	4.7	3.1							
		30 PSI	10.8	9.0	5.8			9.5	8.3	5.3			10.8	7.2	4.6			9.5	6.1	3.9			6.7	4.7	3.0							
		40 PSI	5.2	7.9	5.6			4.2	7.2	5.2			5.2	6.3	4.5			4.2	5.4	3.8			2.5	4.1	2.9							
		50 PSI		4.1	4.5				3.8	4.1				3.3	3.6				2.8	3.1				2.1	2.3							
		60 PSI			2.4					2.2					1.9					1.6												
		Shut-off-PSI	53	61	70			51	58	66			49	56	64			47	54	61			45	52	58							
SLD	3/4	<b>JET PACKAGE</b>	11SD	10SD	29SD	CK5			11SD	10SD	29SD	CK5			11SD	10SD	29SD	CK5			11SD	10SD	29SD	CK5			11SD	10SD	29SD	CK5		
		Venturi N32P-__	-68B	-67B	-66B	-66B			-68B	-67B	-66B	-66B			-68B	-67B	-66B	-66B			-68B	-67B	-66B	-66B			-68B	-67B	-66B	-66B		
		Nozzle J34P-__	-44	-44	-41	-45			-44	-44	-41	-45			-44	-44	-41	-45			-44	-44	-41	-45			-44	-44	-41	-45		
		20 PSI	20.6	14.4	10.1	6.6			19.0	13.2	9.3	6.1			16.5	11.5	8.1	5.3			13.3	9.5	6.9	4.5			9.8	6.9	5.3	3.4		
		30 PSI	19.6	14.3	9.9	6.5			18.1	13.1	9.1	6.0			15.7	11.4	7.9	5.2			13.3	9.5	6.7	4.4			9.8	6.9	5.1	3.4		
		40 PSI	10.3	12.1	9.8	6.4			9.4	11.2	9.0	5.9			8.2	9.7	7.8	5.1			6.4	8.3	6.6	4.3			3.1	6.3	5.1	3.3		
		50 PSI		4.6	7.3	6.3				4.3	6.7	5.8				3.7	5.8	5.0				2.6	4.9	4.3				1.0	3.8	3.3		
		60 PSI			3.5	5.8					3.2	5.3					2.8	4.6					2.4	3.9						3.0		
		Shut-off-PSI	55	59	70	72			53	57	66	67			50	55	64	65			48	53	61	63			46	51	59	61		
SLE	1	<b>JET PACKAGE</b>	12SD	11SD	CK1	CK5	CK1	12SD	11SD	CK1	CK5	CK1	12SD	11SD	CK1	CK5	CK1	12SD	11SD	CK1	CK5	CK1	12SD	11SD	CK1	CK5	CK1	12SD	11SD	CK1	CK5	CK1
		Venturi N32P-__	-65	-68B	-72E	-67B	-72	-65	-68B	-72E	-67B	-72	-65	-68B	-72E	-67B	-72	-65	-68B	-72E	-67B	-72	-65	-68B	-72E	-67B	-72	-65	-68B	-72E	-67B	-72
		Nozzle J34P-__	-44	-44	-43	-45	-43	-44	-44	-43	-45	-43	-44	-44	-43	45	-43	-44	-44	-43	-45	-43	-44	-44	-43	-45	-43	-44	-44	-43	-45	-43
		20 PSI	24.2	20.3	14.5	12.6	8.6	23.2	19.4	13.9	12.1	8.3	20.2	16.9	12.1	10.5	7.2	17.7	13.6	10.3	8.2	6.1	12.5	10.4	7.9	6.2	4.7					
		30 PSI	24.0	20.3	14.4	12.4	8.5	23.0	19.4	13.8	11.8	8.2	20.0	16.9	12.0	10.3	7.1	17.7	13.6	10.2	8.0	6.0	12.5	10.4	7.8	6.0	4.6					
		40 PSI	16.7	16.4	13.7	12.2	8.3	16.0	15.8	13.1	11.7	7.9	13.9	13.7	11.4	10.2	6.9	11.8	11.5	9.7	7.8	5.9	10.3	8.3	7.4	5.8	4.5					
		50 PSI			12.6	12.0	8.2			12.1	11.5	7.8			10.5	10.0	6.8			8.9	7.7	5.8			6.8	5.7	4.4					
		60 PSI			6.0	8.2	6.1			5.8	7.8	5.9			5.0	6.8	5.1			4.3	5.8	4.3			3.3	4.8	3.3					
		70 PSI				4.2	2.9				4.0	2.8				3.5	2.4				2.8	2.0				2.0	1.6					
Shut-off-PSI	61	62	71	80	82	59	60	69	78	79	57	58	67	76	77	54	55	65	74	75	52	53	63	72	73							
SLF	1-1/2	<b>JET PACKAGE</b>	12SD	CK2	60SD			12SD	CK2	60SD			12SD	CK2	60SD			12SD	CK2	60SD			12SD	CK2	60SD							
		Venturi N32P-__	-65	-64	-64			-65	-64	-64			-65	-64	-64			-65	-64	-64			-65	-64	-64							
		Nozzle J34P-__	-44	-44	-45			-44	-44	-45			-44	-44	-45			-44	-44	-45			-44	-44	-45							
		20 PSI	26.8	21.6	18.4			24.6	19.9	16.9			21.4	17.3	14.7			18.2	14.7	12.5			13.9	11.2	9.6							
		30 PSI	26.5	21.5	18.1			24.4	19.8	16.7			21.2	17.2	14.5			18.0	14.6	12.3			13.8	11.2	9.4							
		40 PSI	22.9	21.3	17.5			21.0	19.6	16.1			18.3	17.0	14.0			15.6	14.5	11.9			11.9	11.1	9.1							
		50 PSI	15.1	16.8	17.3			13.9	15.4	15.9			12.1	13.4	13.8			10.3	11.4	11.7			7.9	8.7	9.0							
		60 PSI		4.0	15.6				3.7	14.4				3.2	12.5				2.7	10.6				2.1	8.1							
		70 PSI			4.1					3.8					3.3					2.8												
Shut-off-PSI	61	71	77			59	69	75			57	67	73			55	65	71			53	63	68									

Pumps are supplied with 30–50 pressure switch setting. Cut-in pressure settings are adjustable.

# ProJet™ SL Series

Cast iron, self-priming convertible jet pumps

**PUMP PERFORMANCE** (Capacity in gallons per minute)  
**DEEP WELL (40 PSI) 4" DOUBLE PIPE**

CAT. NO.	HP	JET NO.	USES VENTURI	USES NOZZLE	PUMPING DEPTH IN FEET											MAX. PUMP SHUT-OFF PRESSURE PSI	
					20'	30'	40'	50'	60'	70'	80'	90'	100'	110'	120'	JET AT 20 FT. DEPTH	JET AT MAX. DEPTH
SLC	1/2	4SD	J32P-24	J34P-41	5.9	4.5	3.4	2.3								68	54
		15SD	J32P-18	J34P-42	4.6	3.9	3.3	2.8	2.3	1.7						84	59
SLD	3/4	CK3	J32P-26	J34P-41	9.4	8.0	6.6									77	68
		54SD	J32P-22	J34P-44	8.0	6.9	5.7	4.8	3.8	3.2						94	70
		CK5	N32P-66B	J34P-45	7.3	6.2	5.0	4.0								83	69
		55SD	J32P-18	J34P-43	5.0	4.3	3.7	3.2	2.6	2.2	1.8	1.5				96	63
SLE	1	CK1	N32P-72	J34P-43	13.2	10.8	8.4	6.3	4.2							74	56
		CK2	J32P-24	J34P-44	13.0	11.5	9.9	8.7	7.5	6.6	5.4					105	80
		54SD	J32P-22	J34P-44	8.5	7.7	6.7	6.3	5.8	5.4	4.8	4.0	3.7	3.4	2.7	122	73
SLF	1-1/2	54SD	J32P-22	J34P-44	9.5	8.5	7.4	6.9	6.5	6.0	5.5	4.8	4.2	3.6	2.9	127	76

Tank body on SLF pump tapped 1-1/4" x 1". On SLF pump, drop pipe should be increased to 1-1/2" x 1-1/4" to ensure adequate capacity from pump.

**PUMP PERFORMANCE** (Capacity in gallons per minute)  
**DEEP WELL (40 PSI) 2" SINGLE PIPE**

CAT. NO.	HP	JET NO.	USES VENTURI	USES NOZZLE	PUMPING DEPTH IN FEET											MAX. PUMP SHUT-OFF PRESSURE PSI	
					20'	30'	40'	50'	60'	70'	80'	90'	100'	110'	120'	JET AT 20 FT. DEPTH	JET AT MAX. DEPTH
SLC	1/2	8AP	J32P-18	J34P-42	4.7	4.1	3.4	2.5	1.9	1.5						84	58
SLD	3/4	54AP	J32P-22	J34P-44	7.4	6.3	5.2	3.9	2.5	2.0						82	54
SLE	1	10AP	J32P-24	J34P-44	10.5	10.0	8.1	6.2								96	79
		54AP	J32P-22	J34P-44	6.0	5.3	4.8	4.2	4.1	3.7	3.5	2.8	2.1	1.6		95	53
SLF	1-1/2	9AP	J32P-29	J34P-44	11.7	11.1	9.8	6.8								69	57
		8AP	J32P-18	J34P-42	6.7	5.8	5.3	4.7	4.5	4.1	3.8	3.1	2.6	2.0	1.6	129	72

**DEEP WELL (40 PSI) 3" SINGLE PIPE**

SLC	1/2	19CP	J32P-24	J34P-41	5.9	4.5	3.4	2.3								68	54
		16CP	J32P-18	J34P-42	4.6	3.9	3.3	2.8	2.3	1.7						84	59
		9CP	J32P-26	J34P-41	9.4	8.0	6.6									77	68
SLD	3/4	54CP	J32P-22	J34P-44	8.0	6.9	5.7	4.8	3.8	3.2						94	70
SLE	1	18CP	J32P-24	J34P-44	13.0	11.5	9.9	8.7	7.5	6.6	5.4					106	80
		54CP	J32P-22	J34P-44	8.5	7.7	6.7	6.3	5.8	5.4	4.8	4.0	3.7	3.4	2.7	122	73
		57CP	J32P-33	P122-10B	18.0	15.4	12.8	10.8								81	68
SLF	1-1/2	54CP	J32P-22	J34P-44	9.5	8.5	7.4	6.9	6.5	6.0	5.4	4.8	4.2	3.6	2.9	127	76

Tank body on SLF pump tapped 1-1/4" x 1". Drop pipe should be increased to 1-1/2" x 1-1/4" to ensure adequate capacity from pump. Tested and rated in accordance with Water Systems Council Standards.

NOTE: Pumps installed with a Pro-Source® tank require a 100 PSI relief valve. Pumps installed with a conventional tank require a 75 PSI relief valve. Relief valve must be capable of relieving entire flow of pump at relief pressure.

# FL Series

Cast iron, self-priming convertible jet pumps

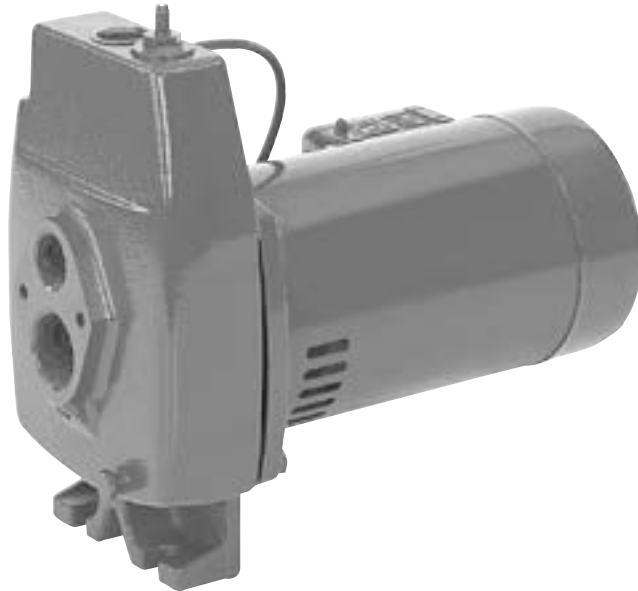

**FL Series Pumps feature a proven self-priming “convertible” design. The same convertible jet can be attached to pump for use on shallow well installation, or be utilized in 4” or larger wells for use as a double pipe deep well jet.**

**FL Series Pumps provide high capacities up to 11 GPM...depths to 90 feet. They are rated for 30-50 PSI operation.**

## APPLICATIONS

**Water systems and sprinkling...**for homes, farms and cottages

## SPECIFICATIONS

**Body and Base:** Close-grained cast iron

**Impeller:** Lexan®

**Diffuser:** Reinforced polypropylene

**Shaft:** One-piece threaded 416 stainless steel

**Pressure Switch Pre-Set:** 30-50 PSI

**Suction Ports:** Drive-over-Suction

## FEATURES

**Quality Construction:** Close-grained cast iron pump body and base are rugged one-piece unit, specially treated to resist corrosion. Drain port provided for easy winterizing.

**Pressure Regulator:** Simple, built-in regulator is performance proven. Adjustable for best performance on all deep well installations.

**Lexan Impeller:** Precision-molded for perfect balance...ultra-smooth for highest performance and efficiency.

**Precision-Molded Diffuser:** Pump primes faster, handles more air, with multi-port, precision-molded, reinforced polypropylene diffuser.

**Mechanical Shaft Seal:** Precision-lapped and highly polished carbon-ceramic, stainless steel construction. Internal design guarantees continuous water lubrication for maximum protection.

**Motor Windings:** Superior insulation materials protect against excessive moisture and contaminants...assures prolonged motor life.

**Balanced Rotor:** Diecast under high pressures for uniform performance and greater efficiency...dynamically balanced.

**Heavy-Duty Ball Bearings:** Shielded, permanently lubricated bearings, extensively tested to ensure extended life and smooth, quiet operation.

**Pump and Motor Shaft:** Stainless steel for maximum corrosion resistance; one-piece threaded shaft for positive impeller drive and alignment.

**Dustproof Cover:** Dustproof canopy protects all electrical components from dirt, dust and insects; ventilating air cannot contaminate vital switching components... eliminates the most common cause of motor failure.

## ORDERING INFORMATION

CATALOG NUMBER	HP	DESCRIPTION	PIPE TAPPING SIZES			MOTOR VOLTAGE	APPROX. WT. LBS.
			SUCT.	DRIVE	DISCH.		
FLC	1/2	Deep Well Jet	1-1/4"	1"	1"	115/230	44
FLD	3/4	Deep Well Jet	1-1/4"	1"	1"	115/230	45

A Jet Package should be ordered with every FL Series Pump.

NOTE: Pumps installed with a Pro-Source® tank require a 100 PSI relief valve. Pumps installed with a conventional tank require a 75 PSI relief valve. Relief valve must be capable of relieving flow of pump at relief pressure.

Pentair trademarks and logos are owned by Pentair plc or its affiliates. All other third party registered and unregistered trademarks and logos are the property of their respective owners.

# FL Series

Cast iron, self-priming convertible jet pumps

## OUTLINE DIMENSIONS

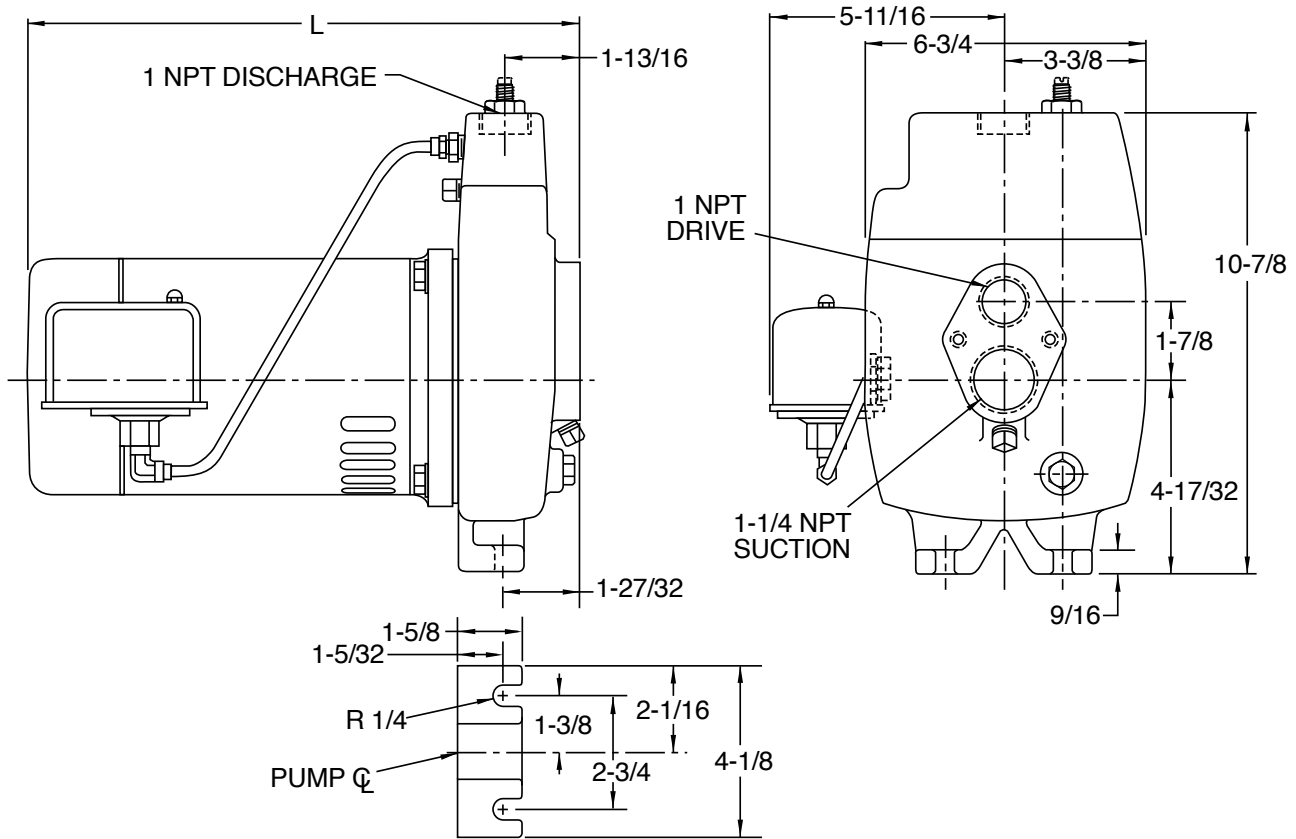

MOUNTING BRACKET DETAIL

CATALOG NUMBER	L
FLC	11-13/16
FLD	12-9/16

Dimensions (in inches) are for estimating purposes only.

# FL Series

Cast iron, self-priming convertible jet pumps

**PUMP PERFORMANCE** (Capacity in gallons per minute)  
**SHALLOW WELL – 5', 10', 15', 20' AND 25' PUMPING DEPTHS**

CAT. NO.	HP	DISCHARGE PRESSURE	PUMPING DEPTH TO WATER IN FEET														
			5 FT. LIFT			10 FT. LIFT			15 FT. LIFT			20 FT. LIFT			25 FT. LIFT		
		JET PACKAGE	10SD	29SD		10SD	29SD		10SD	29SD		10SD	29SD		10SD	29SD	
FLC	1/2	Venturi N32P-__	-67B	-66B		-67B	-66B		-67B	-66B		-67B	-66B		-67B	-66B	
		Nozzle J34P-__	-44	-41		-44	-41		-44	-41		-44	-41		-44	-41	
		20 PSI	12.0	9.1		9.7	8.4		12.0	7.3		9.7	6.2		6.7	4.7	
		30 PSI	10.8	9.0		9.5	8.3		10.8	7.2		9.5	6.1		6.7	4.7	
		40 PSI	5.2	7.9		4.2	7.2		5.2	6.3		4.2	5.4		2.5	4.1	
		50 PSI		4.1			3.8			3.3			2.8			2.1	
		60 PSI															
		Shut-off-PSI	53	61		51	58		49	56		47	54		45	52	
FLD	3/4	JET PACKAGE	11SD	10SD	29SD	11SD	10SD	29SD	11SD	10SD	29SD	11SD	10SD	29SD	11SD	10SD	29SD
		Venturi N32P-__	-68B	-67B	-66B	-68B	-67B	-66B	-68B	-67B	-66B	-68B	-67B	-66B	-68B	-67B	-66B
		Nozzle J43P-__	-44	-44	-41	-44	-44	-41	-44	-44	-41	-44	-44	-41	-44	-44	-41
		20 PSI	20.6	14.4	10.1	19.0	13.2	9.3	16.5	11.5	8.1	13.3	9.5	6.9	9.8	6.9	5.3
		30 PSI	19.6	14.3	9.9	18.1	13.1	9.1	15.7	11.4	7.9	13.3	9.5	6.7	9.8	6.9	5.1
		40 PSI	10.3	12.1	9.8	9.4	11.2	9.0	8.2	9.7	7.8	6.4	8.3	6.6	3.1	6.3	5.1
		50 PSI		4.6	7.3		4.3	6.7		3.7	5.8		2.6	4.9		1.0	3.8
		60 PSI			3.5			3.2			2.8			2.4			
Shut-off-PSI	55	59	70	53	57	66	50	55	64	48	53	61	46	51	59		

NOTE: Pumps are supplied with 30-50 pressure switch setting. Cut-in pressure settings are adjustable.

**PUMP PERFORMANCE** (Capacity in gallons per minute)  
**DEEP WELL (40 PSI) 4" DOUBLE PIPE**

CAT. NO.	HP	JET NO.	USES VENTURI	USES NOZZLE	PUMPING DEPTH IN FEET									MAX. PUMP SHUT-OFF PRESSURE PSI	
					20'	30'	40'	50'	60'	70'	80'	90'	JET AT 20 FT. DEPTH	JET AT MAX. DEPTH	
FLC	1/2	4SD	J32P-24	J34P-41	5.9	4.5	3.4	2.3						68	54
		15SD	J32P-18	J34P-42	4.6	3.9	3.3	2.8	2.3	1.7				84	59
FLD	3/4	54SD	J32P-22	J34P-44	8.0	6.9	5.7	4.8	3.8	3.2				94	70
		55SD	J32P-18	J34P-43	5.0	4.3	3.7	3.2	2.6	2.2	1.8	1.5		96	63

**DEEP WELL (40 PSI) 2" SINGLE PIPE**

FLC	1/2	8AP	J32P-18	J34P-42	4.7	4.1	3.4	2.5	1.9	1.5			84	58
FLD	3/4	54AP	J32P-22	J34P-44	7.4	6.3	5.2	3.9	2.5	2.0			82	54

**DEEP WELL (40 PSI) 3" SINGLE PIPE**

FLC	1/2	19CP	J32P-24	J34P-41	5.9	4.5	3.4	2.3					68	54
		16CP	J32P-18	J34P-42	4.6	3.9	3.3	2.8	2.3	1.7			84	59
FLD	3/4	9CP	J32P-26	J34P-41	9.4	8.0	6.6						77	68
		54CP	J32P-22	J34P-44	8.0	6.9	5.7	4.8	3.8	3.2			94	70

Tested and rated in accordance with Water Systems Council Standards.

NOTE: Pumps installed with a Pro-Source® tank require a 100 PSI relief valve. Pumps installed with a conventional tank require a 75 PSI relief valve. Relief valve must be capable of relieving entire flow of pump at relief pressure.

# PL Series

Corrosion-resistant, convertible deep well jet pumps



Durability and corrosion resistance are built into every PL Series Pump, due to the rugged fiberglass reinforced thermoplastic pump construction. The engineered composite components are lightweight yet extremely resistant to sand and abrasive wear. The non-corrosive design and exceptional strength assure years of trouble-free operation.

## APPLICATIONS

Water systems and sprinkling... for homes, farms and cottages.

## SPECIFICATIONS

- Pump Body and Seal Plate:** Dura-Glas®
- Impeller:** Noryl®
- Nozzle:** Noryl
- Venturi:** Noryl
- O-Ring:** Buna-N
- Clamp:** Stainless steel
- Shaft:** Stainless steel
- Diffuser:** Reinforced polypropylene with brass wear ring
- Shallow Well Jet:** Sold separately
- Pressure Switch Pre-Set:** 30–50 PSI
- Suction Ports:** Suction-over-Drive

## FEATURES

**Superior Rustproof Construction:** Pump body is Dura-Glas fiberglass reinforced thermoplastic—lightweight, rustproof and exceptionally strong. All components in contact with water are resistant to the corrosive and abrasive forces found in the most aggressive water conditions.

**Precision Diffuser:** Multi-port, reinforced polypropylene design primes faster and handles more air.

**Precision-Molded Impeller:** Precision-molded Noryl gives perfect balance and ultra-smoothness for highest performance and efficiency.

**Pressure Regulator and Gauge:** Performance-proven, simple, built-in pressure regulator is adjustable for best performance on all deep well installations. Pressure gauge included.

**Shaft Seal:** Stainless steel heat sink provides maximum cooling of the mechanical shaft seal.

**Heavy-Duty Motor:** Dustproof canopy completely encloses electrical components and provides dust, dirt and insect protection. Ventilating air cannot contaminate vital switching components. Permanently lubricated, heavy-duty ball bearings ensure smooth, quiet operation and extended motor life.

**Easy Serviceability:** PL pumps are disassembled by removing the stainless steel clamp. Piping does not have to be disturbed. Seal replacement takes only a few minutes. “Control room” motor design makes all components easily accessible.

## ORDERING INFORMATION

CATALOG NUMBER	HP	DESCRIPTION	PIPE TAPPING SIZES			MOTOR VOLTAGE	APPROX. WT. LBS.
			SUCT.	DRIVE	DISCH.		
PLC	1/2	Deep Well Jet	1-1/4"	1"	1"	115/230	27
PLD	3/4	Deep Well Jet	1-1/4"	1"	1"	115/230	28
PLE	1	Deep Well Jet	1-1/4"	1"	1"	115/230	30
PLF	1-1/2	Deep Well Jet	1-1/4"	1"	1"	115/230	36

A Jet Package should be ordered with every PL Series pump. Pentair trademarks and logos are owned by Pentair plc or its affiliates. All other third party registered and unregistered trademarks and logos are the property of their respective owners.

# PL Series

Corrosion-resistant, convertible deep well jet pumps

## OUTLINE DIMENSIONS

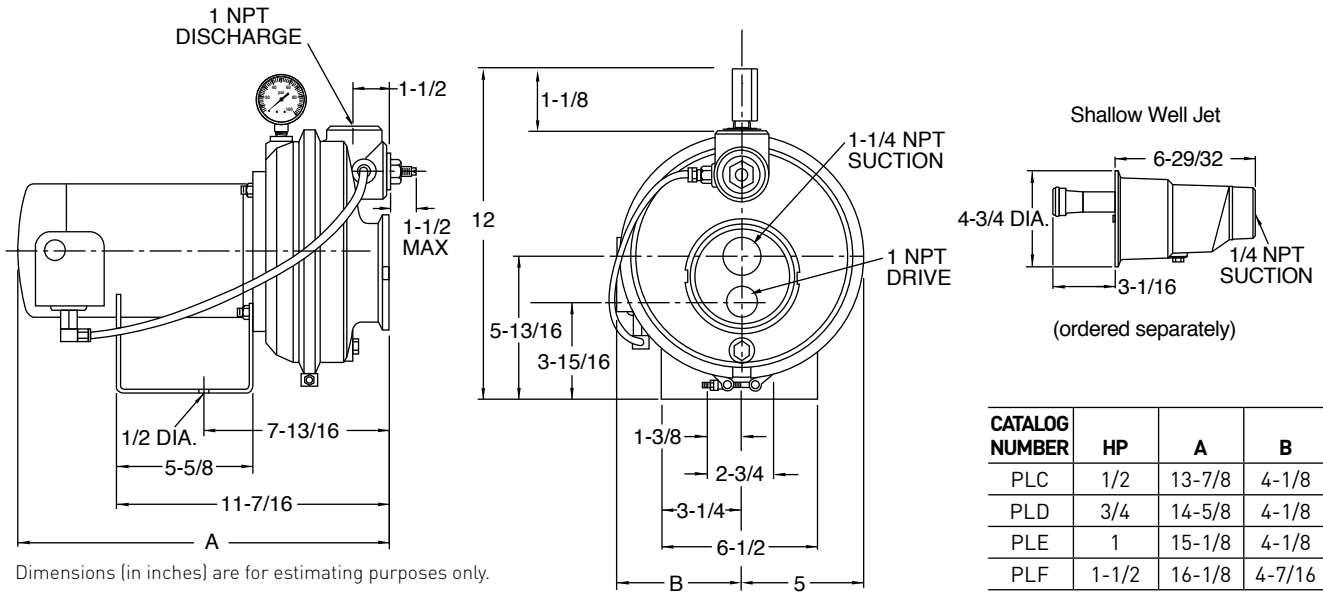

CATALOG NUMBER	HP	A	B
PLC	1/2	13-7/8	4-1/8
PLD	3/4	14-5/8	4-1/8
PLE	1	15-1/8	4-1/8
PLF	1-1/2	16-1/8	4-7/16

## PUMP PERFORMANCE (Capacity in gallons per minute) SHALLOW WELL

CATALOG NUMBER	HP	S.W. JET NUMBER	PRESS. SWITCH SETTING	DYNAMIC SUCTION LIFT FT.	DISCHARGE PRESSURE PSI					SHUT-OFF PRESSURE PSI
					20'	30'	40'	50'	60'	
PLC	1/2	PKG 1 - 21N	30-50	5'	9.5	9.2	9.0	5.8	3.0	72
				10'	8.2	8.0	7.8	5.2	2.3	70
				15'	7.2	6.8	6.8	4.5	1.8	68
				20'	5.7	5.7	5.7	3.8		66
				25'	4.3	4.3	4.3	3.2		62
PLD	3/4	PKG 1 - 22N	30-50	5'	16.2	15.8	15.3	8.7	1.3	62
				10'	14.2	14.0	13.8	7.2		60
				15'	12.2	12.0	11.8	5.3		58
				20'	9.7	9.7	9.2	3.7		55
				25'	7.2	6.8	6.8			52
PLE	1	PKG 1 - 23N	30-50	5'	21.3	21.0	20.7	13.2	4.2	62
				10'	18.8	18.7	18.3	11.1	1.7	60
				15'	16.0	15.8	15.7	8.9		58
				20'	12.8	12.7	12.3	5.7		55
				25'	8.5	8.5	8.5			52
PLF	1-1/2	PKG 1 - 24N	30-50	5'	26.3	26.2	26.2	21.3	7.7	64
				10'	23.7	23.3	23.2	19.2	3.5	62
				15'	20.3	20.2	20.0	16.3		60
				20'	16.2	16.0	15.8	11.2		57
				25'	11.5	11.3	11.3			54

Tested and rated in accordance with Water Systems Council Standards.

NOTE: Pumps installed with a Pro-Source® tank require a 100 PSI relief valve. Pumps installed with a conventional tank require a 75 PSI relief valve. Relief valve must be capable of relieving entire flow of pump at relief pressure.

# PL Series

Corrosion-resistant, convertible deep well jet pumps

PUMP PERFORMANCE (Capacity in gallons per minute)													
DEEP WELL (40 PSI) 4" DOUBLE PIPE													
CAT. NO.	HP	JET NO.	USES VENTURI	USES NOZZLE	PUMPING DEPTH IN FEET								
					30'	40'	50'	60'	70'	80'	90'	100'	
PLC	1/2	4SD	J32P-24	J34P-41	4.5	3.5	2.3	1.3					
		10SD	N32P-67B	J34P-44	9.5	7.0	4.5	2.0					
PLD	3/4	4SD	J32P-24	J34P-41	6.5	5.1	4.0	3.0	1.8	0.8			
PLE	1	4SD	J32P-24	J34P-41	8.4	7.3	6.2	5.0	4.1	2.9	2.0	1.1	
PLF	1-1/2	11SD	N32P-68B	J34P-44	11.5	9.4	8.0	6.5	5.3	3.8	2.5	1.1	

PUMP PERFORMANCE (Capacity in gallons per minute)														
DEEP WELL (40 PSI) 2" SINGLE PIPE														
CAT. NO.	HP	JET NO.	USES VENTURI	USES NOZZLE	PUMPING DEPTH IN FEET									
					20'	30'	40'	50'	60'	70'	80'	90'	100'	110'
PLC	1/2	13AP	J32P-26	J34P-44	5.8	3.8	1.0							
		10AP	J32P-24	J34P-44	4.3	3.0	1.6							
		8AP	J32P-18	J34P-42	3.8	3.3	2.6	2.0	1.5					
PLD	3/4	14AP	J32P-32	J34P-45	9.2	6.7	4.3							
		10AP	J32P-24	J34P-44	6.2	4.8	3.7	2.3	1.2					
		8AP	J32P-18	J34P-42	4.1	3.7	3.1	2.6	2.1	1.6	1.2	0.8		
PLE	1	15AP	J32P-33	J34P-41	12.3	9.2	5.7							
		9AP	J32P-29	J34P-44	10.6	7.4	4.7	2.2						
		8AP	J32P-18	J34P-42	5.0	4.7	4.2	3.8	3.3	2.7	2.3	1.8	1.3	
PLF	1-1/2	16AP	J32P-38	J34P-45	15.3	11.8	8.5	5.2						
		9AP	J32P-29	J34P-44	-	12.3	9.3	6.4	4.0					
		8AP	J32P-18	J34P-42	-	5.7	5.0	4.6	4.2	3.7	3.3	2.8	2.4	1.8

DEEP WELL (40 PSI) 3" SINGLE PIPE														
PLC	1/2	25CP	J32P-26	J34P-44	5.8	4.0	2.1							
		19CP	J32P-24	J34P-41	-	4.5	3.5	2.3	1.3					
PLD	3/4	11CP	J32P-32	J34P-45	9.5	7.0	4.5	2.0						
		19CP	J32P-24	J34P-41	-	6.5	5.1	4.0	3.0	1.8	0.8			
PLE	1	26CP	J32P-33	J34P-41	13.0	9.8	6.0							
		17CP	J32P-29	J34P-44	-	11.5	8.0	5.2	2.6					
		19CP	J32P-24	J34P-41	-	8.4	7.3	6.2	5.0	4.1	2.9	2.0	1.1	
PLF	1-1/2	10CP	J32P-38	J34P-45	16.6	13.3	9.5	6.0						
		15CP	J32P-22	J34P-43	-	8.6	7.9	6.9	6.2	5.4	4.4	3.2	2.2	1.5

Tested and rated in accordance with Water Systems Council Standards.

NOTE: Pumps installed with a Pro-Source® tank require a 100 PSI relief valve. Pumps installed with a conventional tank require a 75 PSI relief valve. Relief valve must be capable of relieving entire flow of pump at relief pressure.

# HMS Series

Cast iron, horizontal multi-stage



HMS Series Multi-Stage Jet Pumps are the highest performing pumps available in its category. The HMS Series Convertible Jets utilize the built-in regulator, offering easier priming and better range of performance from a complete line of Shallow Well, 4" Double Pipe, 2" and 3" Single Pipe Jet Packages. Pump may also be operated as a self-priming centrifugal (to 25 ft.) to provide a wide range of high pressure applications.

## APPLICATIONS

**Water systems and sprinkling...** for homes, farms and cottages.

## SPECIFICATIONS

**Body:** One-piece rugged cast iron

**Pump and Motor Shaft:** 416 stainless steel

**Impeller:** Polycarbonate

**Diffuser:** Corrosion-resistant cast iron

**Pressure Switch Pre-Set:** 30-50 PSI

**Suction Ports:** Drive-over-Suction

## ORDERING INFORMATION

CATALOG NUMBER	HP	DESCRIPTION	PIPE TAPPING SIZES			STAGES	MOTOR VOLTAGE	APPROX. WT. LBS.
			SUCT.	DRIVE	DISCH.			
HMSD	3/4	Deep Well Jet	1-1/4"	1"	1"	2	115/230	50
HMSE	1	Deep Well Jet	1-1/4"	1"	1"	2	115/230	80
HMSF	1-1/2	Deep Well Jet	1-1/4"	1"	1"	2	115/230	85

## AUTOMATIC PRESSURE REGULATOR – DEEP WELL

CATALOG NUMBER	DESCRIPTION	APPLICATION	APPROX. WT. LBS.
PKG 107	Regulator, tubing, pipe plug and compression fitting	Required for ALL deep well installations	4

## FEATURES

**Automatic Pressure Regulator:** Faster-acting and quieter, design eliminates "hunting" for correct drive pressure. New improved stem and guide are precisely molded to assure efficient, trouble-free performance on all deep wells. See ordering information (deep well only).

**Quality Construction:** Close-grained cast iron pump body is rugged, one-piece unit, specially treated to resist corrosion. Drain port provided for easy winterizing.

**Precision-Machined Diffusers:** Assure faster priming.

**Mechanical Shaft Seal:** Precision-lapped and highly polished carbon-ceramic, stainless steel construction. Internal design guarantees continuous water lubrication for maximum protection.

**Polycarbonate Impellers:** Precision-molded for perfect balance, and ultra-smooth for highest performance and efficiency.

**Motor Windings:** Superior insulation materials protect against excessive moisture and contaminants to ensure prolonged motor life.

**Dustproof Cover:** All electrical components are protected from dirt, dust and insects by a dustproof canopy. Ventilating air cannot contaminate vital switching components. This eliminates the most common cause of motor failure.

**Balanced Rotor:** Diecast under high pressures for uniform performance and greater efficiency...dynamically balanced.

**Heavy-Duty Ball Bearings:** Shielded, permanently lubricated bearings are extensively tested to ensure extended life and smooth, quiet operation.

**Pump and Motor Shaft:** Stainless steel for maximum corrosion resistance; one-piece threaded shaft for positive impeller drive and alignment.

Order pump and pressure regulator, if required, from ordering information tables above.

A Jet Package and the Automatic Pressure Regulator, described above, are required on all deep well installations.

# HMS Series

Cast iron, horizontal multi-stage

**PUMP PERFORMANCE: 10 GPM**

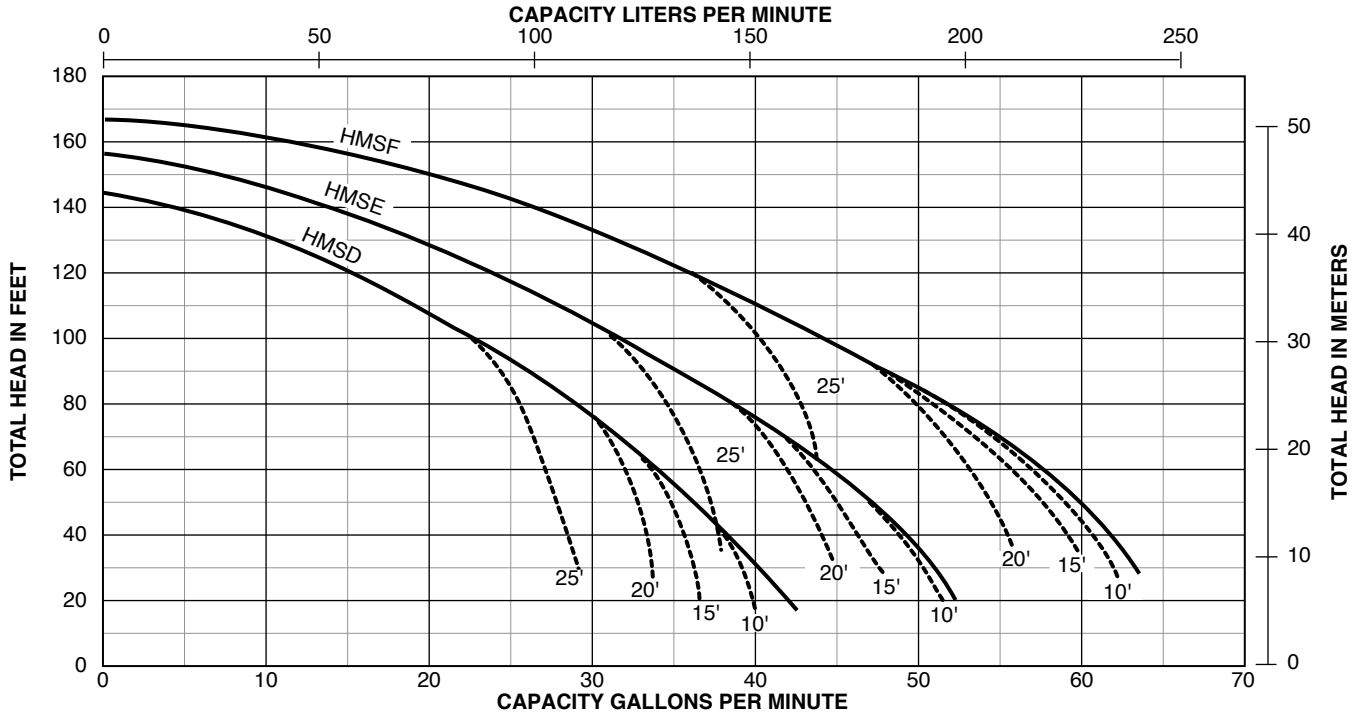

NOTE: Dotted lines indicate performance reduction at high suction lift.

**PUMP PERFORMANCE** (Capacity in gallons per minute)  
**CENTRIFUGAL APPLICATION**

CATALOG NUMBER	HP	TOTAL SUCTION LIFT FT.	DISCHARGE PRESSURE PSI					SHUT-OFF PRESSURE PSI
			20'	30'	40'	50'	60'	
HMSD	3/4	5	37	30	24	15		60
		10	35	29	21	13		60
		15	33	27	19	9		60
		20	32	26	17	6		60
		25	31	24	15			60
HMSE	1	5	47	40	33	24	10	65
		10	46	38	31	21	7	65
		15	44	36	28	18		65
		20	42	35	26	15		65
		25	41	33	24	12		65
HMSF	1-1/2	5	60	53	46	36	23	68
		10	58	52	43	33	21	68
		15	56	49	41	30	16	68
		20	55	47	39	27	12	68
		25	54	41	36	25		68

Tested and rated in accordance with Water Systems Council Standards.

NOTE: Pumps installed with a Pro-Source® tank require a 100 PSI relief valve. Pumps installed with a conventional tank require a 75 PSI relief valve. Relief valve must be capable of relieving entire flow of pump at relief pressure. PKG 107 Regulator, tubing, pipe plug and compression fitting is required for all DEEP WELL installations.

# HMS Series

Cast iron, horizontal multi-stage

## PUMP PERFORMANCE: SHALLOW WELL

CATALOG NUMBER	HP	JET* NUMBER	USES VENTURI	USES NOZZLE	DISCH. PRESS. PSI	TOTAL SUCTION LIFT FT.				
						5'	10'	15'	20'	25'
HMSD	3/4	PKG 1 - 29SD	N32P-66B	J34P-41	20	9.6	8.2	7.0	5.8	3.9
					30	9.1	7.9	6.5	5.6	3.9
					40	8.8	7.7	6.3	5.6	3.9
					50	8.5	7.6	6.2	5.6	3.9
					60	7.7	7.3	6.2	5.6	3.9
					70	5.5	5.1	4.7	4.2	3.6
					80	3.5	3.1	2.8	2.3	1.9
Shut-off	102	96	96	96	90					
HMSE	1	PKG 1 - 10SD	N32P-67B	J34P-44	20	13.0	11.2	9.8	7.8	5.8
					30	12.5	11.0	9.5	7.6	5.7
					40	12.2	10.9	9.4	7.6	5.7
					50	12.1	10.8	9.2	7.6	5.7
					60	12.0	10.8	9.2	7.6	5.7
					70	10.2	9.6	8.6	7.4	5.7
					80	7.4	6.8	6.2	5.5	4.8
Shut-off	108	108	108	102	102					
HMSE	1	PKG 1 - 10SD	N32P-67B	J34P-44	20	15.9	13.3	12.2	9.6	7.0
					30	15.6	13.2	12.2	9.5	7.0
					40	15.3	13.1	12.1	9.4	6.9
					50	14.9	13.0	11.9	9.3	6.8
					60	14.4	12.9	11.7	9.2	6.7
					70	13.7	12.7	11.5	9.0	6.6
					80	12.6	12.1	10.8	8.7	6.4
					90	9.5	8.5	7.8	7.2	5.7
					100	5.9	5.0	4.4	3.8	3.2
					Shut-off	120	120	114	114	108

\* Order Jet Package separately.

Tested and rated in accordance with Water Systems Council Standards.

NOTE: Pumps installed with a Pro-Source® tank require a 100 PSI relief valve.

Pumps installed with a conventional tank require a 75 PSI relief valve.

Relief valve must be capable of relieving entire flow of pump at relief pressure.

## OUTLINE DIMENSIONS

CAT. NO.	A	B	C
HMSD	16-7/8	9-1/2	5-1/8
HMSE	17-3/4	9-1/2	5-1/8
HMSF	18-1/4	10	5-5/8

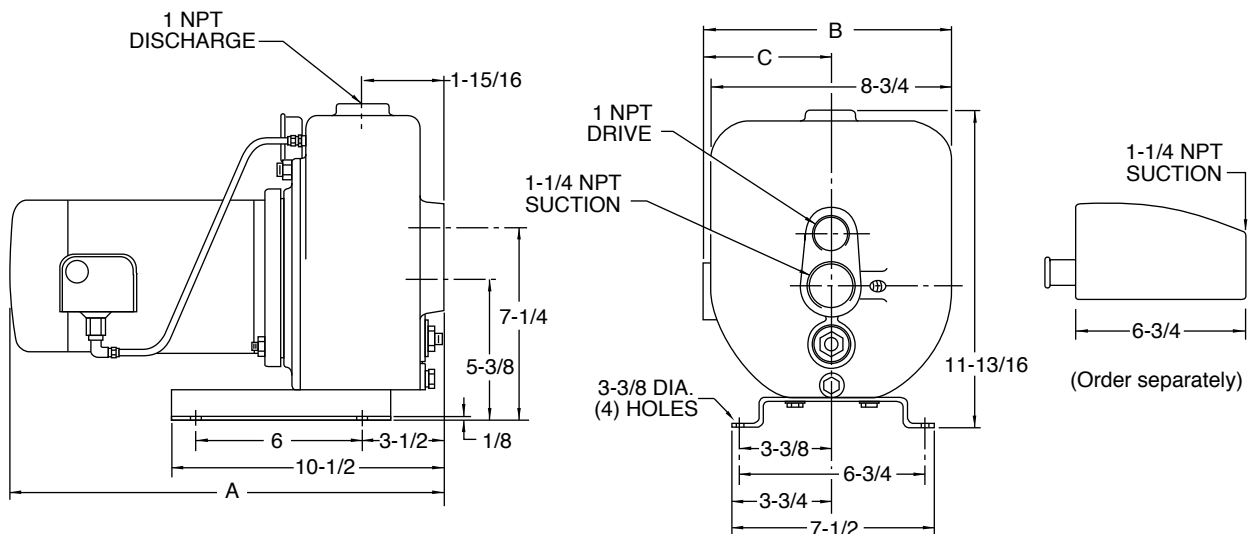

Dimensions (in inches) are for estimating purposes only.

# HMS Series

Cast iron, horizontal multi-stage

**PUMP PERFORMANCE** (Capacity in gallons per minute)  
**DEEP WELL 2" SINGLE PIPE: 40 PSI**

CAT. NO.	HP	JET NO.	USES VENTURI	USES NOZZLE	PUMPING DEPTH IN FEET															
					20'	30'	40'	50'	60'	70'	80'	90'	100'	110'	120'	130'	140'	150'	160'	
HMSD	3/4	13AP	J32P-26	J34P-44	12.0	10.8	9.6	8.1	6.9	5.5										
		22AP	J32P-22	J34P-43					7.9	6.7	5.5	4.7	3.9	3.0						
		8AP	J32P-18	J34P-42									4.0	3.6	3.1	2.7	2.2			
HMSE	1	5AP	J32P-29	J34P-41	16.3	15.6	14.1	12.0	9.9	8.2	6.0									
		4AP	J32P-24	J34P-41					8.9	7.9	7.0	5.8	4.7	3.6	2.5					
		19AP	J32P-20	J34P-43										4.0	3.2	2.3	1.8	1.3		
HMSE	1-1/2	15AP	J32P-33	J34P-41	20.0	18.5	17.0	13.6	10.4	7.6	5.0									
		9CP	J32P-26	J34P-41					10.6	9.2	8.0	6.0	4.5	3.7	3.0	2.2				
		23AP	J32P-20	J34P-44										4.3	3.5	2.7	2.4	2.0		

**DEEP WELL 3" SINGLE PIPE: 40 PSI**

HMSD	3/4	17CP	J32P-29	J34P-44	12.8	11.5	10.2	8.9	7.6	6.1									
		18CP	J32P-24	J34P-44					7.8	6.9	6.0	5.3	4.5	3.6					
		16CP	Factory Installed										5.0	4.4	3.9	3.4	3.0	2.5	2.0
HMSE	1	7CP	J32P-32	J34P-41	17.8	16.2	14.6	13.0	11.4	9.6	7.7								
		9CP	J32P-26	J34P-41					10.7	9.8	9.0	7.9	6.7	5.8	5.0	4.1			
HMSE	1-1/2	10CP	J32P-38	J34P-45	21.7	19.7	17.9	15.9	14.0	11.0	8.0								
		9CP	J32P-26	J34P-41					11.1	10.8	10.6	9.7	8.9	7.5	6.5	5.5			
		19CP	Factory Installed	J34P-41										6.9	6.1	5.3	4.6	4.1	

**DEEP WELL 4" DOUBLE PIPE: 40 PSI**

HMSD	3/4	CK2	J32P-29	J34P-44	12.8	11.5	10.2	8.9	7.6	6.1									
		CK2	J32P-24	J34P-44					7.8	6.9	6.0	5.3	4.5	3.6					
		15SD	Factory Installed										5.0	4.4	3.9	3.4	3.0	2.5	2.0
HMSE	1	CK3	J32P-32	J34P-41	17.8	16.2	14.6	13.0	11.4	9.6	7.7								
		CK3	J32P-26	J34P-41					10.7	9.8	9.0	7.9	6.7	5.8	5.0	4.1			
		CK1	J32P-20	J34P-43										5.0	4.5	3.9	3.5	3.0	
HMSE	1-1/2	CK4	J32P-38	J34P-45	21.7	19.7	17.9	15.9	14.0	11.0	8.0								
		CK3	J32P-26	J34P-41					11.1	10.8	10.6	9.7	8.9	7.5	6.5	5.5			
		4SD	Factory Installed											6.9	6.1	5.3	4.6	4.1	

Tested and rated in accordance with Water Systems Council Standards.

NOTE: Pumps installed with a Pro-Source® tank require a 100 PSI relief valve. Pumps installed with a conventional tank require a 75 PSI relief valve. Relief valve must be capable of relieving entire flow of pump at relief pressure.

**AUTOMATIC PRESSURE REGULATOR – DEEP WELL**

CATALOG NUMBER	DESCRIPTION	APPLICATION	APPROX. WT. LBS.
PKG 107	Regulator, tubing, pipe plug and compression fitting	Required for ALL deep well installations	4

# DMC Series

Cast iron, multi-stage centrifugal pump



The DMC Multi-Stage Centrifugal Pump offers heads to 175 feet and capacities to 50 GPM. Designed for the professional with heavy-duty cast iron pump case and seal plates and diffuser with Noryl® impellers for years of proven service. Available in 2 HP model.

## APPLICATIONS

- Residential Lawn Sprinkling
- Turf Irrigation
- Heat Pumps
- Water Transfer

## SPECIFICATIONS

- Pump Case:** Cast iron  
**Diffuser:** Reinforced polypropylene  
**Impellers:** Noryl®  
**Mechanical Shaft Seal, Type 6:** Buna-N, Carbon, Ceramic, 18-8 stainless steel  
**Mounting Base:** Steel

## FEATURES

- Rugged Construction:** Heavy-duty cast iron pump case and seal-plate.  
**Drain Port:** Provided for easy winterization.  
**Easy Serviceability:** Normal wearing parts are easily accessible for service and replacement, without disturbing piping.  
**Heavy-Duty Motors:** Designed for continuous operation.

## ORDERING INFORMATION

Catalog Number	HP	Suction	Pump/Motor Unit		Shallow Well Adapter	
			Discharge	Length	Approx. Wt. Lbs.	Approx. Wt. Lbs.
SINGLE PHASE - 115/230V*						
<b>DMC-2-200</b>	2*	1-1/4"	1"	20-7/8"	63	3
DMC SWITCH KIT - SK75						
Catalog Number				Approx. Wt. Lbs.		
66632				2		

\*2 HP available 230V only.

# DMC Series

Cast iron, multi-stage centrifugal pump

## PUMP PERFORMANCE

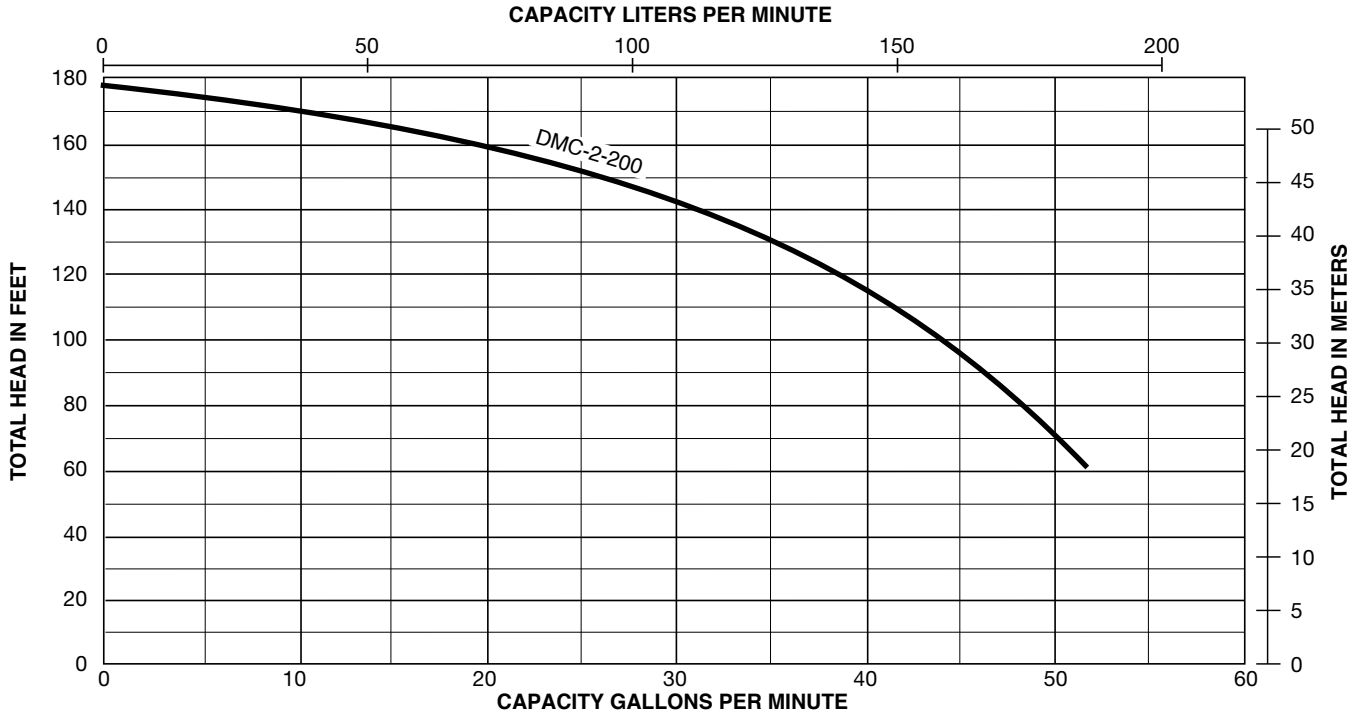

Catalog Number	HP	Discharge Pressure PSI	Depth to Water in Feet				
			5'	10'	15'	20'	25'
DMC-2-200	2	30	49	48	47	46	45
		40	44	43	42	40	39
		50	38	36	35	33	31
		60	30	27	24	21	15

Pumping capacities in gallons per minute at indicated discharge pressures in pounds per square inch.

## PUMP PERFORMANCE: SHALLOW WELL\*

Catalog Number	HP	Shallow Well Kit No.	Discharge Pressure PSI	Depth to Water in Feet				
				5'	10'	15'	20'	25'
DMC-2-SW 200	2	07657	20	21.3	18.8	16.6	15.0	11.4
			30	21.0	18.8	16.6	14.7	11.2
			40	21.0	18.4	16.3	14.7	11.2
			50	21.0	18.4	15.9	14.3	11.2
			60	19.3	18.4	15.8	14.3	11.2
			70	15.0	14.7	14.1	13.0	10.0

\*Shallow well adapter must be used (order separately).

# MS Series

Cast Iron



The MS Series Vertical Jet Pumps are the industry standard deep well jet pumps for over-the-well “bolt-on” installations.

The MS Series Jet Pumps include the pre-plumbed external automatic regulator, pressure gauge, pressure switch, and a complete line of casing adapters to drive the 4” double pipe or 2” and 3” single pipe jet packages.

## APPLICATIONS

Water systems and sprinkling...for homes, farms and cottages.

## SPECIFICATIONS

- Body:** Rugged cast iron
- Pump and Motor Shaft:** 416 stainless steel
- Impellers:** Noryl®
- Diffuser:** Close-grained cast iron

## FEATURES

**Automatic Pressure Regulator:** Faster-acting and quieter, design eliminates “hunting” for correct drive pressure. New, improved stem and guide are precisely molded to assure efficient, trouble-free performance on all deep wells.

**Quality Construction:** Precision-machined, close-grained cast iron pump body and base are specially treated to resist corrosion.

**Noryl Impellers:** Precision-molded for perfect balance, and ultra-smooth for highest performance and efficiency.

**Pressure Switch:** High quality. Differential and cut-in/cut-out pressure settings are adjustable.

**Motor Windings:** Superior insulation materials protect against excessive moisture and contaminants to ensure prolonged motor life.

**Mechanical Shaft Seal:** Precision-lapped and highly polished carbon-ceramic, stainless steel construction. Internal design guarantees continuous water lubrication for maximum protection.

**Dustproof Cover:** All electrical components are protected from dirt, dust and insects by a dustproof canopy. Ventilating air cannot contaminate vital switching components. This eliminates the most common cause of motor failure.

**Balanced Rotor:** Rotor is diecast under high pressures for uniform performance and greater efficiency...dynamically balanced.

**Heavy-Duty Ball Bearings:** Permanently lubricated sealed bearings are extensively tested to ensure extended life and smooth, quiet operation.

**Pump and Motor Shaft:** Stainless steel for maximum corrosion resistance; one-piece threaded shaft for positive impeller drive and alignment.

## ORDERING INFORMATION

CATALOG NUMBER	HP	DESCRIPTION	MAX. PRESS. REG. SETTING	PIPE TAPPING SIZES			MOTOR VOLTAGE	APPROX. WT. LBS.
				SUCT.	DRIVE	DISCH.		
MSD	3/4	Deep Well Jet	40 PSI	1-1/4"	1"	1"	115/230	67
MSE	1	Deep Well Jet	60 PSI	1-1/4"	1-1/4"	1"	115/230	73
MSF	1-1/2	Deep Well Jet	85 PSI	1-1/4"	1-1/4"	1"	230	120
MSG	2	Deep Well Jet	95 PSI	1-1/4"	1-1/4"	1"	230	125

## ADAPTER FLANGE

CATALOG NUMBER	DESCRIPTION	USED WITH
J216-26	1-1/4" x 1"	Offset single pipe, 4" double pipe through 3/4 HP
J216-27	1-1/4" x 1-1/4"	4" double pipe 1, 1-1/2 and 2 HP

Order pump from ordering information table above. A Jet Package should be ordered with every MS Series Pump. All installations require an appropriate size adapter flange or casing adapter if bolt-on feature is desired.

Pentair trademarks and logos are owned by Pentair plc or its affiliates. All other third party registered and unregistered trademarks and logos are the property of their respective owners.



# MS Series

Cast Iron

**PUMP PERFORMANCE** (Capacity in gallons per minute)  
**DEEP WELL (40 PSI) 2" SINGLE PIPE**

CAT. NO.	HP	JET NO.	USES VENTURI	USES NOZZLE	PUMPING DEPTH IN FEET																				MAX. PUMP SHUT-OFF PRESS. PSI	
					30'	40'	50'	60'	70'	80'	90'	100'	110'	120'	130'	140'	180'	200'	220'	240'	260'	JET AT MIN. DEPTH	JET AT MAX. DEPTH			
					MSD	3/4	12AP	J32P-24	J34P-42	10.0	8.3	6.1	4.7	3.8	2.0	1.4										
8AP	J32P-18	J34P-42	5.5	5.4			5.2	5.0	4.4	4.3	4.1	3.7	3.1	2.4	2.1	1.4							135	73		
MSE	1	12AP	J32P-24	J34P-42	12.1	11.3	11.2	10.0	8.8	7.6	6.5	5.6	3.3	1.8									118	80		
		8AP	J32P-18	J34P-42	5.5	5.5	5.3	5.3	5.2	5.1	5.0	5.0	5.0	5.0	4.5	4.2	2.0						198	126		
MSF	1-1/2	12AP	J32P-24	J34P-42	12.2	12.0	12.0	12.0	11.5	11.2	9.7	8.3	6.8	5.5	4.2	3.3							162	110		
		8AP	J32P-18	J34P-42	5.5	5.5	5.5	5.5	5.5	5.3	5.2	5.1	5.0	5.0	5.0	4.8	4.3	3.5	2.7	1.7			266	158		
MSG	2	12AP	J32P-24	J34P-42	12.2	12.0	12.0	12.0	11.7	11.2	11.0	10.3	8.3	7.5	6.3	5.3							193	139		
		8AP	J32P-18	J34P-42	5.5	5.5	5.5	5.5	5.5	5.3	5.2	5.2	5.1	5.1	5.0	4.8	4.7	4.3	3.7	3.2	2.5		312	192		

**PUMP PERFORMANCE** (Capacity in gallons per minute)  
**DEEP WELL (40 PSI) 3" SINGLE PIPE**

CAT. NO.	HP	JET NO.	USES VENTURI	USES NOZZLE	PUMPING DEPTH IN FEET																				MAX. PUMP SHUT-OFF PRESS. PSI	
					30'	40'	50'	60'	70'	80'	90'	100'	110'	120'	130'	140'	180'	200'	220'	240'	260'	280'	300'	320'	JET AT MIN. DEPTH	JET AT MAX. DEPTH
					MSD	3/4	23CP	J32P-24	J34P-42	10.2	8.4	6.8	5.8	4.5	3.1	2.1	1.1									
17CP	J32P-29	J34P-44	12.0	10.4			8.5	6.6	4.3	2.1														77	50	
16CP	J32P-18	J34P-42	5.5	5.4			5.3	5.2	4.7	4.3	4.1	3.7	3.1	2.7	2.3	1.9								137	75	
MSE	1	23CP	J32P-24	J34P-42	12.1	11.7	11.6	11.1	10.2	9.2	7.8	6.4	5.0	4.0	3.0								120	76		
		16CP	J32P-18	J34P-42	5.5	5.5	5.5	5.4	5.3	5.3	5.2	5.1	5.1	5.0	4.8	4.5	3.3	2.7	2.0	1.3	1.0			200	97	
MSF	1-1/2	23CP	J32P-24	J34P-42	12.2	12.2	12.2	12.2	11.7	11.3	10.7	9.9	9.0	8.3	7.0	4.0	1.3						164	95		
		22CP	J32P-20	J34P-42	7.7	7.7	7.7	7.5	7.5	7.4	7.3	7.3	7.2	7.2	7.0	7.0	4.3	4.0	3.2	2.2				210	110	
		16CP	J32P-18	J34P-42	5.5	5.5	5.5	5.5	5.5	5.5	5.3	5.2	5.2	5.1	5.0	5.0	4.9	4.7	4.0	3.8	3.0	2.3	1.7	268	132	
MSG	2	23CP	J32P-24	J34P-42	12.2	12.2	12.2	12.2	11.8	11.3	11.2	11.1	11.0	10.0	8.7	7.0	4.0	2.0						195	110	
		22CP	J32P-20	J34P-42	7.7	7.7	7.7	7.5	7.5	7.4	7.3	7.3	7.2	7.2	7.0	7.0	5.3	5.0	4.7	4.0	3.0	2.2		250	128	
		16CP	J32P-18	J34P-42	5.5	5.5	5.5	5.5	5.5	5.5	5.3	5.3	5.2	5.1	5.1	5.0	5.0	4.8	4.7	4.5	4.3	4.0	3.3	2.7	314	172

Tested and rated in accordance with Water Systems Council Standards.

NOTE: Pumps installed with a Pro-Source® tank require a 100 PSI relief valve. Pumps installed with a conventional tank require a 75 PSI relief valve. Relief valve must be capable of relieving entire flow of pump at relief pressure.

# SSJ Series

Cast Iron



The SSJ Series Vertical Jet Pumps are the industry standard deep well jet pumps for over-the-well “bolt-on” installations.

The SSJ Series Jet Pumps include the pre-plumbed external automatic regulator, pressure gauge, pressure switch, and a complete line of casing adapters to drive the 4” double pipe or 2” and 3” single pipe jet packages.

## APPLICATIONS

Water systems and sprinkling...for homes, farms and cottages.

## SPECIFICATIONS

**Body:** Rugged cast iron

**Pump and Motor Shaft:** Stainless steel

**Impellers:** Noryl®

**Diffuser:** Heavy-duty cast iron

## FEATURES

**Automatic Pressure Regulator:** Faster-acting, quieter design eliminates “hunting” for correct drive pressure. New, improved stem and guide are precisely molded to assure efficient, trouble-free performance on all deep wells.

**Quality Construction:** Precision-machined, close-grained cast iron pump body and base are specially treated to resist corrosion.

**Noryl Impellers:** Precision-molded for perfect balance, and ultra-smooth for highest performance and efficiency.

**Pressure Switch:** High quality. Differential and cut-in/cut-out pressure settings are adjustable.

**Dustproof Cover:** All electrical components are protected from dirt, dust and insects by a dustproof canopy. Ventilating air cannot contaminate vital switching components. This eliminates the most common cause of motor failure.

**Motor Windings:** Superior insulation materials protect against excessive moisture and contaminants to ensure prolonged motor life.

**Balanced Rotor:** Diecast under high pressures for uniform performance and greater efficiency...dynamically balanced.

**Heavy-Duty Ball Bearings:** Shielded, permanently lubricated bearings are extensively tested to ensure extended life and smooth, quiet operation.

**Pump and Motor Shaft:** Stainless steel for maximum corrosion resistance; one-piece threaded shaft for positive impeller drive and alignment.

## ORDERING INFORMATION

CATALOG NUMBER	HP	DESCRIPTION	PIPE TAPPING SIZES			MOTOR VOLTAGE	APPROX. WT. LBS.
			SUCT.	DRIVE	DISCH.		
SSJC	1/2	Deep Well Jet	1-1/4"	1"	1"	115/230	53
SSJD	3/4	Deep Well Jet	1-1/4"	1"	1"	115/230	63
SSJE	1	Deep Well Jet	1-1/4"	1"	1"	115/230	65

## ADAPTER FLANGE\*

CATALOG NUMBER	DESCRIPTION	USED WITH
J216-26	1-1/4" x 1"	Offset single pipe and 4" double pipe

\*Required for all 4” double pipe or offset installations.

NOTE: Order pump from ordering information table above. A Jet Package should be ordered with every SSJ Series Pump. All installations require an appropriate size adapter flange or casing adapter.

Pentair trademarks and logos are owned by Pentair plc or its affiliates. All other third party registered and unregistered trademarks and logos are the property of their respective owners.

# SSJ Series

Cast Iron

## OUTLINE DIMENSIONS

CAT. NO.	A
SSJC	14-1/2
SSJD	15-1/8
SSJE	16-3/16

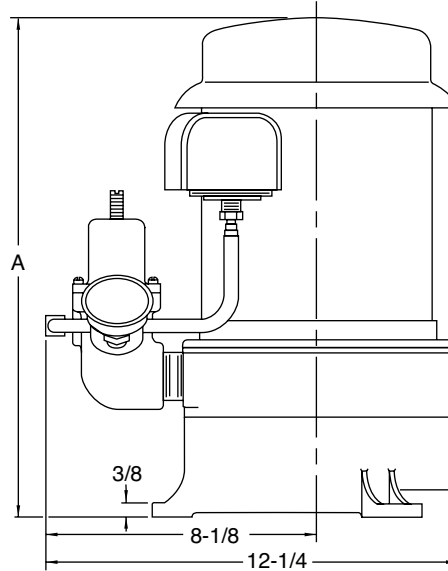

Dimensions (in inches) are for estimating purposes only.

## PUMP PERFORMANCE (Capacity in gallons per minute) DEEP WELL (40 PSI) 4" DOUBLE PIPE

CAT. NO.	HP	JET NO.	USES VENTURI	USES NOZZLE	PUMPING DEPTH IN FEET												MAX. PUMP SHUT-OFF PRESS. PSI	
					20'	30'	40'	50'	60'	70'	80'	90'	100'	110'	120'	130'	JET AT MIN. DEPTH	JET AT MAX. DEPTH
SSJC	1/2	15SD	J32P-18	J34P-42		4.8	4.3	3.7	3.0	2.4	1.8	1.5	1.0	0.5			91	50
		CK4	J32P-32	J34P-35	9.5	7.0	4.5	2.0									62	44
		4SD	J32P-24	J34P-41		6.5	5.1	4.0	3.0	1.8	0.8							75
SSJD	3/4	CK1	J32P-22	J34P-43		8.3	7.4	6.3	5.3	3.8	3.5	2.6	1.8	1.0			88	46
		CK3	J32P-32	J34P-41		10.0	6.4	3.0									57	46
		4SD	J32P-24	J34P-41		8.6	7.5	6.5	5.2	4.0	2.9	1.8	0.8				93	51
SSJE	1	CK1	J32P-22	J34P-43		8.6	7.8	6.6	5.6	4.5	3.6	2.8	2.3	1.7	1.1	0.6	98	47
		CK4	J32P-28	J34P-45		11.4	10.7	9.6	8.3	7.0	5.0	3.3	1.6				102	48
		CK4	J32P-38	J34P-45	17.0	13.2	9.5	5.8	2.2								66	44

Tested and rated in accordance with Water Systems Council Standards.

NOTE: Pumps installed with a Pro-Source® tank require a 100 PSI relief valve. Pumps installed with a conventional tank require a 75 PSI relief valve. Relief valve must be capable of relieving entire flow of pump at relief pressure.

# SSJ Series

Cast Iron

**PUMP PERFORMANCE** (Capacity in gallons per minute)  
**DEEP WELL (40 PSI) 2" SINGLE PIPE**

CAT. NO.	HP	JET NO.	USES VENTURI	USES NOZZLE	PUMPING DEPTH IN FEET													MAX. PUMP SHUT-OFF PRESS. PSI	
					20'	30'	40'	50'	60'	70'	80'	90'	100'	110'	120'	130'	JET AT MIN. DEPTH	JET AT MAX. DEPTH	
SSJC	1/2	14AP	J32P-32	J34P-45	9.2	6.7	4.3											61	49
		10AP	J32P-24	J34P-44		6.2	4.8	3.7	2.3	1.2								71	47
		8AP	J32P-18	J34P-42		4.1	3.7	3.1	2.6	2.1	1.6	1.2	0.8					94	53
SSJD	3/4	15AP	J32P-33	J34P-41	12.3	9.2	5.7											57	48
		9AP	J32P-29	J34P-44		10.6	7.4	4.7	2.3									64	47
		8AP	J32P-18	J34P-42		5.0	4.7	4.2	3.8	3.3	3.3	2.3	1.8	1.3				109	62
SSJE	1	16AP	J32P-38	J34P-45	15.3	11.8	8.5	5.2										65	48
		9AP	J32P-29	J34P-44		12.3	9.3	6.4	4.0									72	53
		8AP	J32P-18	J34P-42		5.7	5.0	4.6	4.2	3.7	3.3	2.8	2.4	1.8	1.3			124	66

**DEEP WELL (40 PSI) 3" SINGLE PIPE**

SSJC	1/2	19CP	J32P-24	J34P-41		6.5	5.1	4.0	3.0	1.8	0.8							75	45
		16CP	J32P-18	J34P-42		4.8	4.3	3.7	3.0	2.4	1.8	1.5	1.0	0.5				91	50
		11CP	J32P-32	J34P-45	9.5	7.0	4.5	2.0										62	44
SSJD	3/4	26CP	J32P-33	J34P-41	13.0	9.8	6.0											58	49
		19CP	J32P-24	J34P-41		8.6	7.5	6.5	5.2	4.0	2.9	1.8	0.8					93	51
		17CP	J32P-29	J34P-44		11.5	8.0	5.2	2.6									66	48
		15CP	J32P-22	J34P-43		8.3	7.4	6.3	5.3	3.8	3.5	2.6	1.8	0.1				88	46
SSJE	1	19CP	J32P-24	J34P-41		7.9	7.5	7.2	6.5	5.6	4.4	2.8						105	69
		15CP	J32P-22	J34P-43		8.6	7.8	6.6	5.6	4.5	3.6	2.8	2.3	1.7	1.1	0.6		98	47
		10CP	J32P-38	J34P-45	17.0	13.2	9.5	5.8	2.2									66	44

Tested and rated in accordance with Water Systems Council Standards.

NOTE: Pumps installed with a Pro-Source® tank require a 100 PSI relief valve. Pumps installed with a conventional tank require a 75 PSI relief valve. Relief valve must be capable of relieving entire flow of pump at relief pressure.

# Intelliboost® R Series

Multi-stage variable frequency drive booster pump



The Sta-Rite® Intelliboost® is the only TRUE variable speed booster with an LCD screen that gives you an easy to use, all-in-one solution for not only boosting, but also delivering a constant pressure throughout the system. This dependable unit quickly enhances your customer's system with smart controls that adjusts to their water usage.

## APPLICATIONS

- Residential Boosting
- Water Transfer
- Turf Irrigation

## SPECIFICATIONS

- Pump Case:** Stainless Steel  
**Diffuser:** Reinforced Polypropylene  
**Impeller:** Reinforced Polypropylene  
**Mechanical Shaft Seal:** Carbon, Ceramic, Stainless Steel  
**Mounting Base:** Steel

## FEATURES

- TRUE Variable Speed:** The Intelliboost features a variable speed control that adjusts itself as demand changes to hold water pressure (up to 60psi) at the desired level.
- All-In-One Unit:** Includes pump, variable speed drive and tank all in one unit for quick and easy install.
- Simple Startup:** Unit is preset to boost 60psi, allowing you to plumb it, wire it, power up and go!
- Built-in Check Valve:** Includes a check valve after the discharge to further protect your system.
- LCD Screen:** No blinking lights! The Intelliboost has an easy-to-read LCD screen that tells you the status of your unit in plain text.

## ORDERING INFORMATION

Catalog Number	HP	Input Voltage	Phase	Pipe Tapping Size		Approx. Wt. Lbs.
				Suction	Discharge	
MIB0715S	3/4	230	1	1"	1"	30

# Intelliboost® R Series

Multi-stage variable frequency drive booster pump

## PUMP PERFORMANCE

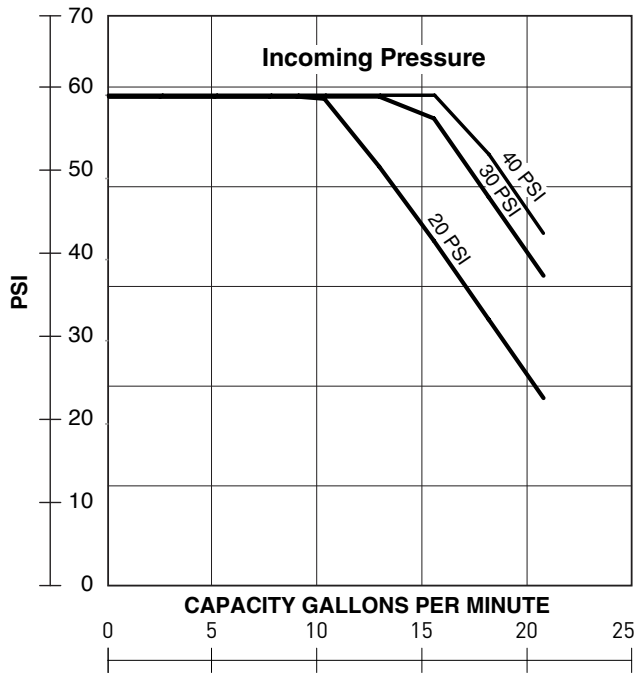

Incoming Household Pressure	Booster Set At:	
	50 PSI	60 PSI
20 PSI	<b>Boosted Household Pressure</b>	
	50 PSI	60 PSI
30 PSI	<b>Household Water Usage</b>	
	Up to 13 GPM	Up to 10 GPM
40 PSI	<b>Boosted Household Pressure</b>	
	50 PSI	60 PSI
40 PSI	<b>Household Water Usage</b>	
	Up to 21 GPM	Up to 19 GPM

## OUTLINE DIMENSIONS

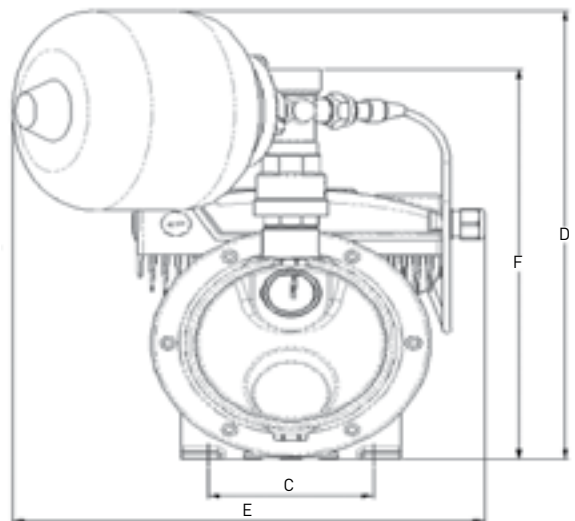
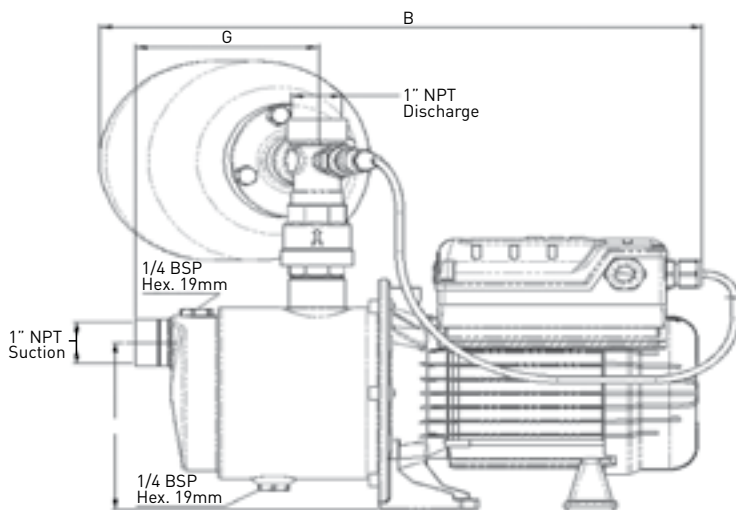

Dimensions (inch)

A	B	C	D	E	F	G
5.1	15.0	3.9	13.7	11.8	12.0	4.6

# HP/HPS Series Signature 2000®

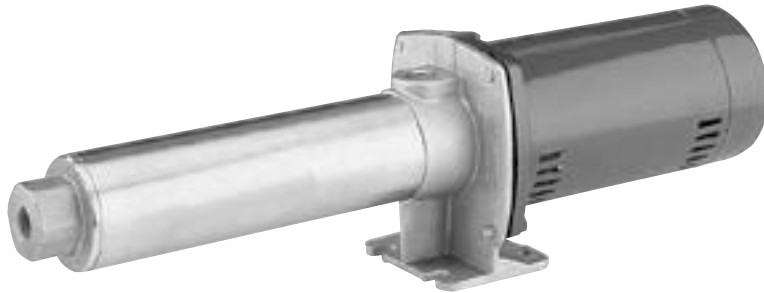

The HP/HPS Booster Pumps are the most durable booster pump available. The proven **SignaSeal™** floating impeller design minimizes thrust loads allowing for continuous operation without damage to motor bearings, mechanical seal or pump hydraulic components.

## APPLICATIONS

- Car wash
- Filtration and reverse osmosis
- Residential, commercial or agricultural pressure washing
- Booster and spray systems
- HVAC
- General purpose pumping

## SPECIFICATIONS

- Max. Inlet Pressure:** 80 PSI
- Max. Working Pressure:** 315 PSI
- Max. Suction Lift:** 15 feet
- Maximum Limits:** Prolonged use with liquids above 140°F is not recommended.
- Discharge:**
  - HP Series:** cast iron
  - HPS Series:** stainless steel
- Motor Adapter and Base:**
  - HP Series:** cast iron
  - HPS Series:** stainless steel
- Shell:** Stainless steel 304 grade
- Impeller:** Acetal
- Diffuser:** Polycarbonate
- Shaft:** Stainless steel 304 grade
- O-Rings:** Buna-N
- Mechanical Seal:** Carbon/ceramic, Buna-N

## FEATURES

**SignaSeal Staging System:** The proven SignaSeal staging system utilizes a ceramic wear surface that, when incorporated with Sta-Rite's "true" independent floating impellers, dominates with 1st-in-class performance, superior sand handling and thrust management staging system.

**Acetal Impellers:** Precision-molded for perfect balance...ultra-smooth for highest performance and efficiency.

**Precision-Molded Diffusers:** Superior performance with high resistance to corrosion and abrasion.

**Mechanical Shaft Seal:** Precision lapped and highly polished carbon-ceramic, stainless steel construction. Internal design guarantees continuous water lubrication.

**Motor Windings:** Superior insulation materials protect against excessive moisture and contaminants...assure prolonged motor life.

**Balanced Rotor:** Diecast under high pressures for uniform performance and greater efficiency; dynamically balanced.

**Heavy-Duty Ball Bearings:** Shielded, permanently lubricated bearings, extensively tested to ensure extended life and smooth, quiet operation.

**Pump and Motor Shaft:** Stainless steel for maximum corrosion resistance; one-piece threaded shaft for positive impeller drive.

**Dustproof Cover:** All electrical components are protected from dirt, dust and insects by a dustproof canopy; ventilating air cannot contaminate.

**TEFC Models available.** Contact Customer Service.

# HP/HPS Series Signature 2000®

**ORDERING INFORMATION**

Catalog Number		GPM	HP	Phase	Stages	Pipe Tapping Sizes		Motor Voltage	Shipping Wt. (Lbs.)	
Cast Iron	Stainless Steel					Suction	Discharge			
HP7C	HPS7C	7	1/2	1	9	3/4"	3/4"	115/230	48	
HP7C3	HPS7C3		1/2	3	9	3/4"	3/4"	208-230/460	45	
HP7D	HPS7D		3/4	1	12	3/4"	3/4"	115/230	48	
HP7D3	HPS7D3		3/4	3	12	3/4"	3/4"	208-230/460	45	
HP7E	HPS7E		1	1	16	3/4"	3/4"	115/230	51	
HP7E3	HPS7E3		1	3	16	3/4"	3/4"	208-230/460	48	
HP10C	HPS10C	10	1/2	1	6	3/4"	3/4"	115/230	45	
HP10C3	HPS10C3		1/2	3	6	3/4"	3/4"	208-230/460	42	
HP10D	HPS10D		3/4	1	8	3/4"	3/4"	115/230	46	
HP10D3	HPS10D3		3/4	3	8	3/4"	3/4"	208-230/460	43	
HP10E	HPS10E		1	1	10	3/4"	3/4"	115/230	50	
HP10E3	HPS10E3		1	3	10	3/4"	3/4"	208-230/460	47	
HP10F	HPS10F		1-1/2	1	14	3/4"	3/4"	115/230*	58	
HP10F3	HPS10F3		1-1/2	3	14	3/4"	3/4"	208-230/460	53	
HP10G	HPS10G		2	1	16	3/4"	3/4"	115/230*	63	
HP10G3	HPS10G3		2	3	16	3/4"	3/4"	208-230/460	59	
HP20E	HPS20E		20	1	1	7	1"	1"	115/230	49
HP20E3	HPS20E3			1	3	7	1"	1"	208-230/460	46
HP20F	HPS20F	1-1/2		1	9	1"	1"	115/230*	57	
HP20F3	HPS20F3	1-1/2		3	9	1"	1"	208-230/460	52	
HP20G	HPS20G	2		1	11	1"	1"	115/230*	62	
HP20G3	HPS20G3	2		3	11	1"	1"	208-230/460	58	
HP20HG	HPS20HG	2-1/2		1	13	1"	1"	115/230*	58	
HP20HG3	HPS20HG3	2-1/2		3	13	1"	1"	208-230/460	54	
HP20H	HPS20H	3		1	15	1"	1"	208/230	59	
HP20H3	HPS20H3	3		3	15	1"	1"	200-230/460	55	
HP30E	HPS30E	30		1	1	5	1-1/4"	1-1/4"	115/230	47
HP30E3	HPS30E3			1	3	5	1-1/4"	1-1/4"	208-230/460	44
HP30F	HPS30F		1-1/2	1	6	1-1/4"	1-1/4"	115/230*	54	
HP30F3	HPS30F3		1-1/2	3	6	1-1/4"	1-1/4"	208-230/460	49	
HP30G	HPS30G		2	1	7	1-1/4"	1-1/4"	115/230*	57	
HP30G3	HPS30G3		2	3	7	1-1/4"	1-1/4"	208-230/460	53	
HP30HG	HPS30HG		2-1/2	1	9	1-1/4"	1-1/4"	115/230*	69	
HP30HG3	HPS30HG3		2-1/2	3	9	1-1/4"	1-1/4"	208-230/460	54	
HP30H	HPS30H		3	1	11	1-1/4"	1-1/4"	208/230	59	
HP30H3	HPS30H3		3	3	11	1-1/4"	1-1/4"	200-230/460	55	

Note: ODP motor is standard; for TEFC motors, contact Customer Service.

\*HPS models 230V only.

**ORDERING INFORMATION (ACCESSORIES)**

Pkg. No.	Description	Approx. Wt. Lbs.
<b>SUCTION</b>		
83	Suction hose – 3/4" 150 PSI hose, 6 ft. section with two (2) female hose fittings	3
85	Two (2) garden hose/NPT adapters – 3/4" NPT male to 3/4" garden hose male	3
<b>150 PSI RATED* DISCHARGE</b>		
84	Discharge hose – 3/4" 150 PSI hose, 25 ft. section with male and female garden hose fittings	10
86	High-pressure pistol-grip nozzle with three (3) nozzles (No. 56, 50 and 49)	2

\*To select proper discharge accessories for your pump, add incoming pressure to pump output pressure, to determine total discharge pressure.

Example: Incoming pressure 20 PSI + pump output pressure (HP7C at 0 GPM, 300') 87 PSI = Total 150 PSI at discharge = 150 PSI rated discharge accessories

# HP/HPS Series Signature 2000®

## PUMP PERFORMANCE: 7 GPM

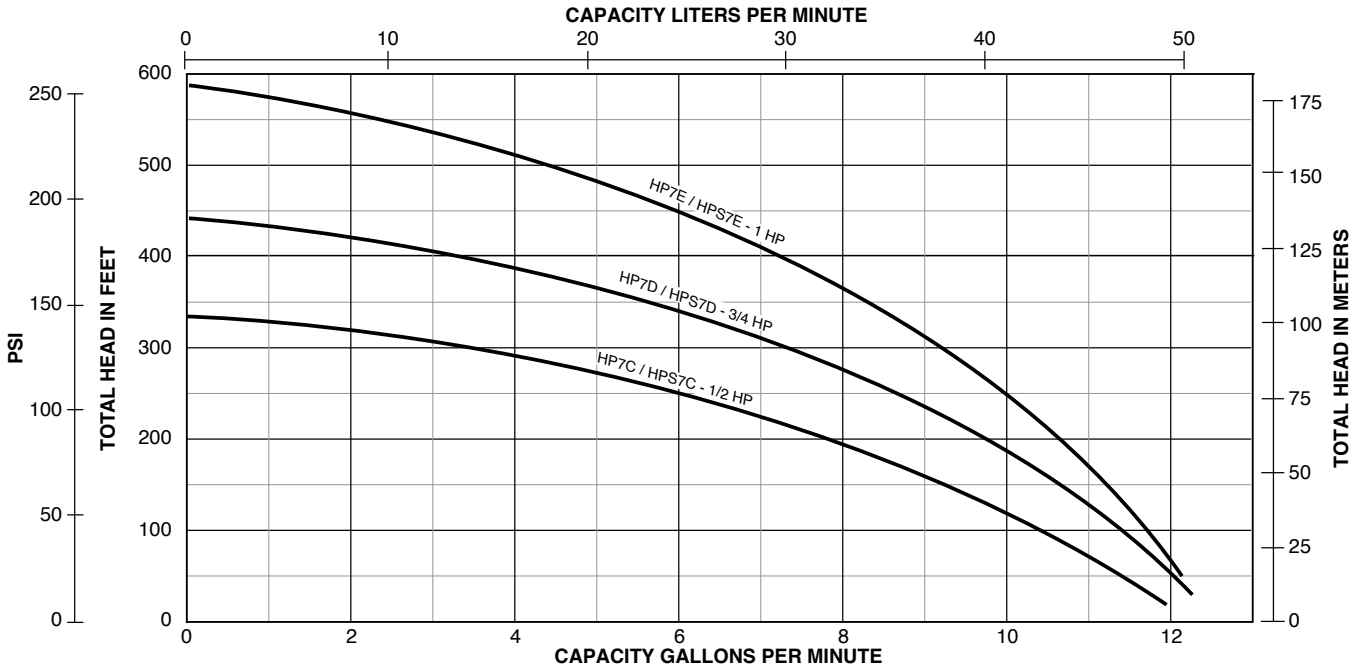

## PUMP PERFORMANCE: 10 GPM

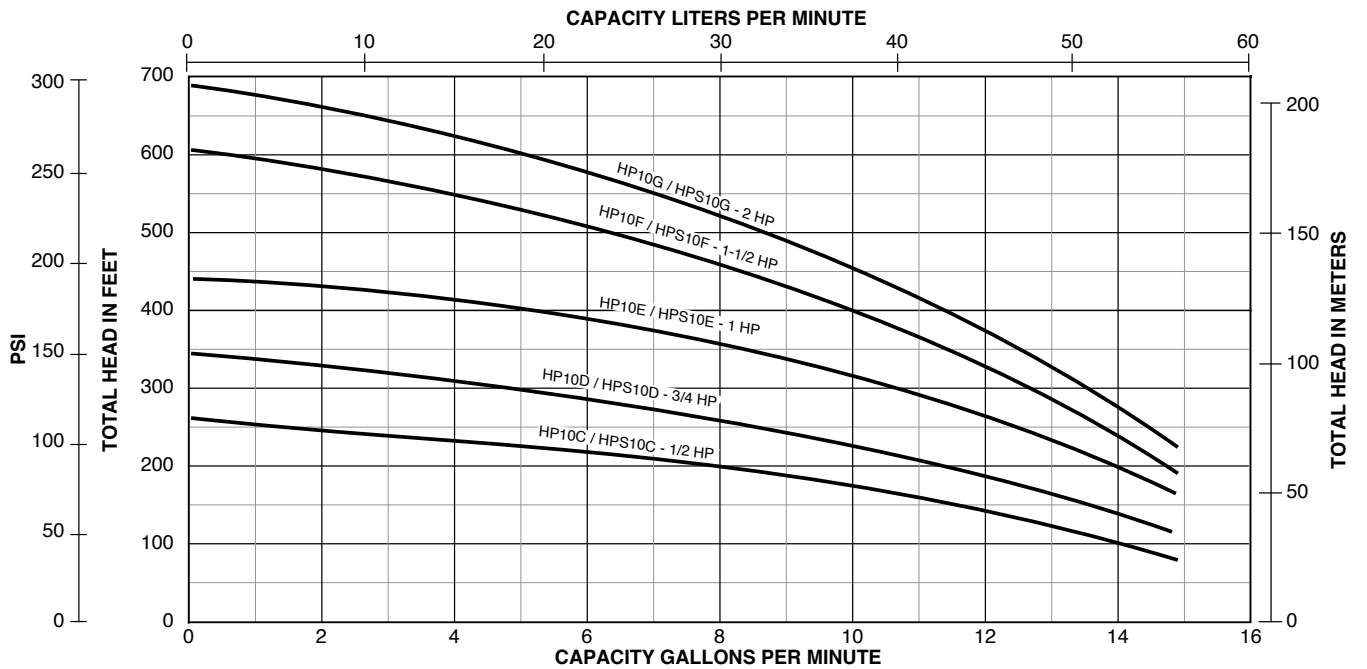

# HP/HPS Series Signature 2000®

## PUMP PERFORMANCE: 20 GPM

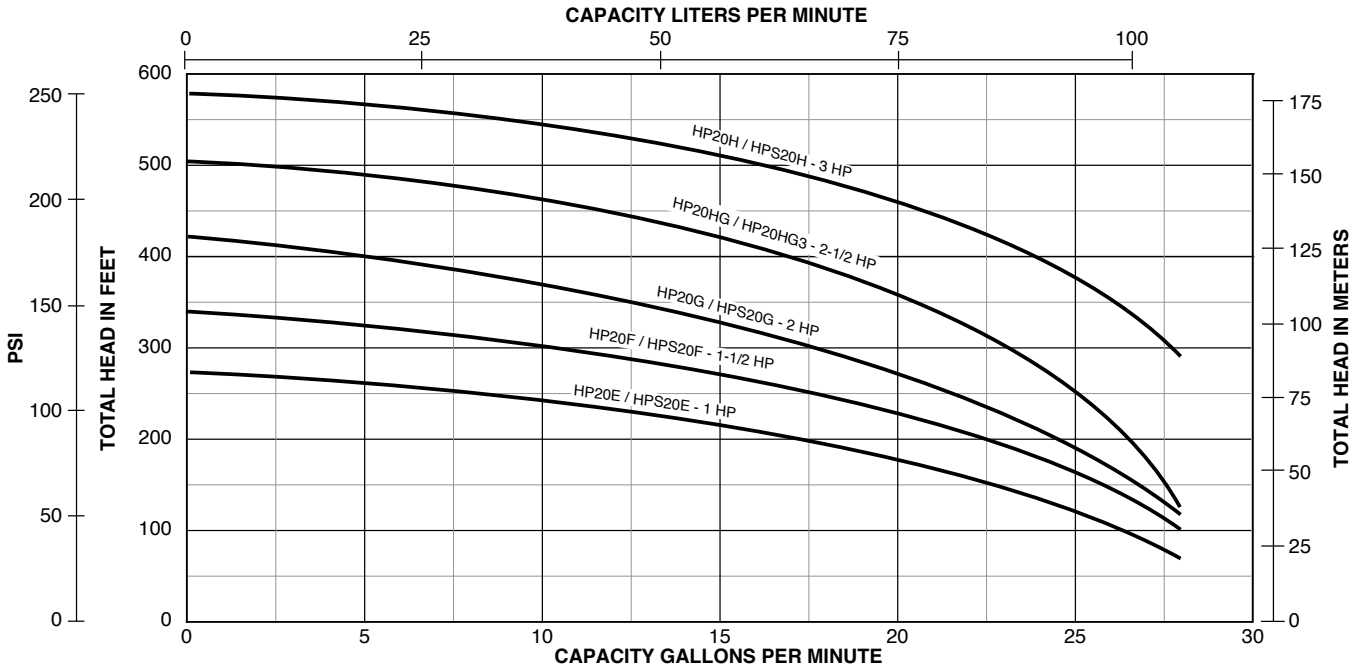

## PUMP PERFORMANCE: 30 GPM

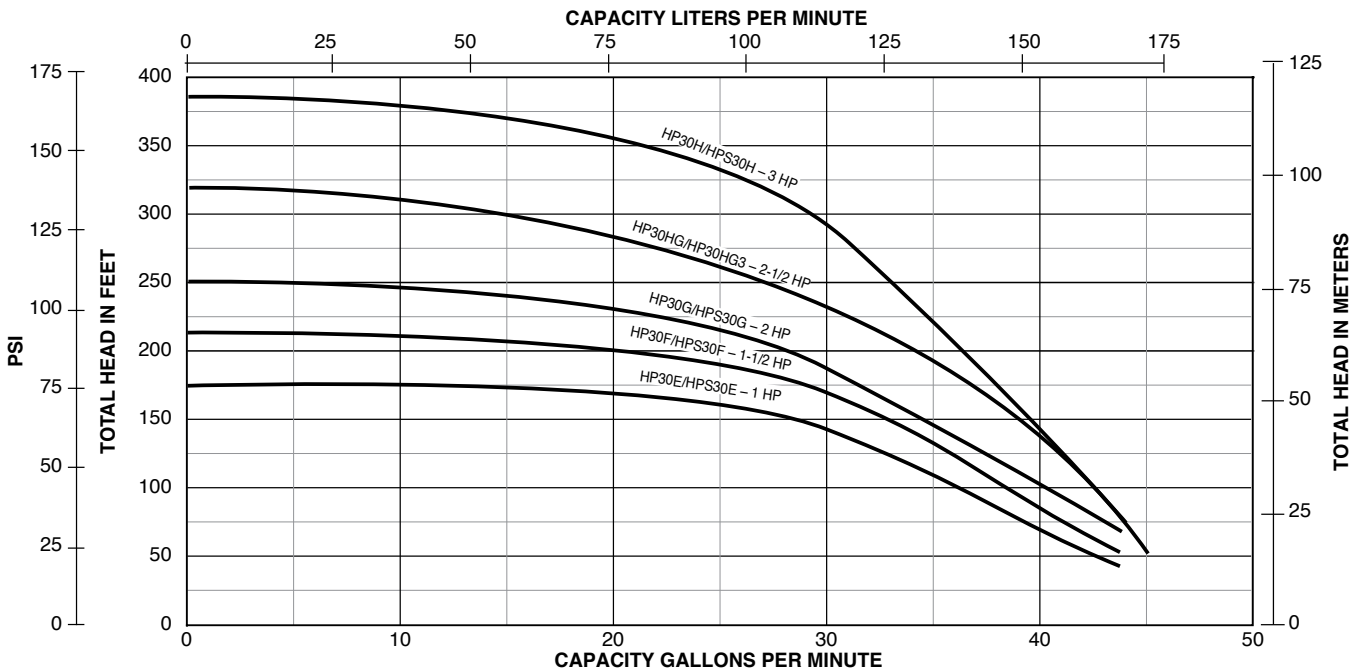

# HP/HPS Series Signature 2000®

## OUTLINE DIMENSIONS

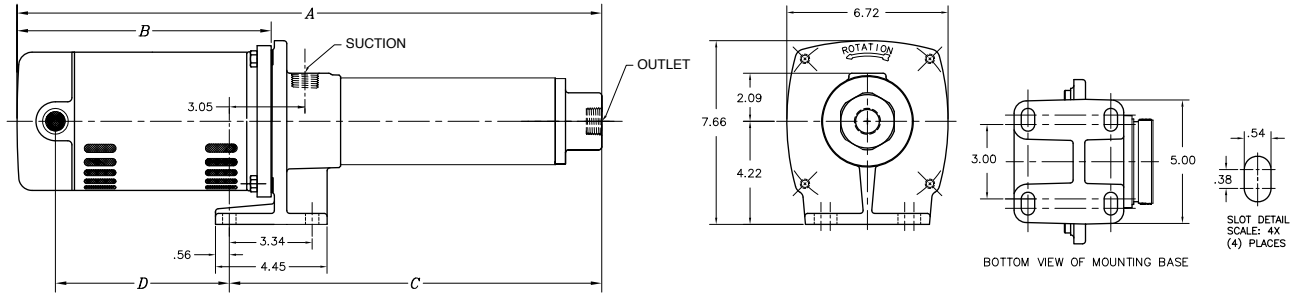

### DIMENSIONS: CAST IRON (IN INCHES)

Catalog Number	HP	A	B	C	D
HP7C	1/2	24.60	10.38	15.76	6.88
HP7C3	1/2	23.34	9.12	15.76	7.88
HP7D	3/4	27.73	10.88	18.39	7.88
HP7D3	3/4	27.22	10.38	18.39	7.47
HP7E	1	32.23	11.88	21.89	8.88
HP7E3	1	31.23	10.88	21.89	7.88
HP10C	1/2	23.19	11.60	13.13	8.63
HP10C3	1/2	20.71	9.12	13.13	6.88
HP10D	3/4	25.31	11.97	14.88	9.00
HP10D3	3/4	23.71	10.38	14.88	7.47
HP10E	1	28.12	13.03	16.63	10.06
HP10E3	1	25.97	10.88	16.63	7.88
HP10F	1-1/2	32.07	13.47	20.14	10.50
HP10F3	1-1/2	30.47	11.88	20.14	8.88
HP10G	2	34.13	13.78	21.89	10.81
HP10G3	2	32.97	12.63	21.89	9.63
HP20E	1	26.02	11.88	15.68	8.88
HP20E3	1	25.02	10.88	15.68	7.88
HP20F	1-1/2	29.84	13.47	17.91	10.50
HP20F3	1-1/2	28.24	11.88	17.91	8.88
HP20G	2	32.38	13.78	20.14	10.81
HP20G3	2	31.22	12.63	20.14	9.63
HP20HG	2-1/2	33.82	13.18	22.36	10.25
HP20HG3	2-1/2	33.84	13.20	22.36	10.28
HP20H	3	36.80	14.05	24.47	11.12
HP20H3	3	34.67	11.92	24.47	8.97
HP30E	1	25.08	11.88	14.92	8.69
HP30E3	1	24.08	10.88	14.92	7.69
HP30F	1-1/2	27.26	12.63	16.35	9.44
HP30F3	1-1/2	26.51	11.88	16.35	8.69
HP30G	2	28.49	12.42	17.79	9.47
HP30G3	2	28.70	12.63	17.79	9.44
HP30HG	2-1/2	32.24	13.18	20.78	10.25
HP30HG3	2-1/2	32.26	13.20	20.78	10.28
HP30H	3	35.86	14.05	23.53	11.12
HP30H3	3	33.73	11.92	23.53	8.97

### DIMENSIONS: STAINLESS STEEL (IN INCHES)

Catalog Number	HP	A	B	C	D
HPS7C	1/2	25.82	11.60	15.76	8.63
HPS7C3	1/2	23.84	9.12	15.76	6.88
HPS7D	3/4	28.82	11.97	18.39	9.00
HPS7D3	3/4	27.22	10.38	18.39	7.47
HPS7E	1	33.38	13.03	21.89	10.06
HPS7E3	1	31.23	10.88	21.89	7.88
HPS10C	1/2	23.19	11.60	13.13	8.63
HPS10C3	1/2	20.71	9.12	13.13	6.88
HPS10D	3/4	25.31	11.97	14.88	9.00
HPS10D3	3/4	23.71	10.38	14.88	7.47
HPS10E	1	28.12	13.03	16.63	10.06
HPS10E3	1	25.97	10.88	16.63	7.88
HPS10F	1-1/2	32.07	13.47	20.14	10.50
HPS10F3	1-1/2	30.47	11.88	20.14	8.88
HPS10G	2	34.13	13.78	21.89	10.81
HPS10G3	2	32.97	12.63	21.89	9.63
HPS20E	1	26.05	13.03	14.56	10.06
HPS20E3	1	23.90	10.88	14.56	7.88
HPS20F	1-1/2	29.84	13.47	17.91	10.50
HPS20F3	1-1/2	28.24	11.88	17.91	8.88
HPS20G	2	32.38	13.78	20.14	10.81
HPS20G3	2	31.22	12.63	20.14	9.63
HPS20HG	2-1/2	33.82	13.18	22.36	10.28
HPS20HG3	2-1/2	33.84	13.20	22.36	10.28
HPS20H	3	36.80	14.05	24.47	11.12
HPS20H3	3	34.67	11.92	24.47	8.97
HPS30E	1	26.23	13.03	14.92	9.87
HPS30E3	1	24.08	10.88	14.92	7.69
HPS30F	1-1/2	28.10	13.47	16.35	10.31
HPS30F3	1-1/2	26.51	11.88	16.35	8.69
HPS30G	2	29.85	13.78	17.79	10.62
HPS30G3	2	28.70	12.63	17.79	9.44
HPS30HG	2-1/2	32.24	13.18	20.78	10.28
HPS30HG3	2-1/2	32.26	13.20	20.78	10.28
HPS30H	3	35.86	14.05	23.53	11.12
HPS30H3	3	33.73	11.92	23.53	8.97

# Jet Packages & Accessories

A jet package should be ordered with every convertible deep well jet pump.

## ORDERING INFORMATION

Package	Jet Number	Used with Pump Series
<b>SHALLOW WELL AND 4" DEEP WELL DOUBLE PIPE</b>		
<b>PKG 1 - [ ] [ ] SD</b>  For shallow well applications  For all 4" double pipe applications	PKG 1-4SD	SL, HL, FL, HMS
	PKG 1-10SD	SL, HL, FL, HMS
	PKG 1-11SD	SL, HL, FL, HMS
	PKG 1-12SD	SL, HL, FL, HMS
	PKG 1-15SD	SL, HL, FL, HMS
	PKG 1-23SD	MS, PL
	PKG 1-27SD	SL, HL, FL
	PKG 1-29SD	SL, HL, FL, HMS
	PKG 1-54SD	SL, HL, FL
	PKG 1-55SD	SL, HL, FL
PKG 1-60SD	SL, HL	
<b>SHALLOW WELL AND 4" DEEP WELL DOUBLE PIPE - KITS</b>		
<b>PKG CK [ ]</b>  Same as SD jets above, with three (3) venturis	PKG CK1	SL, HL, HMS, SSJ
	PKG CK2	SL, HL, HMS, SSJ
	PKG CK3	SL, HL, HMS, SSJ, FL
	PKG CK4	HMS, SSJ
	PKG CK5	SL, HL, HMS, SSJ
<b>4" DEEP WELL DOUBLE PIPE WITH ACCESSORY PACKAGES</b>		
<b>PKG 2A - [ ] [ ] SD</b>	PKG 2A-4SD	SL, HL, FL, HMS
	PKG 2A-15SD	SL, HL, FL, HMS
	PKG 2A-23SD	MS, PL
	PKG 2A-54SD	SL, HL, FL
	PKG 2A-55SD	SL, HL, FL
<b>PL SERIES PLASTIC SHALLOW WELL JET PACKAGES</b>		
<b>PKG 1 - [ ] [ ] N</b>  For all shallow well applications	PKG 1-21N	PL
	PKG 1-22N	PL
	PKG 1-23N	PL
	PKG 1-24N	PL

Continued On Next Page.

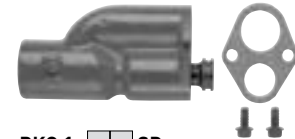

**PKG 1- [ ] [ ] SD**  
SHALLOW WELL & DEEP WELL

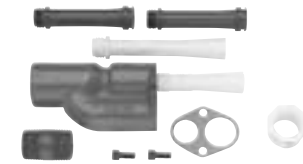

**PKG CK [ ]**

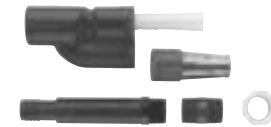

**PKG 2A- [ ] [ ] SD**  
DOUBLE PIPE



**PKG 1- [ ] [ ] N**  
PL SHALLOW WELL



**PKG 2A**  
ACCESSORY PACKAGE

## ORDERING INFORMATION

ACCESSORY PACKAGE		
Catalog Number	Description	Approx. Wt. Lbs.
PKG 2A	Poly Pipe and Foot Valve Kit (1-1/4" Brass)	3

# Jet Packages & Accessories

A jet package should be ordered with every convertible deep well jet pump.

## ORDERING INFORMATION (CONT'D.)

Package	Jet Number	Suction Tapping	Used with Pump Series
<b>2" SINGLE PIPE*</b>			
<b>PKG 1**-</b> <input type="checkbox"/> <input type="checkbox"/> <b>AP</b> <b>PKG 1-</b> <input type="checkbox"/> <input type="checkbox"/> <b>APB</b> (4 lbs.)  Jet with built-in check valve  For all 2" single pipe deep well applications	PKG 1-54 AP	<b>1-1/4" M and 1" F</b>	SL, HL, FL
	PKG 1-23 AP		HMS
	PKG 1-22 AP		HMS
	PKG 1-18 AP		HMS
	PKG 1-19 AP		HMS
	PKG 1-16 AP & APB		PL, SSJ
	PKG 1-15 AP		PL, HMS, SSJ
	PKG 1-14 AP		PL, SSJ
	PKG 1-13 AP		PL, HMS
	PKG 1-12 AP & APB		MS
	PKG 1-10 AP & APB		SL, HL, PL, SSJ
	PKG 1-9 AP & APB		SL, HL, PL, SSJ
	PKG 1-8 AP & APB		SL, HL, PL, HMS, SSJ, MS, FL
	PKG 1-7 AP & APB		HMS
	PKG 1-5 AP		HMS
PKG 1-4 AP	HMS		
PKG 1-2 AP	HMS		
<b>3" SINGLE PIPE</b>			
<b>PKG 1**</b> <input type="checkbox"/> <input type="checkbox"/> <b>CP</b> (6 lbs.)  Jet with built-in check valve  For all 3" single pipe deep well applications	PKG 1-57 CP	<b>1-1/4" M and 1" F</b>	SL, HL
	PKG 1-54 CP		SL, HL, FL
	PKG 1-26 CP		PL, SSJ
	PKG 1-25 CP		PL
	PKG 1-23 CP		MS
	PKG 1-22 CP		HMS, MS
	PKG 1-19 CP		SL, HL, PL, HMS, SSJ, FL
	PKG 1-18 CP		SL, HL, HMS
	PKG 1-17 CP		PL, HMS, SSJ, MS
	PKG 1-16 CP		SL, HL, HMS, SSJ, MS, FL
	PKG 1-15 CP		PL, SSJ
	PKG 1-11 CP		PL, SSJ
	PKG 1-10 CP		PL, HMS
	PKG 1-9 CP		SL, HL, HMS, FL
	PKG 1-7 CP		HMS



**PKG 1-**   **AP**  
2" SINGLE PIPE CAST IRON

OR

**PKG 1-**   **APB**  
2" SINGLE PIPE BRASS

**PKG 1-**   **CP**  
3" SINGLE PIPE

\*Order one (1) U11-1 turned coupling for each length of drop pipe.

\*\*For casing adapter, please see following page.

## ORDERING INFORMATION

TURNED COUPLING		
Catalog Number	Description	Approx. Wt. Lbs.
U11-1	Turned Coupling (1-1/4" NPT)	1



**PKG U11-1**  
TURNED COUPLING

# Jet Packages & Accessories



**View A**  
Vertical - Straight Offset  
Casing Adapter



**View B**  
Vertical - Bolt-on  
Casing Adapter



**View C**  
Horizontal - Right Angle  
Casing Adapter  
Drive-Over-Suction



**View D**  
Horizontal - Right Angle  
Casing Adapter  
Suction-Over-Drive

## ACCESSORIES

Catalog Number	View	Description	Approx. Wt. Lbs.	Use with Pump Series
<b>CASING ADAPTERS</b>				
J216-13A	A	2" vertical - straight offset	6	General Usage
J216-21	B	2" vertical - bolt-on	6	SSJ, MS
J216-23	B	3" vertical - bolt-on	7	SSJ, MS
J216-16A	C	2" horizontal - right angle - drive-over-suction	7	FL, HMS
J216-18A	C	3" horizontal - right angle - drive-over-suction	9	FL, HMS
J37-4	-	Offset nipple (1" NPT x 4-3/4")	1	General Usage
J216-29B	-	2" concentric pipe - pitless adapter	6	SSJ, MS
J216-42	-	2" concentric pipe - pitless adapter	6	FL, HMS
J216-44	D	2" horizontal - right angle - suction-over-drive	7	SL, HL
<b>FOOT VALVES</b>				
U212-28	E	3/4" foot valve and strainer	1	
U212-93	E	1" foot valve and strainer	1	
U212-94	E	1-1/4" foot valve and strainer	2	
U212-92	E	1-1/2" foot valve and strainer	3	
U212-16	E	2" foot valve and strainer	3	
<b>PRESSURE REGULATOR</b>				
PKG 107	F	Regulator, tubing, pipe plug and compression fitting	4	

**View E**  
Foot  
Valves



**View F**  
Pressure  
Regulator



# Jet Packages & Accessories

## ACCESSORIES (CONT'D.)

AIR VOLUME CONTROLS		
Catalog Number	Description	Approx. Wt. Lbs.
U238-5A	Sta-Rite AVC, 1/4" compression fitting for copper tube, nipple, instruction sheet, jet type	1
U238-5B	Sta-Rite AVC, 1/4" compression fitting for plastic tube, nipple, instruction sheet, jet type	1
J238-10B	Sta-Rite AVC, 1/4" plastic tubing, compression fittings, reducer bushing and instruction sheet	3
E238-2	Air volume control – submersible	1
U238-4	AVC bulk. No fittings.	1
U238-5E	AVC boxed. No fittings or nipple.	1
U78-774P	Plastic AVC reducer bushing, 1-1/4" x 1/4"	1
TANK MOUNTING PACKAGES –PRO-SOURCE® TANKS		
PKG 111	For tank mounting PL and PN Series jet pumps	2
PKG 112	For tank mounting HN, SN, FN, HL, SL, and FL Series Jet Pumps	2
PKG 198	Jet Pump to Tank Mounting Bracket	3
PKG 207	Pump-to-Tank Fitting Package – all galvanized fittings	4
REVERSING ADAPTER		
PKG 108	Adapter, gasket, capscrews, 1" x 1-1/4"	4
PRESSURE GAUGES		
U239-2	Pressure gauge, bottom mount 1/4", 0-100 PSI	1
U239-3	Pressure gauge, bottom mount 1/8", 0-100 PSI	1
U239-3A	U239-3 with 1/4" x 1/8" reducer bushing	1
U239-8	Pressure gauge, bottom mount 1/4", 0-200 PSI	1
U78-107DT	Reducer bushing for U239-3 1/4" x 1/8"	1



**U238-5**  
Air Volume Controls  
(Jet pump type)

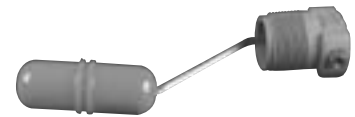

**E238-2**  
Air Volume Control  
(Submersible type)



**Reducer Bushing**



**Tank Mounting Packages**



**PKG 108**  
Reversing Adapter  
Drive over suction to suction over drive



**PKG 198**  
Universal Jet Pump to Tank  
Mounting Bracket



**Pressure Gauge**

# Pro-Source® Composite Fibrewound Tanks



NSF/ANSI 61  
Drinking Water

## Built Tough...for Quality

Every Pro-Source® Composite tank utilizes a durable, FDA approved air cell which is resistant to chlorine and will not promote taste or odor problems associated with iron bacteria that may be present in the water supply.

## Built Tough...for Durability

Each tank is wrapped with more than three miles of overlapping, continuous fiberglass strands, sealed with high-grade epoxy resin, then oven-cured. Tough composite construction means longer lasting tanks that will not rust, corrode, dent or scratch.

## Built Tough...for Easy Installation and Service

Not only is composite construction tougher, it's also more lightweight...as little as half the weight of steel tanks. Installation is faster, easier and can be handled by one person. Repairable with the tank installed.

## ORDERING INFORMATION

Catalog Number	Tank Capacity Gal./Liter	Tank Diameter Inch / cm	Tank Height Inch / cm	Discharge Tapping Inch / cm	Water Yield Per Pump Cycle Pressure Switch Setting		
					20-40 Gal./ Liter	30-50 Gal./ Liter	40-60 Gal./ Liter
PSC-14-4	14.5 / 55	16 / 41	28.2 / 71.6	1 / 2.5	4.9 / 18.7	4.4 / 16.5	3.8 / 14.3
PSC-20-6	19.8 / 75	16 / 41	34.1 / 86.6	1 / 2.5	6.7 / 25.5	5.9 / 22.5	5.1 / 19.5
PSC-30-9	29.5 / 112	16 / 41	46.3 / 117.6	1 / 2.5	10.0 / 38.1	8.9 / 33.5	7.7 / 29.1
PSC-40-12	40.3 / 153	16 / 41	59.0 / 149.9	1 / 2.5	13.7 / 52.0	12.1 / 45.8	10.5 / 39.8
PSC-48-14	47.1 / 178	21 / 53	43.6 / 110.7	1.25 / 3.1	16.0 / 60.5	14.1 / 53.5	12.2 / 46.3
PSC-60-20	60 / 227	24 / 61	44.4 / 112.8	1.25 / 3.1	20.4 / 77.2	18.0 / 68.1	15.6 / 59.0
PSC-80-23	79.6 / 301	21 / 53	65.5 / 166.4	1.25 / 3.1	27.1 / 102.3	23.8 / 90.4	20.7 / 78.3
PSC-85-25	86.7 / 328	24 / 61	57.2 / 145.3	1.25 / 3.1	29.5 / 111.5	26.0 / 98.5	22.5 / 85.3
PSC-119-35	119.7 / 453	24 / 61	75.4 / 191.5	1.25 / 3.1	40.7 / 154	35.9 / 135.9	31.1 / 117.8

Maximum Operating Pressure = 125 PSI, PSC - 80-23 has a maximum operating pressure of 100 PSI.  
Maximum Internal Water Temperature: 120°F (49°C). Maximum Ambient Air Temperature: 120°F (49°C)  
Distance from base to center line of connection is 2-1/4" (5.7 cm)\*. Allow 12" (30.5 cm) for service clearance.  
\*1-3/4" (4.4 cm) for 16" diameter tanks

Certified to ANSI/NSF 61, Drinking Water System Components

# Pro-Source® Composite Fibrewound Tanks

## APPLICATIONS

**Use wherever pressurized tanks are needed in water systems applications.**

## SPECIFICATIONS

**Inner Liner:** One-piece high-density polyethylene

**Outer Shell:** Fiberglass-wound, oven-cured, and epoxy resin sealed

**Exclusive Air Cell:** Heavy gauged PEU, meets Water Quality Association standards

**Base:** Rotatable base with quick connect

**Service Connection:** Stainless steel, 300 grade

## FEATURES

**Durable Composite Construction:** A rugged one-piece molded inner liner of premium high-density polyethylene.

Miles of continuous overlapping fiberglass strands, sealed with oven-cured epoxy, make the outer shell impervious to rust, dents and ultra-violet rays (no paint to scratch and touch up).

**Air Cell:** Seamless, durable PEU air cell is full replaceable and constructed of heavy-gauge engineered polymer. Meets Water Quality Association standards.

**Tank Base:** Rigid molded ABS is the sturdiest composite base on the market. Corrosion- and impact-resistant.

**Replaceable Air Cell:** Generous and accessible air cell opening facilitates easy removal and re-installation of replacement air cell (with the professional contractor in mind). Replaceable on PSC line of Fibrewound.

**Stainless Steel Service Connection:** 300 grade, the professional's choice

## TANK SIZING RULE:

**Size tank for one gallon of drawdown for each gallon per minute at pump capacity.**

**Example:** For a 1 HP, 20 GPM unit pumping 20 gallons per minute on a 30-50 pressure switch setting, the properly sized Pro-Source composite tank is a PSC-80-23, which has a 23.8 gallon drawdown.

# Pro-Source® Composite Fibrewound Tanks

## OPERATING CYCLE

**1. Pro-Source® Composite tank is nearly empty:** air cell is fully expanded

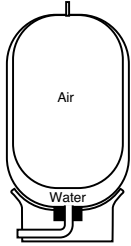

**2. Water is pumped into tank:** air in cell is compressed

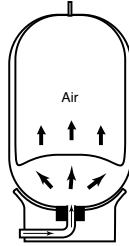

**3. Pump-up cycle is complete:** air is now compressed to "cut off" setting of pressure switch

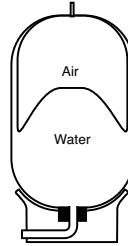

**4. Water is drawn from tank:** pressure in air cell provides water as needed, until tank is empty and cycle repeats

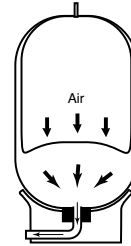

## CHART A

TANK SELECTION CHART

Pump GPM	SYSTEM PRESSURE SWITCH SETTING – PSI					
	20-40		30-50		40-60	
	Runtimes					
	1 Minute	2 Minute	1 Minute	2 Minute	1 Minute	2 Minute
5	PSC-20-6	PSC-30-9	PSC-20-6	PSC-40-12	PSC-20-6	PSC-40-12
7.5	PSC-30-9	PSC-48-14	PSC-30-9	PSC-60-20	PSC-30-9	PSC-60-20
12.5	PSC-40-12	PSC-80-23	PSC-48-14	PSC-85-25	PSC-60-20	PSC-119-35
15	PSC-48-14	PSC-119-35	PSC-60-20	PSC-119-35	PSC-60-20	PSC-119-35
20	PSC-60-20	PSC-119-35	PSC-80-23	PSC-80-23 (2)	PSC-80-23	PSC-80-23 (2)
30	PSC-85-25	PSC-85-25 (2)	PSC-119-35	PSC-119-35 (2)	PSC-119-35	PSC-119-35 (2)
50	PSC-80-23 (2)	PSC-119-35 (3)	PSC-85-25 (2)	PSC-119-35 (3)	PSC-119-35 (2)	PSC-119-35 (3)

**NOTE:** Drawdown will be affected by operating temperature of the system, accuracy of the pressure switch and gauge, the actual precharge pressure, and rate of fill.

## CHART B

DRAWDOWN VOLUME MULTIPLIER\* (APPROXIMATE)

Pump Off Pressure PSI	PUMP START PRESSURE – PSI							
	10	20	30	40	50	60	70	80
20	0.26							
30	0.41	0.22						
40		0.37	0.18					
50		0.46	0.31	0.15				
60			0.40	0.27	0.13			
70			0.47	0.35	0.24	0.12		
80				0.42	0.32	0.21	0.11	
90				0.48	0.38	0.29	0.19	0.10
100					0.44	0.35	0.26	0.17

\*Utilize this chart if proper selection cannot be made using tank selection chart. Drawdown based on Boyle's Law.

Procedure:

1. Identify drawdown multiplier relating to specific application.

2. Insert multiplier (X) into the following formula:  

$$\frac{\text{Pump GPM} \times \text{Min Runtime}}{\text{Multiplier (X)}} = \text{Minimum Tank Capacity Required}$$

3. Refer to "Ordering Information" Table – Max. Capacity Gals.

# Pro-Source® Composite Fibrewound Tanks

## Contact

### FCT Series Contact Tanks



FCT40

FCT80

FCT120



NSF/ANSI 61  
Drinking Water

### Built Tough...for Quality

Professional grade composite construction means longer lasting tanks that will not rust, corrode, dent or scratch.

### Built Tough...for Durability

Each tank is wrapped with more than three miles of overlapping, continuous fiberglass strands, sealed with high-grade epoxy resin, then oven-cured.

### Built Tough... for Easy Installation

Composite construction is lightweight... as little as half the weight of steel tanks. Installation is faster, easier and can be handled by one person.

## APPLICATIONS

### Residential Water Systems

### Industrial, Commercial and Agricultural

## SPECIFICATIONS

**Inner Liner:** One-piece high-density polyethylene

**Outer Shell:** Fiberglass-wound and epoxy resin sealed

**Upper and Lower Flanges:** Reinforced polypropylene

**Base:** One-piece ABS

**Service Connections:** Reinforced polypropylene

## FEATURES

### Durable Composite

**Construction:** A rugged one-piece molded inner liner of premium high-density polyethylene. Miles of continuous overlapping fiberglass strands, sealed with oven-cured epoxy, make the outer shell impervious to rust, dents and ultra-violet rays (no paint to scratch and touch up).

**Tank Base:** Rigid ABS is the sturdiest composite base on the market. Corrosion- and impact-resistant. Base rotates 360° for ease-of-service hook-up.

**Composite Service Connection:** Threaded for ease of installation.

## ORDERING INFORMATION

### FCT SERIES CONTACT TANKS

Catalog Number	Maximum Capacity Gal./Liter	Maximum Operating Pressure PSI/kPa/Bar	Diameter Inch/cm	Overall Height Inch/cm	Height Inlet/Outlet to Floor Inch/cm	Top System Connection	Bottom System Connection	Assembly Weight Lbs./kg
FCT40	40/151	75/500/5.0	16/41	57.25/145	1.5/3.8	1-1/4" Socket	1-1/4" Socket	28/12.7
FCT80	80/303	75/500/5.0	21/53	62.75/159	2/5.1	1-1/4" Socket	1-1/4" Socket	43/19.5
FCT120	120/454	75/500/5.0	24/61	73.25/186	2/5.1	1-1/4" Socket	1-1/4" Socket	63/28.6

Maximum external operating temperature 120°F (49°C).

Maximum internal operating temperature 100°F (38°C).

Minimum operating temperature 40°F (4°C).

Certified to ANSI/NSF 61, Drinking Water System Components.

In order to provide the best products possible, specifications are subject to change.

# Pro-Source® Composite Fibrewound Tanks

## Sideport Contact

### SP Series Sideport Contact Tanks



NSF/ANSI 61  
Drinking Water

#### Built Tough...for Quality

Professional grade composite construction means longer lasting tanks that will not rust, corrode, dent or scratch.

#### Built Tough...for Durability

Each tank is wrapped with more than three miles of overlapping, continuous fiberglass strands, sealed with high-grade epoxy resin, then oven-cured.

#### Built Tough... for Easy Installation

Composite construction is lightweight... as little as half the weight of steel tanks. Installation is faster, easier and can be handled by one person.

### APPLICATIONS

**Residential Water Systems**

**Industrial, Commercial and Agricultural**

### SPECIFICATIONS

**Inner Liner:** One-piece high-density polyethylene

**Outer Shell:** Fiberglass-wound and epoxy resin sealed

**Upper and Lower Flanges:** Reinforced polypropylene

**Base:** One-piece ABS

**Service Connections:** Reinforced polypropylene

### FEATURES

#### Durable Composite

**Construction:** A rugged one-piece molded inner liner of premium high-density polyethylene. Miles of continuous overlapping fiberglass strands, sealed with oven-cured epoxy, make the outer shell impervious to rust, dents and ultra-violet rays (no paint to scratch and touch up).

**Tank Base:** Rigid ABS is the sturdiest composite base on the market. Corrosion- and impact-resistant. Base rotates 360° for ease-of-service hook-up.

**Composite Service Connection:** Threaded for ease of installation.

### ORDERING INFORMATION

#### SP SERIES SIDEPORT CONTACT TANKS

Catalog Number	Maximum Capacity Gal./Liter	Drawdown 30-50 Setting Gallons/Liters	Diameter Inch/cm	Overall Height Inch/cm	Height Inlet/Outlet to Floor Inch/cm	Height Sideport to Floor Inch/cm	Unit Ship Weight Lbs./kg
SP-7	30/114	7/26	16/41	43.75/111	1.5/3.8	14/35.6	26/11.8
SP-9	40/151	9/34	16/41	56.5/144	1.5/3.8	15.5/39.4	35/15.9
SP-9SQ	47/178	9/34	21/53	41.25/105	2/5.1	16.9/42.9	48/21.8
SP-18	80/303	18/67	21/53	62/157	2/5.1	18.3/46.5	67/30.5
SP-26	120/454	26/98	24/61	72.5/184	2/5.1	20.2/51.3	97/44.1

Maximum Operating Pressure = 100 PSI

1-1/4" System connections sidewall. Customer-supplied air control valve. Bottom, dual port 1-1/4" PVC.



**U238-5**  
Air Volume Controls  
(Jet pump type)

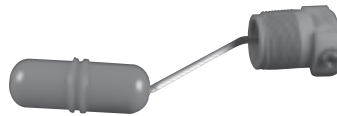

**E238-2**  
Air Volume Control  
(Submersible type)

Certified to ANSI/NSF 61, Drinking Water System Components.

In order to provide the best products possible, specifications are subject to change.

# Pro-Source® Plus Steel Tanks

Premium, heavy-gauge steel tanks

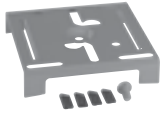

**PKG 198**  
Universal Jet Pump to Tank Bracket  
SOLD SEPERATE



**Stainless Steel Service Connection – “The Professional’s Choice”**  
**Metal Air Valve Assembly – “Field-Serviceable”**  
**125 PSI Maximum Operating Pressure – Four Sizes: PSP50, PSP62, PSP85 and PSP119**

## APPLICATIONS

**Residential Water Systems**  
**Industrial, Commercial and Agricultural**

## SPECIFICATIONS

**Shell:** Heavy-gauge steel

**Base:** High-impact composite, ABS

**Finish:** Electrostatically applied, baked-on polyester paint

**Water Cell:** One-piece seamless PVC, made from FDA listed material

**Flange:** 304SS

**Service Connection:** NPT threads, integral to flange

**Air Valve:** Nickel-plated brass, threaded for ease of service

In order to provide the best products possible, specifications are subject to change.

## ORDERING INFORMATION

Catalog Number	Maximum Capacity Gal./Liter	Diameter* Inch/cm	Height* Inch/cm	Precharge PSI/kPa	Connection Size Female	Drawdown In Gallons/Liters			Weight Lbs./kg	Maximum Operating PSI
						20-40	30-50	40-60		
<b>VERTICAL MODELS</b>										
PSP19S-T02	19/72	20/51	21.5/55	40/276	1" NPT	6.9/26.1	5.8/21.9	5.0/18.9	49/22.2	100
PSP19T-T02	19/72	16/40.6	27.8/71	40/276	1" NPT	6.9/26.1	5.8/21.9	5.0/18.9	44/20.0	100
PSP32-T03	32/121	16/40.6	43/109	40/276	1" NPT	11.6/43.9	9.8/37.1	8.5/32.2	60/27.2	100
PSP35-T05	35/133	20/51	33/84	40/276	1" NPT	12.7/48.1	10.7/40.5	9.3/35.2	70/31.8	100
PSP50-T50	50/189	24/61	33.2/84	40/276	1-1/4" NPT	18.3/69.3	15.5/58.7	13.4/50.7	88/39.9	125
PSP62-T51	62/235	24/61	40.1/102	40/276	1-1/4" NPT	21.4/81.0	18.3/69.3	16.0/60.6	116/52.6	125
PSP85-T52	85/322	24/61	51.5/131	40/276	1-1/4" NPT	30/113.6	26/98.4	22.0/83.3	128/58.1	125
PSP119-TR50	119/450	24/61	68.6/174	40/276	1-1/4" NPT	41.3/156.3	35.4/134.0	31.0/117.3	140/63.5	125

\*Subject to change without notice.

Maximum Liquid Temperature: 120°F (49°C)

Maximum External (Ambient) Temperature: 125°F (52°C)

# Pro-Source® Plus Steel Tanks

Premium, heavy-gauge steel tanks

## FEATURES

**Service Connection:** 304 stainless steel.

**Air Valve:** Nickel-plated brass.

**Maximum Operating Pressure:**

100 PSI on 16" and 20" tanks;

125 PSI on 24" tanks.

**Heavy-Gauge Metal Construction:**

Sturdy "welded wrapper and head design."  
Built to last.

**Polyester Paint Finish:** Electrostatically powder-painted, then oven-baked for a smooth high-gloss, appliance-quality finish. Resists corrosion.

**Elongated, Seamless Water Cell:**

– Controlled 2-dimensional cell expansion.

– Rugged, seamless "water cell" prevents the most common cause of pump failure – "waterlogging."

– Water never touches the steel tank material.

– Translucent bag material facilitates manufacturing quality control inspection.

**NEW Stainless Service Connection:**

– Corrosion-resistant.

– Stainless steel – the professional's choice.

**Integral Standpipe:** Promotes complete flushing of the water entering/exiting the tank.

**Nitrogen-Rich Precharge:** Decreases air permeation three to four times over straight air precharge.

**40 PSI Precharge:** Ready for use with 40/60 pressure range systems. Enables installer to reduce pressure depending on pressure switch setting.

**Sturdy Base:** Tested-tough composite construction.

## TANK SIZING RULE:

**Size tank for one gallon of drawdown for each gallon per minute at pump capacity.**

Example: For a 1 HP, 20 GPM unit pumping 20 gallons per minute on a 30-50 pressure switch setting, the properly sized Pro-Source® PLUS tank is a PSP85-T52 which has a 26 gallon drawdown.

### CHART A: TANK SELECTION CHART

Pump GPM	SYSTEM PRESSURE SWITCH SETTING – PSI					
	20-40		30-50		40-60	
	Runtimes					
	1 Minute	2 Minute	1 Minute	2 Minute	1 Minute	2 Minute
5	PSP19T	PSP32	PSP19T	PSP35	PSP19T	PSP50
7.5	PSP32	PSP50	PSP32	PSP50	PSP32	PSP62
10	PSP32	PSP62	PSP35	PSP85	PSP50	PSP85
12.5	PSP35	PSP85	PSP50	PSP85	PSP50	PSP119
15	PSP50	PSP85	PSP50	PSP119	PSP62	PSP119
20	PSP62	PSP119	PSP85	PSP85 (2)	PSP85	PSP85 (2)
30	PSP85	PSP85 (2)	PSP119	PSP119 (2)	PSP119	PSP119 (2)
50	PSP62 + PSP85	PSP119 (2) + PSP62	PSP85 (2)	PSP119 (3)	PSP119 (2)	PSP119 (4)

Note: Drawdown will be affected by operating temperature of the system, accuracy of the pressure switch and gauge, the actual precharge pressure, and rate of fill. Pumps installed with a Pro-Source® PLUS tank require a relief valve equal to the tank's maximum operating pressure. Relief valve must be capable of relieving entire flow of pump at relief pressure.

### CHART B: DRAWDOWN VOLUME MULTIPLIER\* (APPROX.)

Pump Off Pressure PSI	PUMP START PRESSURE – PSI							
	10	20	30	40	50	60	70	80
20	0.26							
30	0.41	0.22						
40		0.37	0.18					
50		0.46	0.31	0.15				
60			0.40	0.27	0.13			
70			0.47	0.35	0.24	0.12		
80				0.42	0.32	0.21	0.11	
90					0.48	0.38	0.29	0.19
100						0.44	0.35	0.26

\*Utilize this chart if proper selection cannot be made using Chart A. Drawdown based on Boyle's Law.

**PROCEDURE:** 1. Identify drawdown multiplier relating to specific application.  
2. Insert multiplier (X) into the following formula:

$$\frac{\text{Pump GPM} \times \text{Min Runtime}}{\text{Multiplier (X)}} = \text{Minimum Tank Capacity Required}$$

**EXAMPLE:** An example of a 20 GPM pump with a minimum runtime of 1 minute, installed on a 50-70 PSIG system pressure range:  

$$\frac{20 \text{ GPM} \times 1 \text{ minute}}{.24 \text{ (factor) from Chart B}} = 83.3 \text{ minimum U.S. gal. tank capacity required}$$

Referring to "Ordering Information" chart, the model PSP85-T52 has the closest U.S. gallon capacity that is greater or equal to the minimum volume requirement of 83.3 U.S. gallons.

# Pro-Source® Plus Steel Tanks

Premium, heavy-gauge

## OPERATING CYCLE

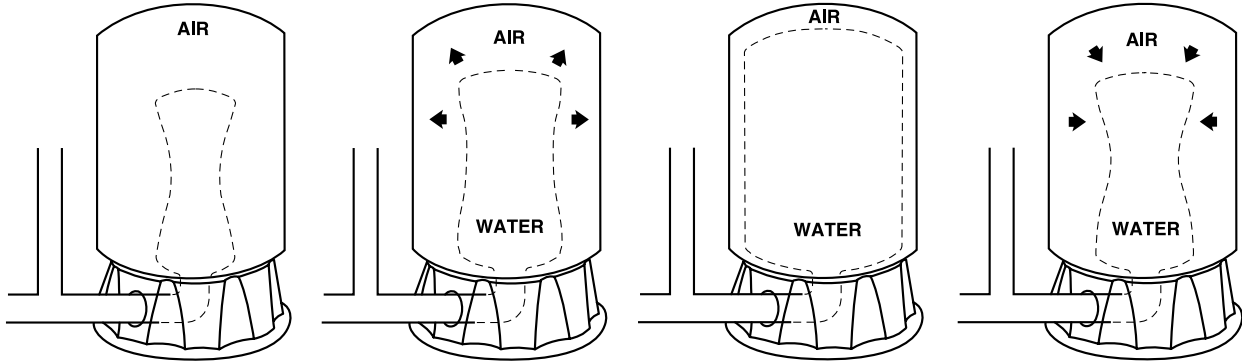

**1. Separator is completely empty:**  
A new cycle is ready to begin. Simple, positive action produces maximum drawdown on every cycle.

**2. Water begins to enter the tank:** Air is compressed around the water separator as it fills with water.

**3. Pump-up cycle completed:** Air is now compressed to the cut-off setting of pressure switch.

**4. Water is being drawn from the tank:** Compressed air in the tank forces water out of the separator.

## ACCESSORIES

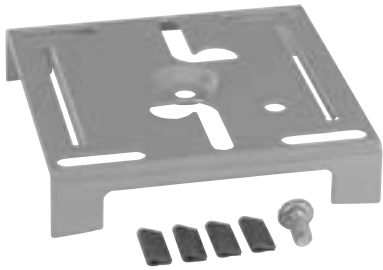

**PKG 198**  
Universal Jet Pump  
to Tank Bracket



**PKG 111,**  
**PKG 112 or**  
**PKG 207**  
Jet Pump-to-Tank  
Mounting Pkg.

## ORDERING INFORMATION

PKG 198	Jet Pump Mounting Bracket
PKG 111	Pump-to-Tank Fitting Package for composite jet pumps
PKG 112	Pump-to-Tank Fitting Package for cast iron series jet pumps with composite fittings
PKG 207	Pump-to-Tank Fitting Package for cast iron series jet pumps with galvanized fittings

## OUTLINE DIMENSIONS

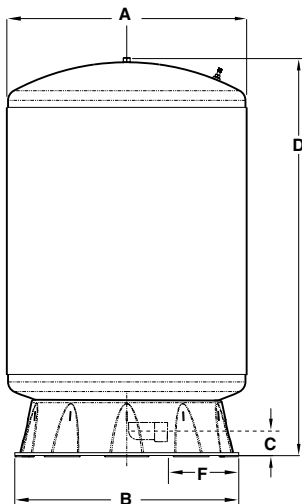

Catalog Number	Discharge NPT	A	B	C	D	E
PSP19S-T02	1"	20.1	15.5	2.0	21.5	2.3
PSP19T-T02	1"	16.1	15.5	2.0	27.8	3.9
PSP32-T02	1"	16.1	15.5	2.0	43.0	2.3
PSP35-T05	1"	20.1	15.5	2.0	33.0	2.3
PSP50-T50	1-1/4"	24.1	22.7	2.5	33.2	5.5
PSP62-T51	1-1/4"	24.1	22.7	2.5	40.1	5.5
PSP85-T52	1-1/4"	24.1	22.7	2.5	51.5	5.5
PSP119-TR50	1-1/4"	24.1	22.7	2.5	68.6	5.5

Dimensions (in inches) are for estimating purposes only.

# Pro-Source® Steel Tanks

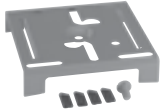

**PKG 198**  
Universal Jet Pump to Tank Bracket  
SOLD SEPERATE



## APPLICATIONS

Use wherever pressurized tanks are needed in water systems applications.

## SPECIFICATIONS

**Shell:** Heavy-gauge steel

**Base:** High-impact composite, ABS

**Finish:** Electrostatically applied, baked-on polyester paint

**Water Cell:** One-piece seamless PVC, made from FDA listed material

**Flange:** Reinforced polypropylene

**Service Connection:** Reinforced polypropylene integral to flange

**Air Valve:** Rubber stem/brass body Schrader valve assembly

**UV Valve Cover:** High-density polyethylene

## ORDERING INFORMATION

Catalog Number	Maximum Capacity Gal/Liter	Diameter* Inch/cm	Height Inch/cm	Length Inch/cm	Precharge PSI/kPa	Connection Size Female	Drawdown in Gallons/Liter			Weight lbs/kg
							20-40	30-50	40-60	
<b>VERTICAL MODELS</b>										
PS6-S02	6.0/22.7	12/30.5	16.1/40.9	-	40/276	3/4" NPT	2.2/8.3	1.8/6.8	1.6/6.0	18/8.2
PS19S-T02	19/72	20/51	21/53.3	-	40/276	1" NPT	6.9/26.1	5.8/21.9	5.0/18.9	45/20.4
PS19T-T02	19/72	16/40.6	27.5/70	-	40/276	1" NPT	6.9/26.1	5.8/21.9	5.0/18.9	40/18.1
PS32-T03	32/122	20/51	43/109	-	40/276	1" NPT	11.6/43.9	9.8/37.1	8.5/32.2	56/25.4
PS35-T05	35/133	16/40.6	33/84	-	40/276	1" NPT	12.7/48.1	10.7/40.5	9.3/35.2	66/29.9
PS50-T50	50/189	20/51	32.5/83	-	40/276	1-1/4" NPT	18.3/69.3	15.5/58.7	13.4/50.7	84/38.1
PS62-T51	62/235	24/61	39.5/100	-	40/276	1-1/4" NPT	21.4/81.0	18.3/69.3	16.0/60.6	112/50.8
PS85-T52	85/322	24/61	51/130	-	40/276	1-1/4" NPT	30/113.6	26/98.4	22/83.3	124/56.2
PS119-TR50	119/450	24/61	68/173	-	40/276	1-1/4" NPT	41.3/156.3	35.4/134.0	31.0/117.3	140/63.5
<b>IN-LINE VERTICAL MODELS</b>										
PS2-S01	2.0/7.6	8.4/21.3	12.6/32.0	-	20/137.8	3/4" NPTM	0.7/2.65	0.6/2.2	NA	12.6/5.7
PS5-S02	5.0/18.9	10.6/26.9	16.2/41.1	-	30/206.8	3/4" NPTM	2.2/8.3	1.8/6.8	1.8/6.8	16.2/7.3
<b>HORIZONTAL MODELS</b>										
PS6H-S05	6.0/22.7	12/30.5	13.8/35.0	16/40.6	40/276	3/4" NPT	2.2/8.3	1.8/6.8	1.6/6.0	22/10
PS19H-S00	19/72	16/40.6	17.5/44.5	28/71.1	40/276	1" NPT	6.9/26.1	5.8/21.9	5.0/18.9	40/18

\*Subject to change without notice.

Maximum Operating Pressure = 100 PSI

Maximum Liquid Temperature: 120°F (49°C) Maximum External (Ambient) Temperature: 125°F (52°C)

# Pro-Source® Steel Tanks

## FEATURES

### Heavy-Gauge Metal Construction:

Sturdy “welded wrapper and head design.”  
Built to last.

**Polyester Paint Finish:** Electrostatically powder-painted, then oven-baked for a smooth high-gloss, appliance-quality finish. Resists corrosion.

### Elongated, Seamless Water Cell:

Controlled 2-dimensional cell expansion.

Rugged, seamless “water cell” prevents the most common cause of pump failure – “waterlogging.”

Water never touches the steel tank material.

Translucent bag material facilitates manufacturing quality control inspection.

### Composite Sealing Flange:

- Corrosion-resistant.
- Integral O-ring groove better traps the water cell’s sealing ring.
- Reinforcing ribs strengthen and maintain a flat smooth sealing surface.

**Integral Standpipe:** Keeps the water cell standing erect, promoting complete flushing of the water entering/exiting the tank.

**Nitrogen-Rich Precharge:** Decreases air permeation three to four times over straight air precharge.

**40 PSI Precharge:** Ready for use with 40/60 pressure range systems. Enables installer to reduce pressure depending on pressure switch setting.

**Sturdy Base:** Tested-tough composite construction.

## TANK SIZING RULE:

### Size tank for one gallon of drawdown for each gallon per minute at pump capacity.

Example: For a 1 HP, 20 GPM unit pumping 20 gallons per minute on a 30-50 pressure switch setting, the properly sized Pro-Source® tank is a PS85-T52 which has a 26 gallon drawdown.

**CHART A: TANK SELECTION CHART**

Pump GPM	SYSTEM PRESSURE SWITCH SETTING – PSI					
	20-40		30-50		40-60	
	Runtimes					
	1 Minute	2 Minute	1 Minute	2 Minute	1 Minute	2 Minute
5	PS19T	PS32	PS19T	PS35	PS19T	PS50
7.5	PS32	PS50	PS32	PS50	PS32	PS62
10	PS32	PS62	PS35	PS85	PS50	PS85
12.5	PS35	PS85	PS50	PS85	PS50	PS119
15	PS50	PS85	PS50	PS119	PS62	PS119
20	PS62	PS119	PS85	PS85 (2)	PS85	PS85 (2)
30	PS85	PS85 (2)	PS119	PS119 + PS85	PS119	PS119 (2)
30	-	-	PS119	PS119 + PS85	PS119	PS119 (2)
50	PS62 + PS85	PS85 (3)	PS85 (2)	PS119 (3)	PS85 + PS119	PS119 (3) + PS50

Note: Drawdown will be affected by operating temperature of the system, accuracy of the pressure switch and gauge, the actual precharge pressure, and rate of fill. Pumps installed with a Pro-Source® tank require a 100 PSI relief valve. Relief valve must be capable of relieving entire flow of pump at relief pressure.

**CHART B: DRAWDOWN VOLUME MULTIPLIER\* (APPROX.)**

Pump Off Pressure PSI	PUMP START PRESSURE – PSI							
	10	20	30	40	50	60	70	80
20	0.26							
30	0.41	0.22						
40		0.37	0.18					
50		0.46	0.31	0.15				
60			0.40	0.27	0.13			
70			0.47	0.35	0.24	0.12		
80				0.42	0.32	0.21	0.11	
90				0.48	0.38	0.29	0.19	0.10
100					0.44	0.35	0.26	0.17

\*Utilize this chart if proper selection cannot be made using Chart A. Drawdown based on Boyle’s Law.

- PROCEDURE:**
1. Identify drawdown multiplier relating to specific application.
  2. Insert multiplier (X) into the following formula:

$$\frac{\text{Pump GPM} \times \text{Min Runtime}}{\text{Multiplier (X)}} = \text{Minimum Tank Capacity Required}$$

**EXAMPLE:** An example of a 20 GPM pump with a minimum runtime of 1 minute, installed on a 50-70 PSIG system pressure range:

$$\frac{20 \text{ GPM} \times 1 \text{ minute}}{.24 \text{ (factor) from Chart B}} = 83.3 \text{ minimum U.S. gal. tank capacity required}$$

Referring to “Ordering Information” chart, the model PS85-T52 has the closest U.S. gallon capacity that is greater or equal to the minimum volume requirement of 83.3 U.S. gallons.

# Pro-Source® Steel Tanks

## OPERATING CYCLE

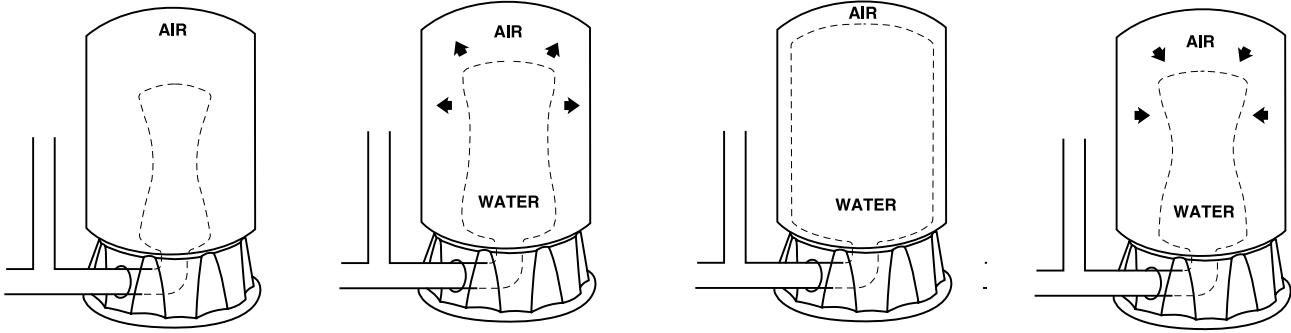

- 1. Separator is completely empty:** A new cycle is ready to begin. Simple, positive action produces maximum drawdown on every cycle.
- 2. Water begins to enter the tank:** Air is compressed around the water separator as it fills with water.
- 3. Pump-up cycle completed:** Air is now compressed to the cut-off setting of pressure switch.
- 4. Water is being drawn from the tank:** Compressed air in the tank forces water out of the separator.

## ACCESSORIES

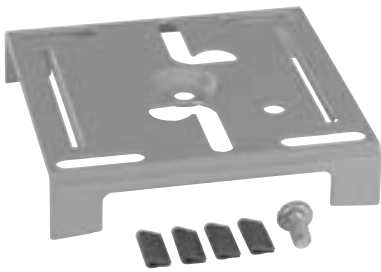

**PKG 198**  
Universal Jet Pump  
to Tank Bracket



**PKG 111,**  
**PKG 112 or**  
**PKG 207**  
Jet Pump-to-Tank  
Mounting Pkg.

## ORDERING INFORMATION

PKG 198	Jet Pump Mounting Bracket
PKG 111	Pump-to-Tank Fitting Package for composite jet pumps
PKG 112	Pump-to-Tank Fitting Package for cast iron series jet pumps with composite fittings
PKG 207	Pump-to-Tank Fitting Package for cast iron series jet pumps with galvanized fittings

## MULTIPLE TANK INSTALLATIONS

Pro-Source® tanks can be connected together to increase the supply of usable water (drawdown). Two tanks of the same size will double the supply and three tanks will triple the supply. See Figures No. 1 and 2 for the typical installations of this kind.

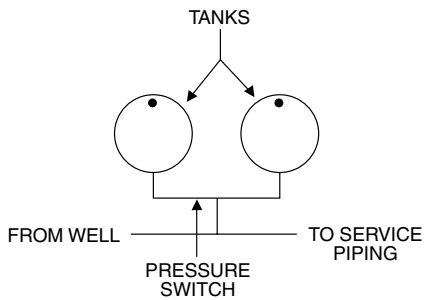

Figure 1

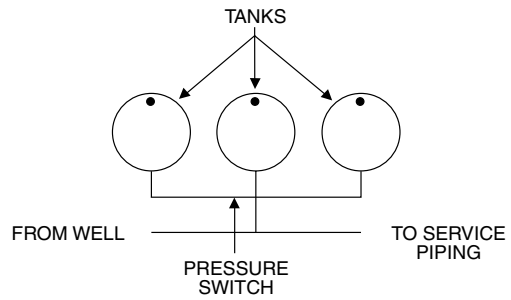
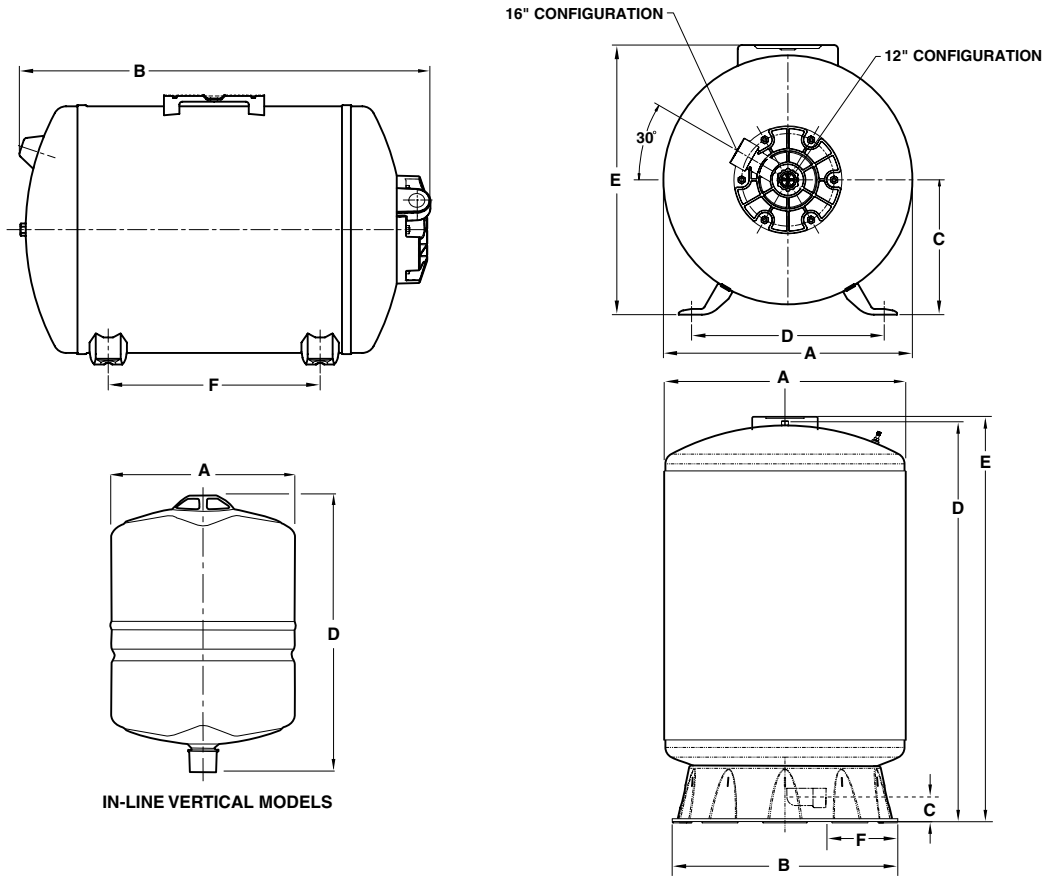

Figure 2

# Pro-Source® Steel Tanks

## OUTLINE DIMENSIONS



Catalog Number	Discharge NPT	A	B	C	D	E	F
<b>VERTICAL MODELS</b>							
PS6-S02	3/4"	12.0	-	-	16.1	-	-
PS19T-T02	1"	16.1	15.5	2.0	27.8	-	3.9
PS32-T03	1"	16.1	15.5	2.0	43.0	-	2.3
PS19S-T02	1"	20.1	15.5	2.0	-	21.5	2.3
PS35-T05	1"	20.1	15.5	2.0	33.0	-	2.3
PS50-T50	1-1/4"	24.1	22.7	2.5	33.2	-	5.5
PS62-T51	1-1/4"	24.1	22.7	2.5	40.1	-	5.5
PS85-T52	1-1/4"	24.1	22.7	2.5	51.5	-	5.5
PS119-TR50	1-1/4"	24.1	22.7	2.5	68.6	-	5.5
<b>IN-LINE VERTICAL MODELS</b>							
PS2-S01	3/4"	18.4	-	-	12.6	-	-
PS5-S02	3/4"	10.6	-	-	16.2	-	-
<b>HORIZONTAL MODELS</b>							
PS6H	3/4"	12.1	16.9	6.9	10.0	13.3	6.1
PS19H	1"	16.2	26.6	8.7	12.5	17.5	13.8

Dimensions (in inches) are for estimating purposes only.

# Pro-Source® Air-Over-Water Tanks

Steel, epoxy-lined



The Pro-Source® Epoxy-Lined Tank is an excellent corrosion-resistant tank available in a variety of sizes for use in water systems applications, as a retention tank or holding tank. This tank utilizes an electrostatic paint process, resulting in superior rust protection.

## APPLICATIONS

For use as a standard water tank, retention tank or holding tank.

## SPECIFICATIONS

**Shell:** Heavy-gauge steel

**Skirt:** Heavy-gauge steel

**Interior Coating:** Epoxy

**Fittings:** Machined steel

**Finish:** Baked-on polyester paint

## FEATURES

**Quality Construction:** The precision press fit head and wrapper minimize the possibility of large gaps between components. This manufacturing process reduces the possibility of corrosion and seam leaks.

**Heavy-Gauge Steel:** Sturdy construction is emphasized, with heavier gauge steel than most tanks. This minimizes the possibility of dents from mishandling, and rust-through.

**Uniform Epoxy Coating:** The insides of the tanks are electrostatically powder-coated and then are oven-baked to ensure proper adhesion and consistent coverage. This paint process offers superior corrosion resistance over traditional wet paints.

**Appliance-Like Exterior Finish:** A polyester paint is also electrostatically adhered to the outer surface and then baked on for a high-gloss appearance.

**Flush Mount Fittings:** Designed to solve one of the toughest corrosion problems, these fittings eliminate flanges and sharp angles that make paint adherence difficult.

**Standard Top Mount Fitting:** Facilitates use as a retention tank, or for hard-to-fit areas. This fitting can also be used for an optional jet mount package.

**Sturdy Base:** Bases for horizontal models are constructed of heavy-gauge steel, with slots for ventilation to avoid condensation problems.

## ORDERING INFORMATION

Catalog Number	Capacity U.S. Gal.	Style	Tank Diameter	Tank Height	Tank Length	Approx. Weight Lbs.	Maximum Operating Pressure (PSI)
AW30H	30	Horizontal	16"	17-1/2"	36-1/2"	55	75
AW42	42	Vertical	20"	36-5/8"	N/A	67	75
AW42T	42	Vertical	16"	53-1/2"	N/A	65	75
AW85	85	Vertical	24"	51"	N/A	94	75
AW120	120	Vertical	24"	68"	N/A	120	75

Max liquid temperature = 120 deg F

Max Operating Pressure = 75 PSI

# Pro-Source® Air-Over-Water Tanks

Steel, epoxy-lined

## VERTICAL OUTLINE DIMENSIONS

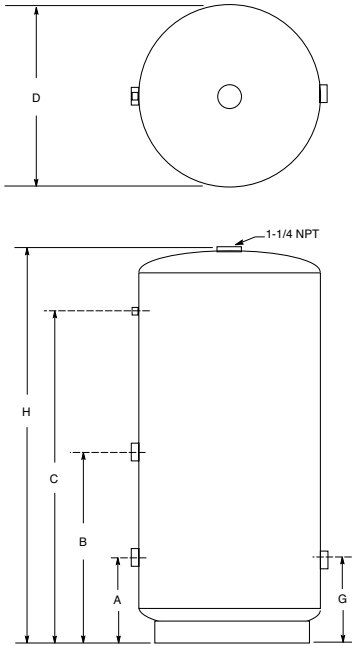

Dimensions (in inches) are for estimating purposes only.

## HORIZONTAL OUTLINE DIMENSIONS

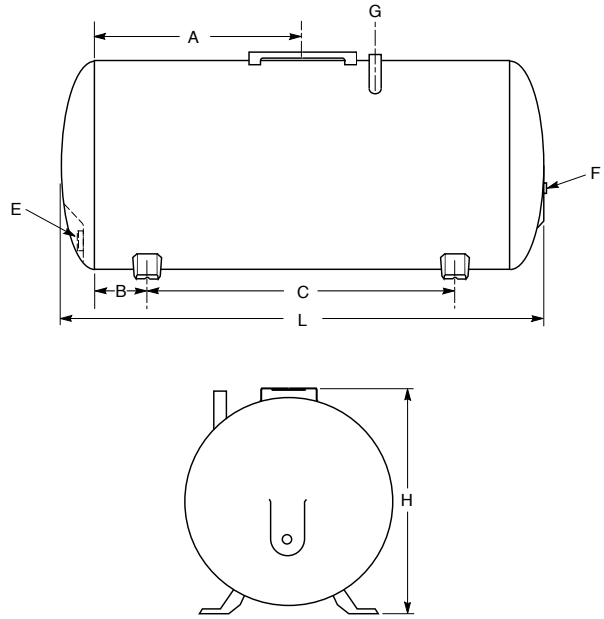

Dimensions (in inches) are for estimating purposes only.

## DIMENSIONAL DATA

### VERTICAL EPOXY-LINED TANKS

Catalog Number	Gallons	Dimensions in Inches									
		D Dia.	H Ht.	A Dist.	A Size	B Dist.	B Size	C Dist.	C Size	G Dist.	G Size
AW42	42	20	36-5/8	8-1/2	1-1/4	19-1/2	1-1/4	27-3/4	1/4	8-1/2	1-1/4
AW42T	42	16	53-1/2	8	1-1/4	28	1-1/4	45	1/4	8	1-1/4
AW85	85	24	51	12	1-1/4	26-1/8	1-1/4	40-7/8	1/4	9-1/2	1-1/4
AW120	120	24	68	12	1-1/4	35	1-1/4	58-1/8	1/4	9-1/2	1-1/4

### HORIZONTAL EPOXY-LINED TANKS

Catalog Number	Gallons	Dimensions in Inches						Outlet Size		
		Dia.	Length	Ht.	A	B	C	E	F	G
AW30H	30	16	36-1/2	17-1/2	13-3/4	4-3/4	22	3/4	1/4	3/4

Horizontal tanks include pump mounting bracket as standard.

Note: All pumps installed with a Pro-Source® tank require a 75 PSI relief valve. Relief valve must be capable of relieving entire pump flow at relief pressure.

## TANK PERFORMANCE

Catalog Number	Capacity U.S. Gal.	Drawdown in Gallons		
		20-40	30-50	40-60
AW30H	30	5.2	4.4	3.9
AW42	42	6.7	5.8	5.0
AW42T	42	6.9	5.9	5.2
AW85	85	14.3	12.3	10.7
AW120	120	19.9	17.1	14.9



**U238-5**  
Air Volume Controls  
(Jet pump type)

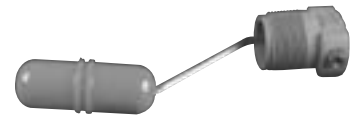

**E238-2**  
Air Volume Control  
(Submersible type)

# PRO-Storm™ DSS Series

Multi-stage



The Pro-Storm™ multi-stage series of sprinkler pumps delivers high-performance without priming problems and delays.

The Pro-Storm multi-stage series is designed for minimal electrical consumption and quiet operation from the professional-grade motor. The new Pro-Storm multi-stage series offers first-in-class priming capabilities of up to 15 foot lifts!

## APPLICATIONS

Residential and commercial turf irrigation  
 Residential water systems  
 Shower and washing systems  
 Water transfer  
 Heating and air conditioning systems  
 Water features and fountains

## SPECIFICATIONS

### Motor Bracket and Integral Pump Base:

Close-grained cast iron, 1-1/2" NPT inlet connection, stable heavy-duty design for rigid pipe and solid base mountings

**Discharge:** Close-grained cast iron, 1-1/4" NPT discharge connection, with easy-access drain port for end of season draining and winterization

**Impellers and Diffusers:** Noryl® precision-molded extra-smooth ports to maximize efficiency and performance

**Outer Shell:** Polished 304 stainless steel

**Shaft:** 303 stainless steel

**Priming Valve:** Special brass priming valve for trouble-free operation during the initial pump priming

**Mechanical Seal:** High-pressure seal, carbon-ceramic seal faces, Buna-N elastomers

**Heavy-Duty Motor:** 2 HP, single-phase, 3450 RPM, 230-volt, high-service factor, capacitor-start/capacitor-run, open drip-proof motor, rated for continuous-duty operation. 230/460 TEFC available

**Maximum Inlet Pressure:** 20 PSI

**Maximum Discharge Pressure:** 130 PSI

**Maximum Operating Temperature:** 120°F (49°C)

**Maximum Suction Lift:** 15 feet

**Number of Stages:** 3 or 4

## ORDERING INFORMATION

Catalog Number	Stages	HP	Pipe Tapping Sizes		Motor Voltage	Approx. Wt. Lbs.
			Suction	Discharge		
DSS4HG	4	2	1-1/2" NPT	1-1/4" NPT	230 1ø	95
DSS4HG3T	4	2	1-1/2" NPT	1-1/4" NPT	230/460 TEFC	95
DSS3HG	3	2	1-1/2" NPT	1-1/4" NPT	230 1ø	95
DSS3HG3T	3	2	1-1/2" NPT	1-1/4" NPT	230/460 TEFC	95

# PRO-Storm™ DSS Series

Multi-stage

## PUMP PERFORMANCE

NOMINAL RPM: 3450, BASED ON FRESH WATER @ 68°F, MAXIMUM WORKING PRESSURE: 175 PSI

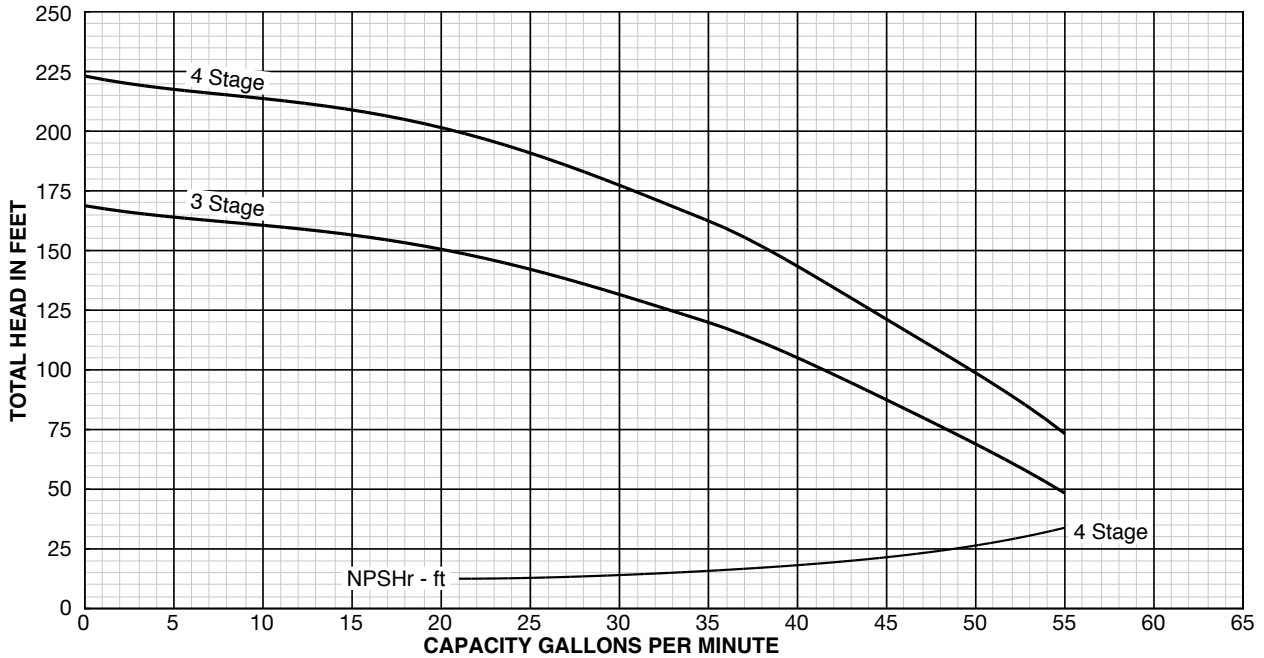

## OUTLINE DIMENSIONS

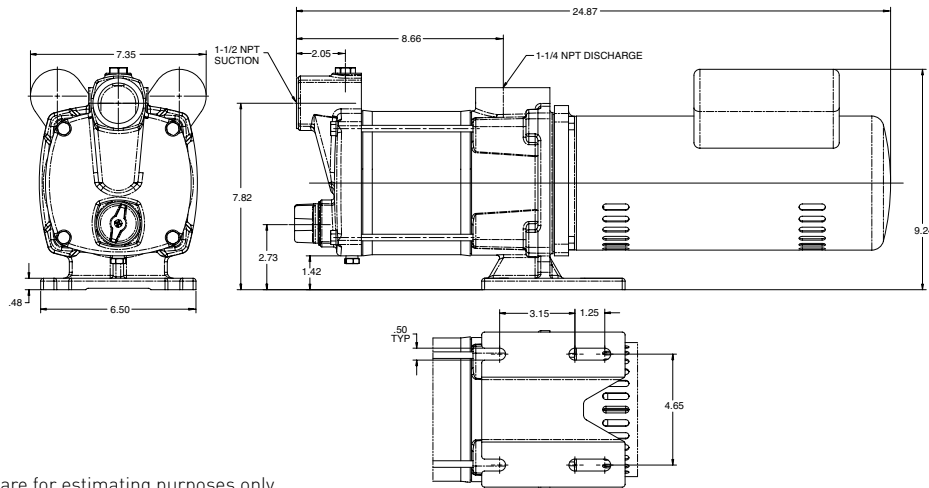

Dimensions (in inches) are for estimating purposes only.

# DS2 Series

Self-priming centrifugal

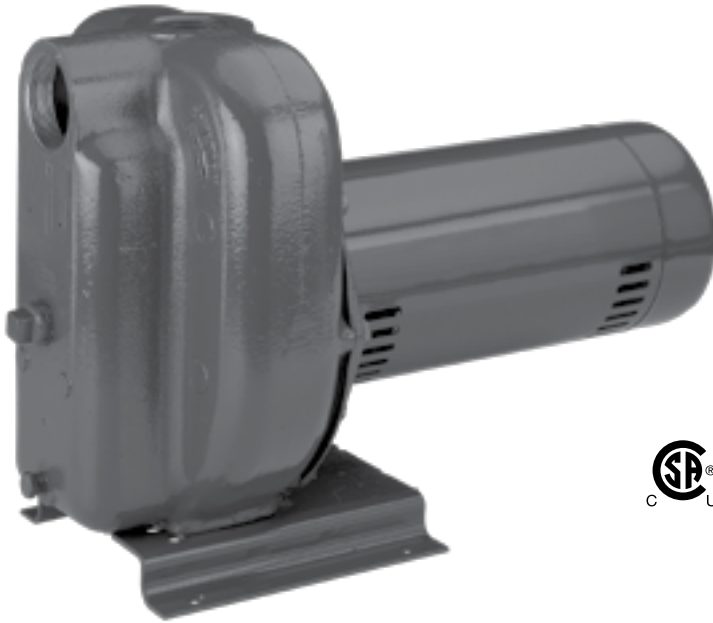

Fast-priming DS2 Series pumps in 1 through 2-1/2 HP models, with a low-friction Lexan® or Noryl® impeller. These high head pumps feature leakproof mechanical seals, easy service design, heavy-duty motors and rugged construction. Self-priming after initial filling with water.

## APPLICATIONS

**Lawn sprinkling:** Pumps can be safely operated by timer or other automatic device

**Contractors:** For dewatering excavation, jetting, water transfer and supply

**Agriculture:** Seed bed and plot irrigation, stock watering, fire protection

**Industrial:** Sump drainage, fire protection, marine pumping, liquid transfer and supply operations

## SPECIFICATIONS

**Body and Base:** Close-grained cast iron

**Impeller:** Lexan® or Noryl®

**Diffuser:** Polypropylene

**Shaft:** Stainless Steel

## FEATURES

**Rugged Construction:** Heavy-duty motors, easy service design

**Drain Port:** Provided for easy winterizing

**High Head Models:** Delivers up to 145' of head with capacities to 95 GPM

**Easy Serviceability:** Normal wearing parts are easily accessible for service and replacement, without disturbing piping or mounting

**Heavy-Duty Motors:** Designed for continuous operation. Capacitor start, will not cause electrical interference with TV or other appliances. Nationally known motors have ball bearing, stainless steel shaft. For single and three-phase operation, 3450 RPM.

## ORDERING INFORMATION

### HIGH HEAD

Catalog Number	HP	Pump/Motor Unit		Motor Voltage	Phase	Approx. Wt. Lbs.
		Suction	Discharge			
DS2HE	1	2"	1-1/2"	115/230	1	73
DS2HE3	1	2"	1-1/2"	208/230/460	3	73
DS2HF	1-1/2	2"	1-1/2"	115/230	1	79
DS2HF3	1-1/2	2"	1-1/2"	208/230/460	3	79
DS2HG	2	2"	2"	230	1	91
DS2HG3	2	2"	2"	208/230/460	3	91
DS2HHG	2-1/2	2"	2"	230	1	93
DS2HHG3	2-1/2	2"	2"	208/230/460	3	93

Pentair trademarks and logos are owned by Pentair plc or its affiliates. All other third party registered and unregistered trademarks and logos are the property of their respective owners.

# DS2 Series

Self-priming centrifugal

## PUMP PERFORMANCE

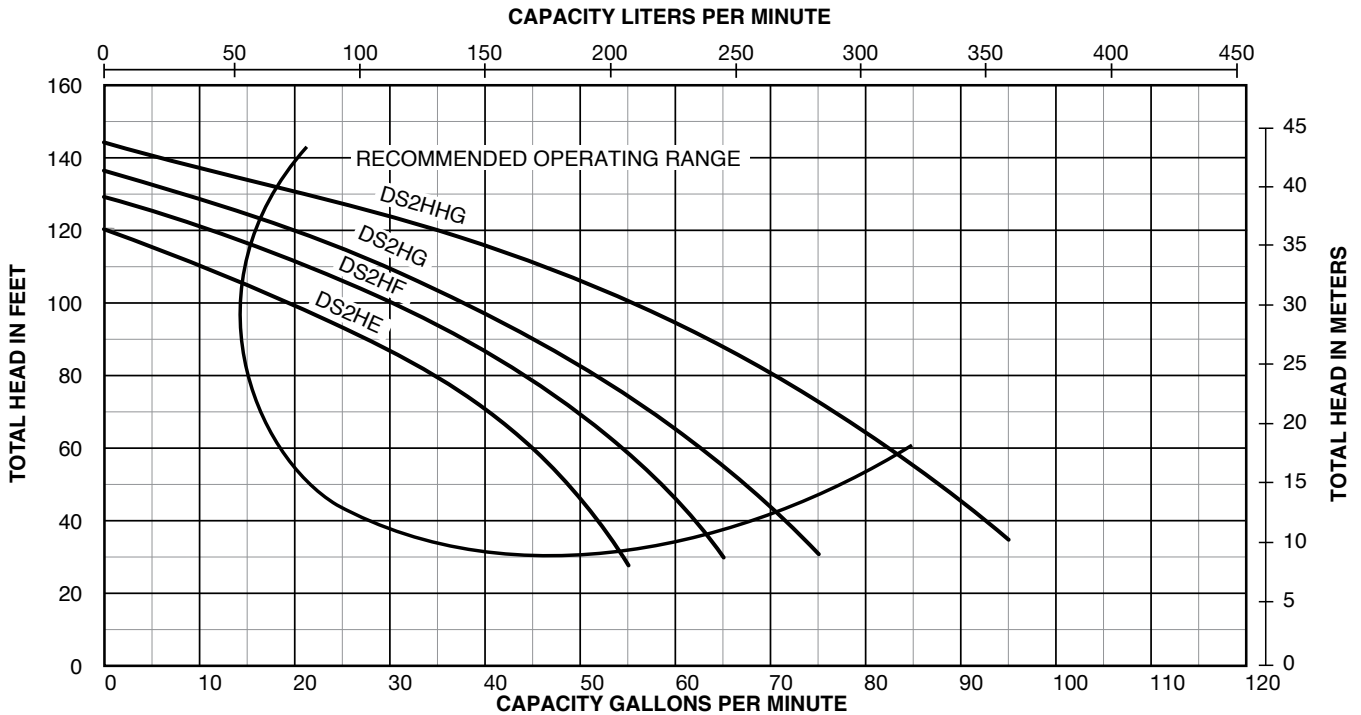

### PUMP PERFORMANCE (Capacity in gallons per minute)

Catalog Number	HP	Discharge Pressure		Suction Lift in Feet				
		PSI	Feet Head	5'	10'	15'	20'	25'
DS2HE	1	20	46.2	46	43	41	38	35
		30	69.3	35	32	29	25	21
		40	92.4	19	15	10	-	-
DS2HF	1-1/2	20	46.2	55	53	51	49	46
		30	69.3	45	42	39	36	32
		40	92.4	31	27	22	18	12
DS2HG	2	20	46.2	64	62	59	57	51
		30	69.3	53	50	47	44	38
		40	92.4	38	35	31	26	20
		50	115.5	19	13	-	-	-
DS2HHG	2-1/2	20	46.2	76	70	65	59	46
		30	69.3	63	57	51	42	23
		40	92.4	48	38	23	-	-
		50	115.5	23	10	-	-	-

Tested and rated in accordance with Water Systems Council Standards.

NOTE: Pumps installed with a Pro-Source® tank require a 100 PSI relief valve. Pumps installed with a conventional tank require a 75 PSI relief valve. Relief valve must be capable of relieving entire flow of pump at relief pressure.

Specifications are subject to change without notice.

# DS2 Series

Self-priming centrifugal

## OUTLINE DIMENSIONS

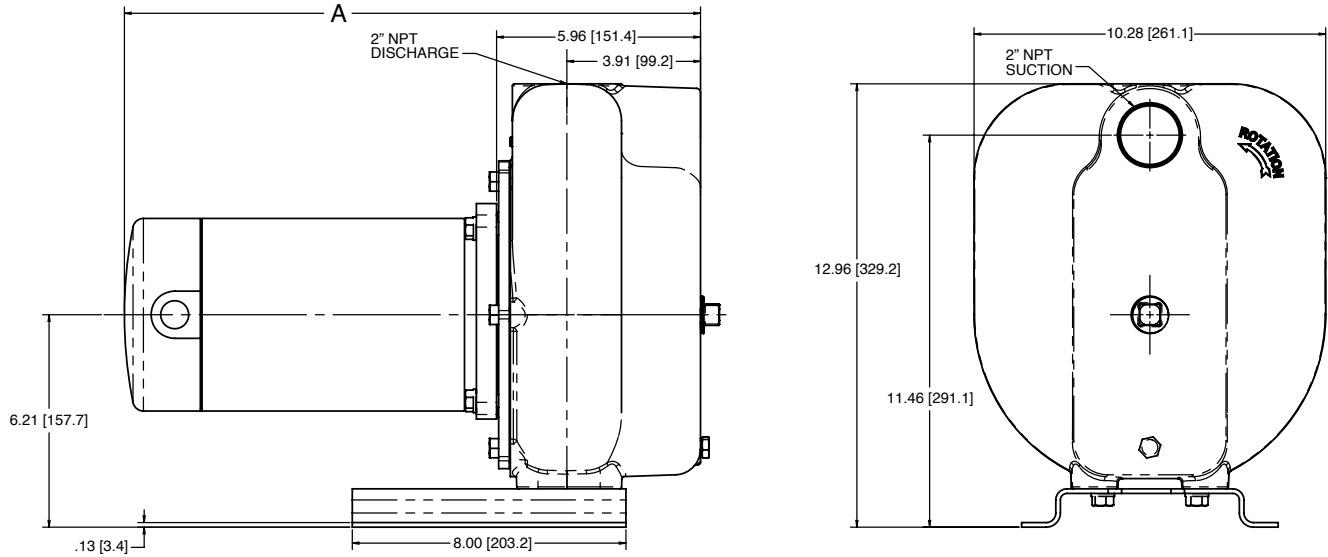

Cat. No	HP	A*
DS2HHG	2-1/2	18.59
DS2HG	2	18.59
DS2HF	1-1/2	17.84
DS2HE	1	16.96

\*Overall length (A) shown for single-phase motors. Three-phase motors are slightly smaller. Dimensions (in inches) are for estimating purposes only.

# PRO-Storm™ DS3 Series

Self-priming centrifugal

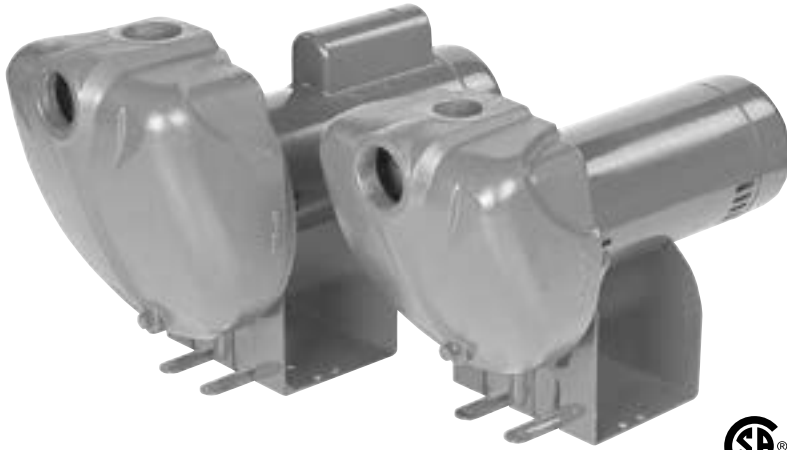

The Pro-Storm™ Series\* of cast iron sprinklers offers superior unmatched performance, available in 1 HP through 2-1/2 HP models.

The Pro-Storm models offer "single-body-fill" priming to 25-foot lifts, in less than 5 minutes!

The Pro-Storm models exceed the strict safety requirements of Underwriters Laboratories UL778, and CSA. Required by many state and local codes.

The Pro-Storm models are completely interchangeable with the original

Sta-Rite® DS3 Series models, saving costly plumbing "change-out" dollars and installation headaches!

\*Single- and three-phase available

## APPLICATIONS

Residential irrigation pump...can be safely operated by timer or other automatic device

Contractors...for dewatering excavation, water transfer and supply

Agriculture...seed bed and plot irrigation, stock watering

Industrial...sump drainage, marine pumping, liquid transfer and supply operations

## SPECIFICATIONS

**Body and Seal Plate:** Close-grained cast iron

**Impeller:** Noryl®

**Diffuser:** Reinforced polypropylene

**Shaft:** One-piece threaded 300 grade stainless steel

**Base:** Steel, 10 gauge

**Motor:** 2-compartment

## FEATURES

**Rugged Construction:** Close-grained cast iron body, specially treated for corrosion resistance.

**Noryl Impeller:** Precision-molded for perfect balance...ultra-smooth for highest performance and efficiency.

**Precision-Molded Diffuser:** Pump primes faster, handles more air, with multi-port, precision-molded, reinforced polypropylene diffuser.

**High Head Models:** Deliver up to 145' of head with capacities to 95 GPM.

**Easy Serviceability:** Normal wearing parts are easily accessible for service and replacement, without disturbing piping or mounting.

**Motor Windings:** Superior insulation materials protect against excessive moisture and contaminants...ensures prolonged motor life.

**Balanced Rotor:** Diecast under high pressures for uniform performance and greater efficiency, dynamically balanced.

**Drain Port:** Provided for easy winterizing.

## ORDERING INFORMATION

Catalog Number	HP	Voltage	Phase	High Head		Approx. Wt. Lbs.
				Pipe Tapping Sizes		
				Suction	Discharge	
DS3HE	1	115/230	1	2"	1-1/2"	52
DS3HE3	1	208-230/460	3	2"	1-1/2"	52
DS3HF	1-1/2	115/230	1	2"	1-1/2"	58
DS3HF3	1-1/2	208-230/460	3	2"	1-1/2"	58
DS3HG	2	115/230	1	2"	2"	83
DS3HG3	2	208-230/460	3	2"	2"	83
DS3HHG	2-1/2	115/230	1	2"	2"	85
DS3HHG3	2-1/2	208-230/460	3	2"	2"	85

NOTE: All single-phase motors shipped from the factory set at 230 volt.

Pentair trademarks and logos are owned by Pentair plc or its affiliates. All other third party registered and unregistered trademarks and logos are the property of their respective owners.

# PRO-Storm™ DS3 Series

Self-priming centrifugal

## PUMP PERFORMANCE

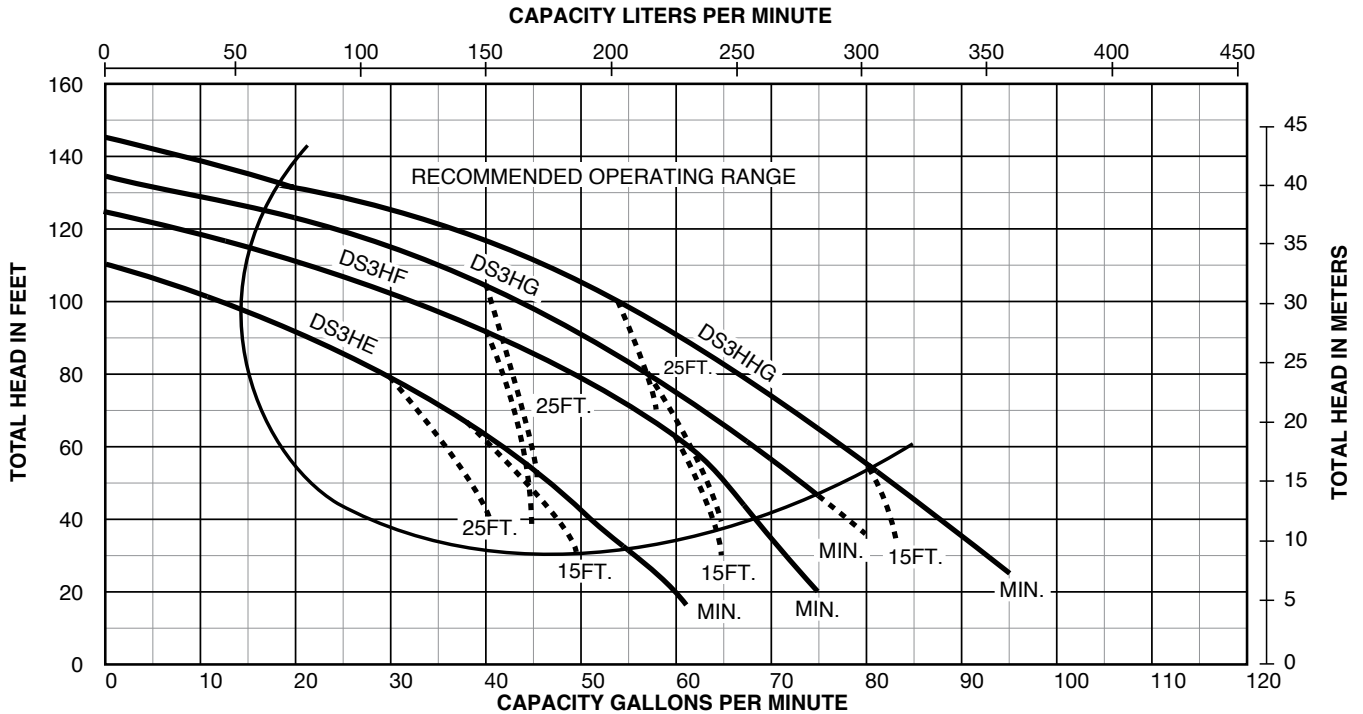

NOTE: Dotted lines indicate performance reduction at high suction lift.

## PUMP PERFORMANCE (Capacity in gallons per minute)

Catalog Number	HP	Discharge Pressure		Suction Lift in Feet				
		PSI	Feet Head	5'	10'	15'	20'	25'
DS3HE	1	20	46.2	48	45	40	37	33
		30	69.3	33	30	26	22	16
		40	92.4	15	10	—	—	—
DS3HF	1-1/2	20	46.2	64	62	60	57	54
		30	69.3	53	50	46	42	37
		40	92.4	35	30	25	19	—
DS3HG	2	20	46.2	72	70	67	65	62
		30	69.3	60	58	54	51	47
		40	92.4	45	42	37	30	27
		50	115.5	23	16	—	—	—
DS3HHG	2-1/2	20	46.2	83	80	77	74	71
		30	69.3	70	67	63	60	55
		40	92.4	56	52	48	40	35
		50	115.5	36	28	20	—	—

Tested and rated in accordance with Water Systems Council Standards.

NOTE: Pumps installed with a Pro-Source® tank require a 100 PSI relief valve. Pumps installed with a conventional tank require a 75 PSI relief valve. Relief valve must be capable of relieving entire flow of pump at relief pressure.

# PRO-Storm™ DS3 Series

Self-priming centrifugal

## OUTLINE DIMENSIONS

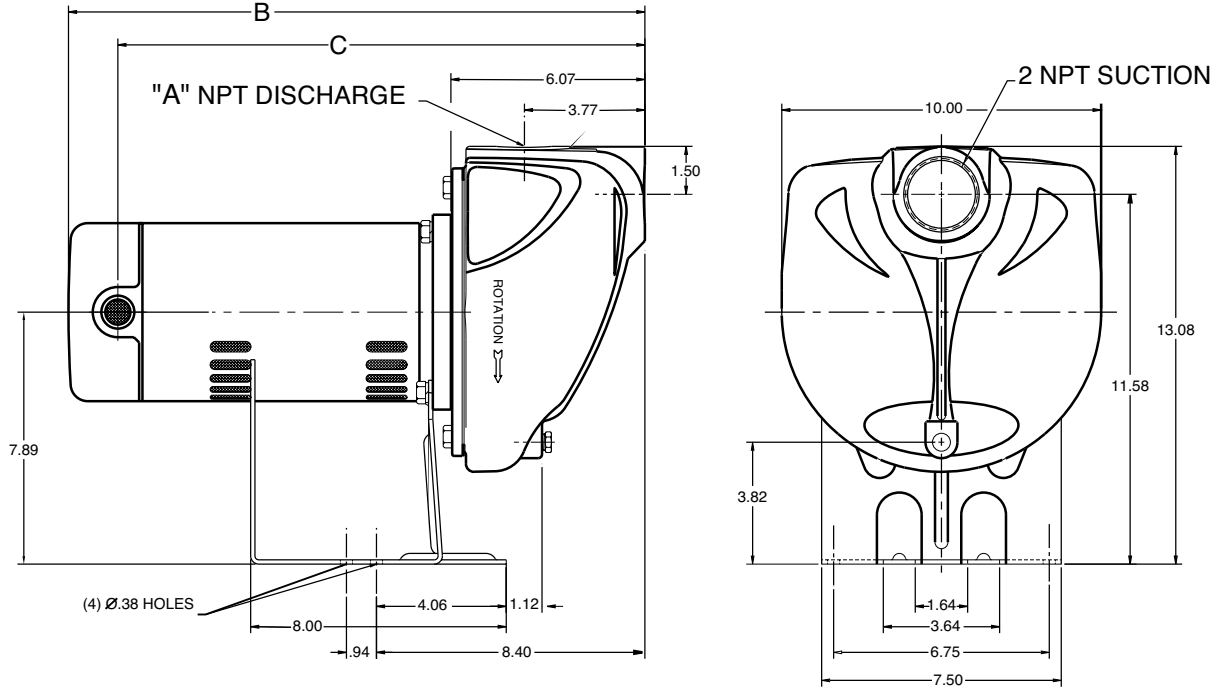

Catalog Number	A NPT	B	C
DS3HE	1-1/2" NPT	17.04	15.60
DS3HE3	1-1/2" NPT	15.45	14.07
DS3HF	1-1/2" NPT	18.10	16.66
DS3HF3	1-1/2" NPT	15.95	14.48
DS3HG	2" NPT	18.54	17.10
DS3HG3	2" NPT	16.95	15.48
DS3HHG	2" NPT	18.85	17.41
DS3HHG3	2" NPT	17.69	16.23

Dimensions (in inches) are for estimating purposes only.

# PD Series

Corrosion-resistant, self-priming sprinkler pumps



Quick priming PD Series Pumps feature lightweight construction in a self-priming design. These models offer a stronger pump body with reinforcement ribs and also a new 2" suction that is designed for the professional pump contractor.

## APPLICATIONS

Lawn and landscape sprinkling; self-priming out of tanks or cisterns.

Light chemical transfer for compatible fluids.

## SPECIFICATIONS

**Body and Base:** Fiberglass-reinforced thermoplastic

**Impeller:** Engineered polymer

**Diffuser:** Polypropylene

**Shaft:** 300 grade stainless steel

## FEATURES

**Quality Construction:** Fiberglass-reinforced thermoplastic provides total corrosion resistance and high resistance to sandy water.

**Lightweight Design:** Space-age materials make these pumps more portable than conventional cast iron pumps.

**Composite Impeller:** Highest performance and efficiency from ultra-smooth materials Precision-Molded for perfect balance.

**Easily Serviced:** Normal wearing parts are easily accessible for service and replacement, without disturbing piping or mounting.

**Dustproof Cover:** Electrical components protected from dust and insects.

**Heavy-Duty Motor:** Heavy-duty 1 through 2-1/2 HP motors. Designed for continuous operation. Stainless steel shaft.

**Dual Voltage Capability:** 1 and 1-1/2 HP motors have dual voltage motors and are shipped at the 230-volt setting. 2 and 2-1/2 HP are 230-volt setting only.

## ORDERING INFORMATION

Catalog Number	HP	Pipe Tapping Sizes		Motor Voltage	Approx. Wt. Lbs.
		Suction	Discharge		
PD2HE	1	2"	1-1/2"	115/230	38
PD2HF	1-1/2	2"	1-1/2"	115/230	41
PDHG	2	2"	2"	115/230	52
PDHHG	2-1/2	2"	2"	115/230	54

NOTE: All motors are shipped from the factory set at 230 volt.

# PD Series

Corrosion-resistant, self-priming sprinkler pumps

## OUTLINE DIMENSIONS

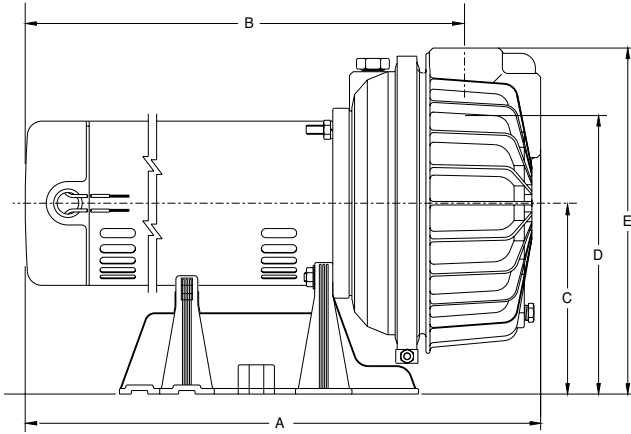

Catalog Number	A	B	C	D	E
PD2HE	17-5/8	15-1/8	6-9/16	9-9/16	11-13/16
PD2HF	18-3/4	16-1/4	6-9/16	9-9/16	11-13/16
PDHG	20	16-3/16	6-9/16	8-7/8	12-3/8
PDHGG	20	16-3/16	6-9/16	8-7/8	12-3/8

Dimensions (in inches) are for estimating purposes only.

## PERFORMANCE (Capacity in gallons per minute)

Disch. Press. PSI	PD2HE - 1 HP					PD2HF - 1.5 HP					PDHG - 2 HP					PDHGG - 2.5 HP				
	Distance Above Water																			
	5'	10'	15'	20'	25'	5'	10'	15'	20'	25'	5'	10'	15'	20'	25'	5'	10'	15'	20'	25'
10	53	52	50	48	46	67	66	64	61	59	70	69	67	64	62	90	88	86	82	80
20	45	42	39	37	35	59	56	54	50	47	61	59	56	53	50	79	76	72	70	65
30	35	31	27	24	18	48	44	40	37	32	50	48	44	41	37	66	62	57	55	50
40	17	10				31	26	20	10		36	33	25	23	19	50	45	42	37	32
50											16	9				30	23	20		

## PUMP PERFORMANCE

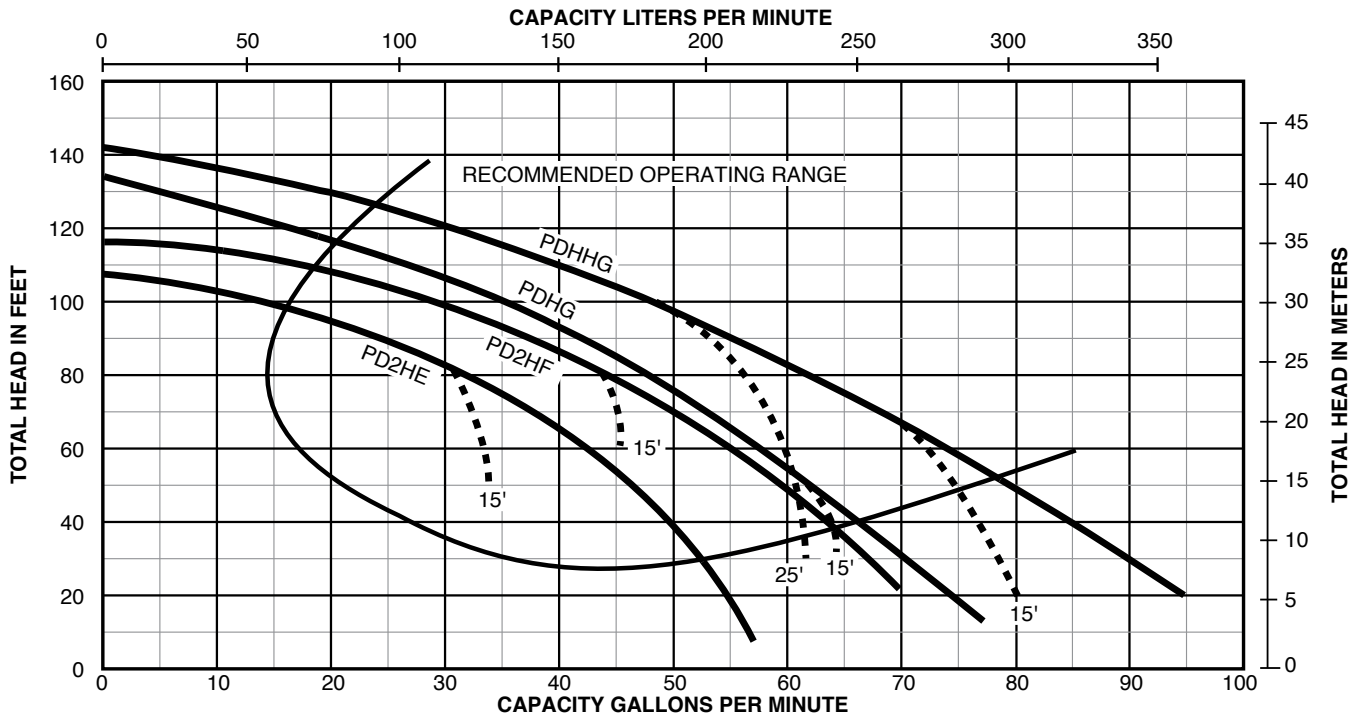

NOTE: Dotted lines indicate performance reduction at high suction lift.

# D Series

Self-priming centrifugal pumps

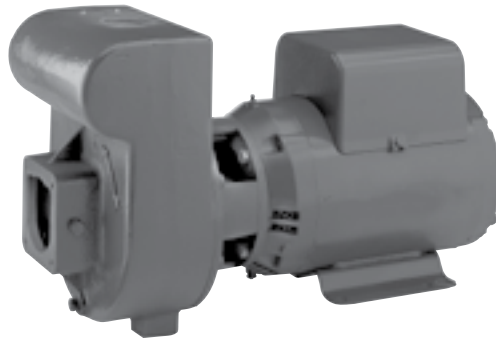

3 and 5 HP

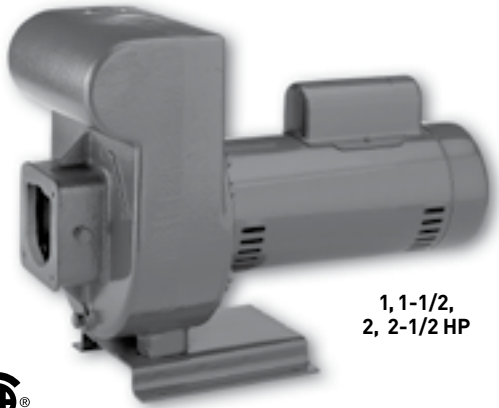

1, 1-1/2,  
2, 2-1/2 HP



Order suction flange with flapper check separately.

Some of the fastest priming pumps on the market. Available in high head or medium head series. Features mechanical seals, easy service design, heavy-duty motors, rugged construction. Available in 1 through 5 HP.

Optional 6" and 8" Trap Packages are available.

## APPLICATIONS

**Lawn Sprinkling...**operate from 1 to 30 or more heads. Can be safely operated by timer or other automatic device.

**Contractors...**for dewatering excavation, jetting, water transfer and supply operations.

**Agriculture...**seed bed and plot irrigation, stock watering, fire protection.

**Industrial...**sump drainage, fire protection, marine pumping, liquid transfer and supply operations.

## SPECIFICATIONS

**Body and Base:** Close-grained cast iron

**Impeller:** Noryl® on 1 through 2-1/2 HP, bronze on 3 and 5 HP

**Diffuser:** Cast iron

**Shaft:** 1 through 2-1/2 HP: 416 stainless steel; 3 and 5 HP: Carbon steel inside removable shaft sleeve of stainless steel.

**Max Inlet Pressure:** 20 PSI

**Max Discharge Pressure:** 100 PSI

**Max Liquid Temperature:** 60°C/140°F

**Max Ambient Air Temperature:** 40°C/104°F

## FEATURES

**1 through 5 HP:** Both high head and medium head models offer heavy-duty motors, easy service design, and air volume control tapping.

**Drain Port:** Provided for easy winterizing.

**Medium Head Models:** Deliver up to 115' of head with capacities to 159 GPM.

**High Head Models:** Deliver up to 138' of head with capacities to 162 GPM.

**Easy Serviceability:** Normal wearing parts are easily accessible for service and replacement, without disturbing piping or mounting.

**Heavy-Duty Motors:** Designed for continuous operation. Capacitor start, will not cause electrical interference with TV or other appliances. Nationally known motors have ball bearing, stainless steel shaft. For single- and three-phase operation, 3450 RPM.

# D Series

Self-priming centrifugal pumps

## ORDERING INFORMATION

### HIGH HEAD

Catalog Number	HP	Pipe Tapping Sizes			Motor Voltage	Phase	Approx. Wt. Lbs.
		Suction Flanges*	Top Discharge	Side Discharge**			
DHE	1	PKG 53	1-1/2"	1-1/2"	115/230	1	65
DHE3	1	PKG 53	1-1/2"	1-1/2"	208-230/460	3	65
DHF	1-1/2	PKG 53	1-1/2"	1-1/2"	115/230	1	72
DHF3	1-1/2	PKG 53	1-1/2"	1-1/2"	208-230/460	3	72
DHG	2	PKG 72	2"	-	115/230	1	113
DHG3	2	PKG 72	2"	-	208-230/460	3	113
DHHG	2-1/2	PKG 72	2"	-	115/230	1	120
DHHG3	2-1/2	PKG 72	2"	-	208-230/460	3	120
DH2H	3	PKG 53	2"	-	200	1	144
DHH	3	PKG 53	1-1/2"	-	230	1	144
DH2H3	3	PKG 53	2"	-	200	3	144
DHH3	3	PKG 53	1-1/2"	-	208-230/460	3	144
DH2J	5	PKG 72	2"	-	200	1	184
DHJ	5	PKG 72	2"	-	230	1	184
DH2J3	5	PKG 72	2"	-	200	3	184
DHJ3	5	PKG 72	2"	-	208-230/460	3	184

### MEDIUM HEAD

DMG	2	PKG 53	1-1/2"	1-1/2"	115/230	1	86
DMG3	2	PKG 53	1-1/2"	1-1/2"	208-230/460	3	86
DMMG	2-1/2	PKG 72	2"	1-1/2"	115/230	1	93
DMMG3	2-1/2	PKG 72	2"	1-1/2"	208-230/460	3	93
DM2H	3	PKG 72	2-1/2"	-	200	1	127
DMH	3	PKG 72	2"	-	230	1	137
DM2H3	3	PKG 72	2-1/2"	-	200	3	137
DMH3	3	PKG 72	2"	-	208-230/460	3	137
DM2J	5	PKG 73	3"	-	200	3	184
DMJ	5	PKG 73	2-1/2"	-	230	1	184
DM2J3	5	PKG 73	3"	-	200	3	184
DMJ3	5	PKG 73	2-1/2"	-	230/460	3	184

\*Suction flanges must be ordered separately. See chart below.

\*\*Pumps with Side discharge Tap of 1-1/2" are shipped with a 1-1/2" Square Head Pipe Plug in tap.

### SUCTION FLANGES (Order separately – required for suction tap sizes)

Package 52 -	Package 53 -	Package 72 -	Package 73 -
1-1/2"	2"	2-1/2"	3"



PKG 52

1-1/2"

PKG 53

2" NPT



PKG 72

2-1/2"

PKG 73

3" NPT

# D Series

Self-priming centrifugal pumps

## 6" AND 8" TRAP PACKAGES

Catalog Number	Description	Suction Port Size	Approx. Wt. Lbs.
PKG 51	6" Cast Iron Trap with Basket (For C, CC, and D Series Pumps)	2" NPT	20
PKG 76	Cast Iron Flange for Remote Installation	3" NPT	4
PKG 98	8" Cast Iron Trap with Basket (For C, CC, and D Series Pumps)	3" NPT	40

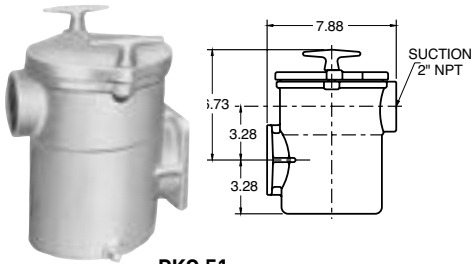

**PKG 51**  
6-INCH TRAP

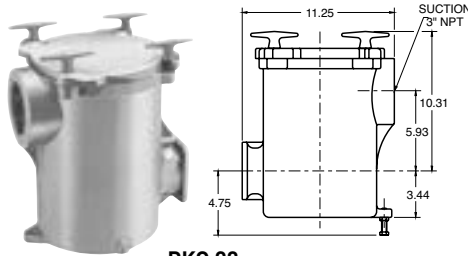

**PKG 98**  
8-INCH TRAP



**PKG 76**

## SUCTION TRAP PSI LOSS CURVE

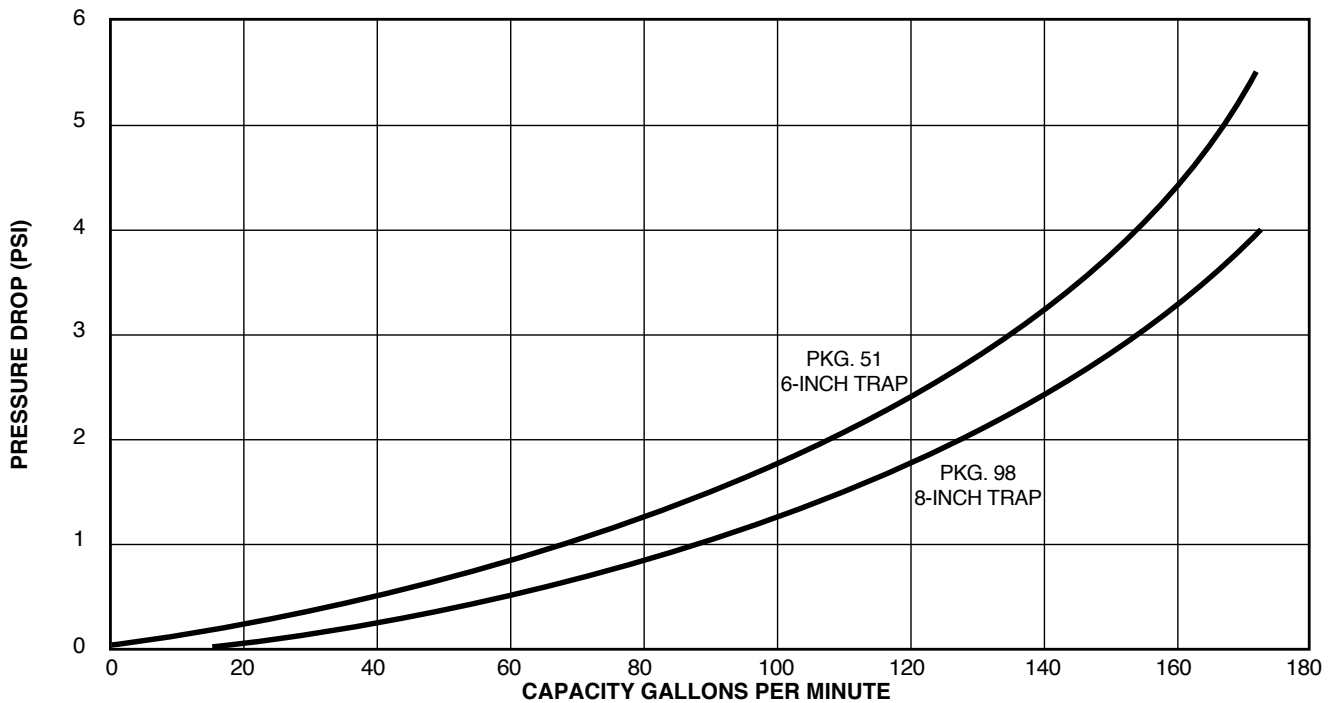

# D Series

Self-priming centrifugal pumps

## PUMP PERFORMANCE: HIGH HEAD

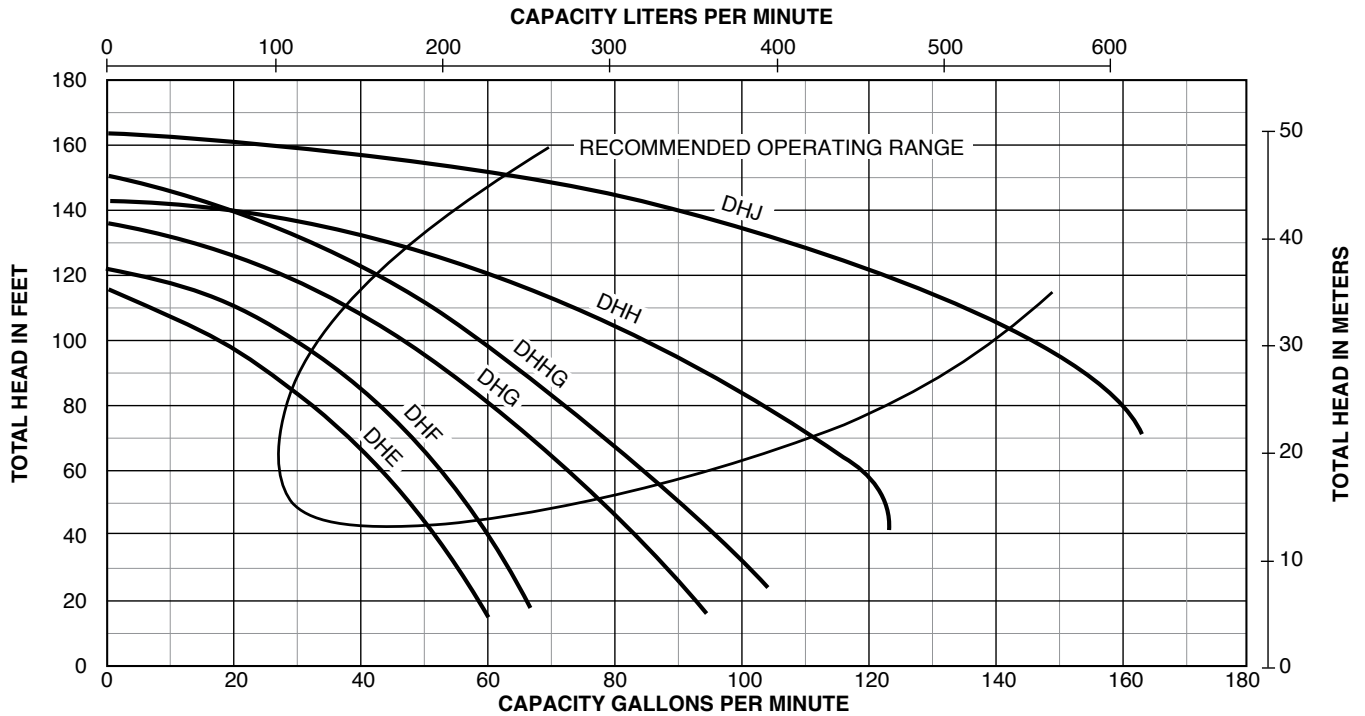

### PUMP PERFORMANCE (CAPACITY IN GALLONS PER MINUTE)

#### HIGH HEAD

Cat. No.	HP	Discharge		Suction Lift in Feet				
		PSI	Feet Head	5'	10'	15'	20'	25'
DHE	1	20	46.2	46	43	41	40	38
		30	69.3	35	32	29	25	21
		40	92.4	19	15	-	-	-
		50	115.5	-	-	-	-	-
		60	138.6	-	-	-	-	-
DHF	1-1/2	20	46.2	55	53	51	49	48
		30	69.3	45	42	39	36	32
		40	92.4	31	27	22	15	-
		50	115.5	-	-	-	-	-
		60	138.6	-	-	-	-	-
DHG	2	20	46.2	77	74	71	68	65
		30	69.3	63	60	56	53	49
		40	92.4	48	44	40	36	30
		50	115.5	30	20	13	-	-
		60	138.6	-	-	-	-	-

### PUMP PERFORMANCE (CAPACITY IN GALLONS PER MINUTE)

#### HIGH HEAD

Cat. No.	HP	Discharge		Suction Lift in Feet				
		PSI	Feet Head	5'	10'	15'	20'	25'
DHHG	2-1/2	20	46.2	89	85	82	80	76
		30	69.3	75	72	68	64	60
		40	92.4	60	57	51	49	42
		50	115.5	42	37	31	25	20
		60	138.6	14	-	-	-	-
DHH	3	20	46.2	-	-	-	112	109
		30	69.3	109	103	98	92	89
		40	92.4	90	75	74	69	62
		50	115.5	62	51	42	32	20
		60	138.6	-	-	-	-	-
DHJ	5	20	46.2	-	-	-	-	-
		30	69.3	-	-	-	-	-
		40	92.4	146	141	136	130	122
		50	115.5	122	114	105	99	85
		60	138.6	81	70	50	30	-

# D Series

Self-priming centrifugal pumps

## PUMP PERFORMANCE: MEDIUM HEAD

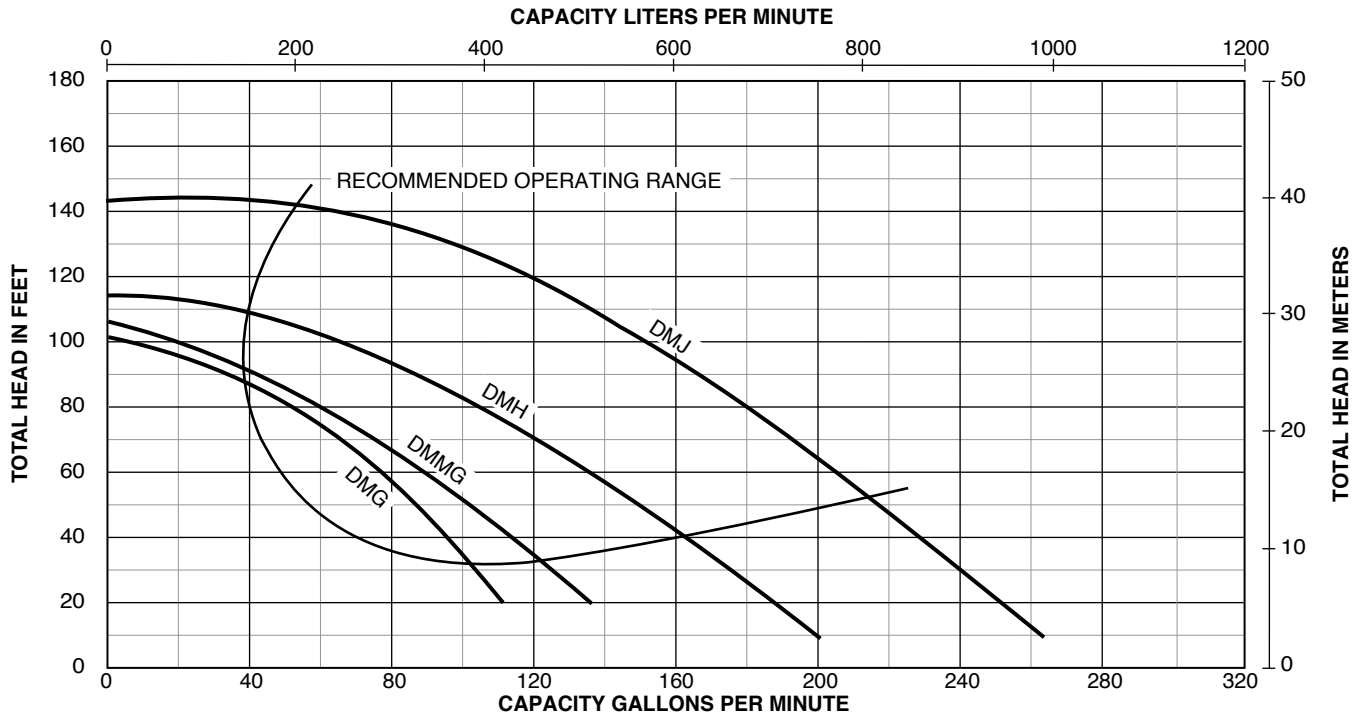

## PUMP PERFORMANCE (CAPACITY IN GALLONS PER MINUTE)

### MEDIUM HEAD

Pump Model	Capacity (GPM)	Total Head (Feet)							
		20	30	40	50	60	70	80	
DMG	2	20	46.2	84	79	74	69	63	
		30	69.3	60	53	46	35	20	
		40	92.4	22	-	-	-	-	-
		50	115.5	-	-	-	-	-	-
DMMG	2-1/2	20	46.2	103	96	90	80	70	
		30	69.3	70	60	50	46	30	
		40	92.4	30	18	5	-	-	
		50	115.5	-	-	-	-	-	
DMH	3	20	46.2	149	140	136	124	119	
		30	69.3	116	108	99	85	76	
		40	92.4	75	65	51	26	-	
		50	115.5	-	-	-	-	-	
DMJ	5	20	46.2	214	209	202	194	182	
		30	69.3	185	179	172	165	158	
		40	92.4	153	146	139	130	120	
		50	115.5	119	107	95	80	50	

# D Series

Self-priming centrifugal pumps

## OUTLINE DIMENSIONS

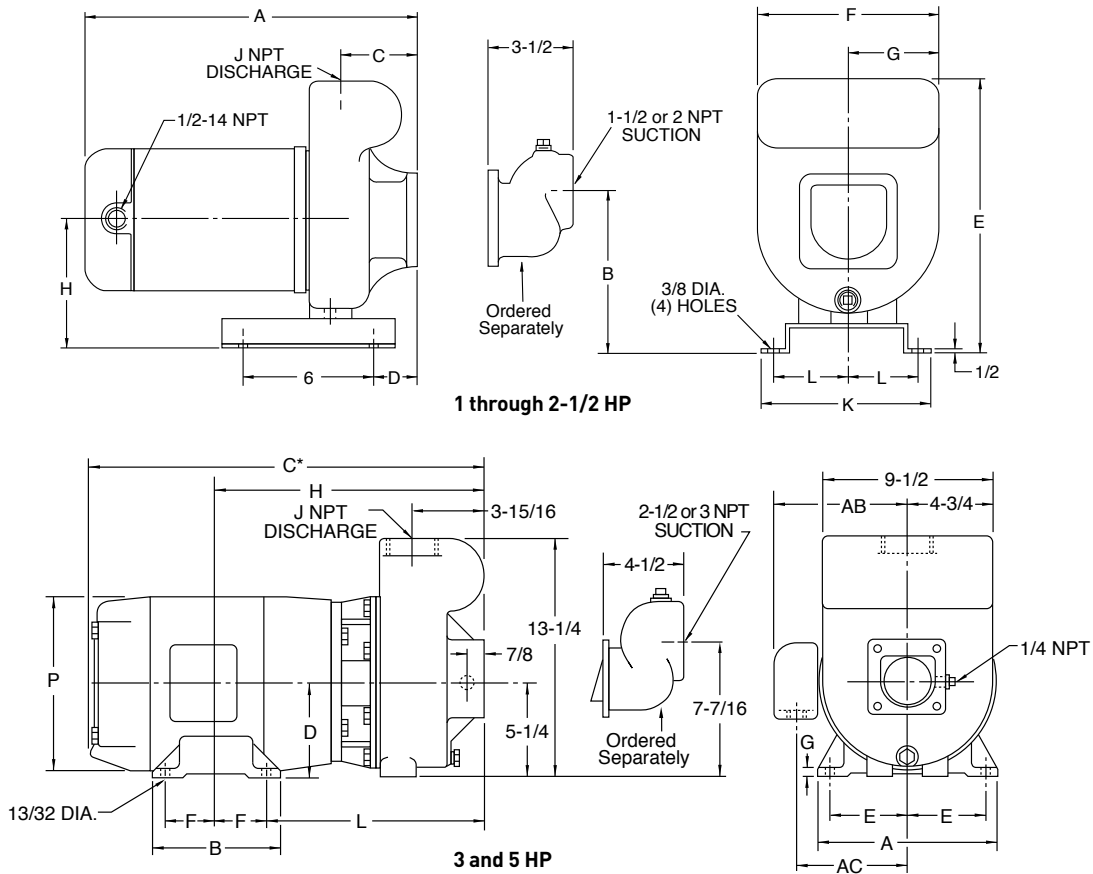

Dimensions (in inches) are for estimating purposes only.

### DIMENSIONS IN INCHES: 1 THROUGH 2-1/2 HP

Catalog Number	HP	A	B	C	D	E	F	G	H	J	K	L
DHE**	1	14-13/16	7-1/16	3-1/2	4	11-7/8	7-7/8	3-15/16	5-13/16	1-1/2	7-1/2	3-3/8
DHF**	1-1/2	15-11/16	7-1/16	3-1/2	4	11-7/8	7-7/8	3-15/16	5-13/16	1-1/2	7-1/2	3-3/8
DHG	2	17-11/16	7-13/16	3-15/16	3-13/16	14-3/8	9-1/2	4-3/4	6-9/16	2	7-1/2	3-3/8
DHHG	2-1/2	18-11/16	7-13/16	3-15/16	3-13/16	14-3/8	9-1/2	4-3/4	6-9/16	2	7-1/2	3-3/8
DMG**	2	16-15/16	7-1/16	3-1/2	4	11-7/8	7-7/8	3-15/16	5-13/16	1-1/2	7-1/2	3-3/8
DMMG**	2-1/2	17-15/16	7-1/16	3-1/2	4	11-7/8	7-7/8	3-15/16	5-13/16	2	7-1/2	3-3/8

### DIMENSIONS IN INCHES: 3 AND 5 HP

Catalog Number	HP	A	B	C*	D	E	F	G	H	J	L	P	AB	AC
DHH	3	9	6	20-3/4	4-1/2	3-3/4	2-1/4	1/2	15	1 - 1/2"	12-3/4	9-3/4	8-1/8	6-1/2
DHJ	5	9	7	21-3/4	4-1/2	3-3/4	2-3/4	1/2	15-1/2	2"	12-3/4	9-3/4	9	7
DMH	3	9	6	20-3/4	4-1/2	3-3/4	2-1/4	1/2	15	2"	12-3/4	9-3/4	8-1/8	6-1/2
DMJ	5	9	7	21-3/4	4-1/2	3-3/4	2-3/4	1/2	15-1/2	2 - 1/2"	12-3/4	9-3/4	9	7

\*Overall length (C) is shown for single-phase motors. Three-phase motors are slightly smaller. Dimensions are for estimating purposes only.

\*\*Pump body has additional built in 1-1/2" NPT side discharge tap.

# CC Series

Straight centrifugal pumps



Optional Flange and Trap Packages Available

The CC Series Pumps are compact and lightweight, but rugged. Choose from 3 or 5 HP high head and medium head models. For lower pressures and maximum capacity, medium head models offer heads to 75 feet and capacities to 220 GPM. Where higher pressures are desired, the high head model offers heads to 102 feet and capacities to 260 GPM.

## APPLICATIONS

**Water Systems**  
**Sprinkling for homes, farms and industry**

See page 133 for flange and trap packages.

## SPECIFICATIONS

**Body:** Close-grained cast iron

**Base:** Heavy-gauge steel

**Impeller:** Silicon brass (non-lead)

**Rugged Motors:** 3 to 5 HP, 3450 RPM, open drip-proof, continuous-duty rated. 40°C ambient maximum, NEMA series, JM construction.

**Shaft:** Carbon steel inside a 300 Series stainless steel sealed removable shaft sleeve.

**Bearings:** Permanently sealed ball type, pre-lubricated.

**Thermal Overload Protection:** Single-phase motors: automatic reset; Three-phase motors: external thermal protection required.

**Max. Liquid Temperature:** 125°F

**Ambient Air Temperature:** 104°F

**Max. Pressure:** 75 PSI

## FEATURES

**Compact and Lightweight:** Can be installed where most other 3 and 5 HP pumps will not fit...requires just 11-3/8" x 18-1/2". Complete pumps weigh only 66 to 94 lbs.

**4-Position Discharge:** Permits installation with discharge horizontal or vertical, to right or left. Volute features drain port which is functional when discharge is vertical.

**Silicon Brass Impeller and Wear Ring:** Silicon brass impeller is precision cast and machined. Dynamically balanced for long seal life and quiet operation. Non-overloading. Contains no lead. Silicon brass wear ring is replaceable.

**Easy Service:** Back pull-out design: entire motor may be removed for servicing impeller, seal or motor without disturbing plumbing. Centerline discharge for ease of installation.

**Shaft Seal:** Mechanical, ceramic and carbon seal faces. Stainless steel spring and Buna-N bellows.

## ORDERING INFORMATION

HIGH HEAD						
Catalog Number	HP	Pipe Tapping Sizes		Motor Voltage*	Phase	Approx. Wt. Lbs.
		Suction	Discharge			
CCH2H	3	2-1/2"	2"	200	1	80
CCHH	3	2-1/2"	2"	230	1	80
CCH2H3	3	2-1/2"	2"	200	3	66
CCHH3	3	2-1/2"	2"	230/460	3	66
CCH2J	5	2-1/2"	2"	200	1	94
CCHJ	5	2-1/2"	2"	230	1	94
CCH2J3	5	2-1/2"	2"	200	3	80
CCHJ3	5	2-1/2"	2"	230/460	3	80
MEDIUM HEAD						
CCM2H	3	2-1/2"	2"	200	1	80
CCMH	3	2-1/2"	2"	230	1	80
CCM2H3	3	2-1/2"	2"	200	3	66
CCMH3	3	2-1/2"	2"	230/460	3	66

Maximum load amps may vary with motor suppliers.

\*200-volt and 575-volt models are available. Consult factory.

# CC Series

Straight centrifugal pumps

## PUMP PERFORMANCE

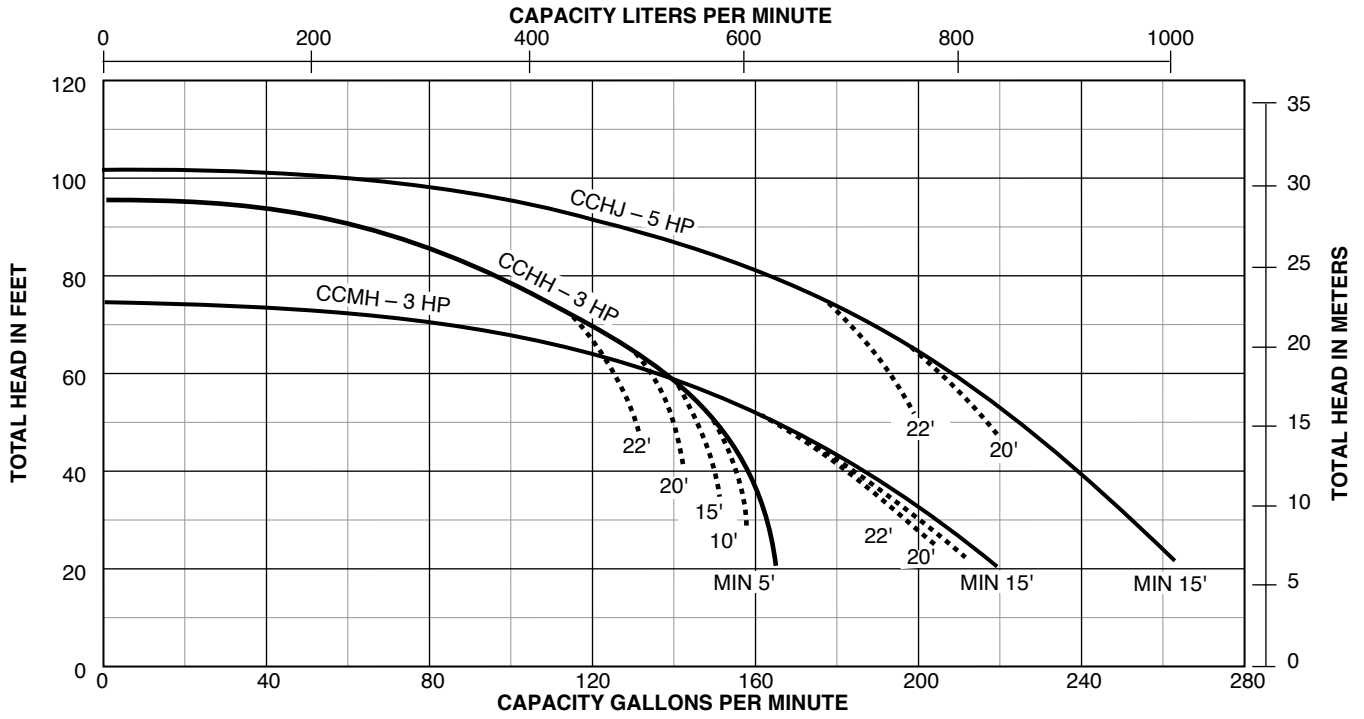

NOTE: Dotted lines indicate performance reduction at high suction lift.

## PUMP PERFORMANCE (Capacity in gallons per minute)

Cat. No.	HP	HIGH HEAD						
		Discharge Pressure		Dynamic Suction Lift				
		PSI	Feet Head	5'	10'	15'	20'	22'
CCHH	3	20	46.2	148	142	134	125	120
		30	69.3	110	98	85	60	57
		40	92.4	-	-	-	-	-
CCHJ	5	20	46.2	222	214	205	196	190
		30	69.3	180	166	152	125	120
		40	92.4	90	-	-	-	-
<b>MEDIUM HEAD</b>								
CCMH	3	20	46.2	165	148	133	112	100
		30	69.3	-	-	-	-	-
		40	92.4	-	-	-	-	-

Tested and rated in accordance with Water Systems Council Standards.

NOTE: Pumps installed with a Pro-Source® tank require a 100 PSI relief valve. Pumps installed with a conventional tank require a 75 PSI relief valve. Relief valve must be capable of relieving entire flow of pump at relief pressure.

# CC Series

Straight centrifugal pumps

## OUTLINE DIMENSIONS

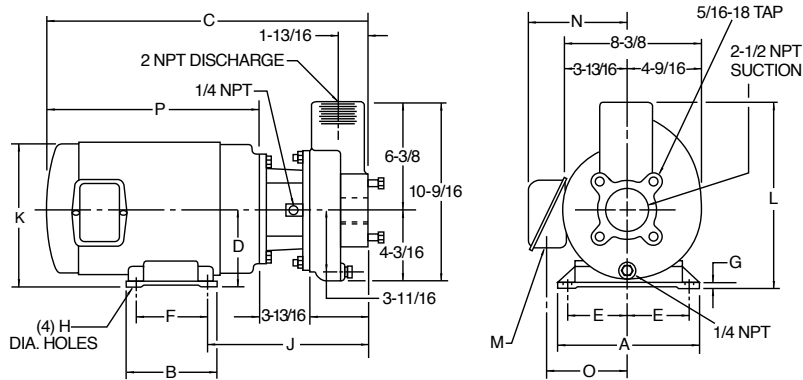

Dimensions (in inches) are for estimating purposes only.

## DIMENSIONAL DATA

Catalog Number	A	B	C*	D	E	F	G*	H*	J	K	L	M*	N*	O*	P*
CCHH CCMH	9	6-1/2	21-1/2	4-1/2	3-3/4	4-1/2	7/16	7/16	10-5/16	9-23/32	10-7/8	3/4	8-1/8	6-1/2	14-1/8
CCHH3 CCMH3	7	6	18-13/32	3-1/2	2-3/4	5	9/32	11/32	9-9/32	7-7/32	9-7/8	3/4	6-29/32	5-13/32	11
CCHJ CCHJ3	9	7-1/2	22-1/2	4-1/2	3-3/4	5-1/2	7/16	7/16	10-5/16	9-23/32	10-7/8	3/4	9	6-15/16	15-1/8

\*Dimensions may vary with motor supplier.

# DPC Series

Self-priming centrifugal pump



The DPC Series self-priming centrifugal pump is a rugged cast iron pump capable of priming up to 20' vertically and will handle solids up to 0.225" diameter. The unit is equipped with a 1/2 HP 115-volt motor and features 1-1/4" suction and discharge.

## APPLICATIONS

Effluent and Wastewater Removal  
Sump Drainage  
Dewatering  
Circulation  
Fountains

## SPECIFICATIONS

**Volute:** Cast iron

**Impeller:** Polycarbonate

**Diffuser:** Thermoset

**Shaft:** One-piece threaded stainless steel

**Base:** Steel 12 gauge

**Maximum Liquid Temperature Limits:**  
130°F (55°C)

## FEATURES

**Motor:** 1/2 HP, 3450 RPM, 115-volt split phase, 60 Hz. Built-in thermal overload protection with automatic reset.

**Mechanical Seal:** Buna-N elastomers, carbon and ceramic sealing faces, stainless steel metal part.

**Heavy-Duty Ball Bearings:** Shielded, permanently lubricated bearings, extensively tested to ensure extended life and smooth, quiet operation.

**Built-in Convenience:** Comes complete with built-in overload protection with automatic reset and a built-in check valve.

**Power Cord:** 10', 115 volt.

## ORDERING INFORMATION

Catalog Number	HP	Volts	Phase/Cycles
DPC	1/2	115	1/60

# DPC Series

Self-priming centrifugal pump

## PUMP PERFORMANCE

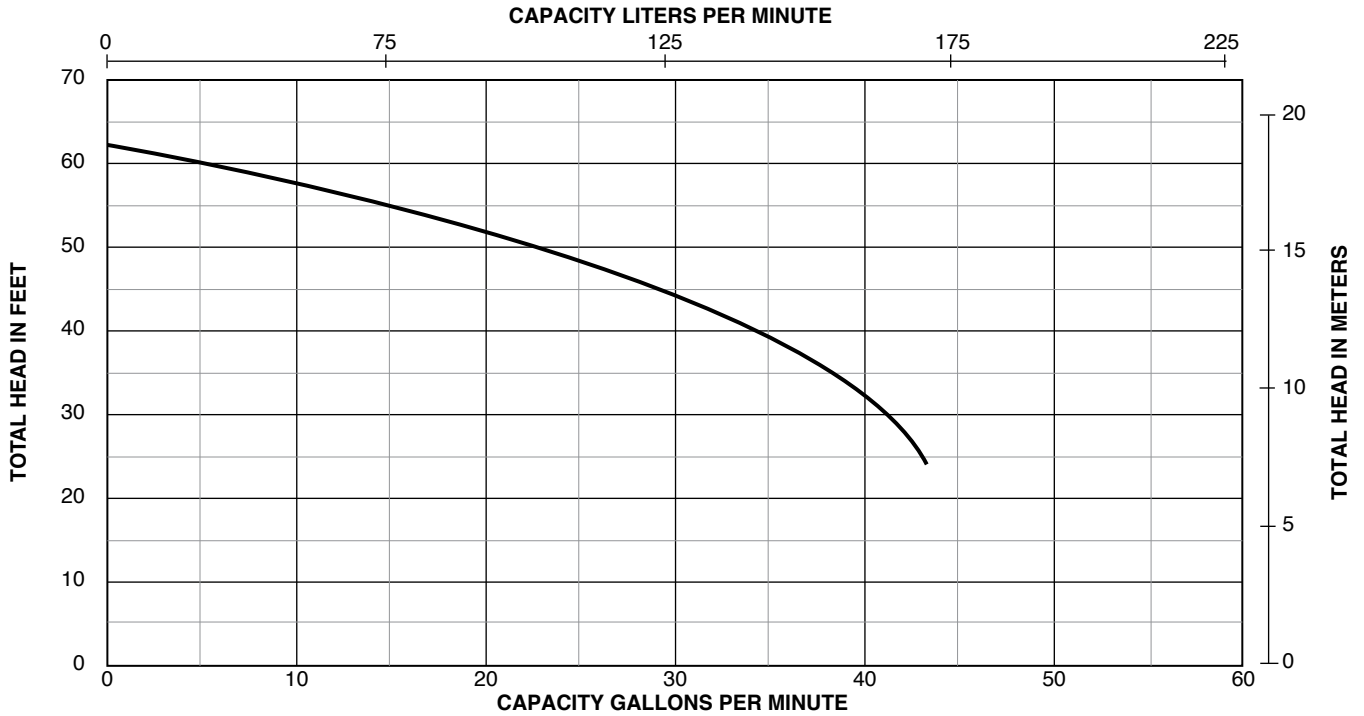

## OUTLINE DIMENSIONS

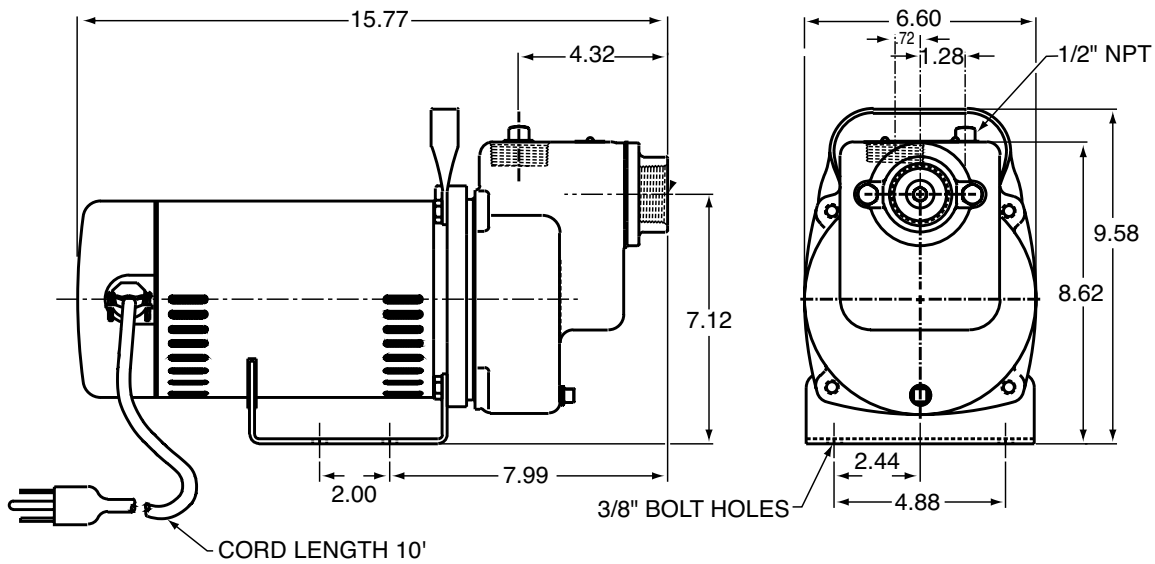

NOTE: 1-1/4" SUCTION AND DISCHARGE  
ALL DIMENSIONS ± .06

Dimensions (in inches) are for estimating purposes only.

# J/JB Series

General purpose centrifugal pumps



The J/JB Series Pumps have a heavy-duty cast iron construction and are offered in high and medium head models, with Noryl® or silicon bronze impeller.

## APPLICATIONS

**Water systems and sprinkling...**  
for homes, farms and industry.

## SPECIFICATIONS

**Body and Seal Plate:** Close-grained cast iron

**Base:** Steel 12 gauge

**Impeller:** J Series – Noryl

**Impeller:** JB Series – Silicon bronze

**Shaft:** 416 stainless steel

**Mechanical Seal:** Carbon/ceramic, Buna-N

## FEATURES

**1/3 through 2-1/2 HP:** High head and medium head models, with heavy-duty motors, easy service design and four-position discharge.

### Maximum Case Pressure:

JH & JBH – all HP max case 125PSI

JM & JBM – 1/3-1HP 75 PSI

JM & JBM – 1.5-2.5 HP 125 PSI

**Drain Port:** Provided for easy winterizing.

**Medium Head Models:** Deliver up to 110' of head with capacities to 140 GPM.

**High Head Models:** Deliver up to 140' of head with capacities to 90 GPM.

**Easy Serviceability:** All models include replaceable wear ring and feature back pull-out design.

### J Series with Noryl Impellers:

Abrasion-resistant for normal applications with working temperatures to 140°F.

### JB Series with Silicon Bronze:

JB pumps equipped with shaft seals rated for temperatures to 225°F.

## ORDERING INFORMATION

### HIGH HEAD

Catalog Number		HP	Pipe Tapping Sizes		Motor Voltage	Phase	Approx. Wt. Lbs.
Noryl® Impeller	Silicon Bronze Impeller		Suct.	Disch.			
JHB	JBHB	1/3	1-1/4"	1"	115/230	1	38
JHC	JBHC	1/2	1-1/4"	1"	115/230	1	39
JHC2	JBH2C		1-1/4"	1"	200	1	39
JHC3	JBHC3		1-1/4"	1"	208-230/460	3	39
JHD	JBHD	3/4	1-1/4"	1"	115/230	1	42
JH2D3	-		1-1/4"	1"	200	3	42
JHD3	JBHD3		1-1/4"	1"	208-230/460	3	42
JHE	JBHE	1	1-1/4"	1"	115/230	1	45
JH2E	JBH2E		1-1/4"	1"	200	1	45
JHE3	JBHE3		1-1/4"	1"	208-230/460	3	45
JHF	JBHF	1-1/2	1-1/4"	1"	115/230	1	49
JH2F	-		1-1/4"	1"	200	1	49
JH2F3	-		1-1/4"	1"	200	3	49
JHF3	JBHF3		1-1/4"	1"	208-230/460	3	49
JHG	JBHG	2	1-1/2"	1-1/4"	115/230	1	69
JHG3	-		1-1/2"	1-1/4"	200	3	69
JHG3	JBHG3		1-1/2"	1-1/4"	208-230/460	3	69
JHHG	JBHHG	2-1/2	2"	1-1/2"	115/230	1	74
JHHG3	JBHHG3		2"	1-1/2"	208-230/460	3	74

## ORDERING INFORMATION

### MEDIUM HEAD

Catalog Number		HP	Pipe Tapping Sizes		Motor Voltage	Phase	Approx. Wt. Lbs.
Noryl® Impeller	Silicon Bronze Impeller		Suct.	Disch.			
JMB	JBMB	1/3	1-1/4"	1"	115/230	1	38
JMC	JBMC	1/2	1-1/4"	1"	115/230	1	39
JMC3	JBMC3		1-1/4"	1"	208-230/460	3	39
JMD	JBMD	3/4	1-1/4"	1"	115/230	1	42
-	JBMD2D		1-1/4"	1"	200	1	42
-	JBMD3		1-1/4"	1"	200	3	42
JMD3	JBMD3		1-1/4"	1"	208-230/460	3	42
JME	JBME	1	1-1/2"	1-1/4"	115/230	1	43
JME	-		1-1/2"	1-1/4"	200	1	43
-	JBME2E3		1-1/2"	1-1/4"	200	3	43
JME3	JBME3		1-1/2"	1-1/4"	208-230/460	3	43
JMF	JBMF	1-1/2	1-1/2"	1-1/4"	115/230	1	54
JMF	-		1-1/2"	1-1/4"	200	1	54
-	JBMF2F3		1-1/2"	1-1/4"	200	3	54
JMF3	JBMF3		1-1/2"	1-1/4"	208-230/460	3	54
JMG	JBMG	2	1-1/2"	1-1/4"	115/230	1	66
-	JBMG2G3		1-1/2"	1-1/4"	200	3	66
JMG3	JBMG3		1-1/2"	1-1/4"	208-230/460	3	66
-	JBMMG	2-1/2	2"	1-1/2"	115/230	1	74
-	JBMMG3		2"	1-1/2"	208-230/460	3	74

Pentair trademarks and logos are owned by Pentair plc or its affiliates. All other third party registered and unregistered trademarks and logos are the property of their respective owners.

# J/JB Series

General purpose centrifugal pumps

## PUMP PERFORMANCE: HIGH HEAD

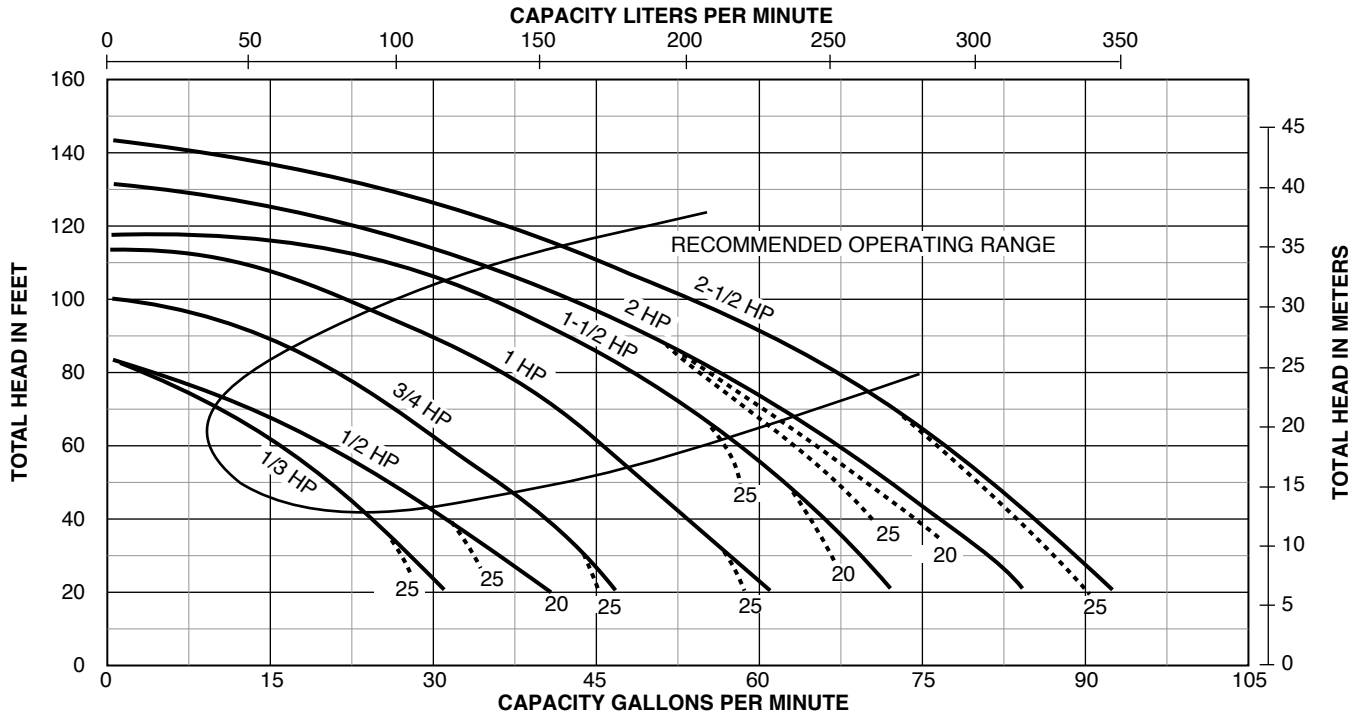

NOTE: Dotted lines indicate performance reduction at high suction lift.

### PUMP PERFORMANCE (Capacity in gallons per minute)

#### HIGH HEAD

HP	Discharge Pressure		Dynamic Suction Lift				
	PSI	Feet Head	5'	10'	15'	20'	25'
1/3	10	23.1	—	26	24	22	20
	20	46.2	20	18	15	11	10
	30	69.3	6	—	—	—	—
1/2	10	23.1	—	34	32	29	26
	20	46.2	25	21	18	15	11
	30	69.3	10	—	—	—	—
3/4	10	23.1	—	—	42	39	37
	20	46.2	35	32	30	28	26
	30	69.3	24	22	19	15	10
1	20	46.2	48	46	45	43	40
	30	69.3	38	35	31	28	25
	40	92.4	23	20	15	—	—

### PUMP PERFORMANCE (Capacity in gallons per minute)

#### HIGH HEAD

HP	Discharge Pressure		Dynamic Suction Lift				
	PSI	Feet Head	5'	10'	15'	20'	25'
1-1/2	20	46.2	62	60	58	55	52
	30	69.3	50	48	44	40	37
	40	92.4	37	32	29	22	—
2	20	46.2	71	68	66	62	60
	30	69.3	60	57	52	59	45
	40	92.4	45	40	36	31	24
	50	115.5	22	15	—	—	—
2-1/2	20	46.2	81	79	76	74	71
	30	69.3	69	67	63	60	56
	40	92.4	56	51	47	44	38
	50	115.5	33	30	22	15	—

Tested and rated in accordance with Water Systems Council Standards.

NOTE: Pumps installed with a Pro-Source® tank require a 100 PSI relief valve. Pumps with a conventional tank require a 75 PSI relief valve. Relief valve must be capable of relieving entire flow of pump at relief pressure.

# J/JB Series

General purpose centrifugal pumps

## PUMP PERFORMANCE: MEDIUM HEAD

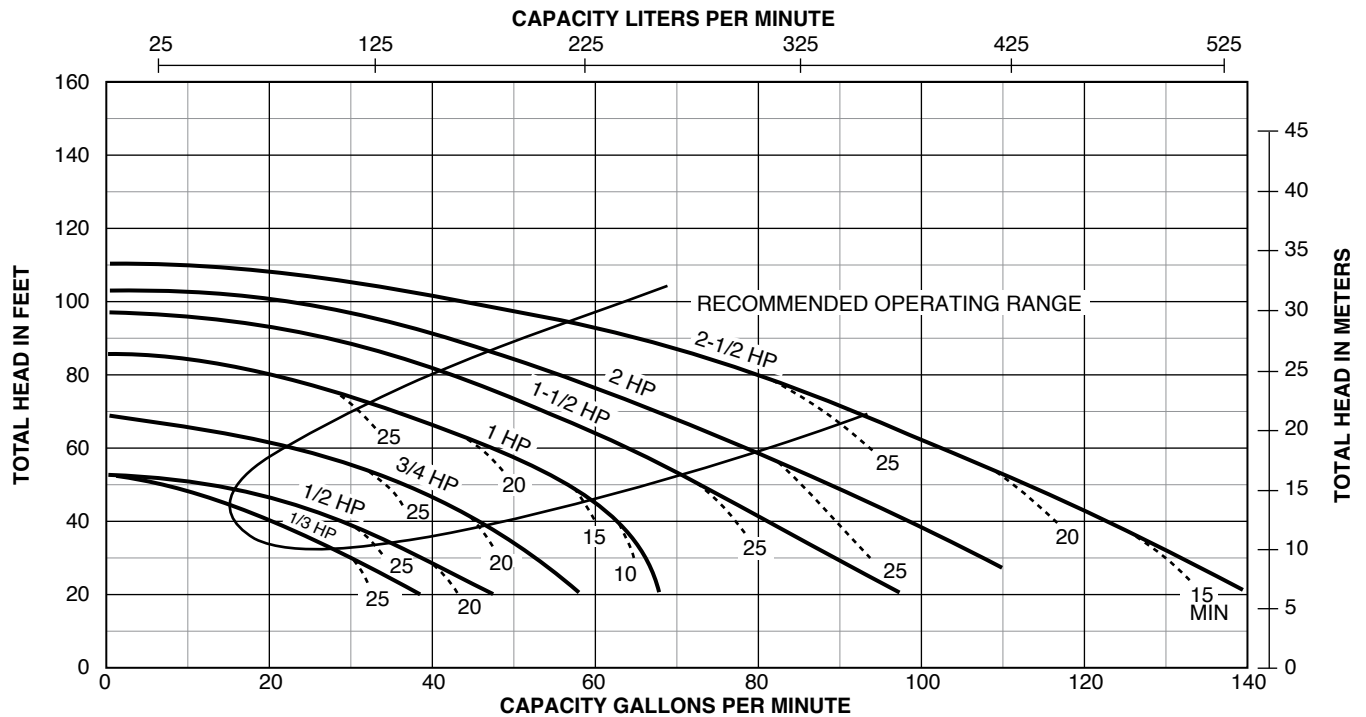

NOTE: Dotted lines indicate performance reduction at high suction lift.

## PUMP PERFORMANCE (Capacity in gallons per minute)

### MEDIUM HEAD

HP	Discharge Pressure		Dynamic Suction Lift				
	PSI	Feet Head	5'	10'	15'	20'	25'
1/3	10	23.1	32	27	18	—	—
	20	46.2	—	—	—	—	—
1/2	10	23.1	40	37	32	27	17
	20	46.2	—	—	—	—	—
3/4	10	23.1	—	50	46	42	32
	20	46.2	37	29	21	—	—
1	20	46.2	54	51	44	40	33
	30	69.3	33	28	18	—	—
1-1/2	20	46.2	71	69	62	57	51
	30	69.3	52	47	34	30	20
2	20	46.2	88	84	78	70	66
	30	69.3	67	60	50	45	40
	40	92.4	25	13	—	—	—
2-1/2	20	46.2	111	106	101	95	90
	30	69.3	90	83	77	70	60
	40	92.4	46	38	20	—	—

Tested and rated in accordance with Water Systems Council Standards.

NOTE: Pumps installed with a Pro-Source® tank require a 100 PSI relief valve. Pumps with a conventional tank require a 75 PSI relief valve. Relief valve must be capable of relieving entire flow of pump at relief pressure.

# J/JB Series

General purpose centrifugal pumps

## OUTLINE DIMENSIONS

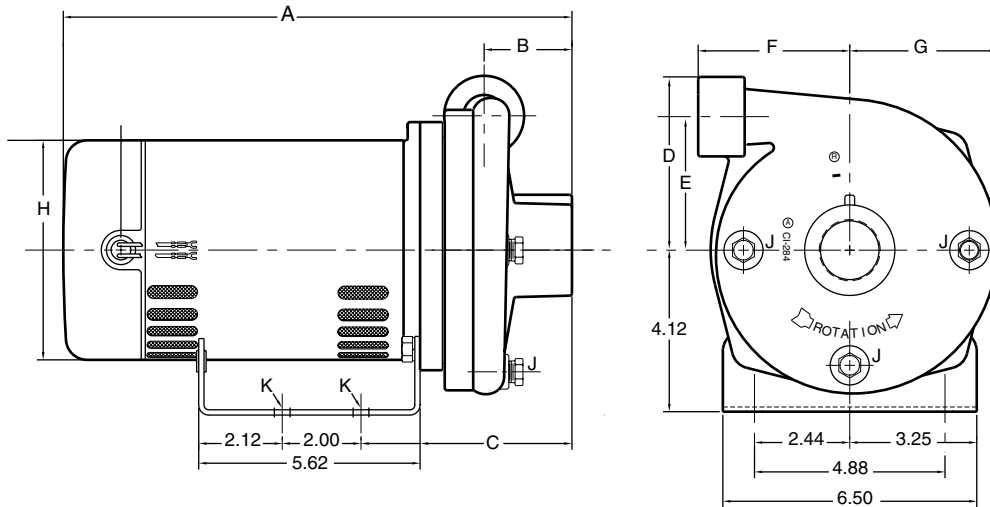

Dimensions (in inches) are for estimating purposes only.

### DIMENSIONS (IN INCHES)

#### HIGH HEAD

HP	NPT Suct.	NPT Disch.	A (1 Phase)	A (3 Phase)	B	C	D	E	F	G	H	NPT J	K
1/3	1-1/4	1	13	13-3/8	2-1/16	5-9/16	4-1/2	3-7/16	3-7/8	3-15/16	5-5/8	1/4	3/8 Dia.
1/2	1-1/4	1	11-21/32	13-3/8	2-1/16	5-9/16	4-1/2	3-7/16	3-7/8	3-15/16	5-5/8	1/4	3/8 Dia.
3/4	1-1/4	1	11-25/32	13-3/8	2-1/16	5-9/16	4-1/2	3-7/16	3-7/8	3-15/16	5-5/8	1/4	3/8 Dia.
1	1-1/4	1	12-25/32	13-7/8	2-1/16	5-9/16	4-1/2	3-7/16	3-7/8	3-15/16	5-5/8	1/4	3/8 Dia.
1-1/2	1-1/4	1	13-39/64	14-3/8	2-1/16	5-9/16	4-1/2	3-7/16	3-7/8	3-15/16	5-5/8	1/4	3/8 Dia.
2	1-1/2	1-1/4	16-3/4	16-15/16	2-13/16	6-5/16	4-27/32	3-13/32	4-5/8	4	6-7/16	1/4	3/8 Dia.
2-1/2	2	1-1/2	17-3/4	17-1/4	2-13/16	6-5/16	4-27/32	3-13/32	4-5/8	4	6-7/16	1/4	3/8 Dia.

#### MEDIUM HEAD

1/3	1-1/4	1	12-9/16	12-15/16	1-7/16	5-1/8	4-7/16	3-1/4	2-1/4	3-1/4	5-5/8	1/4	3/8 Dia.
1/2	1-1/4	1	11-7/32	12-15/16	1-7/16	5-1/8	4-7/16	3-1/4	2-1/4	3-1/4	5-5/8	1/4	3/8 Dia.
3/4	1-1/4	1	11-31/32	12-15/16	1-7/16	5-1/8	4-7/16	3-1/4	2-1/4	3-1/4	5-5/8	1/4	3/8 Dia.
1	1-1/2	1-1/4	12-11/32	13-7/16	1-7/16	5-1/8	4-7/16	3-1/4	2-1/4	3-1/4	5-5/8	1/4	3/8 Dia.
1-1/2	1-1/2	1-1/4	13-25/32	14-9/16	2	5-3/4	4-13/16	3-1/2	4-1/4	3-15/16	5-5/8	1/4	3/8 Dia.
2	1-1/2	1-1/4	16-3/16	16-3/8	2	5-3/4	4-13/16	3-1/2	4-1/4	3-15/16	6-7/16	1/4	3/8 Dia.
2-1/2	2	1-1/2	17-3/16	16-11/16	2	5-3/4	4-13/16	3-1/2	4-1/4	3-15/16	6-7/16	1/4	3/8 Dia.

# Pro-Source<sup>®</sup> Pumper Series

Engine-driven pumps



Lightweight, corrosion-resistant, engineered composite pump construction make this engine-driven pump extremely versatile for applications where electrical power is not available.

Powered by a powerful 6-1/2 HP, PowerPro 4-cycle gasoline engine, rated for continuous-duty, equipped with professional-grade features like an automatic low-oil safety cut, manual throttle, choke and shut-off controls.

Securely mounted within a rugged steel framed rollcage, reinforced with steel cross-members, coated for corrosion resistance, equipped with noise-dampening, non-slip rubber feet.

Suction lift capability of 25 feet.

## APPLICATIONS

Water Transfer and Supply  
 Sprinkler Turf Irrigation  
 Dewatering  
 Fire Protection  
 Agriculture, Light Commercial and Marine

## SPECIFICATIONS

**Body:** Reinforced corrosion-resistant thermoplastic

**Impeller:** Polymer

**Diffuser:** Reinforced corrosion-resistant thermoplastic

**Seals:** Viton mechanical

**O-rings:** Viton

**Check Valve:** Viton

**Rollcage:** Coated steel frame with cross-member and stay-in-place (no-slip) rubber feet

**Engine:** 6-1/2 HP

**Dimensions:** 21"H x 17"D x 21"L

**Fasteners:** 300 grade stainless steel

## FEATURES

Rugged Lightweight Design

Corrosion-Resistant Composite Pump Construction

Chemical-Resistant Viton Seals, O-rings with Stainless Steel Fasteners

Built-in Check Valve

## ACCESSORIES

**Suction Hose Kit:** Built-in 2" NPTF swivel fitting and 2" NPTM fitting for easy hookup; coil-reinforced wall prevents collapse; includes aluminum suction screen to prevent debris from reaching pump

**Discharge Hose Kit:** Built-in 2" NPTF swivel fitting and 2" NPTM fitting for easy hookup; collapsible for easy roll-up and storage; reinforced wall adds durability

## ORDERING INFORMATION

Catalog Number	HP	Description	Pipe Tapping Sizes		Approx. Wt. Lbs./Kg
			Suction	Discharge	
EDP55RV	6-1/2	Engine-driven pump w/rollcage	2" NPT	2" NPT	46/20.9

## ACCESSORIES

Catalog Number	Description	Approx. Wt. Lbs./Kg
FP2735	2" x 15' Suction Hose Kit	15/6.8
FP2731	2" x 25' Discharge Hose Kit	6/2.7



FP2735  
Suction  
Hose Kit



FP2731  
Discharge  
Hose Kit

# Pro-Source® Pumper Series

Engine-driven pumps

## PUMP PERFORMANCE

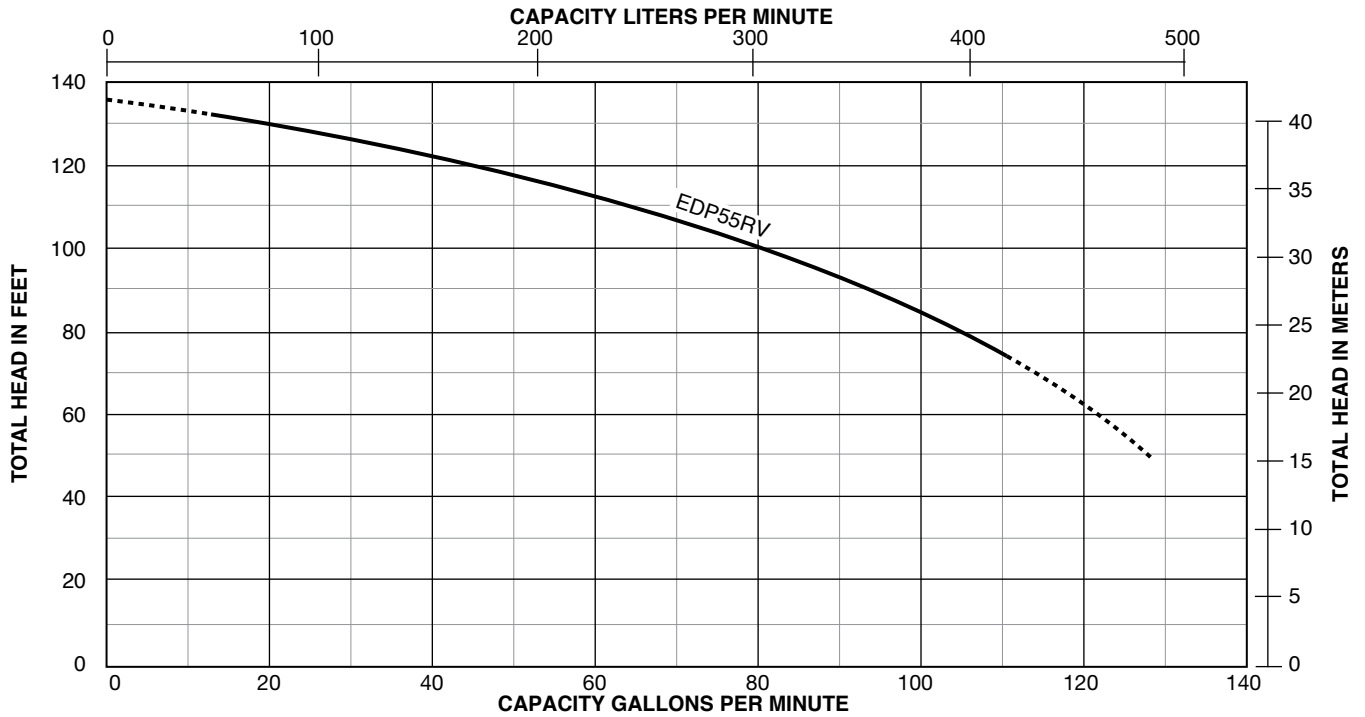

## OUTLINE DIMENSIONS

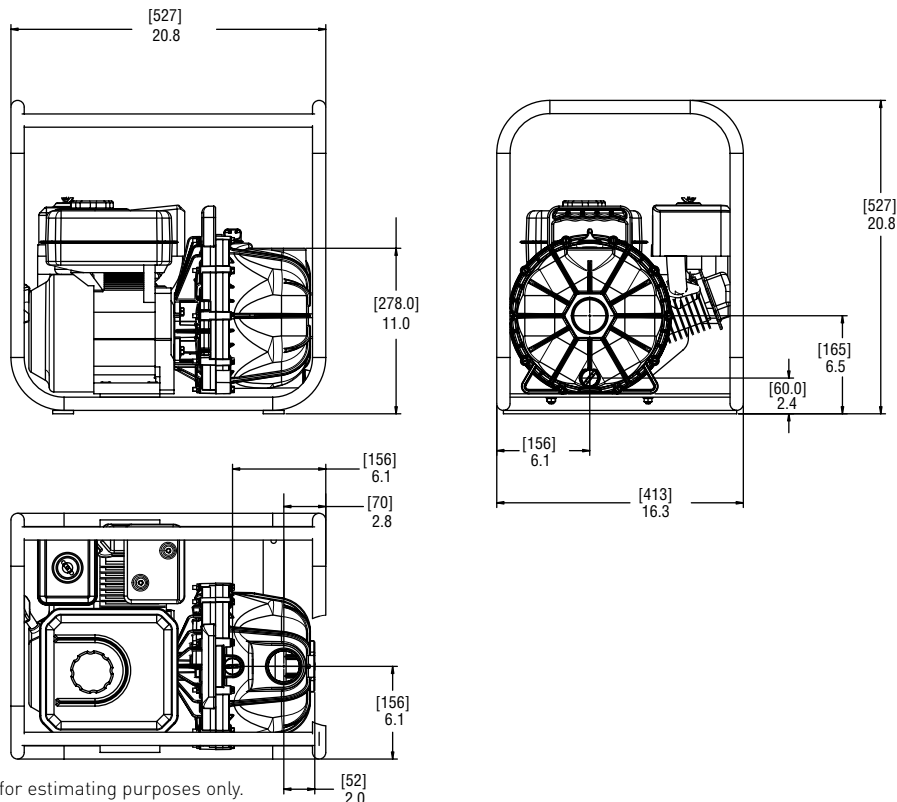

Dimensions (in inches) are for estimating purposes only.

# EDD/EEDD Series

Engine-driven self-priming pumps

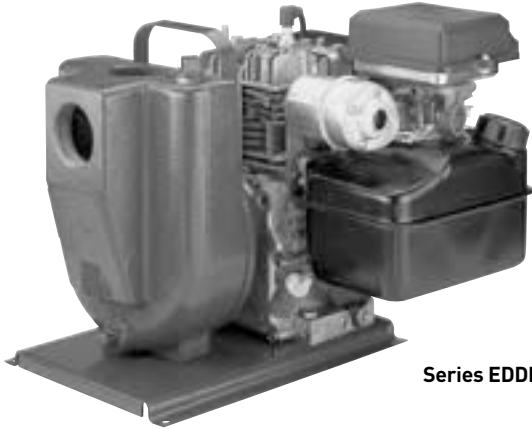

Series EDDH



Series EEDDH

These engine-driven centrifugal pumps can be used where electrical power is not available. Powerful 4-cycle gasoline engines get the job done faster and more efficiently.

Close-coupled EDDH has pump and engine close-coupled on all-steel base...16" long, 14" wide and 13-1/8" high. EDDH features 5/8" diameter, ductile iron threaded shaft extension.

Frame-mounted EEDDH features pump and engine frame-mounted on all-steel base...18-11/16" long, 14" wide and 13-1/8" high. Stub shaft allows easy replacement with other gasoline-powered engines. EEDDH has 3/4" diameter keyed ductile iron shaft extension.

Order Catalog No. EEDD for pump end only, supplied without engine, to be used with 5/8" or 3/4" shaft in gasoline-engine-driven applications. Pump is identical in design to stub-shaft EEDDH.

## SPECIFICATIONS

**Body:** Close-grained cast iron

**Impeller:** Cast iron

**Diffuser:** Cast iron

**Diffuser Ring:** Buna-N

**Stub Shaft (EEDD only):**

416 stainless steel

## ORDERING INFORMATION

Catalog Number	HP	Description	Fuel Tank Size	Pipe Tapping Sizes		Approx. Wt. Lbs.
				Suction	Discharge	
EDDH	3	Gasoline-powered pump	3 Quarts	2"	2"	65
EEDDH	3	Gasoline-powered pump	3 Quarts	2"	2"	70
EEDD	-	Gasoline-powered pump	-	2"	2"	38

Design Series EDDH - Engine-driven without stub shaft

Design Series EEDDH - Engine-driven with stub shaft

Design Series EEDD - Stub shaft pump only

# EDD/EEDD Series

Engine-driven self-priming pumps

## OUTLINE DIMENSIONS: EEDD

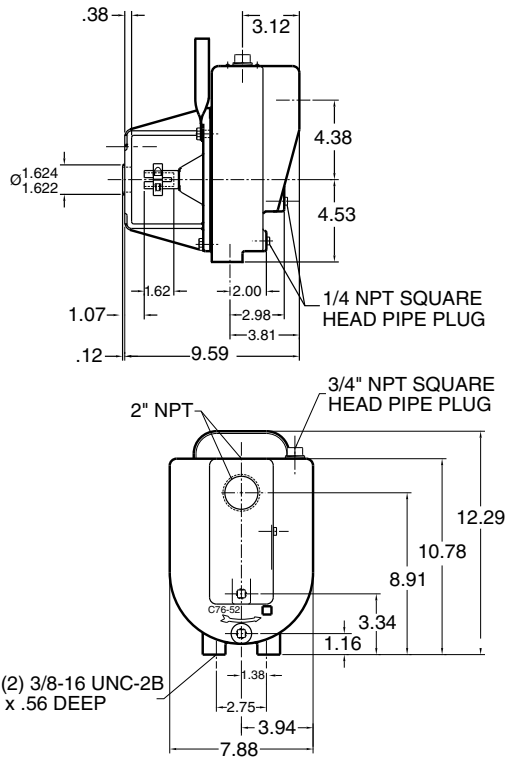

## OUTLINE DIMENSIONS: EEDDH

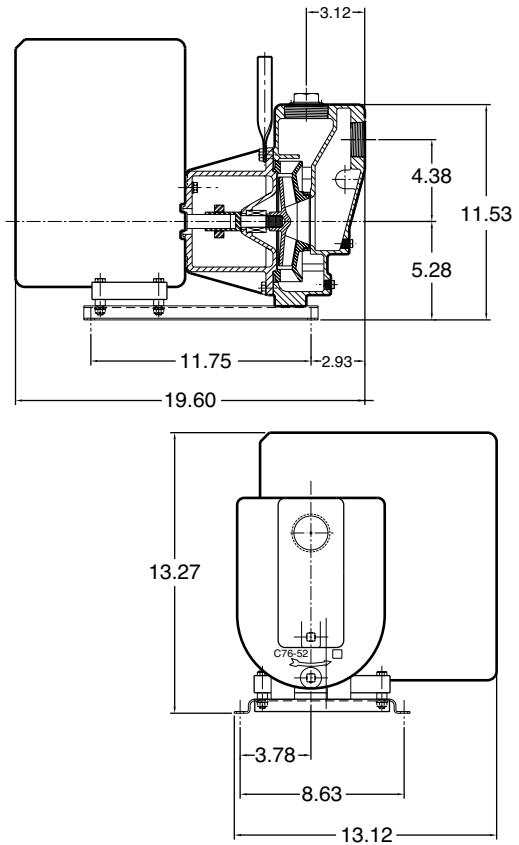

Dimensions (in inches) are for estimating purposes only.

## PUMP PERFORMANCE

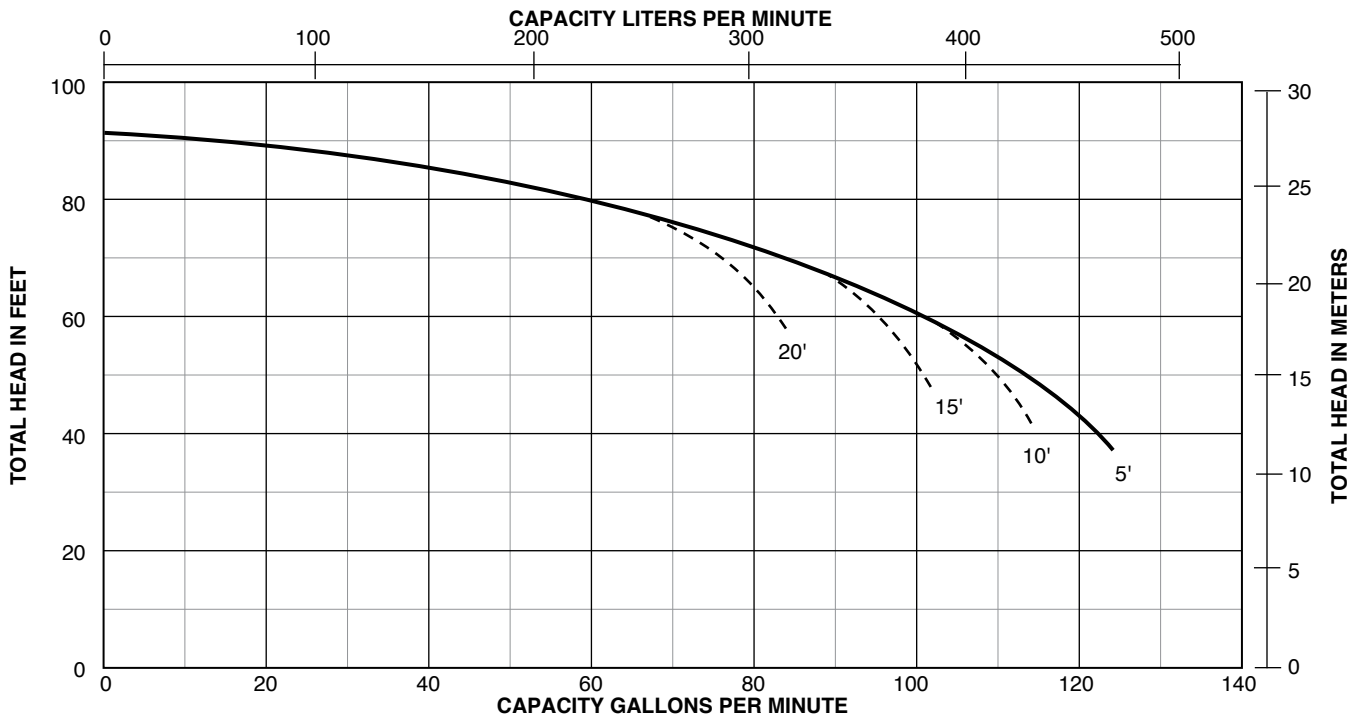

NOTE: Dotted lines indicate performance reduction at high suction lift.

# Water Systems Product Nomenclature

Sta-Rite® Catalog Numbers define products for you.

The following paragraphs describe number assignments and their meanings for 4" submersibles, jets and small centrifugal pumps.

## 4" SUBMERSIBLE PUMP CATALOG NUMBERS

Submersible pump catalog numbers are patterned like this:

### S10P4HS05221

	(1) Brand	(2) GPM	(3) Motor Type Motor Size	(4) Pump Series	(5) HP	(6) Volts	(7) No. of Wires	(8) Phase
example:	S	10	P4	HS	05	2	2	1

**Brand:**  
S - Sta-Rite

**GPM:**  
**Gallons Per Minute**  
Current sizes: 5, 7, 10, 15, 20, 30  
for the 4" Series.

**Type:**  
P4 - Pentek® four inch

**Pump Series:**  
HS: "H" Series Stainless Steel  
JP: "J" Series Plastic  
K: "K" Series Composite  
KS: "KS" Series Stainless Steel

**Volts:**  
1 = 115V  
2 = 230V

**HP: Horsepower**  
Horsepower designation for all Sta-Rite pumps:  
05 = .5 HP  
07 = .75 HP  
10 = 1 HP  
15 = 1.5 HP

**Phase:**  
1 = Single

**No. of Wires:**  
2 = 2-wire  
3 = 3-wire

# Water Systems Product Nomenclature

## JET PUMP CATALOG NUMBERS

Jet pump catalog numbers are patterned like this:

### SNC-L

	(1)	(2)	(3)
	type	HP	dash#

example: SN C -L

**(1) type: PUMP DESIGN SERIES**

**(2) HP: HORSEPOWER**

Horsepower designation for all Sta-Rite Pumps:

B = 1/3 HP      E = 1 HP  
 C = 1/2 HP      F = 1-1/2 HP  
 D = 3/4 HP      G = 2 HP

**(3) dash#: ENGINEERING SERIES NUMBER (dash number)**

Indicates small product improvements.

## STEEL TANK CATALOG NUMBERS

Steel tank catalog numbers are patterned like this:

### PS19T

	(1)	(2)	(3)
	type	size	dash#

example: PS 19T -T02

**(1) type: TANK DESIGN SERIES**

**(2) size: Tank size equivalent to traditional galvanized air-over-water tank**

T = "tall" stand-up type  
 H = "horizontal" pump mount type

**(3) dash#: ENGINEERING SERIES NUMBER (dash number)**

Indicates small product improvements.

## SMALL CENTRIFUGAL PUMP CATALOG NUMBERS

Centrifugal pump catalog numbers are patterned like this:

### DS3HE

	(1)	(2)	(3)	(4)
	type	head	HP	dash#

example: DS3 H E -01

**(1) type: PUMP DESIGN SERIES**

**(2) head: HEAD DESIGN**

H = high head

**(3) HP: HORSEPOWER**

Horsepower designation for all Sta-Rite Pumps:

B = 1/3 HP      G = 2 HP  
 C = 1/2 HP      HG = 2-1/2 HP  
 D = 3/4 HP      H = 3 HP  
 E = 1 HP      J = 5 HP  
 F = 1-1/2 HP

Note that there is no unique letter for a 2-1/2 HP motor. When the head designator is doubled as in "HH" followed by a "G" horsepower code, the motor will be a 2-1/2 HP.

**(4) dash#: ENGINEERING SERIES NUMBER (dash number)**

Indicates small product improvements.

## FIBREWOUND TANKS

Fibrewound tank catalog numbers are patterned like this:

### PSC-35-10

	(1)	(2)	(3)	(4)
	type	size	drawdown	dash#

example: PSC 35 -10 -01

**(1) type: TANK DESIGN SERIES**

**(2) size: Tank vessel capacity in U.S. gallons**

**(3) drawdown: U.S. gallons drawdown with a 30-50 system pressure**

**(4) dash#: ENGINEERING SERIES NUMBER (dash number)**

Indicates small product improvements.

# Sizing Home Water Systems

Pentair has developed the following “Rule of Thumb” formula for sizing home water systems that will be applicable in many instances:

Simply count the fixtures and water outlets in the home. This method bases the approximate pumping capacity on use at the rate of a gallon per minute per fixture, and avoids the possibility of undersizing.

For instance, let us assume you count the following list of fixtures and water outlets in your home:

<b>Kitchen:</b>	Sink/Dishwasher	1
	(count as 1 fixture)	1
<b>Bath:</b>	Lavatory	1
	Tub	1
	Toilet	1
<b>Powder Room:</b>	Lavatory	1
	Toilet	1
<b>Laundry and Utility Room:</b>		
	Automatic washing machine	
	(count as one fixture)	1
	Laundry tubs	1
	Shower	1
	Outdoor faucets	2

**Total fixtures and outlets 12**

Be sure that your pump installer provides a water system that will deliver 12 gallons per minute at the desired pressure.

## Average Water Requirements for General Service Around the Home and Farm

Each person per day, for all purposes	50 gal.
Each horse, dry cow or beef animal per day	12 gal.
Each milking cow per day	35 gal.
Each hog per day	4 gal.
Each sheep per day	2 gal.
Each 100 chickens per day	4 gal.

## Average Amount of Water Required By Various Home and Yard Fixtures

Drinking fountain, continuously flowing, 50 to 100 gal. per day	
Each shower bath	Up to 60 gal.
To fill bathtub	30 gal.
To flush toilet	6 gal.
To fill lavatory	2 gal.
To sprinkle 1/4" of water on each 1000 sq. feet of lawn	160 gal.
Dishwasher – per load	3 gal.
Automatic washer – per load	Up to 50 gal.
Regeneration of domestic water softener	50-100 gal.

## Average Flow Rate Requirements by Various Fixtures

(GPM equals gallons per minute; GPH equals gallons per hour)

Shower	4 to 6 GPM
Bathtub	4 to 8 GPM
Toilet	4 to 5 GPM
Lavatory	1 to 3 GPM
Kitchen sink	2 to 3 GPM
1/2" hose and nozzle	200 GPH
3/4" hose and nozzle	300 GPH
Lawn sprinkler	120 GPH

## Pounds Pressure – Feet of Head

Each pound of pressure developed by a pumping system is equal to 2.31 feet of head (feet of lift). Therefore, 10 pounds of pressure (PSI) will lift water vertically 23.1 feet. The following chart converts pressure to feet of head at various settings from 1 to 100 PSI.

This can be calculated for any setting using the following formula:

$$\text{Pounds per Sq. Inch} = \frac{\text{Head in Feet}}{2.31}$$

$$\text{Head in Feet} = \text{Pounds per Sq. In.} \times 2.31$$

## CONVERSION TABLE

### POUNDS PRESSURE/FEET OF HEAD

Pounds Pressure	Feet of Head
1	2.31
5	11.6
10	23.1
15	34.7
20	46.2
25	57.7
30	69.3
35	80.8
40	92.4
45	103.9
50	115.5
60	138.6
65	150.1
70	161.7
75	173.2
80	184.8
85	196.3
90	207.9
95	219.4
100	231.0

# Pipe Friction Loss Charts

1/2"-1-1/4" I.D.

## LOSS OF HEAD IN FEET DUE TO FRICTION PER 100 FEET OF PIPE

1/2"					3/4"					1"					1-1/4"				
Flow U.S. Gal. Min.	Velocity Plastic ft/sec	Plastic C=140 ID .622"	Steel C=100 ID .622"	Copper C=130 ID .625"	Flow U.S. Gal. Min.	Velocity Plastic ft/sec	Plastic C=140 ID .824"	Steel C=100 ID .824"	Copper C=130 ID .822"	Flow U.S. Gal. Min.	Velocity Plastic ft/sec	Plastic C=140 ID 1.049"	Steel C=100 ID 1.049"	Copper C=130 ID 1.062"	Flow U.S. Gal. Min.	Velocity Plastic ft/sec	Plastic C=140 ID 1.380"	Steel C=100 ID 1.380"	Copper C=130 ID 1.368"
0.5	0.5	0.314	0.582	0.35	1.5	0.9	0.61	1.13	0.7	2	0.74	0.322	0.595	0.345	4	0.9	0.304	0.564	0.364
1	1.1	1.14	2.1	1.26	2	1.2	1.04	1.93	1.21	3	1.1	0.68	1.26	0.732	5	1.1	0.46	0.853	0.545
1.5	1.6	2.38	4.44	2.67	2.5	1.5	1.57	2.91	1.82	4	1.5	1.15	2.14	1.24	6	1.3	0.649	1.2	0.765
2	2.1	4.1	7.57	4.56	3	1.8	2.21	4.08	2.56	5	1.9	1.75	3.42	1.88	7	1.5	0.86	1.59	1.02
2.5	2.6	6.15	11.4	6.88	3.5	2.1	2.93	5.42	3.4	6	2.2	2.45	4.54	2.63	8	1.7	1.1	2.04	1.31
3	3.2	8.65	16	9.66	4	2.4	3.74	6.94	4.36	8	3.0	4.16	7.73	4.5	10	2.1	1.67	3.08	1.98
3.5	3.7	11.5	21.3	12.9	4.5	2.7	4.66	8.63	5.4	10	3.7	6.31	11.7	6.77	12	2.6	2.33	4.31	2.75
4	4.2	14.8	27.3	16.4	5	3.0	5.66	10.5	6.57	12	4.5	8.85	16.4	9.47	14	3.0	3.1	5.73	3.64
4.5	4.8	18.3	33.9	20.4	6	3.6	7.95	14.7	9.22	14	5.2	11.8	21.8	12.6	16	3.4	3.96	7.34	4.68
5	5.3	22.2	41.2	24.8	7	4.2	10.6	19.6	12.2	16	5.9	15.1	27.9	16.2	18	3.9	4.93	9.13	5.81
5.5	5.8	26.6	49.2	29.5	8	4.8	13.5	25	15.7	18	6.7	18.7	34.7	20.1	20	4.3	6	11.1	7.1
6	6.3	31.2	57.8	34.8	9	5.4	16.8	31.1	19.5	20	7.4	22.8	42.1	24.4	25	5.4	9.06	16.8	10.7
6.5	6.9	36.2	67	40.2	10	6.0	20.4	37.8	23.7	22	8.2	27.1	50.2	28.8	30	6.4	12.7	23.5	15
7	7.4	41.5	76.8	46.1	11	6.6	24.4	45.1	28.2	24	8.9	31.9	59	34	35	7.5	16.9	31.2	20
7.5	7.9	47.2	87.3	52.5	12	7.2	28.6	53	33.2	26	9.7	36.9	68.4	39.7	40	8.6	21.6	40	25.6
8	8.4	53	98.3	59.4	13	7.8	33.2	61.5	38.5	28	10.4	42.5	78.5	45.5	50	10.7	32.6	60.4	38.7
8.5	9.0	59.5	110	66	14	8.4	38	70.5	44.2	30	11.1	48.1	89.2	51.6	60	12.9	45.6	84.7	54.1
9	9.5	66	122	73.5	16	9.6	48.6	90.2	56.6	35	13.0	64.3	119	68.7	70	15.0	61.5	114	72.2
9.5	10.0	73	135	81	18	10.8	60.5	112	70.4	40	14.8	82	152	88	80	17.2	77.9	144	92.4
10	10.6	80.5	149	89.4	20	12.0	73.5	136	83.5	45	16.7	102	189	109	90	19.3	96.6	179	115

NOTE: Recommended velocity is 5 FPS (feet per second) with a maximum of 7 FPS.

## FRICTION LOSSES THROUGH FITTINGS IN TERMS OF EQUIVALENT LENGTHS OF PIPE

Type Fitting and Application	Pipe and Fitting Material (Note 1)	Equivalent Length of Pipe – Nominal Size Fitting and Pipe						
		1/2	3/4	1	1-1/4	1-1/2	2	2-1/2
Threaded Adapter Plastic or Copper to Thread	Copper	1	1	1	1	1	1	1
	Plastic	3	3	3	3	3	3	3
90° Standard Elbow	Steel	2	3	3	4	4	5	6
	Copper	2	3	3	4	4	5	6
	Plastic	4	5	6	7	8	9	10
Insert Coupling	Plastic	3	3	3	3	3	3	3
Standard Tee	Steel	4	5	6	8	9	11	14
	Copper	4	5	6	8	9	11	14
	Plastic	7	8	9	12	13	17	20
Gate Valve	Note (2)	2	3	4	5	6	7	8

Note (1) Loss Figures are based on equivalent lengths of indicated pipe material.

Note (2) Loss Figures for screwed valves are based on equivalent lengths of steel pipe.

# Pipe Friction Loss Charts

1-1/2"-2-1/2" I.D.

## LOSS OF HEAD IN FEET DUE TO FRICTION PER 100 FEET OF PIPE

1-1/2"					2"					2-1/2"				
Flow U.S. Gal. Min.	Velocity Plastic ft/sec	Plastic C=140 ID 1.61"	Steel C=100 ID 1.61"	Copper C=130 ID 1.60"	Flow U.S. Gal. Min.	Velocity Plastic ft/sec	Plastic C=140 ID 2.067"	Steel C=100 ID 2.067"	Copper C=130 ID 2.062"	Flow U.S. Gal. Min.	Velocity Plastic ft/sec	Plastic C=140 ID 2.469"	Steel C=100 ID 2.469"	Copper C=130 ID 2.50"
4	0.6	0.144	0.267	0.165	10	1.0	0.233	0.431	0.268	20	1.3	0.353	0.654	0.375
6	0.9	0.305	0.565	0.358	15	1.4	0.495	0.916	0.569	30	2.0	0.75	1.39	0.792
8	1.3	0.52	0.962	0.611	20	1.9	0.839	1.55	0.962	40	2.7	1.27	2.36	1.35
10	1.6	0.785	1.45	0.923	25	2.4	1.27	2.35	1.45	50	3.4	1.92	3.56	2.04
12	1.9	1.1	2.04	1.29	30	2.9	1.78	3.29	2.03	60	4.0	2.69	4.99	2.86
14	2.2	1.46	2.71	1.71	35	3.3	2.36	4.37	2.71	70	4.7	3.58	6.64	3.82
16	2.5	1.87	3.47	2.2	40	3.8	3.03	5.6	3.47	80	5.4	4.59	8.5	4.88
18	2.8	2.33	4.31	2.75	45	4.3	3.76	6.96	4.31	90	6.0	5.72	10.6	6.06
20	3.2	2.83	5.24	3.31	50	4.8	4.57	8.46	5.24	100	6.7	6.9	12.8	7.37
25	3.9	4.26	7.9	5	55	5.3	5.46	10.1	6.22	110	7.4	8.25	15.3	8.8
30	4.7	6	11.1	7	60	5.7	6.44	11.9	7.34	120	8.0	9.71	18	10.3
35	5.5	7.94	14.7	9.35	70	6.7	8.53	15.8	9.78	130	8.7	11.3	20.9	12
40	6.3	10.2	18.9	12	80	7.6	10.9	20.2	12.5	140	9.4	12.9	23.9	13.7
45	7.1	12.63	23.4	14.9	90	8.6	13.6	25.1	15.6	150	10.1	14.7	27.3	15.6
50	7.9	15.4	28.5	18.1	100	9.6	16.5	30.5	18.9	160	10.7	16.6	30.7	17.6
55	8.7	18.35	34	21.5	110	10.5	19.7	36.4	22.5	170	11.4	18.5	34.3	19.7
60	9.5	21.6	40	25.3	120	11.5	23.1	42.7	26.6	180	12.1	20.6	38.1	21.9
65	10.2	25.1	46.4	29	130	12.4	26.8	49.6	30.7	190	12.7	22.7	42.1	24.2
70	11.0	28.7	53.2	33.8	140	13.4	30.6	56.9	35.2	200	13.4	25	46.3	26.6
75	11.8	32.6	60.4	38	150	14.3	35	64.7	40.1	220	14.7	29.8	55.3	31.8
80	12.6	36.8	68.1	43.1	160	15.3	39.3	72.8	45.1	240	16.1	35.8	66.4	37.4
85	13.4	41.2	76.2	47.6	170	16.3	44	81.4	50.5	260	17.4	41.6	75.3	43.3
90	14.2	45.7	84.7	53.6	180	17.2	48.9	90.5	56.1	280	18.8	46.6	86.3	49.4
95	15.0	50.5	93.6	58.8	190	18.2	54	100	62	300	20.1	52.9	98.1	56.8
100	15.8	56.6	103	65.1	200	19.1	59.4	110	68					

NOTE: Recommended velocity is 5 FPS (feet per second) with a maximum of 7 FPS.

Note (1) Loss Figures are based on equivalent lengths of indicated pipe material

Note (2) Loss Figures for screwed valves based on equivalent lengths of steel pipe.

# Cable Selection

Stainless steel, 4" submersible motors

## TWO DIFFERENT CABLE SIZES CAN BE USED

The example below is for reference. Depending on the installation, any number of combinations may be used, as long as the total percentage length of the two cables used does not exceed 100%. This is to ensure that adequate voltage will be supplied to the motor.

**EXAMPLE:**  
1 HP,  
230 Volt, 3W,  
1 PH Motor

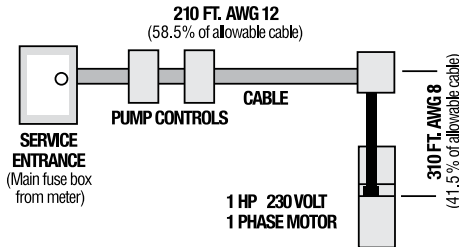

In a replacement installation, the well already has 210 feet of buried #12 cable between the service entrance and the well head. The question is: What size cable is required in the well with a 1 HP, 230 Volt, 1 PH, 3W motor setting at 310 feet?

1. According to the table, #12 cable is large enough for the 1 HP motor so the percent of the maximum allowable cable used by the 210-foot run is  $210 \div 359 = 58.5\%$ , since 359 feet is the total allowable.
2. With 58.5% of the total allowable cable already used between the service entrance and the well head, only 41.5% is left for the well. Therefore, the 310 feet needed in the well can only utilize 41.5% of the total feet allowed in the table.
3. From the table, 41.5% of the 573 feet for #10 cable equals only 238 feet, so a larger size is needed. For #8, 41.5% of 908 feet = 377 feet. As a result, #8 can be used for the 310 feet in the well.

**CAUTION** Use of wire size smaller than listed will void warranty.

## MOTOR LEAD LENGTHS: PENTEK® 2-WIRE MOTORS

60 HZ MOTOR RATING		60C AND 75C INSULATION - AWG COPPER WIRE SIZE												
VOLTS	HP	14	12	10	8	6	4	3	2	1	1/0	2/0	3/0	4/0
115	1/2	107	171	273	432	672	1071	1346	1700	2142	2703	3411	4305	5424
230	1/2	457	726	1158	1835	2855	4551	5721	7225	9102	11489			
	3/4	342	545	869	1376	2141	3413	4291	5419	6826	8617	10871		
	1	267	425	678	1074	1671	2664	3349	4229	5328	6725	8485	10711	
	1-1/2	209	332	530	839	1305	2080	2615	3303	4161	5252	6626	8365	

## MOTOR LEAD LENGTHS: PENTEK 3-WIRE PSC MOTORS

### CSIR CONTROL BOXES

60 HZ MOTOR RATING		60C AND 75C INSULATION - AWG COPPER WIRE SIZE												
VOLTS	HP	14	12	10	8	6	4	3	2	1	1/0	2/0	3/0	4/0
115	1/2	94	150	240	380	591	942	1184	1495	1883	2377	2999	3786	4770
230	1/2	348	553	883	1398	2175	3467	4359	5505	6935	8753			
	3/4	277	441	704	1115	1734	2765	3476	4390	5530	6981	8807		
	1	231	367	585	927	1442	2299	2891	3651	4599	5805	7324		

### CSCR CONTROL BOXES

60 HZ MOTOR RATING		60C AND 75C INSULATION - AWG COPPER WIRE SIZE												
VOLTS	HP	14	12	10	8	6	4	3	2	1	1/0	2/0	3/0	4/0
230	1/2	438	697	1112	1761	2740	4369	5492	6936	8738	11029			
	3/4	359	571	912	1444	2246	3581	4502	5685	7162	9040	11406		
	1	296	471	751	1190	1852	2952	3711	4686	5904	7452	9402		
	1-1/2	199	317	505	801	1246	1986	2496	3153	3972	5013	6325		
	2	180	286	456	722	1123	1790	2251	2843	3581	4520	5703		
	3	133	211	337	534	830	1324	1664	2102	2648	3342	4217	5323	
	5			206	326	507	809	1017	1284	1618	2042	2577	3253	

All lengths in feet.

NOTE: Based on service factor amps, 30C ambient and 5% voltage drop.

(1) This table is based on copper wire. If aluminum wire is used it must be two sizes larger.

Example: When the table calls for #12 copper wire you would use #10 aluminum wire.

(2) Cables #14 to 4/0 are AWG sizes.

# Cable Selection

Stainless steel, 4" submersible motors

## MOTOR LEAD LENGTHS: PENTEK® 3-PHASE MOTORS

60 HZ MOTOR RATING		60C AND 75C INSULATION - AWG COPPER WIRE SIZE												
VOLTS	HP	14	12	10	8	6	4	3	2	1	1/0	2/0	3/0	4/0
200	0.5	629	1000	1595	2526	3931								
	3/4	468	745	1188	1881	2927								
	1	386	614	979	1551	2414	3848	4837						
	1.5	290	461	735	1163	1810	2886	3628						
	2	237	376	600	951	1479	2358	2965	3744	4717	5954			
	3	183	292	465	737	1147	1828	2298	2902	3656	4614			
	5	109	173	276	438	681	1086	1365	1724	2172	2741	3458	4366	5500
7.5	73	117	186	295	459	731	919	1161	1462	1846	2329	2940	3704	
230	0.5	844	1342	2140	3389	5274	8408	10570						
	0.75	633	1006	1605	2542	3956	6306	7927	10011					
	1	516	821	1310	2075	3229	5148	6471	8172					
	1.5	383	610	973	1541	2397	3822	4804	6067	7643	9648			
	2	316	503	803	1271	1978	3153	3964	5006	6306	7960	10042		
	3	251	399	636	1007	1567	2497	3140	3965	4995	6305	7954	10042	12651
	5			367	581	904	1441	1812	2288	2883	3639	4591	5795	7301
7.5				385	599	955	1201	1517	1911	2412	3043	3842	4840	
460	0.5	3374	5367	8561										
	0.75	2531	4025	6420	10168									
	1	2024	3220	5136	8135									
	1.5	1489	2368	3777	5981									
	2	1234	1964	3132	4960	7718								
	3	955	1519	2423	3837	5971								
	5	595	947	1511	2393	3723	5935							
	7.5	375	596	951	1506	2344	3737	4698	5933	7474				
	10	294	468	747	1182	1840	2933	3687	4656	5866				
575	1.5	2433	3870	6173										
	2	1917	3049	4864	7703									
	3	1543	2454	3915	6200									
	5	832	1324	2112	3345	5205								
	7.5	633	1006	1605	2542	3956								

All lengths in feet.

NOTE: Based on service factor amps, 30C ambient and 5% voltage drop.

- (1) This table is based on copper wire. If aluminum wire is used it must be two sizes larger. Example: When the table calls for #12 copper wire you would use #10 aluminum wire.
- (2) The portion of the total cable that is between the service entrance and a 3-phase motor starter should not exceed 25% of the total maximum length to assure reliable starter operation.
- (3) Cables #14 to 4/0 are AWG sizes.



## LIMITED WARRANTY

STA-RITE® warrants to the original consumer purchaser (“Purchaser” or “You”) of the products listed below, that they will be free from defects in material and workmanship for the Warranty Period shown below.

PRODUCT	WARRANTY PERIOD
<b>Water Systems Products:</b> jet pumps, small centrifugal pumps, submersible pumps, controls and related accessories	whichever occurs first: 12 months from date of original installation, or 18 months from date of manufacture
<b>Pro-Source™ Composite Tanks</b>	5 years from date of original installation
<b>Pro-Source Steel Pressure Tanks</b>	5 years from date of original installation
<b>Pro-Source Epoxy-Lined Tanks</b>	3 years from date of original installation
<b>Sump/Sewage/Effluent Products</b>	12 months from date of original installation, or 18 months from date of manufacture

Our warranty will not apply to any product that, in our sole judgement, has been subject to negligence, misapplication, improper installation, or improper maintenance. Without limiting the foregoing, operating a three phase motor with single phase power through a phase converter will void the warranty. Note also that three phase motors must be protected by three-leg, ambient compensated, extra-quick trip overload relays of the recommended size or the warranty is void.

Your only remedy, and STA-RITE’s only duty, is that STA-RITE repair or replace defective products (at STA-RITE’s choice). You must pay all labor and shipping charges associated with this warranty and must request warranty service through the installing dealer as soon as a problem is discovered. No request for service will be accepted if received after the Warranty Period has expired. This warranty is not transferable.

STA-RITE SHALL NOT BE LIABLE FOR ANY CONSEQUENTIAL, INCIDENTAL, OR CONTINGENT DAMAGES WHATSOEVER.

THE FOREGOING WARRANTIES ARE EXCLUSIVE AND IN LIEU OF ALL OTHER EXPRESS AND IMPLIED WARRANTIES, INCLUDING BUT NOT LIMITED TO THE IMPLIED WARRANTIES OF MERCHANTABILITY AND FITNESS FOR A PARTICULAR PURPOSE. THE FOREGOING WARRANTIES SHALL NOT EXTEND BEYOND THE DURATION EXPRESSLY PROVIDED HEREIN.

Some states do not allow the exclusion or limitation of incidental or consequential damages or limitations on the duration of an implied warranty, so the above limitations or exclusions may not apply to You. This warranty gives You specific legal rights and You may also have other rights which vary from state to state.

This warranty supersedes and replaces all previous warranty publications.

**Retain original receipt for your records**



293 WRIGHT STREET, DELAVAN, WI 53115 [WWW.STA-RITE.COM](http://WWW.STA-RITE.COM)  
PH: 888-782-7483 ORDERS FAX: 800-426-9446

490 PINEBUSH ROAD, UNIT 4, CAMBRIDGE, ONTARIO N1T 0A5  
PH: 800-363-7867 ORDERS FAX: 888-606-5484

Because we are continuously improving our products and services, Pentair reserves the right to change specifications without prior notice.