

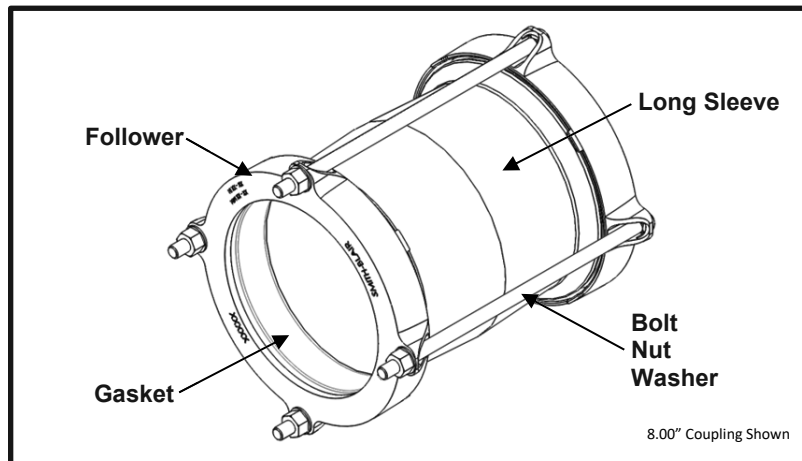

Smith-Blair
a xylem brand

SPECIFICATION

QUANTUM® WIDE RANGE CAST COUPLING – LONG SLEEVE MODEL 462



APPLICATIONS

- **Typical Uses**
 - Joining plain-end pipe of different outside diameters with same nominal size
 - Replace split or excessively damaged pipe
- **Standard Pipe Size(s)**
 - 4" to 12" nominal
- **Type of Pipe**
 - Carbon Steel, Stainless Steel, Ductile Iron, Asbestos Cement, PVC, HDPE
(see notes for HDPE applications)
- **Working Pressure**
 - 250 psi

MATERIALS

- **Follower**
 - Cast using Ductile Iron 65-45-12 per ASTM A536
 - Flexi-Coat® fusion bonded epoxy finish
 - Permanently marked with part number and pipe size range for proper selection
 - Integral bolt head pocket for one wrench installation
 - Designed to provide up to 1.65" of range with a single follower
 - Tabs cast in follower to center and concentrate sealing force uniformly over gasket
- **Sleeve**
 - Cast using Ductile Iron 65-45-12 or 80-55-06 per ASTM A536
 - Flexi-Coat® fusion bonded epoxy finish
 - Single sleeve design for each nominal pipe size reducing inventory
 - Longer body allows for increased size flexibility in pipe repairing and gap separation
- **Gasket**
 - Nitrile (Buna-N) per ASTM D2000
 - Compounded to resist water, oil, natural gas, acids, alkalis, most (aliphatic) hydrocarbon fluids, and many other chemicals
 - Temperature range: -20°F to +180°F
 - Leading edge of gasket has molded in ribs for maximum sealing against sleeve
 - Permanently marked with part number and pipe size range for proper selection



Smith-Blair
a xylem brand

SPECIFICATION

QUANTUM® WIDE RANGE CAST COUPLING – LONG SLEEVE MODEL 462

- **Bolts**
 - HSLA Steel per AWWA C111/A21.11
 - Epoxy coated threads to prevent galling
 - 5/8”-11UNC x 17.00” long, Oval Neck Track Head
 - Rolled threads for improved physical characteristics, greater thread accuracy, and smooth surface finish
- **Nut**
 - HSLA Steel per AWWA C111/A21.11
 - Fluoropolymer coated to prevent galling
 - 5/8”-11UNC, Heavy Hex Semi-Finished
- **Washer**
 - Carbon Steel per ASTM F844
 - Fe/Zn coated per ASTM F1941-10
 - 5/8” Type A Plain
 - Utilized to preserve corrosion resistance of epoxy coated surfaces and increase bearing surface

LISTINGS

- Certified to NSF/ANSI 61 and NSF/ANSI 372
- Meets applicable portions of AWWA C219
- Flexi-Coat® Fusion Bonded Epoxy Coating meets requirements of AWWA C213

OPTIONS

- Type 304 Stainless Steel hardware with fluoropolymer coated nuts to prevent galling
- Type 316 Stainless Steel hardware with fluoropolymer coated nuts to prevent galling
- Alternative gasket material (e.g. Viton, EPDM, etc.)
- Protected gasket (brass spring molded into leading edge)
- Anode connector
- Insulating boot(s)

NOTES

- Pipe stiffeners **are required** when this product is used on HDPE
- Xylem, Smith-Blair, SB stylized, Flexi-Coat, Top Bolt and Quantum are registered trademarks of Xylem, Inc., or one of its subsidiaries.
- These product specifications were correct at the time of publication and are subject to change without notice
- See the Smith-Blair website for part numbers and ordering information
- See the Smith-Blair website for warranty information
- See the Smith-Blair website for corrosion notice



THIS PRODUCT DOES NOT RESTRAIN PIPE MOVEMENT. Proper anchoring is required to prevent pipe pull out. Failure to anchor or improper anchoring can result in dangerous pipe content escape, property damage, serious injury, and/or death. Read the product installation instructions prior to installing this product.



Smith-Blair
a xylem brand

SPECIFICATION

QUANTUM® WIDE RANGE CAST COUPLING – LONG SLEEVE MODEL 462

Recommended Pipe to Pipe Centerline Gaps

Sleeve Length	Optimum Gaps		Maximum Gap
	Straight Run	Deflected Joints	
12"	1"	2-3/4"	6"

Pipe gap to be centered in coupling sleeve.

Total Maximum Allowable Axial Pipe Movement per Coupling

Coupling Size	Allowable Movement
4" to 10"	1/4"
12"	3/8"

Pipe End Tolerances

Nominal Pipe Size	Minus Tolerance	Plus Tolerance
4" to 12"	-0.06	+0.06

Maximum Angular Deflection per Coupling 3° (Pipe to Pipe) 1-1/2° (Pipe to Sleeve)

30 Globe Ave, Texarkana, AR 71854
Ph: 870-773-5127 • Fax: 870-773-5212
Toll-Free Numbers: Ph: 800-643-9705 • Fax: 800-648-6792

