



Smith-Blair
a xylem brand

SPECIFICATION

FULL CIRCLE® REDI-CLAMP®

MODEL 244

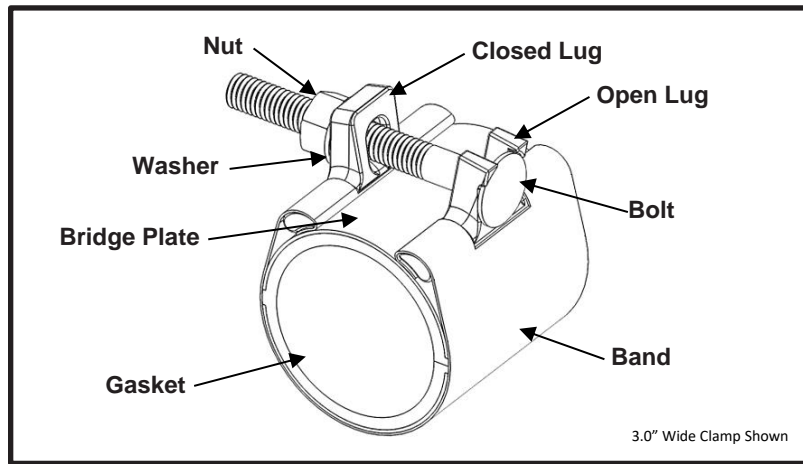

APPLICATIONS

- **Typical Uses**
 - Repair leaks due to complete breaks, splits, or holes
 - Joining pipes of the same diameter
 - Examples:

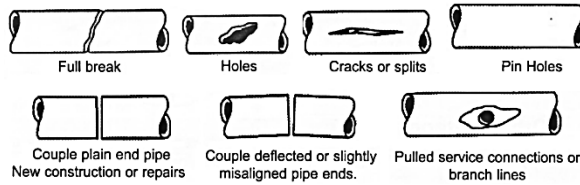

- **Standard Pipe Sizes**
 - 0.5” to 2” nominal
- **Standard Widths**
 - 3.0”, 6.0”, 12.0”
- **Type of Pipe**
 - Carbon Steel, Ductile Iron, Stainless Steel, PVC, Copper
- **Working Pressure**
 - Up to 150 psi depending on type of pipe, type of repair, pipe diameter, service conditions, and installation workmanship

MATERIALS

- **Band**
 - Type 304 Stainless Steel per ASTM A240
 - Band Thickness: 24 gauge
 - Formed to pipe O.D. and secured to lug body
- **Lug**
 - Cast using Ductile Iron 65-45-12 per ASTM A536
 - Flexi-Coat® fusion bonded epoxy finish
 - Designed for drop in replaceable bolts
 - One open loop lug and one closed loop lug. The bolts do not have to be removed to install clamp preventing lost hardware
 - Precision cast with contoured surface to equalize clamping pressures around the pipe



Smith-Blair
a xylem brand

SPECIFICATION

FULL CIRCLE[®] REDI-CLAMP[®]

MODEL 244

- **Gasket**
 - Nitrile (Buna-N) per ASTM D2000
 - Gasket Thickness: 0.25"
 - Compounded to resist water, oil, natural gas, acids, alkalies, most (aliphatic) hydrocarbon fluids, and many other chemicals
 - Temperature range: -20°F to +180°F
 - Full 360° smooth face gasket provides maximum pipe support, reinforcement, and sealing pressure
- **Bridge Plate**
 - 18-8 quarter-hard Type 304 Stainless Steel per ASTM A240
 - Two plates recessed flush and bonded into gasket
 - Preformed for uniform distribution of gasket pressure over the entire pipe circumference
- **Bolt**
 - Carbon Steel SAE J429 GR5
 - Fe/Zn coated per ASTM F1941-10
 - Size: 0.5" – 1.5" nominal pipe size = 3/8"-16UNC x 3.00" long, Round Head Square Neck
2.0" nominal pipe size = 7/16"-14UNC x 4.00" long, Round Head Square Neck
 - Rolled threads for improved physical characteristics, greater thread accuracy, and smooth surface finish
 - Drop in replaceable bolts
- **Nut**
 - Carbon Steel per ASTM A307
 - Fe/Zn coated per ASTM F1941-10
 - Size: 0.5" – 1.5" nominal pipe size = 3/8"-16UNC Heavy Hex
2.0" nominal pipe size = 7/16"-14UNC Heavy Hex
- **Washer**
 - Carbon Steel per ASTM A108
 - Fe/Zn coated per ASTM F1941-10
 - Size: 7/16" Type A Plain

LISTINGS/STANDARDS

- Certified to NSF/ANSI 61 and NSF/ANSI 372
- Flexi-Coat[®] Fusion-Bonded Epoxy Coating meets requirements of AWWA C213

OPTIONS

- Type 316 Stainless Steel band
- Type 304 Stainless Steel hardware with fluoropolymer coated nuts to prevent galling
- Type 316 Stainless Steel hardware with fluoropolymer coated nuts to prevent galling
- Alternative gasket material (e.g. Viton, EPDM, etc.)



Smith-Blair
a xylem brand

SPECIFICATION

FULL CIRCLE[®] REDI-CLAMP[®]

MODEL 244

NOTES

- Pipe stiffeners **are required** when this product is used for joining thin wall PVC pipe
- Clamp may be used for most water and gas applications with the exception of gas plastic pipe repair. It is suitable for restoring shape and marking crimped polyethylene gas service lines.
- Full Circle[®] and Redi-Clamp[®] are registered trademarks of Smith-Blair
- These product specifications were correct at the time of publication and are subject to change without notice
- See the Smith-Blair website for part numbers and ordering information
- See the Smith-Blair website for warranty information
- See the Smith-Blair website for corrosion notice

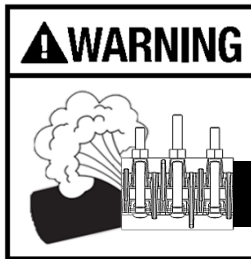

THIS PRODUCT DOES NOT RESTRAIN PIPE MOVEMENT. Proper anchoring is required to prevent pipe pull out. Failure to anchor or improper anchoring can result in dangerous pipe content escape, property damage, serious injury, and/or death. Read the product installation instructions prior to installing this product.

30 Globe Ave, Texarkana, AR 71854
Ph: 870-773-5127 • Fax: 870-773-5212
Toll-Free Numbers: Ph: 800-643-9705 • Fax: 800-648-6792

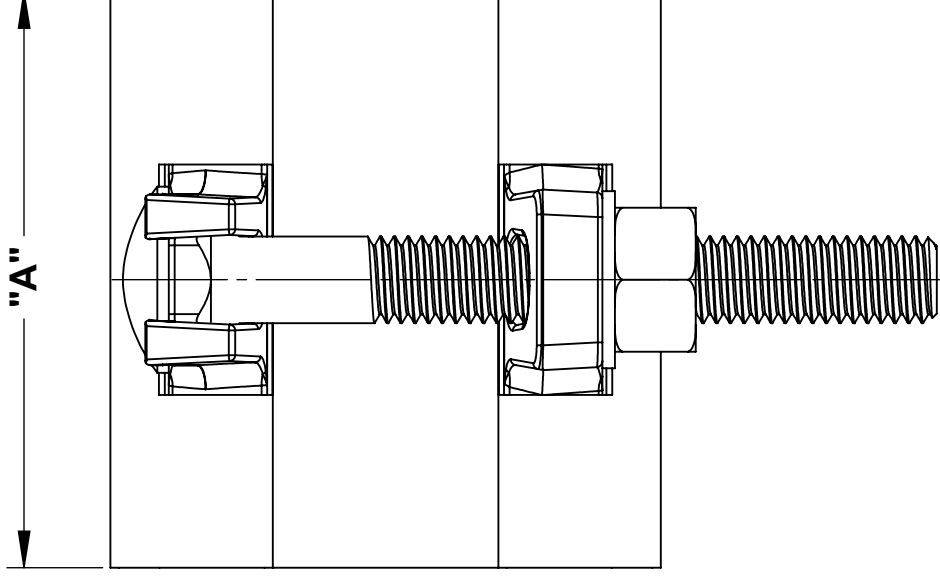
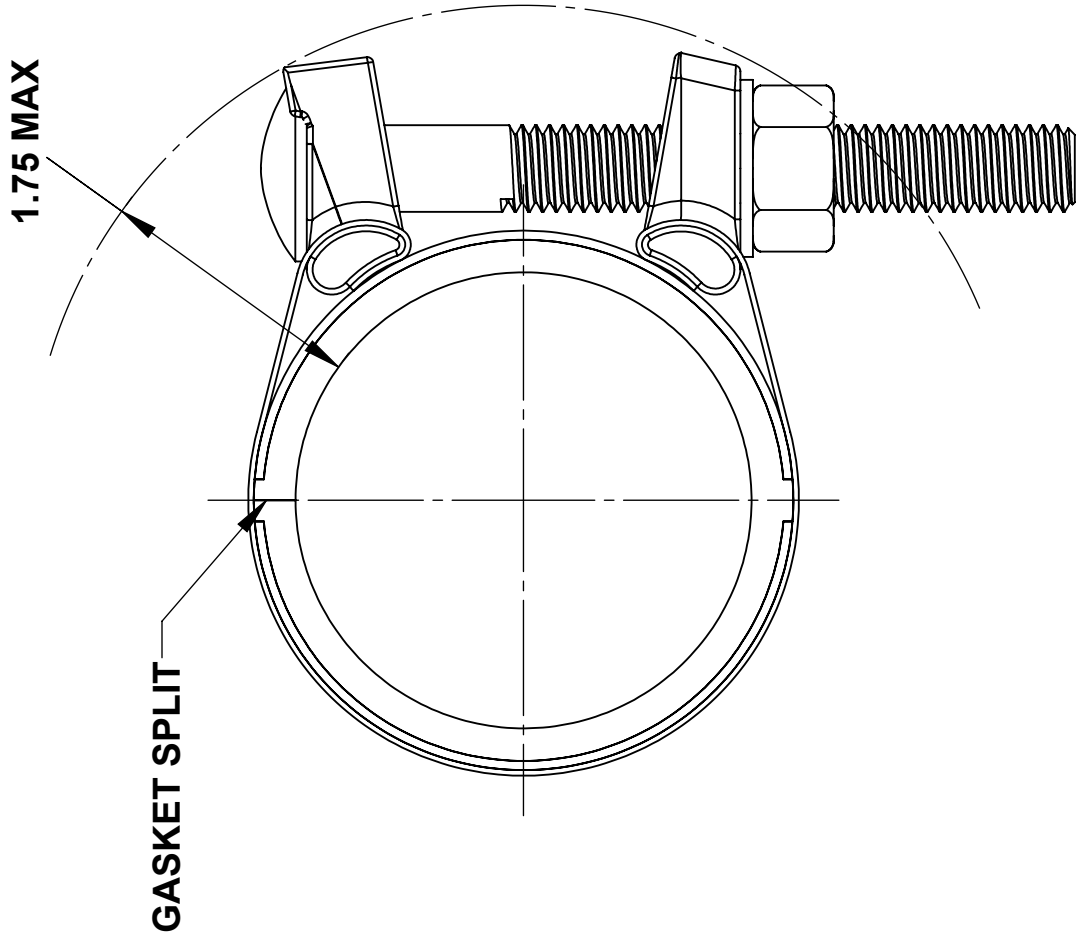

- NOTES:**
- SEE SMITH-BLAIR CATALOG FOR AVAILABLE PIPE DIAMETER AND WIDTH COMBINATIONS AS SOME COMBINATIONS ARE NOT AVAILABLE
 - 3.00" WIDE CLAMP SHOWN OTHER SIZES SIMILAR

NOMINAL PIPE SIZE	A	HARDWARE		SOCKET SIZE
		QUANTITY	SIZE	
0.5 - 1.50	3.00	1	3/8" x 3"	1 1/16"
	6.00	2		
	12.00	4		
2.00	3.00	1	7/16" x 4"	3/4"
	6.00	2		
	12.00	4		

TOLERANCES U.N.O. XX= ±.03 XXX= ±.015 FRACTIONS= * ANGLES= ±1° MACH. FIN=	NOTES: REMOVE BURRS AND SHARP EDGES DO NOT SCALE DWG.	APP'D	DATE
SCALE: N/A		CK'D	DATE
ALL DIMENSIONS ARE IN INCHES.		DRN	DATE
		CHD	5/22/15

TITLE
SPECIFICATION
FULL CIRCLE® REDI-CLAMP®
MODEL 244

Smith-Blair
 a xylem brand

P/N N/A

SPEC_244.DRW
 DWG. NO.

1 OF 1
 SHEET

6/28/16
 REV.