



Smith-Blair
a xylem brand

SPECIFICATION

FULL CIRCLE[®] COLLAR-LEAK REPAIR CLAMP

MODEL 229

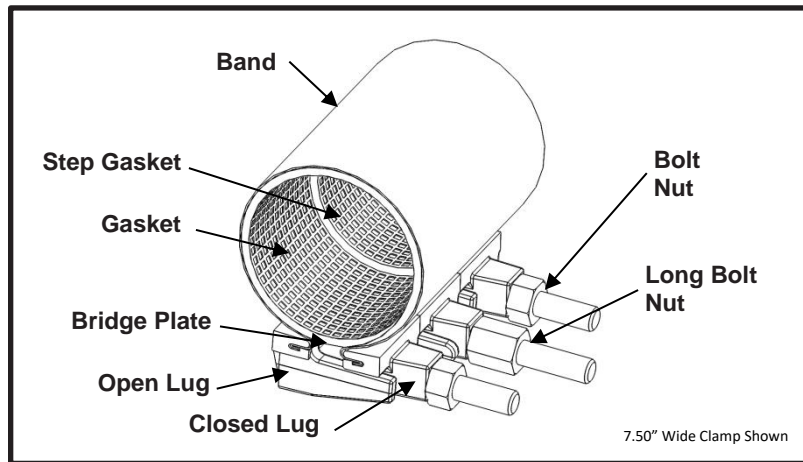

APPLICATIONS

- **Typical Uses**
 - Repair leaking PVC solvent weld bell pipe end (.25" maximum bell height).
 - Repair leaks at threaded steel couplings (.25 maximum coupling height).
- **Standard Pipe Sizes**
 - 2" to 12" nominal
- **Standard Widths**
 - 7.5", 12.5"
- **Type of Pipe**
 - Class 160 PVC Solvent Weld Bells, Carbon Steel
- **Working Pressure**
 - Up to 150 psi depending on type of pipe, type of repair, pipe diameter, service conditions and installation workmanship

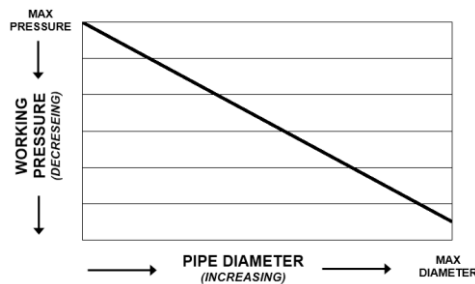

MATERIALS

- **Band**
 - Type 304 Stainless Steel per ASTM A240
 - Band Thickness: 24 gauge thick for clamps 4.50" diameter and smaller
20 gauge thick for clamps 4.80" diameter and larger
 - Hemmed ends for lug removal in tight applications



Smith-Blair
a xylem brand

SPECIFICATION

FULL CIRCLE[®] COLLAR-LEAK REPAIR CLAMP

MODEL 229

- **Lugs**
 - Cast using Ductile Iron 80-55-06 per ASTM A536
 - Flexi-Coat[®] fusion bonded epoxy finish
 - Slot cast in lug to capture band hem
 - Designed for drop in replaceable bolts
 - One open loop lug and one closed loop lug. The bolts do not have to be removed to install clamp, preventing lost hardware
 - Long interlocking fingers allow for up to 0.40 inches of range in clamp
 - Interchangeable lugs allow combining smaller diameter clamps to create larger diameter clamps
 - Mutually supporting sliding fingers assures proper bolt alignment and permits maximum clamping without bending bolts
- **Gasket**
 - Nitrile (Buna-N) per ASTM D2000
 - Gasket Thickness: 0.192" thickness for clamps 4.50" diameter and smaller
0.218" thickness for clamps 4.80" diameter and larger
 - Certified to NSF/ANSI 61-G & 372
 - Compounded to resist water, oil, natural gas, acids, alkalis, most (aliphatic) hydrocarbon fluids, and many other chemicals
 - Temperature range: -20°F to +180°F
 - Full 360° gridded face gasket provides maximum pipe support, reinforcement, and sealing pressure
 - Tapered ends allow for full circumferential sealing
 - Step gasket designed to compensate for the differential in the O.D. between the coupling or bell and the mating pipe (0.25" maximum O.D. differential)
 - Step gasket provides a shoulder to compress against the end of the coupling or bell to form an effective seal at the point of leak
- **Bridge Plate**
 - Type 304 Stainless Steel quarter-hard per ASTM A240
 - Molded and recessed into gasket
 - Preformed for uniform distribution of gasket pressure over the entire pipe circumference
- **Bolts**
 - HSLA Steel per AWWA C111/A21.11
 - 5/8"-11UNC x 6.00" long, Track Head Oval Neck
 - Fe/Zn coated per ASTM F1941-10
 - Rolled threads for improved physical characteristics, greater thread accuracy, and smooth surface finish
 - Drop in replaceable bolts
- **Long Bolts**
 - HSLA Steel per AWWA C111/A21.11
 - 5/8"-11UNC x 6.88" long, Track Head Oval Neck
 - Rolled threads for improved physical characteristics, greater thread accuracy and smooth surface finish
 - Fe/Zn coated per ASTM F1941-10
 - Used on clamps 4.50" diameter and smaller to facilitate the initial clamp installation
 - Drop in replaceable bolts
- **Nuts**
 - HSLA Steel per AWWA C111/A21.11
 - 5/8"-11UNC, Heavy Hex Semi-Finished
 - Fe/Zn coated per ASTM F1941-10



Smith-Blair
a xylem brand

SPECIFICATION

FULL CIRCLE® COLLAR-LEAK REPAIR CLAMP

MODEL 229

- **Long Nuts**
 - HSLA Steel per AWWA C111/A21.11
 - 5/8"-11UNC x 1.00" long, Heavy Hex Semi-Finished
 - Fe/Zn coated per ASTM F1941-10
 - Used to provide hand tightening during initial clamp installation

LISTINGS/STANDARDS

- Certified to NSF/ANSI 61 and NSF/ANSI 372
- Meets applicable portions of AWWA C230
- Flexi-Coat® Fusion-Bonded Epoxy Coating meets requirements of AWWA C213

OPTIONS

- Step on both ends
- Type 316 Stainless Steel band
- Type 304 Stainless Steel hardware with fluoropolymer coated nuts to prevent galling
- Type 316 Stainless Steel hardware with fluoropolymer coated nuts to prevent galling
- Alternative gasket material (e.g. Viton, EPDM, etc.)
- Taller bell or fitting heights

NOTES

- Full Circle® is a registered trademark of Smith-Blair
- These product specifications were correct at the time of publication and are subject to change without notice
- See the Smith-Blair website for part numbers and ordering information
- See the Smith-Blair website for warranty information
- See the Smith-Blair website for corrosion notice

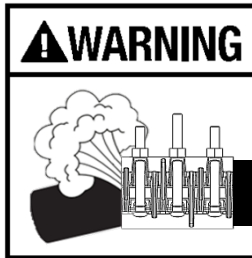

THIS PRODUCT DOES NOT RESTRAIN PIPE MOVEMENT. Proper anchoring is required to prevent pipe pull out. Failure to anchor or improper anchoring can result in dangerous pipe content escape, property damage, serious injury, and/or death. Read the product installation instructions prior to installing this product.

30 Globe Ave, Texarkana, AR 71854
Ph: 870-773-5127 • Fax: 870-773-5212
Toll-Free Numbers: Ph: 800-643-9705 • Fax: 800-648-6792

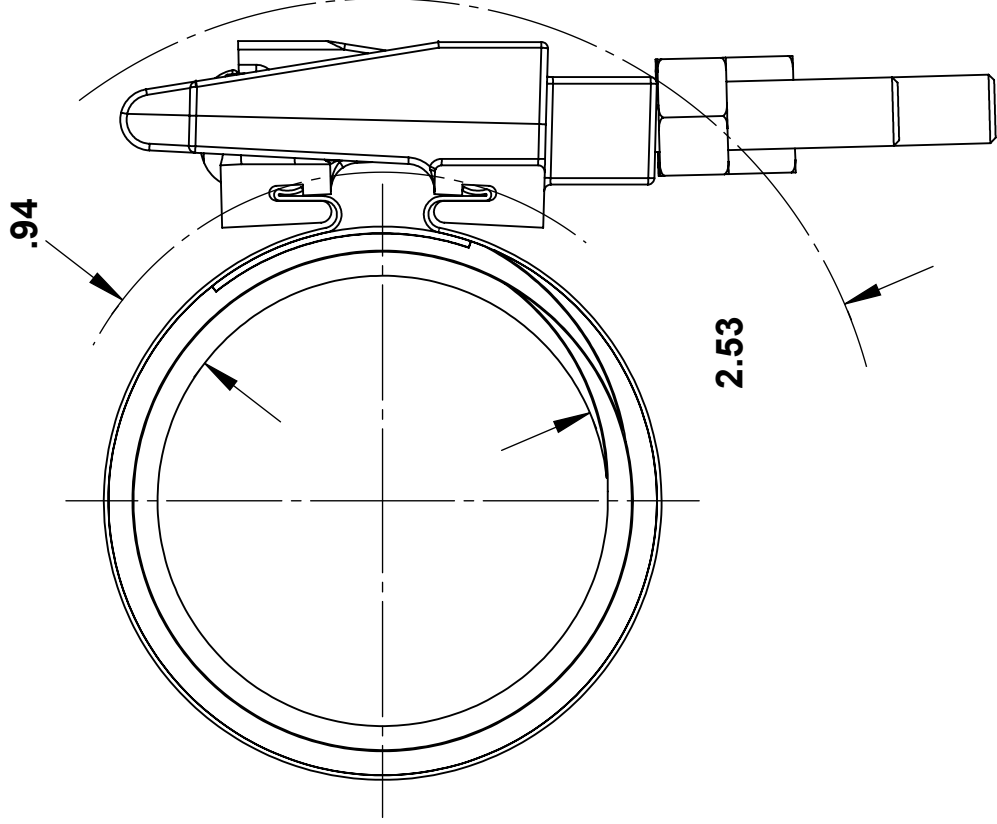
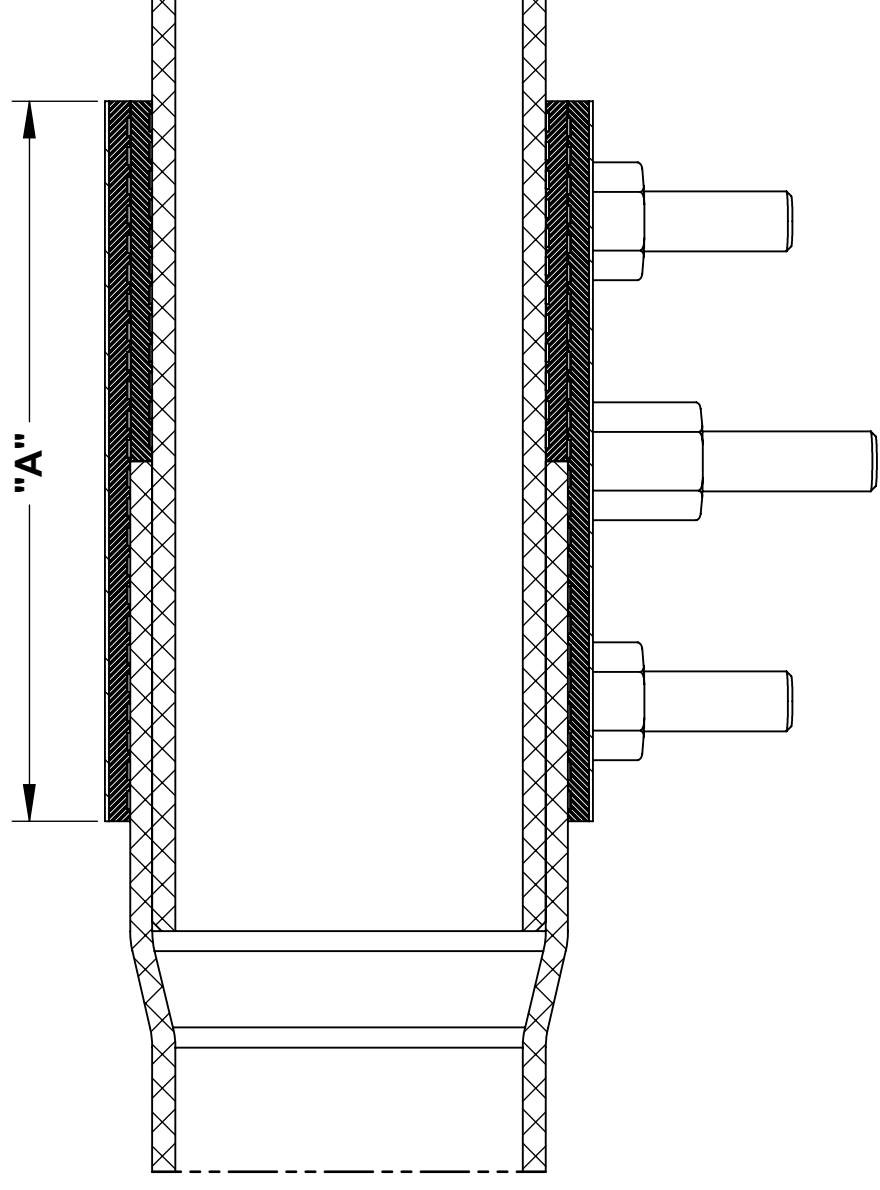

TYPICAL INSTALLATION

NOTES:

1. LONG OVAL NECK BOLTS ONLY PROVIDED ON CLAMPS 4.50" DIAMETER AND SMALLER
2. 7.50" WIDE CLAMP SHOWN OTHER SIZES SIMILAR
3. SEE SMITH-BLAIR CATALOG FOR AVAILABLE PIPE DIAMETER AND WIDTH COMBINATIONS AS SOME COMBINATIONS ARE NOT AVAILABLE

TOLERANCES U.N.O. XX= ±.03 XXX= ±.015 FRACTIONS= * ANGLES= ±1° MACH. FIN=	NOTES: REMOVE BURRS AND SHARP EDGES DO NOT SCALE DWG.	APP'D	DATE
	SCALE: N/A	CK'D	DATE
	ALL DIMENSIONS ARE IN INCHES.	DRN	DATE
		CHD	5/20/15

TITLE
SPECIFICATION
FULL CIRCLE® COLLAR-LEAK REPAIR CLAMP
MODEL 229

 Smith-Blair a xylem brand	P/N	N/A
	DWG. NO.	SPEC_229.DRW
	1 OF 1 SHEET	6/28/16 REV.

A	BOLT QUANTITY		LONG NUT QUANTITY	SOCKET SIZE
	SHORT	LONG		
7.50	2	1	1	1-1/16"
12.50	3	2	2	