

# HDU/DTT™

## Holdowns



This product is preferable to similar connectors because of (a) easier installation, (b) higher loads, (c) lower installed cost, or a combination of these features.

HDU holdowns are predeflected during the manufacturing process, virtually eliminating deflection under load due to material stretch. They use Strong-Drive® SDS Heavy-Duty Connector screws which install easily, reduce fastener slip and provide a greater net section when compared to bolts.

The DTT tension ties are designed for lighter-duty holdown applications on single 2x posts. The DTT1Z is installed with nails or Strong-Drive SD Connector screws and the DTT2Z installs easily with the Strong-Drive SDS Heavy-Duty Connector screws (included). The DTT1Z holdowns have been tested for use in designed shearwalls and prescriptive braced wall panels as well as prescriptive wood-deck applications (see pp. 314–315 for deck applications).

For more information on holddown options, contact Simpson Strong-Tie.

### HDU Features:

- Uses Strong-Drive SDS Heavy-Duty Connector screws which install easily, reduce fastener slip and provide a greater net section area of the post compared to bolts
- Strong-Drive SDS Heavy-Duty Connector screws are supplied with the holdowns to ensure proper fasteners are used
- No stud bolts to countersink at openings

**Material:** See table

**Finish:** HDU — galvanized; DTT1Z and DTT2Z — ZMAX® coating; DTT2SS — stainless steel

### Installation:

- See Holdown and Tension Tie General Notes on pp. 51–52.
- The HDU requires no additional washer; the DTT requires a standard-cut washer (included) be installed between the nut and the seat.
- Strong-Drive SDS Heavy-Duty Connector screws install best with a low-speed high-torque drill with a  $\frac{3}{8}$ " hex-head driver.
- Fasteners and crescent washer are included with the holdowns. To order replacements, order part no. SDS25212-HDU\_. (Fill in the size needed, e.g., HDU2.)

**Codes:** See p. 13 for Code Reference Key Chart

**Web Applications:** Visit [app.strongtie.com/pfd](http://app.strongtie.com/pfd) to access our Post-to-Foundation Designer web application.

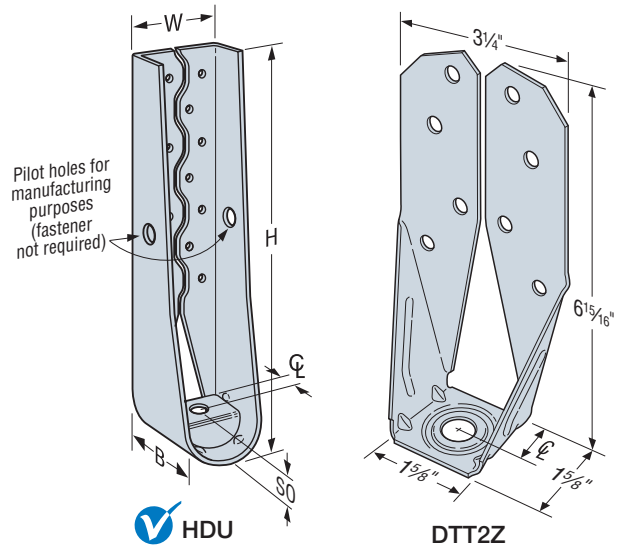

**HDU**

**DTT2Z**  
US Patent  
8,555,580

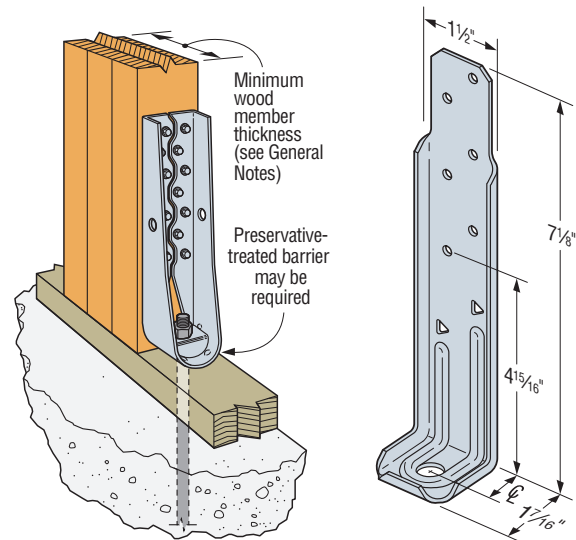

**Vertical HDU Installation**

**DTT1Z**  
US Patent  
10,865,558

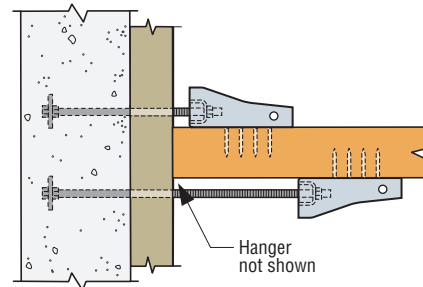

**Horizontal HDU Offset Installation**  
(plan view)

See Holdown and Tension Tie General Notes on pp 51–52.

# HDU/DTT™

## Holdowns (cont.)

These products are available with additional corrosion protection. For more information, see p. 16.

**SS** For stainless-steel fasteners, see p. 23.

**SD** Many of these products are approved for installation with Strong-Drive® SD Connector screws. See pp. 362–366 for more information.

Model No.	Ga.	Dimensions (in.)					Fasteners (in.)		Minimum Wood Member Size (in.)	Allowable Tension Loads (160)			Code Ref.	
		W	H	B	CL	SO	Anchor Bolt Dia. (in.)	Wood Fasteners		DF/SP	SPF/HF	Deflection at Allowable Load (in.)		
DTT1Z	14	1 ½	7 ⅞	1 ⅞	¾	¾	¾	(6) #9 x 1 ½" SD	1 ½ x 3 ½	840	840	0.17	IBC®, FL, LA	
								(6) 0.148 x 1 ½		910	640	0.167		
								(8) 0.148 x 1 ½		910	850	0.167		
DTT2Z	14	3 ¼	6 ⅝	1 ⅝	¾	¾	½	(8) ¼ x 1 ½ SDS	1 ½ x 3 ½	1,825	1,800	0.105		
								(8) ¼ x 1 ½ SDS	3 x 3 ½	2,145	1,835	0.128		
DTT2Z-SDS2.5								(8) ¼ x 2 ½ SDS	3 x 3 ½	2,145	2,105	0.128		
HDU2-SDS2.5	14	3	8 ⅞	3 ¼	1 ⅝	1 ⅝	¾	(6) ¼ x 2 ½ SDS	3 x 3 ½	3,075	2,215	0.088		
HDU4-SDS2.5	14	3	10 ⅝	3 ¼	1 ⅝	1 ⅝	¾	(10) ¼ x 2 ½ SDS	3 x 3 ½	4,565	3,285	0.114		
HDU5-SDS2.5	14	3	13 ⅞	3 ¼	1 ⅝	1 ⅝	¾	(14) ¼ x 2 ½ SDS	3 x 3 ½	5,645	4,340	0.115		
HDU8-SDS2.5	10	3	16 ⅝	3 ½	1 ⅝	1 ½	7 ⅞	(20) ¼ x 2 ½ SDS	3 x 3 ½	6,765	5,820	0.11		
									3 ½ x 3 ½	6,970	5,995	0.116		
									3 ½ x 4 ½	7,870	6,580	0.113		
HDU11-SDS2.5	10	3	22 ¼	3 ½	1 ⅝	1 ½	1	(30) ¼ x 2 ½ SDS	3 ½ x 5 ½	9,535	8,030	0.137		
									3 ½ x 7 ¼	11,175	9,610	0.137		
HDU14-SDS2.5	7	3	25 ⅞	3 ½	1 ⅝	1 ⅝	1	(36) ¼ x 2 ½ SDS	3 ½ x 5 ½	10,770	9,260	0.122	—	
									3 ½ x 7 ¼	14,390	12,375	0.177	IBC, FL, LA	
									5 ½ x 5 ½	14,445	12,425	0.172		

1. HDU14 requires heavy-hex anchor nut to achieve tabulated loads (supplied with holdown).
2. HDU11 and HDU14 loads on 4x6 post are applicable to installation on either the narrow or the wide face of the post.
3. **Fasteners:** Nail dimensions are listed diameter by length. SD and SDS screws are Simpson Strong-Tie Strong-Drive SD Connector and SDS Heavy-Duty Connector screws. See pp. 23–24 for fastener information.

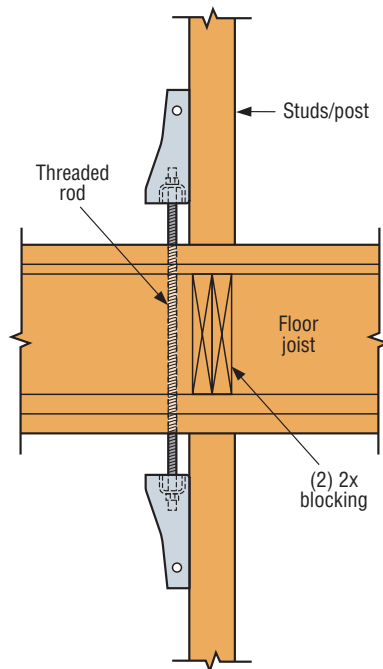

Typical HDU Tie Between Floors

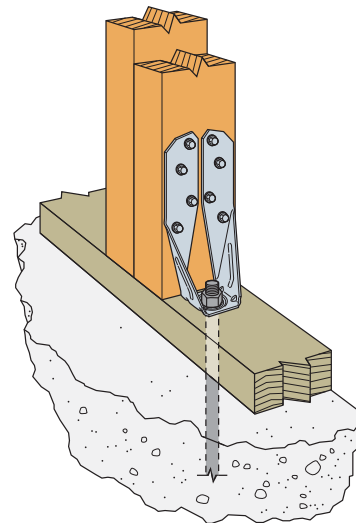

Typical DTT2Z Installation