



Cutting Attachments, Spare Parts and Accessories

2019



Cutting Attachments

Mowing heads	4
Grass cutting blades.....	5
Brush knife.....	6
Circular saw blades	6
Shredder blade.....	7
Safety instructions	7

Reference table

Cutting Attachments - Brushcutters.....	8
---	---

Cutting Attachments - Mounting

FE 55.....	17
FR 85, 85 T + FS-KM, 106, 108	18
FR 85, 130 T + FSB-KM (a)	21
FR 130 T, 131 T + FS-KM (a), FR 410 (b), 460 (b).....	22
FR 130 T + FS-KM (a), FR 220, 350, 410 (b), 450, 460 (b), 480	24
FR 235.....	28
FS 25-4, 44, 55 (a), 55 T + FS-KM.....	29
FS 36, 40 (a), 72, 75.....	32
FS 38, 40 (a).....	33
FS 45, 50 (a).....	34
FS 48, 50 (a), 51, 52, 56 (b), 62	35
FS 55 (a), 56 (b), 70	36
FS 65, 80 (a), 90 (a)	38
FS 80 (a), 85 (a)	40
FS 80 (a), 85 (b), 85 T + FS-KM, 87, 90 (c), 100 (d), 110	43
FS 66, 74, 76, 81, 86 (a), 88, 106, 108.....	47
FS 86 (a), 96.....	50
FS 89, 91, 111 (a), 131.....	53
FS 94 (a).....	56
FS 94.....	57
FS 100 RX.....	59
FS 111 RX.....	60
FS 120, 250 (a).....	61
FS 235.....	64
FS 235 R	66
FS 120, 130, 200 (a), 240, 250, 260 R (b), 460 R (c).....	67
FS 240, 240 R, 260 R (a)	71
FS 150, 151, 200 (a), 202, 353, 410 (b).....	74
FS 160, 220, 280, 290, 300, 310, 350, 380, 400, 450, 480	76
FS 160, 180, 220, 280, 300, 350, 400, 450.....	81
FS 260 (a), 311, 360 (b), 410 (b, c), 460 (a, c), 490 (c).....	85
FS 360 (a), 420.....	89
FS 410 K (a, b), 460 K (b, c), 490 K (b).....	91
FS 500, 550.....	93
FS 510, 560.....	98
FT 250.....	101
FSA 45.....	102
FSA 56, 57.....	103
FSA 65, 85.....	104
FSA 90.....	105
FSA 130.....	106
FSA 130 R.....	109
KMA 130 R + FS-KM (a)	111
FSE 31, 41.....	113
FSE 52.....	114
FSE 60, 71, 81.....	115
FSE 65.....	116

KA 85, 120, 250, + FS (a).....	117
KA 85, 120, 250, KR 85, + FS (a).....	120
KM 55, 56 + FS-KM (a)	123
KM 55, 56 + FS-KM (a)	125
KM 55, 56, 85, 90, 91, 100, 110, 111 + FSB-KM (a)	128
KM 55, 56, 85, 90, 91, 100, 110, 111 + FSB-KM (a)	129
KM 85, 90, 91, 94, 100, 110, 111, 130, 131, + FS-KM (a)	130
KM 85, 90, 94, 100, 110, 130, + FS-KM (a)	133
MM 55, 56 + FS-MM.....	137

Spare Parts and Accessories

Polymatic 40-2.....	138
TrimCut 30-2.....	139
TrimCut 31-2.....	140
TrimCut 40-2.....	142
TrimCut 41-2.....	143
TrimCut 50-2.....	144
TrimCut 51-2.....	145
AutoCut 2-2	147
AutoCut C 4-2.....	147
AutoCut 5-2	148
AutoCut C 5-2.....	148
AutoCut C 6-2.....	149
AutoCut 11-2	150
AutoCut 21-2	151
AutoCut 25-2	152
AutoCut C 25-2.....	153
AutoCut C 26-2.....	154
AutoCut 30-2	155
AutoCut 36-2	156
AutoCut 36-2	157
AutoCut 40-2	158
AutoCut 46-2	159
AutoCut 46-2	160
AutoCut 40-4	161
AutoCut 56-2	162
AutoCut 56-2	163
SuperCut 20-2.....	164
SuperCut 40-2	165
PolyCut 2-2.....	166
PolyCut 5-3.....	167
PolyCut 6-3.....	167
PolyCut 7-3.....	168
PolyCut 20-3.....	169
PolyCut 27-3.....	170
PolyCut 40-3.....	171
PolyCut 41-3.....	171
PolyCut 47-3.....	172
DuroCut 5-2.....	173
DuroCut 20-2.....	174
DuroCut 40-4.....	175
FixCut 5-2.....	176
FixCut 25-2.....	177
FixCut 31-2.....	178

Mowing lines, round.....	179
Mowing lines, round, quiet.....	180
Mowing lines, square.....	181
Mowing lines, pentagonal.....	182
Mowing lines, round, pre-cut.....	183
Mowing lines, pentagonal, pre-cut.....	183
Mowing line, serrated, pre-cut.....	184
Mowing lines CF3 Pro.....	184
Balancer, Sharpening Instructions and Sharpening Tools.....	185
Transport guard for metal cutting attachments.....	189

STIHL KombiSystem

STIHL KombiTools.....	192
KombiTools for power tools with split drive tube.....	194







STIHL Attachments

Attachments for STIHL power tools.....	196
--	-----

STIHL MultiSystem

MultiTools for STIHL MM 55, 56.....	200
-------------------------------------	-----

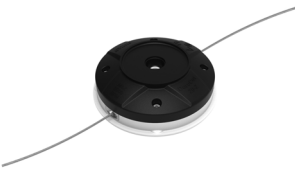
Mowing heads

	<p>STIHL SuperCut</p> <p>The mowing line is adjusted automatically. For mowing lawn edges, small areas of grass and around obstacles.</p>
	<p>STIHL AutoCut</p> <p>The mowing line is adjusted semi-automatically by tapping the mowing head. For mowing lawn edges, small areas of grass and around obstacles.</p>
	<p>STIHL TrimCut</p> <p>The mowing line is adjusted manually. For mowing lawn edges, small to medium-sized areas of grass and around obstacles.</p>
	<p>STIHL PolyCut</p> <p>High cutting capacity through the use of plastic blades. For mowing weeds around obstacles and small fields. In larger versions, mowing lines for cutting grass can be used instead of the plastic blades.</p>
	<p>STIHL DuroCut</p> <p>For use with precut lengths of nylon line by hand. Different sizes and types of mowing lines can be used in each DuroCut version. For mowing low-growing grass and around solid obstacles.</p>
	<p>STIHL FixCut</p> <p>For use with precut lengths of nylon line by hand. For mowing lawn edges, small areas of grass and around obstacles.</p>

Grass cutting blades

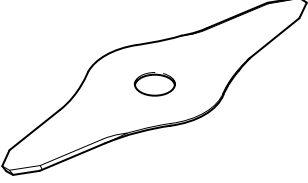
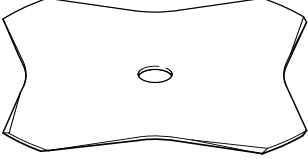
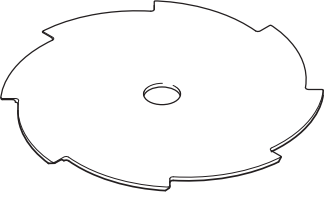
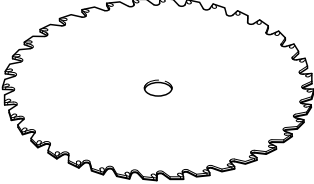
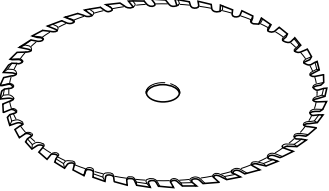
 <p>681KT1101 KN</p>	<p>Grass cutting blade, 2 blades</p> <p>Robust; high cutting capacity, particularly in weeds and heavy growth; very good acceleration.</p>
 <p>681KT759 KN</p>	<p>Grass cutting blade, 4 blades</p> <p>Robust, for large areas, high cutting capacity in dense growth, such as matted grass and weeds.</p>
 <p>681KT406 KN</p>	<p>Grass cutting blade, 8 teeth</p> <p>Robust, for large areas with low cutting resistance, high capacity in sparse growth such as dry grass, fern, stinging nettles and reed.</p>
 <p>681KT516 KN</p>	<p>Grass cutting blade "Special"</p> <p>Equipped with carbide-tipped teeth, very suitable for heavy-duty operating conditions, offers long service and edge life. For mowing tough grass.</p>
 <p>681KT873 KN</p>	<p>Grass cutting blade, low impact</p> <p>Highly recommended in areas where there is a risk of flying objects. For mowing grass.</p>

Brush knives

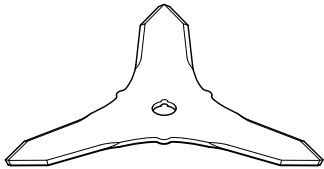
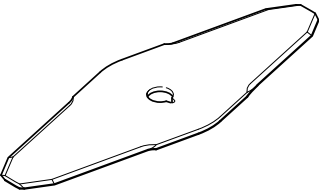
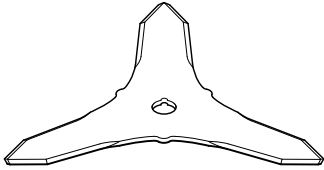
 <p style="writing-mode: vertical-rl; transform: rotate(180deg);">681K1405 KN</p>	<p>Brush knife, 3 blades</p> <p>For heavy-duty cutting and thinning thicket, scrub and bushes; also for cutting tough, matted grass. Can be used with special shredding deflector for "shredding" applications.</p>
 <p style="writing-mode: vertical-rl; transform: rotate(180deg);">681K1415 KN</p>	<p>Brush knife, "Special" 2 blades</p> <p>Made of special wear resistant steel: For heavy-duty cutting, achieves high cutting performance and cut quality. Good coverage of large areas when used as grass cutting blade.</p>
 <p style="writing-mode: vertical-rl; transform: rotate(180deg);">681K1405 KN</p>	<p>Brush knife, "Special" 3 blades</p> <p>For use as "standard" brush knife but made of special wear resistant steel: With longer edge life for tough applications.</p>

Circular saw blade

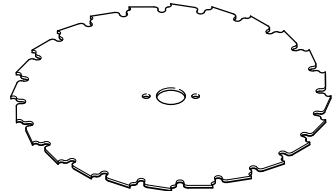
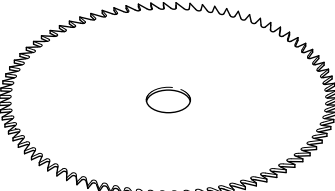
 <p style="writing-mode: vertical-rl; transform: rotate(180deg);">681K1408 KN</p>	<p>Chisel Tooth Circular Saw Blade</p> <p>Same applications as scratcher blade, but produces quieter and softer cut, low kickback. very easy to sharpen, good cutting capacity.</p>
 <p style="writing-mode: vertical-rl; transform: rotate(180deg);">681K1407 KN</p>	<p>Scratcher Tooth Circular Saw Blade</p> <p>Used for cutting knotty bushes, brush, woody scrub, hedges and saplings, particularly good cutting capacity.</p>

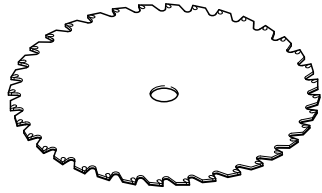

681KT335 KN

Carbide Tipped Circular Saw Blade

Very good cutting capacity; also suitable for cutting hedges.

Shredder blades

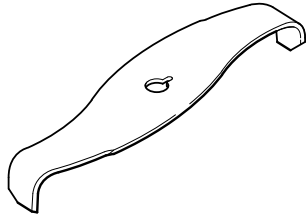

681KT382 KN

Shredder blade, 2 blades





Made of special wear resistant steel: Specially contoured blade combined with shredding deflector is ideal for "shredding", thinning and clearing heavy growth, such as rank shrubs, hedges, etc.







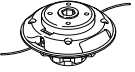
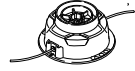

Safety information





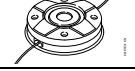
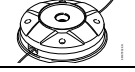

A transport guard is required for metal cutting attachments.



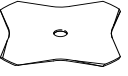

When using grass cutting blades, a barrier bar is required on the loop handle.

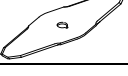
The use of circular saw blades is only permitted on machines with bike handle.

			FR 131 T + FS-KM, FR 220	FR 235	FR 410, 450, 460, 480	FS 38, 40 ④, 45, 50 ④	FS 55, 56 ④, 70	FS 55 R, 56 R ④, 70 R	FS 80 ⑥, 85, 89	FS 80 R ⑥, 85 R, 89 R	FS 94	FS 94 R	FS 91, 111	FS 91 R, 111 R	FS 111 RX	FS 120 R	FS 120, 250	FS 131	FS 131 R
	SuperCut 20-2	4002 710 2162	•	•	•		•	•	•	•	•	•	•	•	•	•	•	•	•
	SuperCut 40-2	4003 710 2140																	
	AutoCut 2-2	4008 710 2100																	
	AutoCut C 4-2	4006 710 2121																	
	AutoCut 5-2	4006 710 2100				•													
	AutoCut C 6-2	4006 710 2126				•													
	AutoCut 11-2	4004 710 2105																	
	AutoCut 25-2	4002 710 2108	•	•	•		•	•	•	•	•	•	•	•	•	•	•	•	•
	AutoCut C 26-2	4002 710 2169	•	•	•		•	•	•	•	•	•	•	•	•	•	•	•	•
	AutoCut 36-2	4002 710 2170		•									•	•	•	•	•	•	•
	AutoCut 46-2	4003 710 2115																	
	AutoCut 56-2	4005 710 2107																	
	TrimCut 31-2	4002 710 2152	•		•		•	•	•	•			•	•	•	•	•	•	•
	TrimCut 41-2 ②	4003 710 2104																	
	TrimCut 51-2 ③	4005 710 2103																	

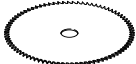
			FR 131 T + FS-KM, FR 220																
			FR 235		FR 410, 450, 460, 480	FS 38, 40 ④, 45, 50 ④	FS 55, 56 ④, 70	FS 55 R, 56 R ④, 70 R	FS 80 ⑤, 85, 89	FS 80 R ⑤, 85 R, 89 R	FS 94	FS 94 R	FS 91, 111	FS 91 R, 111 R	FS 111 RX	FS 120 R	FS 120, 250	FS 131	FS 131 R
	FixCut 31-2	4001 710 2105	•		•		•	•	•	•	•	•	•	•	•	•	•	•	•
	PolyCut 2-2	4008 710 2102																	
	PolyCut 5-3	4004 710 2131																	
	PolyCut 7-3	4006 710 2127				•													
	PolyCut 27-3	4002 710 2176	•	•	•		•	•	•	•	•	•	•	•	•	•	•	•	•
	PolyCut 47-3	4003 710 2117																	
	DuroCut 5-2	4006 710 2131				•													
	DuroCut 20-2	4002 710 2182	•	•	•		•	•	•	•	•	•	•	•	•	•	•	•	•
	DuroCut 40-4 ①	4005 710 2114																	

			FR 131 T + FS-KM, FR 220	FR 235	FR 410, 450, 460, 480	FS 38, 40 ④, 45, 50 ④	FS 55, 56 ④, 70	FS 55 R, 56 R ④, 70 R	FS 80 ⑤, 85, 89	FS 80 R ⑤, 85 R, 89 R	FS 94	FS 94 R	FS 91, 111	FS 91 R, 111 R	FS 111 RX	FS 120 R	FS 120, 250	FS 131	FS 131 R
	ø 230-2	4001 713 3805	(•)	(•)	(•)		•	(•)	•	(•)	•	(•)	•	(•)		(•)	•	•	(•)
	ø 260-2	4001 713 3812	(•)	(•)	(•)				•	(•)	•	(•)	•	(•)		(•)	•	•	(•)
	ø 230-4	4000 713 3801																	
	ø 230-4	4001 713 3801	(•)	(•)	(•)		•	(•)	•	(•)	•	(•)	•	(•)		(•)	•	•	(•)
	ø 230-8	4001 713 3803	(•)	(•)	(•)		•	(•)	•	(•)	•	(•)	•	(•)		(•)	•	•	(•)
	ø 255-8	4000 713 3802																	
	ø 250-40	4000 713 3806																	
	ø 250-40	4001 713 3806	(•)		(•)				•	(•)			•	(•)		(•)	•	•	(•)
	ø 250-44	4000 713 3811																	
	ø 250-44	4001 713 3811	(•)		(•)				•	(•)			•	(•)		(•)	•	•	(•)
	ø 305-2	4000 713 4103																	
	ø 250-3	4112 713 4100	(•)	(•)	(•)				•	(•)			•	(•)		(•)	•	•	(•)
	ø 300-3	4119 713 4100																	
	ø 350-3	4000 713 41005																	
	ø 350-3	4110 713 4100																	
	ø 270-2	4000 713 3903																	
	ø 320-2	4000 713 3902																	

			FR 131 T + FS-KM, FR 220	FR 235	FR 410, 450, 460, 480	FS 38, 40 ④, 45, 50 ④	FS 55, 56 ④, 70	FS 55 R, 56 R ④, 70 R	FS 80 ⑤, 85, 89	FS 80 R ⑤, 85 R, 89 R	FS 94	FS 94 R	FS 91, 111	FS 91 R, 111 R	FS 111 RX	FS 120 R	FS 120, 250	FS 131	FS 131 R
	∅ 200-44	4000 713 4200																	
	∅ 200-80	4112 713 4201							•				•				•	•	
	∅ 225-48	4000 713 4205																	
	∅ 250-100	4001 713 4202																	
	∅ 200-22	4112 713 4203							•				•				•	•	
	∅ 200-22	4119 713 4200																	
	∅ 225-24	4000 713 4201																	
	∅ 225-24	4110 713 4204																	
	∅ 225-36	4000 713 4211																	
	∅ 200-22 HP – High Performance	4000 713 4203																	
	∅ 200-22 HP – High Performance	4001 713 4203							•				•				•	•	
	∅ 225-22 HP – High Performance	4000 713 4202																	

Note:

See following pages for information on cutting attachments for older models.

Key to symbols:

- = including item No.
- = approved
- (•) = approved **only** for loop handle with barrier bar
- = not approved
- (A) = not illustrated
- (B) = special accessory only
- (C) = no longer available from factory
- (D) = not available as separate item
- ∅ = diameter

Notes:

- ① for M12 and M14 threads
- ② for M12 thread
- ③ for M14 thread
- ④ from 2008
- ⑤ from 1996
- ⑥ from 2006
- ❶ approved on FS 160, 220, 280 only with series 4128 gearbox
- ❷ not approved in EU, approved outside the EU only for loop handle with barrier bar
- ❸ from 2018 for M8 thread
- ❹ up to 2017 for M12 thread
- ❺ approved on FS 360 only

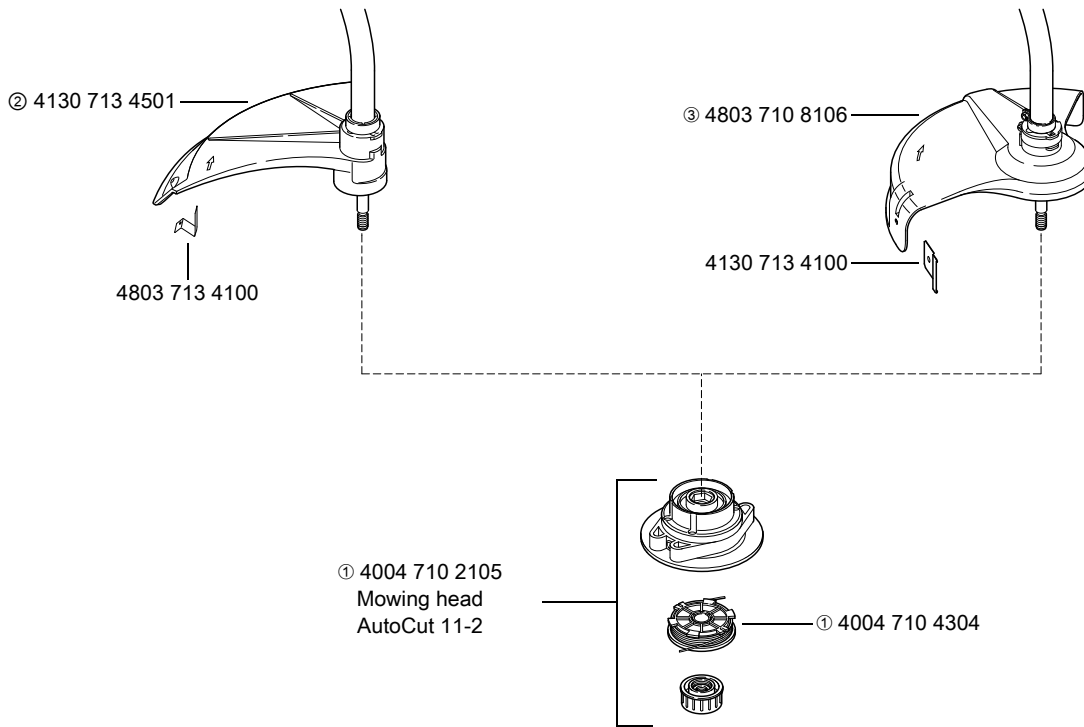

- ① Use quiet mowing line
- ② Not approved in the EU
- ③ Part is mandatory in the EU

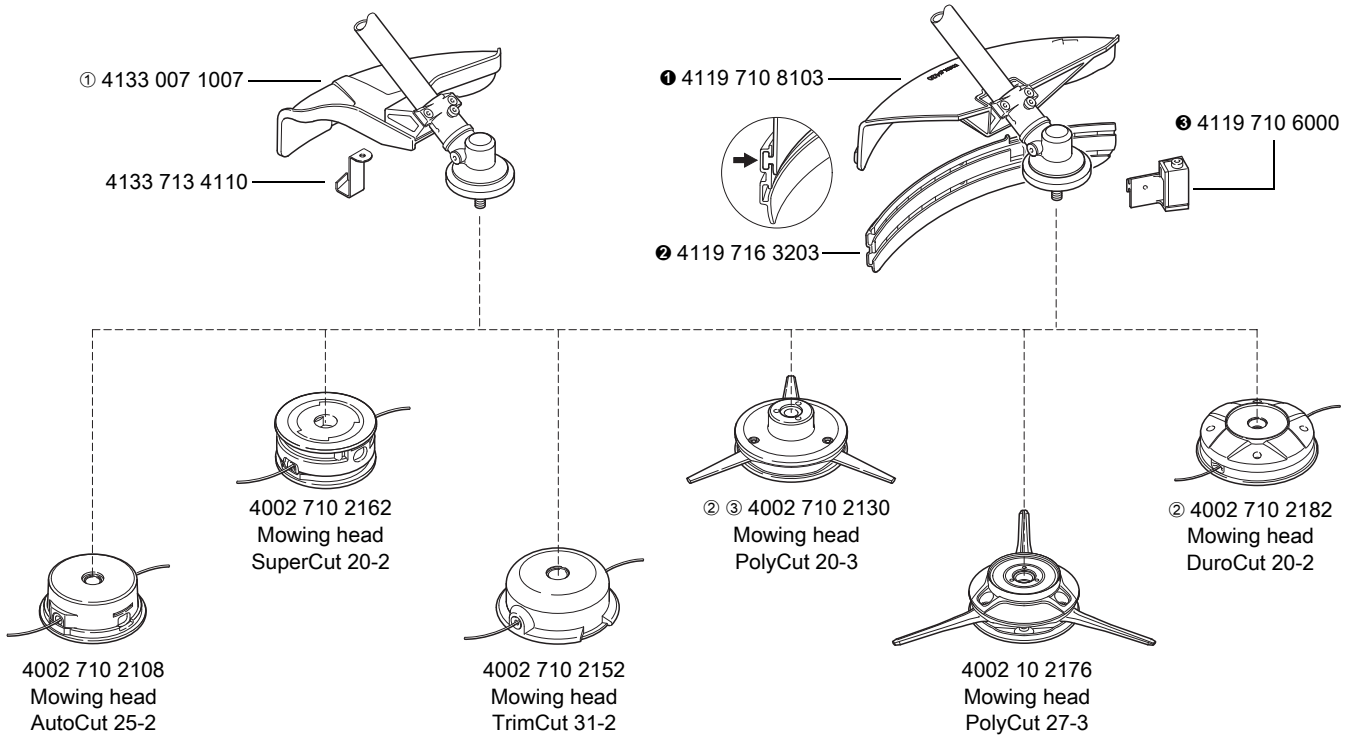

0000-GXX-5725-A0

① Approved in AUS, NZ only: 4133 007 1008

③ No longer available

② Not approved for FR 106, 108

① + ② + ③ = 4119 007 1027

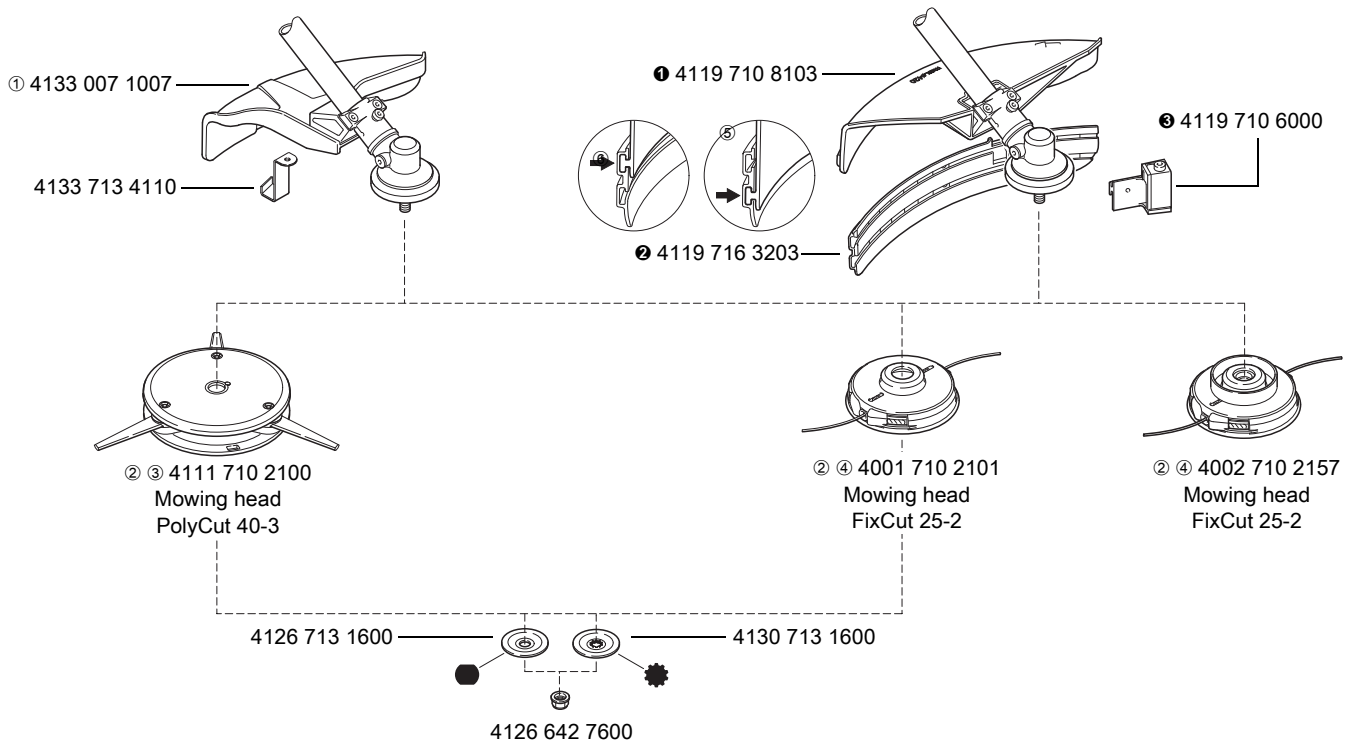

381KT856-A1

① Approved in AUS, NZ only: 4133 007 1008

⑤ For 4111 710 2100

② No longer available

⑥ For 4001 710 2101, 4002 710 2157

③ Not approved for FR 85, 85 T

① + ② + ③ = 4119 007 1027

④ Not approved for FR 106, 108

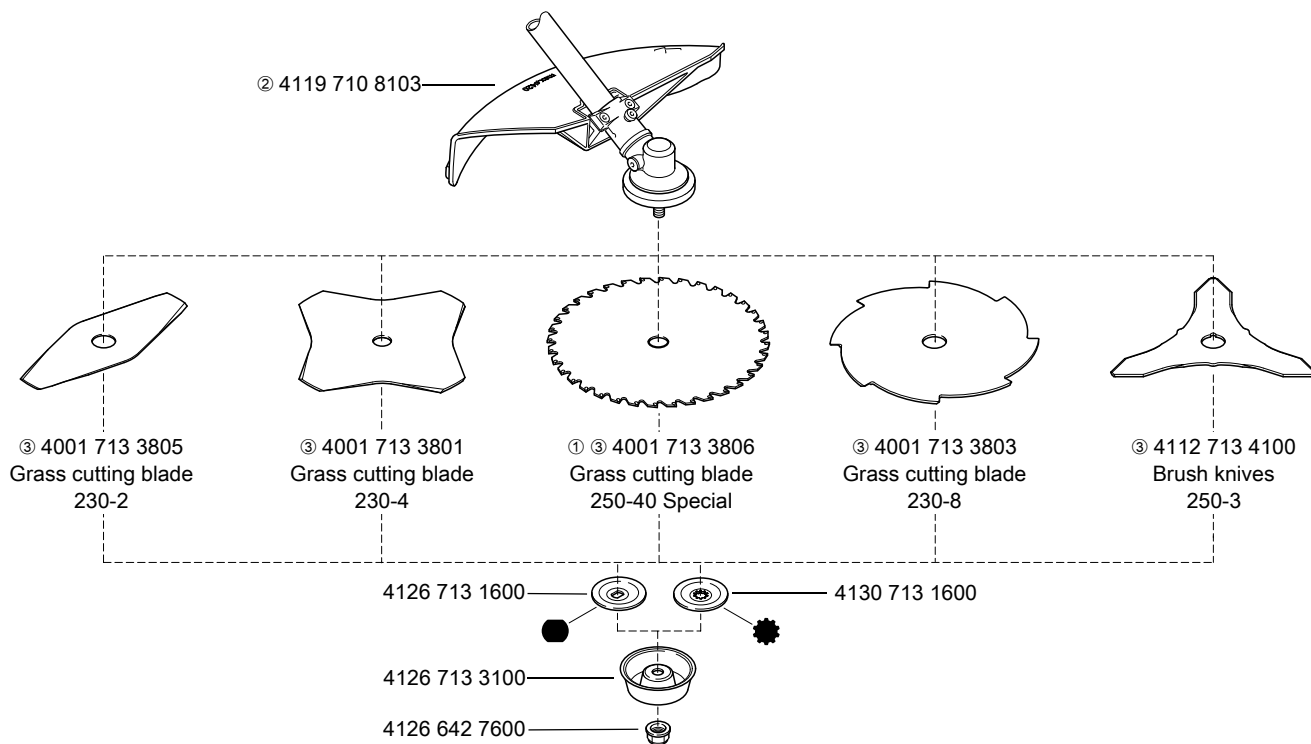

681KT857 KN

① Not approved for FR 106, 108

② Deflector for AUS, NZ see illustration marked "AUS, NZ"

③ Barrier bar required on loop handle

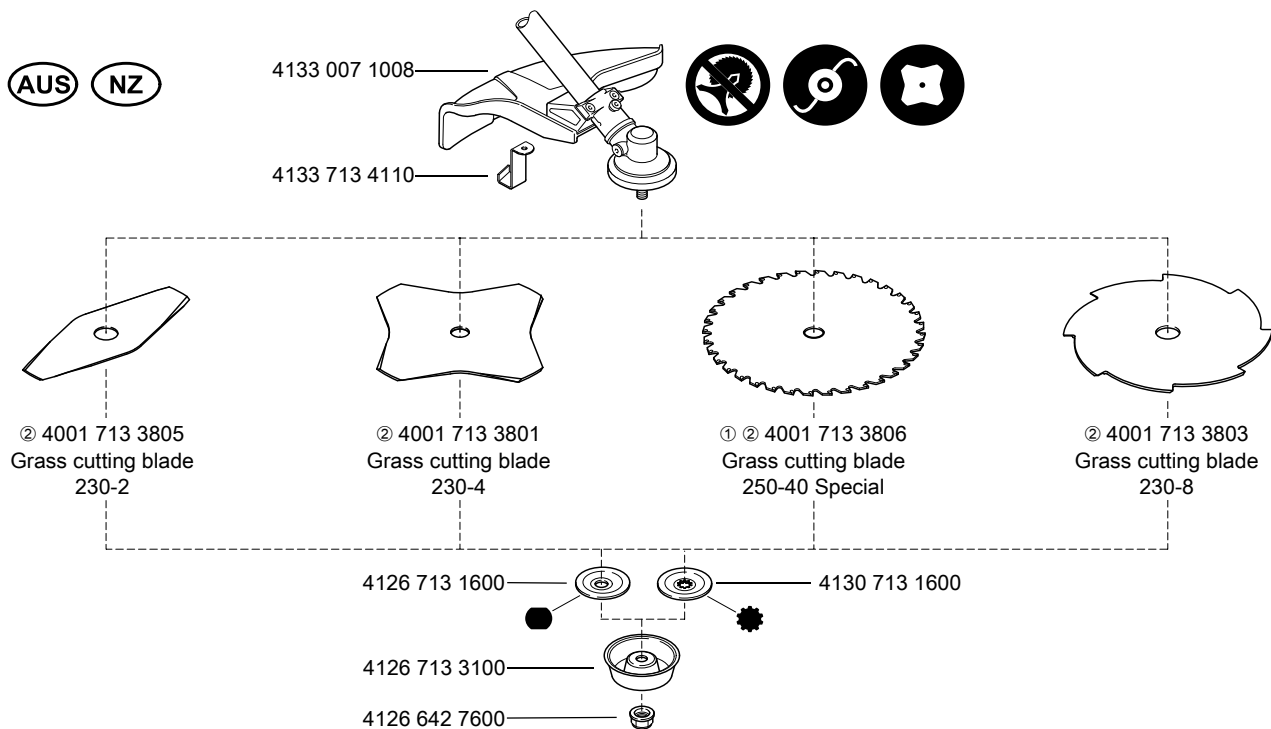

681KT582 KN

① Not approved for FR 106, 108

② Barrier bar required on loop handle

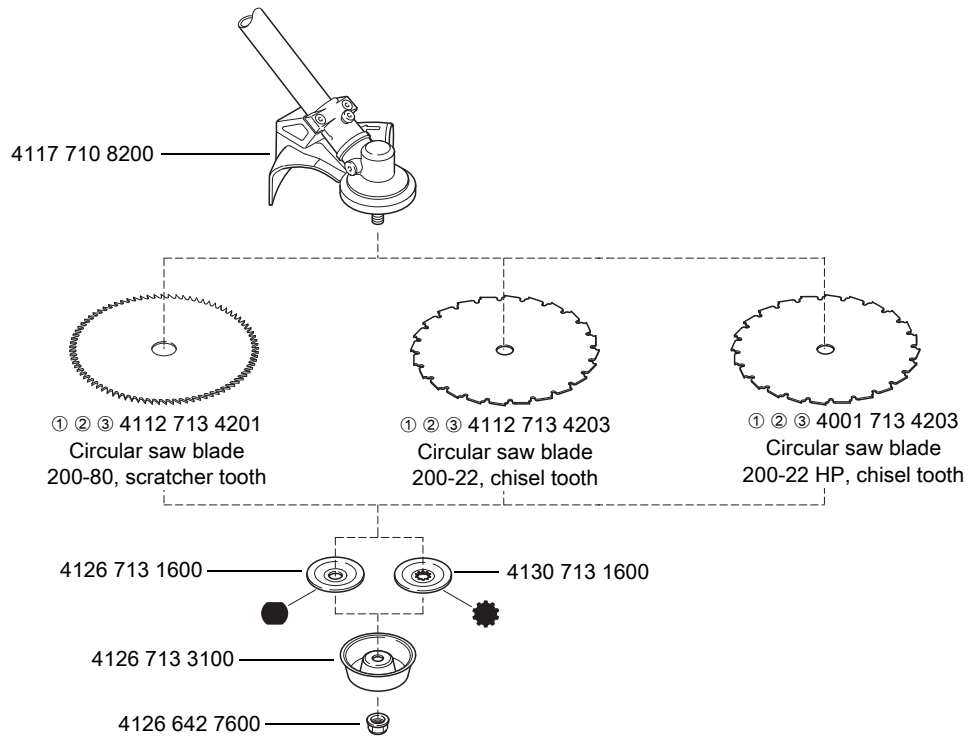

681KT868-A1

- ① Not approved for FR 85, FR 85 T
- ② Barrier bar required on loop handle
- ③ Only approved for pruning to maintain tree quality and pruning within reach

(a) up to 2017

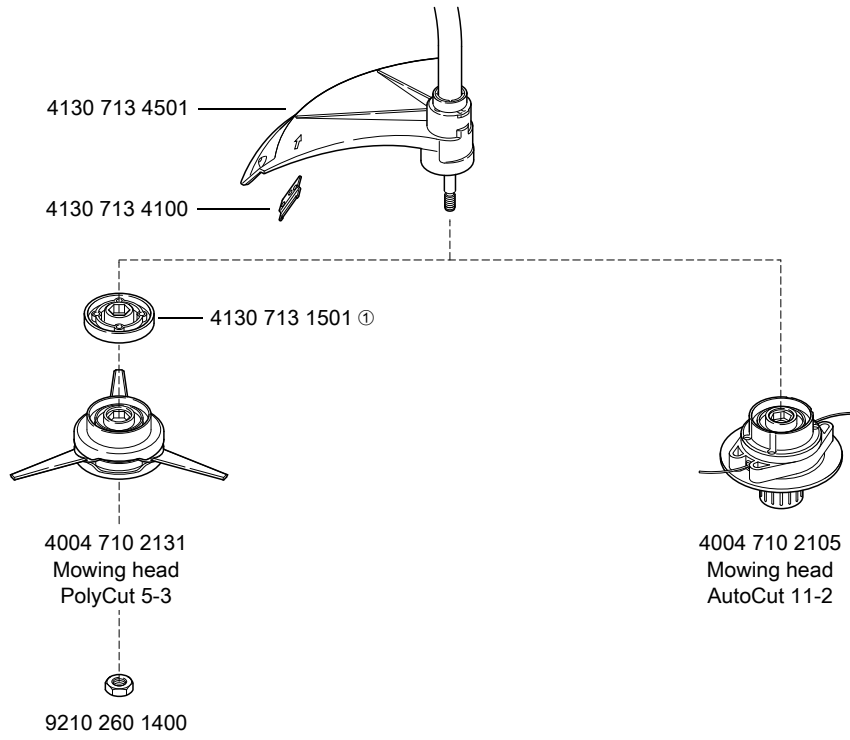

① Part supplied with mowing head

(a) from 2015 (b) from 2017

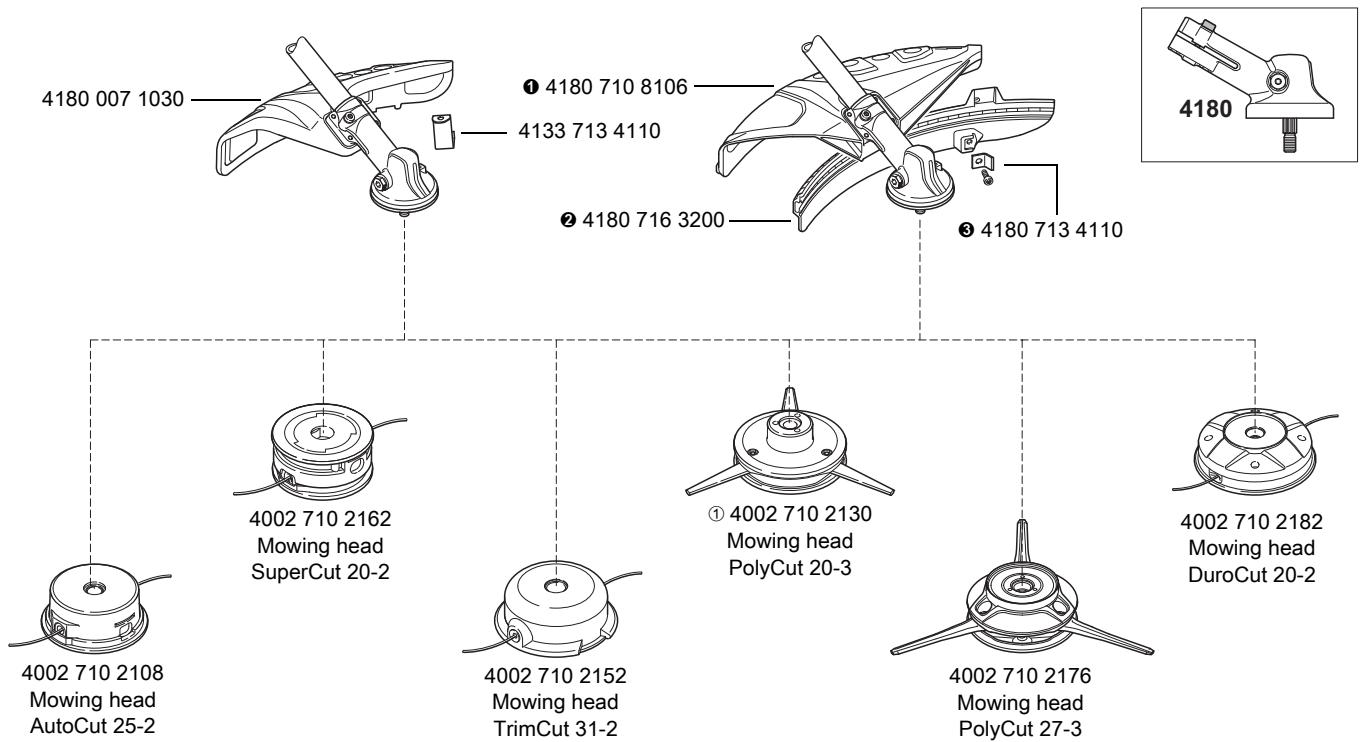

0000-GXX-5726-A0

① No longer available

❶ + ❷ + ❸ = 4180 007 1028

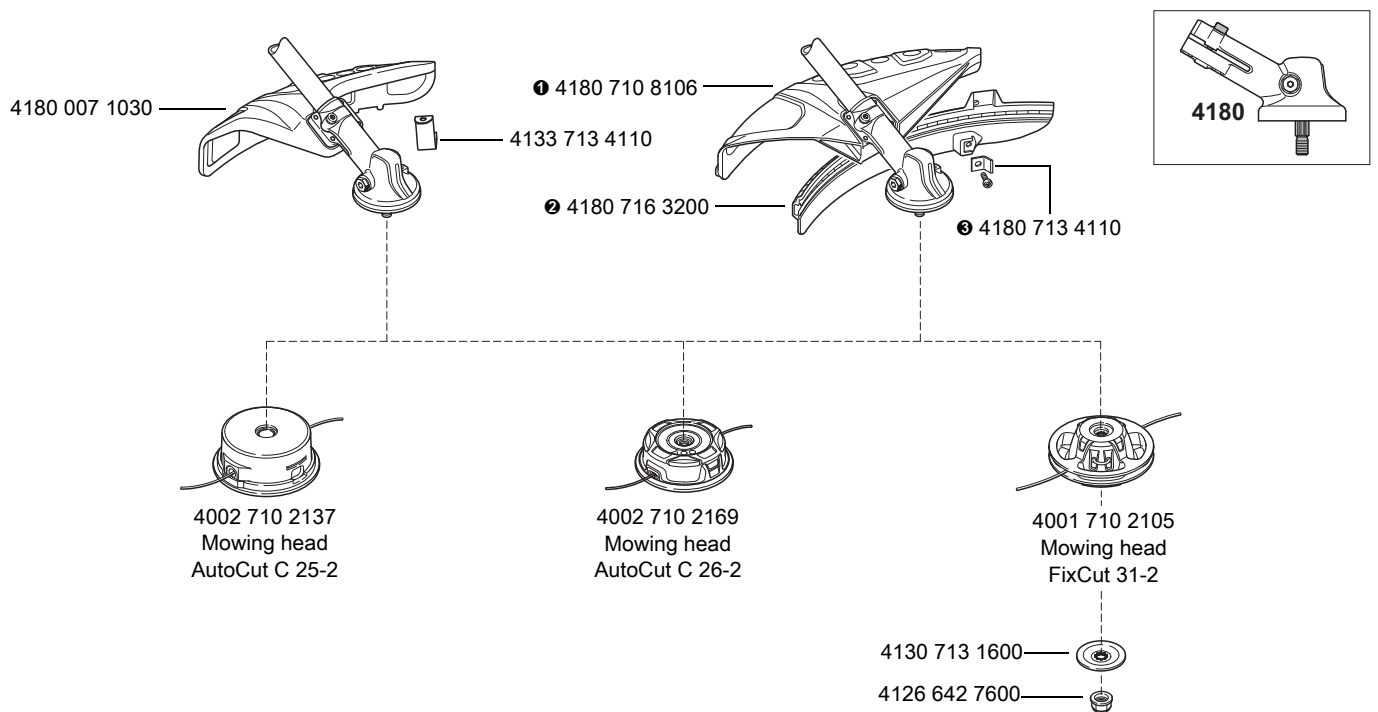

0000-GXX-5694-A0

❶ + ❷ + ❸ = 4180 007 1028

(a) from 2015 (b) from 2017

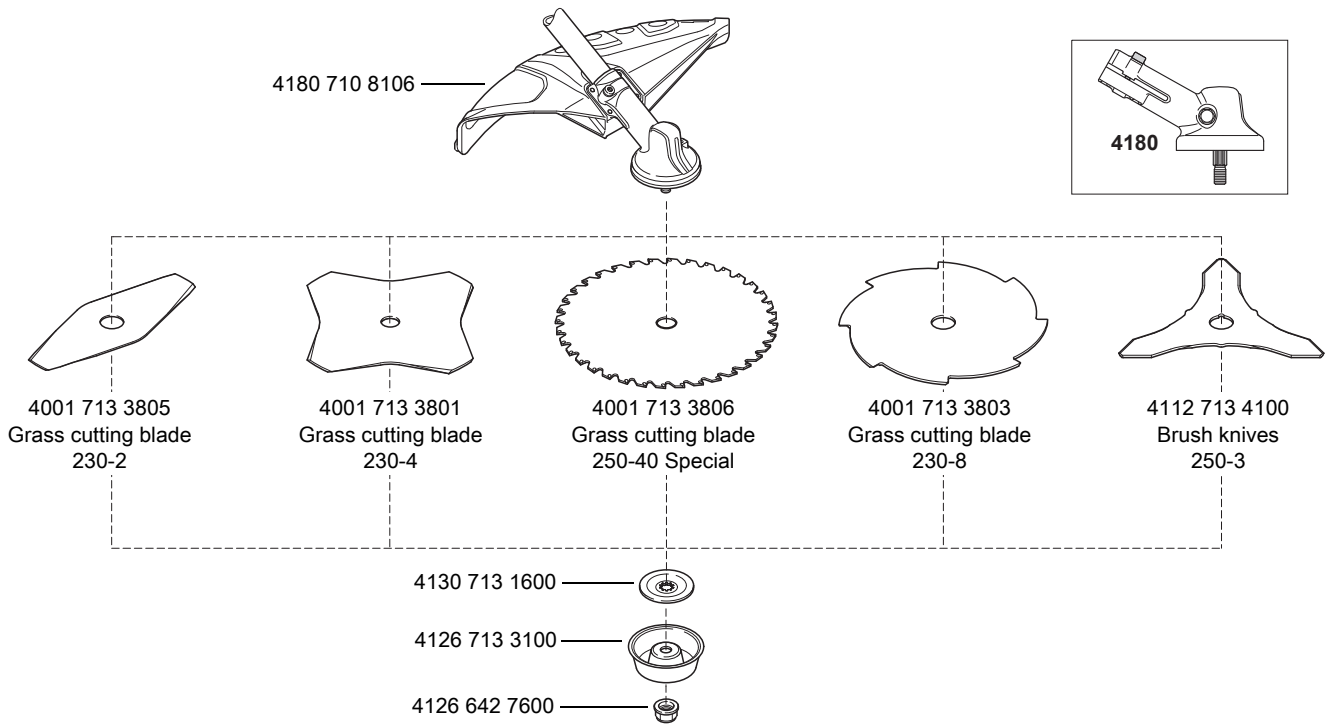

81KKT1062 KN

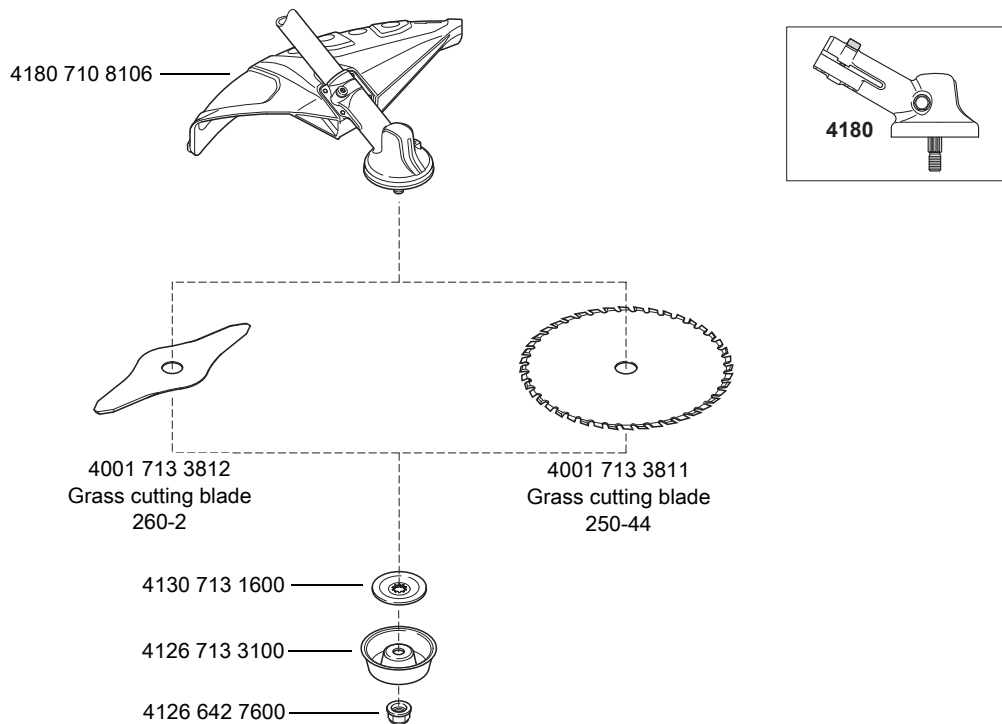

881KKT1063 KN

(a) up to 2015 (b) up to 2017

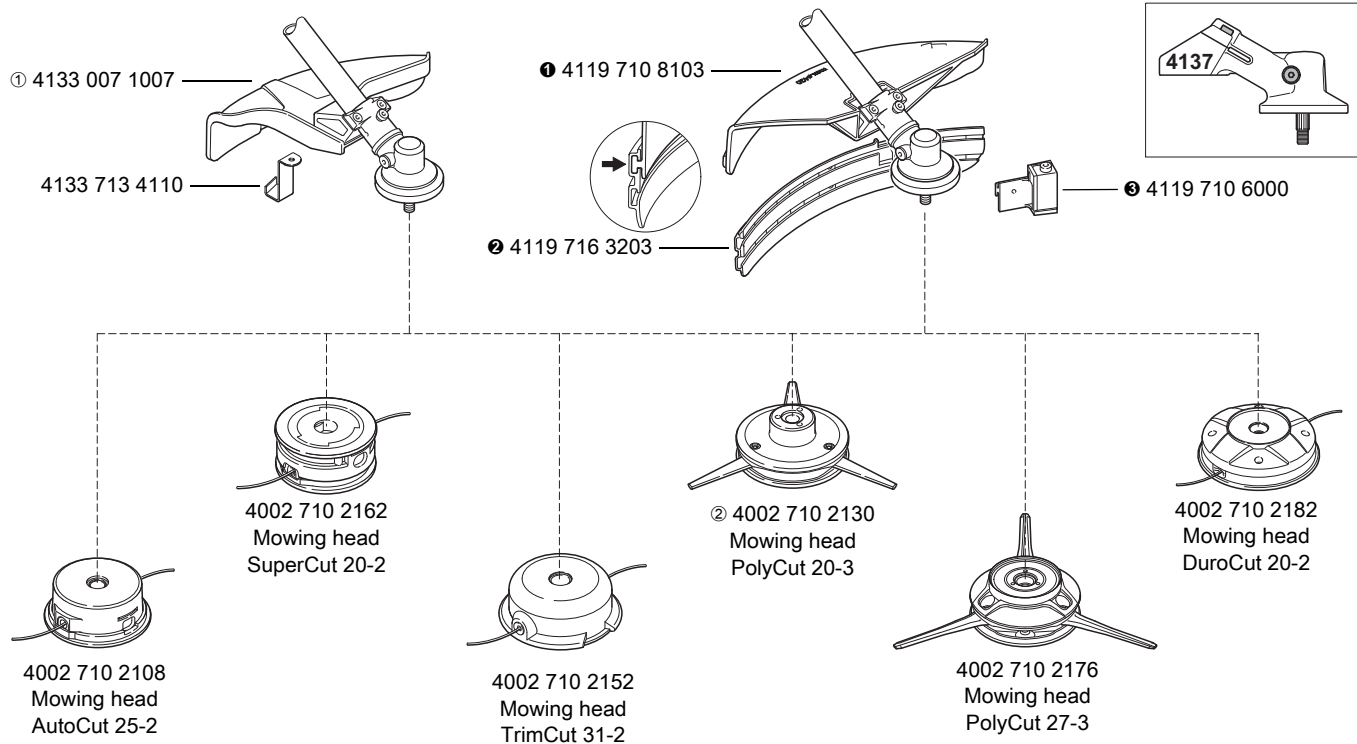

0000-GXX-5727-A0

① Approved in AUS, NZ only: 4133 007 1008

② No longer available

① + ② + ③ = 4119 007 1027

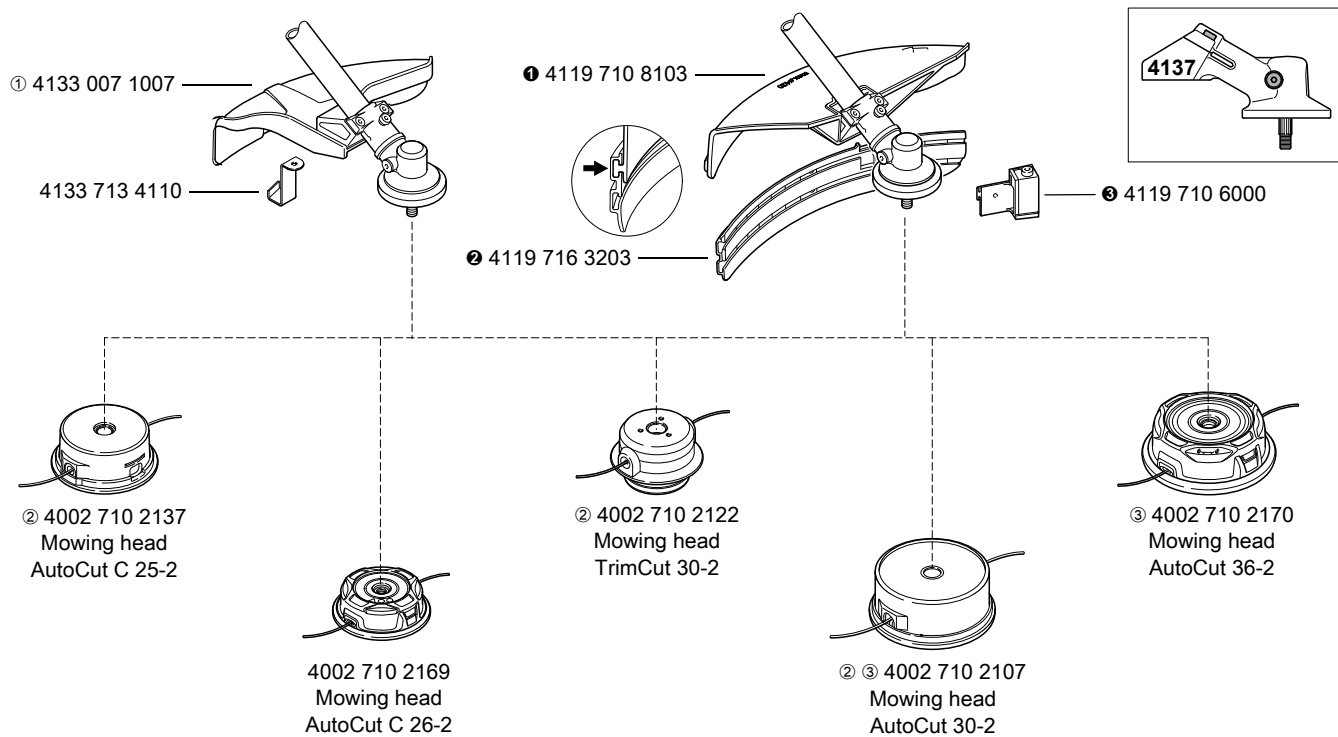

0000-GXX-3441-A0

① Approved in AUS, NZ only: 4133 007 1008

① + ② + ③ = 4119 007 1027

② No longer available

③ Not approved for FR 130 T

(a) up to 2015 (b) up to 2017

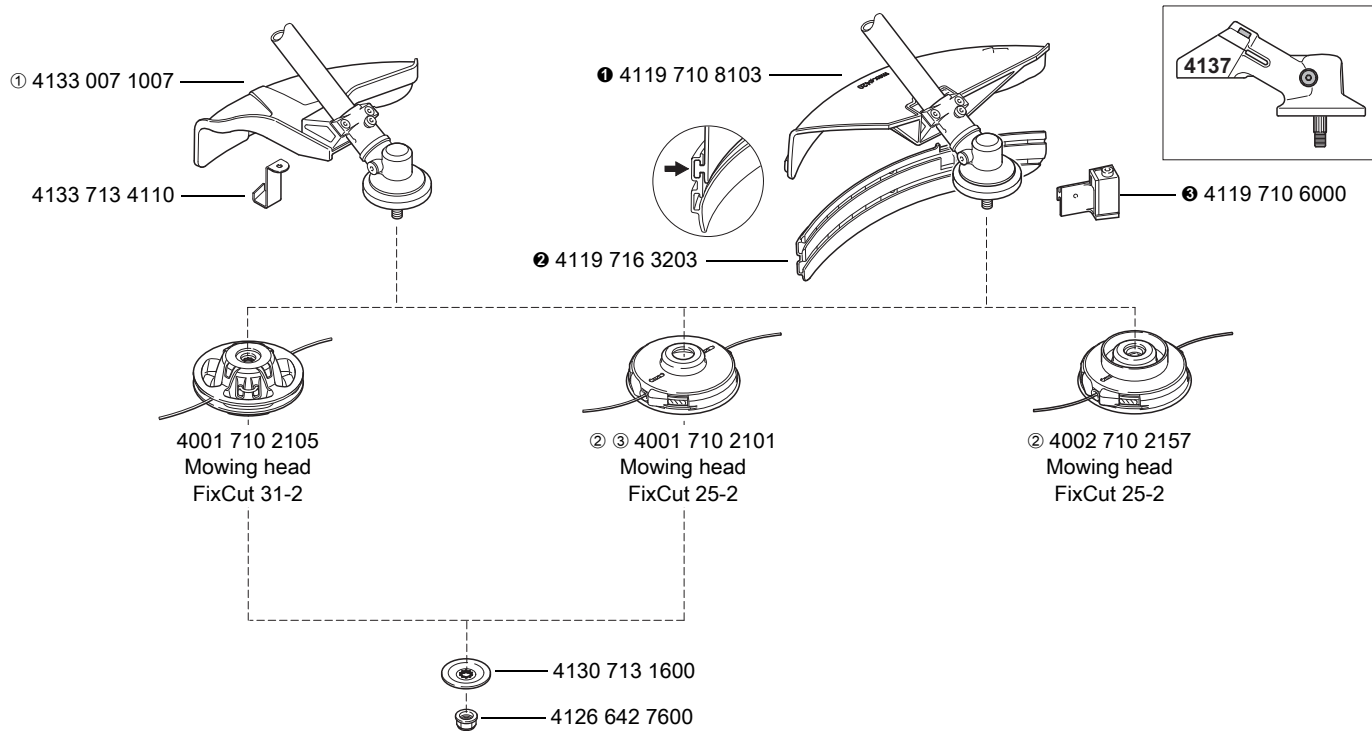

000-GXX-5795-A0

① Approved in AUS, NZ only: 4133 007 1008

① + ② + ③ = 4119 007 1027

② No longer available

③ Not approved for FR 410, 460

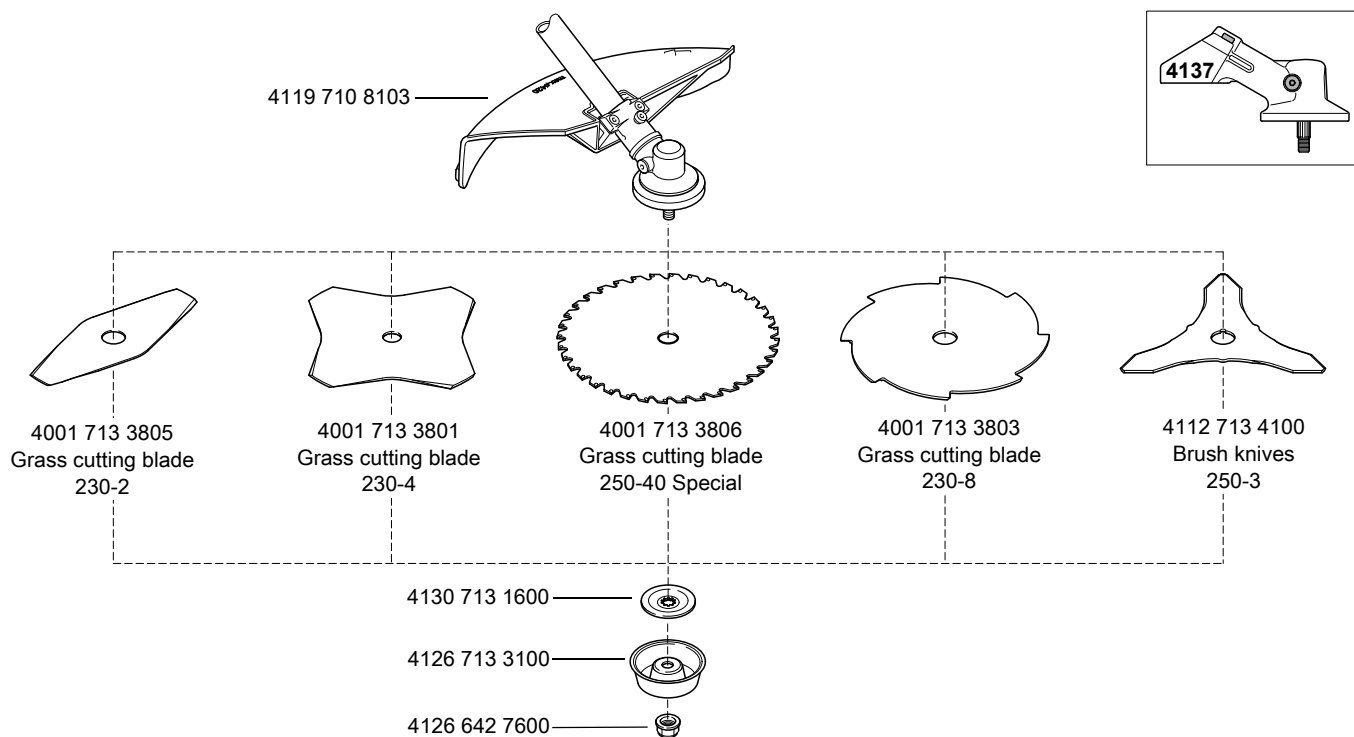

881KT1057 KN

(a) up to 2015 (b) up to 2017

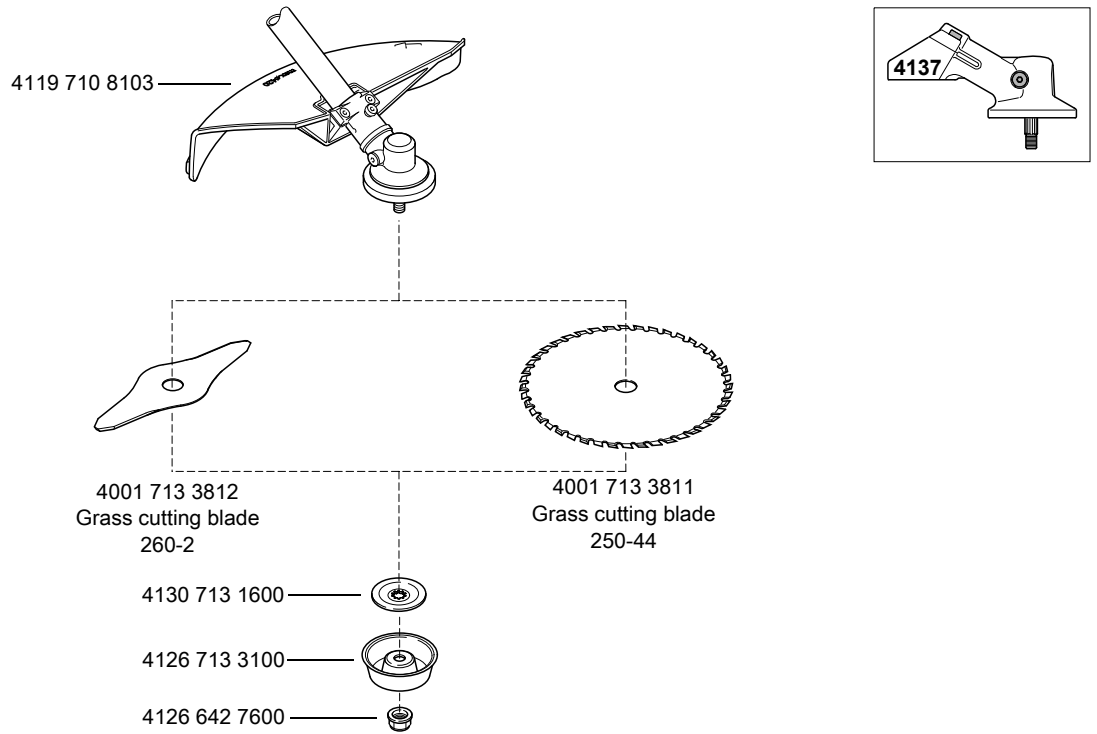

681KT1059 KN

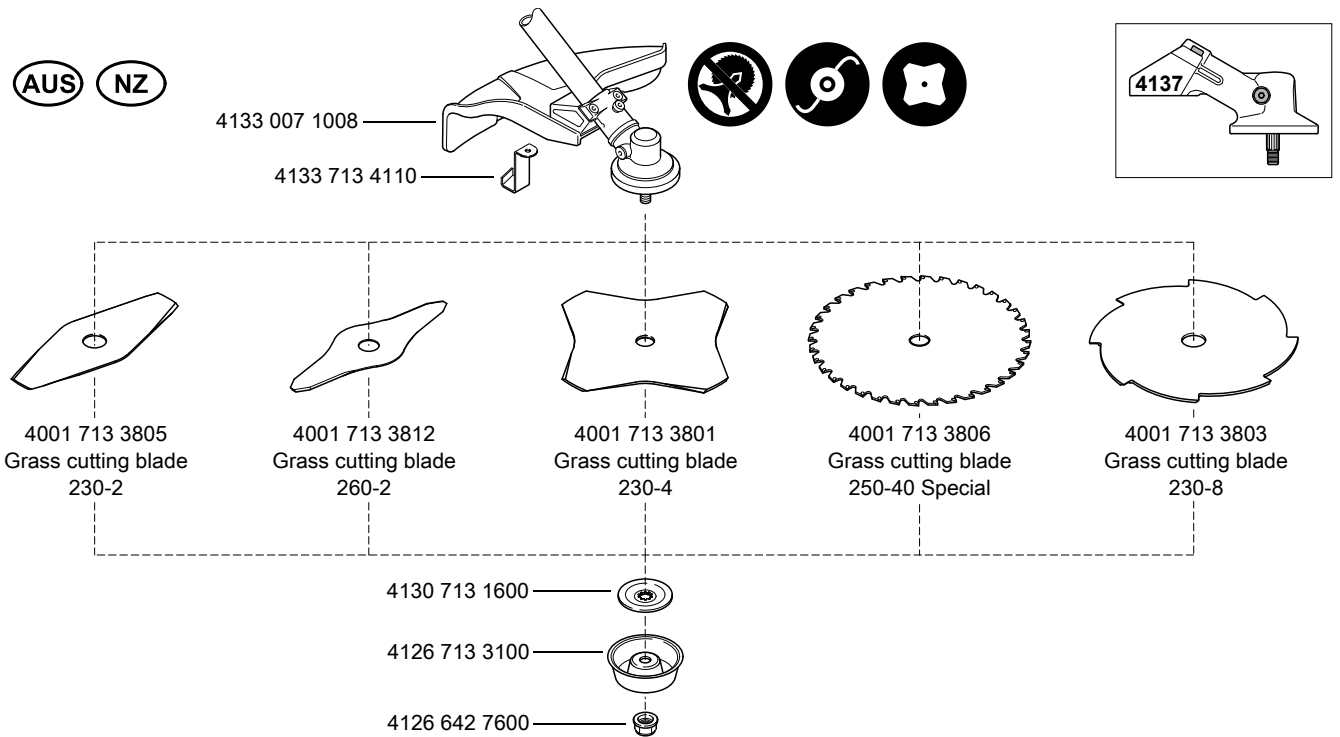

681KT1058 KN

(a) up to 2015 (b) up to 2017

AUS NZ

4133 007 1008

4133 713 4110

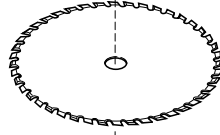
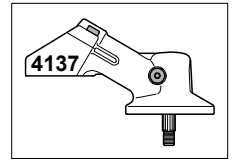
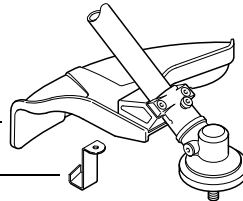

① ② 4001 713 3811
Grass cutting blade
250-44

4130 713 1600

4126 713 3100

4126 642 7600



681KT1124 KN

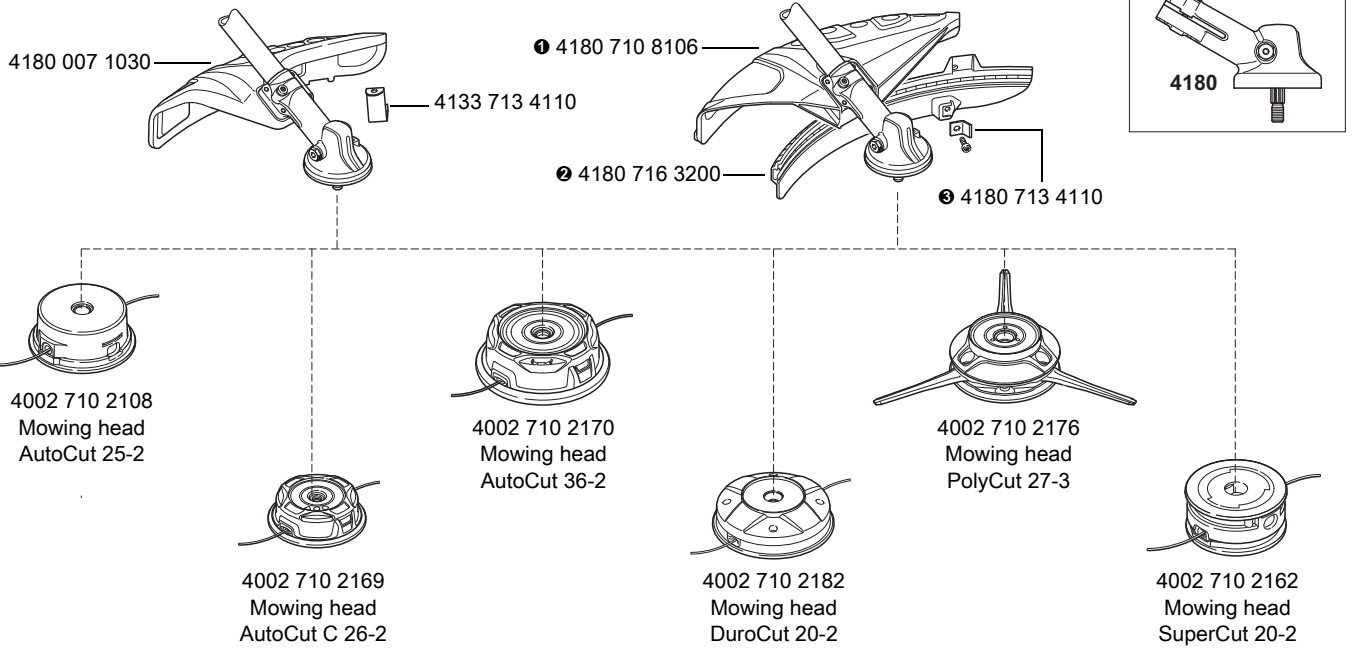

0000-GX

1 + 2 + 3 = 4180 007 1028

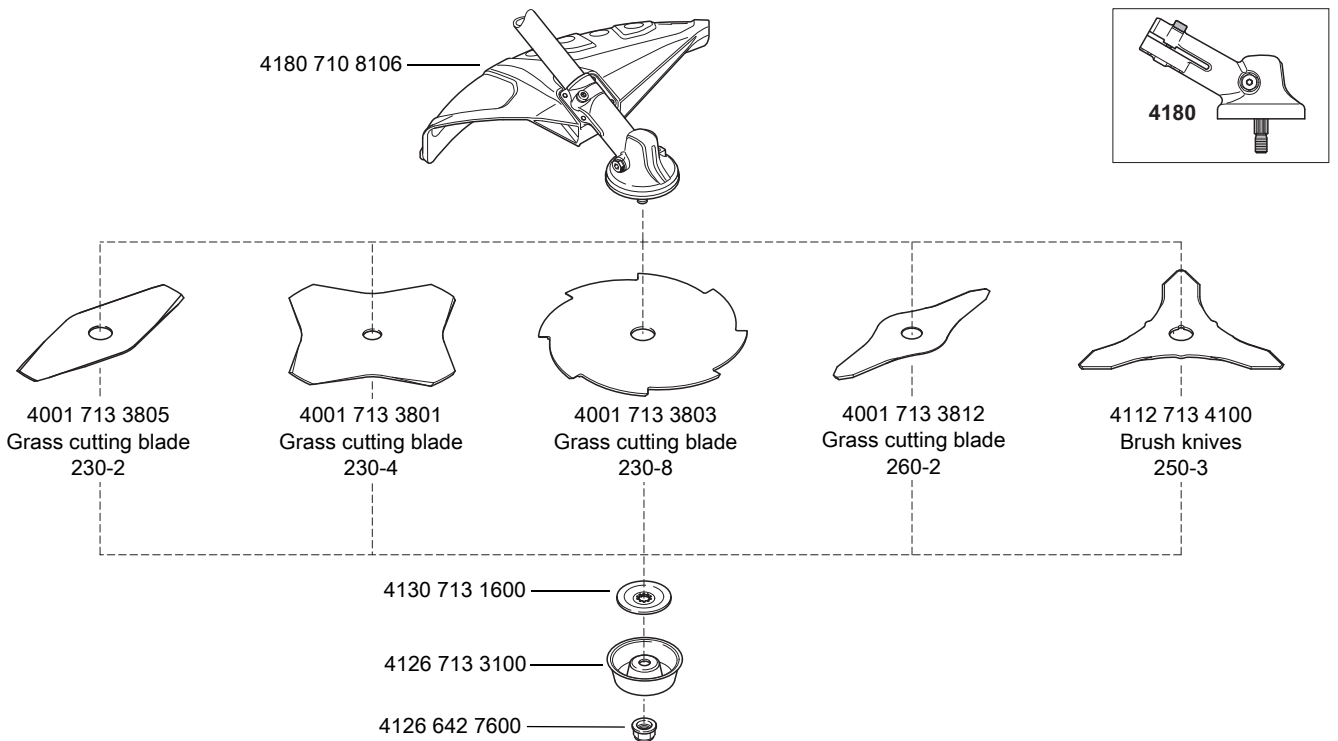

0000-GXX-8231-A0

(a) up to 2014

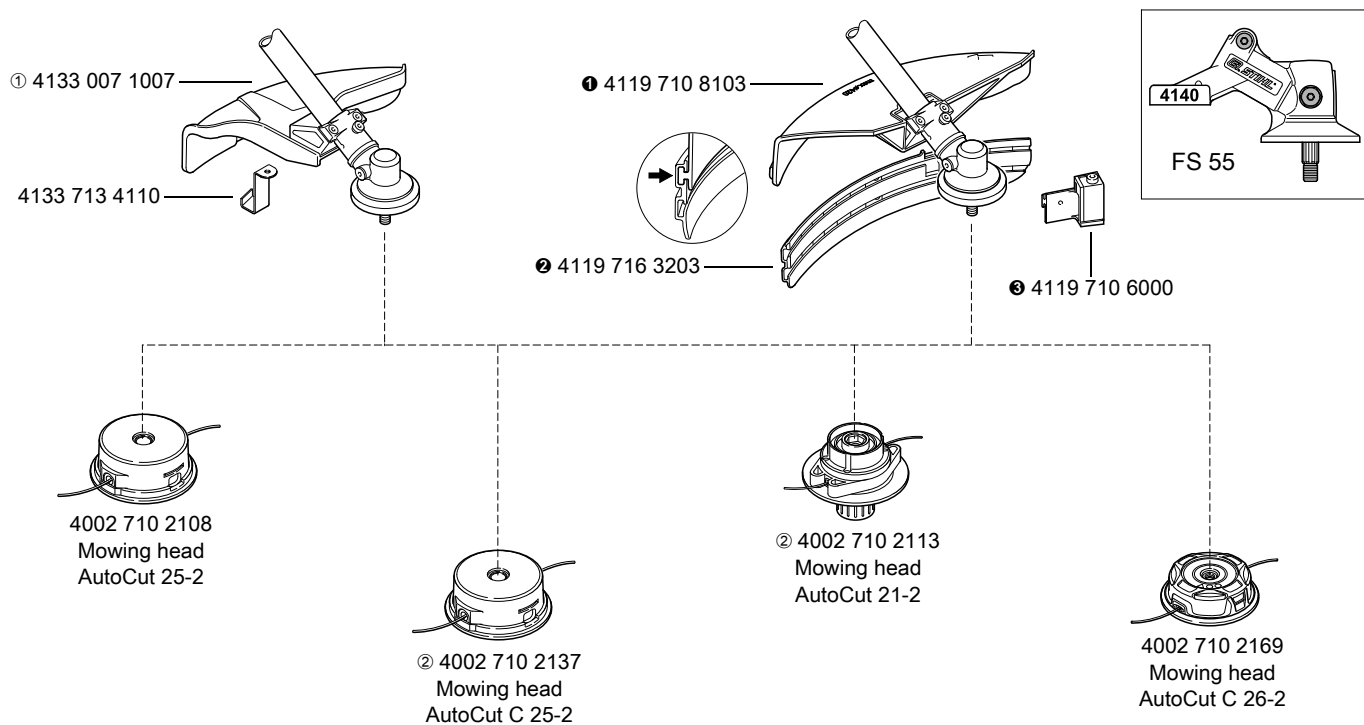

0000-GXX-3442-A0

① Approved in AUS, NZ only: 4133 007 1008

② No longer available

① + ② + ③ = 4119 007 1027

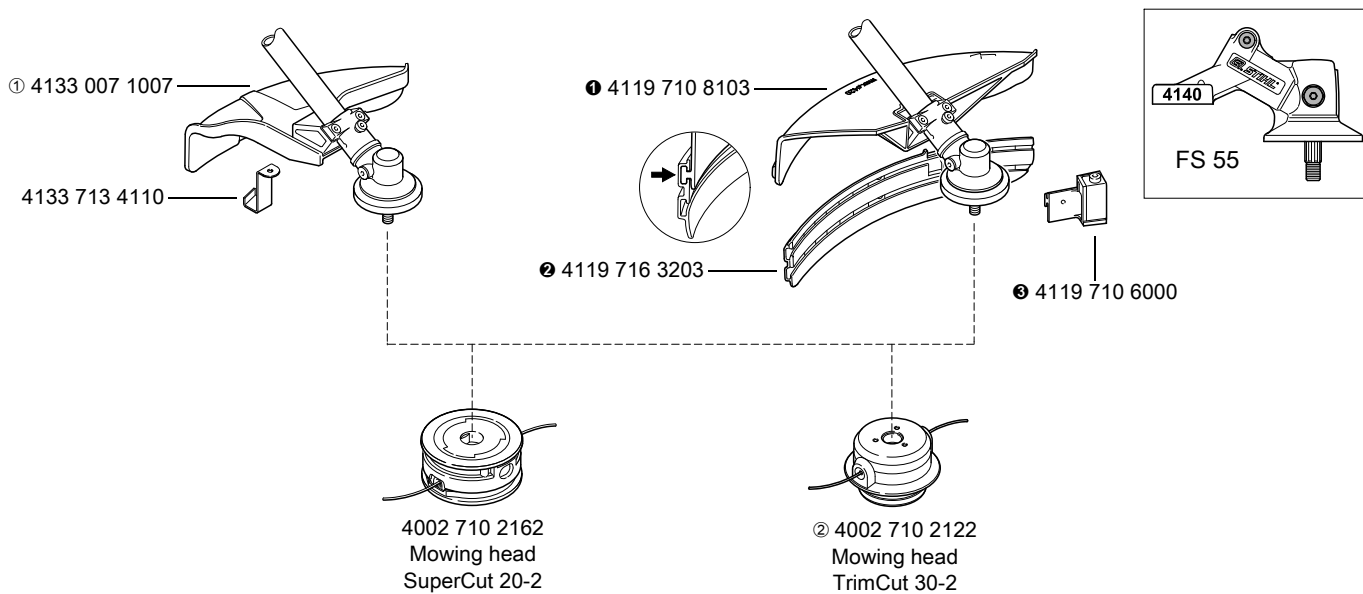

0000-GXX-3443-A0

① Approved in AUS, NZ only: 4133 007 1008

② No longer available

① + ② + ③ = 4119 007 1027

(a) up to 2014

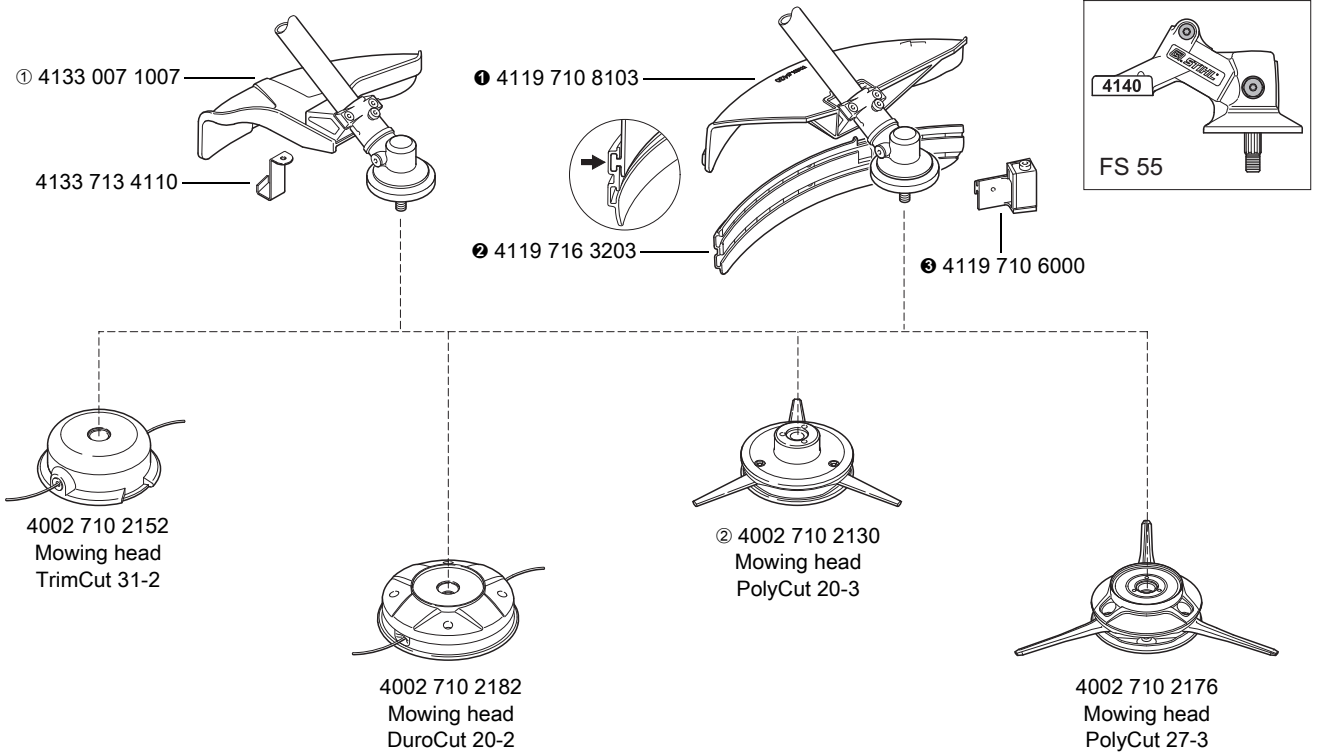

0000-GXX-5728-A0

① Approved in AUS, NZ only: 4133 007 1008

② No longer available

① + ② + ③ = 4119 007 1027

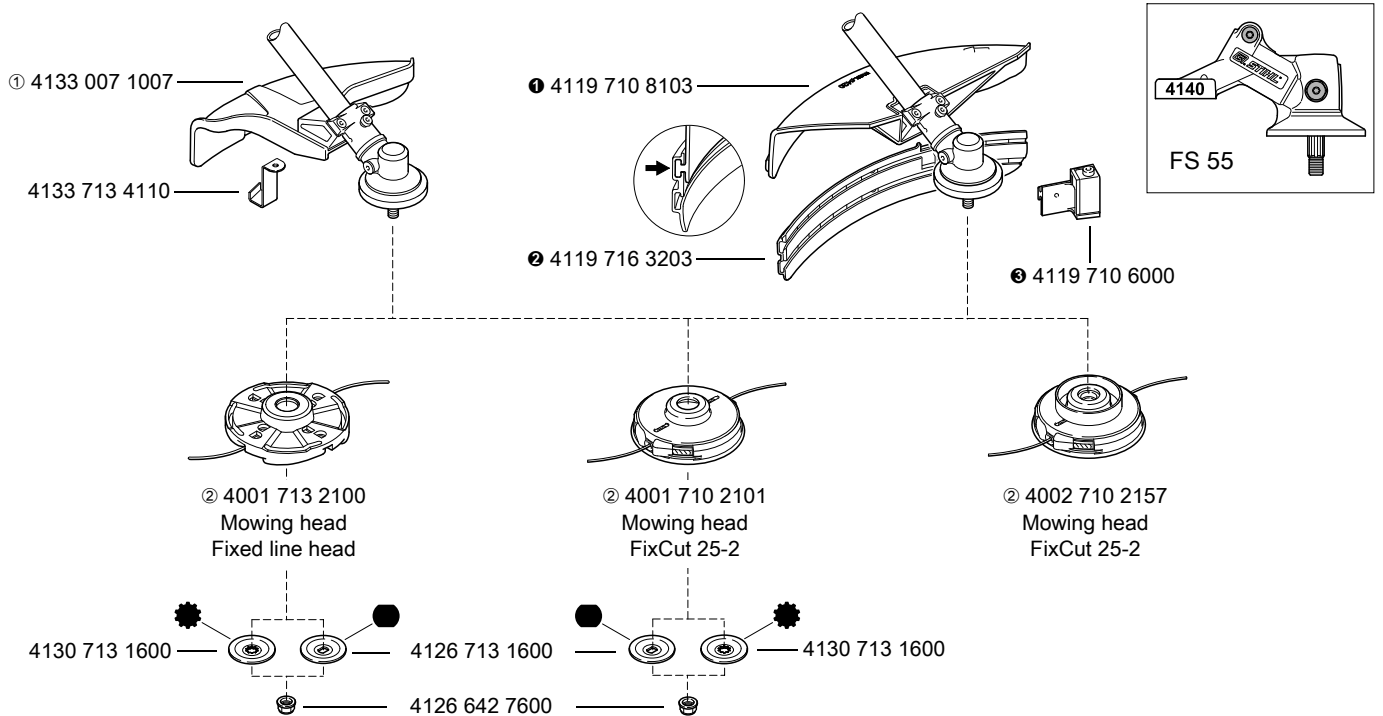

381KT792 KN

① Approved in AUS, NZ only: 4133 007 1008

② No longer available

① + ② + ③ = 4119 007 1027

(a) up to 2014

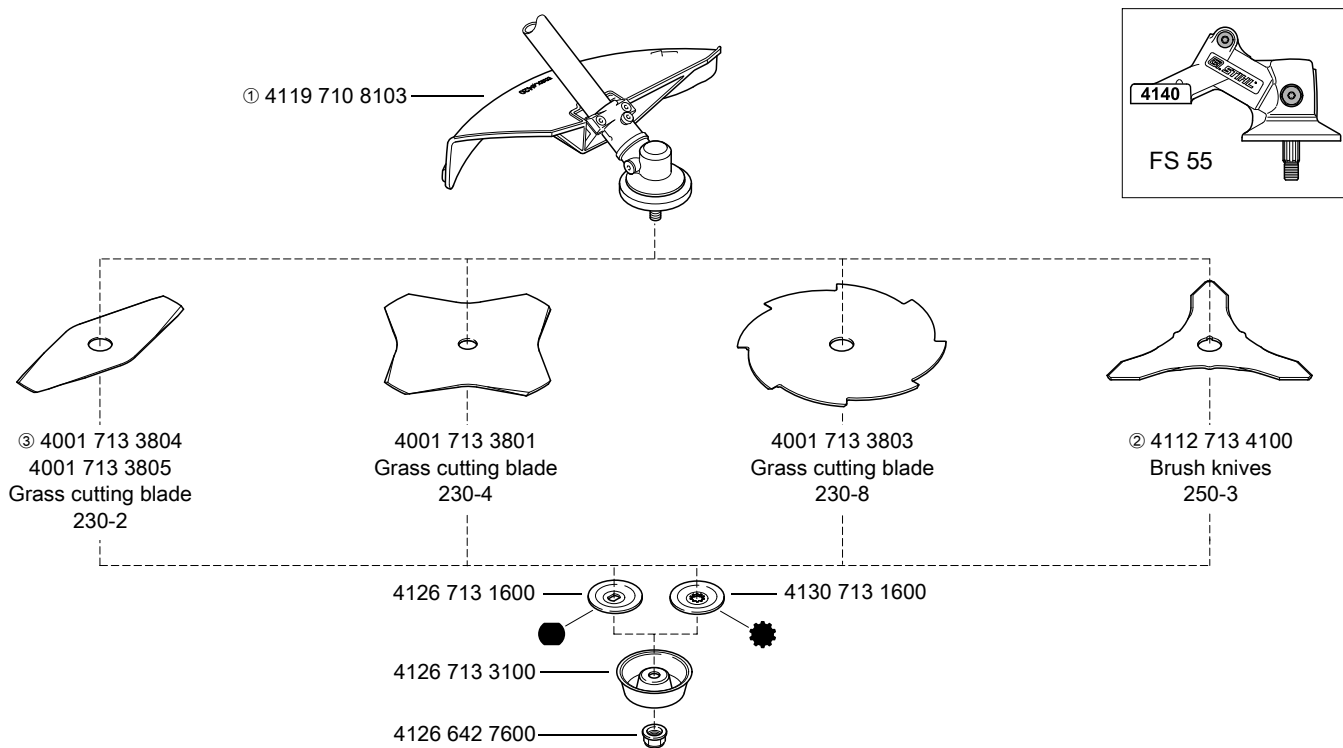

681KT510 KN

① Deflector for AUS, NZ see illustration marked "AUS, NZ"

② Not approved for FS 44, 55, 55 T

③ No longer available

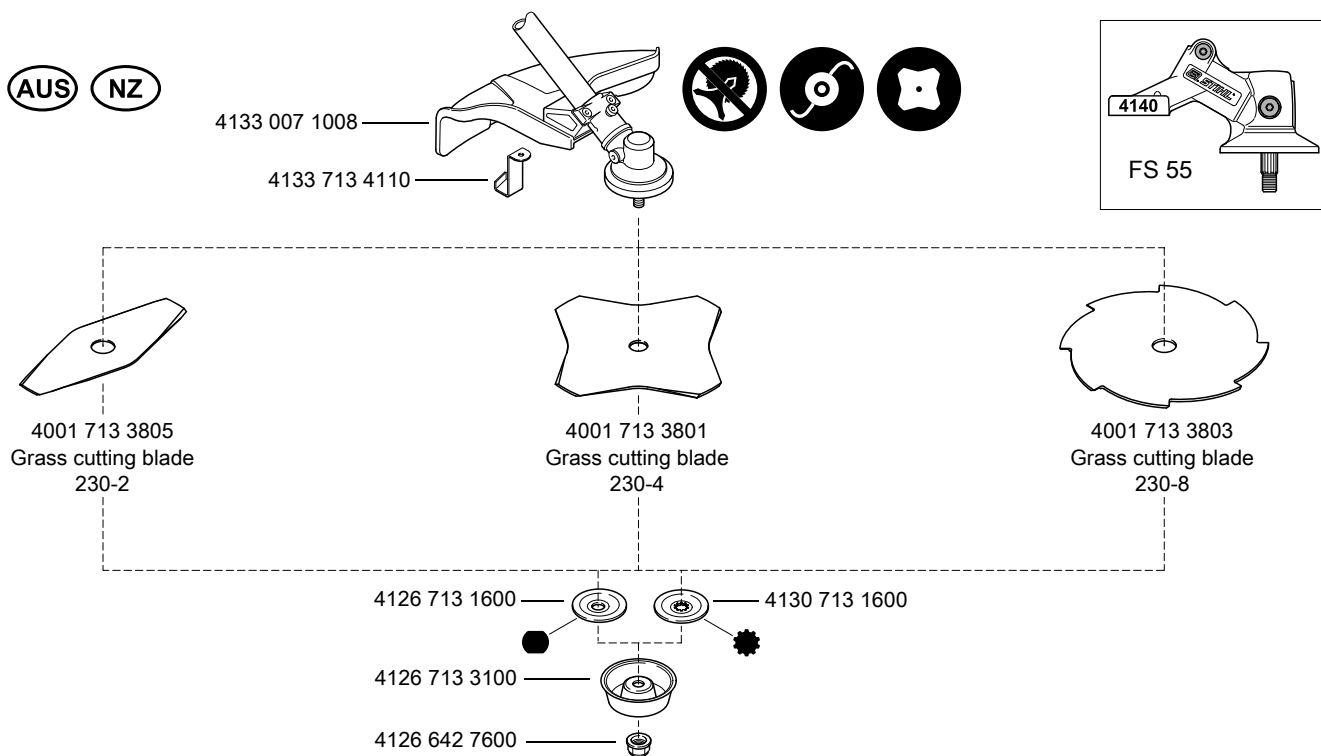

381KT862 KN

(a) up to 1999

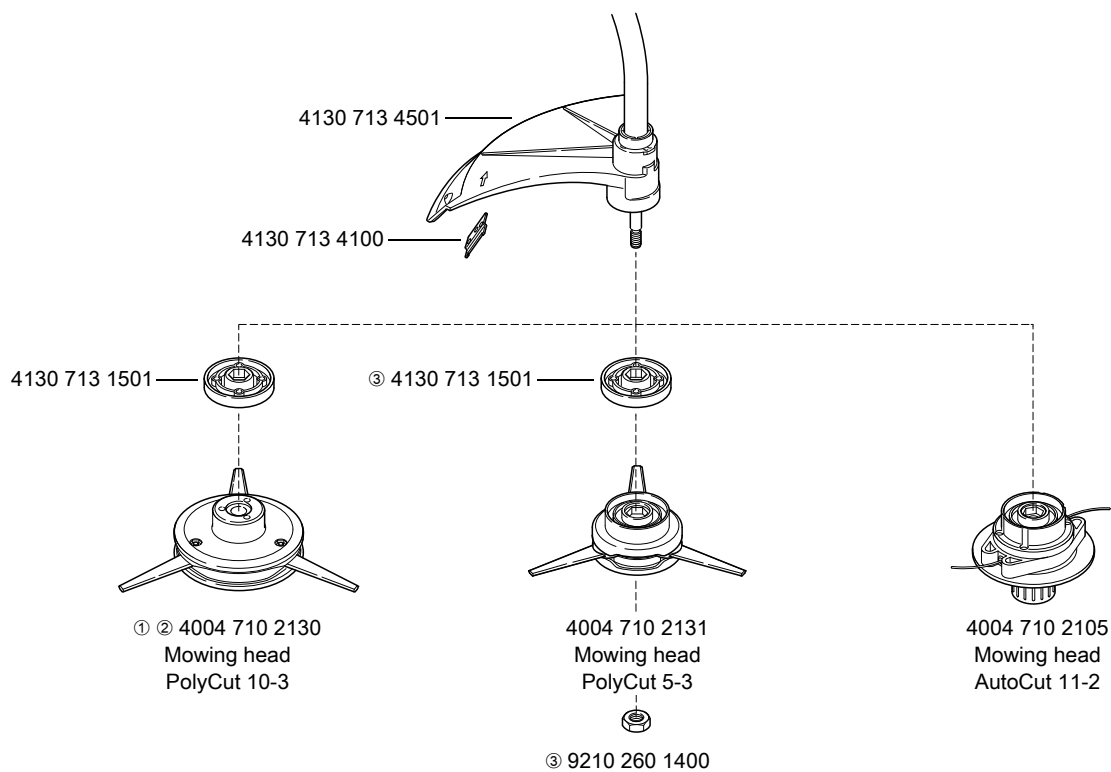

681KT567 KN

① Not approved for FS 36

② No longer available

③ Part supplied with mowing head

(a) from 2008

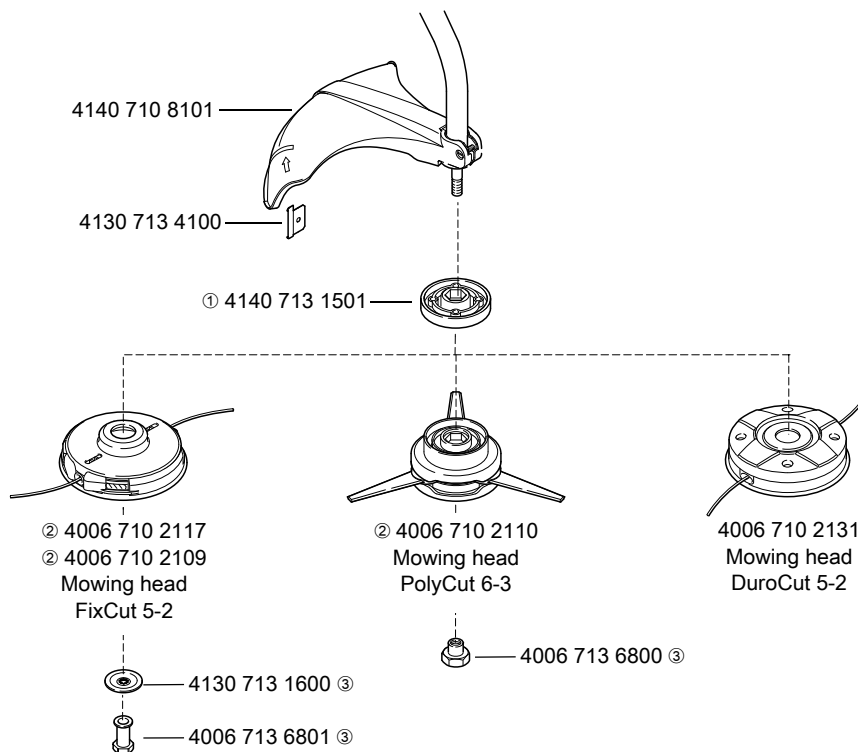

0000-GXX-8898-A0

① Part supplied with mowing head

② No longer available

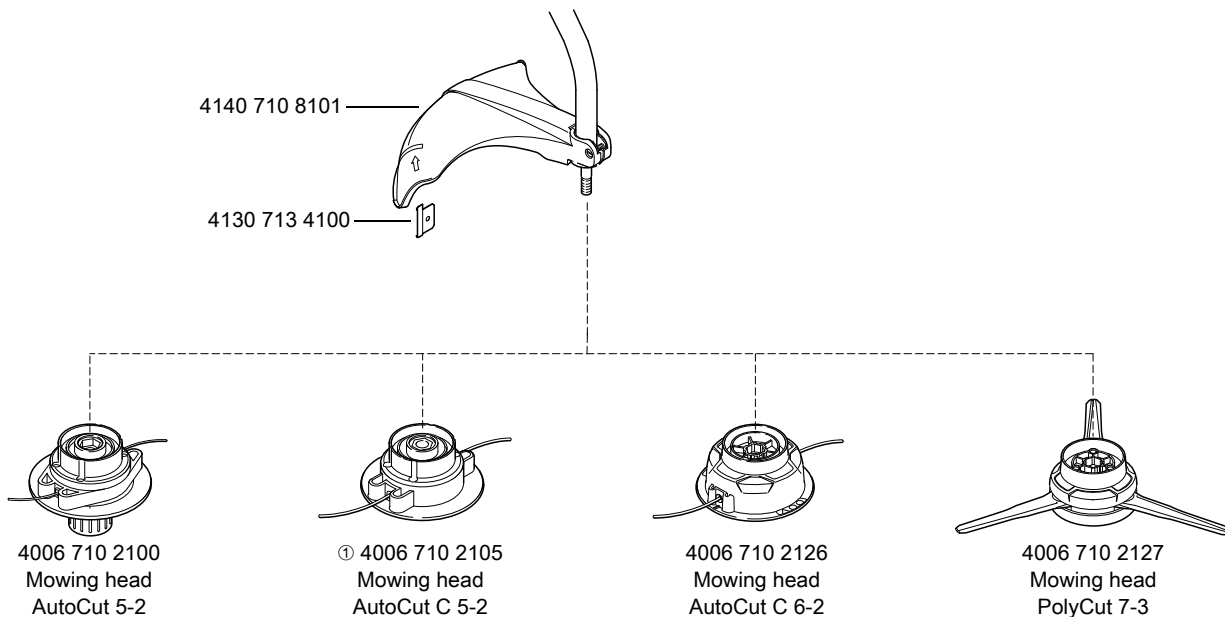

0000-GXX-8899-A0

① No longer available

(a) from 2008

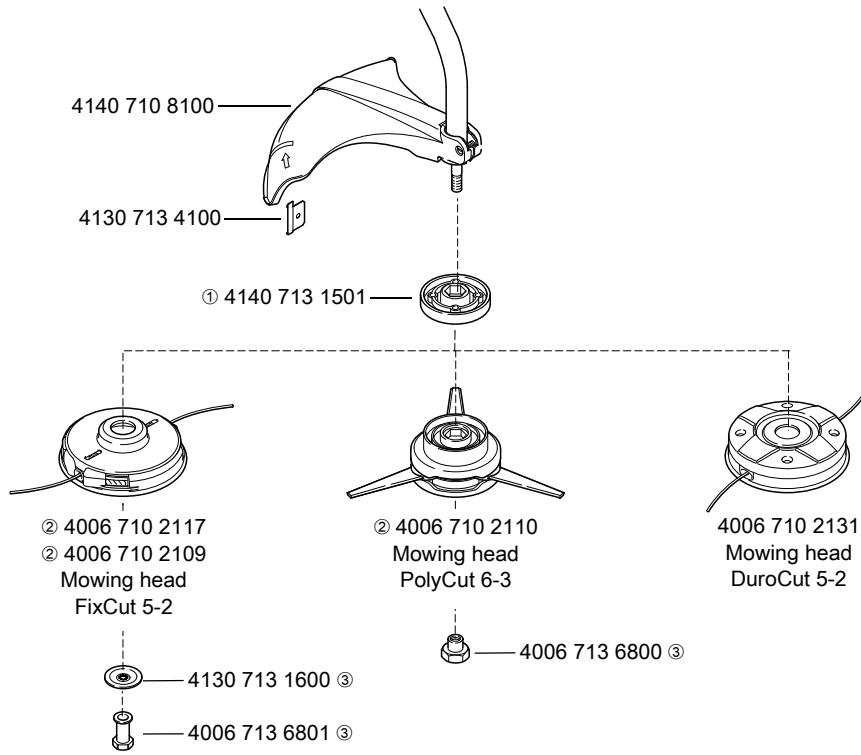

0000-GXX-8900-A0

① Part supplied with PolyCut 6-3 and FixCut 5-2 mowing heads

② No longer available

③ Part supplied with mowing head

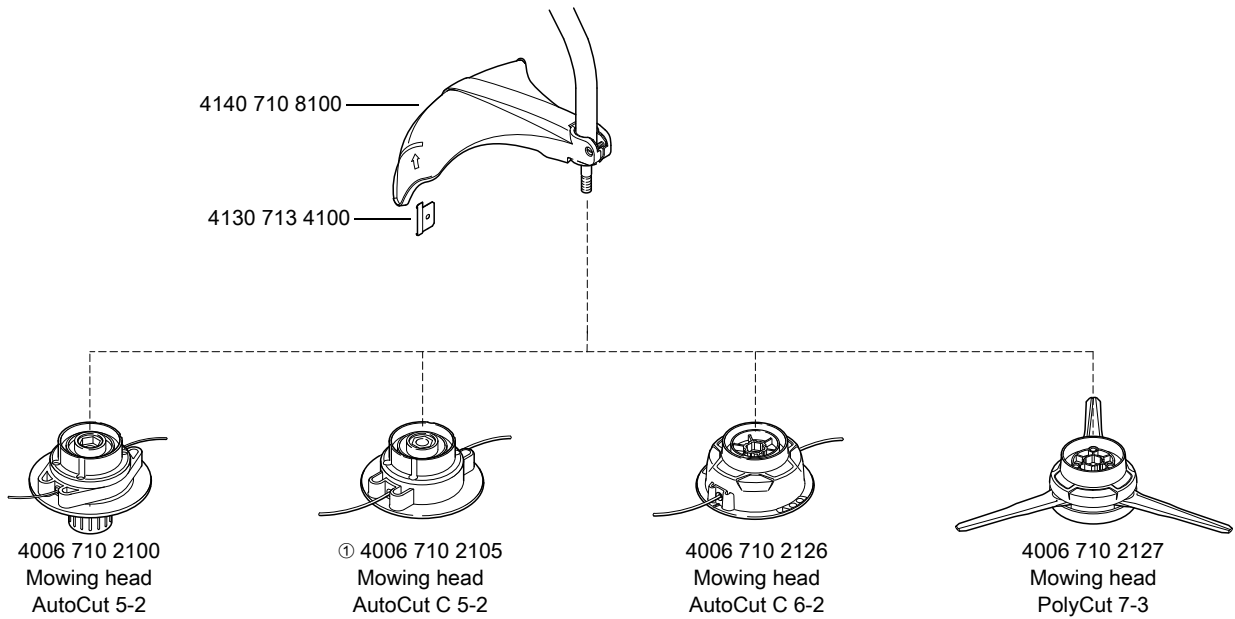

0000-GXX-8901-A0

① No longer available

(a) up to 1984 (b) up to 1995

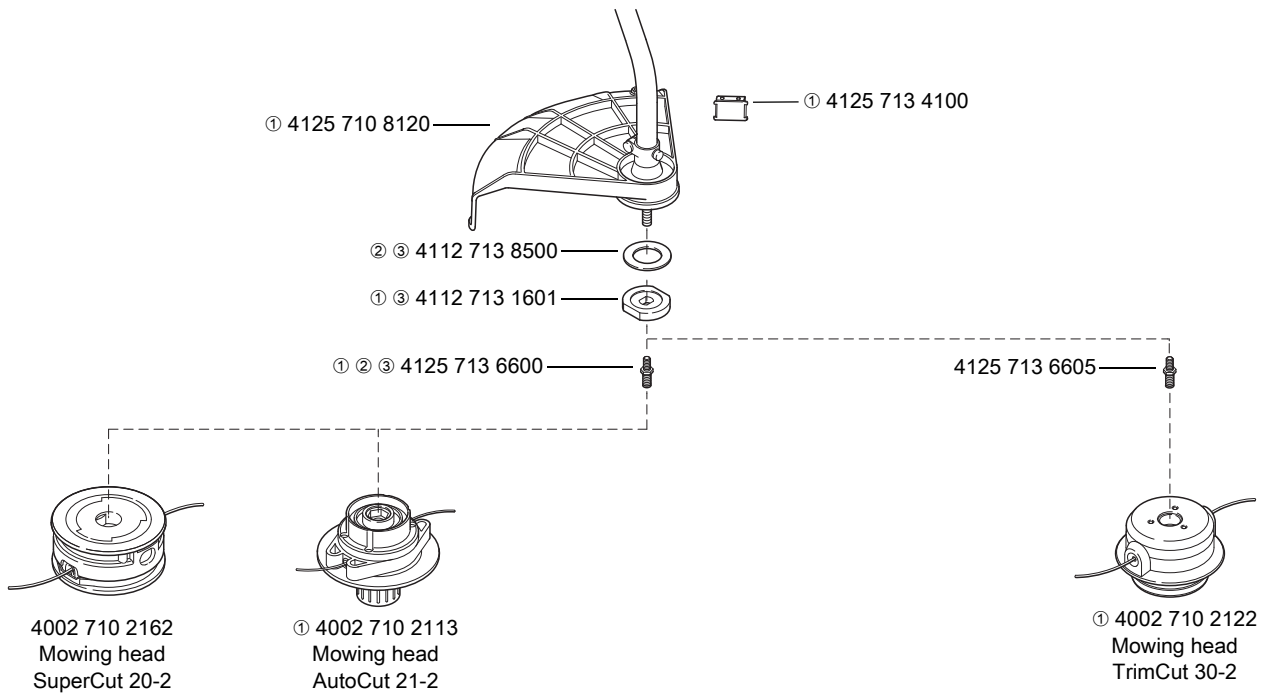

681KT1560-A1

- ① No longer available
- ② Special accessories
- ③ Only required for FS 50, 51

(a) as of 2014 (b) as of 2008

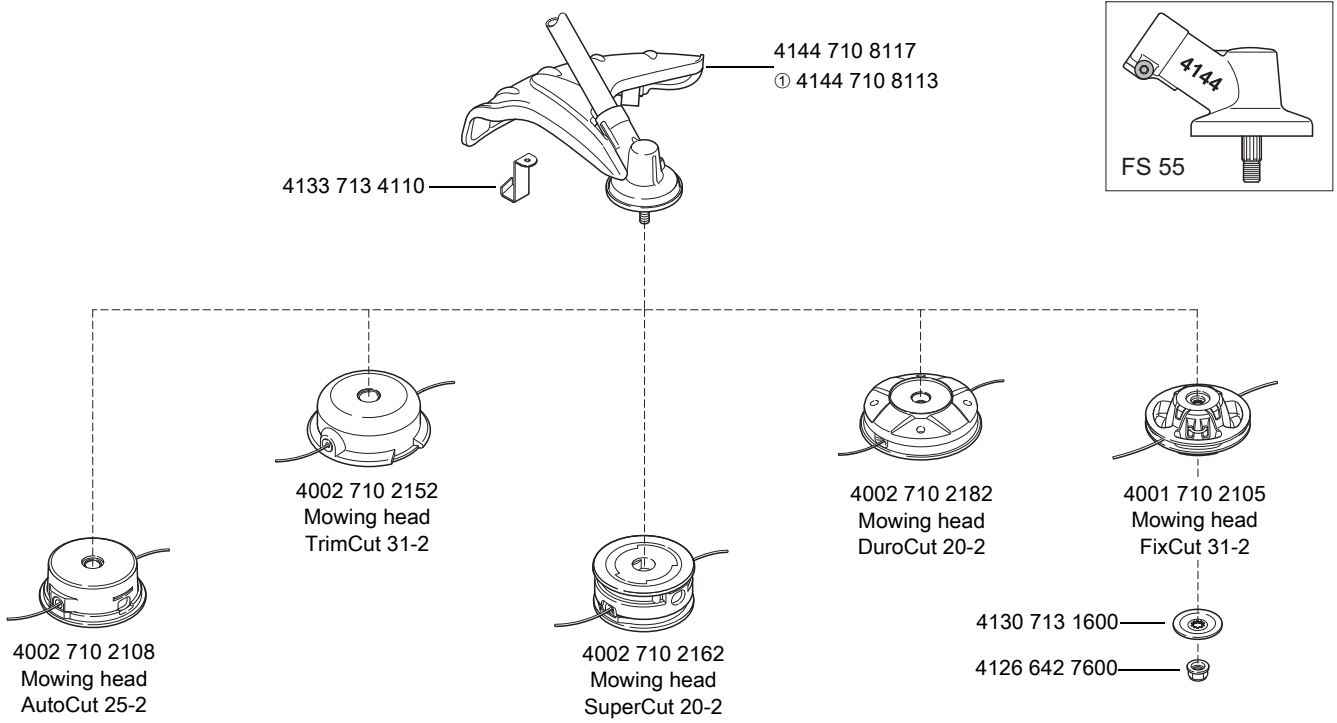

0000-GXX-5686-A1

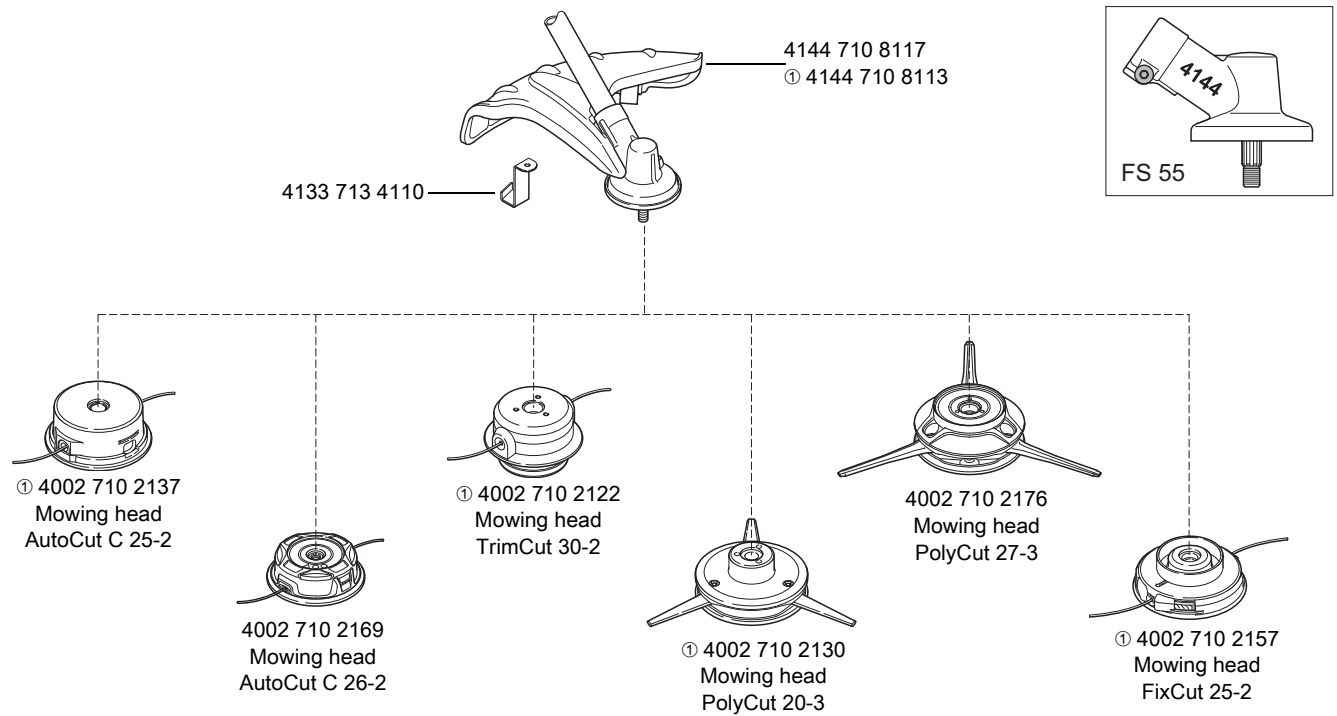

0000-GXX-5731-A0

① No longer available

(a) as of 2014 (b) as of 2008

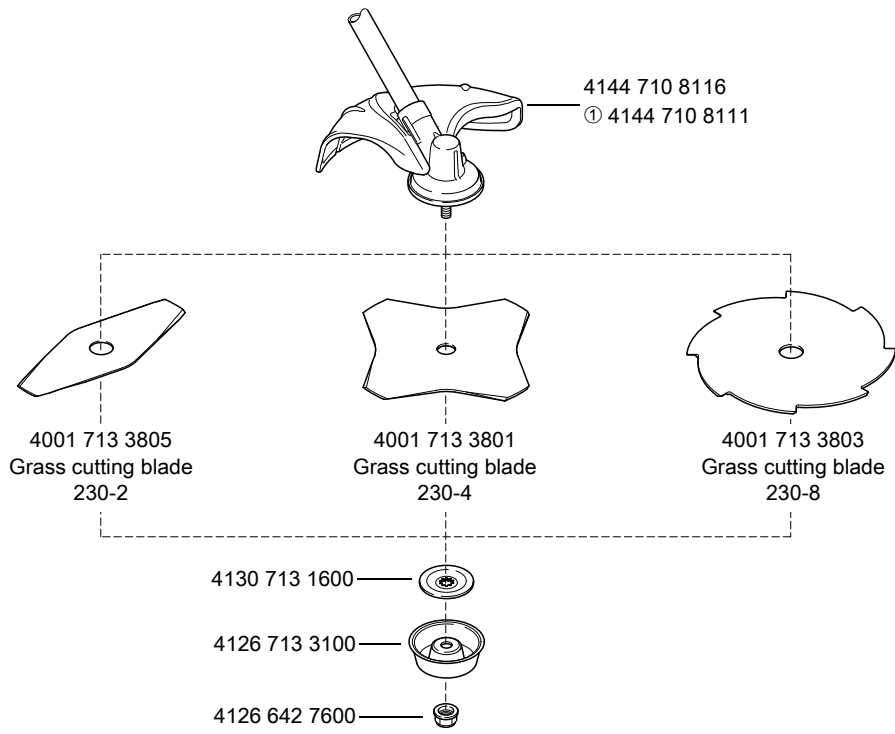

681K794 KN

① No longer available

(a) up to 1986

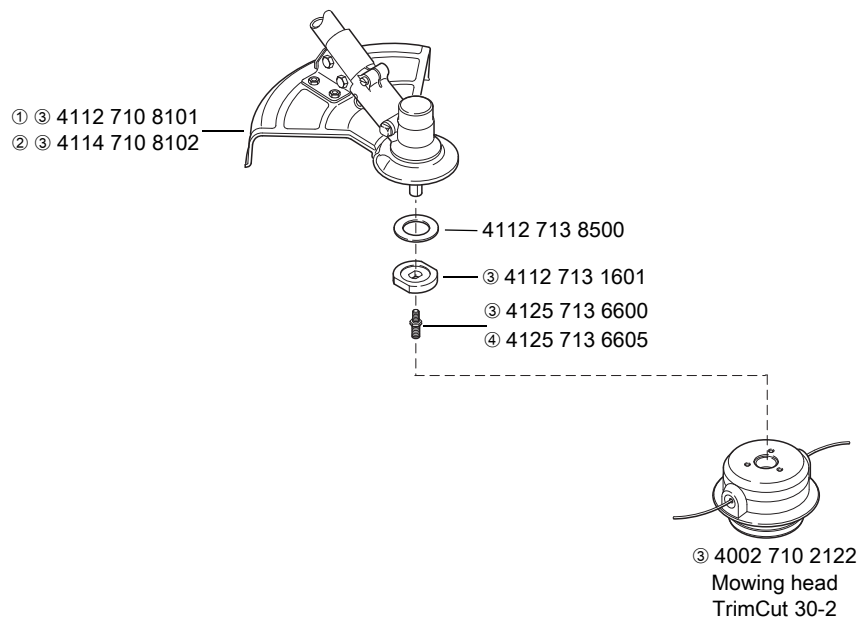

681KT949-A1

① For FS 80, 90

④ Special accessory for TrimCut 30-2

② For FS 65

③ No longer available

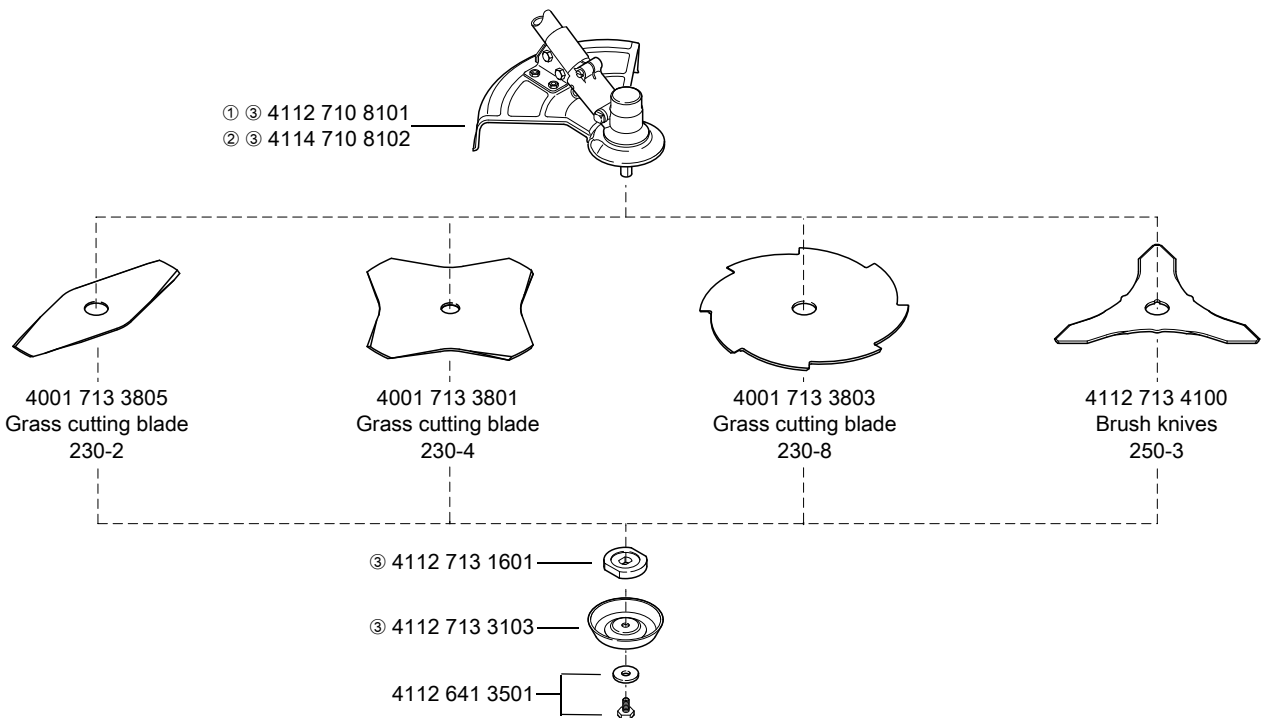

681KT515 KN

① For FS 80, 90

② For FS 65

③ No longer available

(a) up to 1986

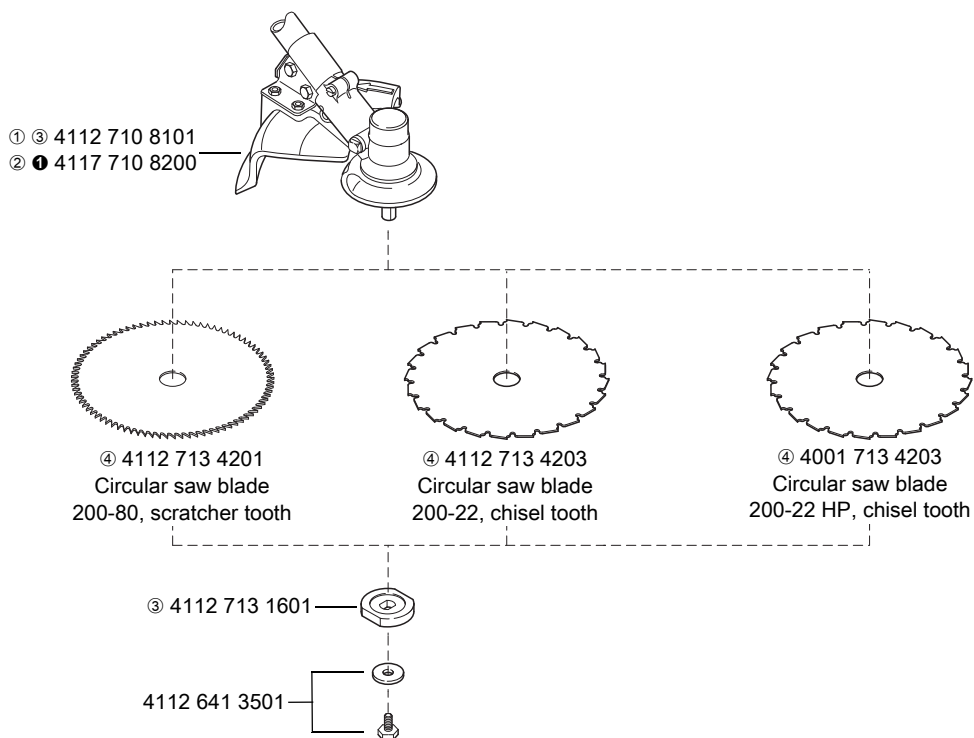

681KT516-A1

① For FS 80, 90

① + Transport guard = 4126 007 1002

② For FS 65, 90

③ No longer available

④ Not approved on brushcutters with loop handle

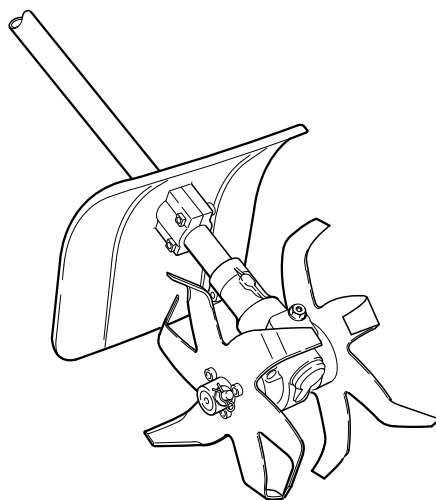

①②③ 4600 710 1500
Cultivator BC 30

681KT517 KN

① For FS 65, FS 80 from machine No. X 5 168 100, FS 90

② No longer available

③ Not approved on brushcutters with loop handle

(a) from 2017

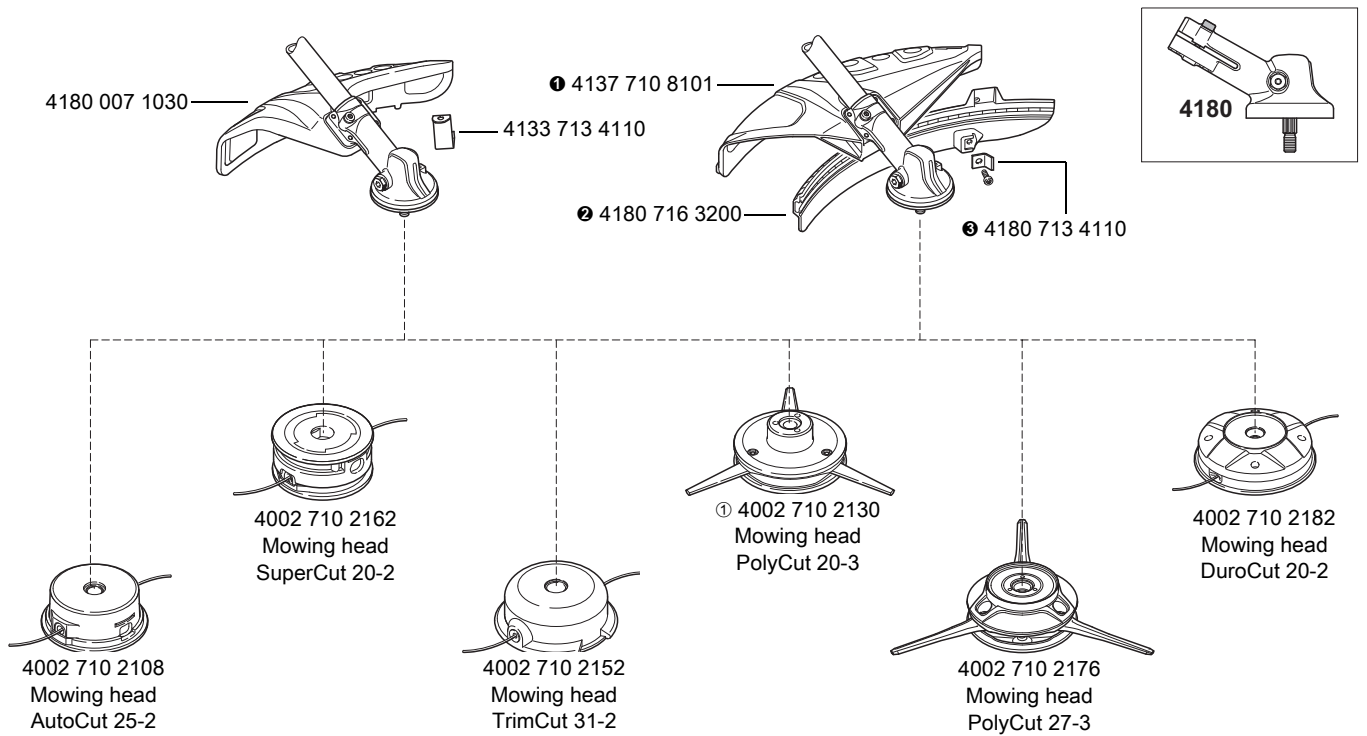

0000-GXX-5733-A0

① No longer available

① + ② + ③ = 4137 007 1040

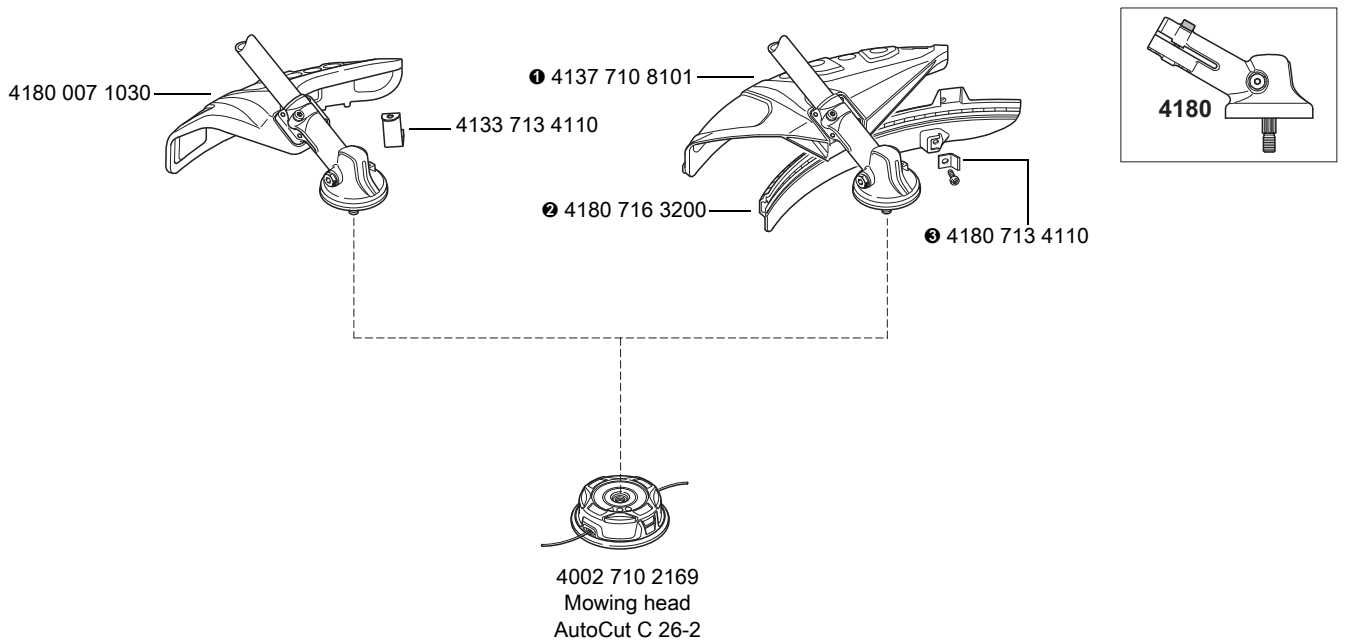

0000-GXX-5699-A0

① + ② + ③ = 4137 007 1040

(a) from 2017

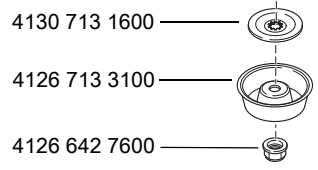
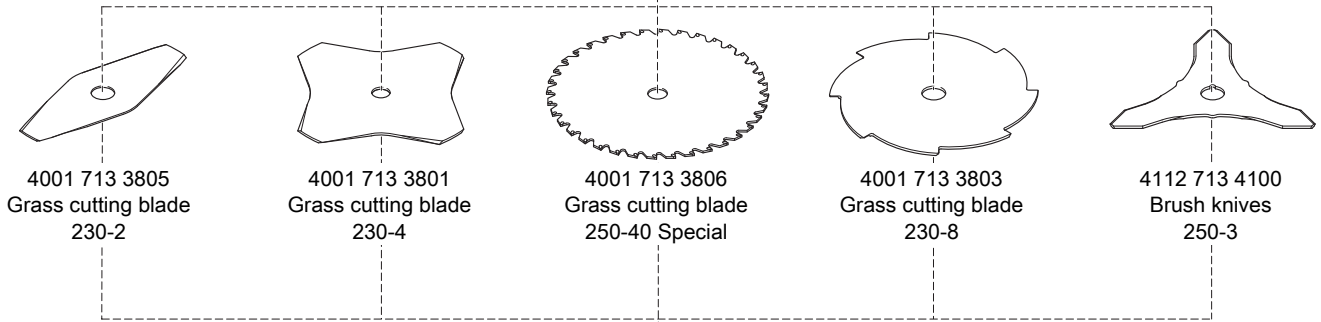
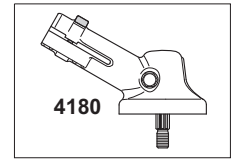
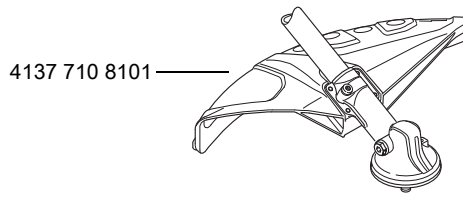

0000-GXX-4207-A0

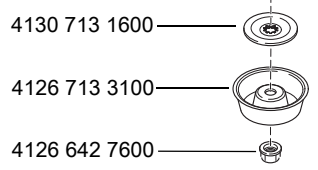
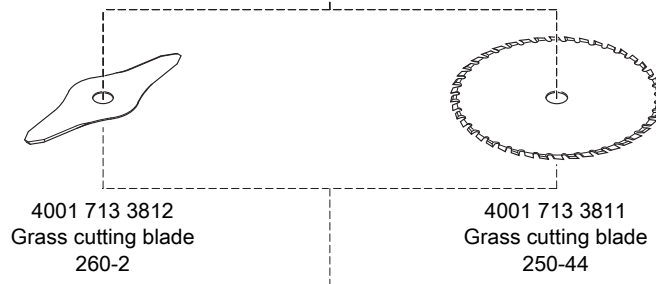
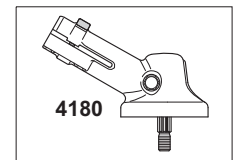
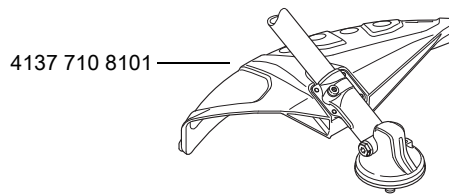

0000-GXX-4208-A0

(a) from 2017

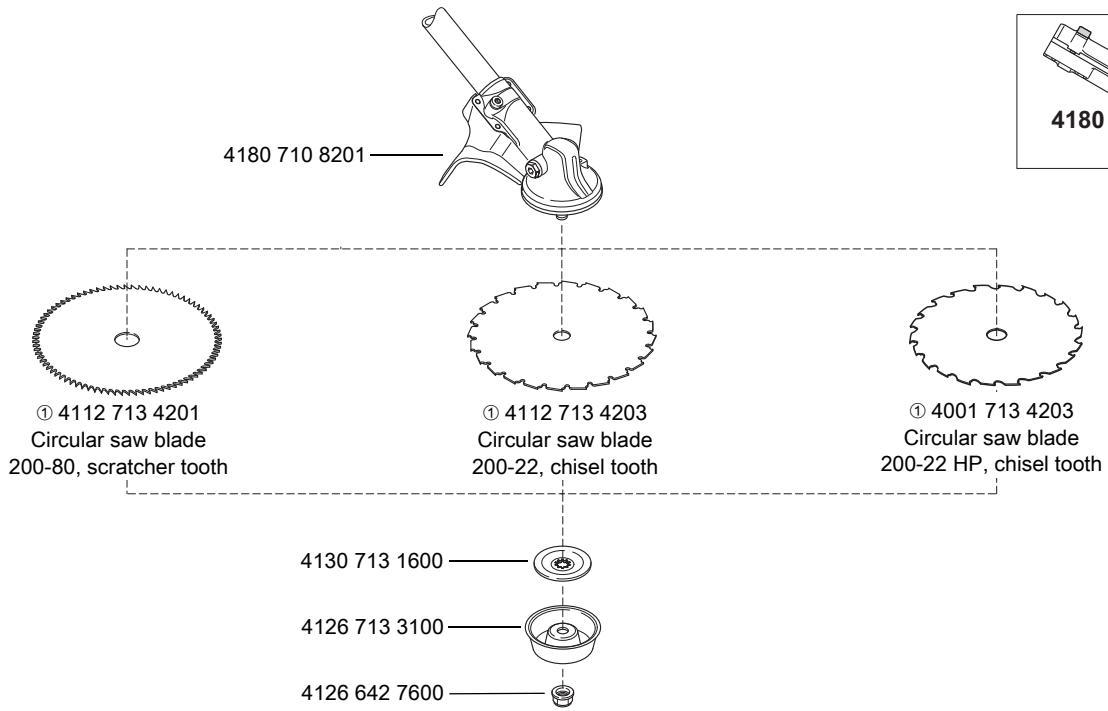

0000-GXX-5700-A0

① Not approved on brushcutters with loop handle

(a) from 1996 up to 2017 (b) from 2017 (c) from 2006 (d) FS 100 RX: Page 59

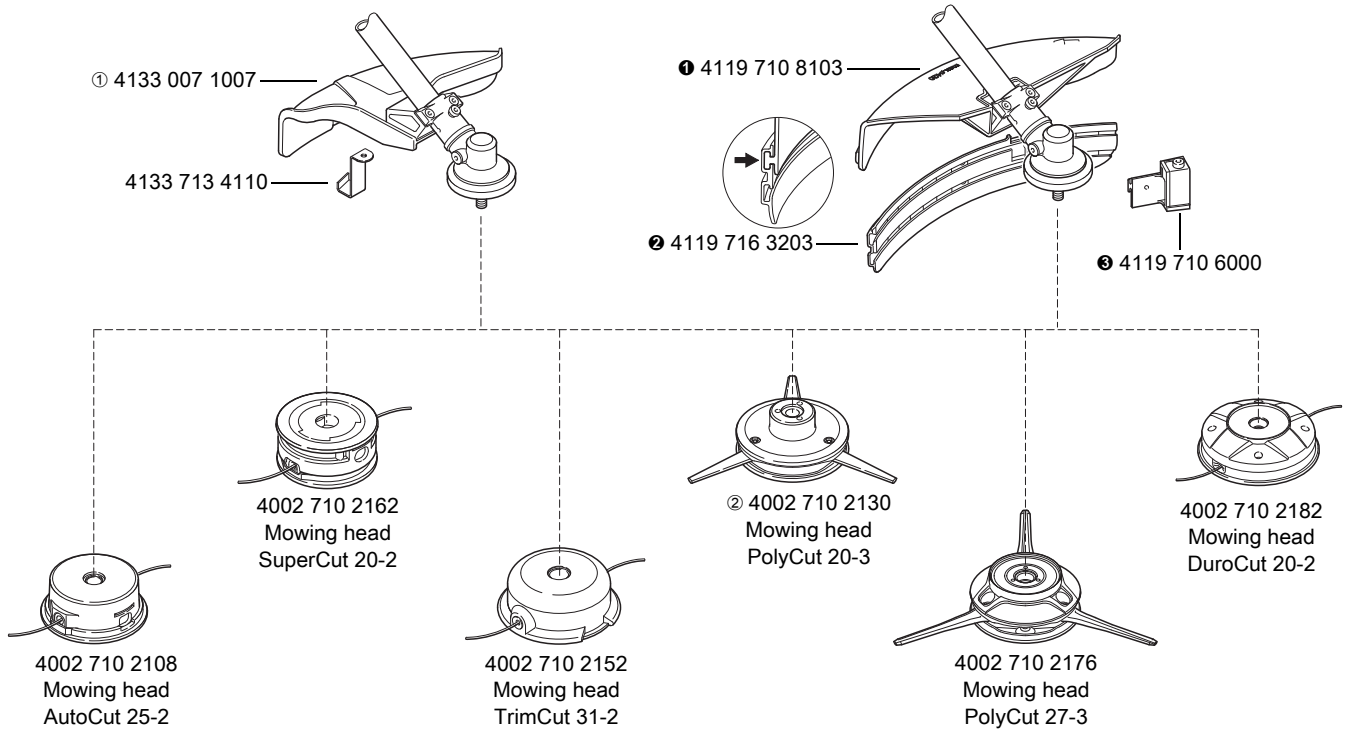

0000-GXX-5732-A0

① Approved in AUS, NZ only: 4133 007 1008

② No longer available

① + ② + ③ = 4119 007 1027

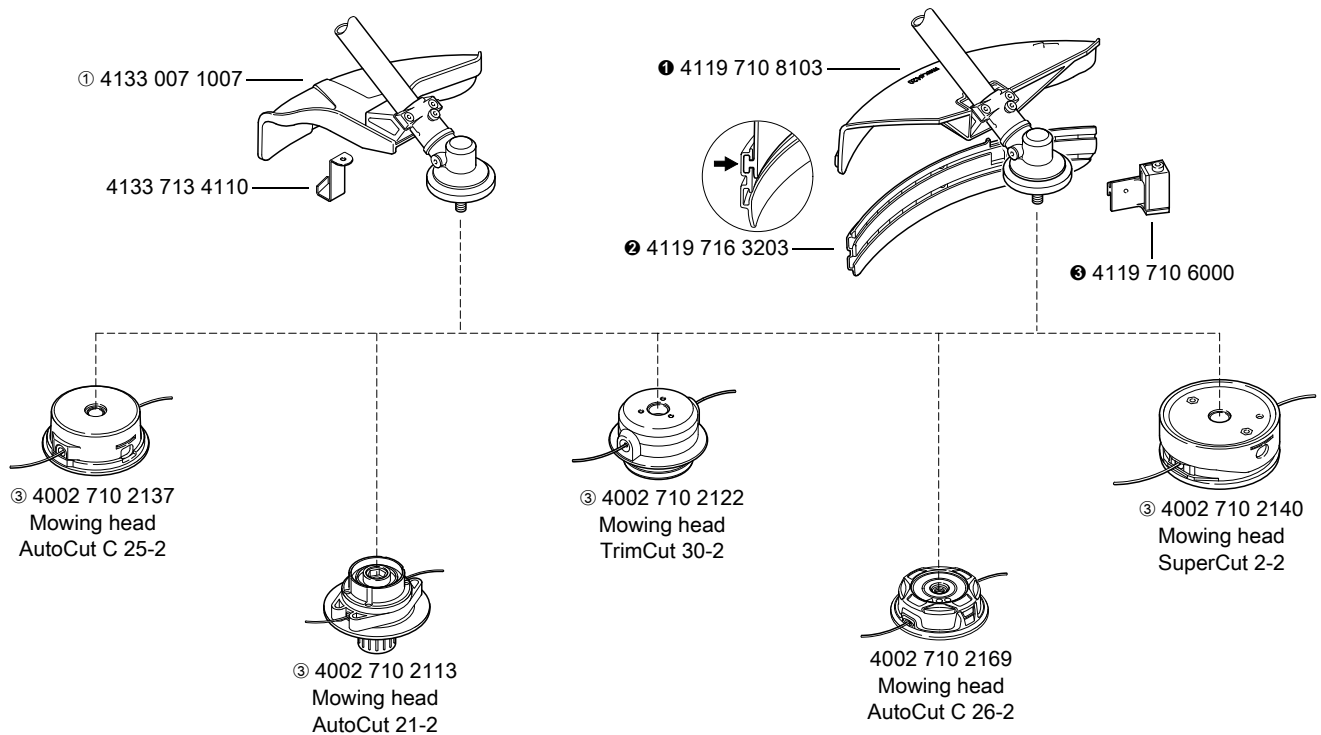

0000-GXX-3449-A0

① Approved in AUS, NZ only: 4133 007 1008

① + ② + ③ = 4119 007 1027

② Special accessory

③ No longer available

(a) from 1996 up to 2017 (b) from 2017 (c) from 2006 (d) FS 100 RX: Page 59

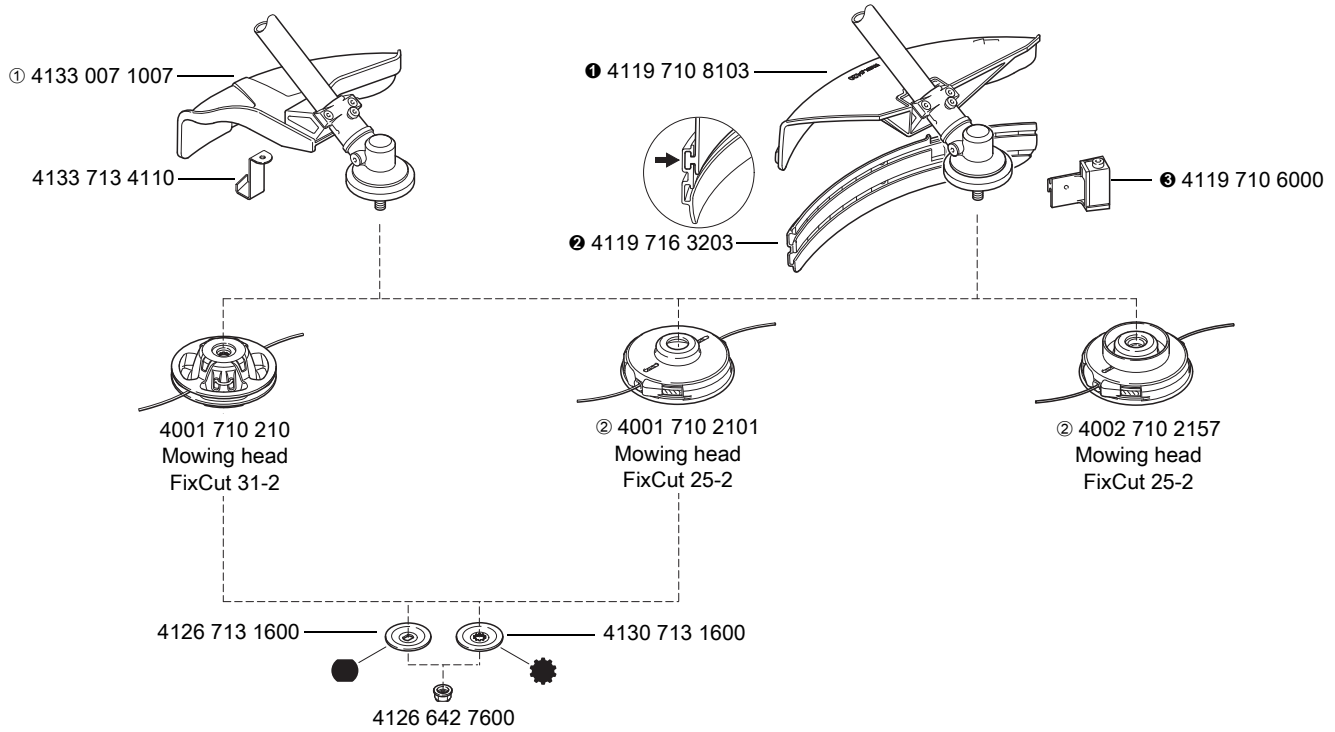

0000-GXX-5797-A0

① Approved in AUS, NZ only: 4133 007 1008

② No longer available

① + ② + ③ = 4119 007 1027

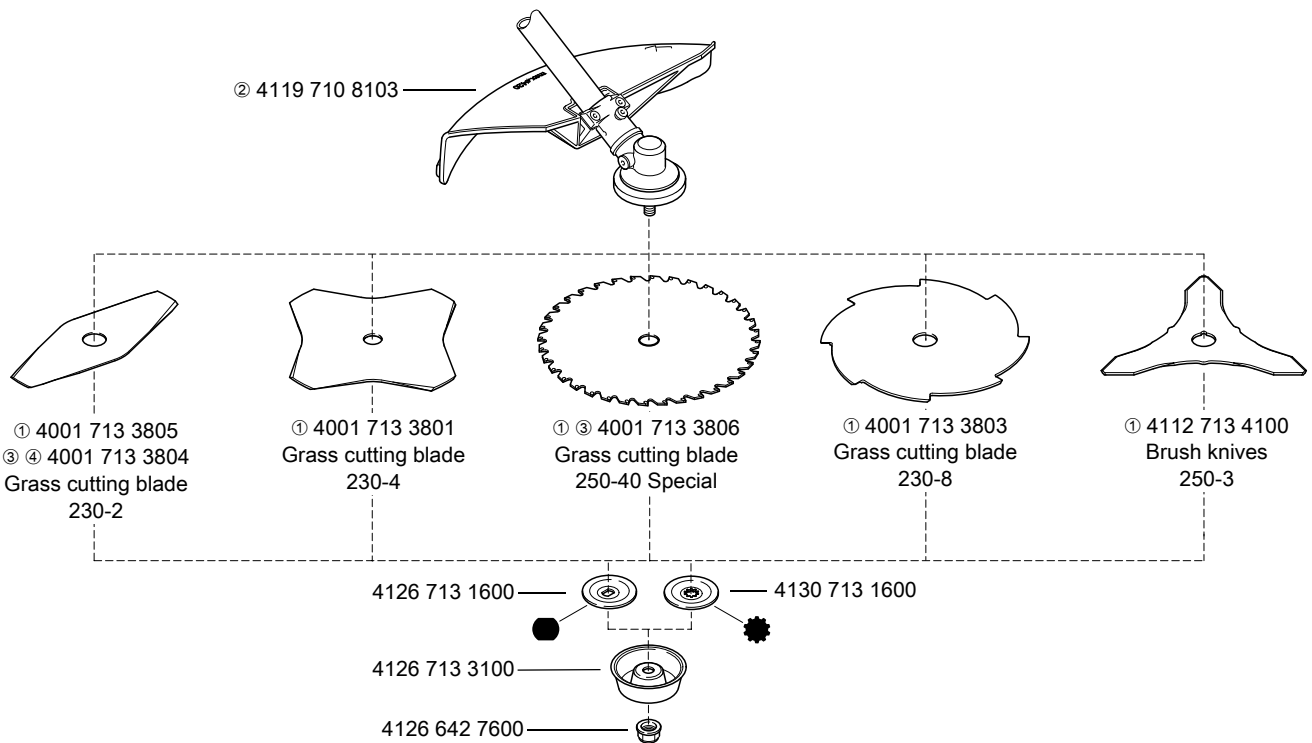

681KT851 KN

① Not approved for FS 85 RX, 100 RX, 110 RX

② Deflector for AUS, NZ see illustration marked "AUS, NZ"

③ Not approved for FS 65-4

④ No longer available

(a) from 1996 up to 2017 (b) from 2017 (c) from 2006 (d) FS 100 RX: Page 59

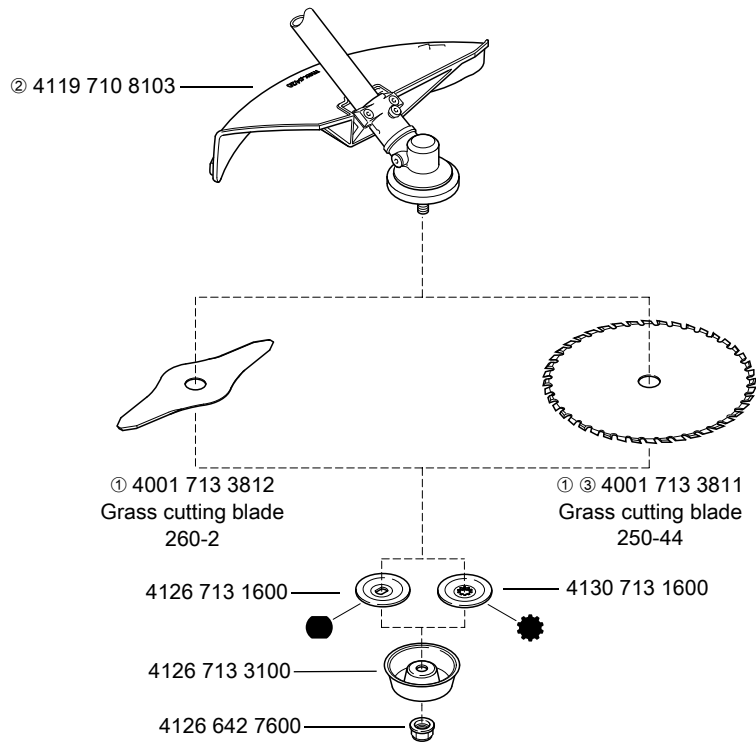

681KT1064 KN

- ① Not approved for FS 85 RX, 100 RX, 110 RX
- ② Deflector for AUS, NZ see illustration marked "AUS, NZ"
- ③ Not approved for FS 65-4

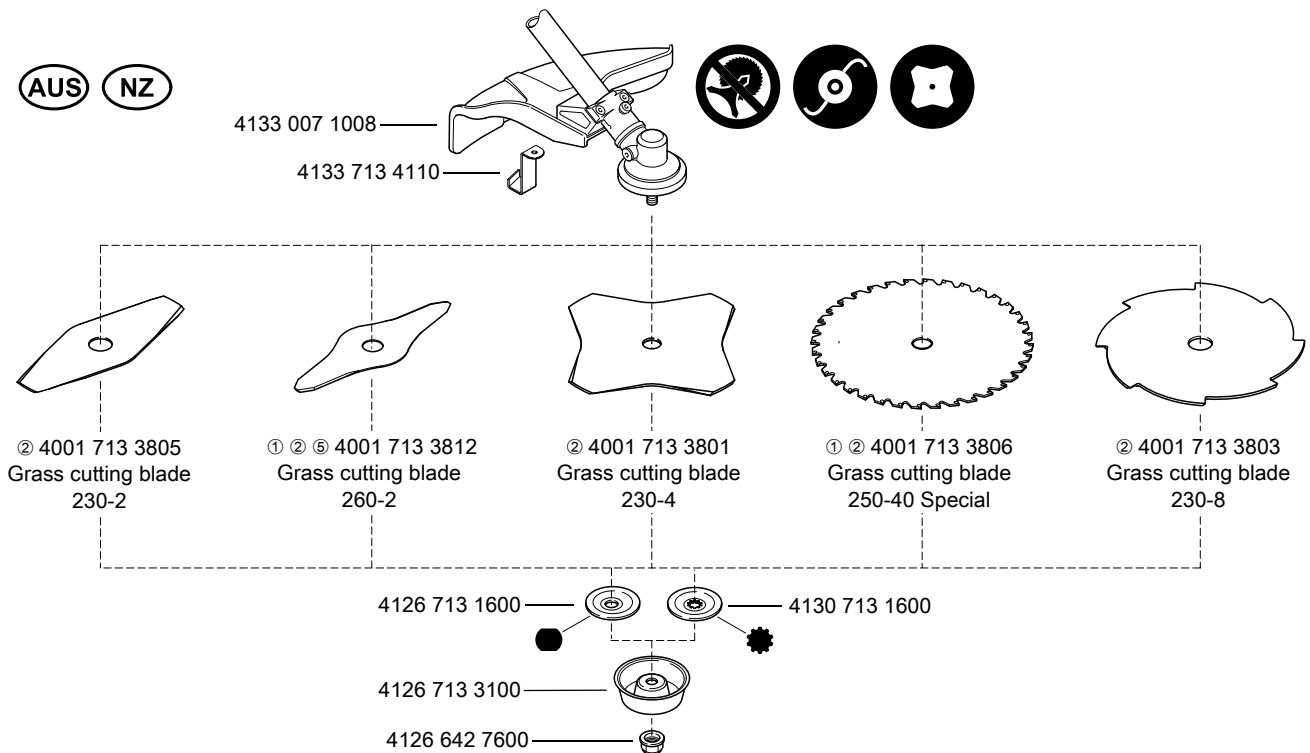

681KT1065 KN

- ① Not approved for FS 65-4
- ② Not approved for FS 85 RX, 100 RX, 110 RX

(a) from 1996 up to 2017 (b) from 2017 (c) from 2006 (d) FS 100 RX: Page 59

AUS NZ

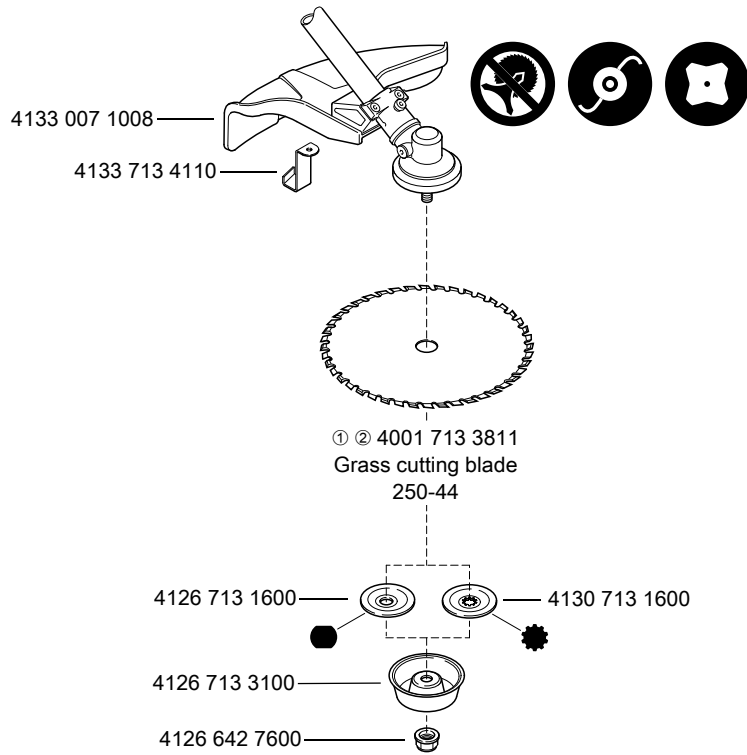

681KT1117 KN

① Not approved for FS 65-4

② Not approved for FS 85 RX, 100 RX, 110 RX

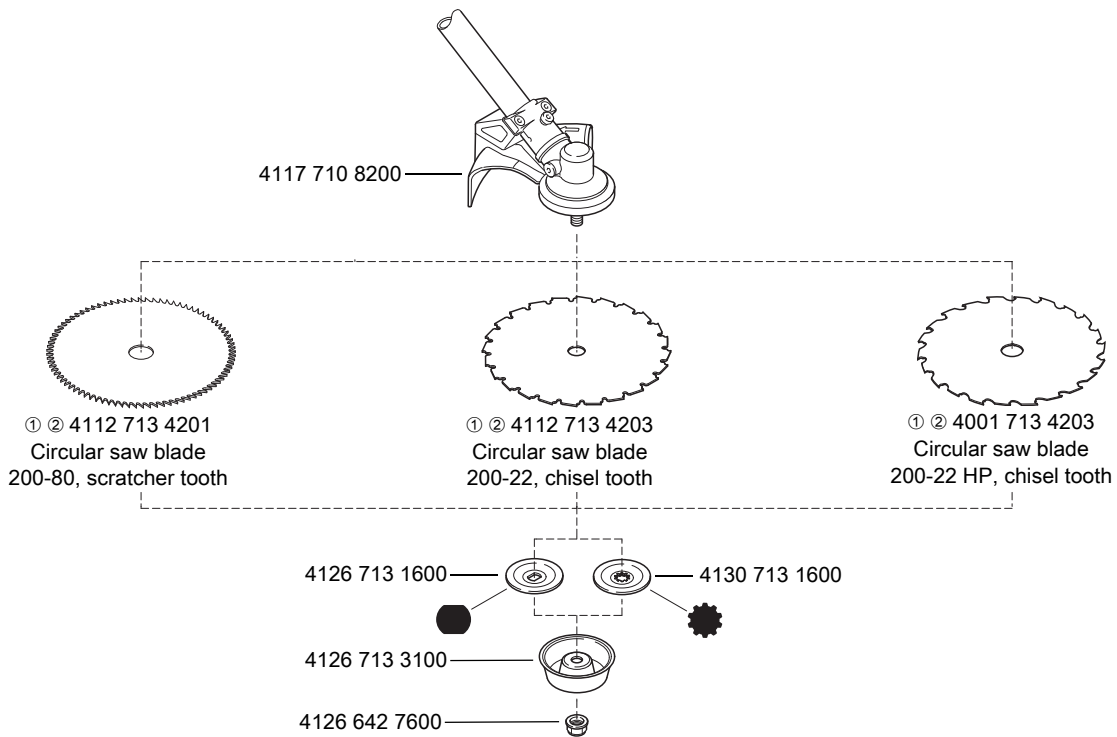

3000-GXX-5698-A0

① Not approved for FS 85 RX, 100 RX, 110 RX

② Not approved on brushcutters with loop handle

(a) from machine No. X 14 821 681

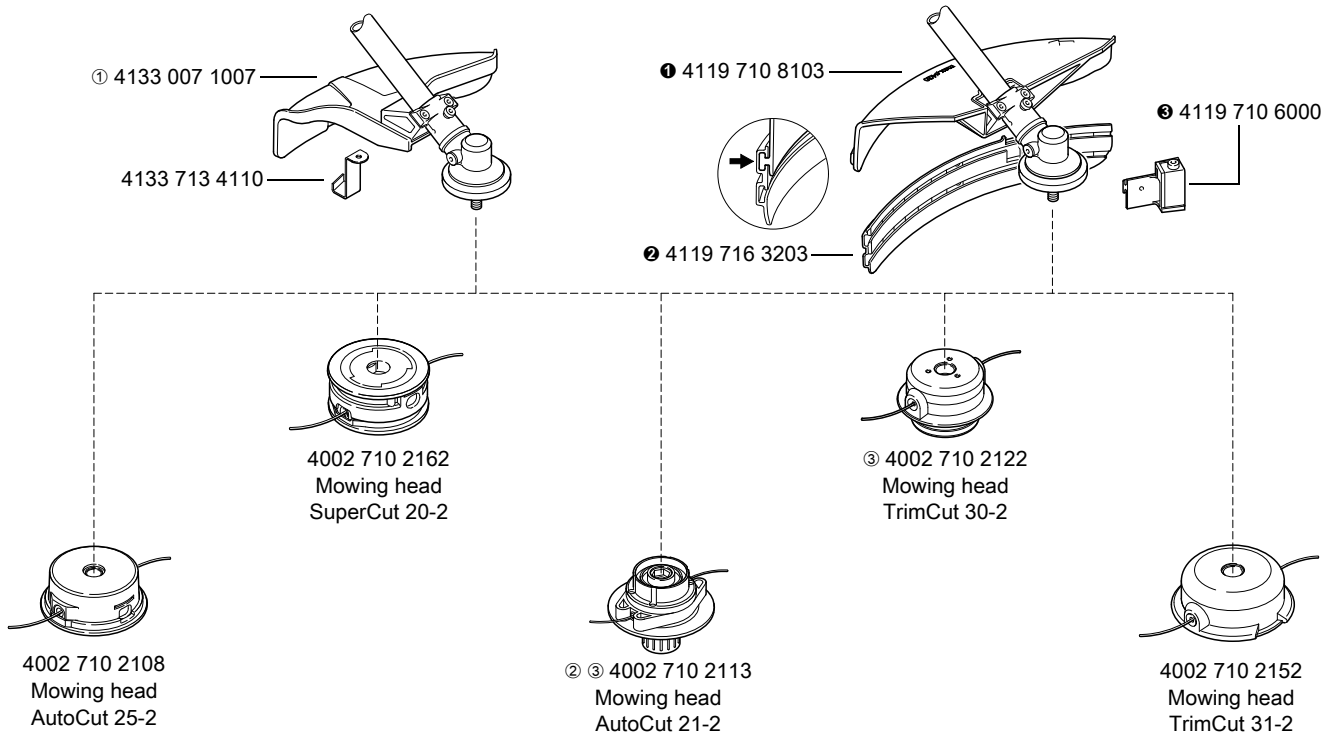

681KT802 KN

① Approved in AUS, NZ only: 4133 007 1008

① + ② + ③ = 4119 007 1027

② Not approved for FS 81, 86, 88, 106, 108

③ No longer available

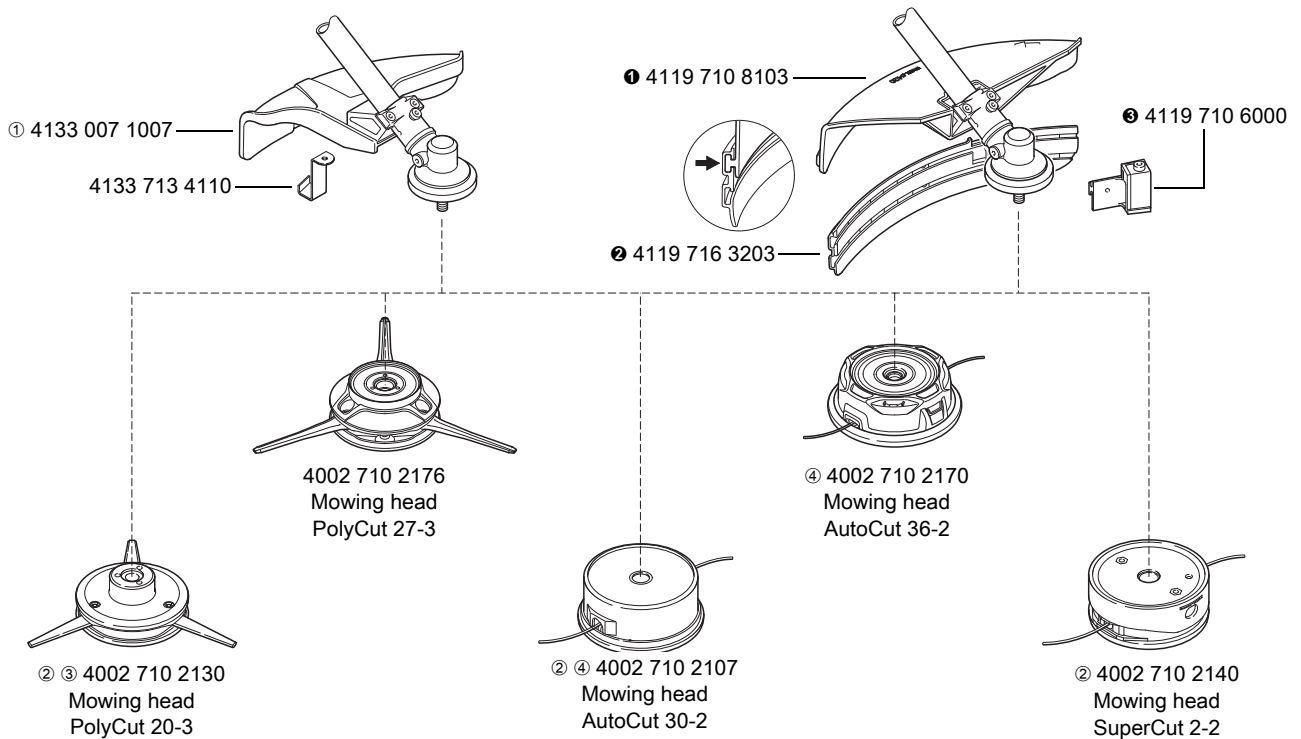

3000-GXX-5734-A0

① Approved in AUS, NZ only: 4133 007 1008

① + ② + ③ = 4119 007 1027

② No longer available

③ Not approved for FS 86, 88, 106, 108

④ Not approved for FS 66, 74, 76, 81

(a) from machine No. X 14 821 681

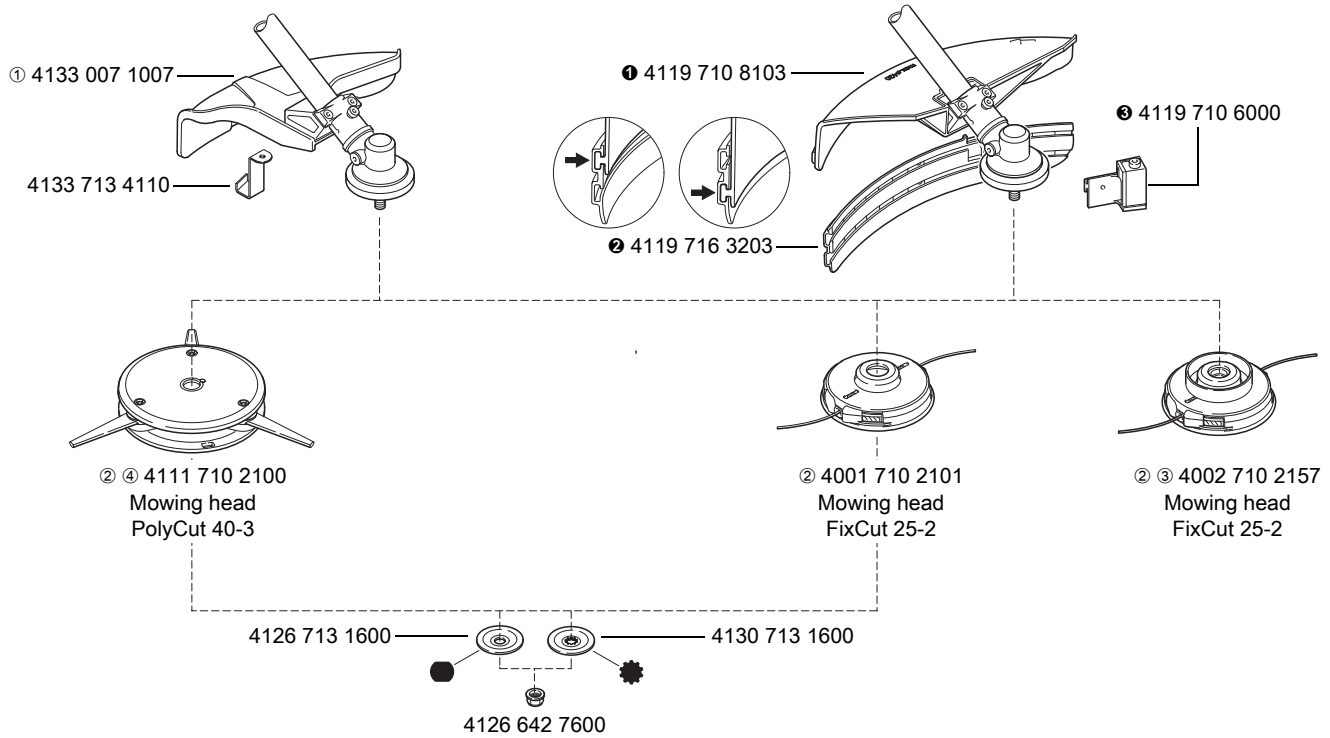

681KT519-A1

① Approved in AUS, NZ only: 4133 007 1008

② No longer available

③ Not approved for FS 66, 81, 86, 88, 106, 108

④ Not approved for FS 66, 74, 76, 81

① + ② + ③ = 4119 007 1027

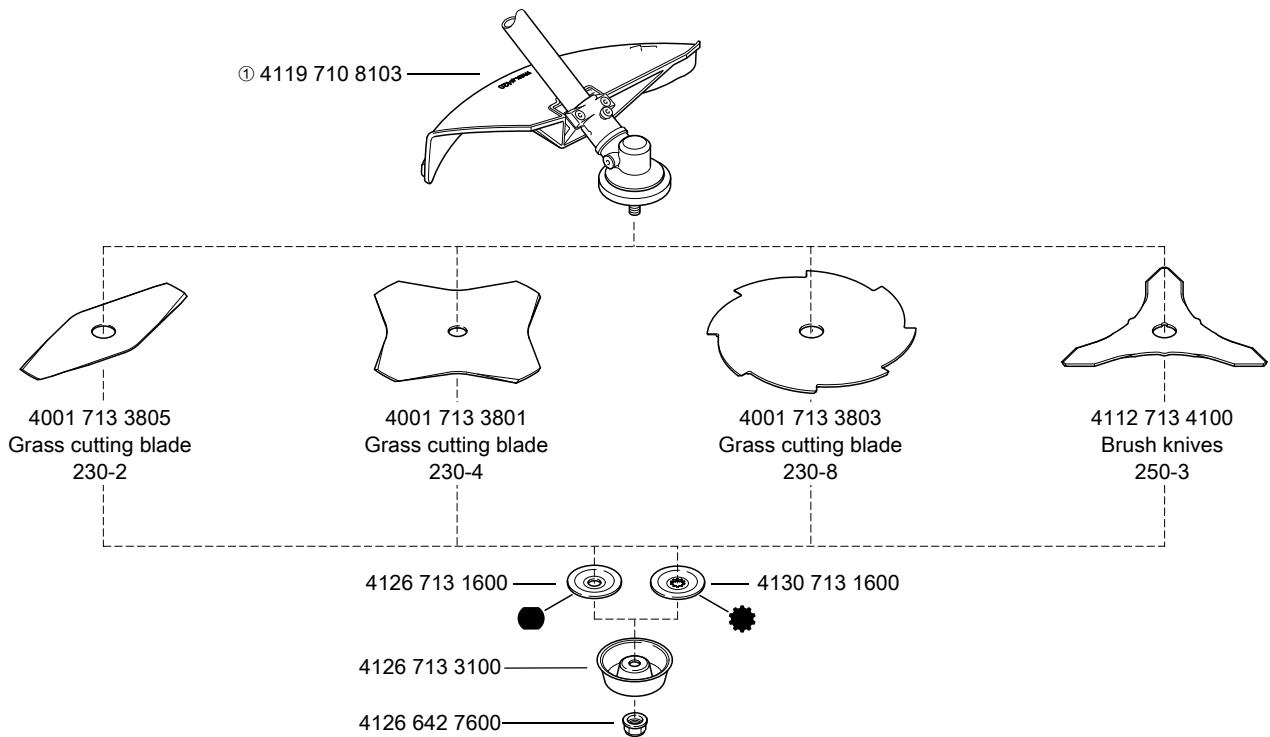

681KT520 KN

① Deflector for AUS, NZ see illustration marked "AUS, NZ"

(a) from machine No. X 14 821 681

AUS NZ

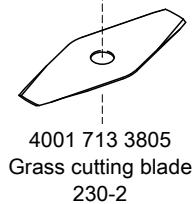
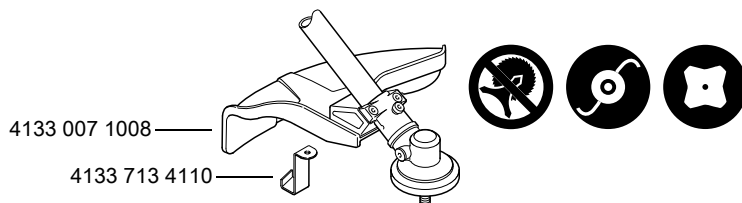

4001 713 3805
Grass cutting blade
230-2

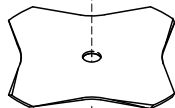

4001 713 3801
Grass cutting blade
230-4

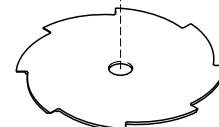

4001 713 3803
Grass cutting blade
230-8

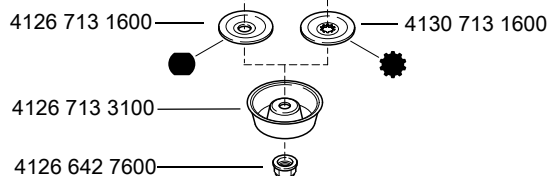

681KT864 KN

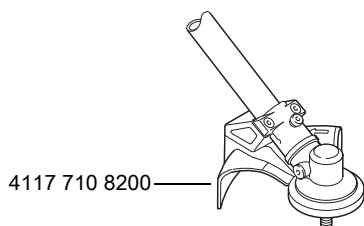

4117 710 8200

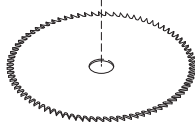

4112 713 4201
Circular saw blade
200-80, scratcher tooth

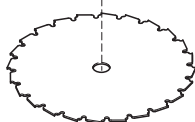

4112 713 4203
Circular saw blade
200-22, chisel tooth

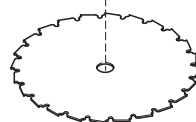

4001 713 4203
Circular saw blade
200-22 HP, chisel tooth

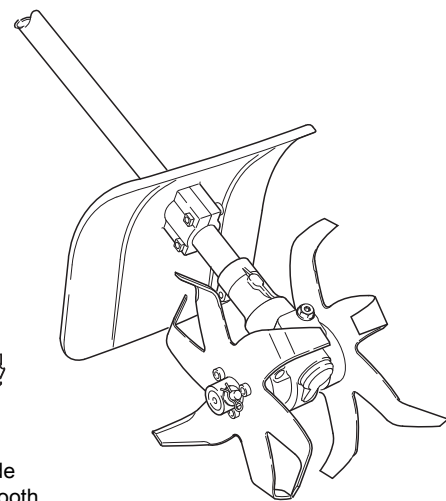
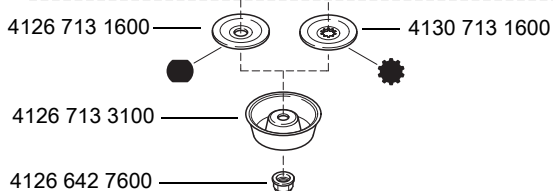

① ③ 4600 710 1502
Cultivator BC 35
② ③ 4600 710 1500
Cultivator BC 30

381KT521-A1

① Not approved for FS 66

② Not approved for FS 76, 81, 86, 88, 106, 108

③ No longer available

④ Not approved on brushcutters with loop handle

(a) up to machine No. X 14 821 680

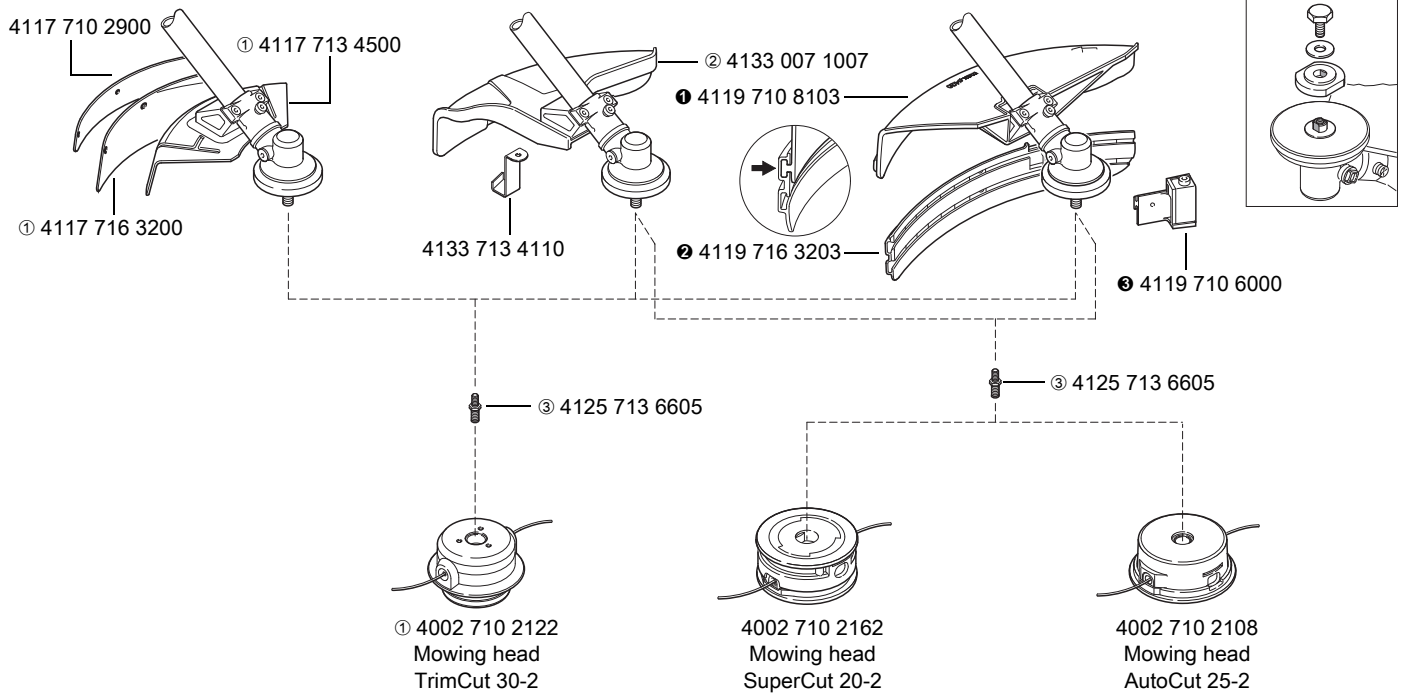

681KT951-A1

① No longer available

② Approved in AUS, NZ only: 4133 007 1008

③ Special accessory

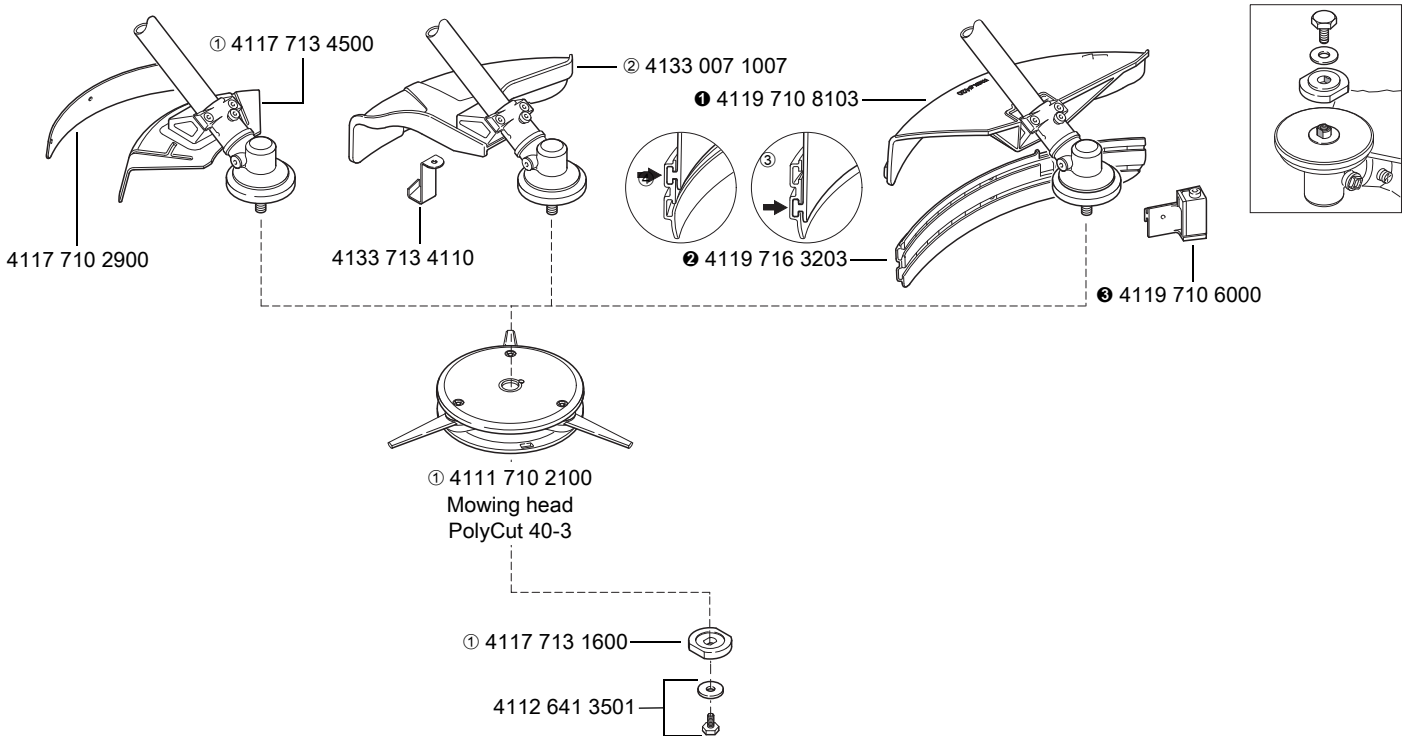

381KT523-A1

① No longer available

② Approved in AUS, NZ only: 4133 007 1008

① + ② + ③ = 4119 007 1027

(a) up to machine No. X 14 821 680

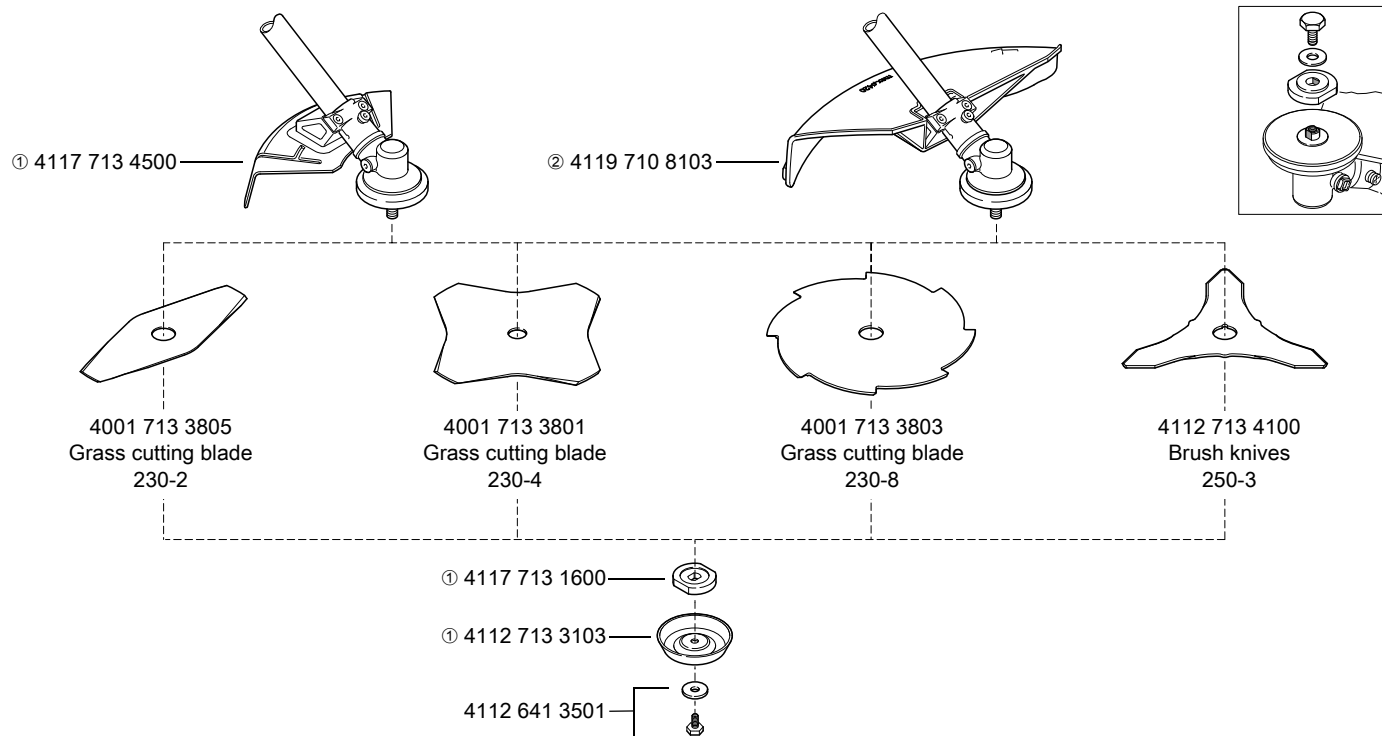

681KT524 KN

① No longer available

② Deflector for AUS, NZ see illustration marked "AUS, NZ"

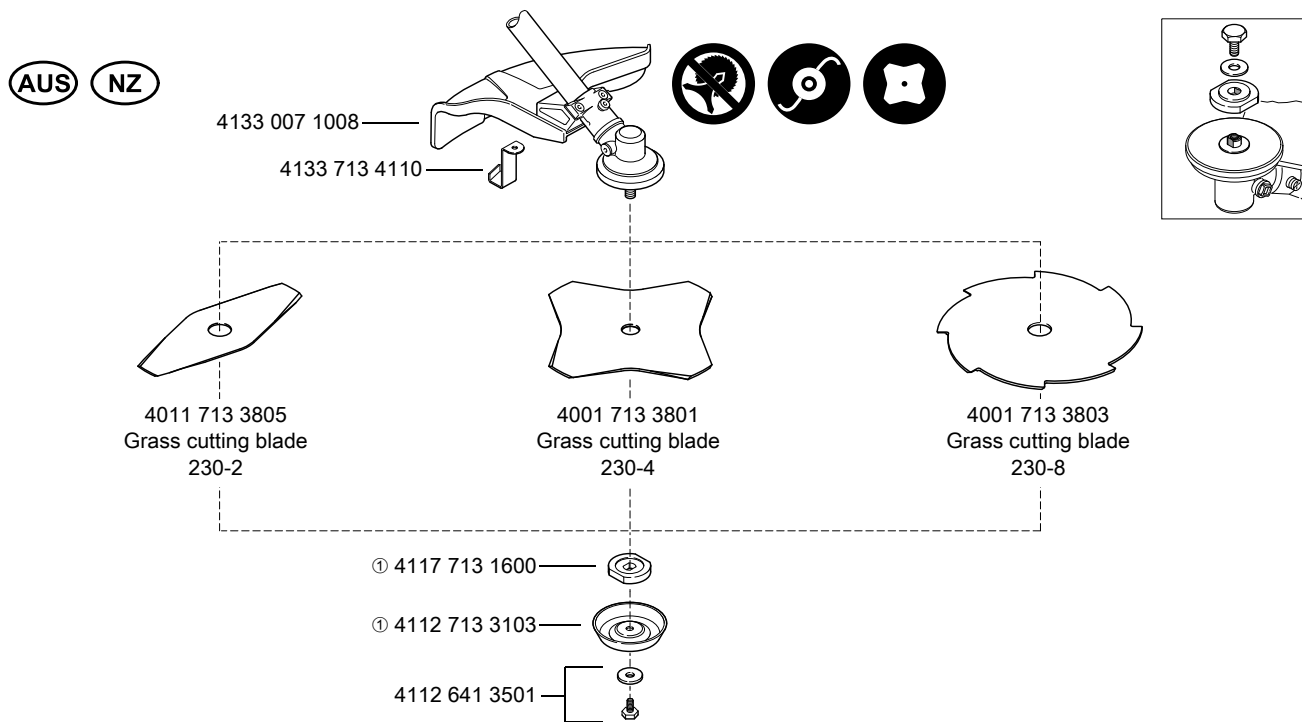

681KT535 KN

① No longer available

(a) up to machine No. X 14 821 680

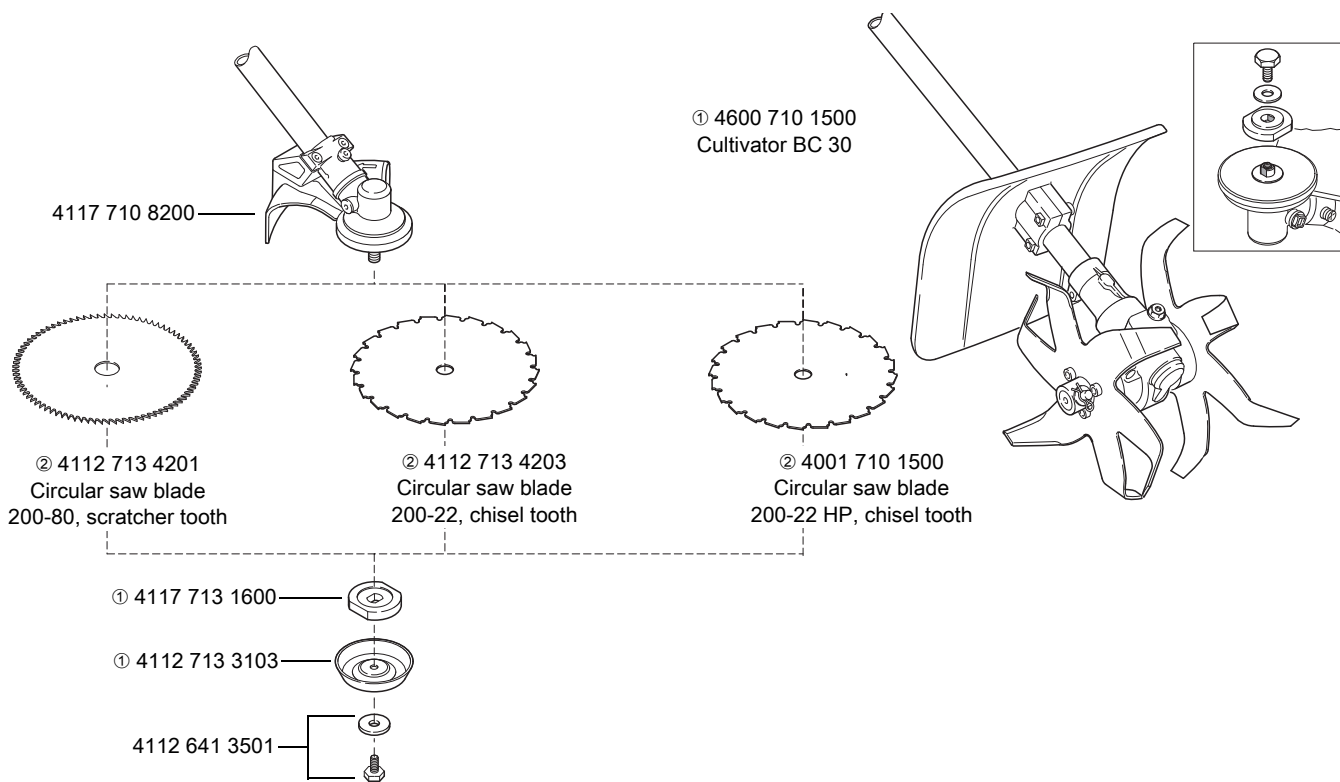

681KT525-A1

① No longer available

② Not approved on brushcutters with loop handle

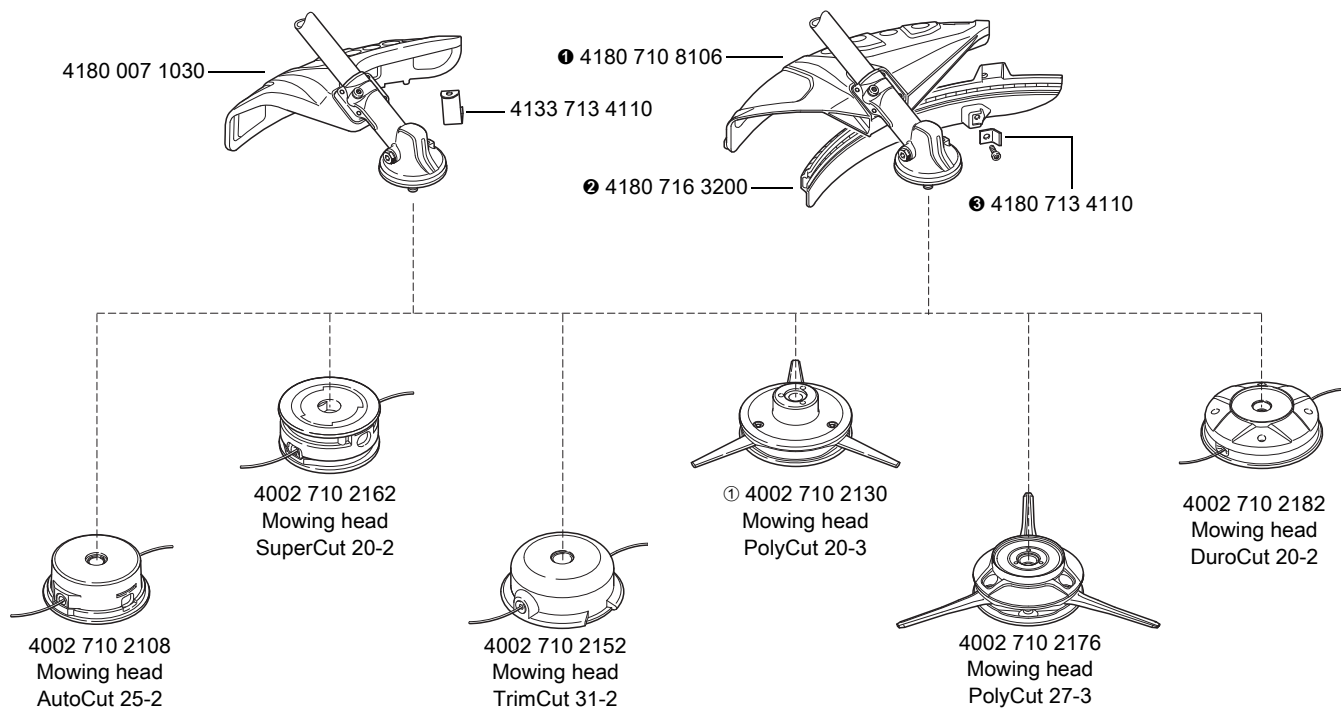

0000-GXX-5735-A0

① No longer available

① + ② + ③ = 4180 007 1028

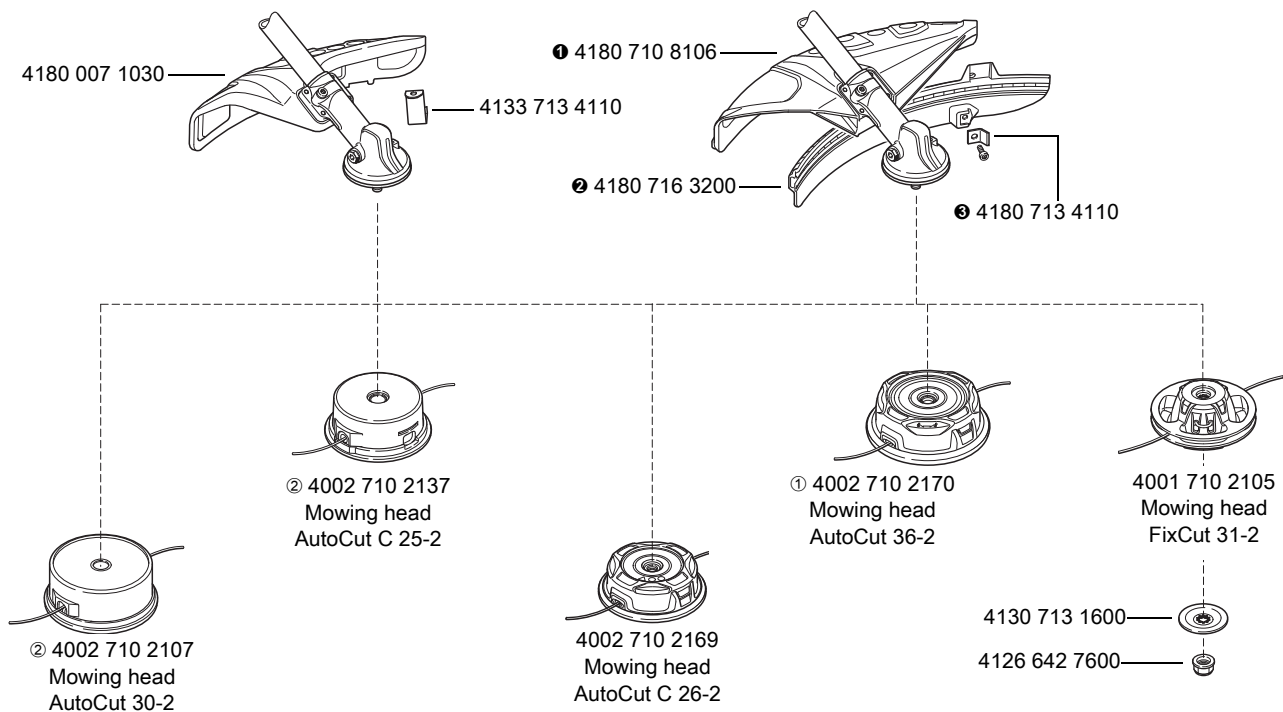

0000-GXX-5701-A0

① Not approved for FS 89

② No longer available

① + ② + ③ = 4180 007 1028

(a) FS 111 RX: Page 60

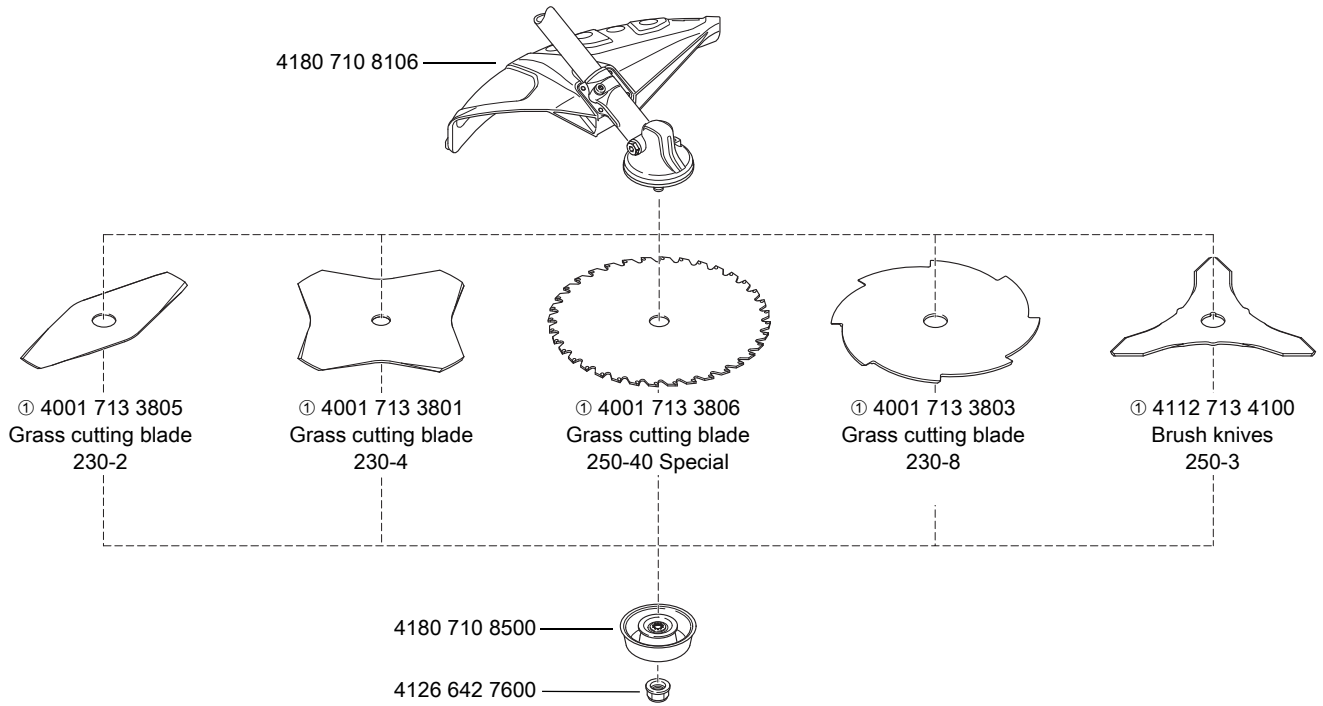

0000-GXX-3624-A0

① Not approved for FS 111 RX

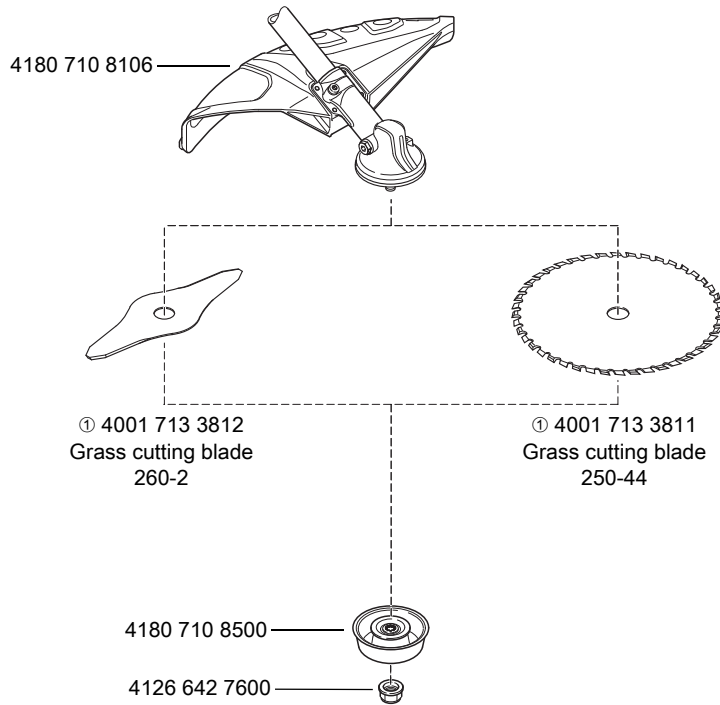

0000-GXX-3625-A0

① Not approved for FS 111 RX

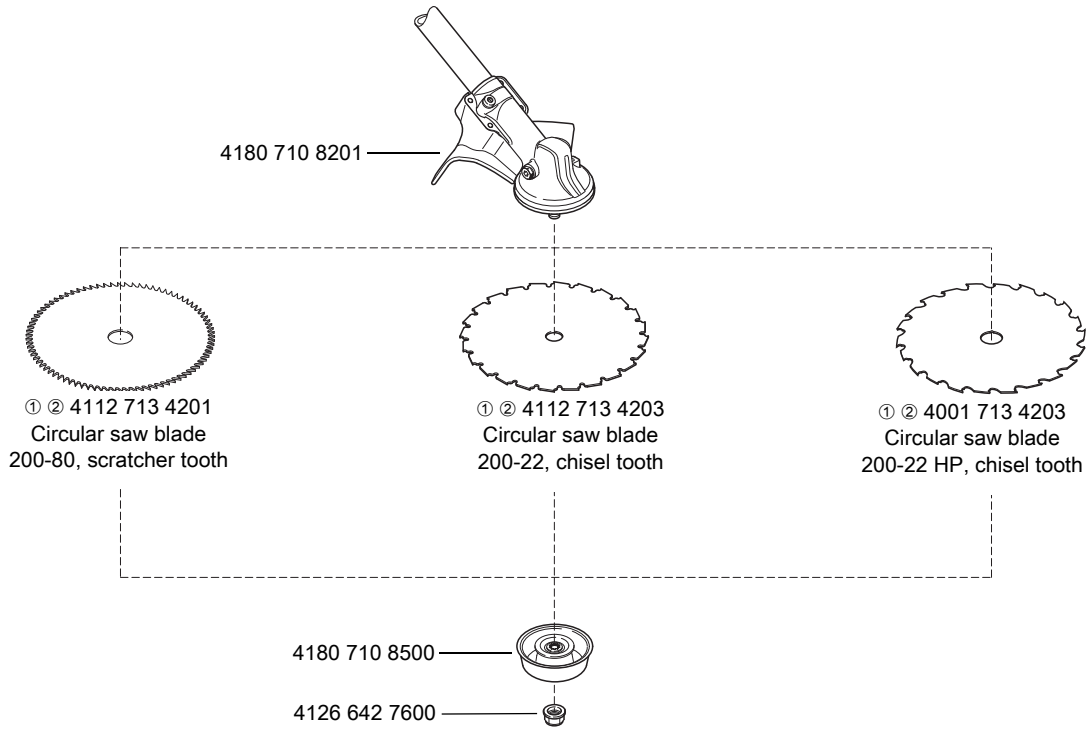

0000-GXX-5723-A0

① Not approved for FS 111 RX

② Not approved on brushcutters with loop handle

(a) from 2018

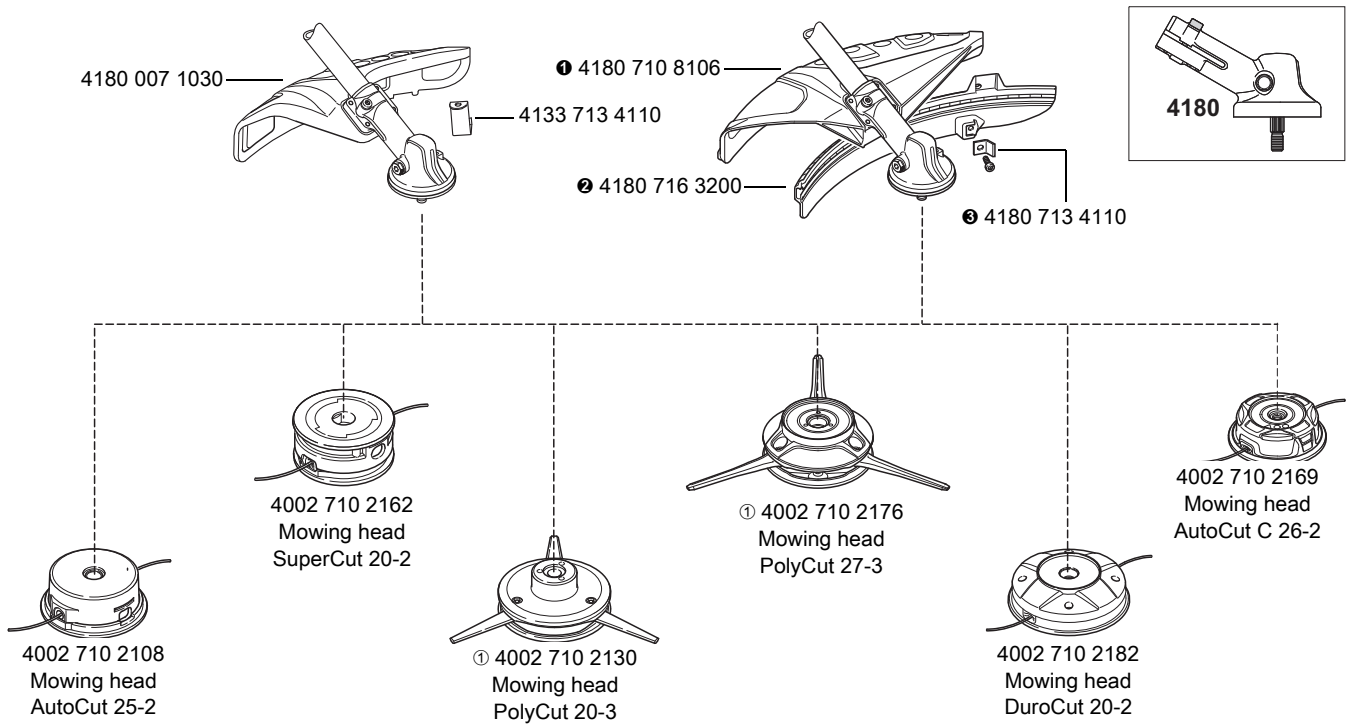

0000-GXX-5736-A0

① No longer available

① + ② + ③ = 4180 007 1028

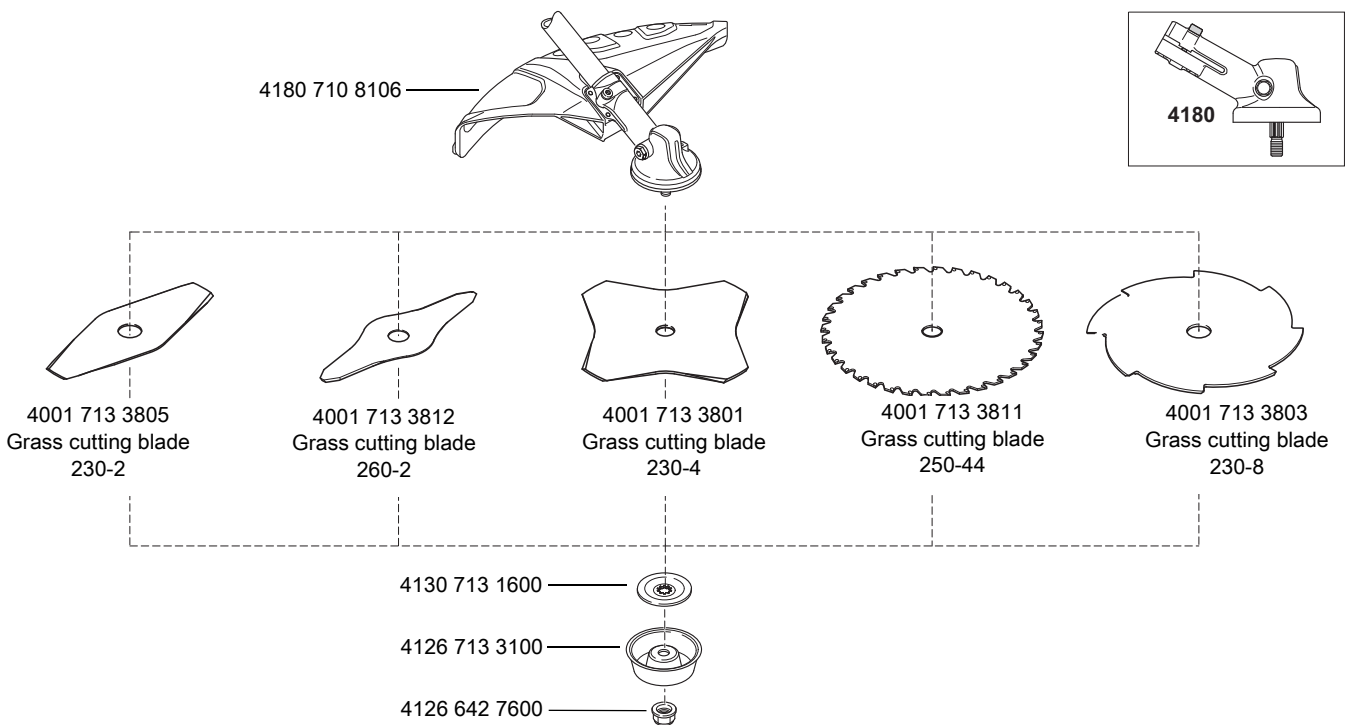

0000-GXX-6044-A0

(a) up to 2017

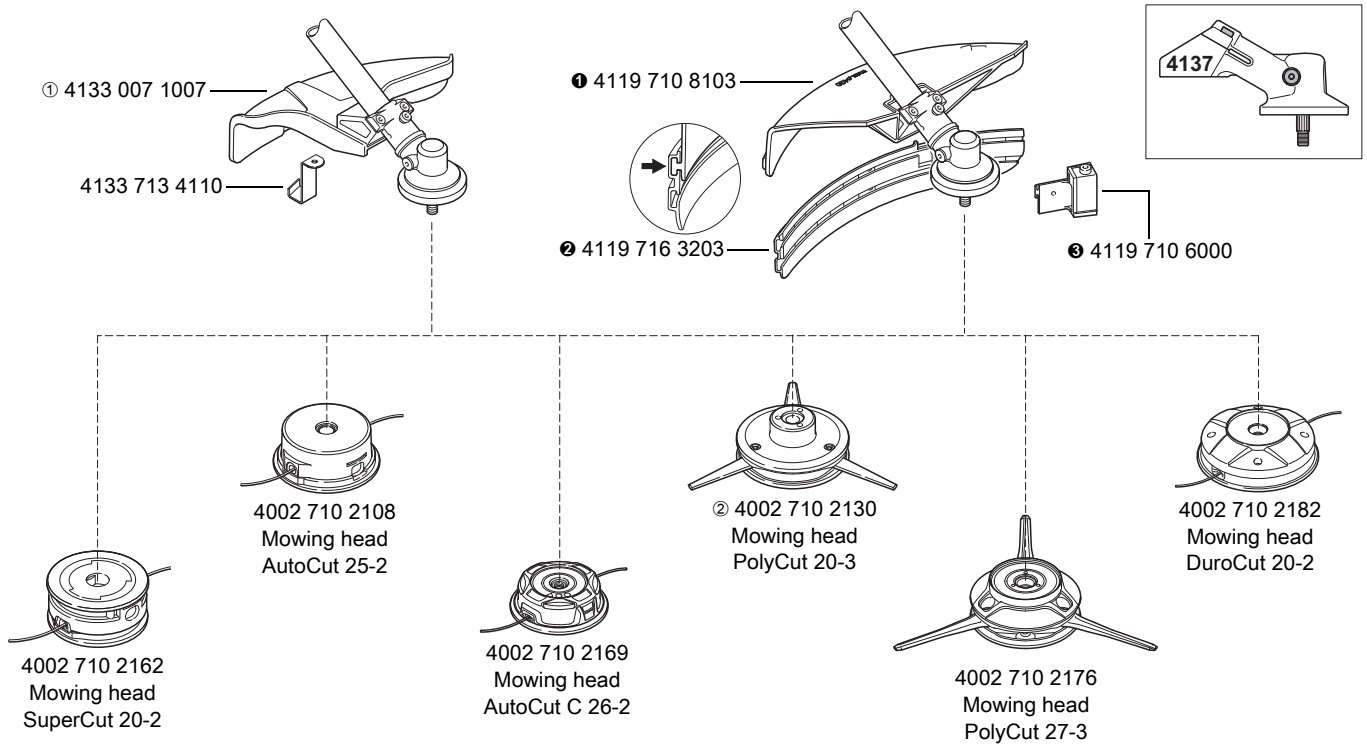

0000-GXX-5702-A0

① Approved in AUS, NZ only: 4133 007 1008

② No longer available

① + ② + ③ = 4119 007 1027

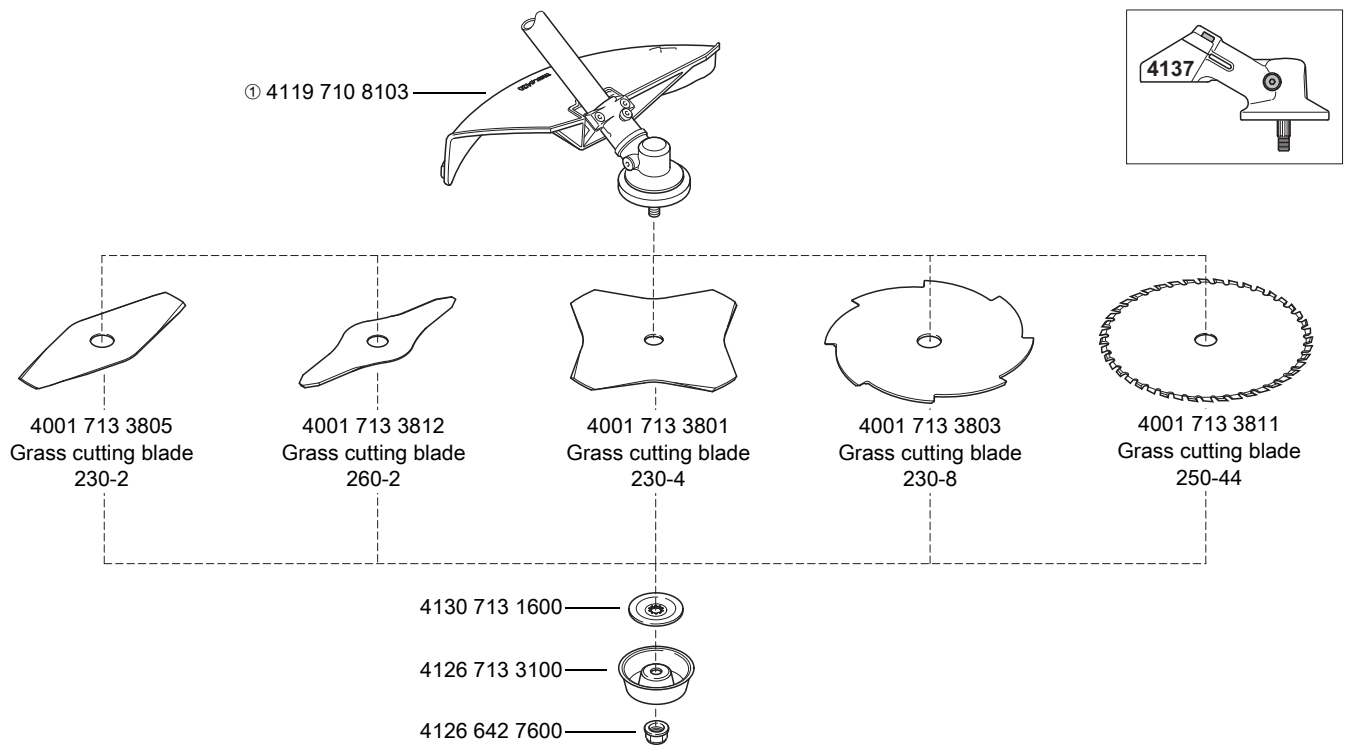

0000-GXX-5703-A0

① Deflector for AUS, NZ see illustration marked "AUS, NZ"

(a) up to 2017

AUS NZ

4133 007 1008

4133 713 4110

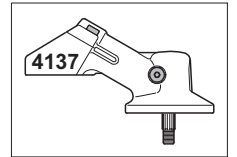
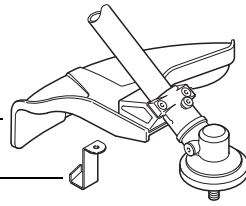

4001 713 3805
Grass cutting blade
230-2

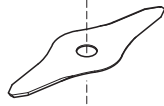

4001 713 3812
Grass cutting blade
260-2

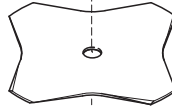

4001 713 3801
Grass cutting blade
230-4

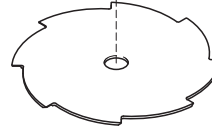

4001 713 3803
Grass cutting blade
230-8

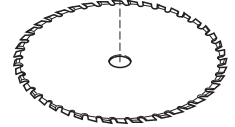

4001 713 3811
Grass cutting blade
250-44

4130 713 1600



4126 713 3100



4126 642 7600



0000-GXX-5704-A0

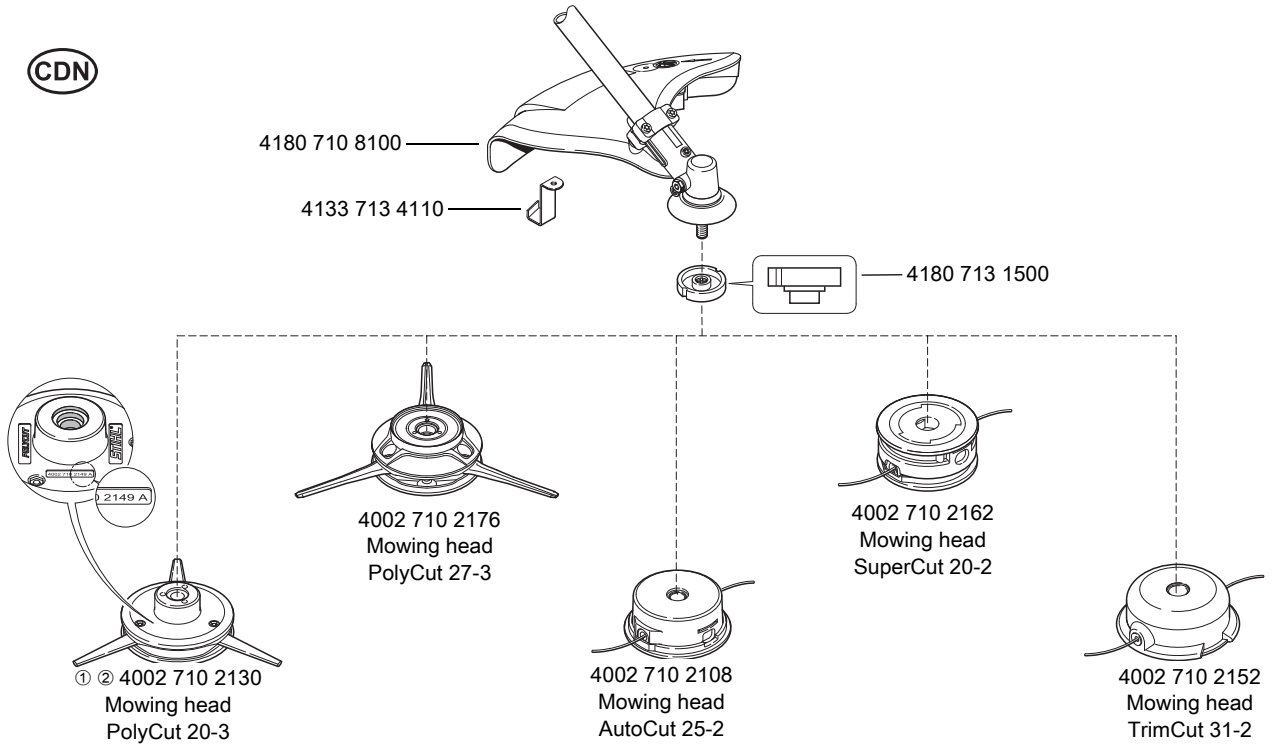

0000-GXX-5737-A0

- ① Only version with part No. "2149 A" is approved
- ② No longer available

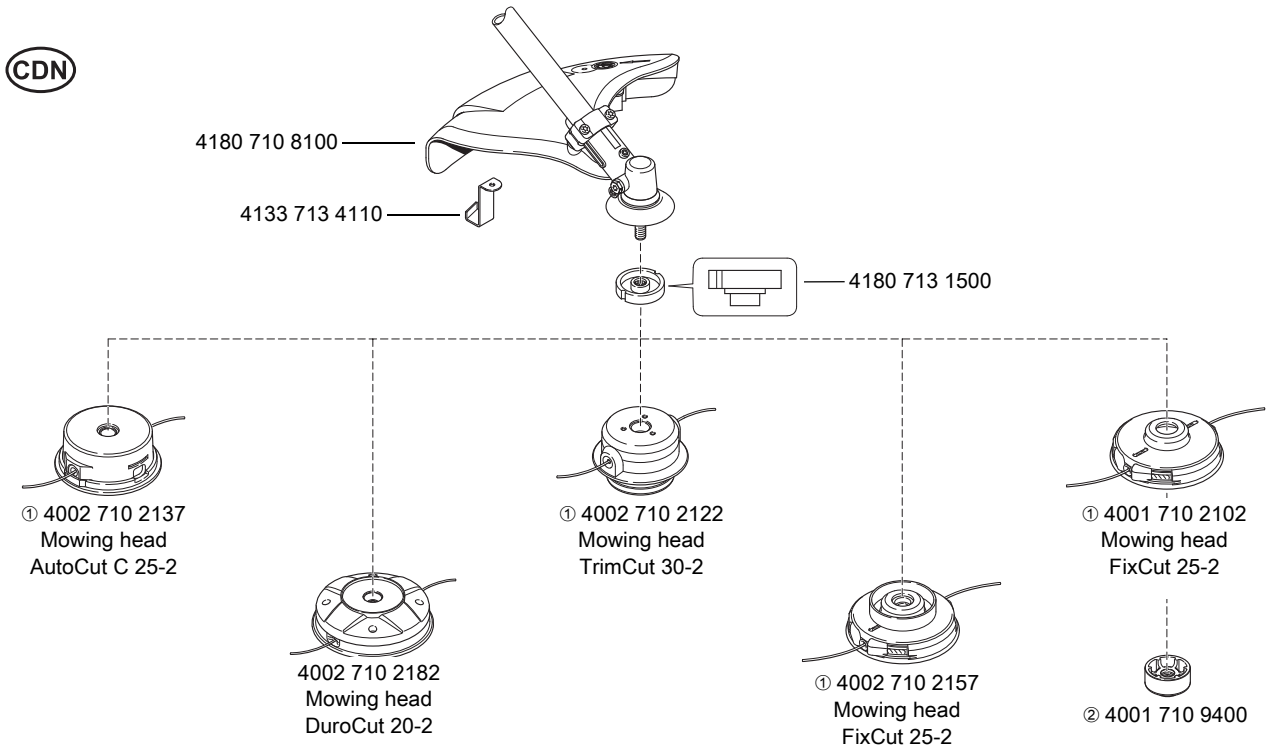

0000-GXX-3455-A0

- ① No longer available
- ② Special accessories

CDN

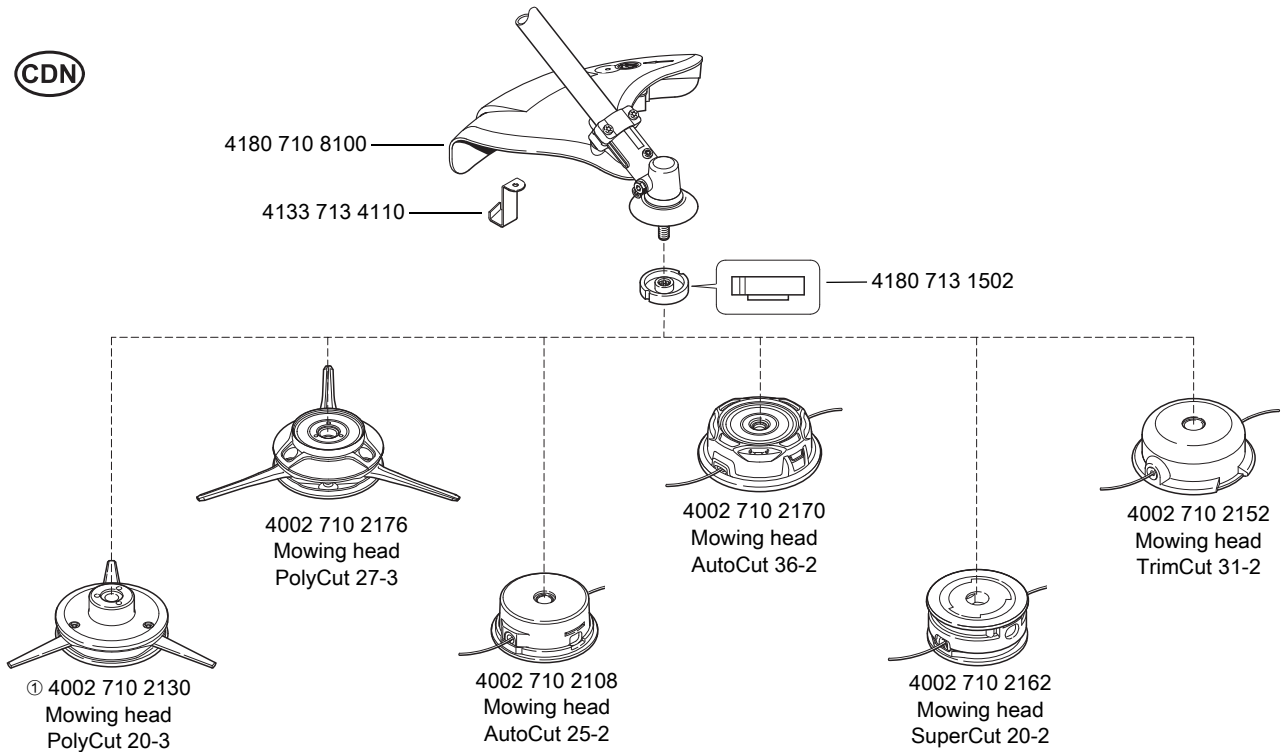

0000-GXX-5738-A0

① No longer available

CDN

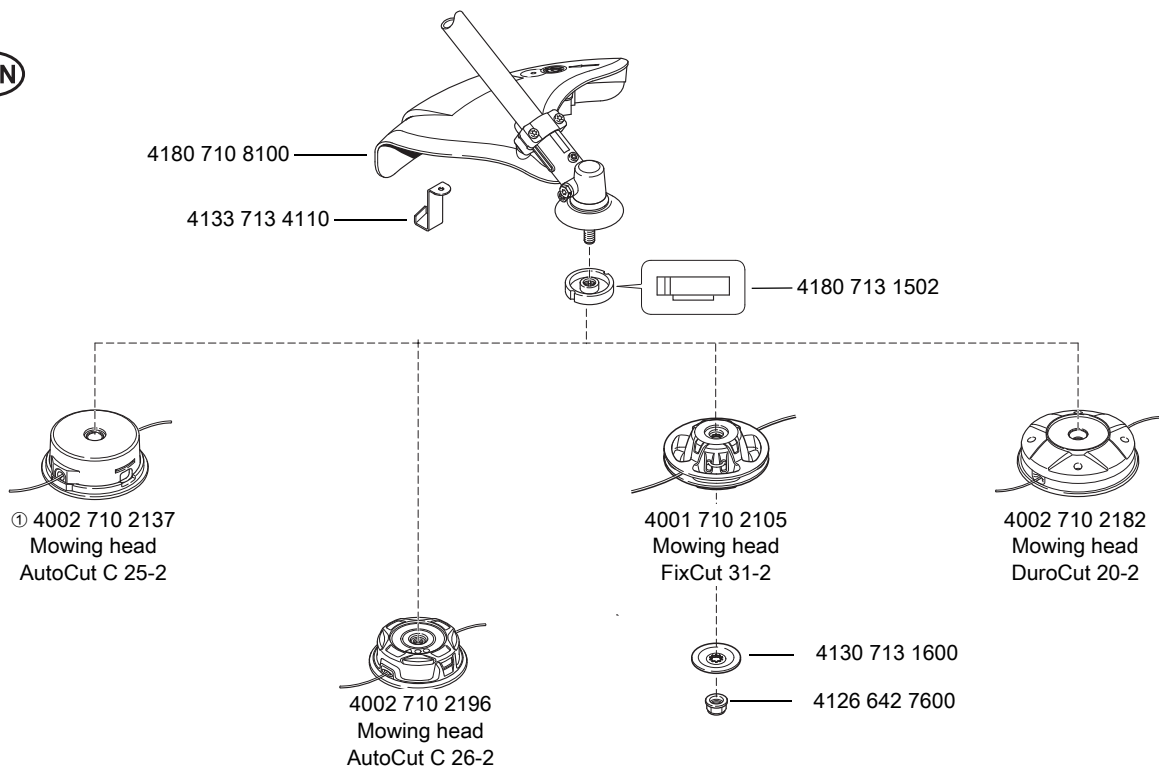

0000-GXX-3457-A1

① No longer available

(a) from 2016

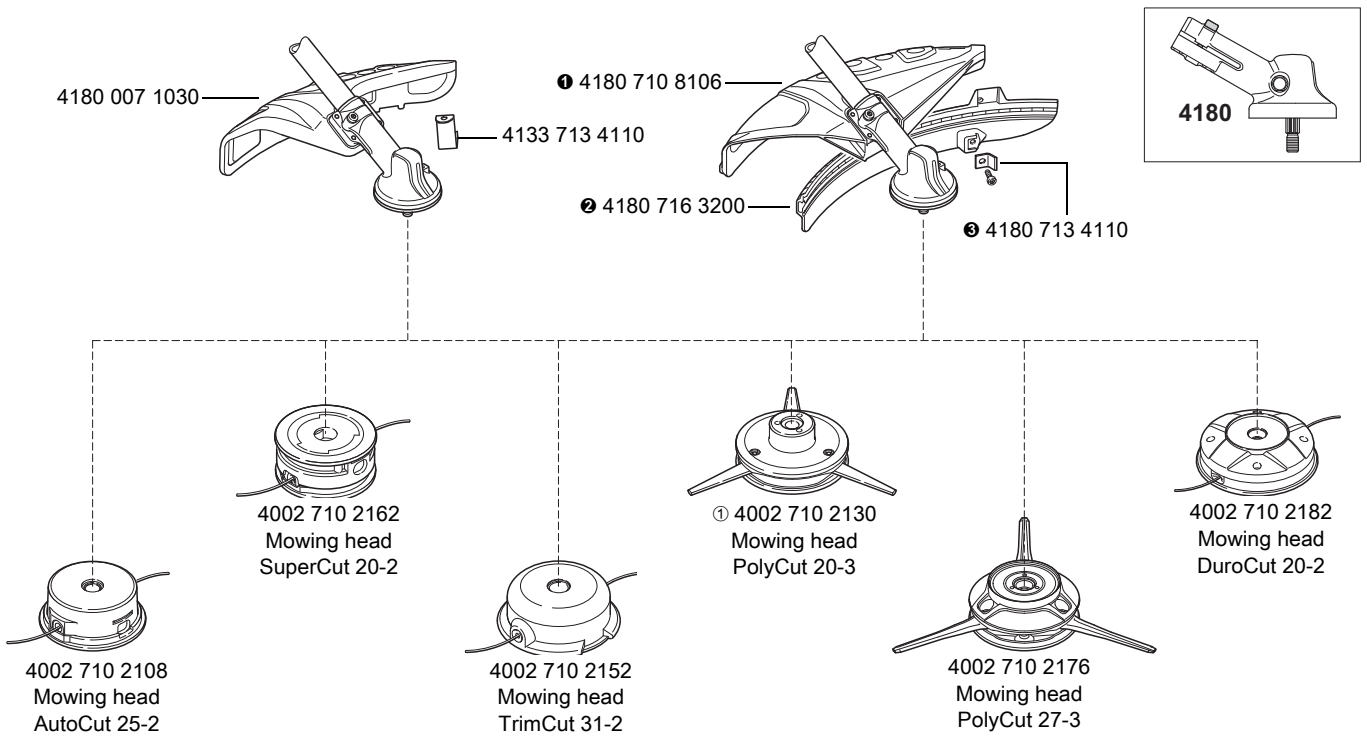

0000-GXX-5739-A0

① No longer available

① + ② + ③ = 4180 007 1028

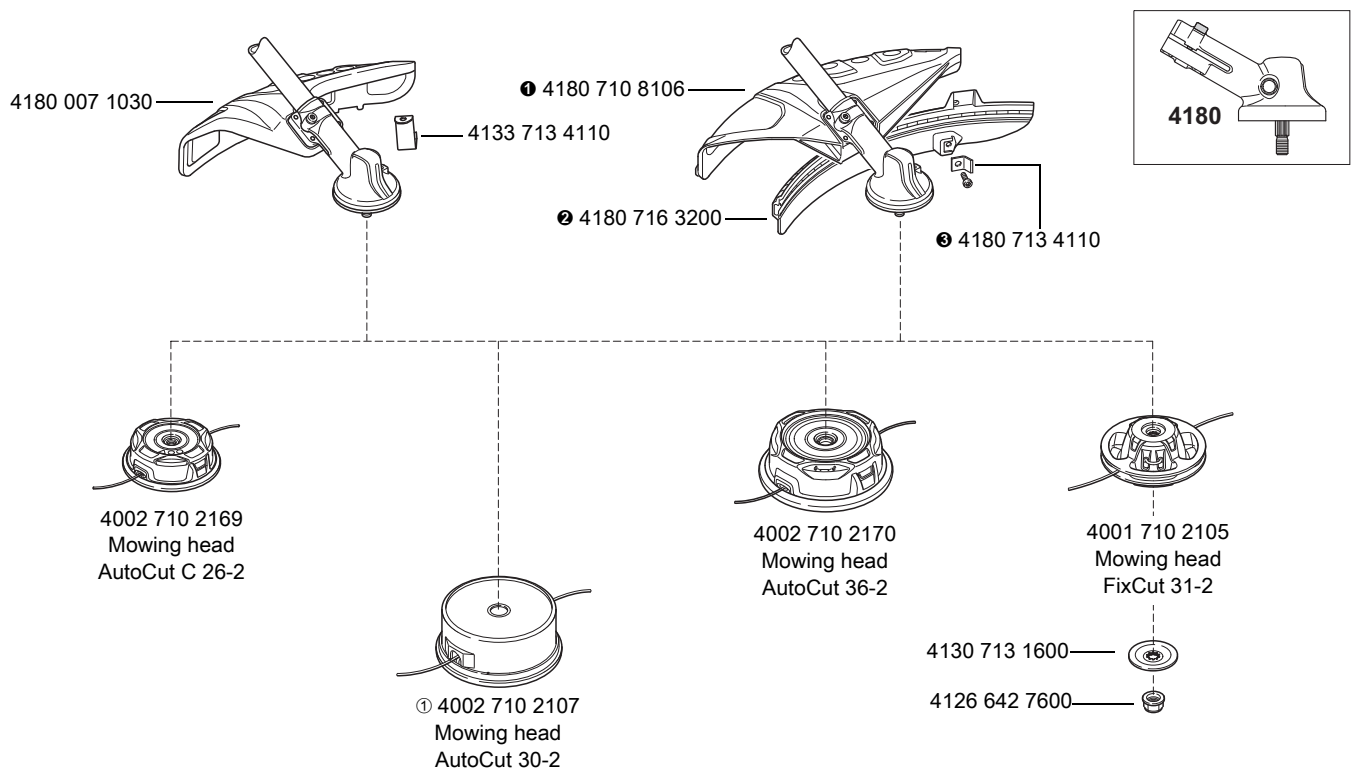

0000-GXX-5705-A0

① No longer available

① + ② + ③ = 4180 007 1028

(a) from 2016

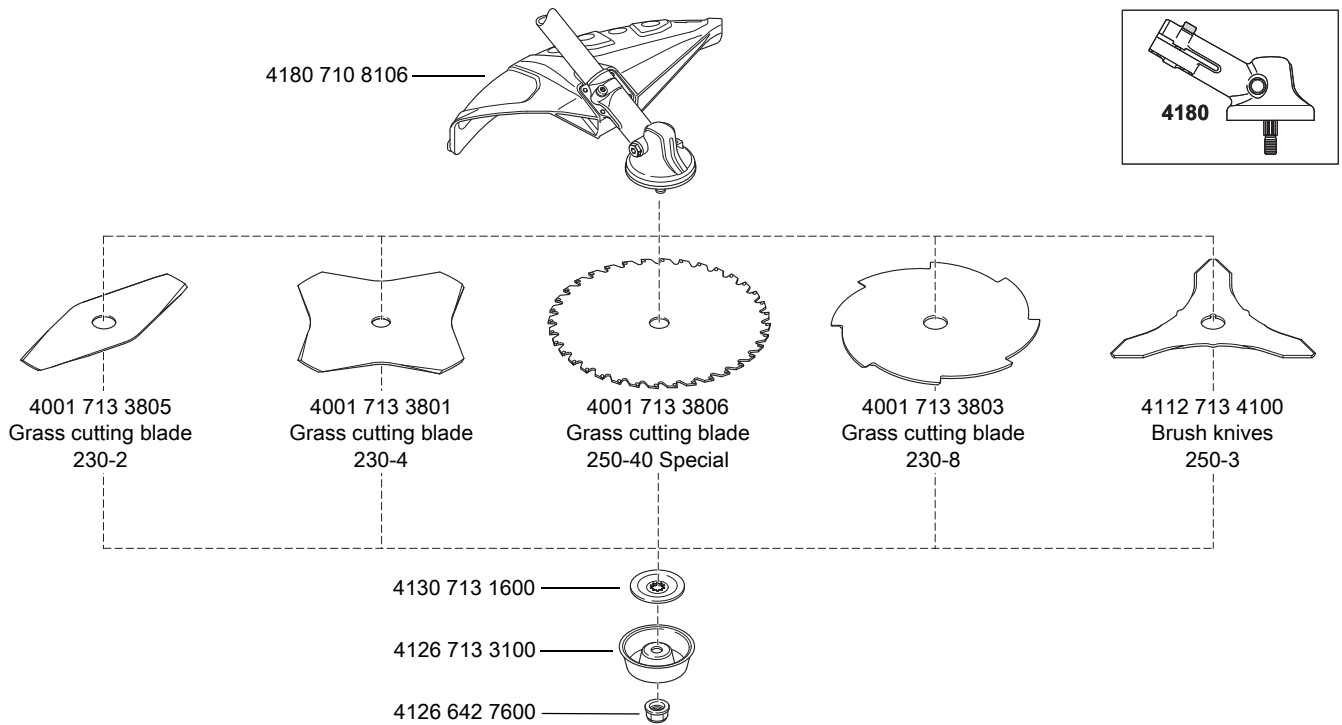

0000-GXX-3464-A0

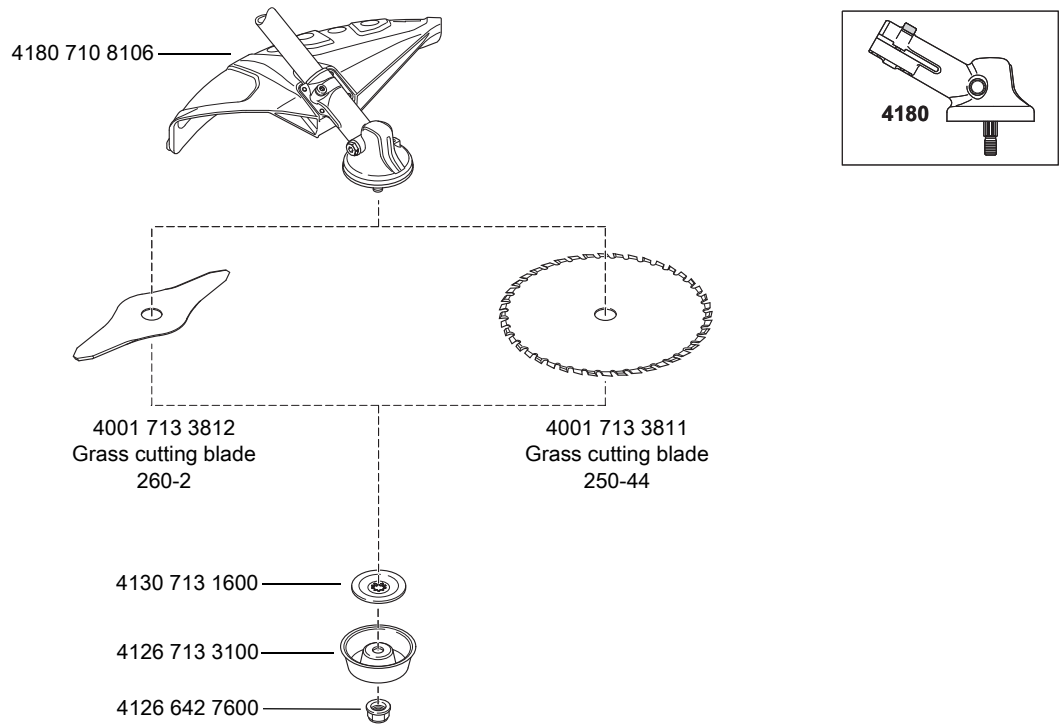

0000-GXX-3465-A0

(a) from 2016

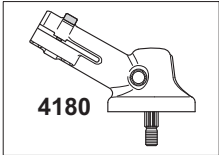
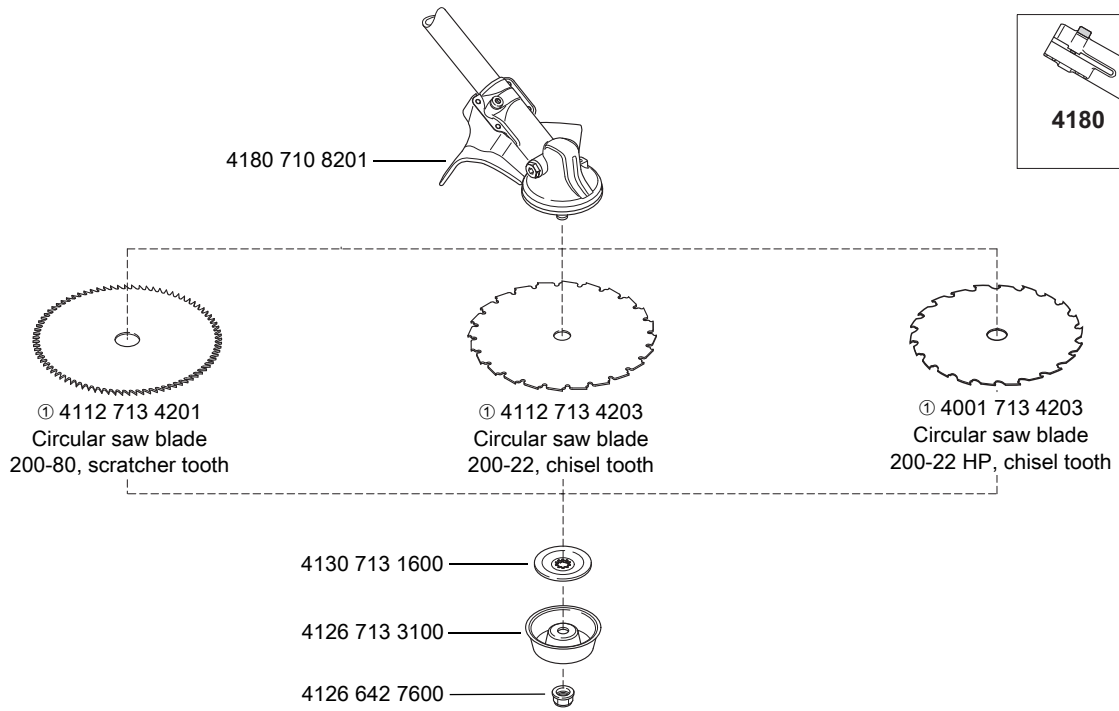

0000-GXX-5706-A0

① Not approved on brushcutters with loop handle

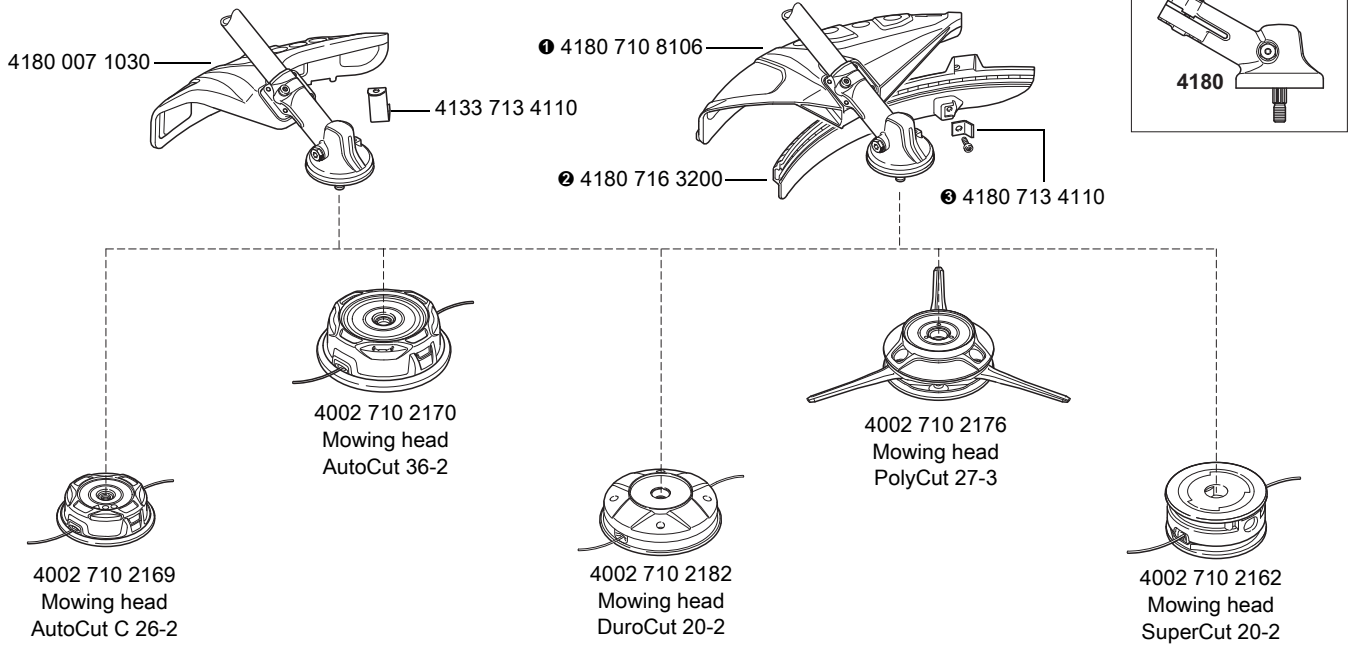

0000-GXX-8234-A0

❶ + ❷ + ❸ = 4180 007 1028

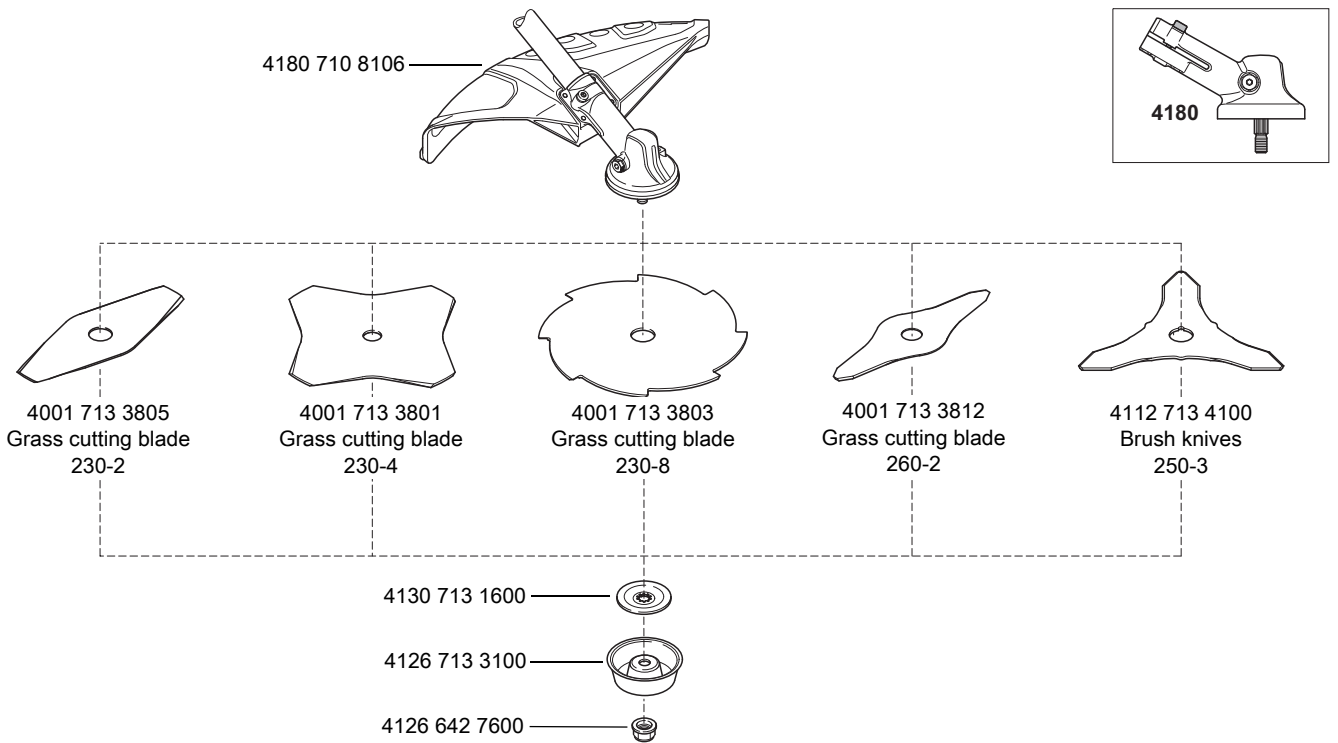

0000-GXX-8235-A0

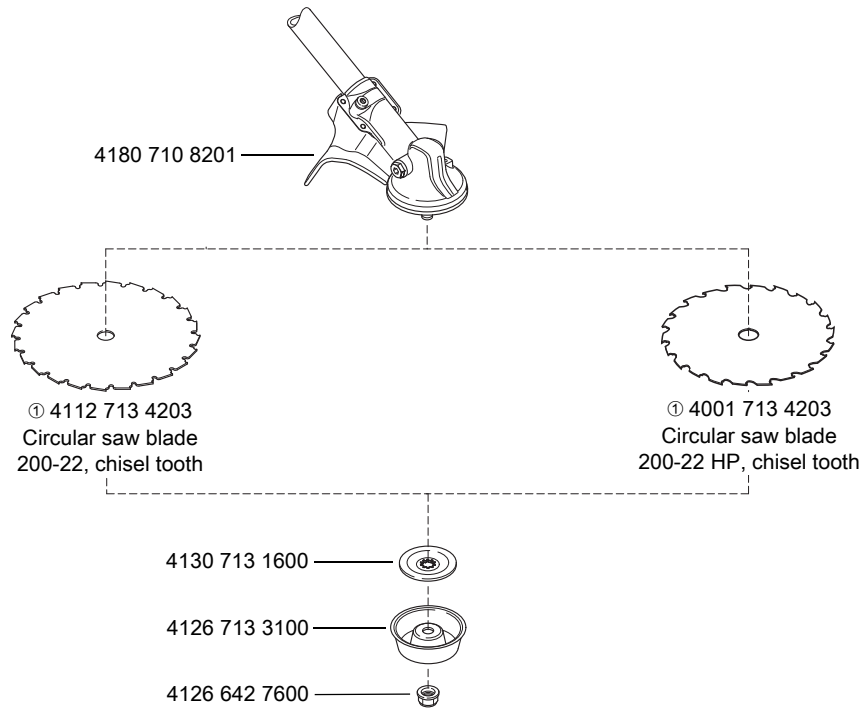

0000-GXX-8236-A0

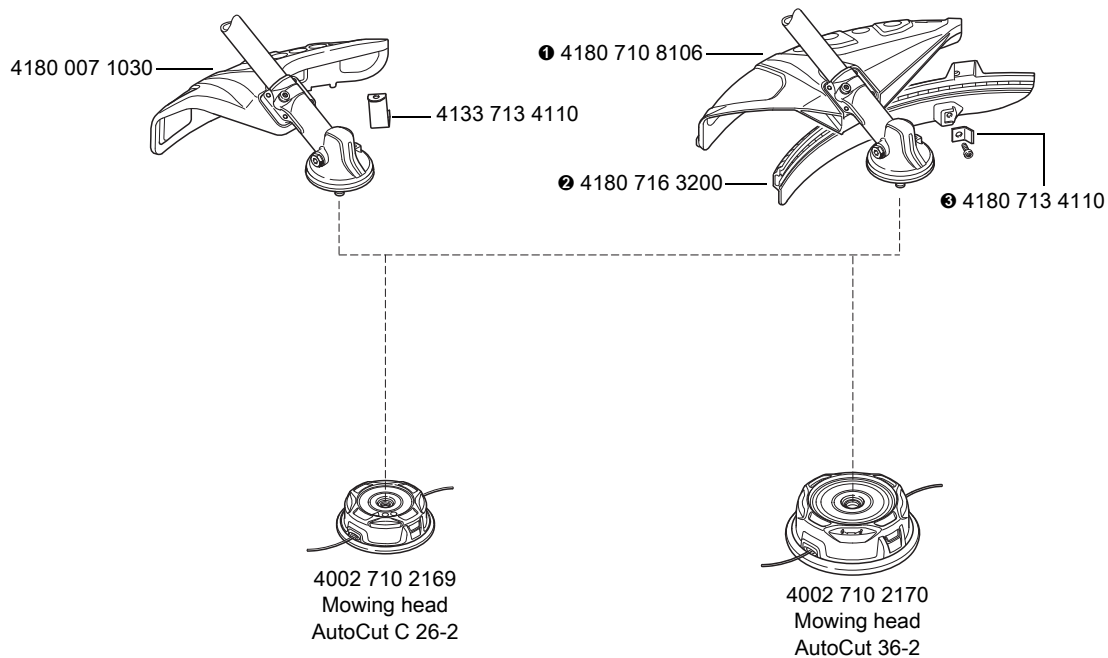

0000-GXX-8233-A0

❶ + ❷ + ❸ = 4180 007 1028

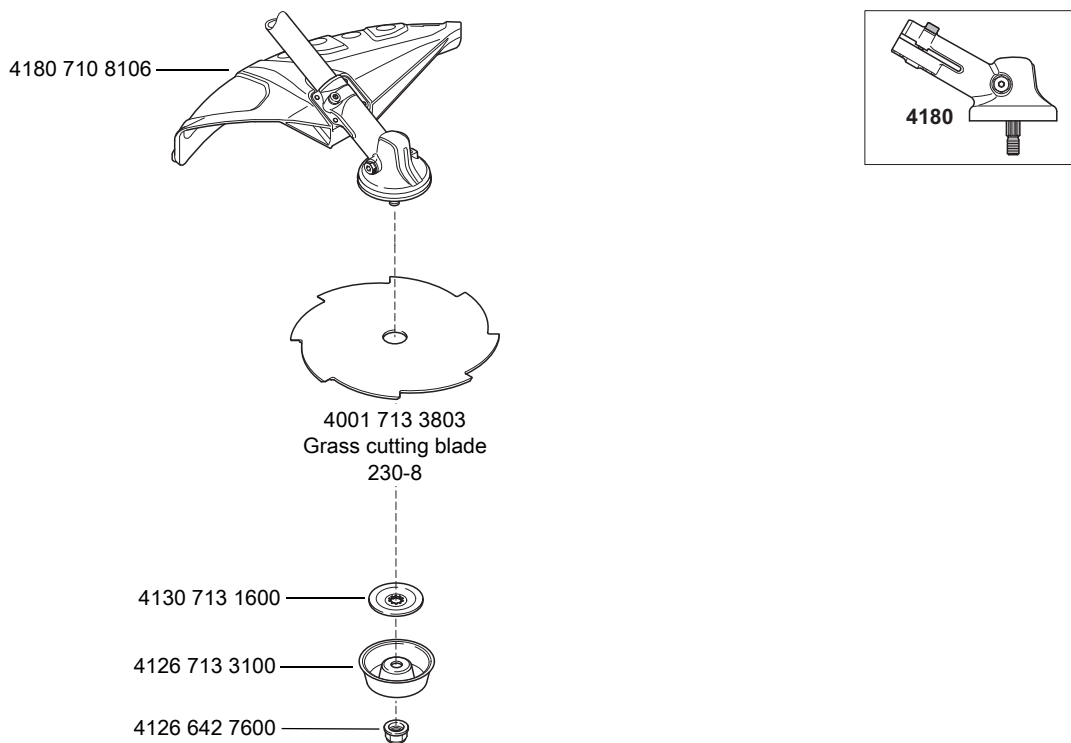

0000-GXX-8232-A0

(a) from 1997 (b) FS 260 with bike handle: page 85 (c) from 2010

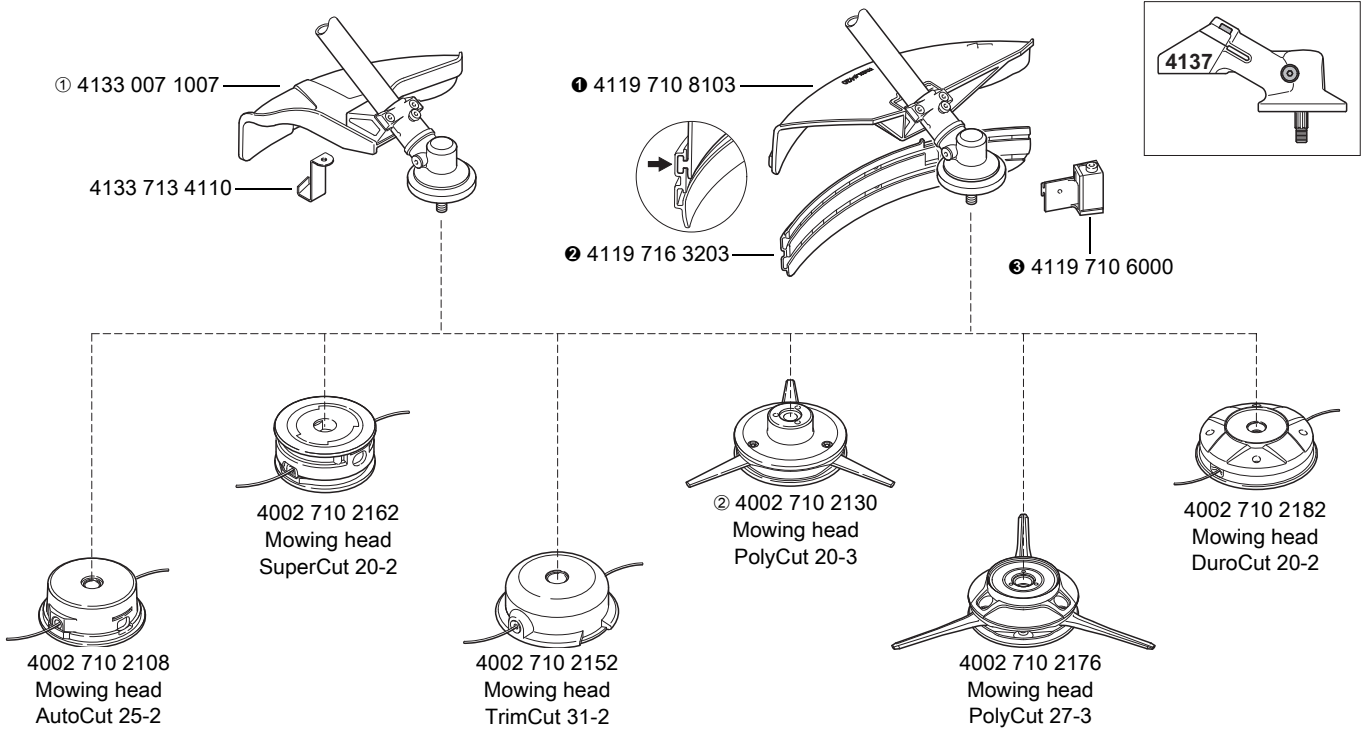

0000-GXX-5740-A0

① Approved in AUS, NZ only: 4133 007 1008

② No longer available

① + ② + ③ = 4119 007 1027

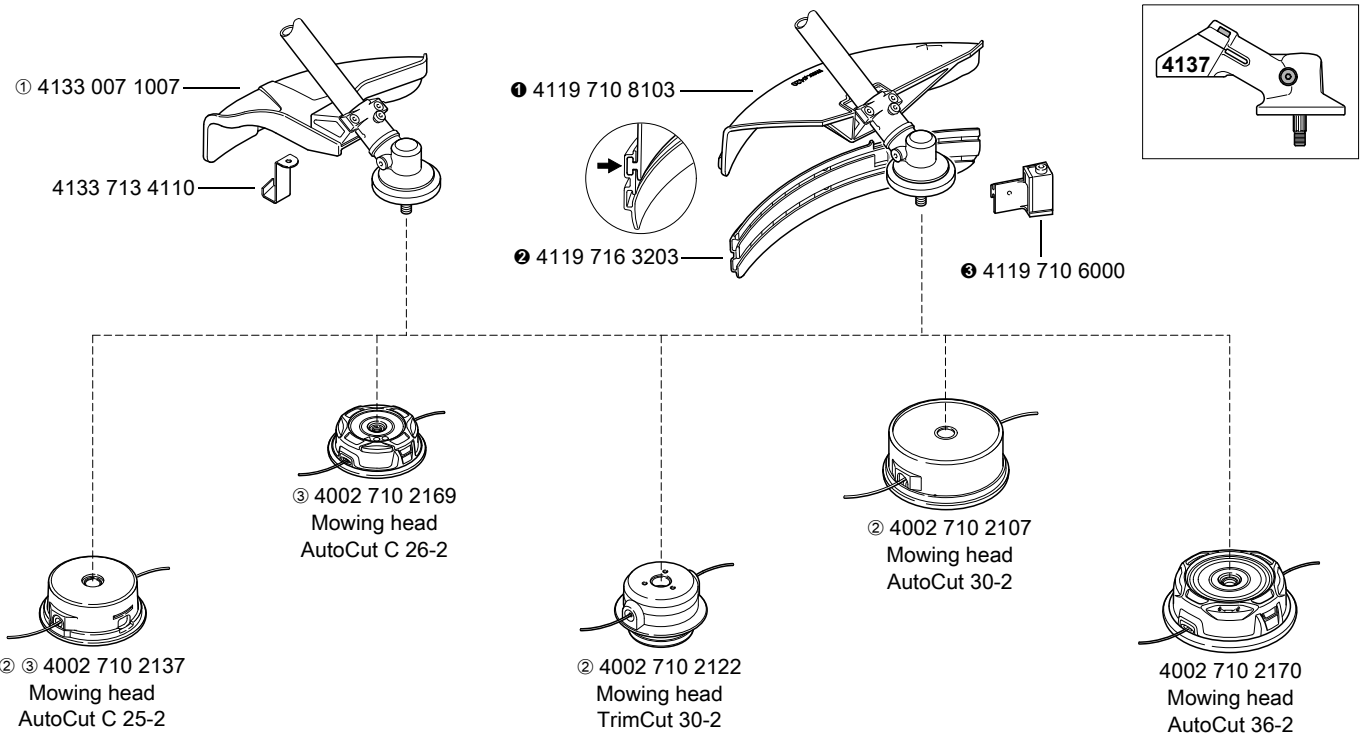

0000-GXX-3458-A0

① Approved in AUS, NZ only: 4133 007 1008

① + ② + ③ = 4119 007 1027

② No longer available

③ Not approved for FS 120, 200, 240, 250, 260 R, 460 R

(a) from 1997 (b) FS 260 with bike handle: page 85 (c) from 2010

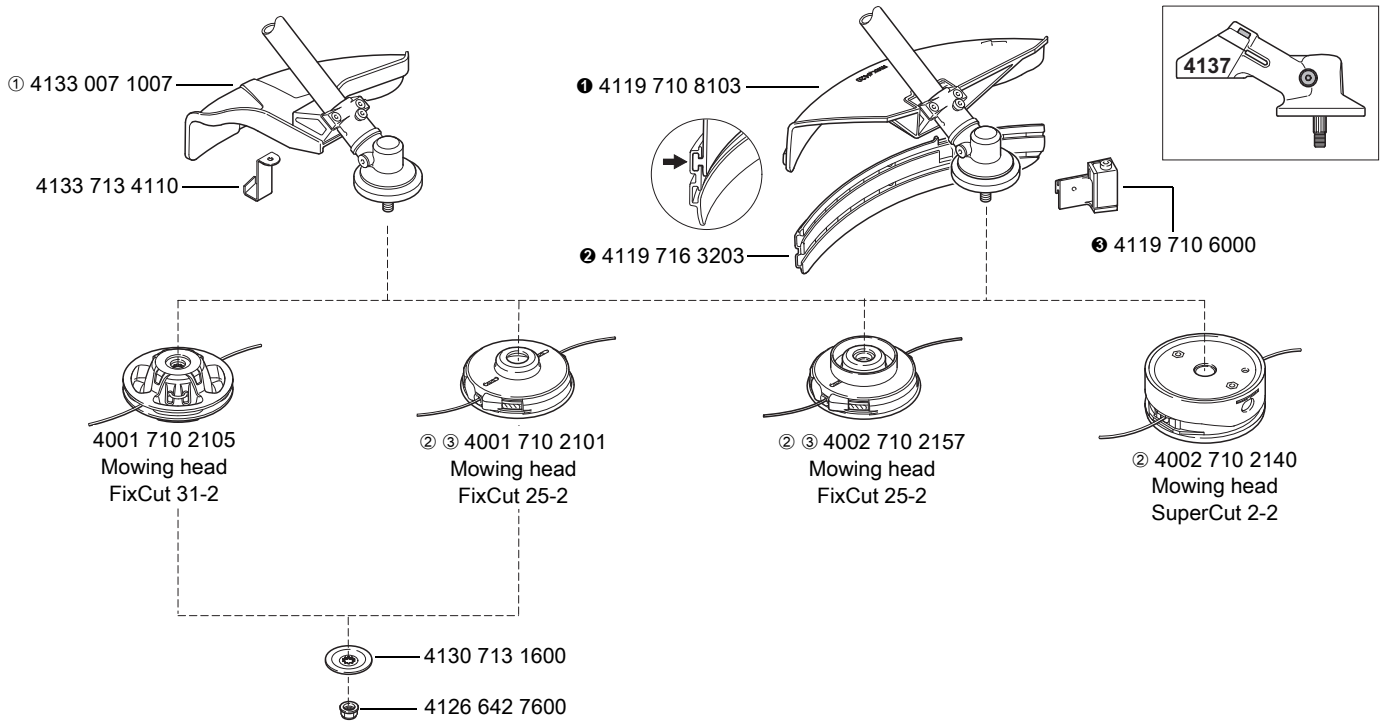

0000-GXX-5707-A0

① Approved in AUS, NZ only: 4133 007 1008

① + ② + ③ = 4119 007 1027

② No longer available

③ Not approved for FS 240, 240 R, 260 R, 460 R

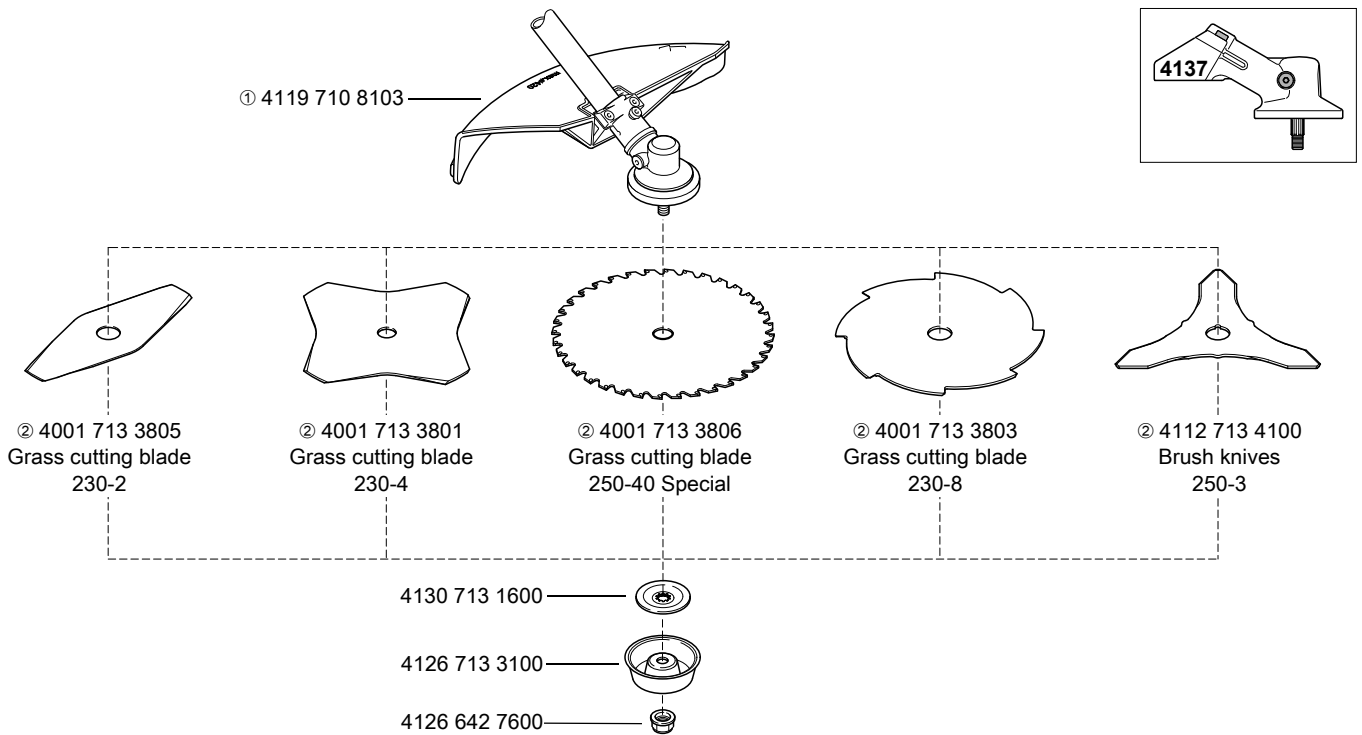

681KT1072 KN

① Deflector for AUS, NZ see illustration marked "AUS, NZ"

② Not approved for FS 200 R, 250 R in EU

(a) from 1997 (b) FS 260 with bike handle: page 85 (c) from 2010

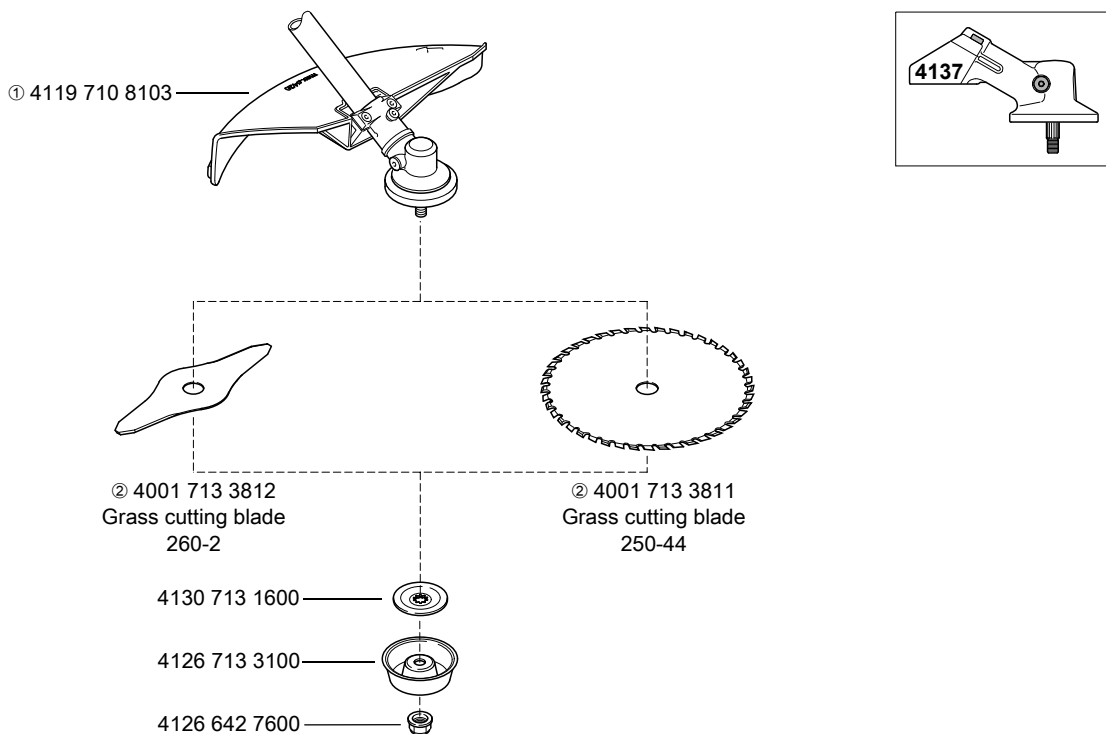

681KT1073 KN

① Deflector for AUS, NZ see illustration marked "AUS, NZ"

② Not approved for FS 200 R, 250 R in EU

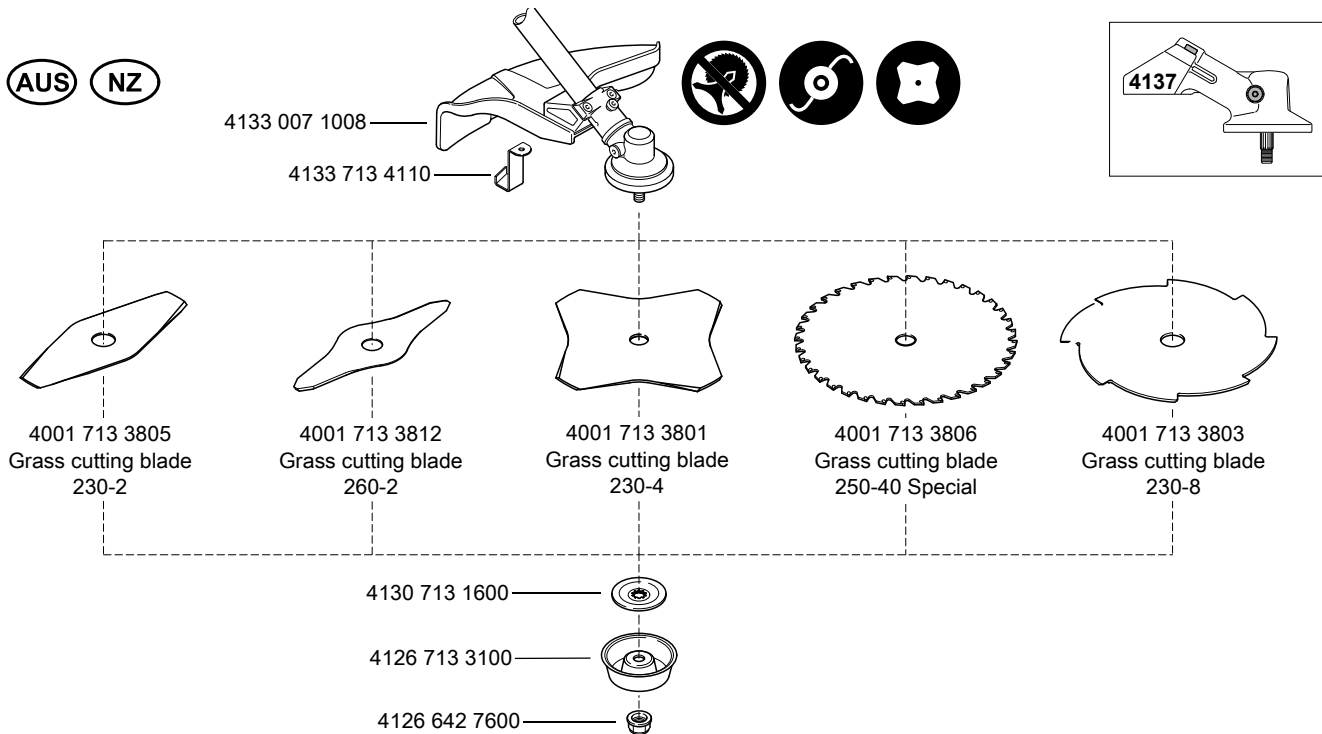

681KT1074 KN

(a) from 1997 (b) FS 260 with bike handle: page 85 (c) from 2010

AUS NZ

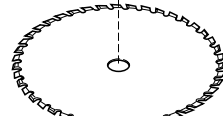
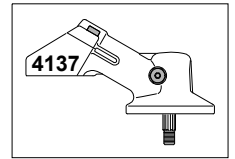
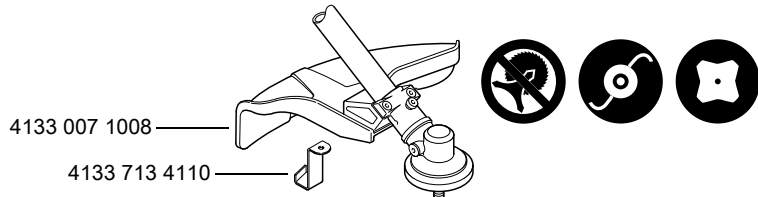

4001 713 3811
Grass cutting blade
250-44

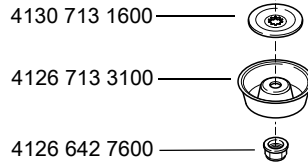

681KT118 KN

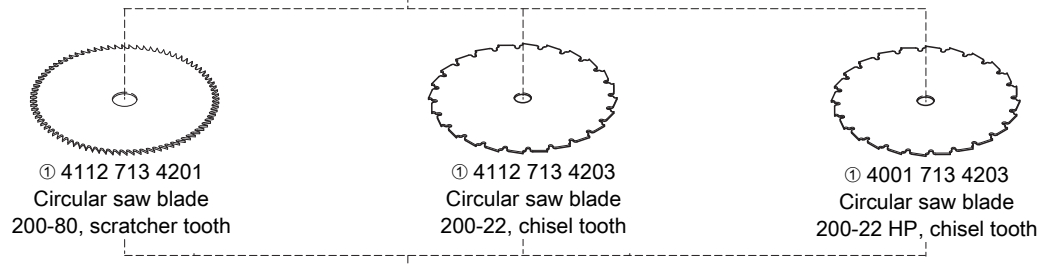
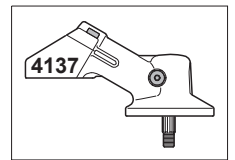
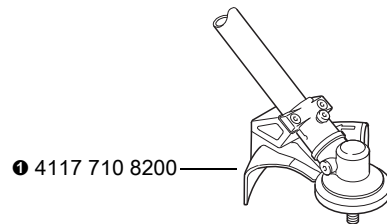

① 4112 713 4201
Circular saw blade
200-80, scratcher tooth

① 4112 713 4203
Circular saw blade
200-22, chisel tooth

① 4001 713 4203
Circular saw blade
200-22 HP, chisel tooth

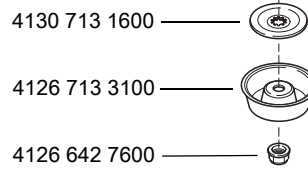

381KT1075-A1

① Not approved on brushcutters with loop handle

① + Transport guard = 4126 007 1002

(a) from 2015

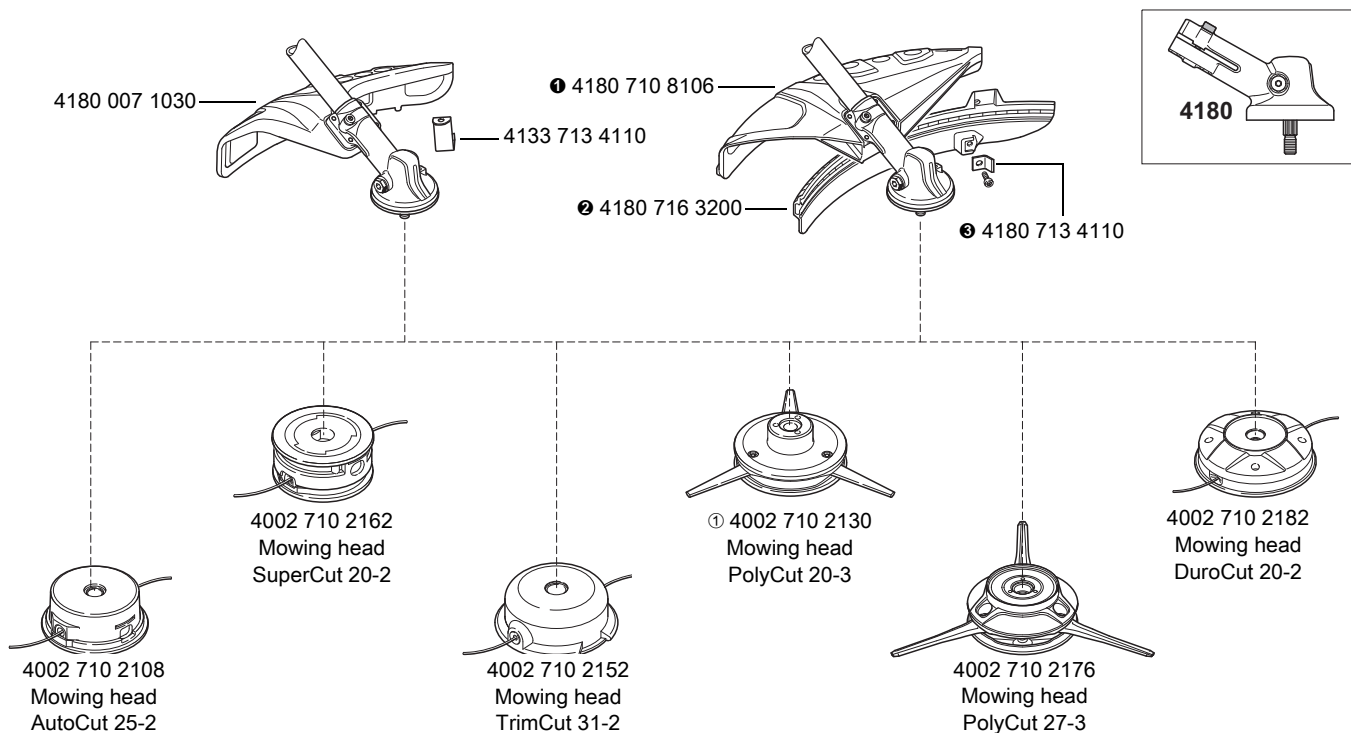

0000-GXX-5741-A0

① No longer available

① + ② + ③ = 4180 007 1028

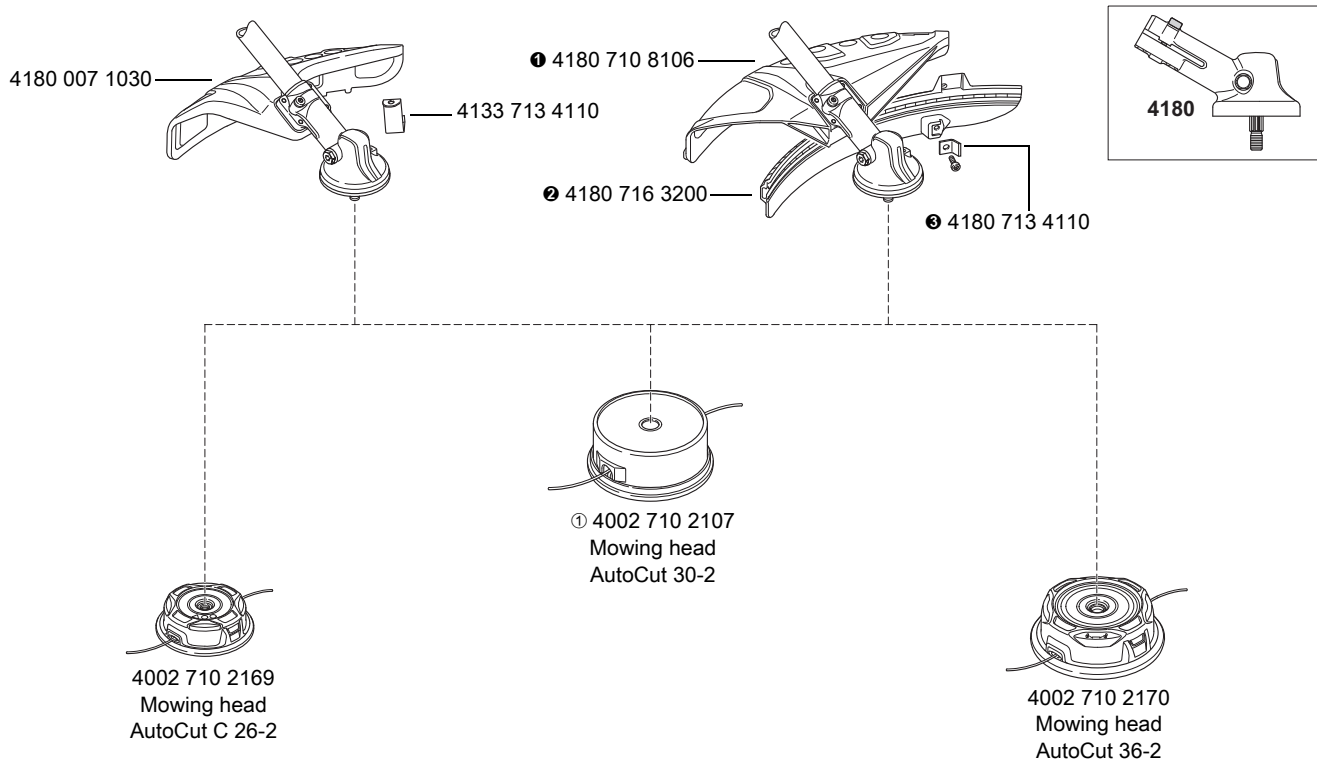

0000-GXX-3467-A0

① No longer available

① + ② + ③ = 4180 007 1028

(a) from 2015

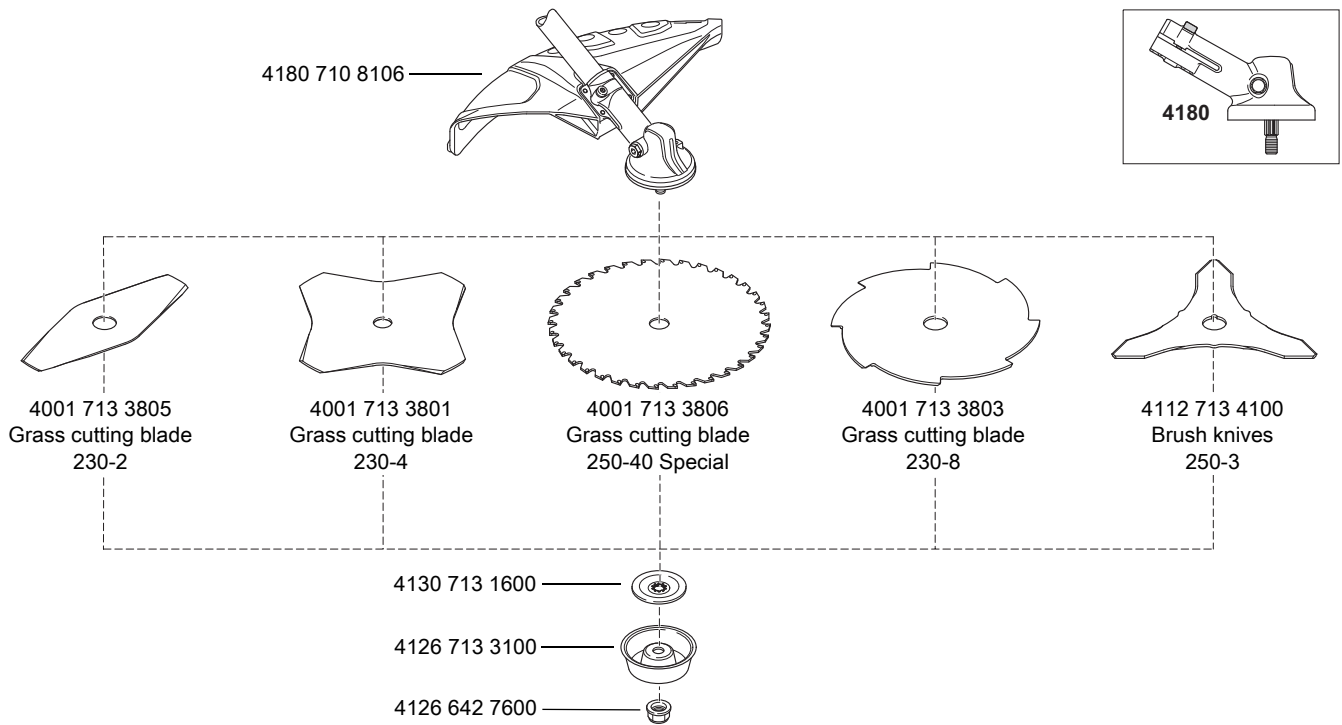

0000-GXX-4207-A0

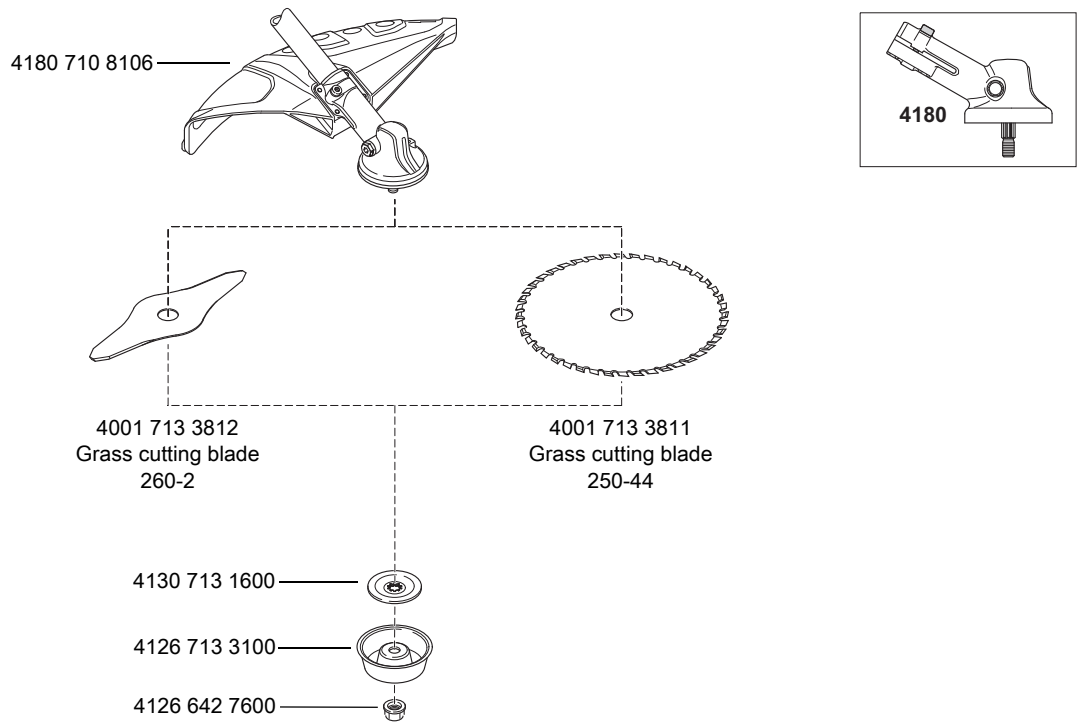

0000-GXX-4208-A0

(a) from 2015

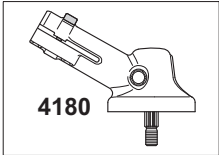
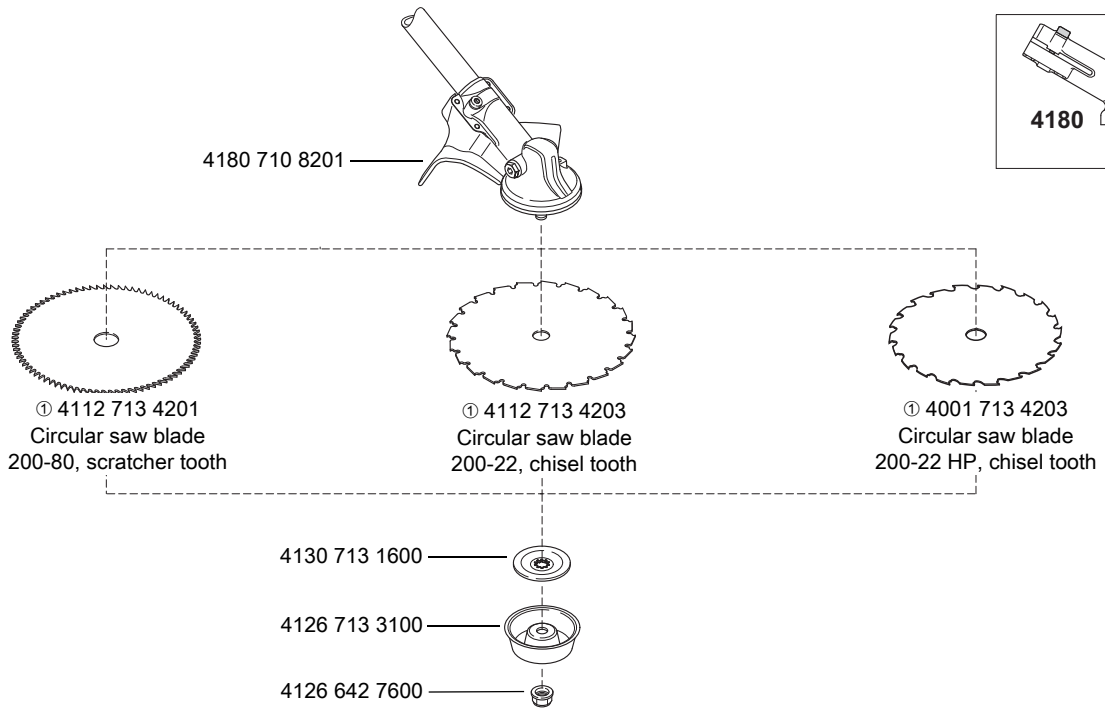

0000-GXX-5708-A0

① Not approved on brushcutters with loop handle

(a) up to 1988 (b) up to 1986

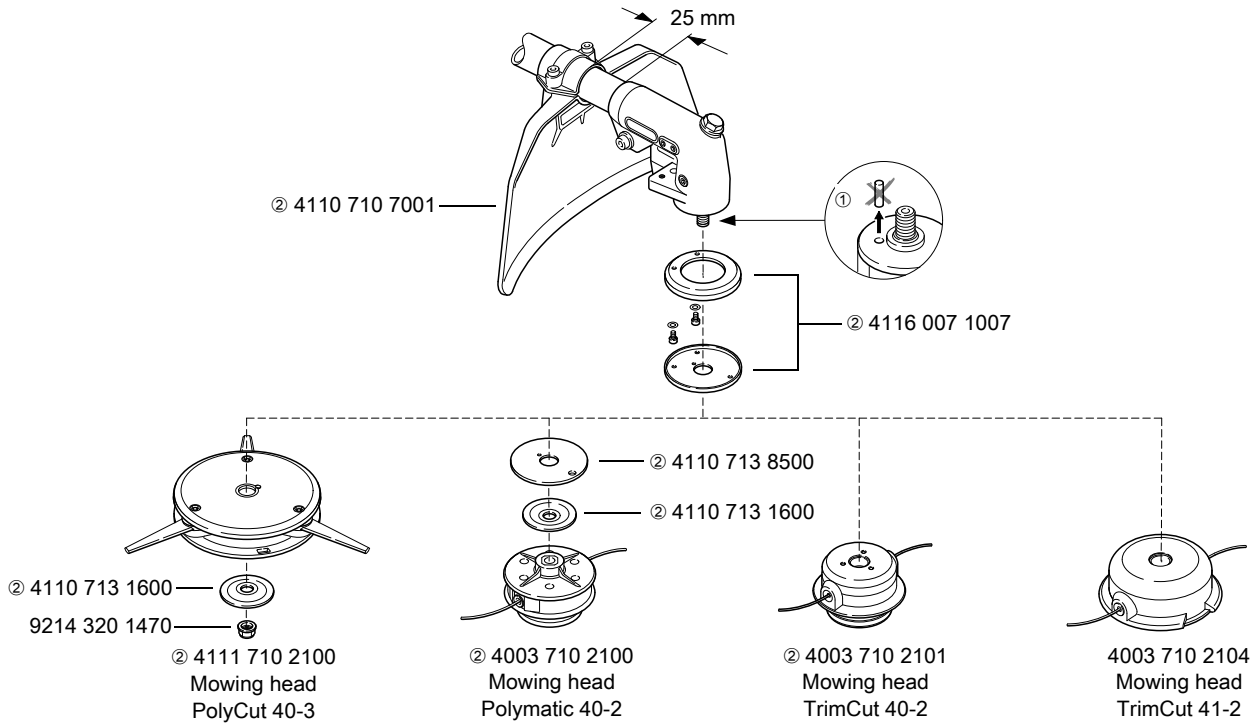

681KT527 KN

① For TrimCut 40-2, TrimCut 41-2

② No longer available

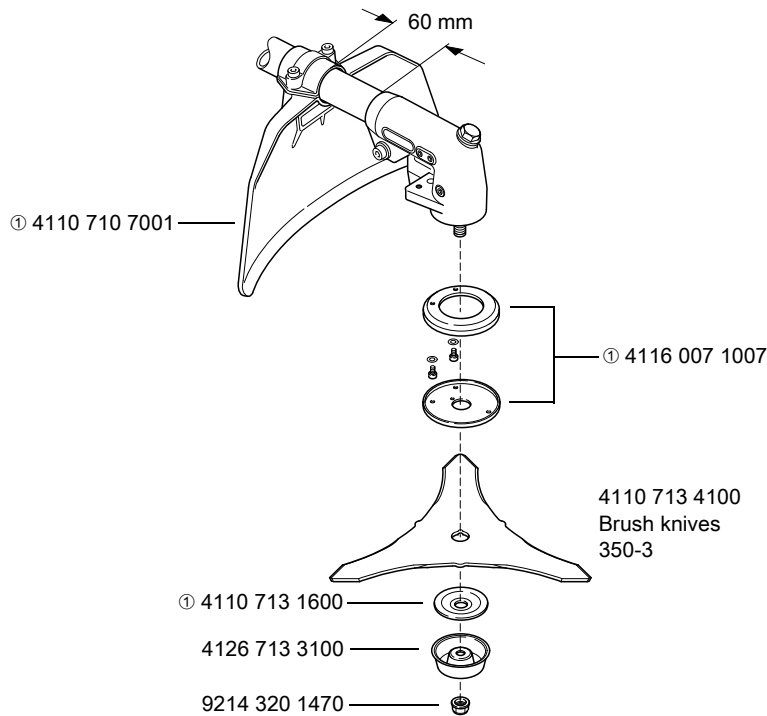

681KT866 KN

① No longer available

(a) up to 1988 (b) up to 1986

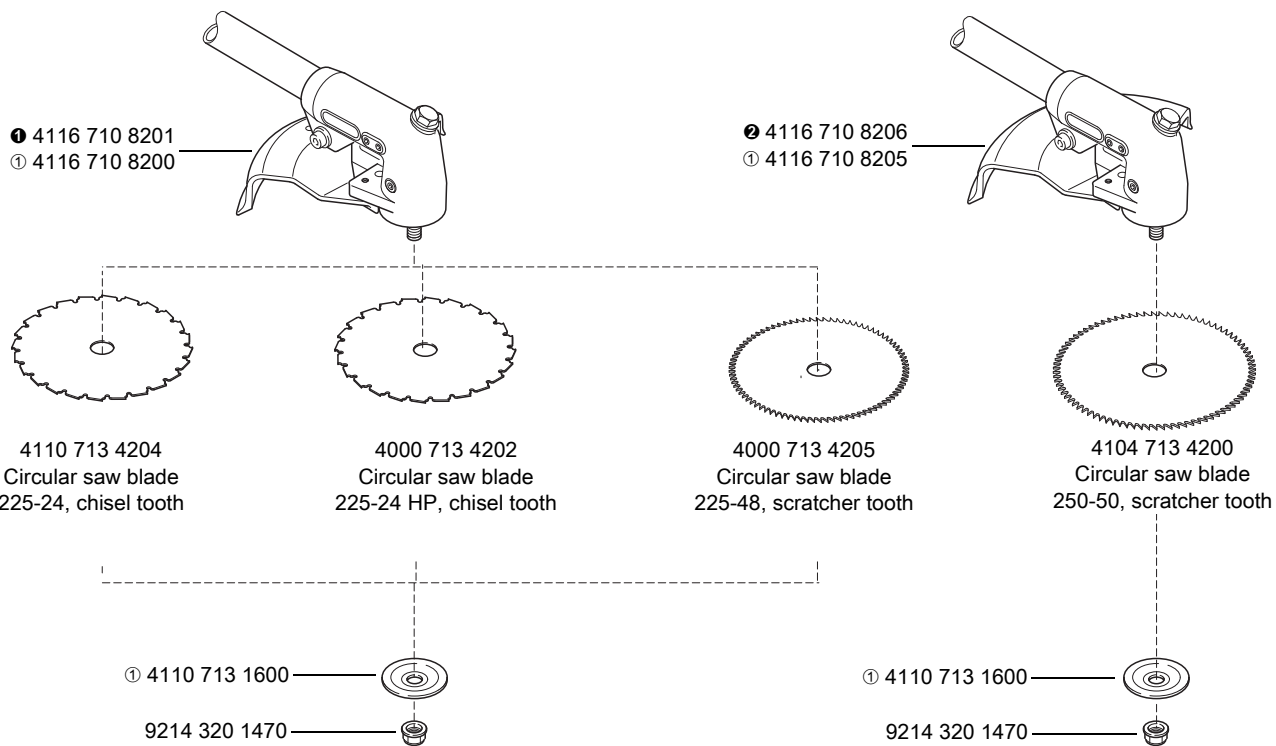

① No longer available

① + Transport guard = 4116 007 1019

② + Transport guard = 4116 710 1018

681KT528-A1

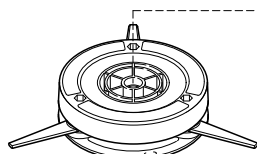
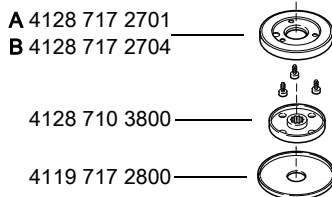
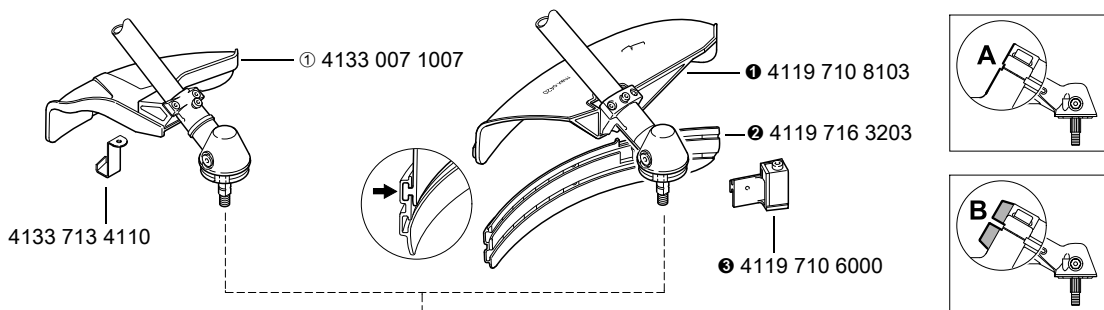
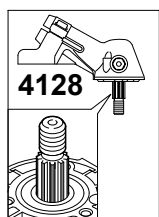

③ 4003 710 2113
Mowing head
PolyCut 41-3

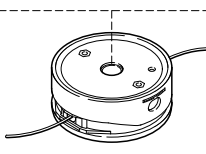

③ 4003 710 2140
Mowing head
SuperCut 40-2

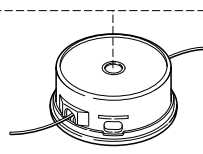

③ 4003 710 2125
Mowing head
AutoCut 40-2

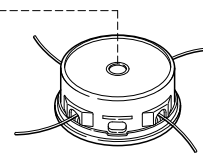

② ③ 4005 710 2100
Mowing head
AutoCut 40-4

681KT575 KN

① Approved in AUS, NZ only: 4133 007 1008

① + ② + ③ = 4119 007 1027

② Not approved for FS 160, 220, 300, 310, 350, 400

③ No longer available

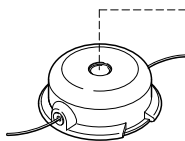
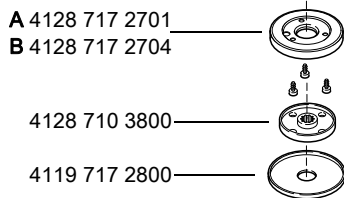
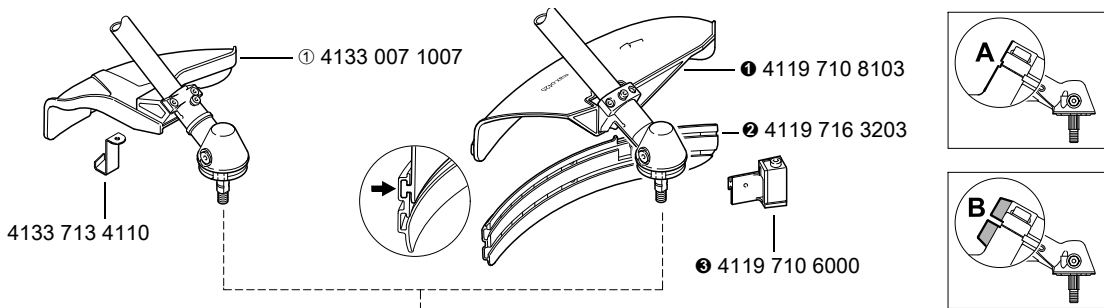
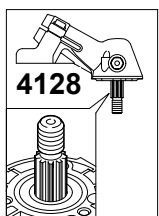

4003 710 2104
Mowing head
TrimCut 41-2

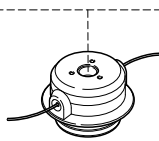

② 4003 710 2101
Mowing head
TrimCut 40-2

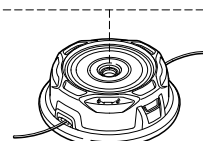

4003 710 2115
Mowing head
AutoCut 46-2

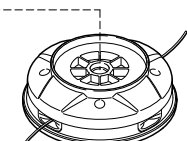

4005 710 2114
Mowing head
DuroCut 40-4

681KT1081 KN

① Approved in AUS, NZ only: 4133 007 1008

② No longer available

① + ② + ③ = 4119 007 1027

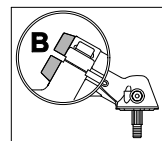
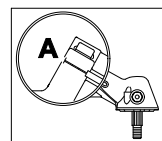
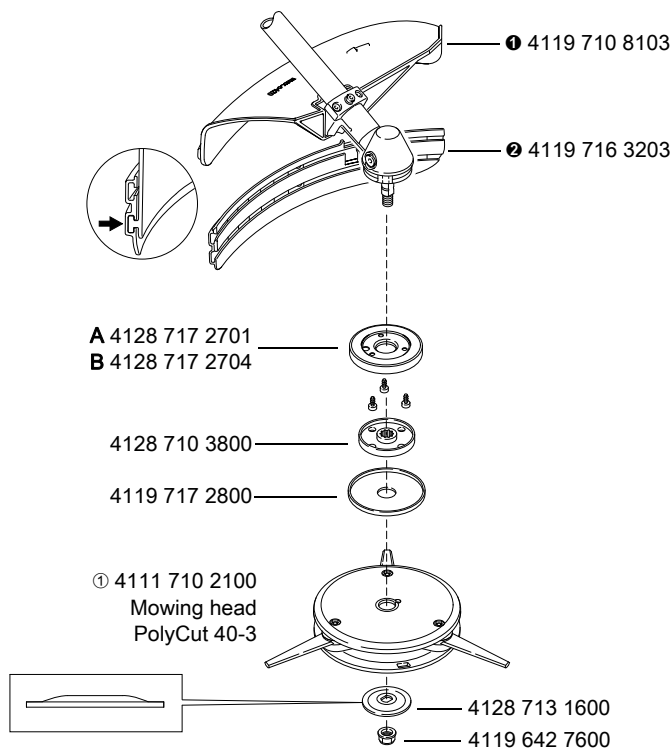
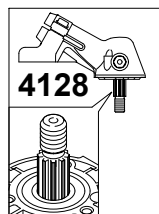

A 4128 717 2701
B 4128 717 2704

4128 710 3800

4119 717 2800

① 4111 710 2100
Mowing head
PolyCut 40-3

4128 713 1600

4119 642 7600

681KT807 KN

① No longer available

① + ② = 4119 007 1027

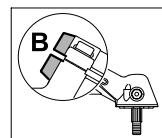
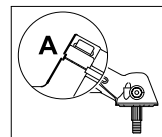
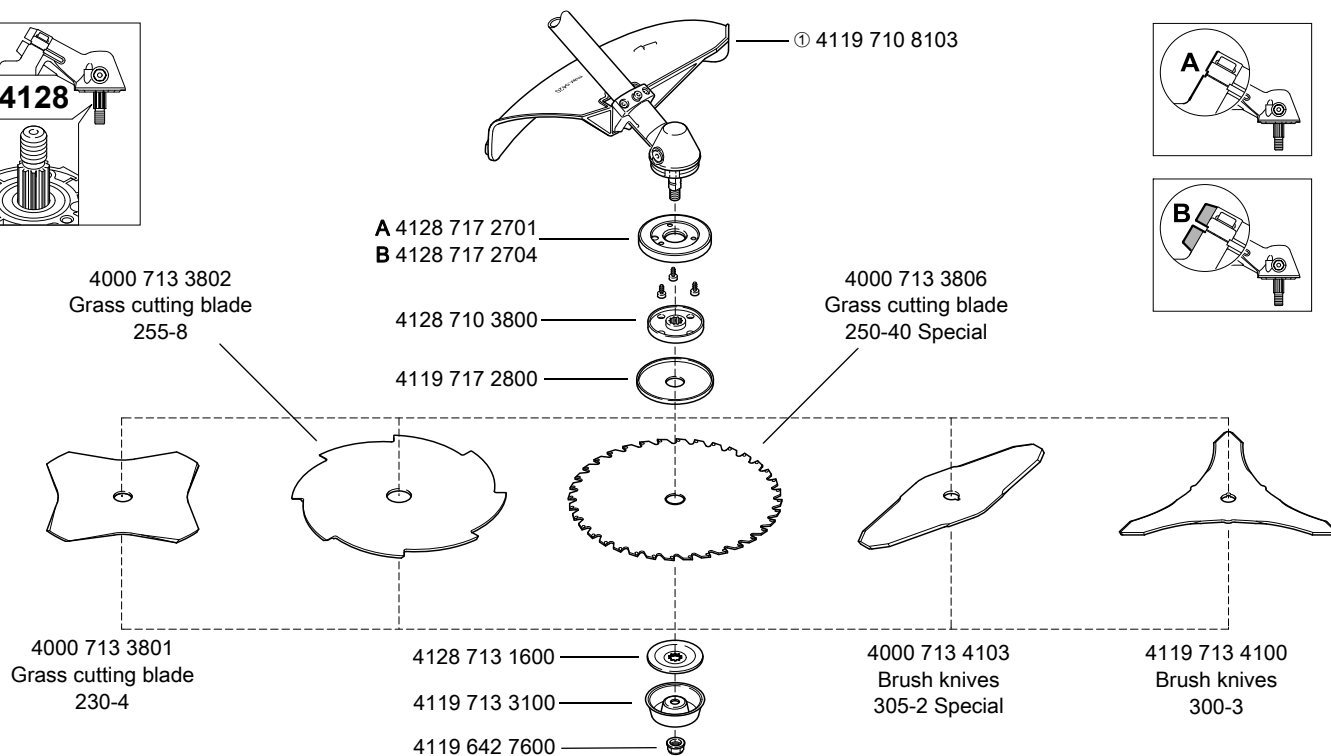
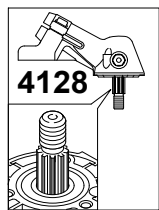

A 4128 717 2701
B 4128 717 2704

4128 710 3800

4119 717 2800

4000 713 3802
Grass cutting blade
255-8

4000 713 3806
Grass cutting blade
250-40 Special

4000 713 3801
Grass cutting blade
230-4

4128 713 1600

4119 713 3100

4119 642 7600

4000 713 4103
Brush knives
305-2 Special

4119 713 4100
Brush knives
300-3

681KT576 KN

① Deflector for AUS, NZ see illustration marked "AUS, NZ"

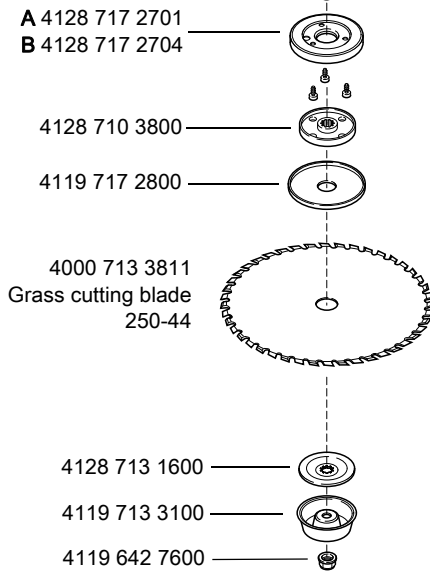
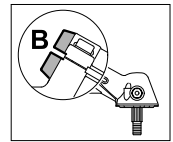
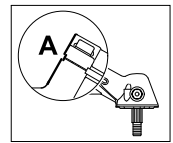
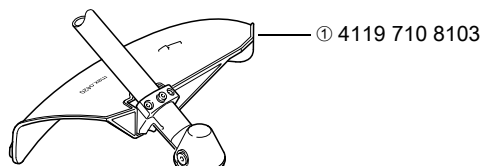
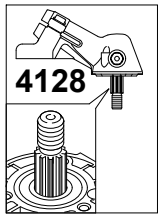

① Deflector for AUS, NZ see illustration marked "AUS, NZ"

681KT1082 KN

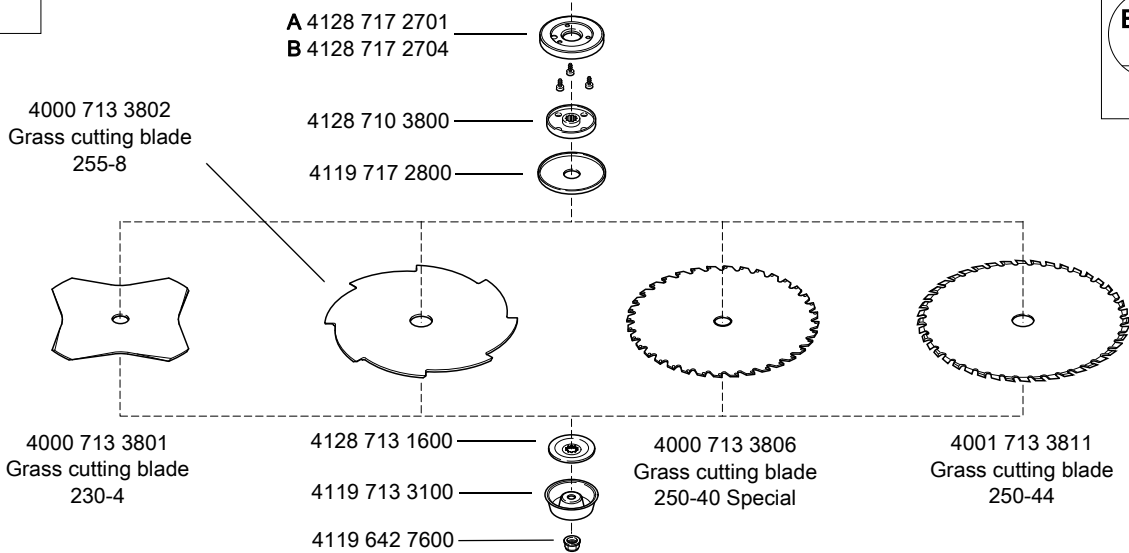
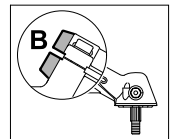
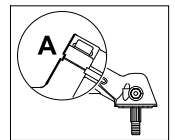
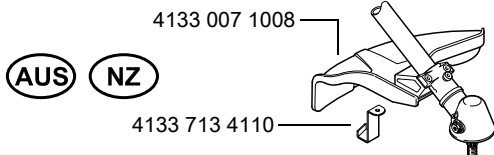
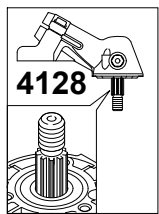

681KT1119 KN

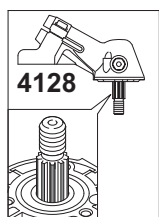

A 4128 717 2706
B 4128 717 2707

4128 710 3800

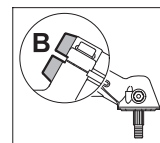
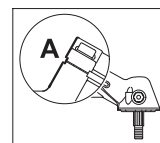

① 4119 713 4200
Circular saw blade
200-22, chisel tooth

① 4000 713 4200
Circular saw blade
200-44, scratcher tooth

① 4000 713 4203
Circular saw blade
200-20 HP, chisel tooth

① ② 4000 713 4202
Circular saw blade
225-20 HP, chisel tooth

4128 713 1600

4119 713 3100

4119 642 7600

0000-GXX-5709-A0

① Not approved on brushcutters with loop handle

② Not approved for FS 310

① + Transport guard = 4126 007 1002

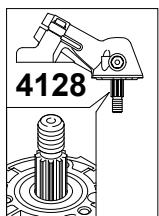

A 4128 717 2706
B 4128 717 2707

4128 710 3800

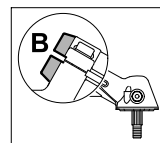
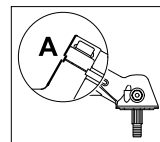

① ② 4000 713 4201
Circular saw blade
225-24, chisel tooth

① ② 4110 713 4204
Circular saw blade
225-24, chisel tooth

① ② 4000 713 4205
Circular saw blade
225-48, scratcher tooth

① ② 4000 713 4211
Circular saw blade
225-36, carbide

4128 713 1600

4119 713 3100

4119 642 7600

681KT868 KN

① Not approved for FS 310

② Not approved on brushcutters with loop handle

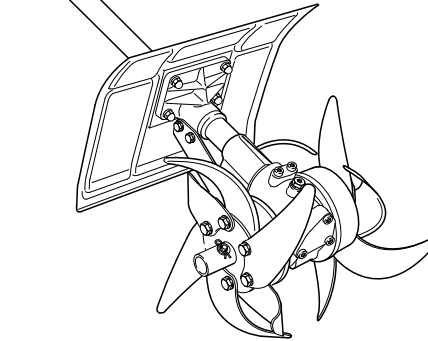
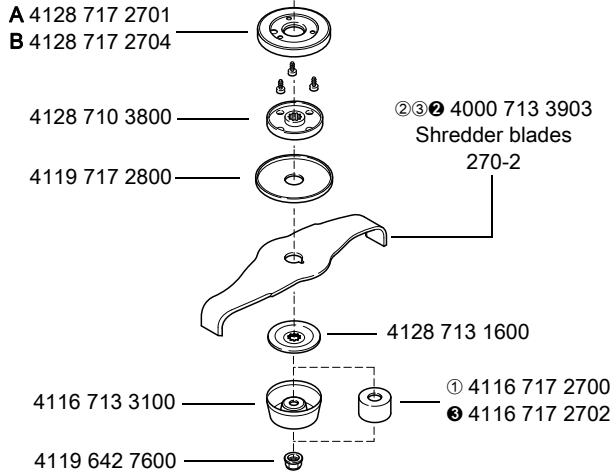
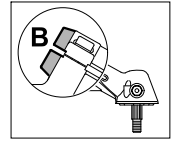
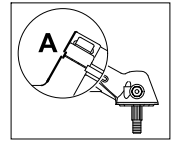
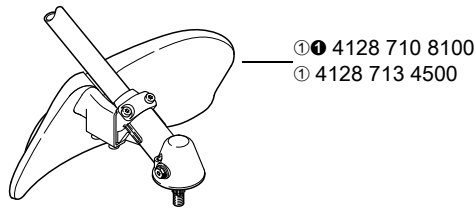
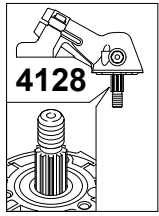

① ② 4600 710 1501
Cultivator BC 40

681K1578-KN

- ① No longer available
- ② Not approved on brushcutters with loop handle
- ③ Approved for FS 160 from serial No. 3 50 609 048

- ① + ② + ③ = 4128 007 1008
- ① + ③ = 4128 007 1007

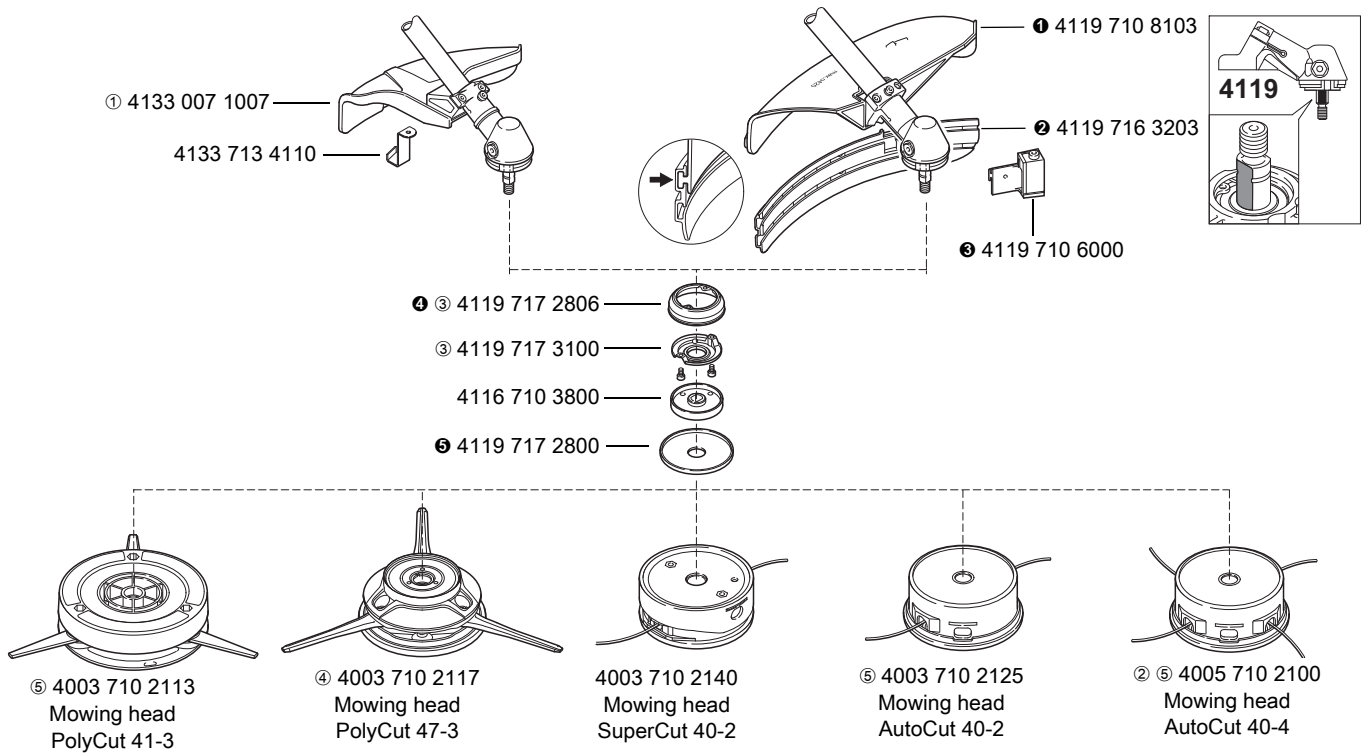

0000-GXX-5742-A0

① Approved in AUS, NZ only: 4133 007 1008

② Not approved for FS 160, 180, 220, 300, 350, 400

③ Only for gearboxes with screwed-on protective ring

④ Not approved for FS 180, 280, 400, 450

⑤ No longer available

① + ② + ③ = 4119 007 1027 / ④ + ⑤ = 4119 007 1021

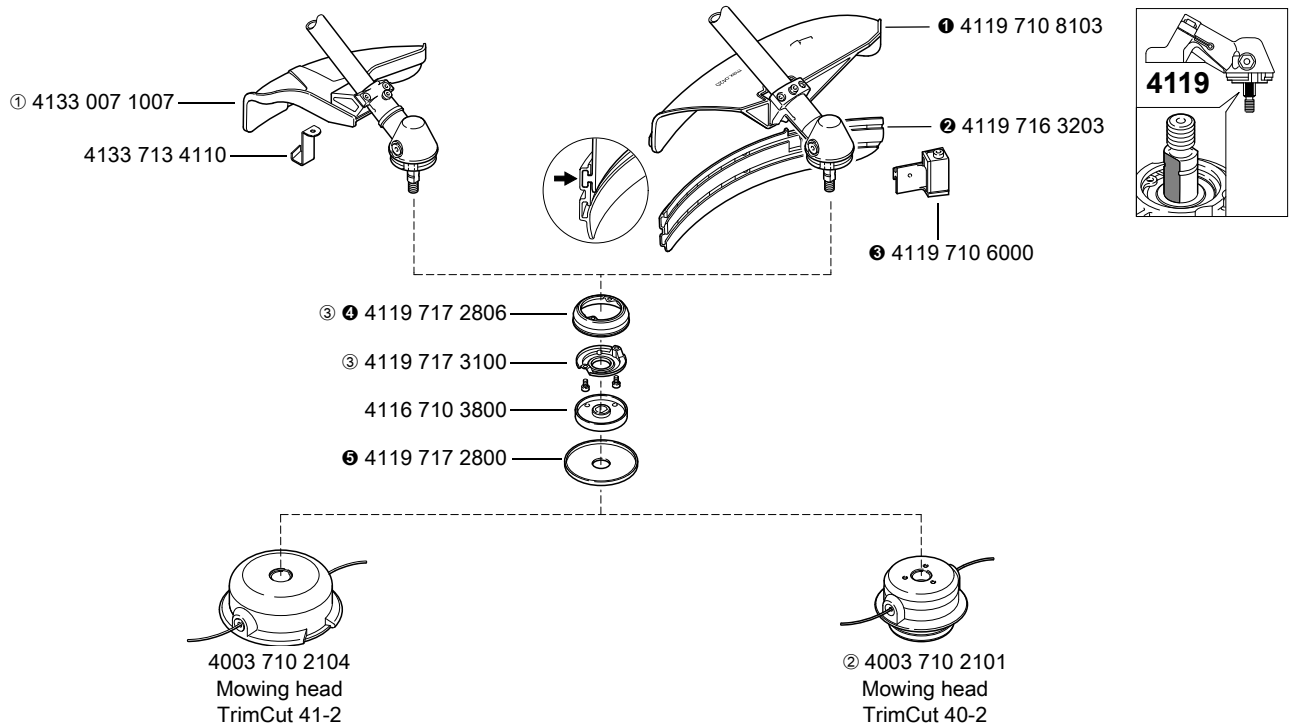

0000-GXX-3468-A0

① Approved in AUS, NZ only: 4133 007 1008

② No longer available

③ Only for gearhead with screw-fitted guard ring

① + ② + ③ = 4119 007 1027

④ + ⑤ = 4119 007 1021

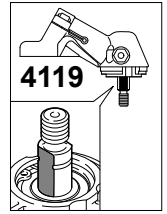
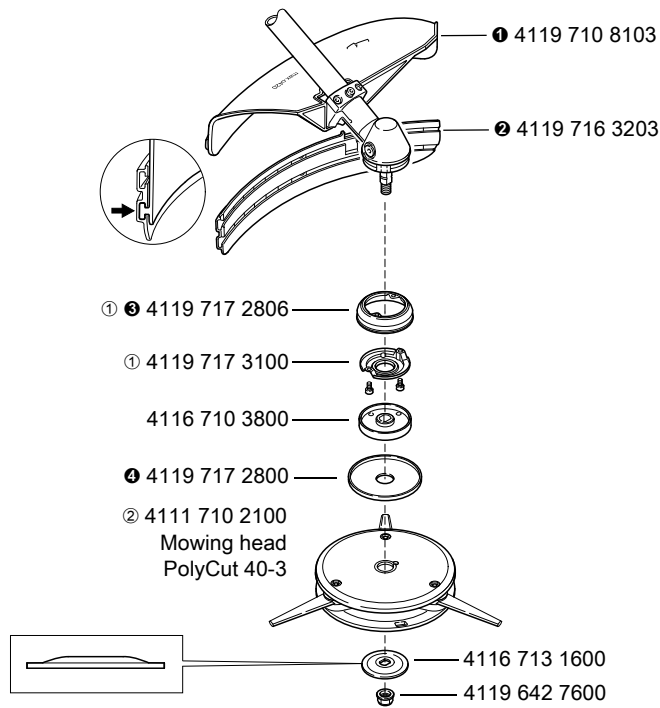

681KT512 KN

① Only for gearhead with screw-fitted guard ring

② No longer available

❶ + ❷ = 4119 007 1027

❸ + ❹ = 4119 007 1021

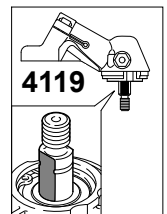
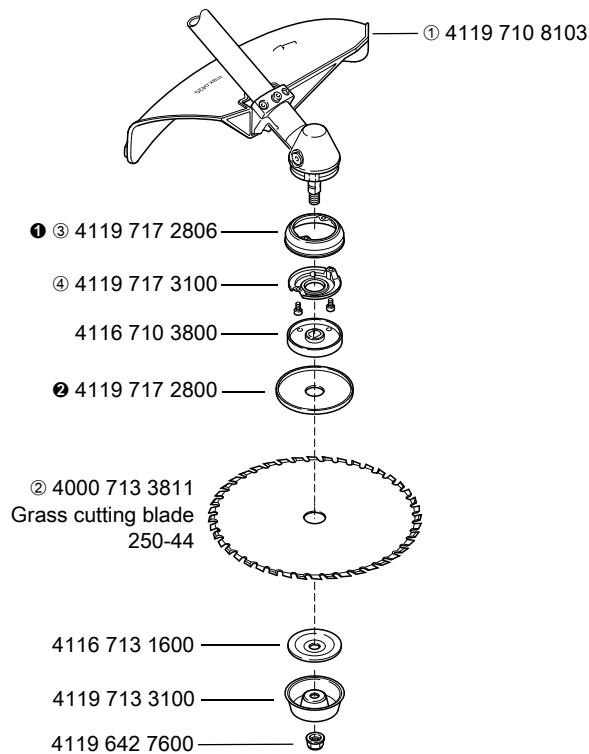

681KT1102 KN

① Deflector for AUS, NZ see illustration marked "AUS, NZ"

② Not approved on brushcutters with loop handle

③ Only for gearhead with screw-fitted guard ring

❶ + ❷ = 4119 007 1021

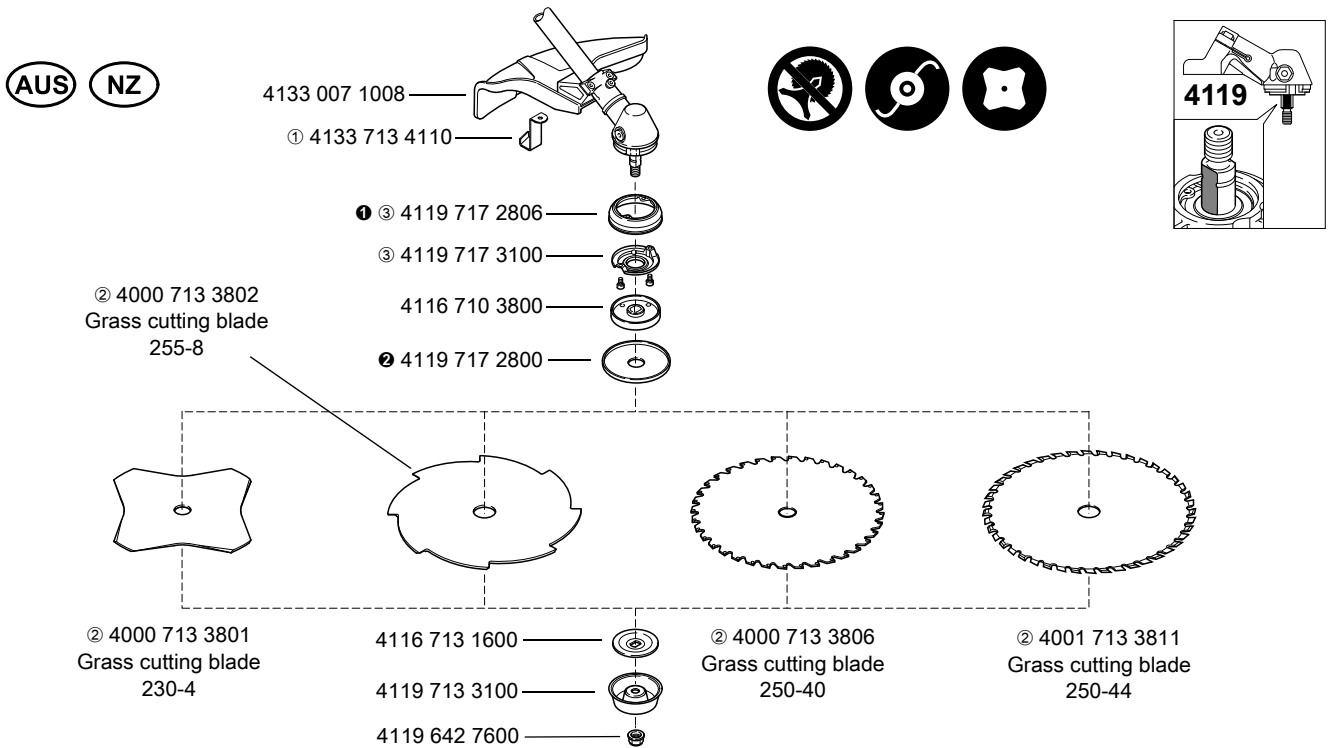

68IKT1120 KN

- ① Part is included with deflector
- ② Not approved on brushcutters with loop handle
- ③ Only for gearhead with screw-fitted guard ring
- ① + ② = 4119 007 1021

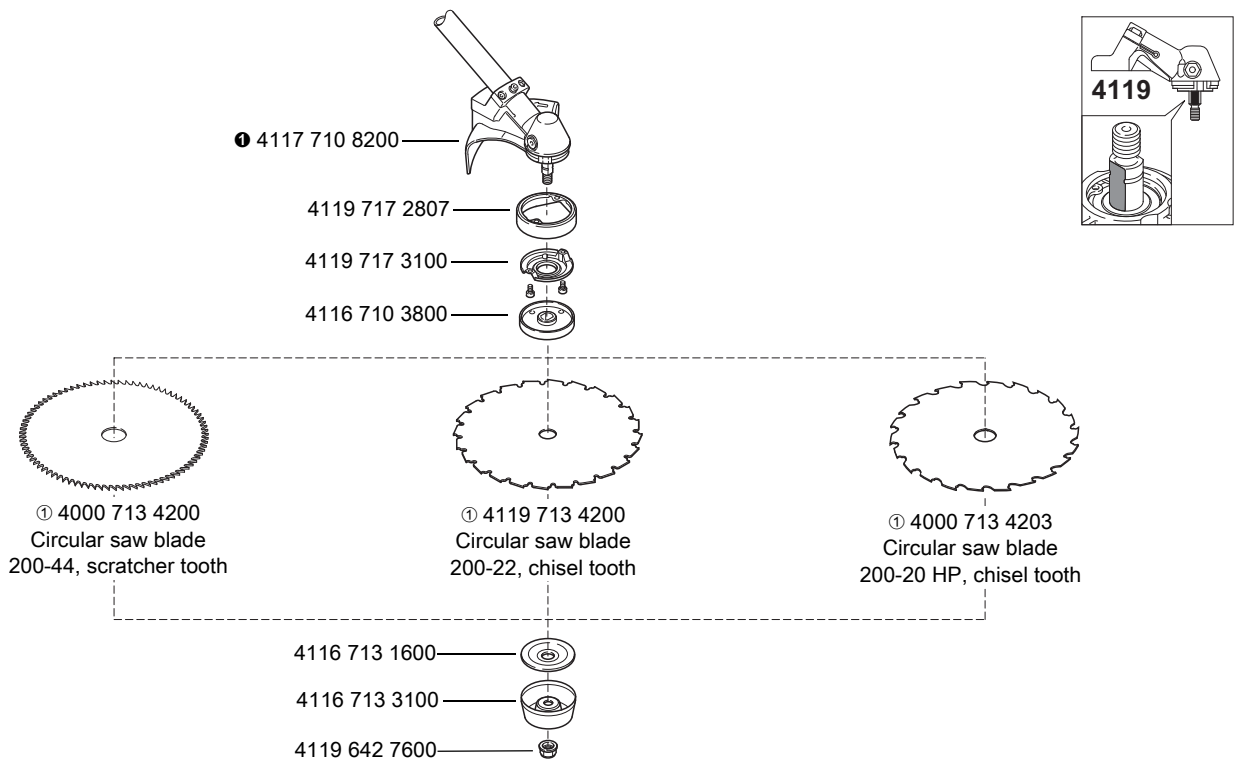

0000-GXX-5710-A0

- ① Not approved on brushcutters with loop handle
- ① + Transport guard = 4126 007 1002

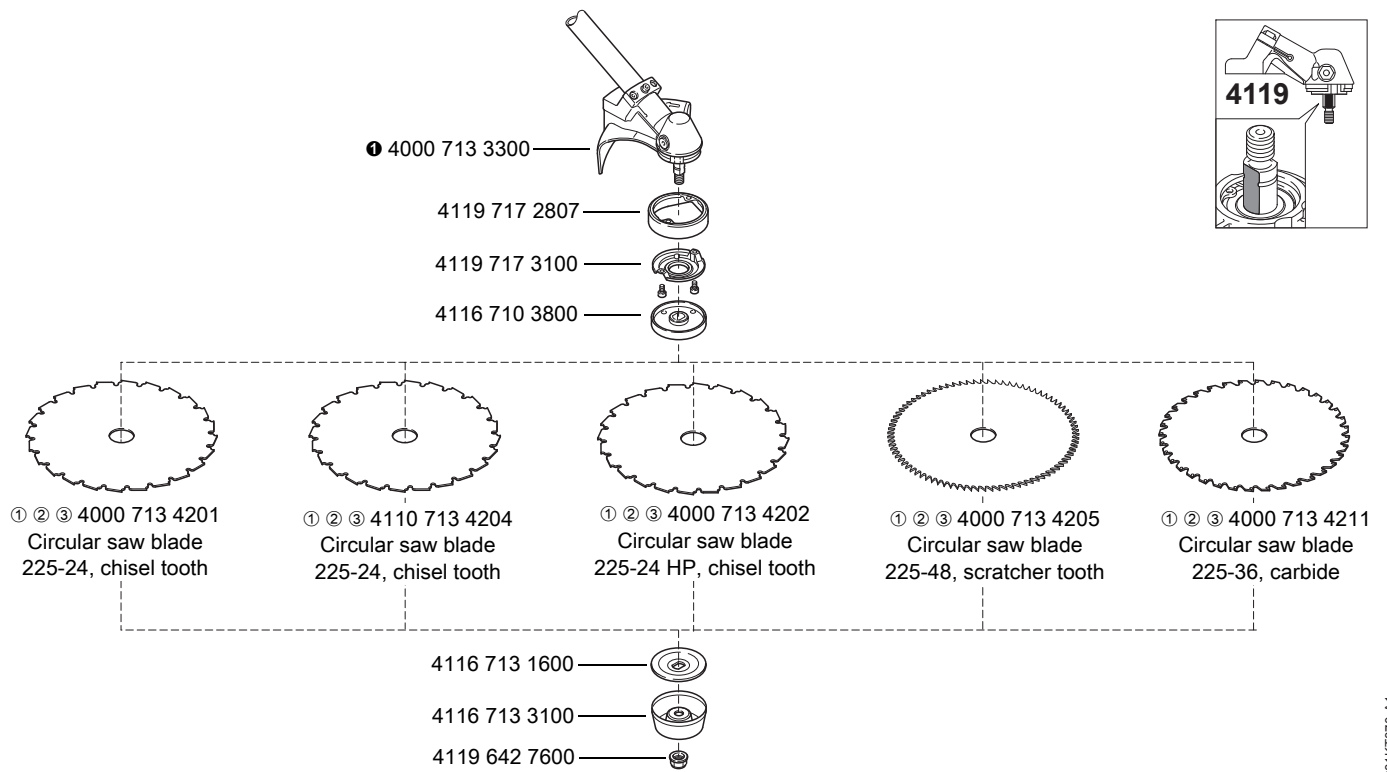

681KT870-A1

① Not approved for FS 300, 350

① + Transport guard = 4119 007 1009

② Approved in Brazil from 2014

③ Not approved on brushcutters with loop handle

(a) FS 260 R, 460 R: page 67 (b) from 2010 (c) FS 410 K, 460 K, 490 K: page 91

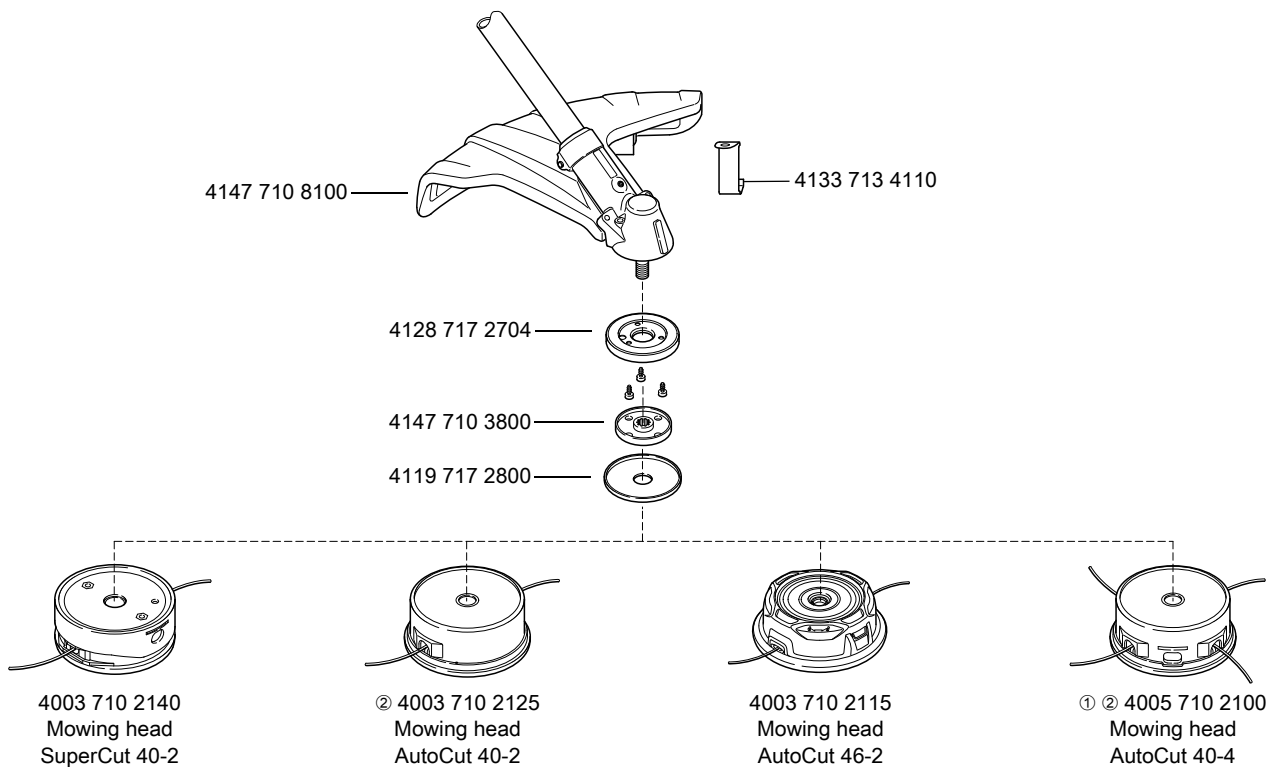

681KT1084 KN

① Not approved for FS 260, 311, 360, 410

② No longer available

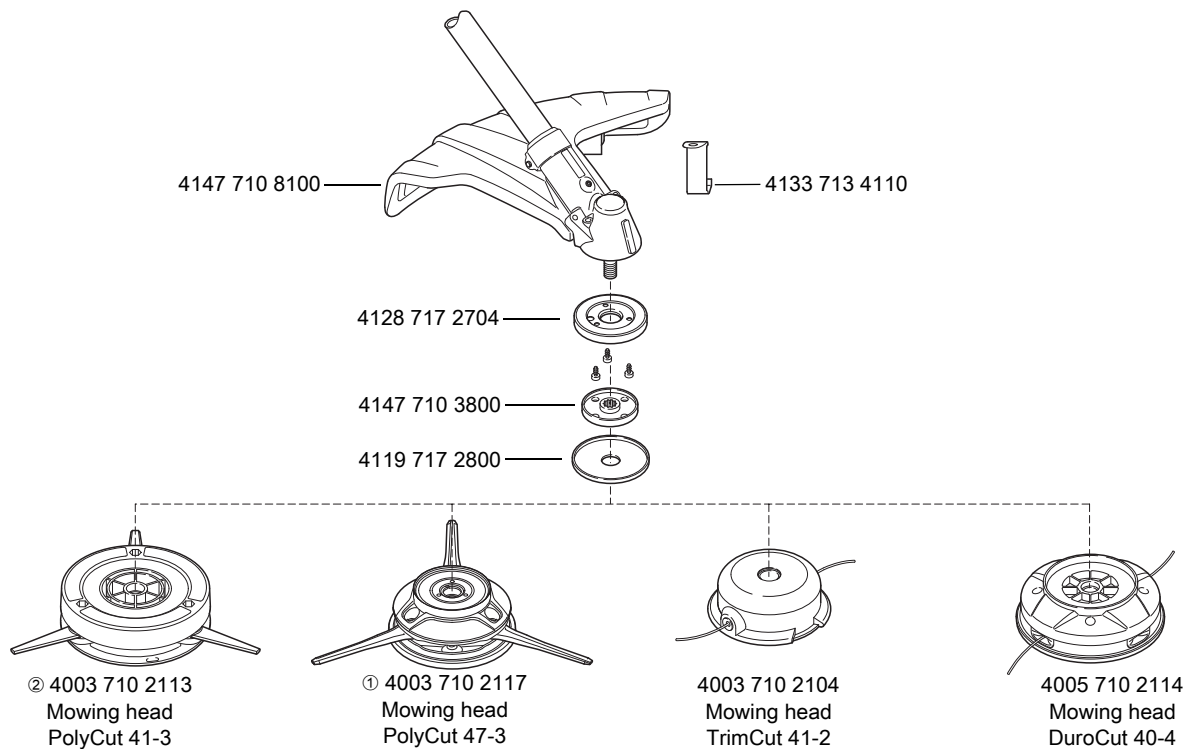

3000-GXX-5743-A0

① Not approved for FS 260, 410

② No longer available

(a) FS 260 R, 460 R: page 67 (b) from 2010 (c) FS 410 K, 460 K, 490 K: page 91

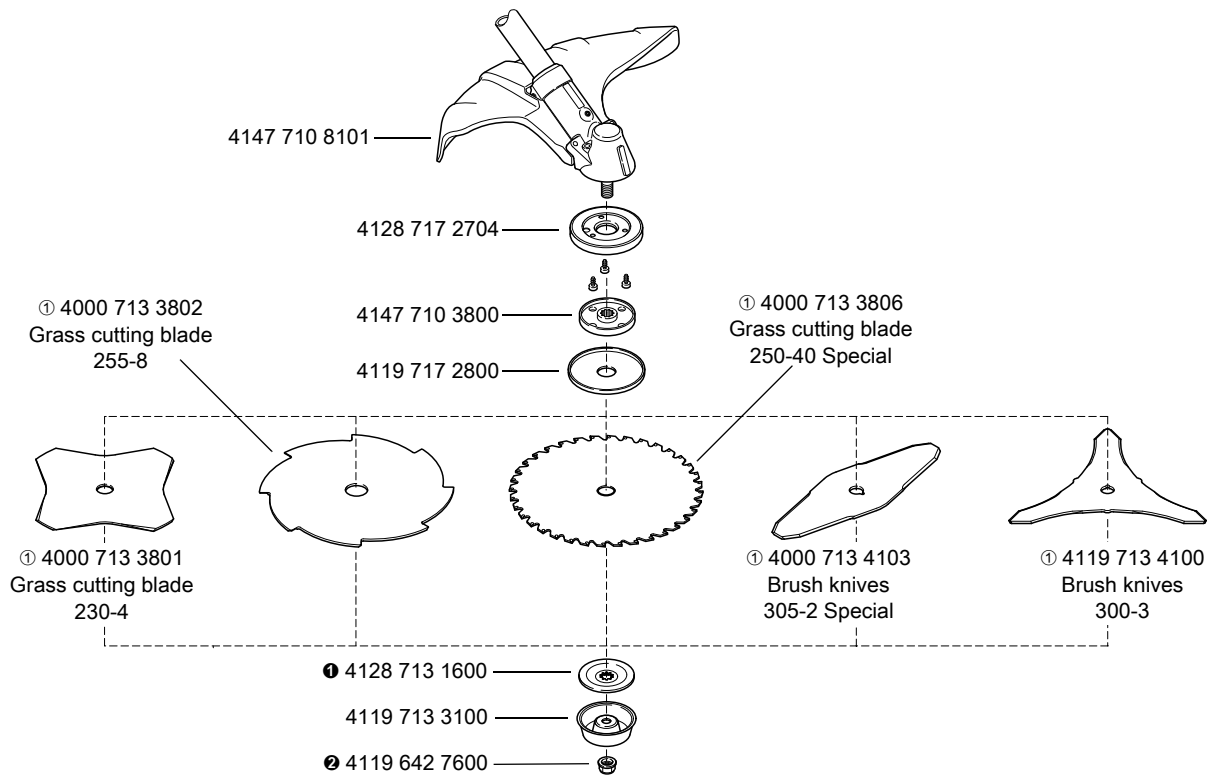

681KT805 KN

① Not approved on brushcutters with loop handle

① + ② = 4147 007 1014

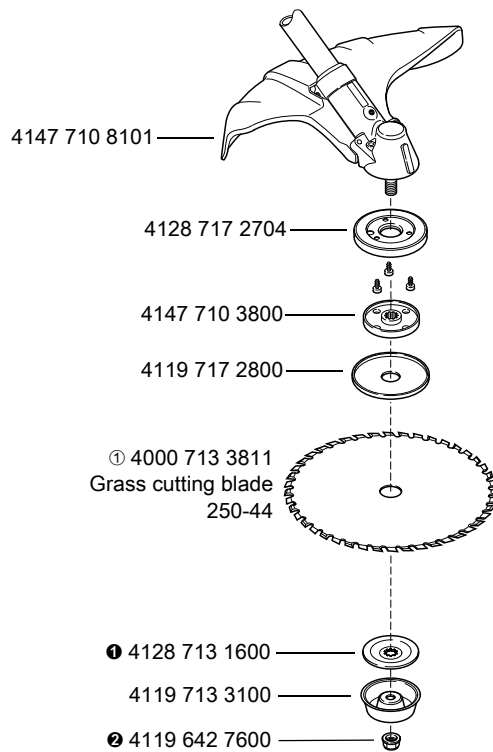

681KT1085 KN

① Not approved on brushcutters with loop handle

① + ② = 4147 007 1014

(a) FS 260 R, 460 R: page 67 (b) from 2010 (c) FS 410 K, 460 K, 490 K: page 91

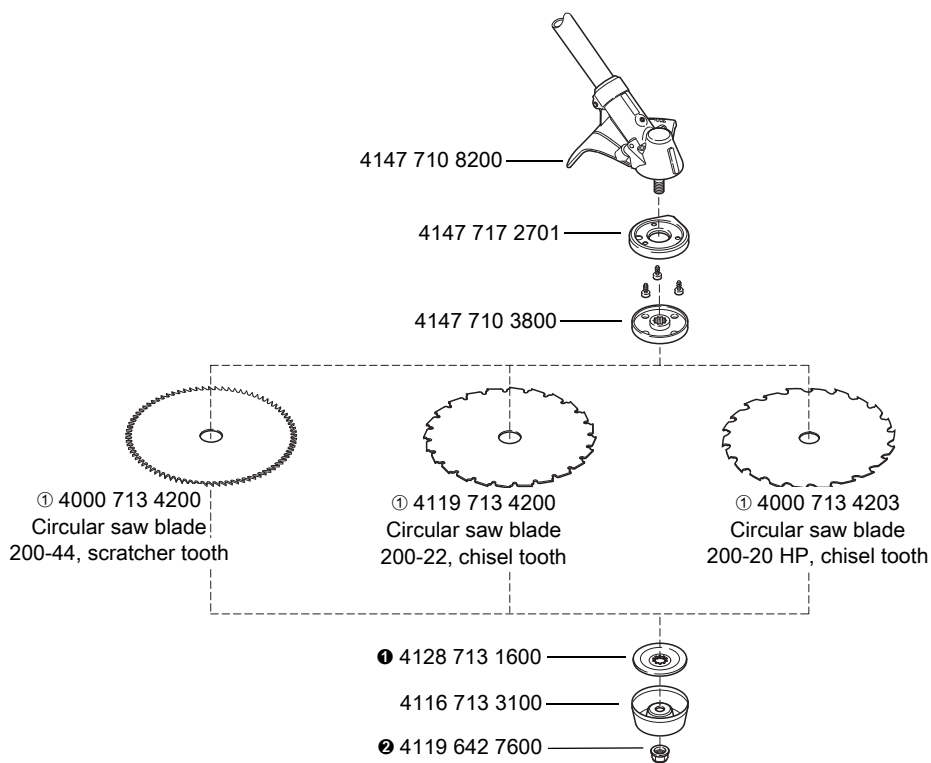

0000-GXX-5711-A0

① Not approved on brushcutters with loop handle

❶ + ❷ = 4147 007 1014

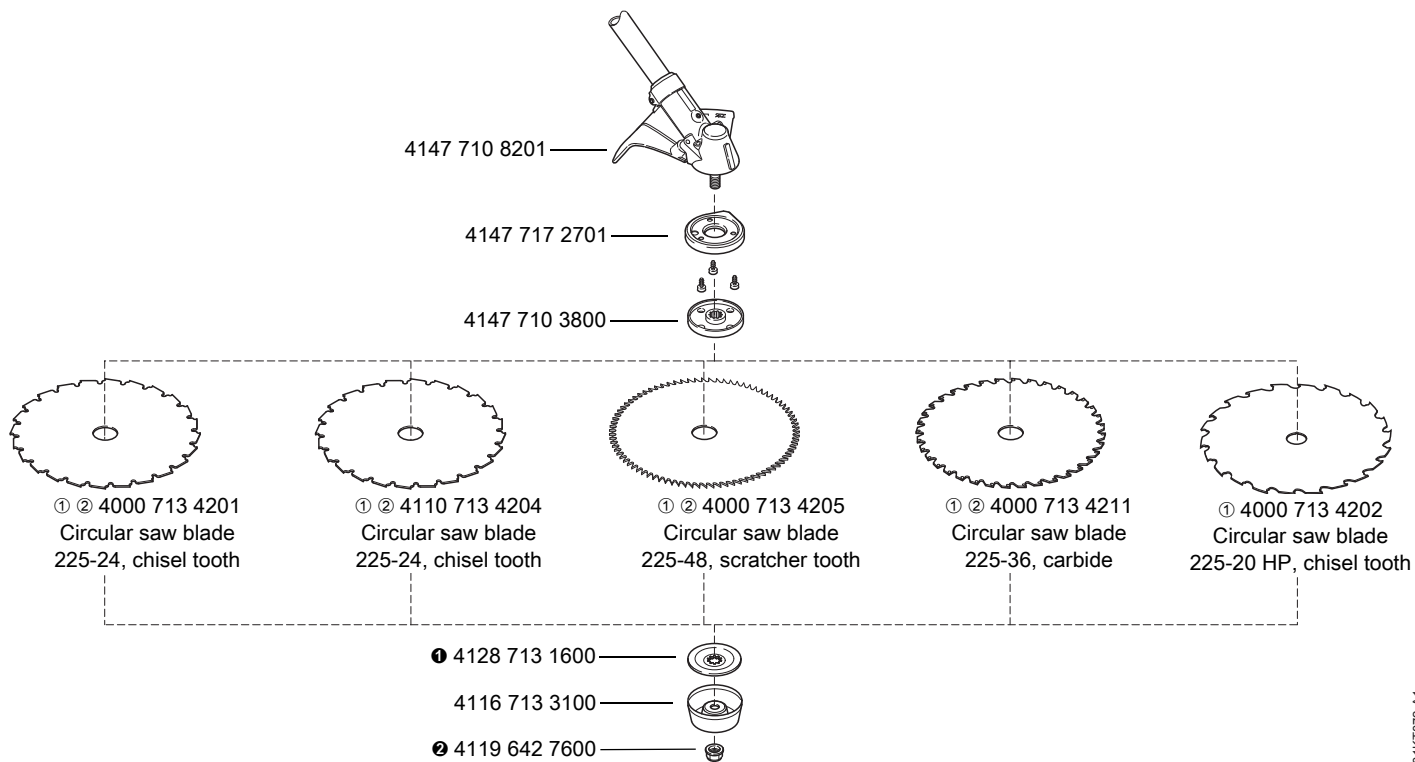

681KT872-A1

① Not approved on brushcutters with loop handle

② Not approved for FS 311

❶ + ❷ = 4147 007 1014

(a) FS 260 R, 460 R: page 67 (b) from 2010 (c) FS 410 K, 460 K, 490 K: page 91

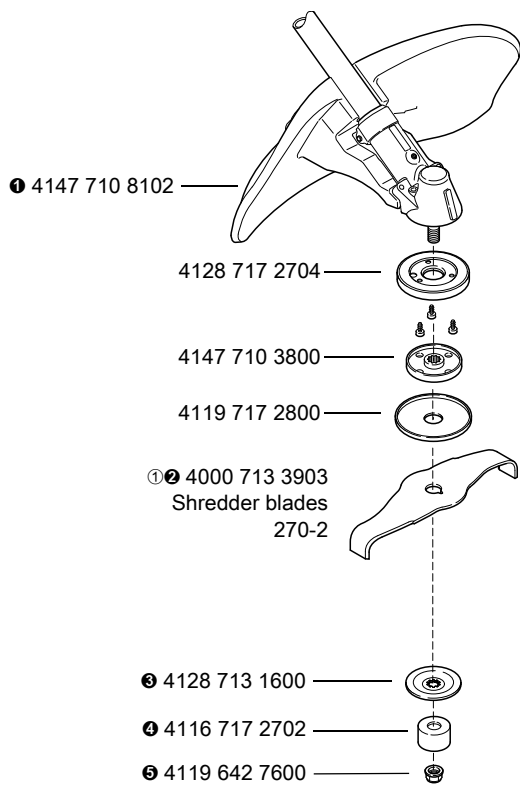

681KTB11 KN

① Not approved on brushcutters with loop handle

① + ② + ④ = 4147 007 1011

③ + ⑤ = 4147 007 1014

(a) up to 1987

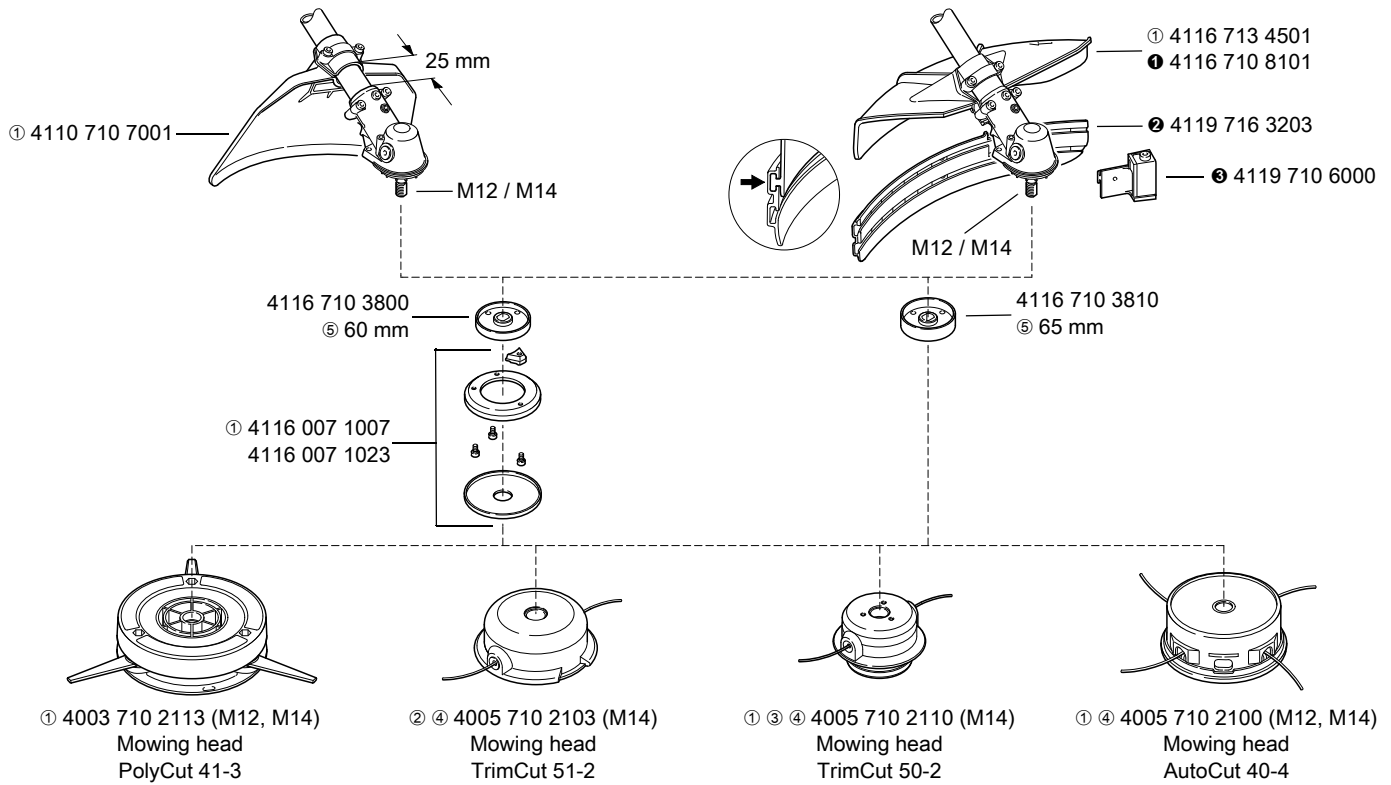

681KT533 KN

① No longer available

② For M12: 4003 710 2104 TrimCut 41-2

③ For M12: 4003 710 2101 TrimCut 40-2

④ Use quiet nylon line in EU

⑤ Diameter

① + ② + ③ = 4116 007 1016

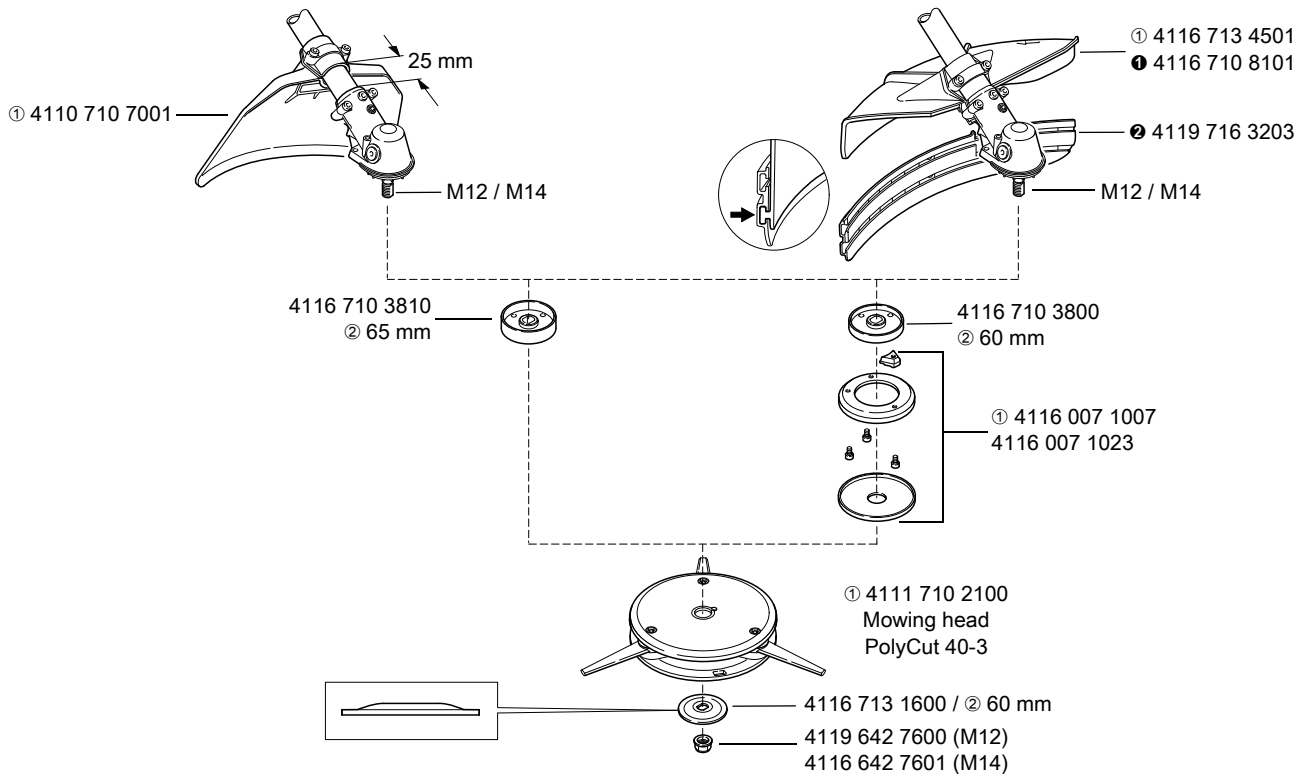

681KT814 KN

① No longer available

② Diameter

① + ② = 4116 007 1016

(a) up to 1987

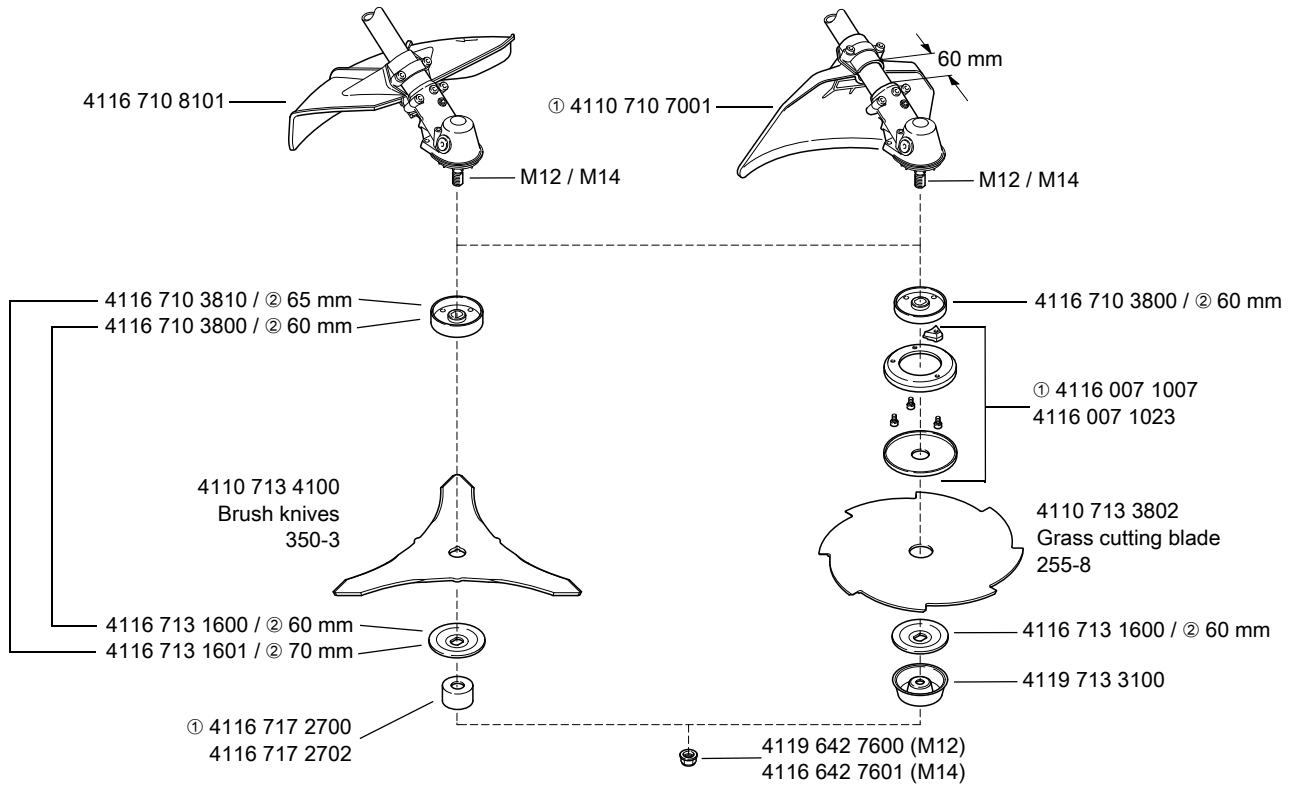

681KT534 KN

① No longer available

② Diameter

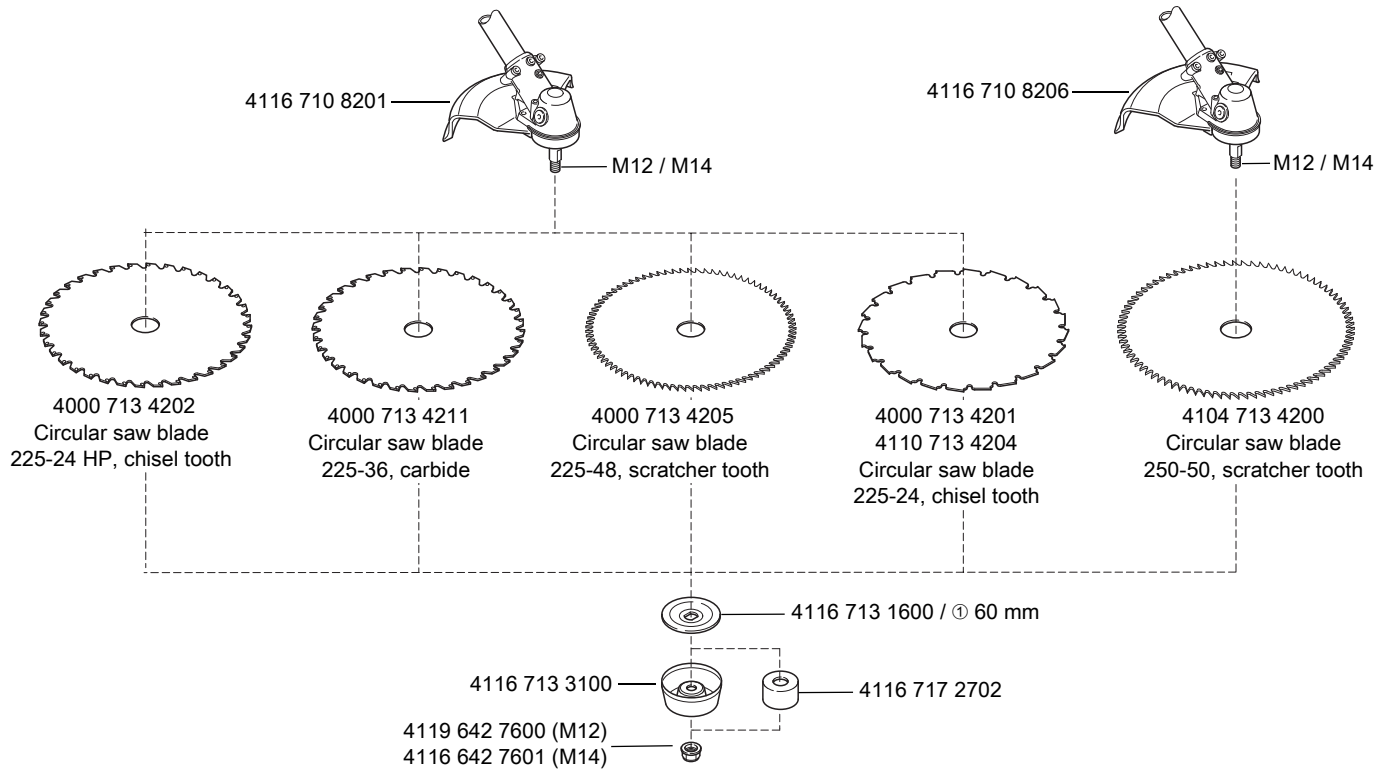

0000-GXX-5712-A0

① Diameter

(a) from 2010 (b) FS 410, 460, 490: page 85 (c) FS 460 R: page 67

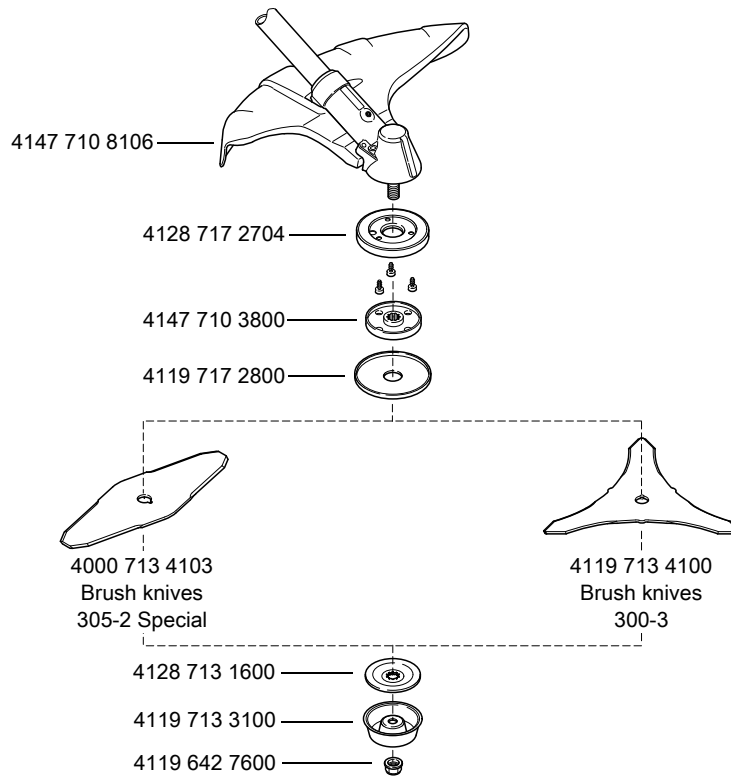

681KT813 KN

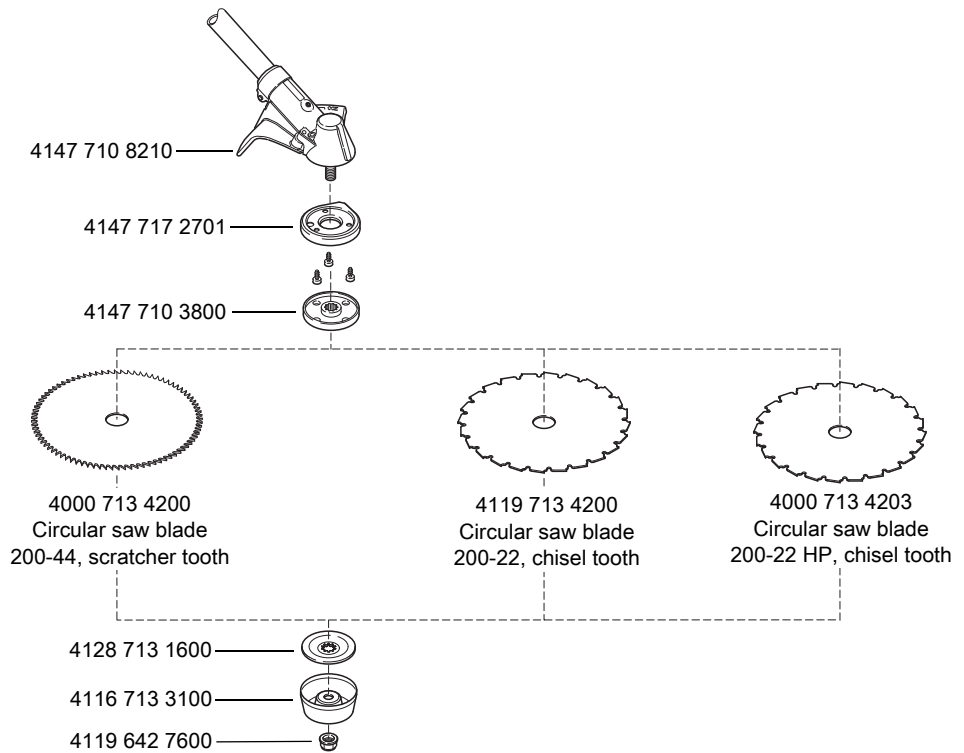

381KT513-A1

(a) from 2010 (b) FS 410, 460, 490: page 85 (c) FS 460 R: page 67

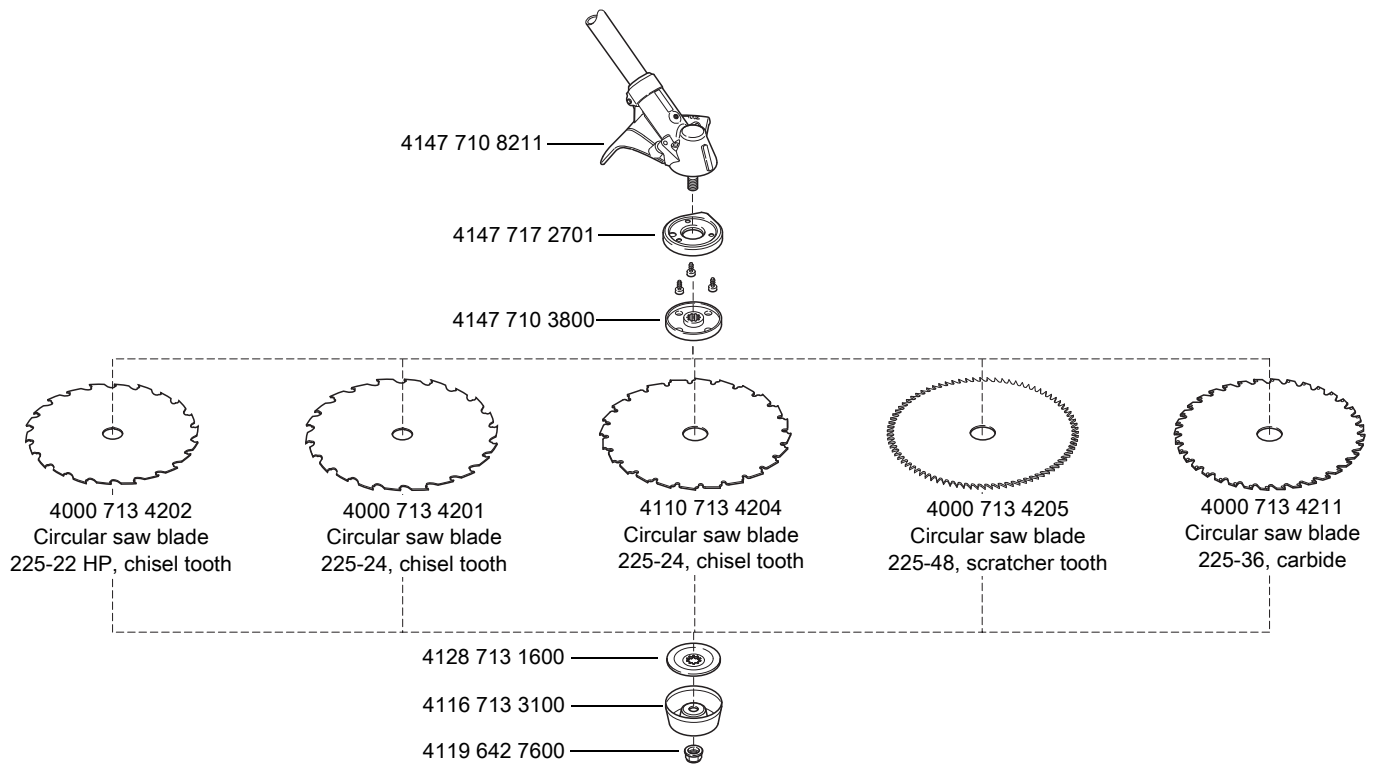

0000-GXX-5713-A0

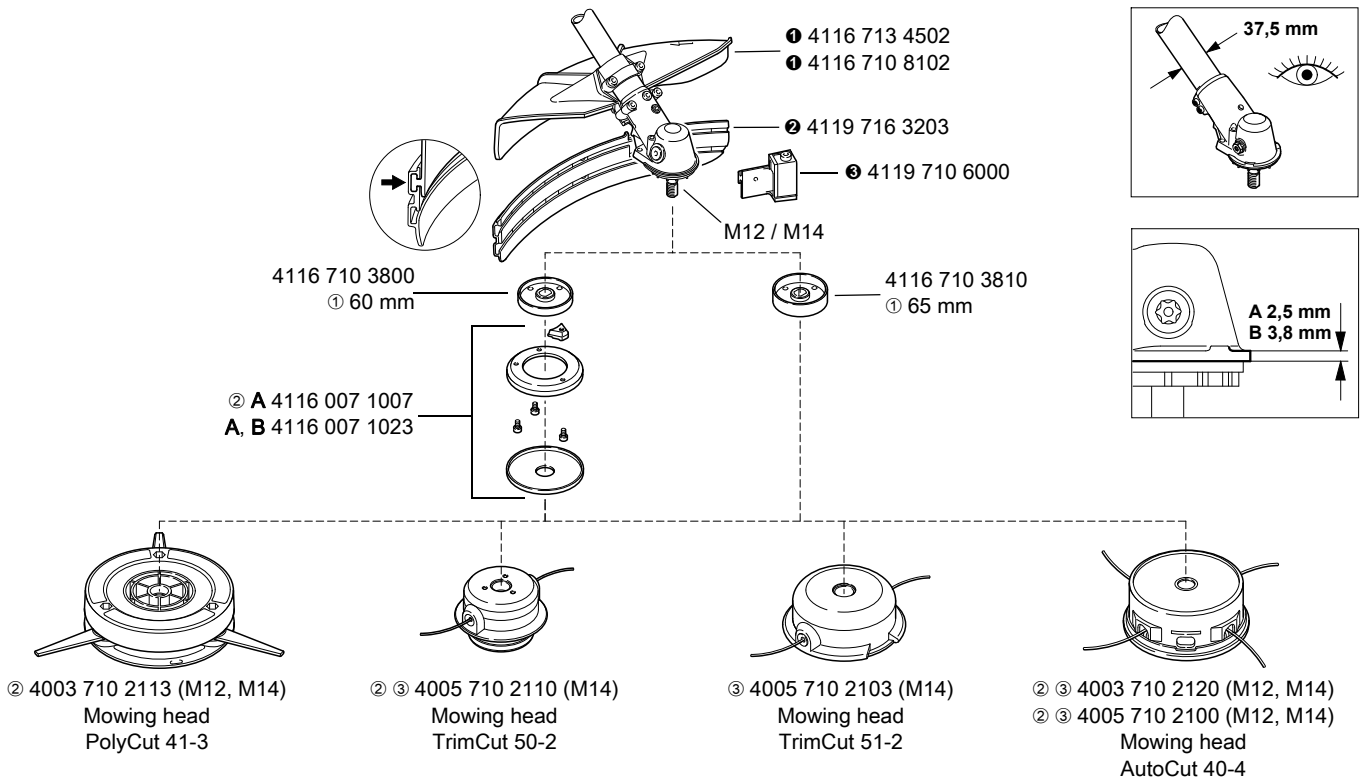

681KT566 KN

- ① Diameter
- ② No longer available
- ③ Use quiet nylon line in EU
- ① + ② + ③ = 4116 007 1020

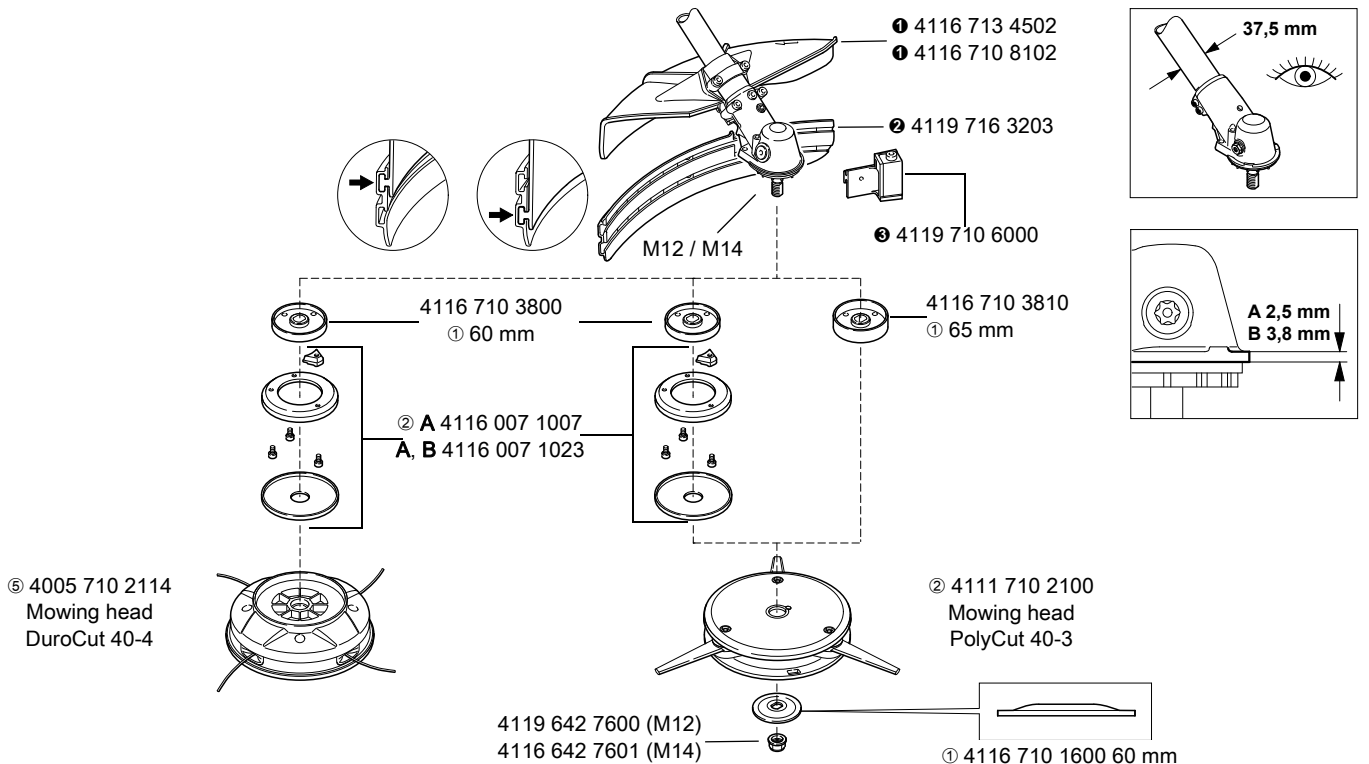

681KT816 KN

- ① Diameter
- ② No longer available
- ③ For DuroCut 40-4
- ④ For PolyCut 40-3
- ⑤ Use quiet nylon line in EU
- ① + ② + ③ = 4116 007 1020

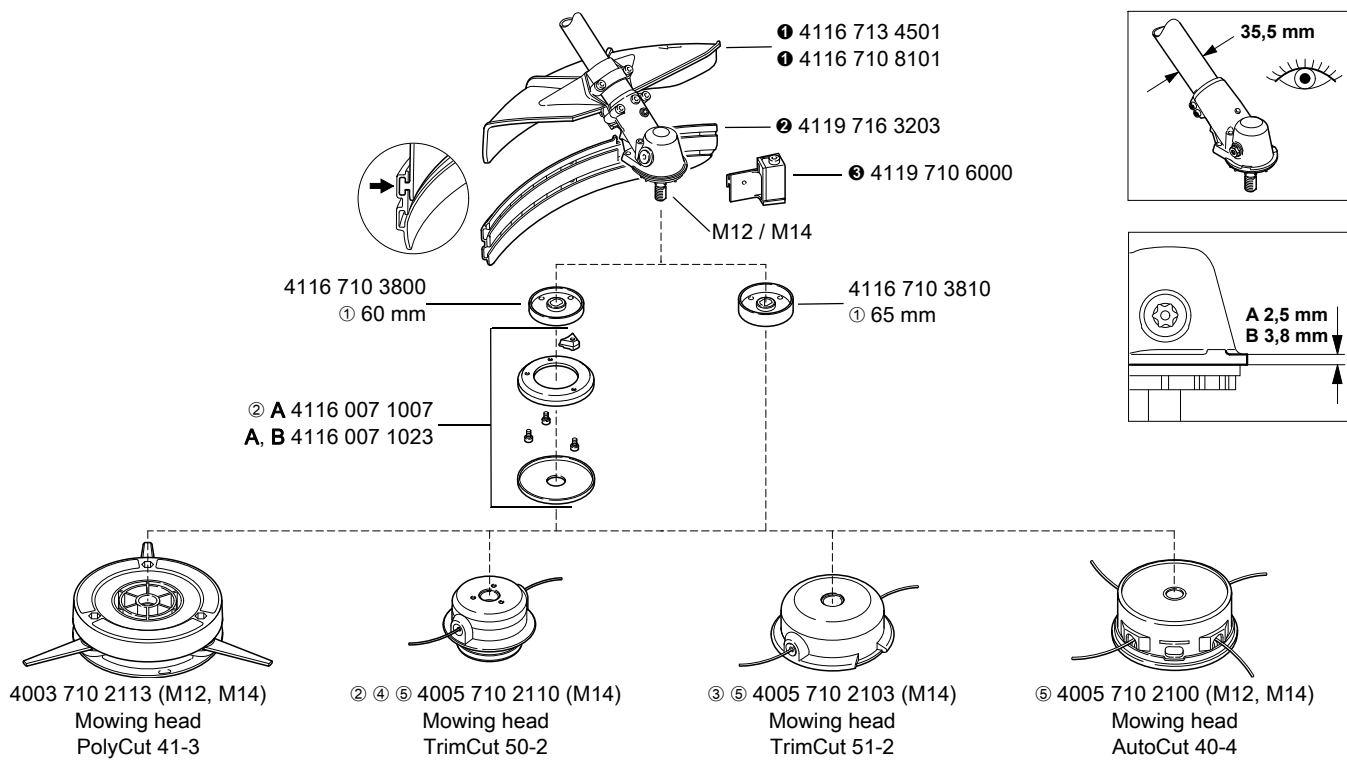

681KT817 KN

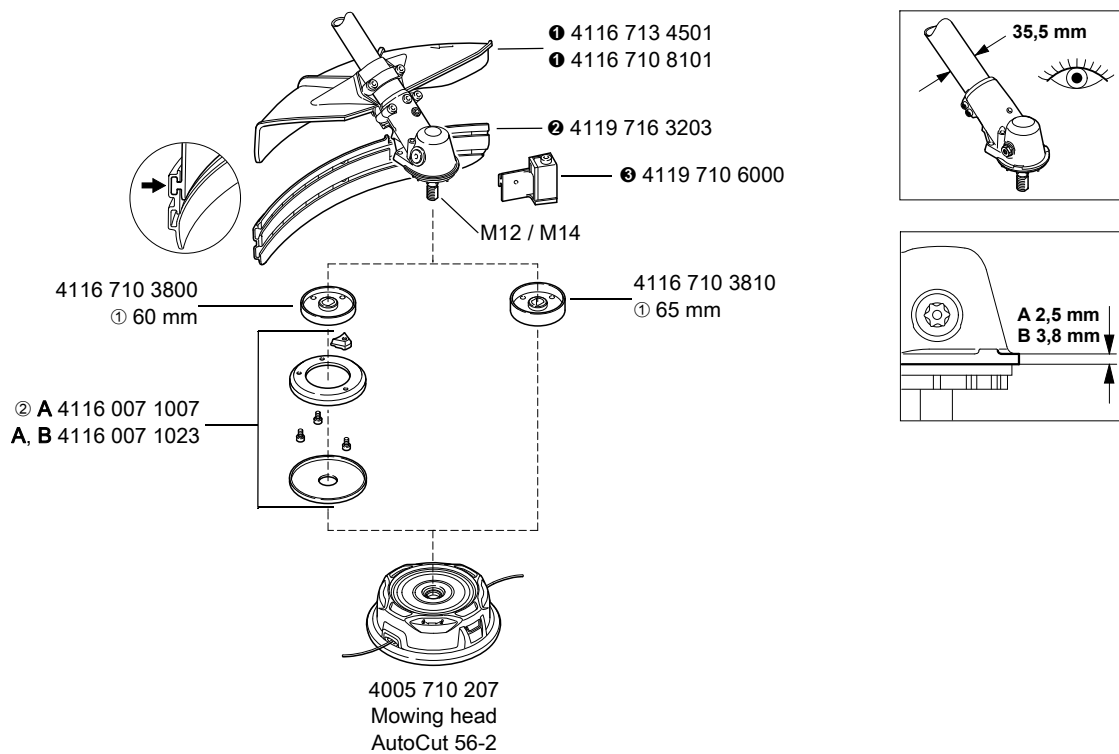

681KT1122 KN

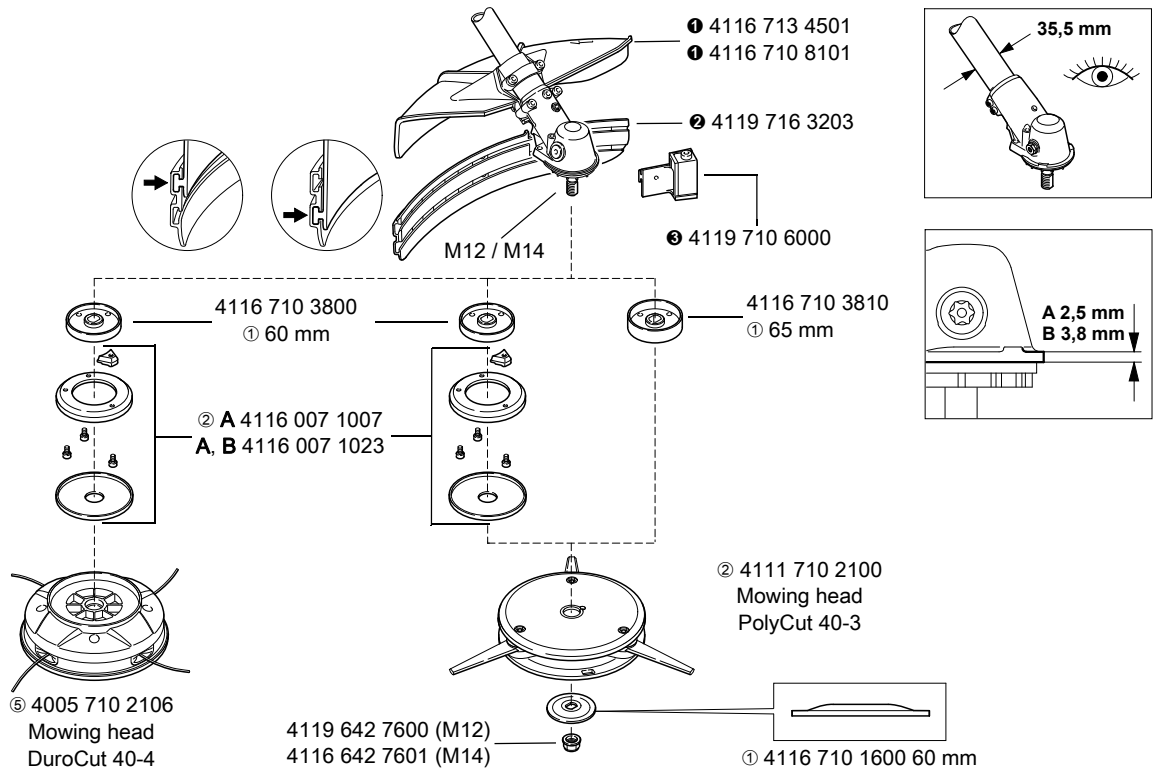

681KT818 KN

- ① Diameter
- ② No longer available
- ③ For DuroCut 40-4
- ④ For PolyCut 40-3
- ⑤ Use quiet nylon line in EU
- ① + ② + ③ = 4116 710 1016

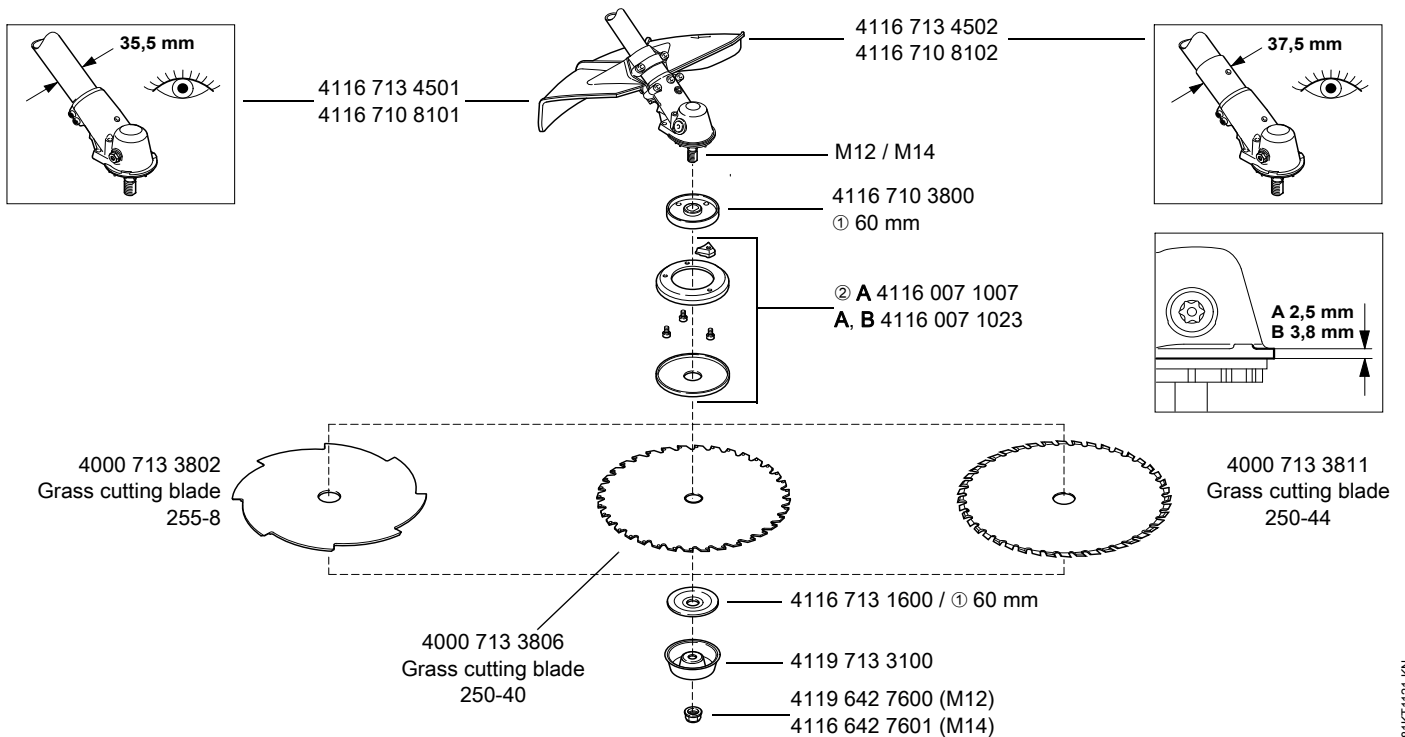

681KT1121 KN

- ① Diameter
- ② No longer available

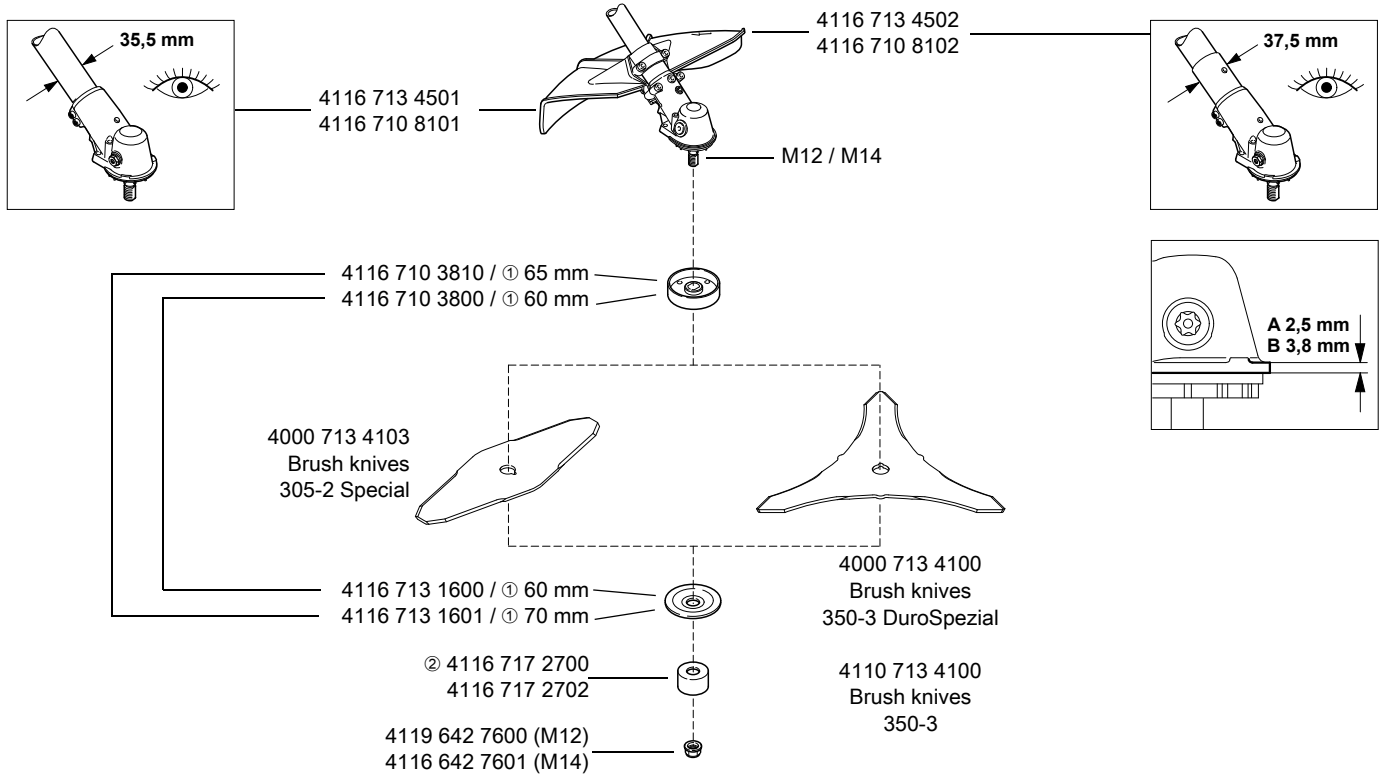

681KT579 KN

① Diameter

② No longer available

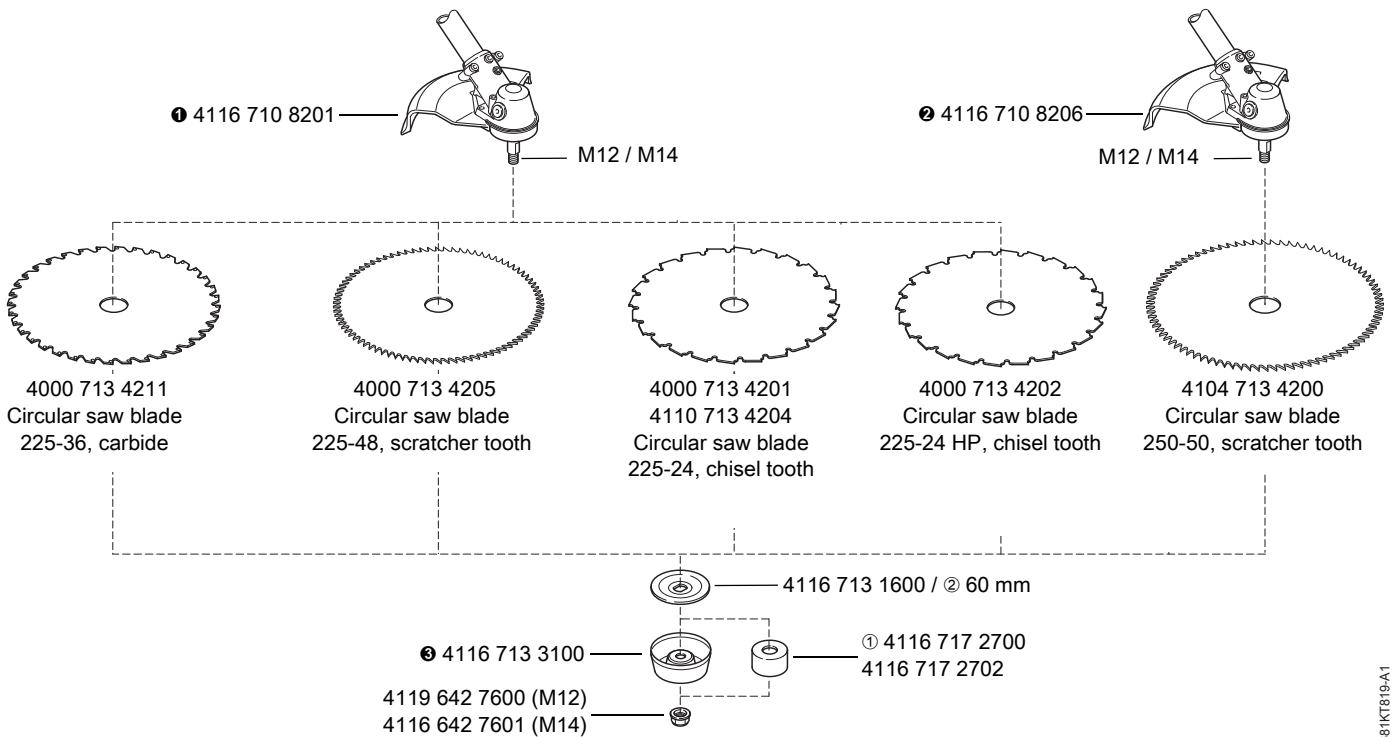

681KT819-A1

① No longer available

② Diameter

① + ③ + Transport guard = 4116 007 1019

② + ③ + Transport guard = 4116 007 1018

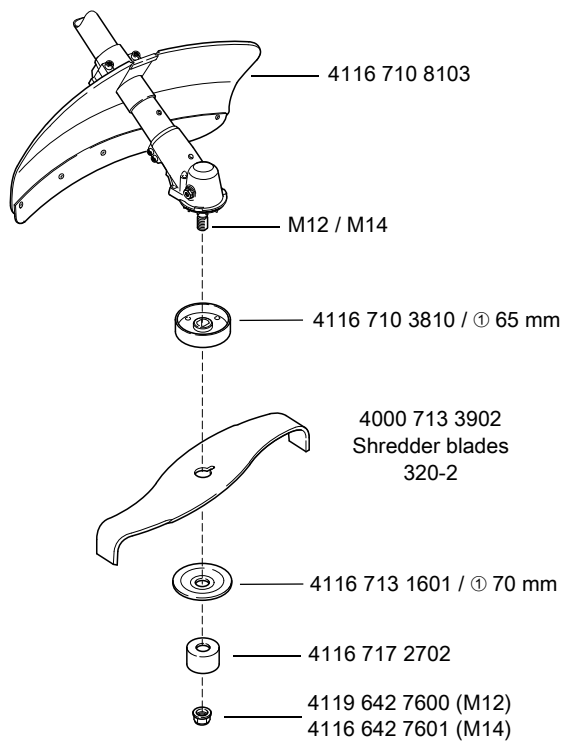

681KT560 KN

⌀ Diameter

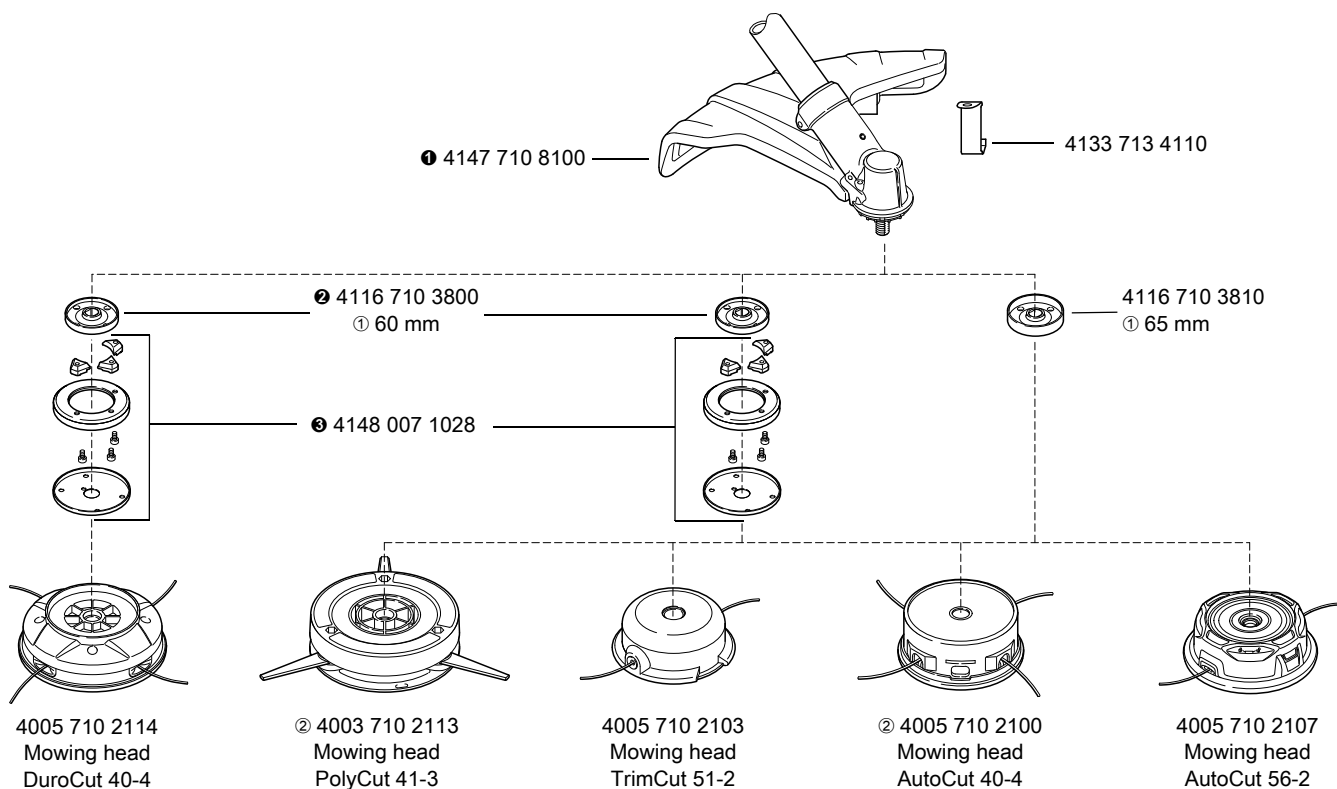

681KT1086 KN

① Diameter

② No longer available

❶ + ❷ + ❸ = 4148 007 1027

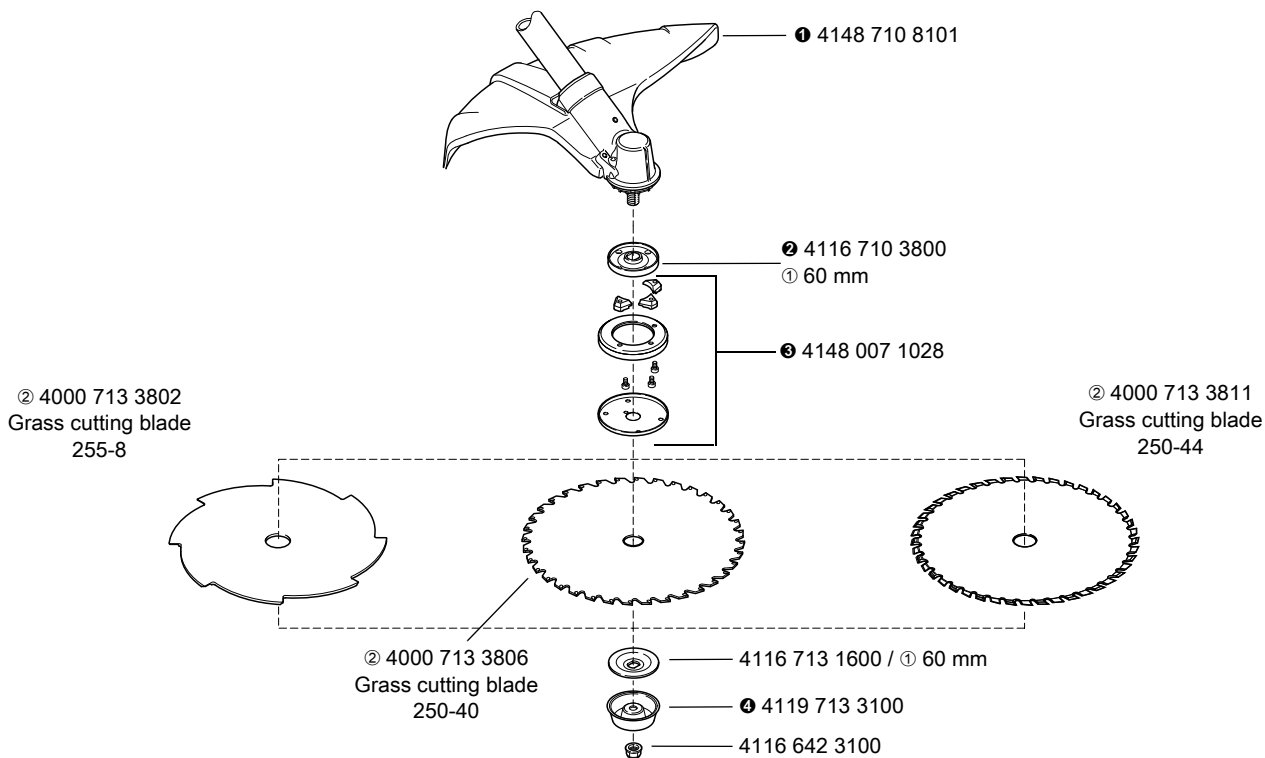

681KT1103 KN

① Diameter

② Not approved on brushcutters with loop handle

❶ + ❷ + ❸ + ❹ = 4148 007 1024

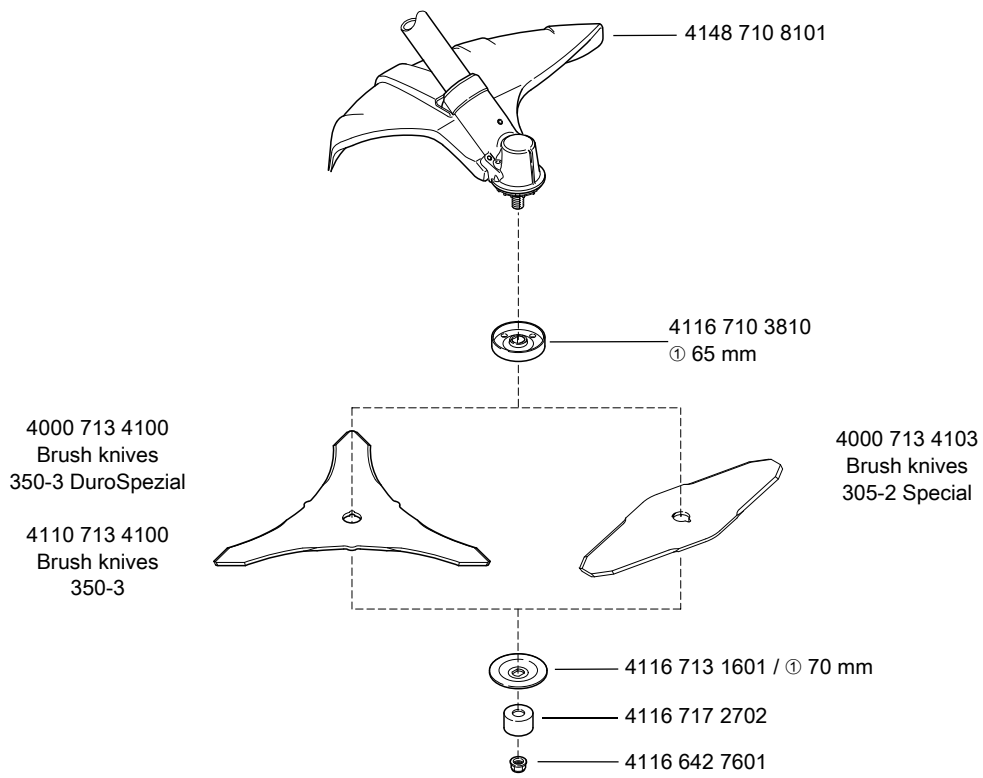

681KT906 KN

① Diameter

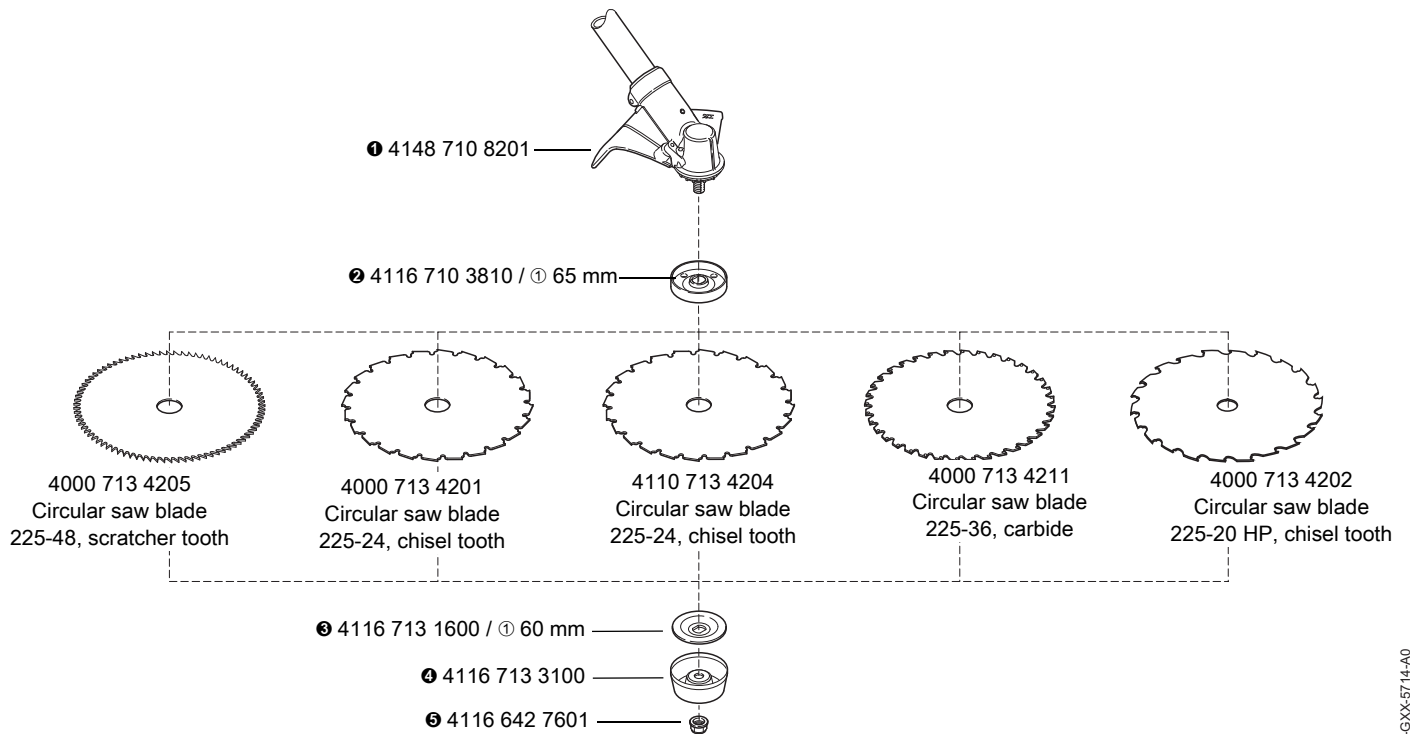

0000-GXX-5714-A0

① Diameter

① + ② + ③ + ④ + ⑤ + Transport guard = 4148 007 1022

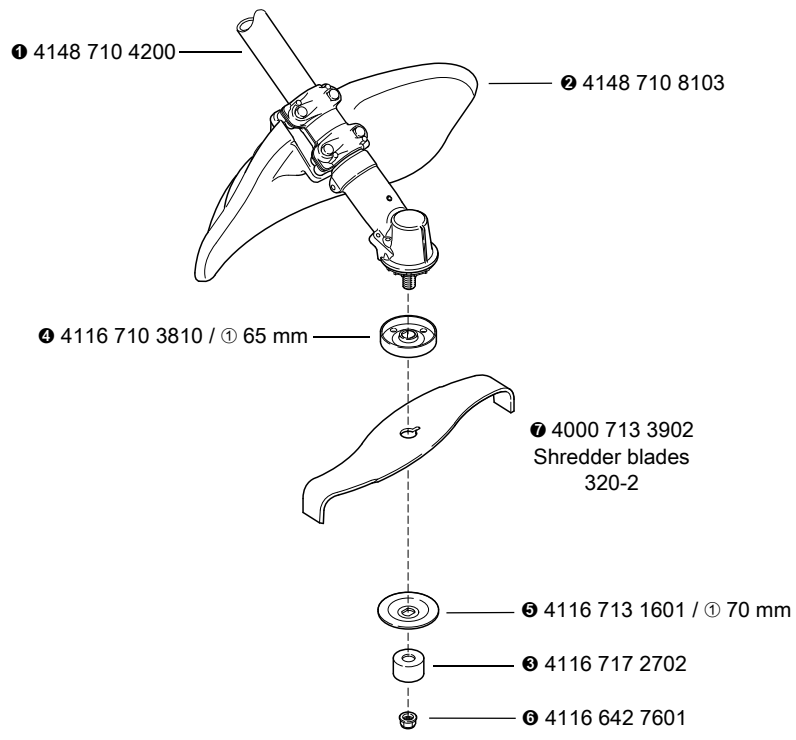

681KT663 KN

$\text{\textcircled{1}}$ Diameter

4 + 5 + 6 = 4148 007 1009

1 + 2 + 3 + 7 = 4148 007 1012

1 + 2 + 3 = 4148 007 1021

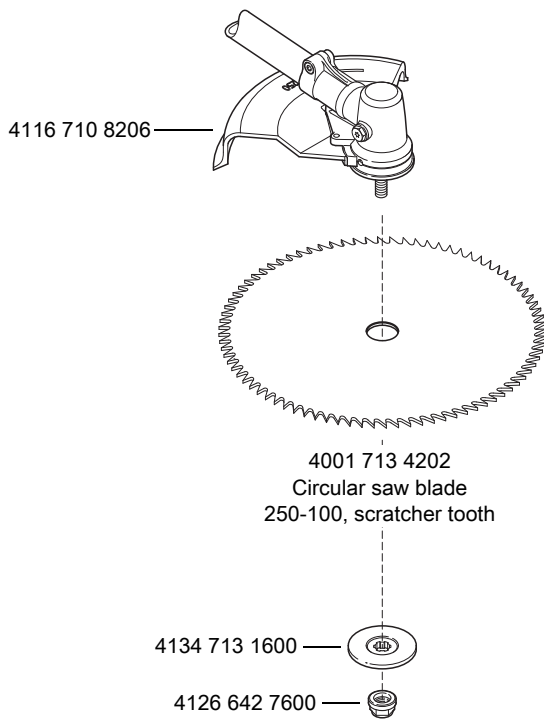

0000-GXX-8291-A0

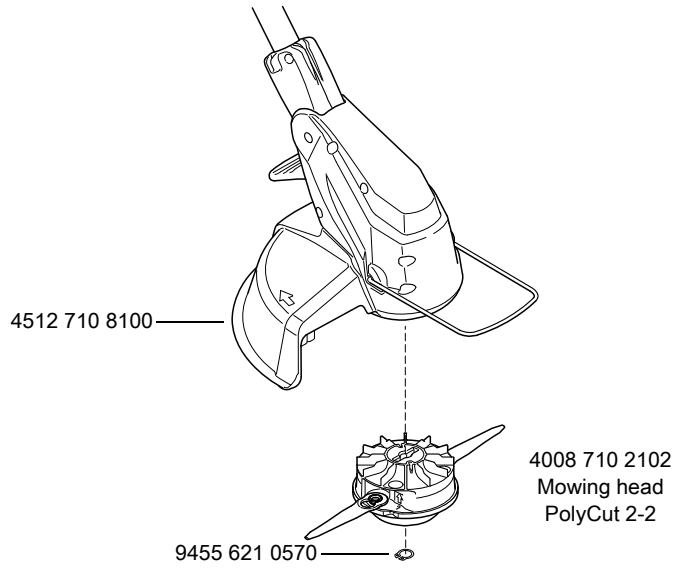

0000-GXX-361 9-A0

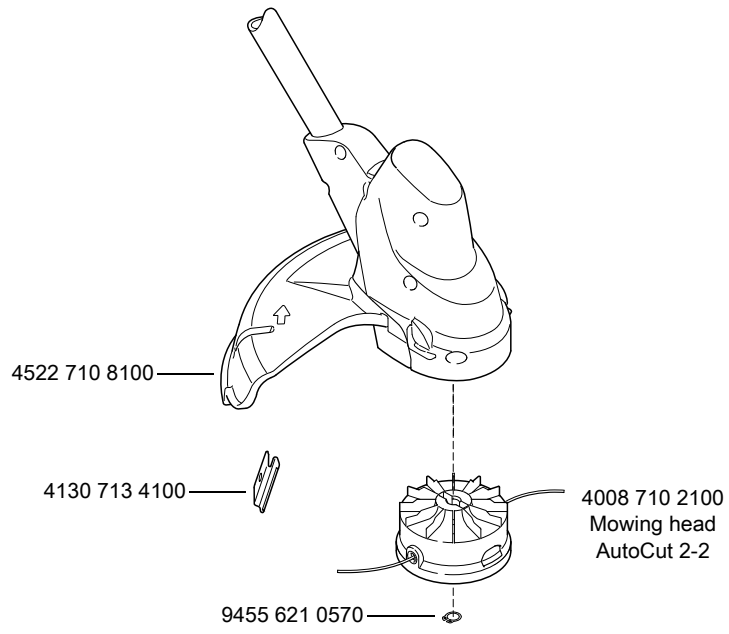

0000-GXX-3820-A0

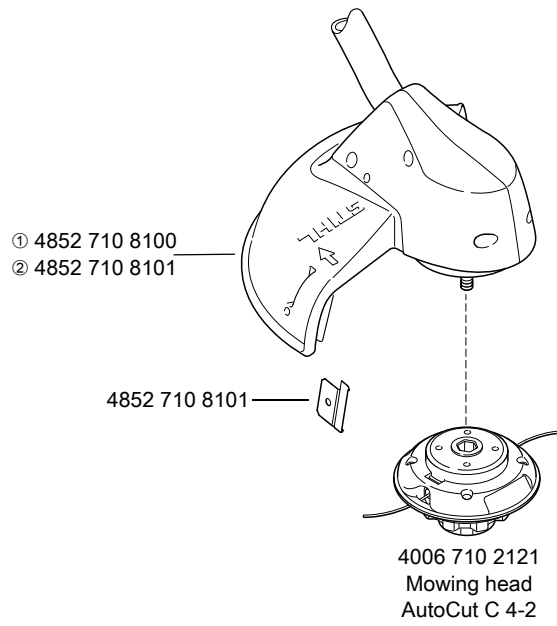

681KT806 KN

① FSA 65

② FSA 85

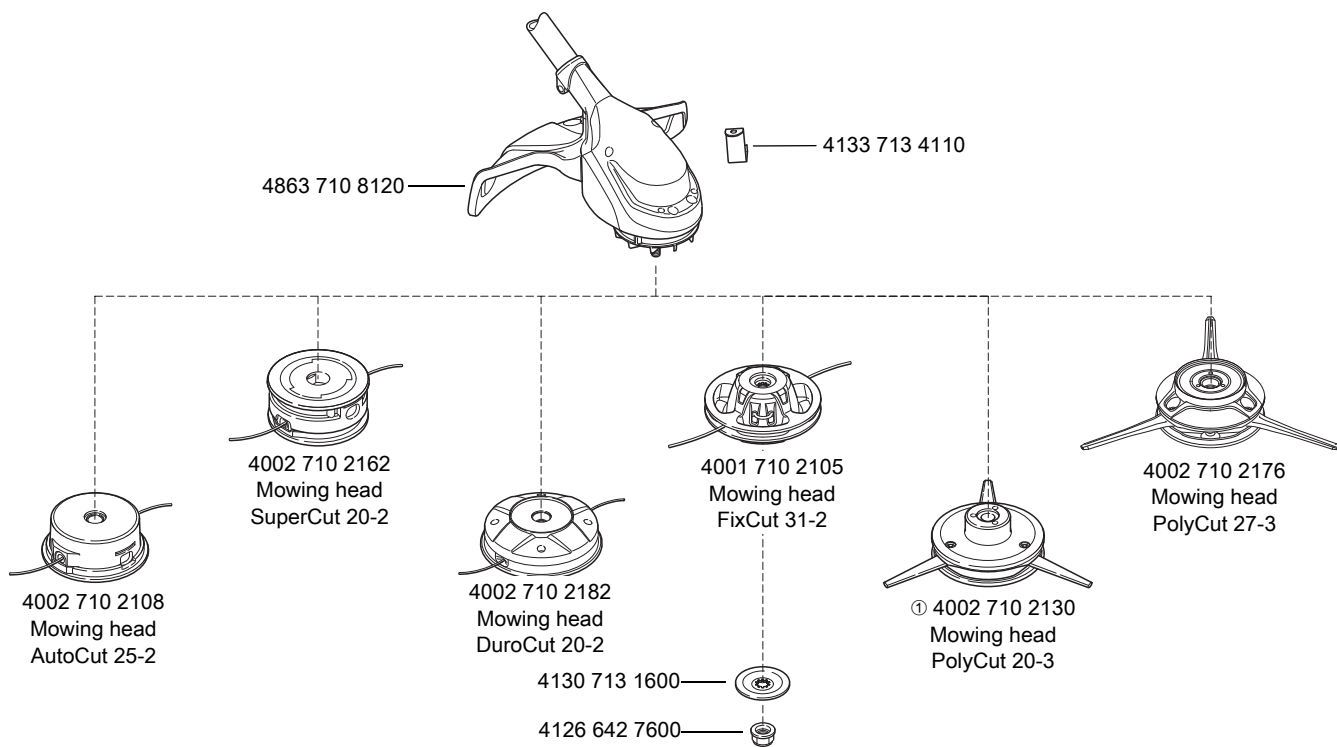

0000-GXX-5715-A0

① No longer available

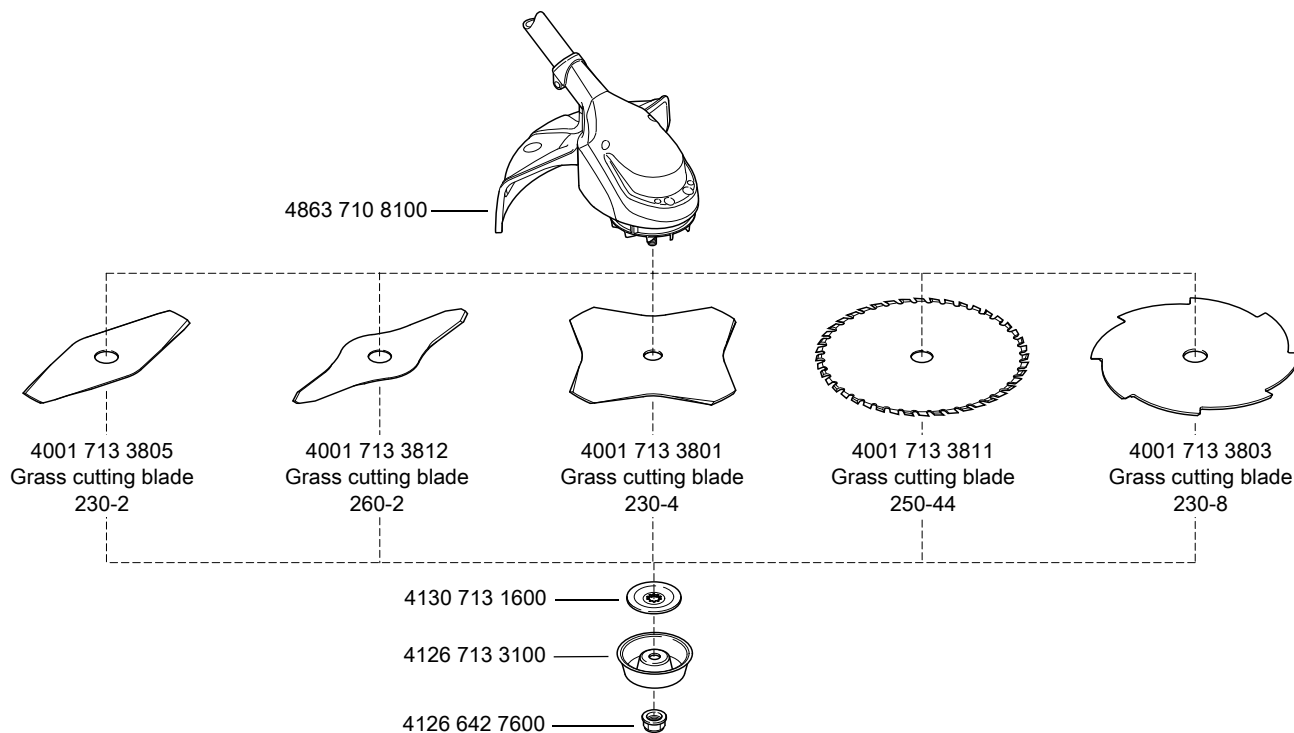

681KT1088 KN

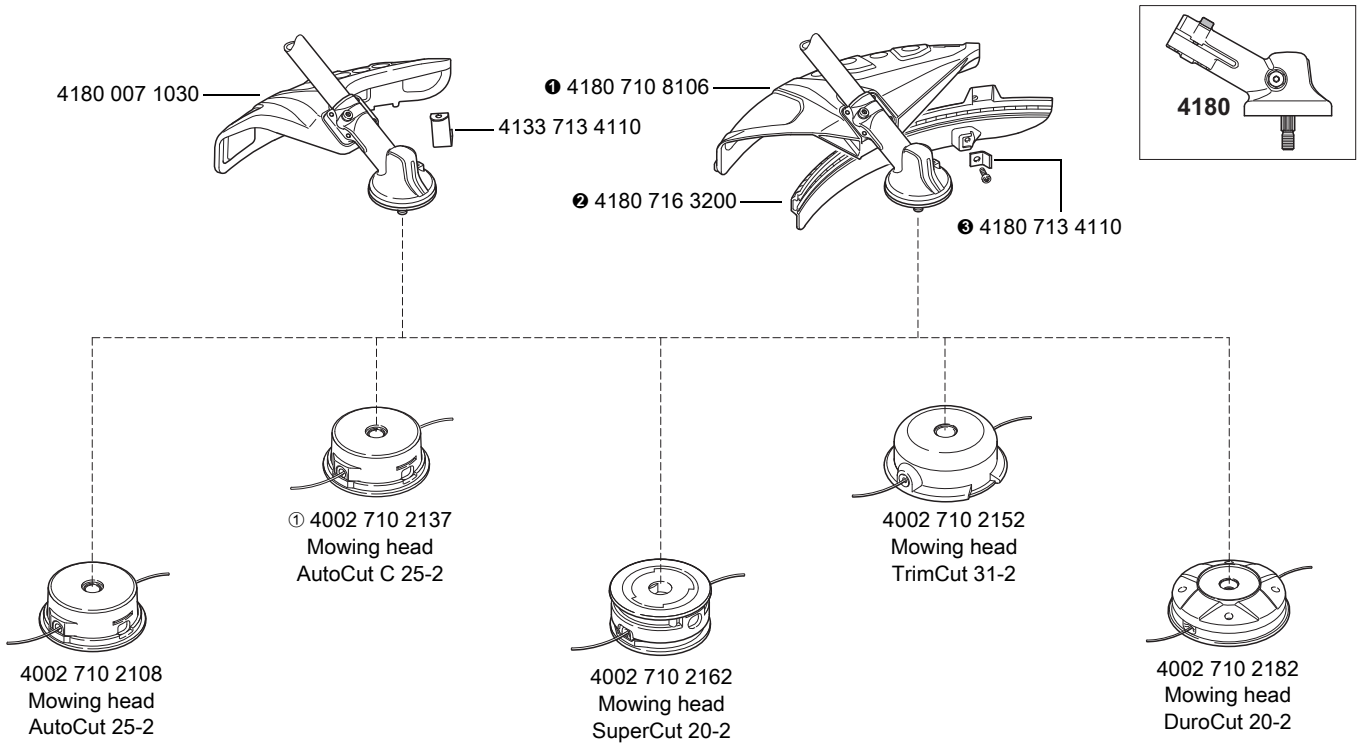

0000-GXX-5716-A0

① No longer available

① + ② + ③ = 4180 007 1028



0000-GXX-5717-A0

① No longer available

① + ② + ③ = 4180 007 1028

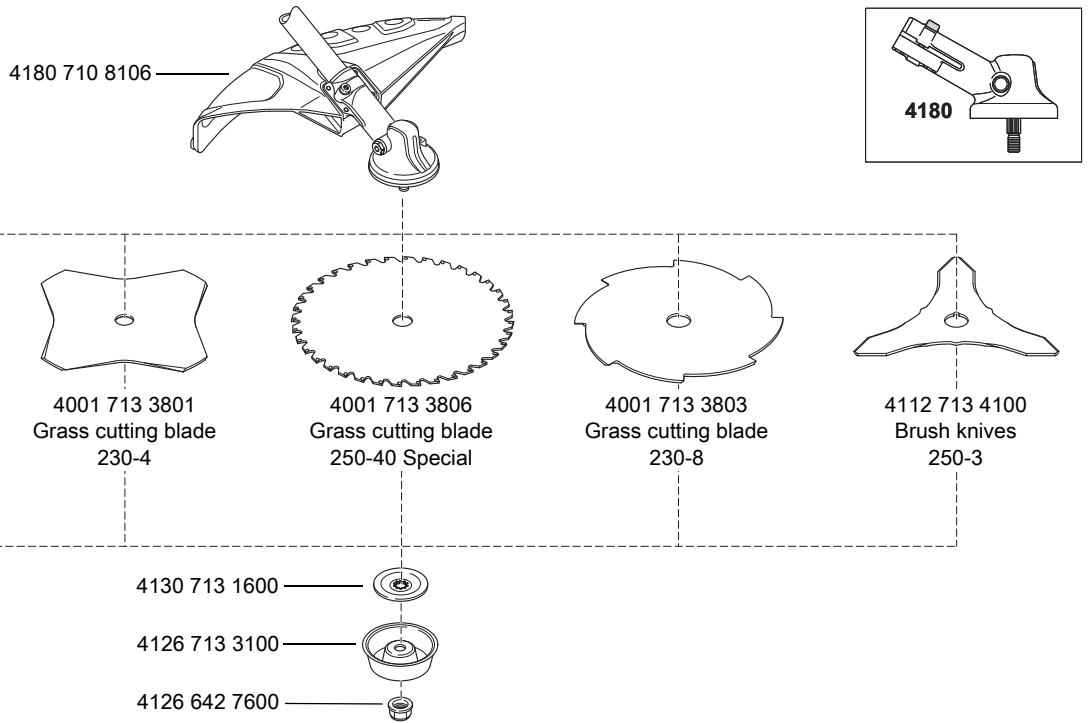

0000-GXX-3464-A0

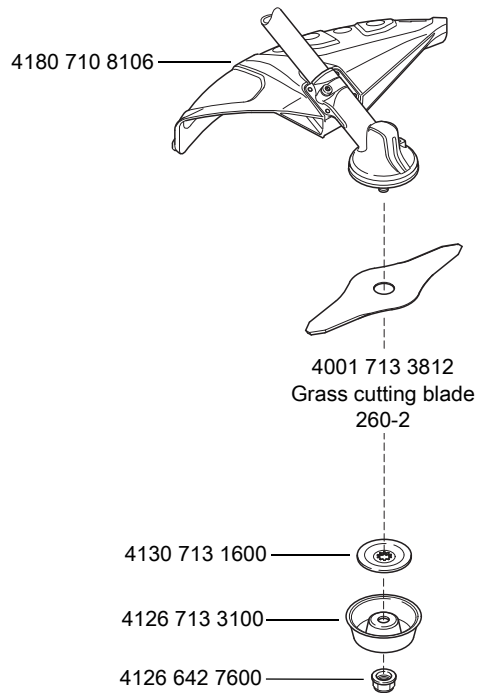

0000-GXX-5719-A0

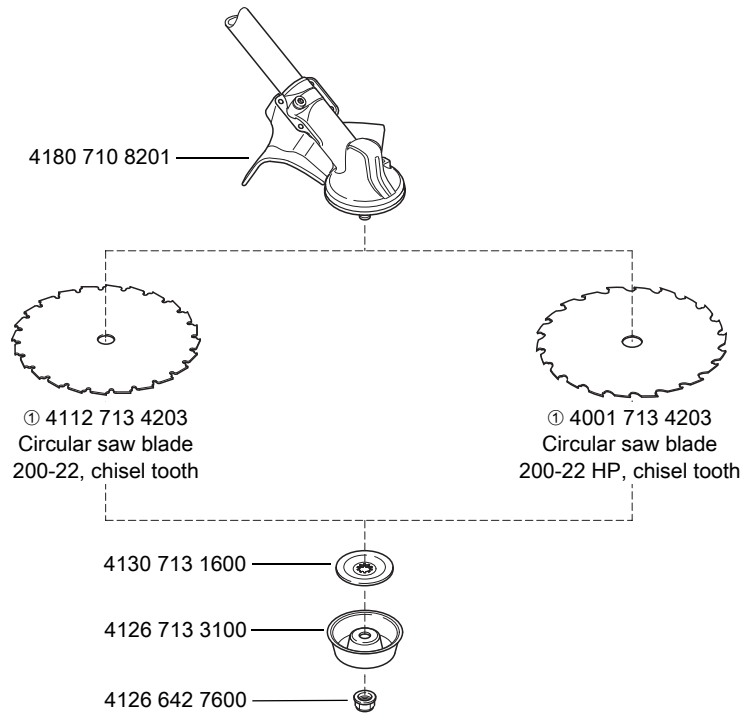

0000-GXX-5720-A0

① Not approved on brushcutters with loop handle

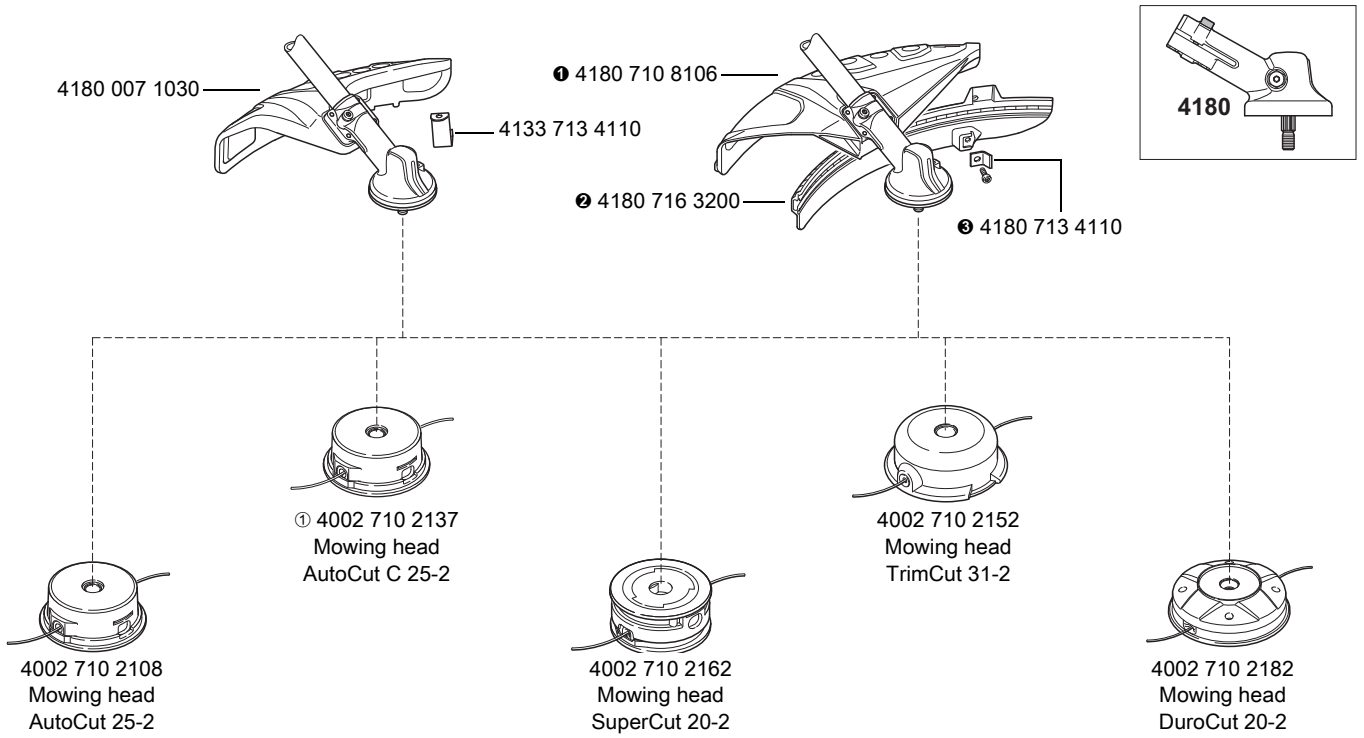

0000-GXX-5716-A0

① No longer available

① + ② + ③ = 4180 007 1028

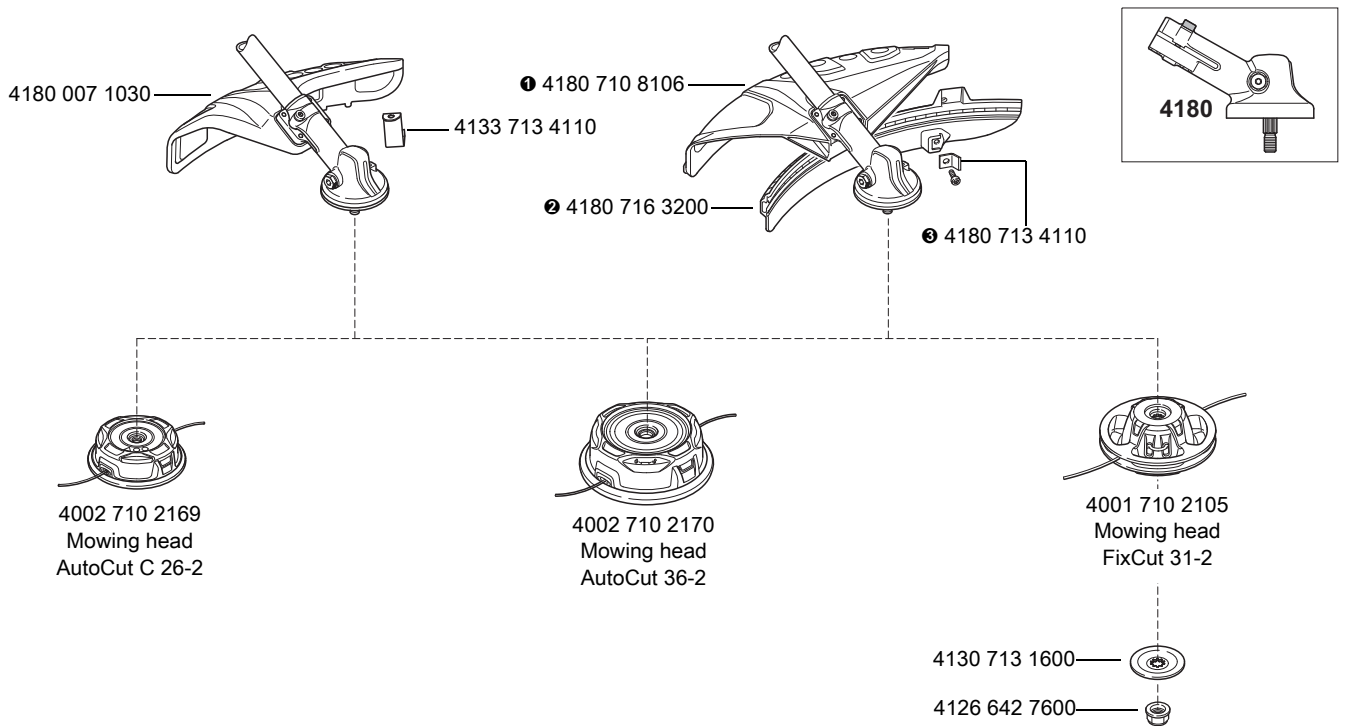

0000-GXX-5717-A0

① + ② + ③ = 4180 007 1028

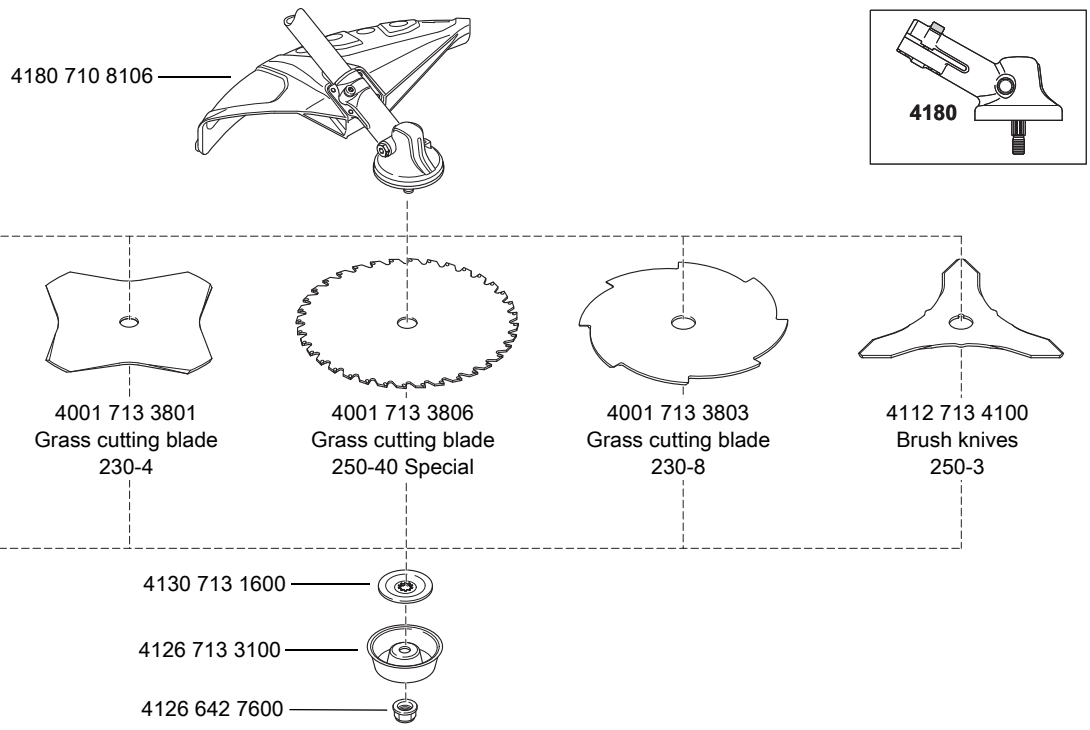

0000-GXX-3464-A0

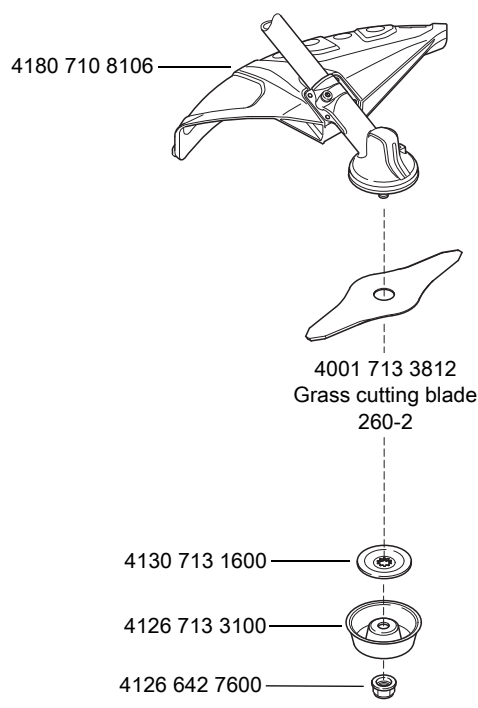

0000-GXX-5719-A0

(a) from 2015

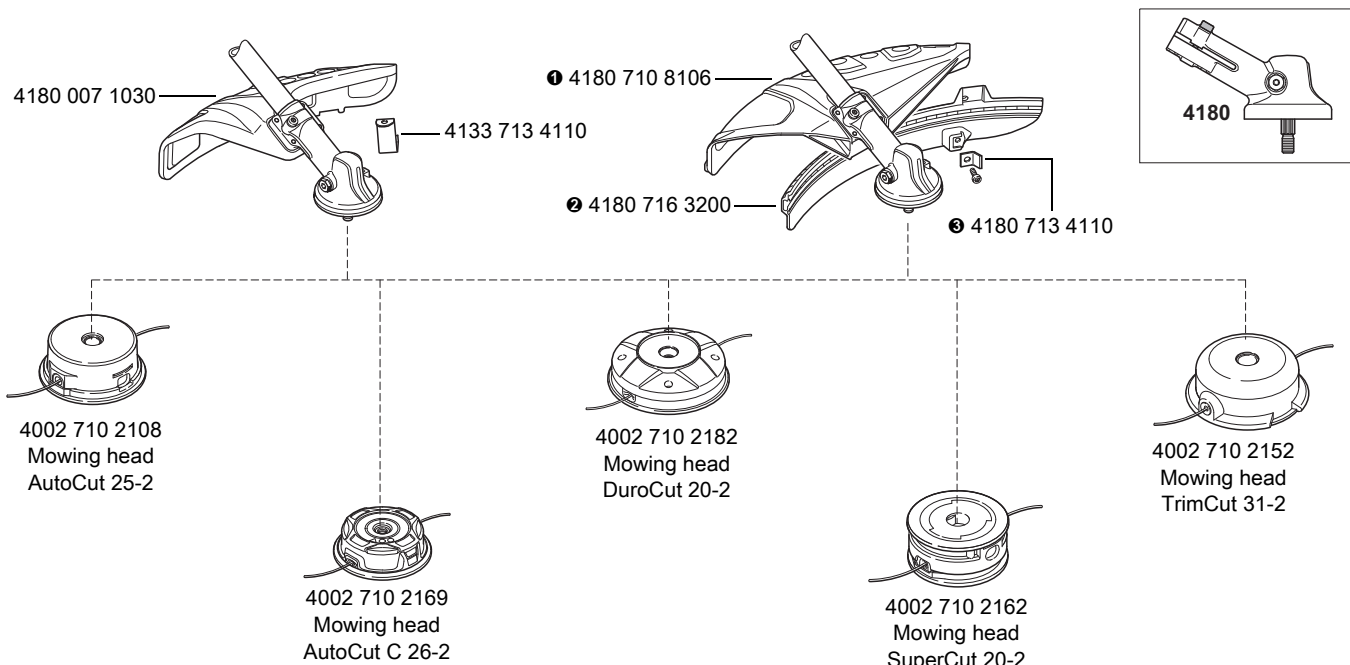

0000-GXX-8227-A0

1 + 2 + 3 = 4180 007 1028

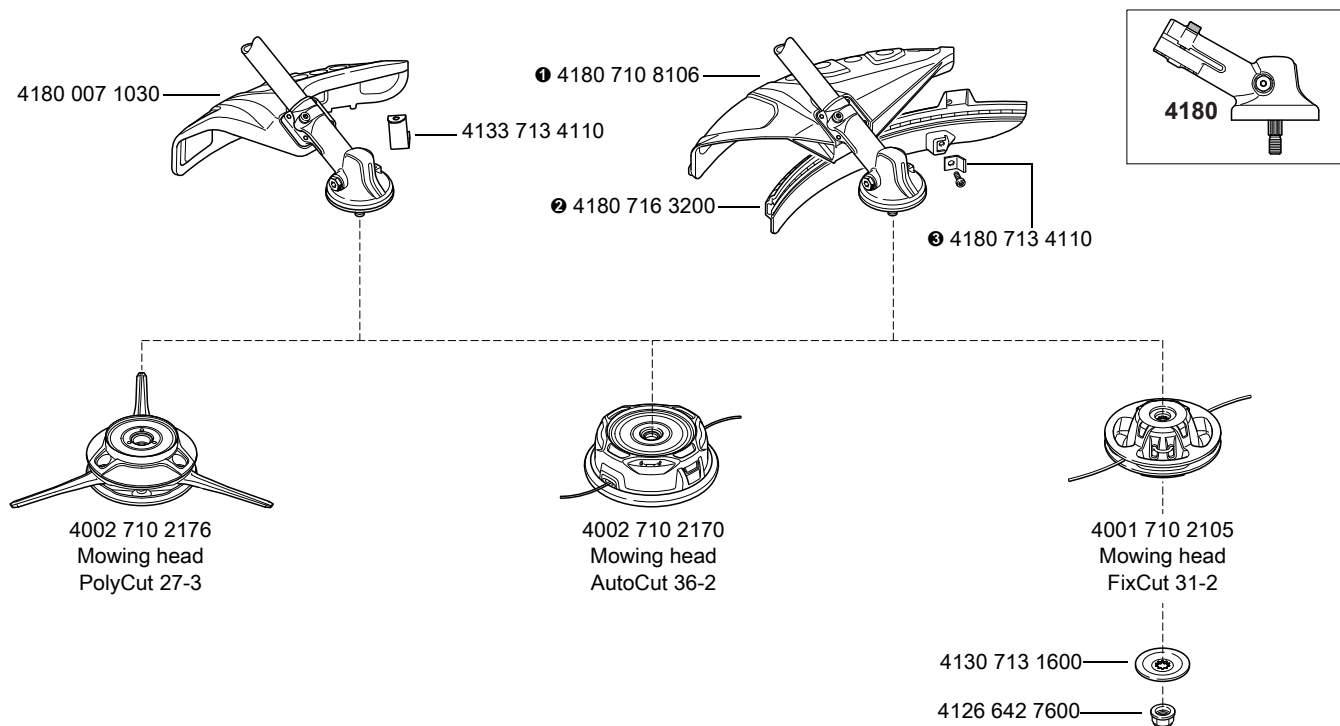

0000-GXX-9171-A0

1 + 2 + 3 = 4180 007 1028

(a) from 2015

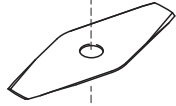
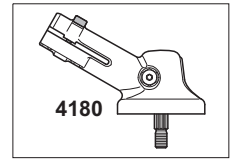
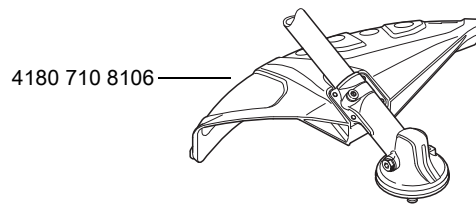

4001 713 3805
Grass cutting blade
230-2

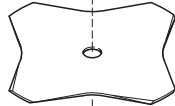

4001 713 3801
Grass cutting blade
230-4



4001 713 3803
Grass cutting blade
230-8

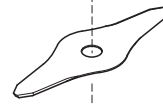

4001 713 3812
Grass cutting blade
260-2

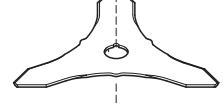

4112 713 4100
Brush knives
250-3

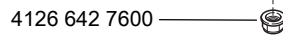
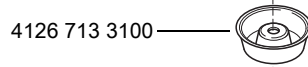
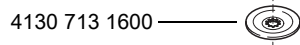

0000-GXX-6229-A0

FSE 31

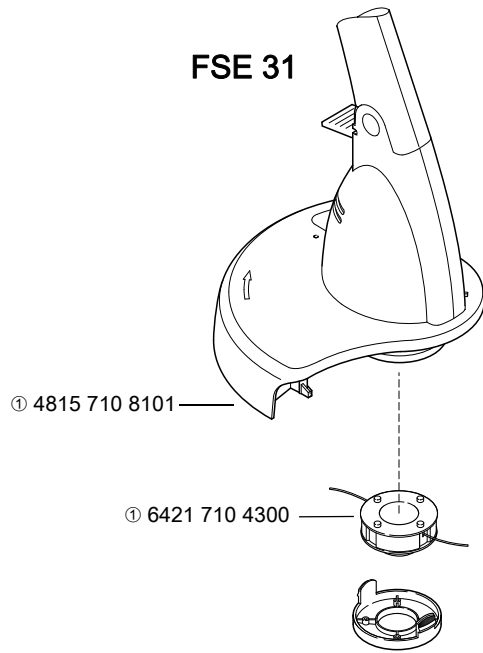

FSE 41

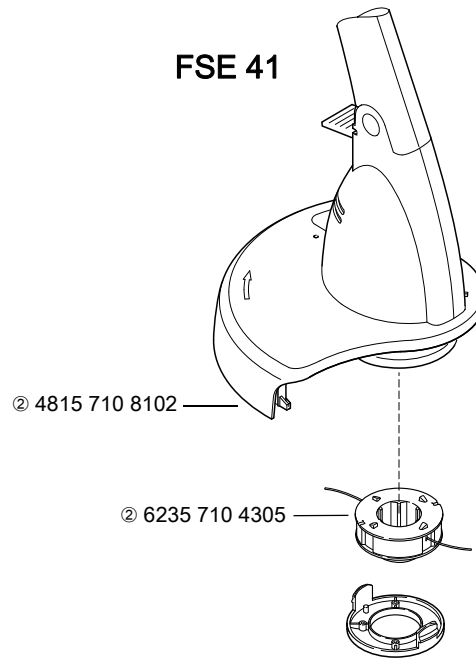

① FSE 31

② FSE 41

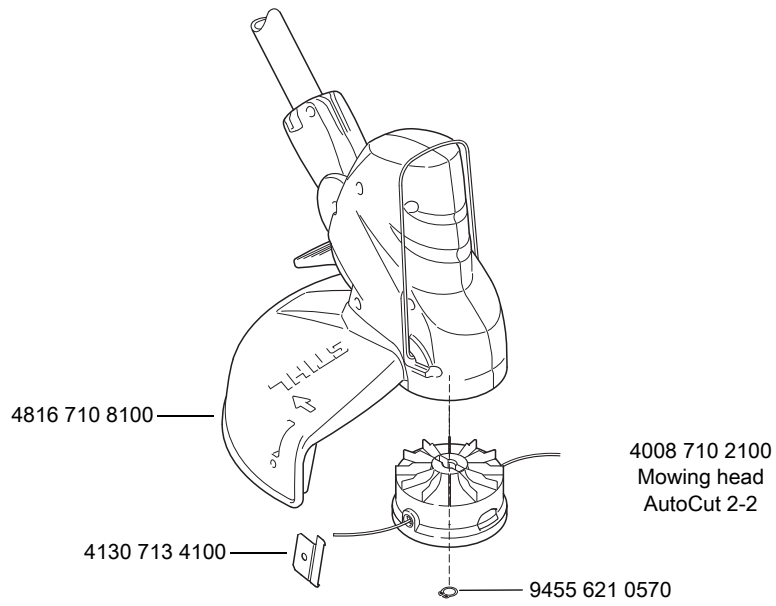

681KT796-A1

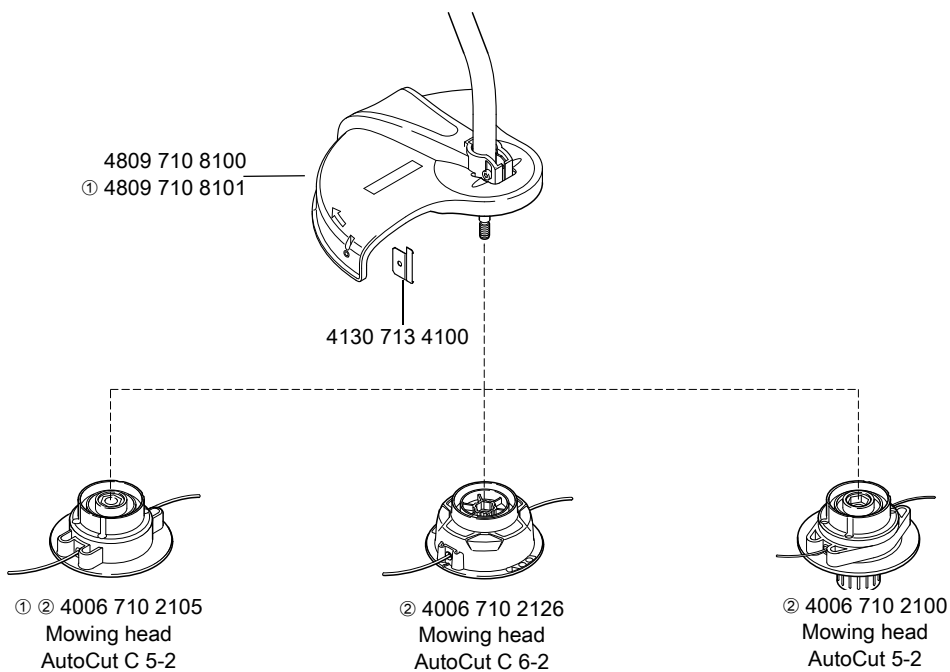

0000-GXX-3471-A0

① No longer available

② Use quiet nylon line

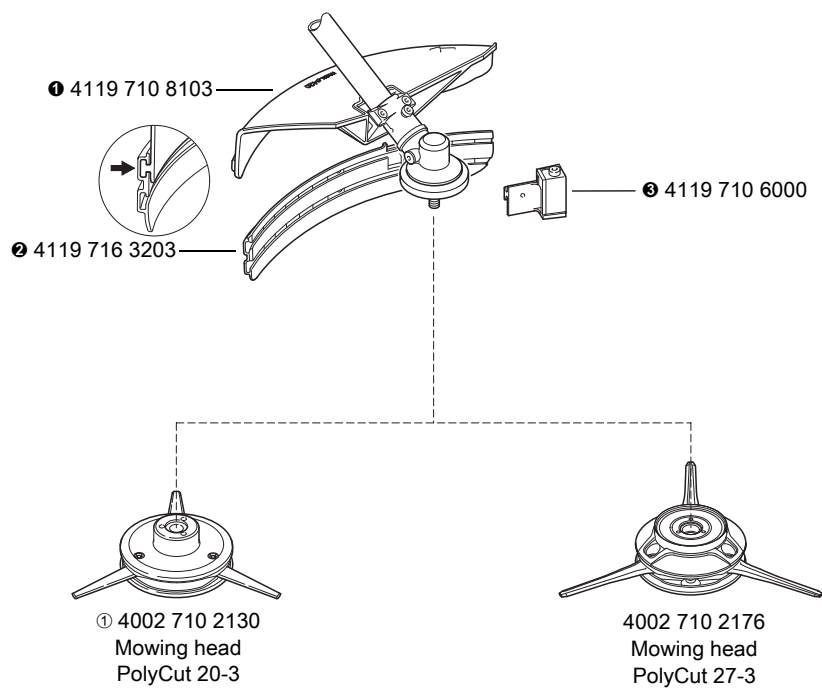

0000-GXX-5744-A0

① No longer available

① + ② + ③ = 4119 007 1027

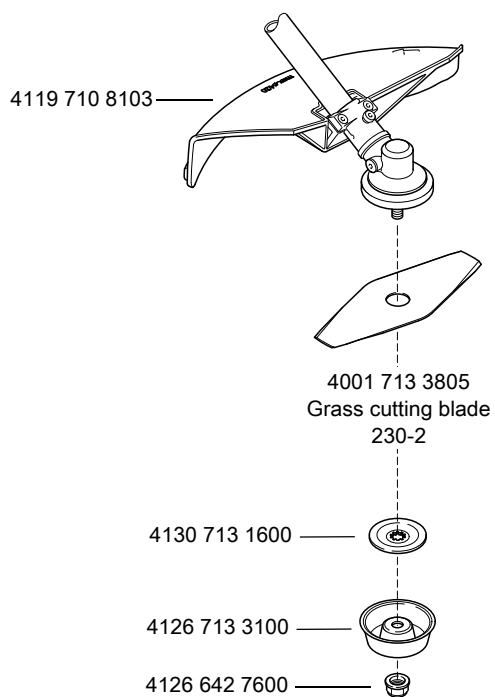

681KT585 KN

(a) from 2017

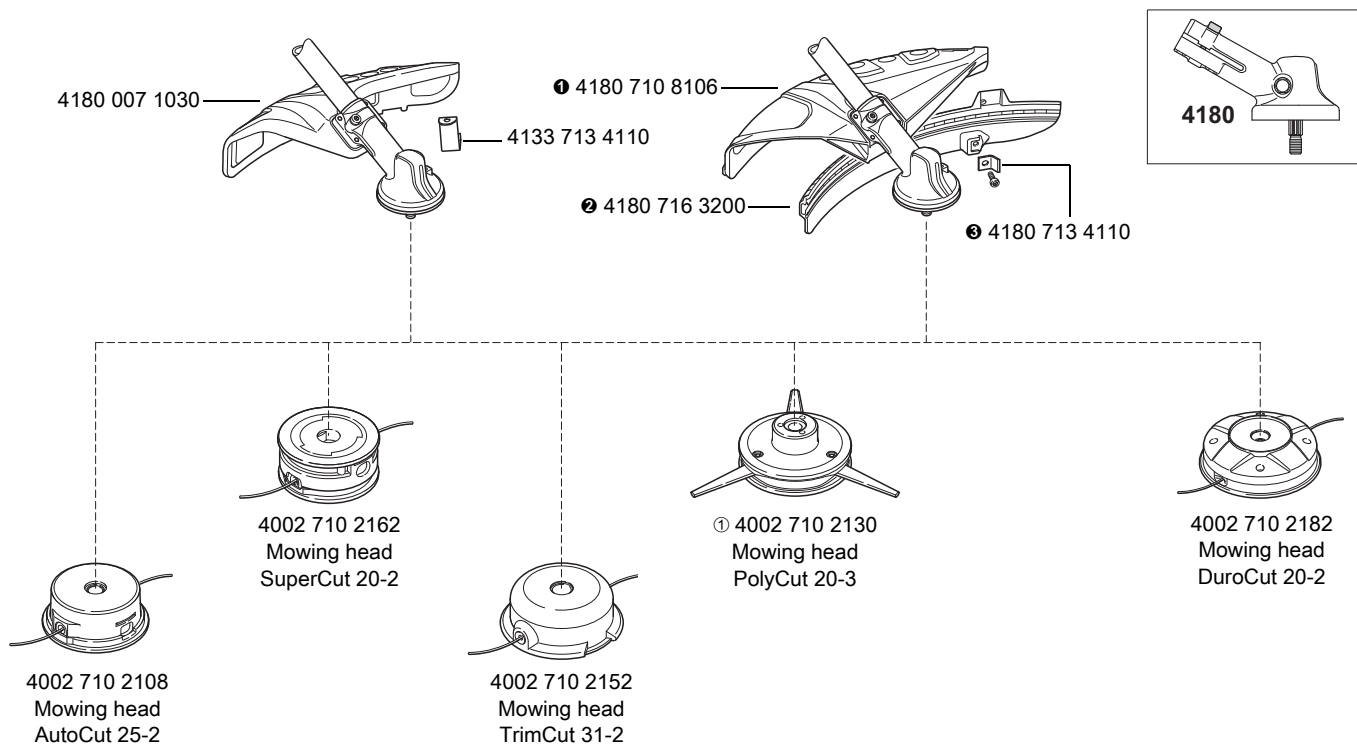

0000-GXX-5553-A0

① No longer available

① + ② + ③ = 4180 007 1028

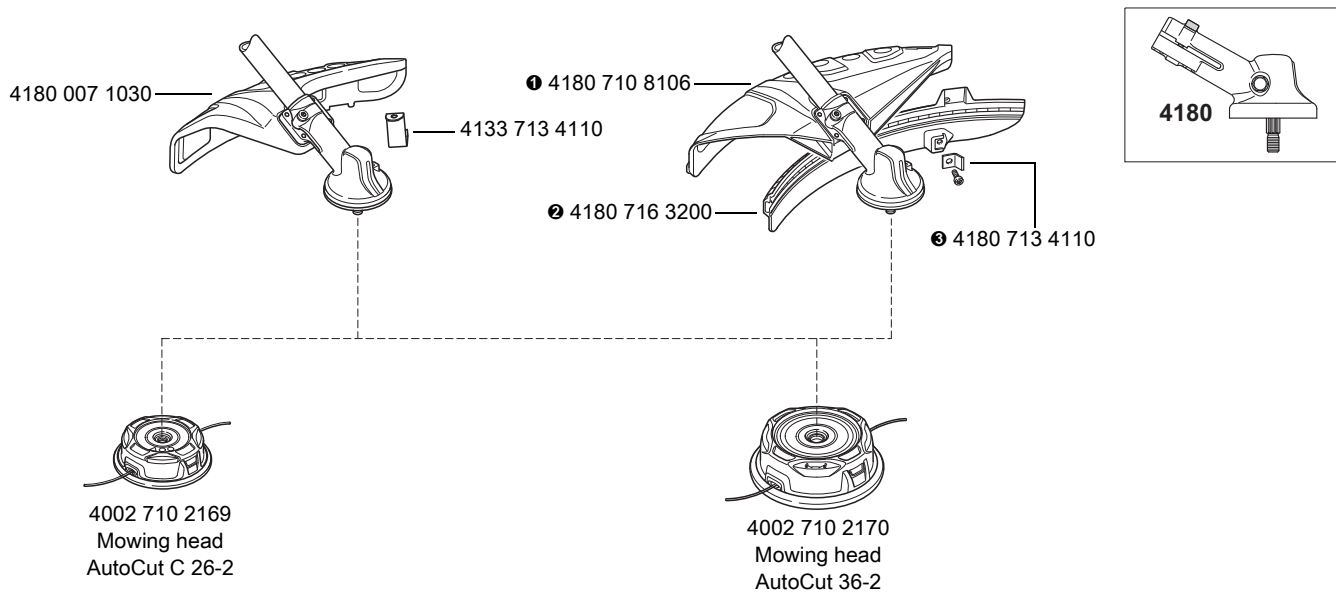

0000-GXX-5552-A0

① + ② + ③ = 4180 007 1028

(a) from 2017

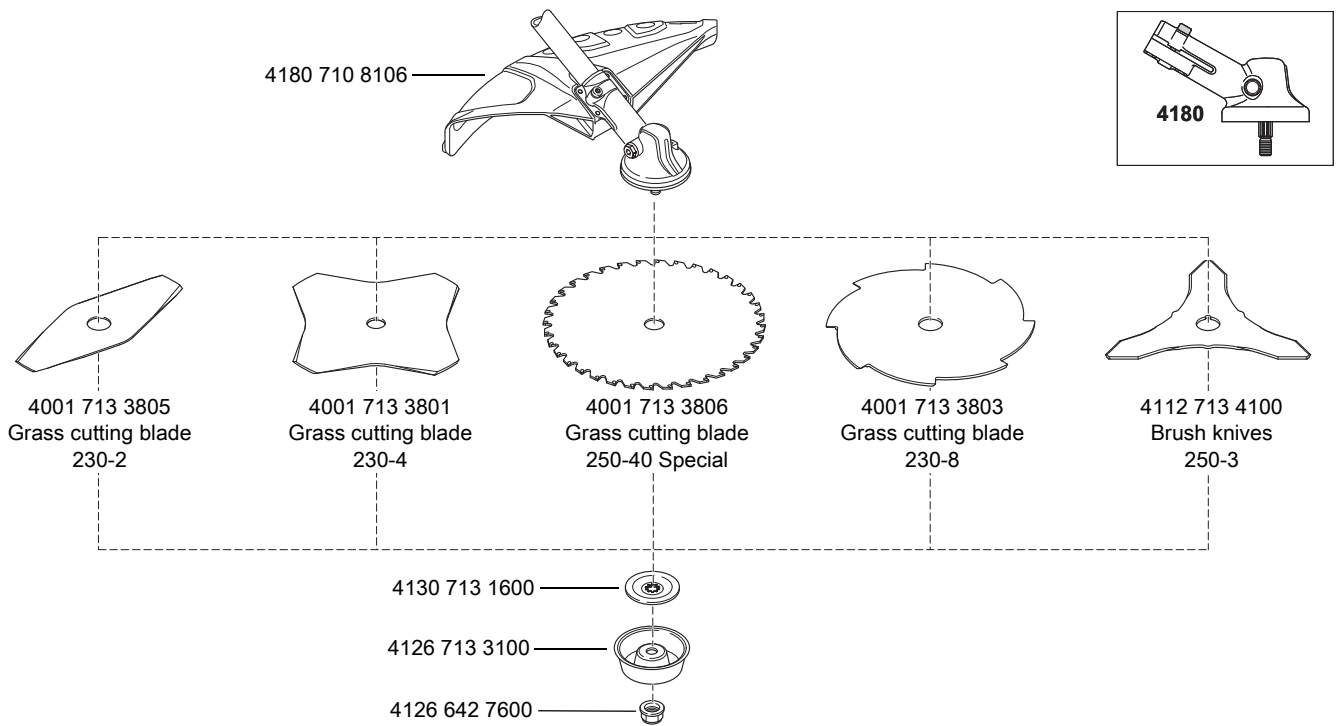

0000-GXX-5551-A0

❶ + ❷ + ❸ = 4180 007 1028

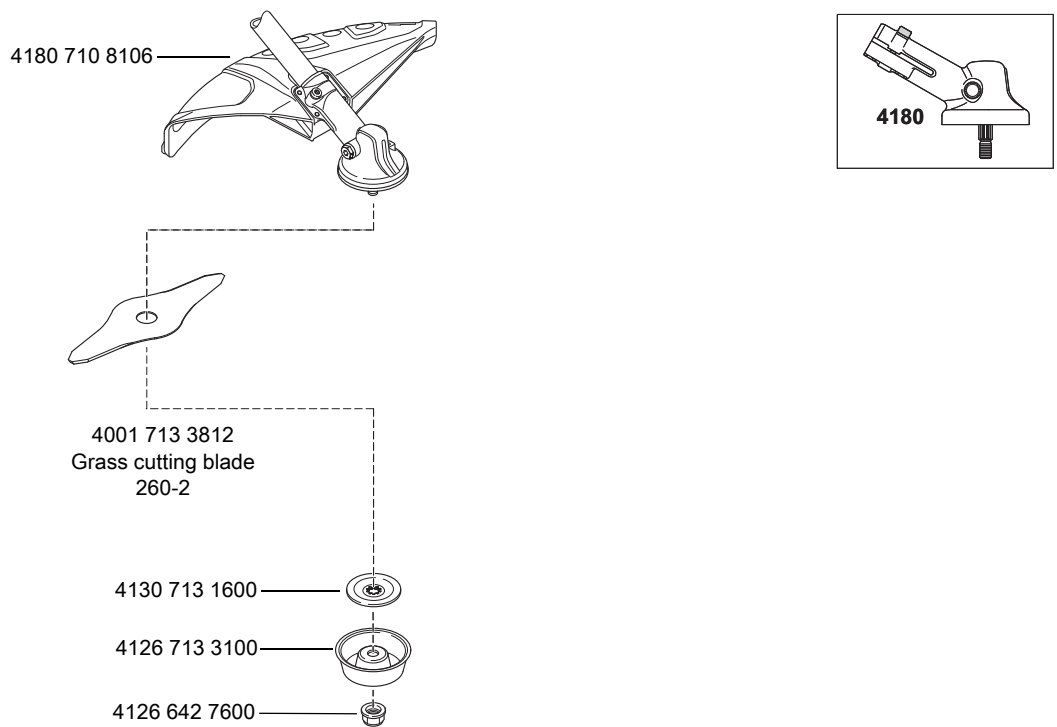

0000-GXX-5550-A0

(a) from 2017

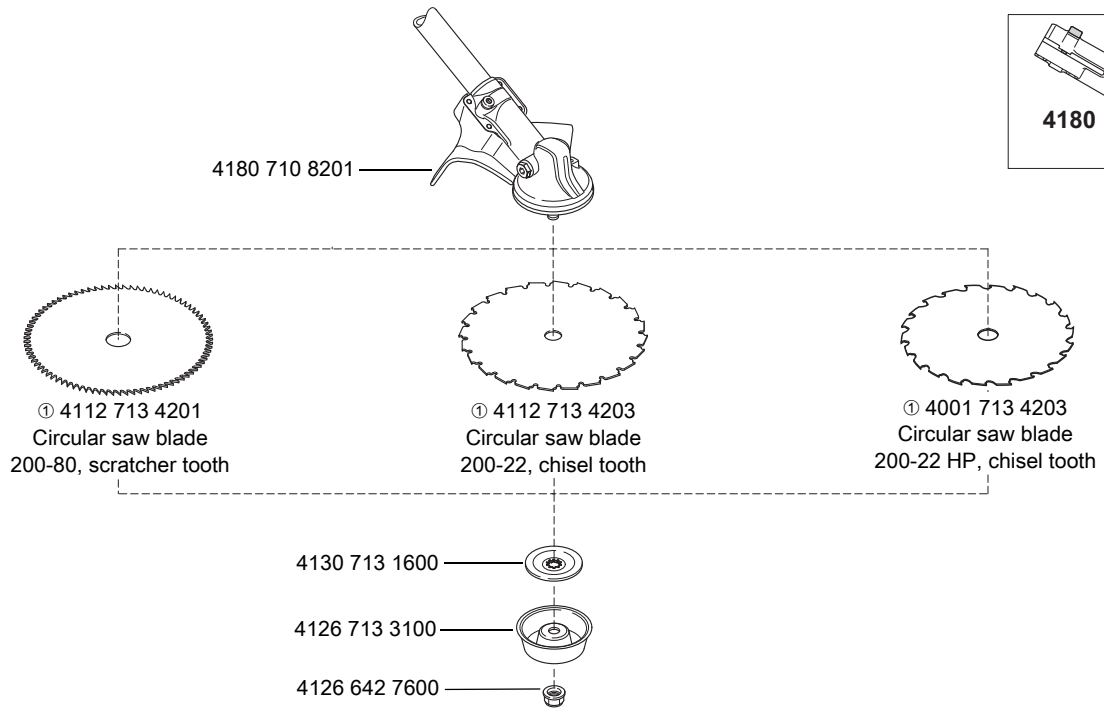

0000-GXX-5547-A0

① Not approved on brushcutters with loop handle

① Not approved on machines with loop handle

(a) up to 2017

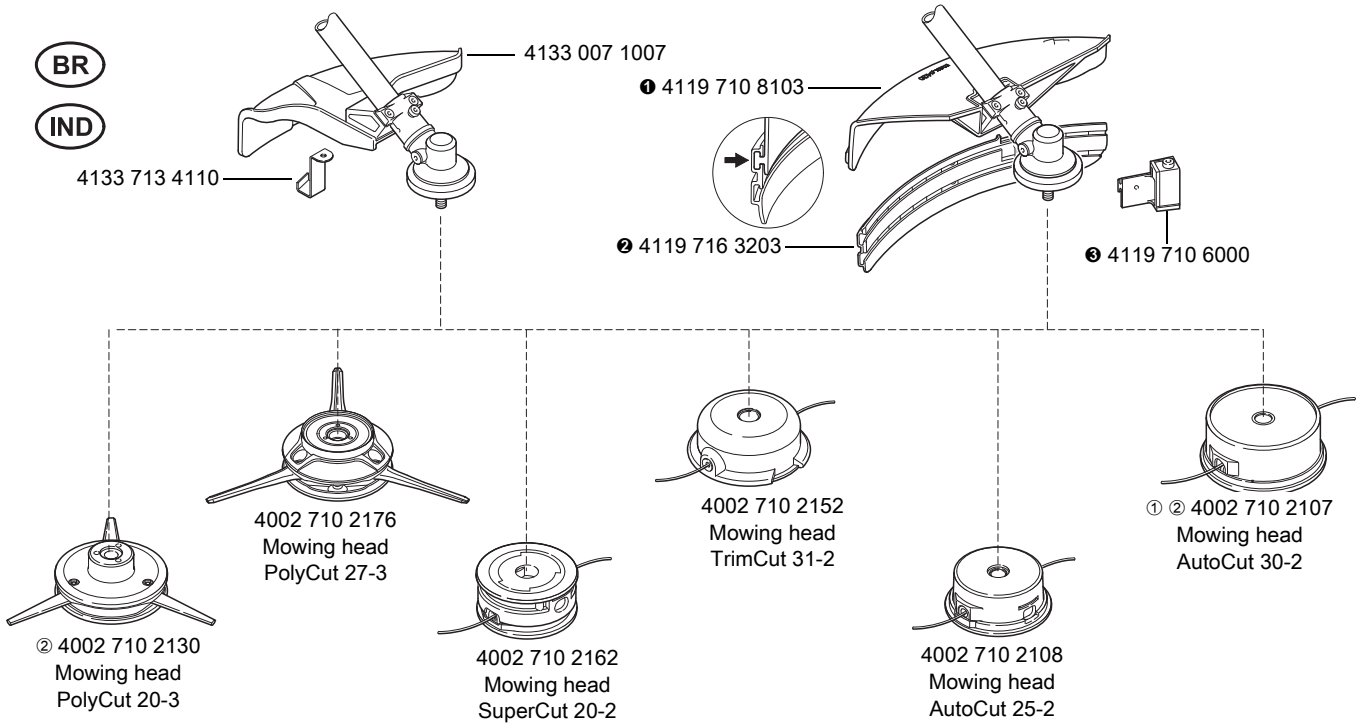

0000-GXX-5745-A0

① Not approved for KA 85, KR 85

② No longer available

① + ② + ③ = 4119 007 1027

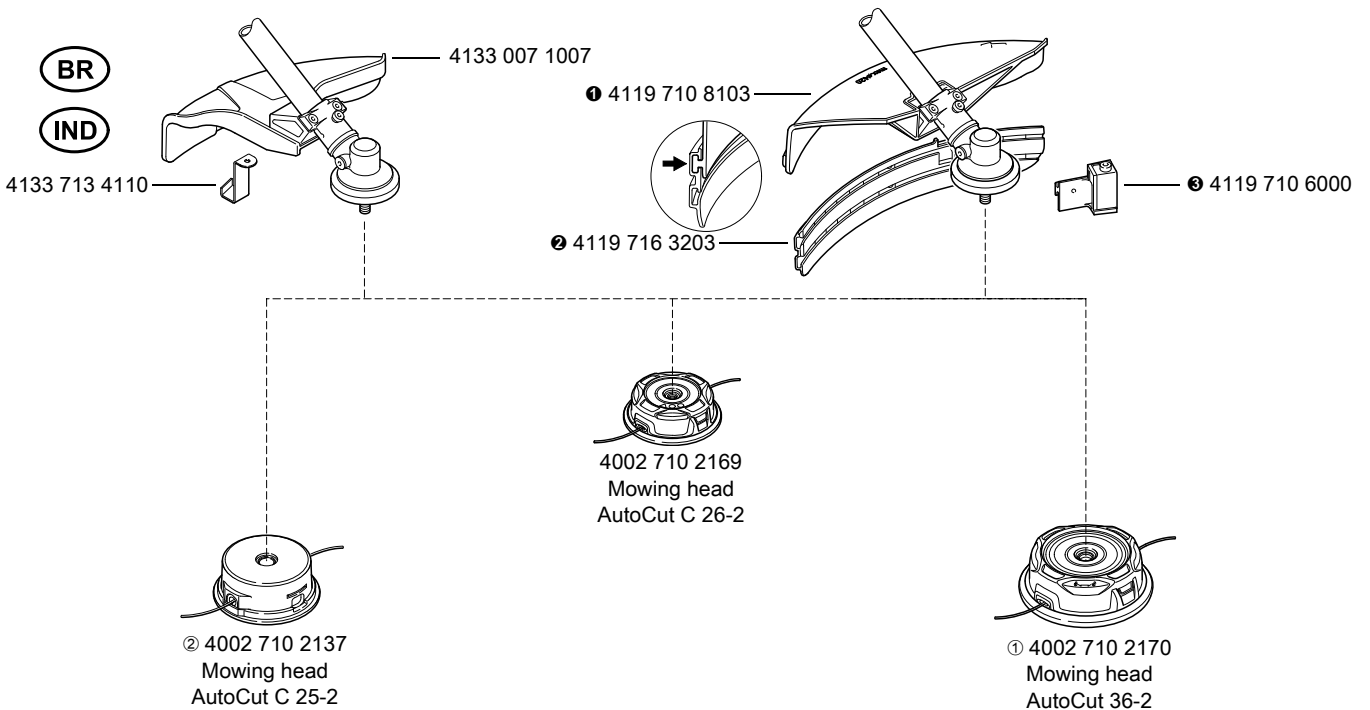

0000-GXX-3472-A0

① Not approved for KA 85, KR 85

② No longer available

① + ② + ③ = 4119 007 1027

(a) up to 2017

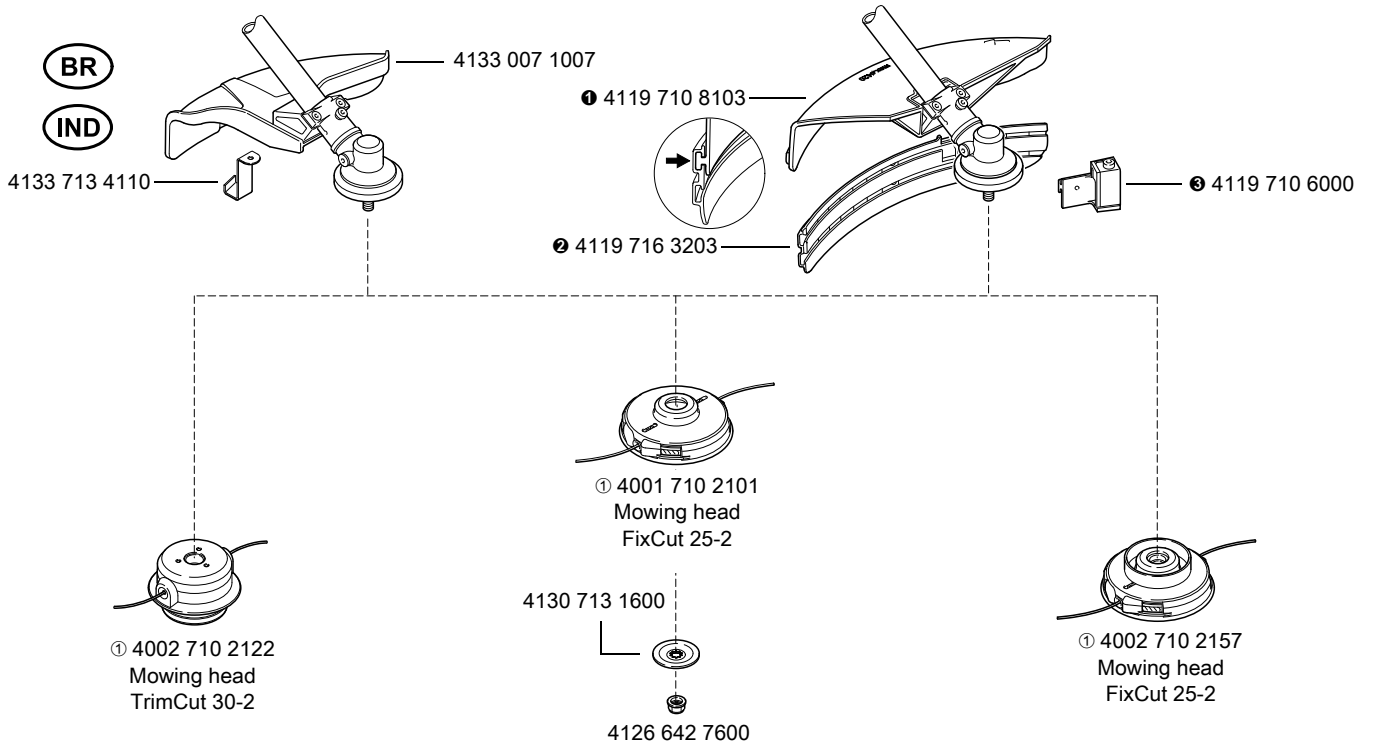

0 000-GXX-3473-A0

① No longer available

① + ② + ③ = 4119 007 1027

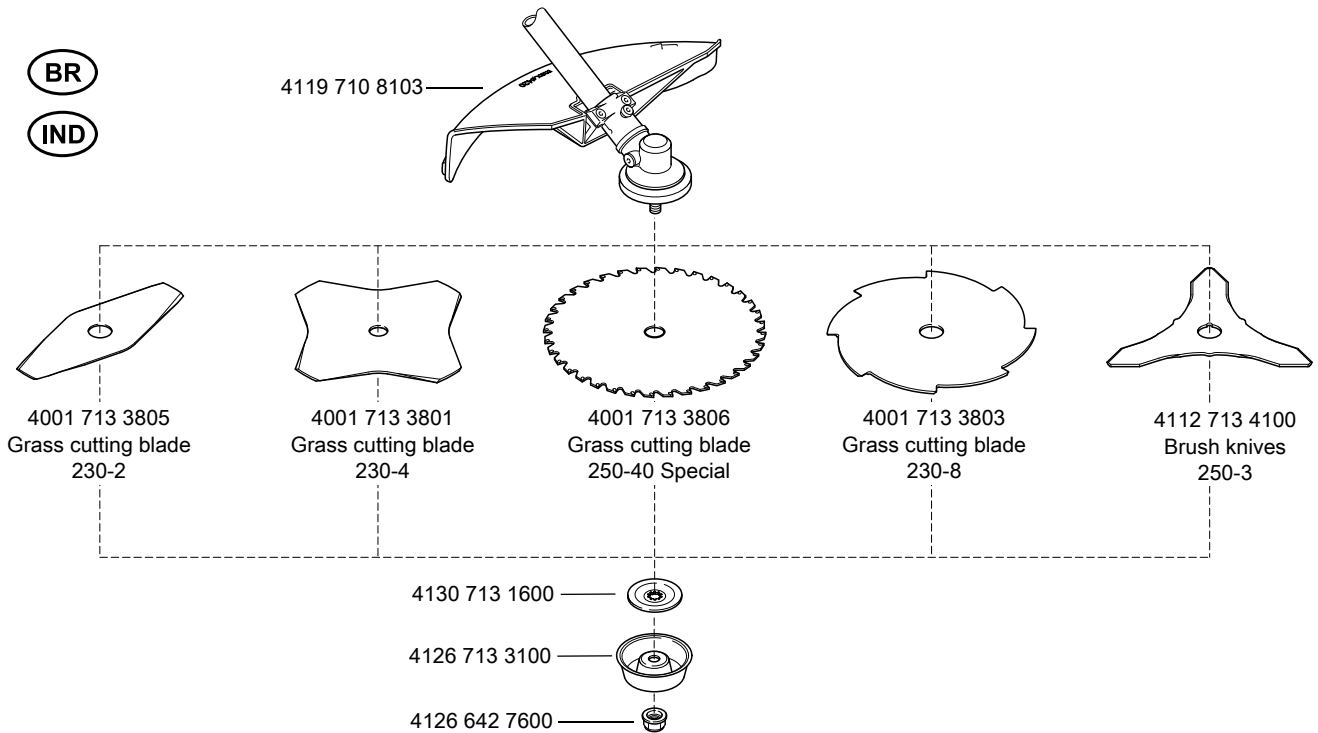

381KT1001 KN

(a) up to 2017

BR

IND

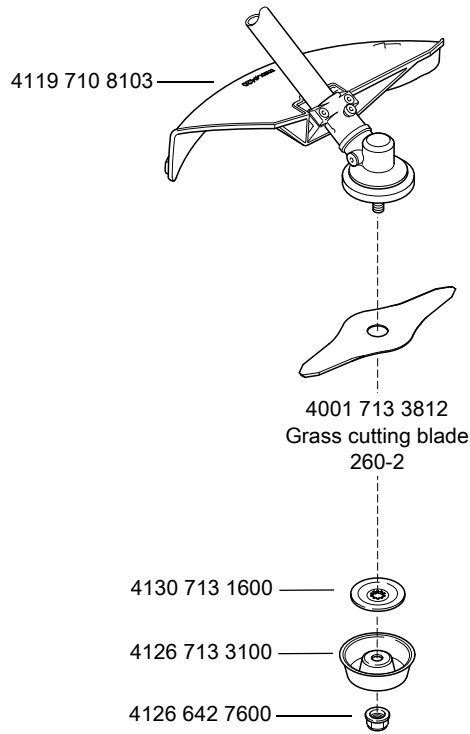

681KT1090-KN

BR

IND

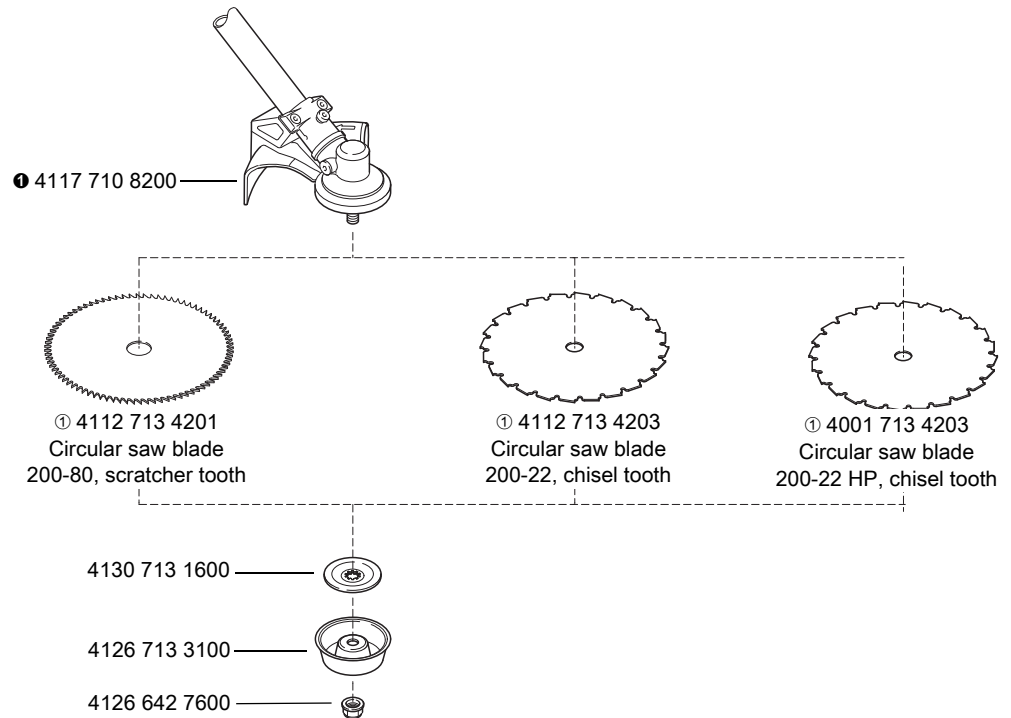

381KT1002-A1

① Not approved on machines with loop handle

① + Transport guard = 4126 007 1002

(a) from 2015

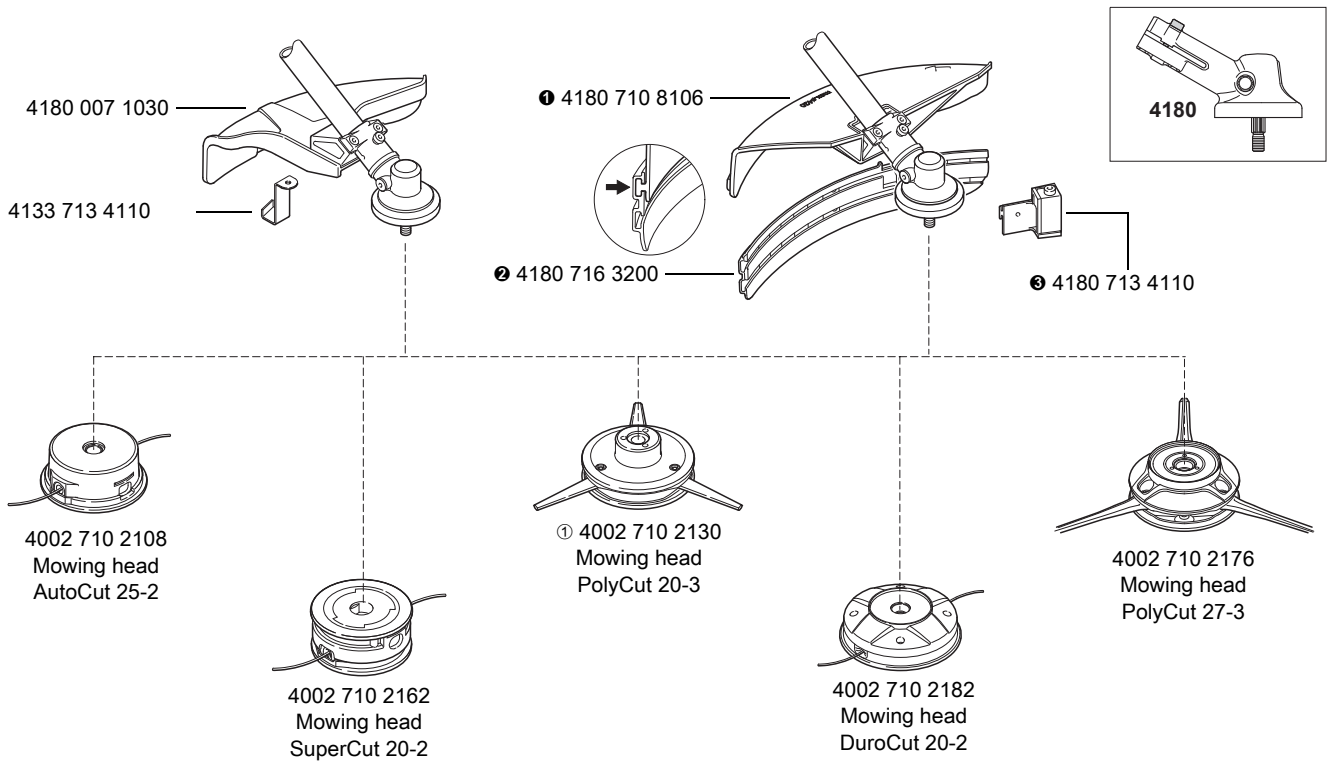

0000-GXX-5747-A0

① No longer available

① + ② + ③ = 4180 007 1028

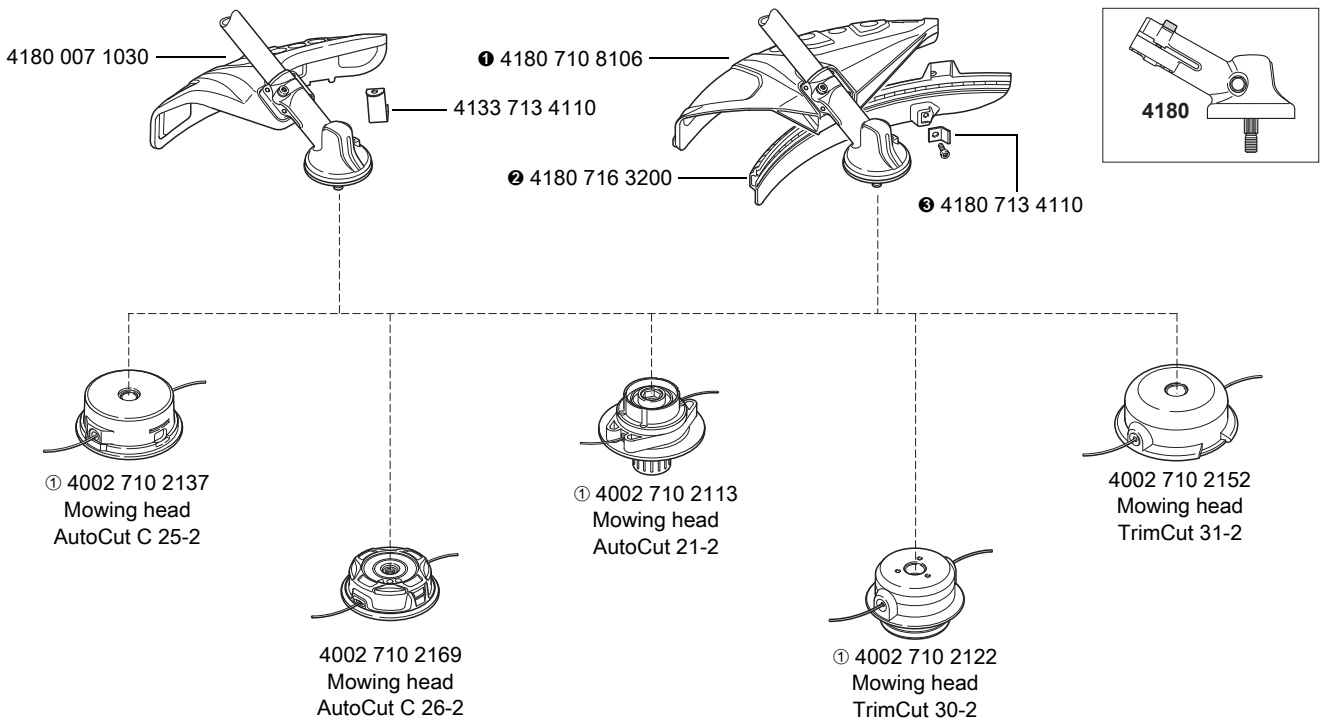

0000-GXX-3474-A1

① No longer available

① + ② + ③ = 4180 007 1028

(a) from 2015

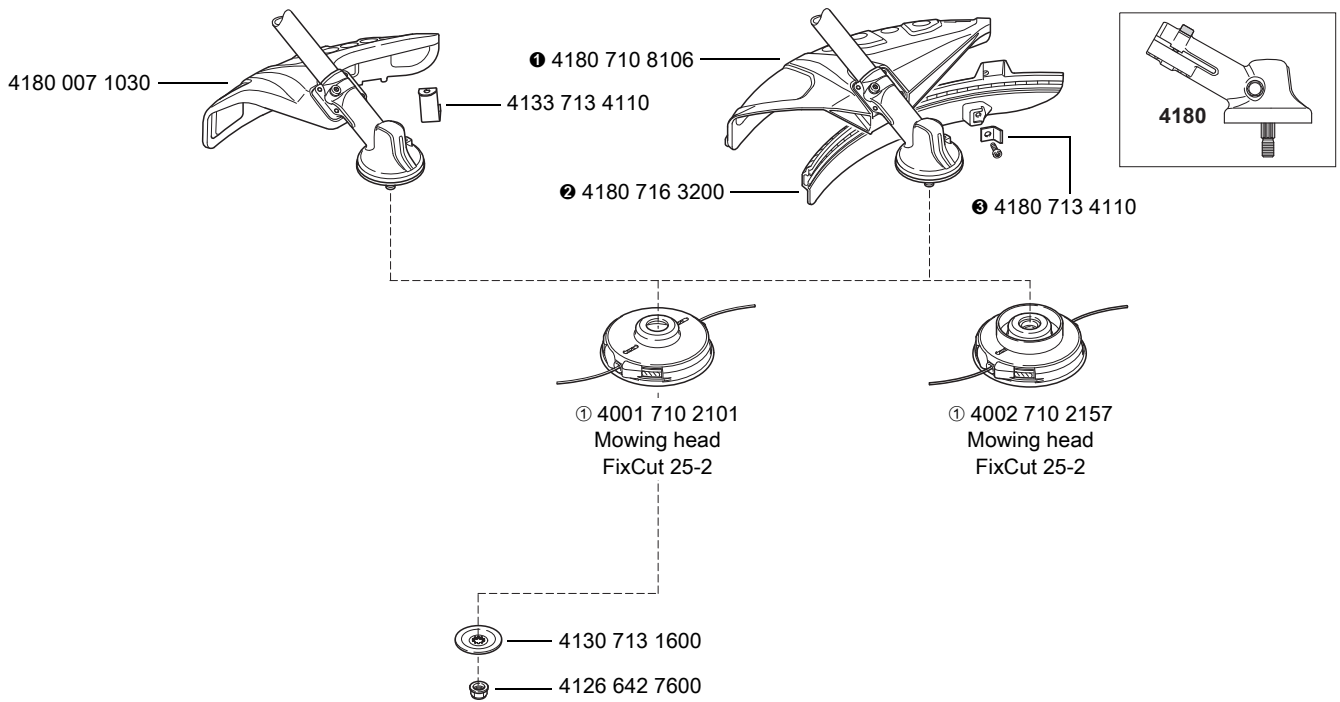

681KT992-A1

① No longer available

① + ② + ③ = 4180 007 1028

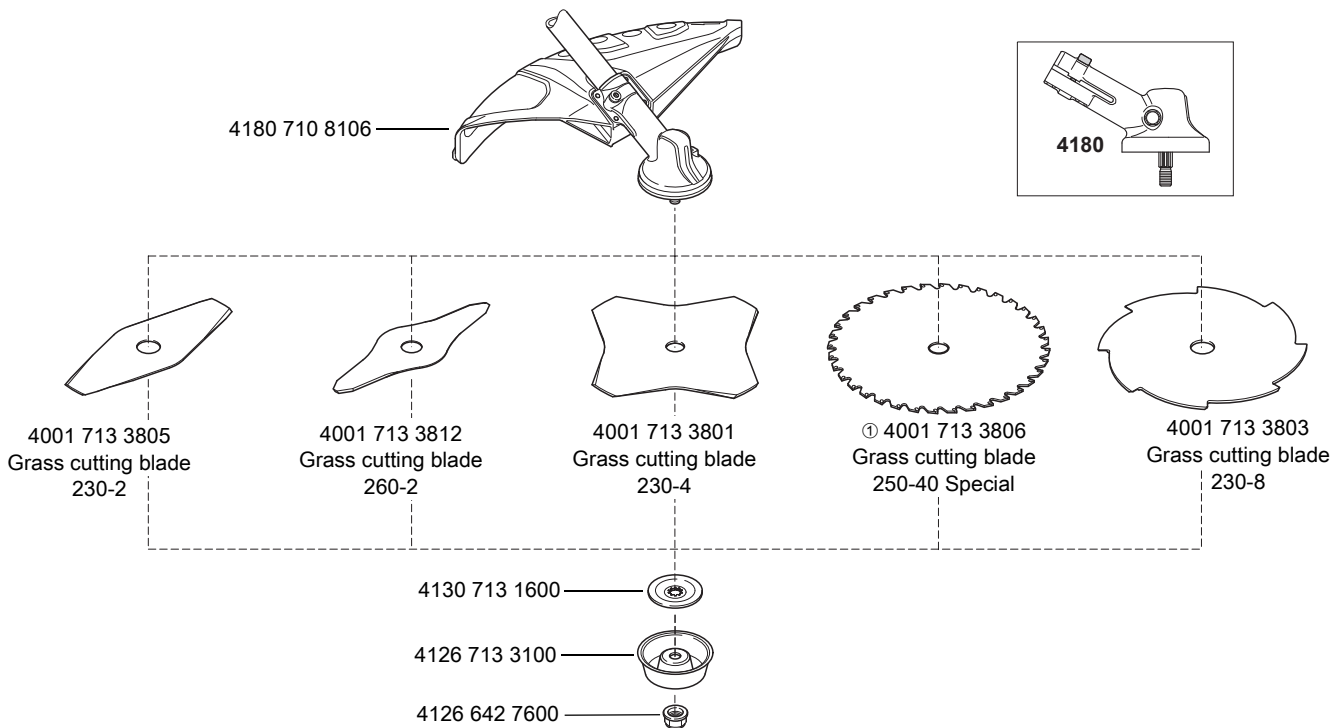

381KT1091 KN

① Not approved for KM 56

(a) up to 2015

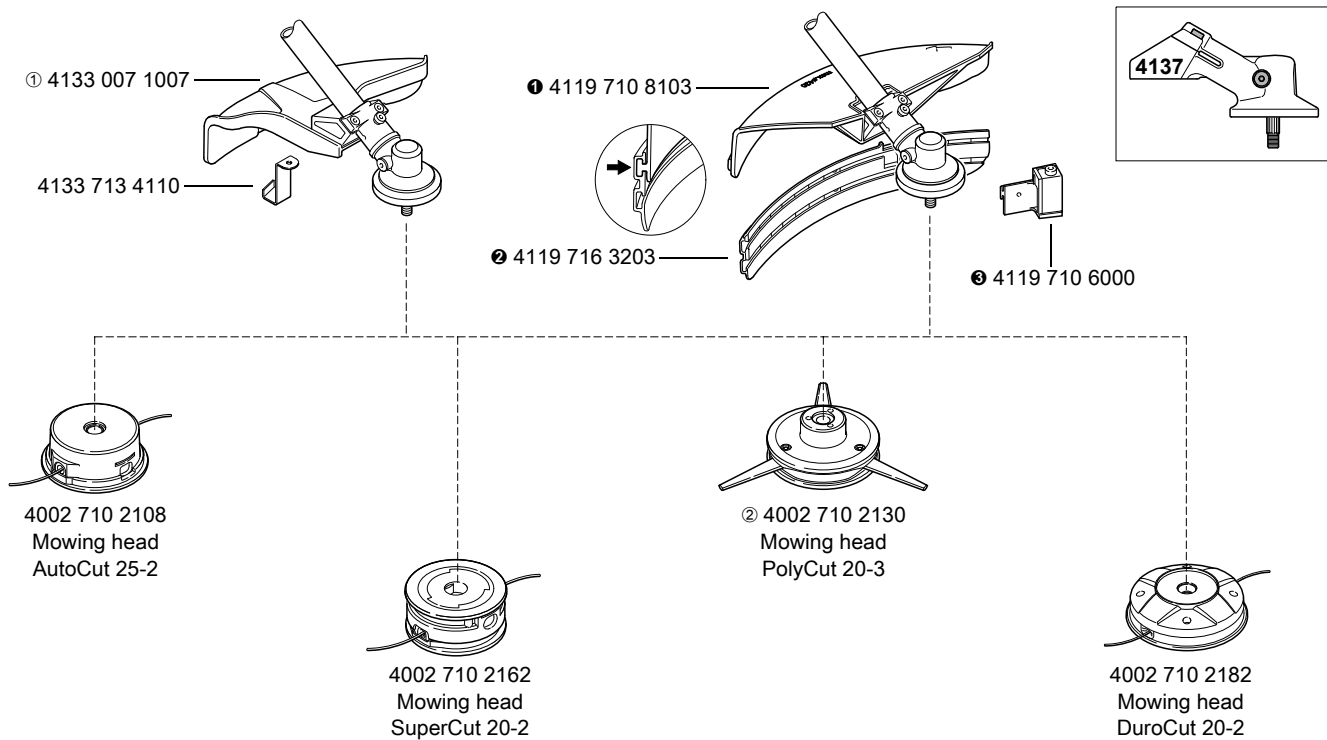

681KT805 KN

① Approved in AUS, NZ only: 4133 007 1008

② No longer available

① + ② + ③ = 4119 007 1027

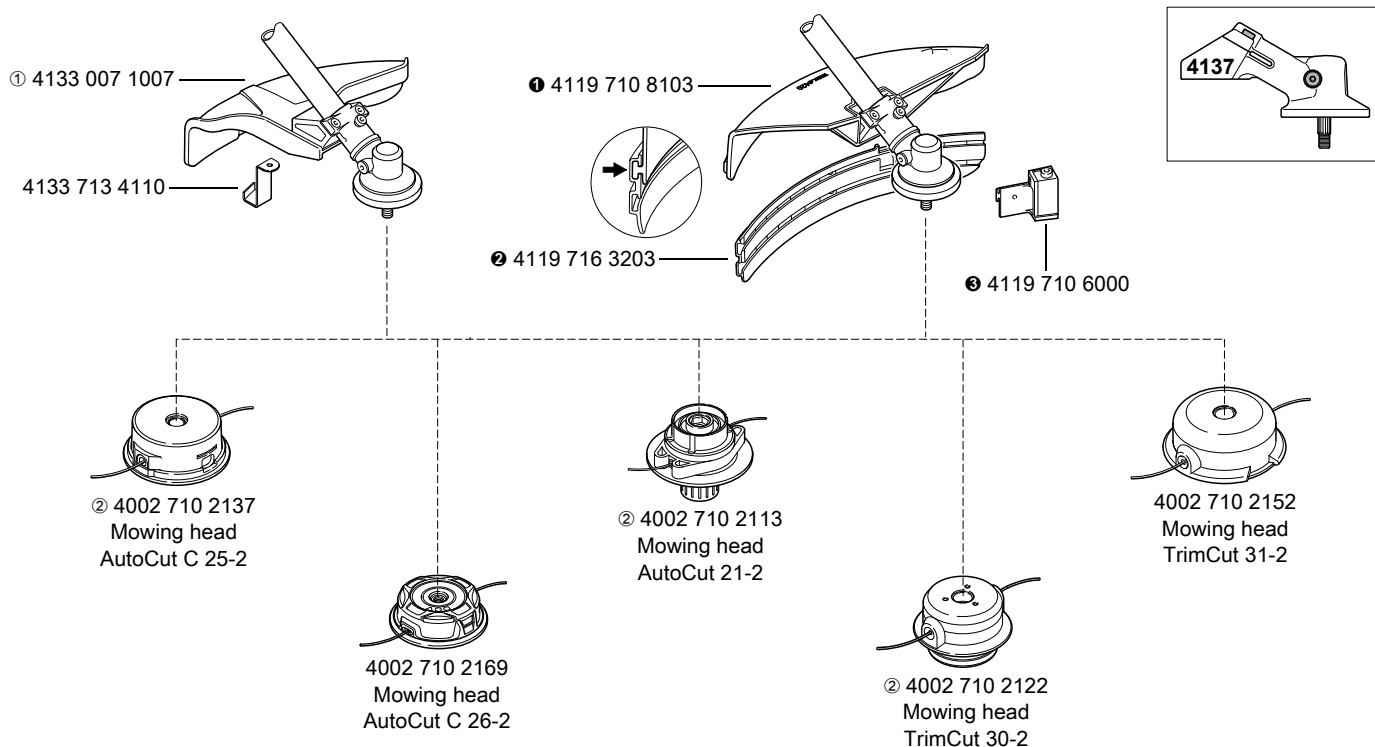

0000-GXX-3475-A0

① Approved in AUS, NZ only: 4133 007 1008

② No longer available

① + ② + ③ = 4119 007 1027

(a) up to 2015

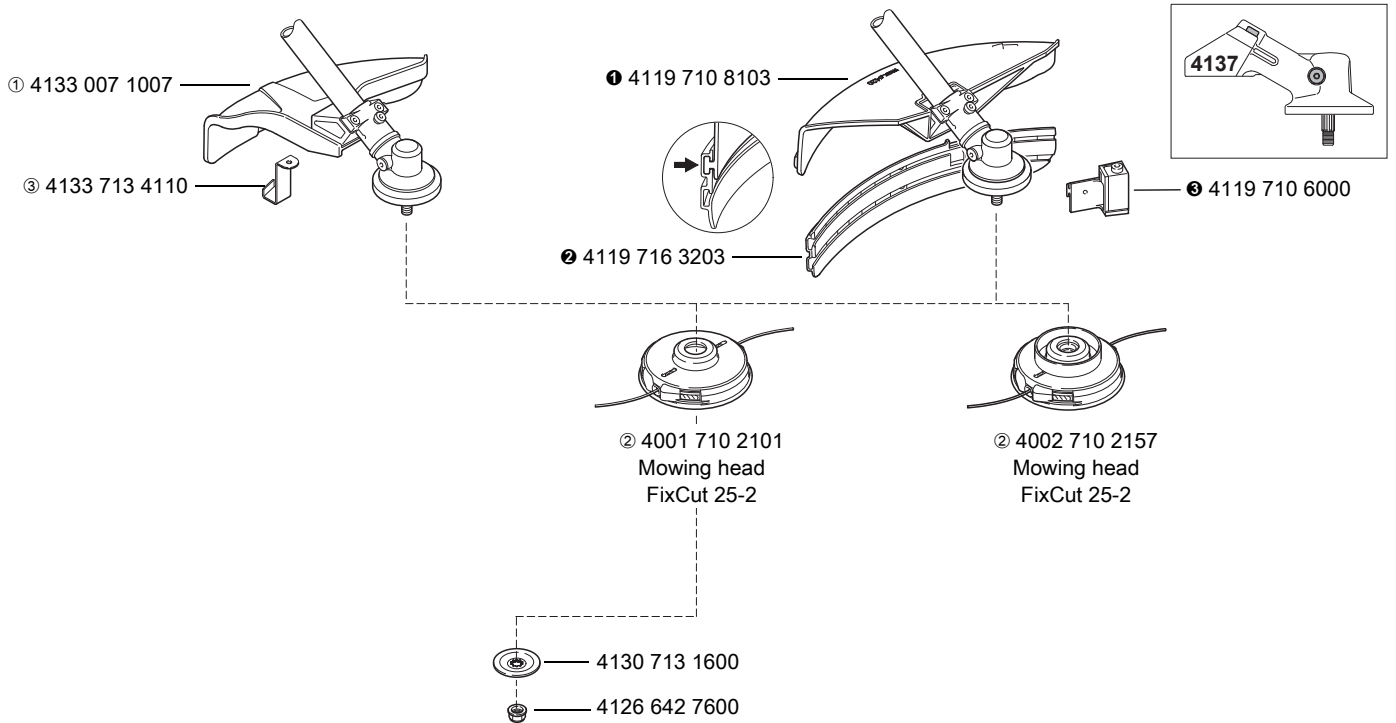

681KT913-A1

① Approved in AUS, NZ only: 4133 007 1008

② No longer available

① + ② + ③ = 4119 007 1027

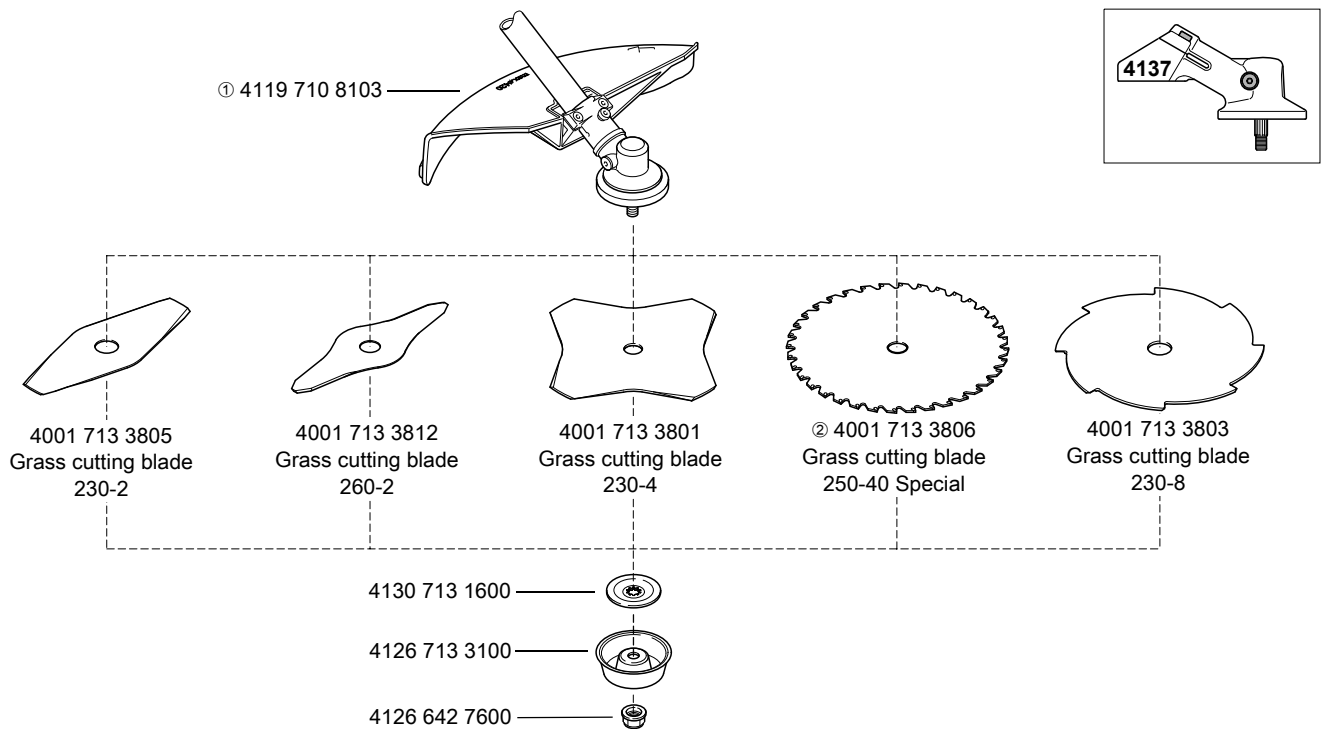

681KT1092-KN

① Deflector for AUS, NZ see illustration marked "AUS, NZ"

② Not approved for KM 56

(a) up to 2015

AUS NZ

4133 007 1008

4133 713 4110

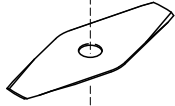
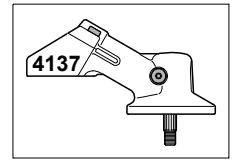
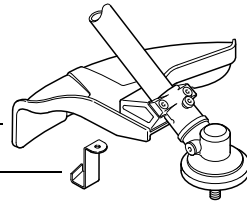

4001 713 3805
Grass cutting blade
230-2

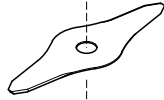

4001 713 3812
Grass cutting blade
260-2

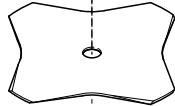

4001 713 3801
Grass cutting blade
230-4

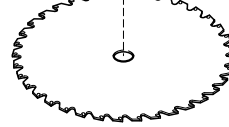

4001 713 3806
Grass cutting blade
250-40 Special

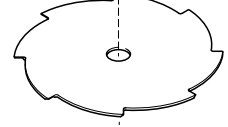

4001 713 3803
Grass cutting blade
230-8

4130 713 1600



4126 713 3100



4126 642 7600



661KT1093 KN

(a) from 2018

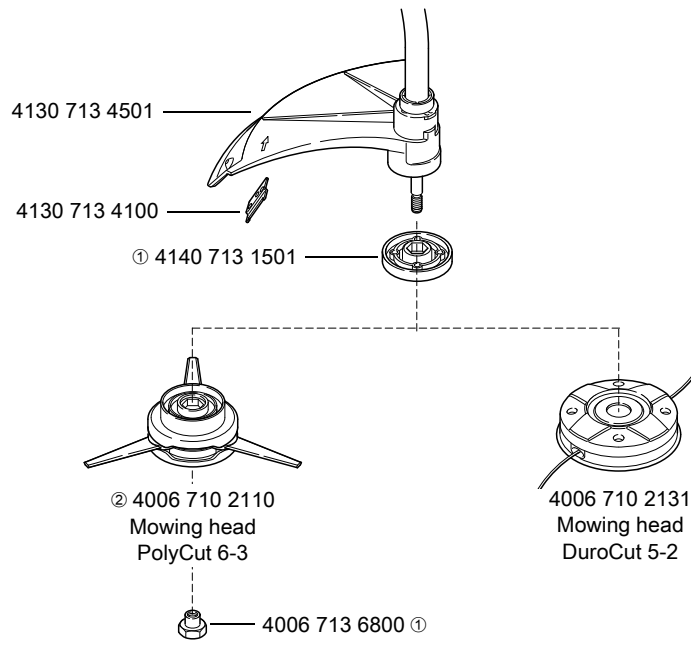

0000-GXX-8902-A0

① Part supplied with mowing head

② No longer available

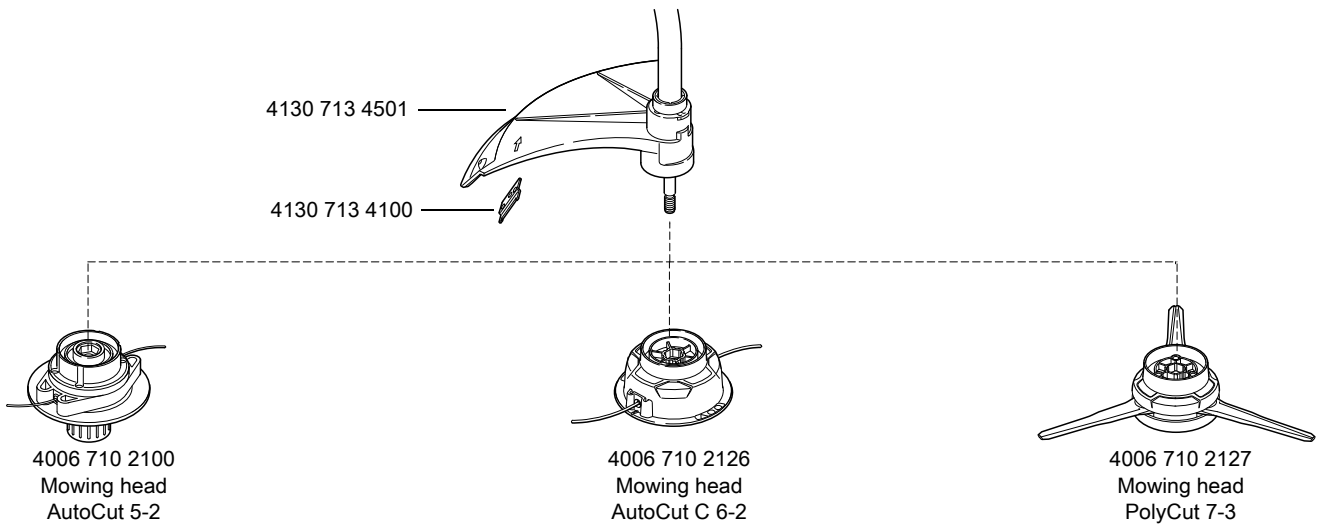

0000-GXX-8903-A0

(a) up to 2017

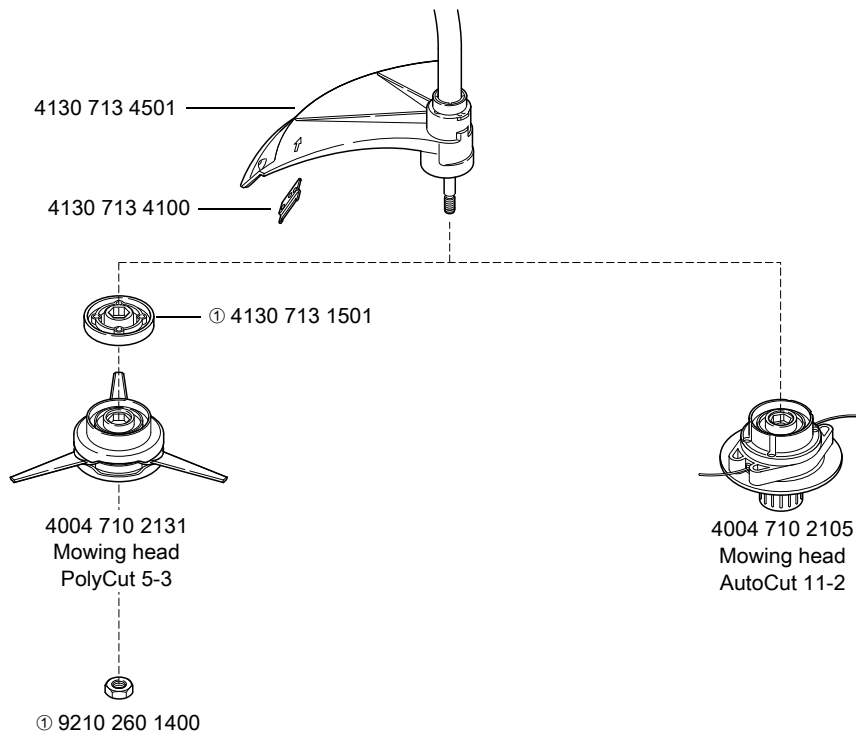

681KT923 KN

① Part supplied with mowing head

(a) from 2015

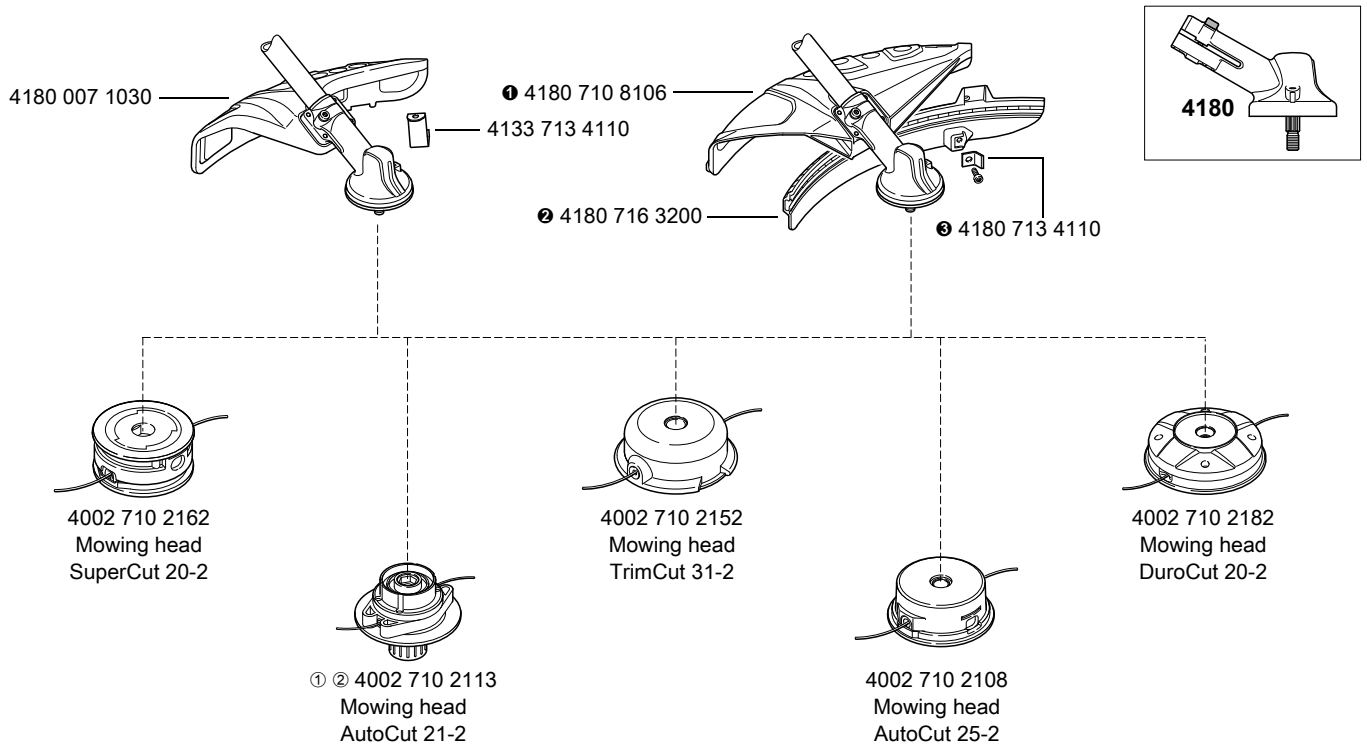

681KT994 KN

① Not approved for KM 130, 131

② No longer available

① + ② + ③ = 4180 007 1028

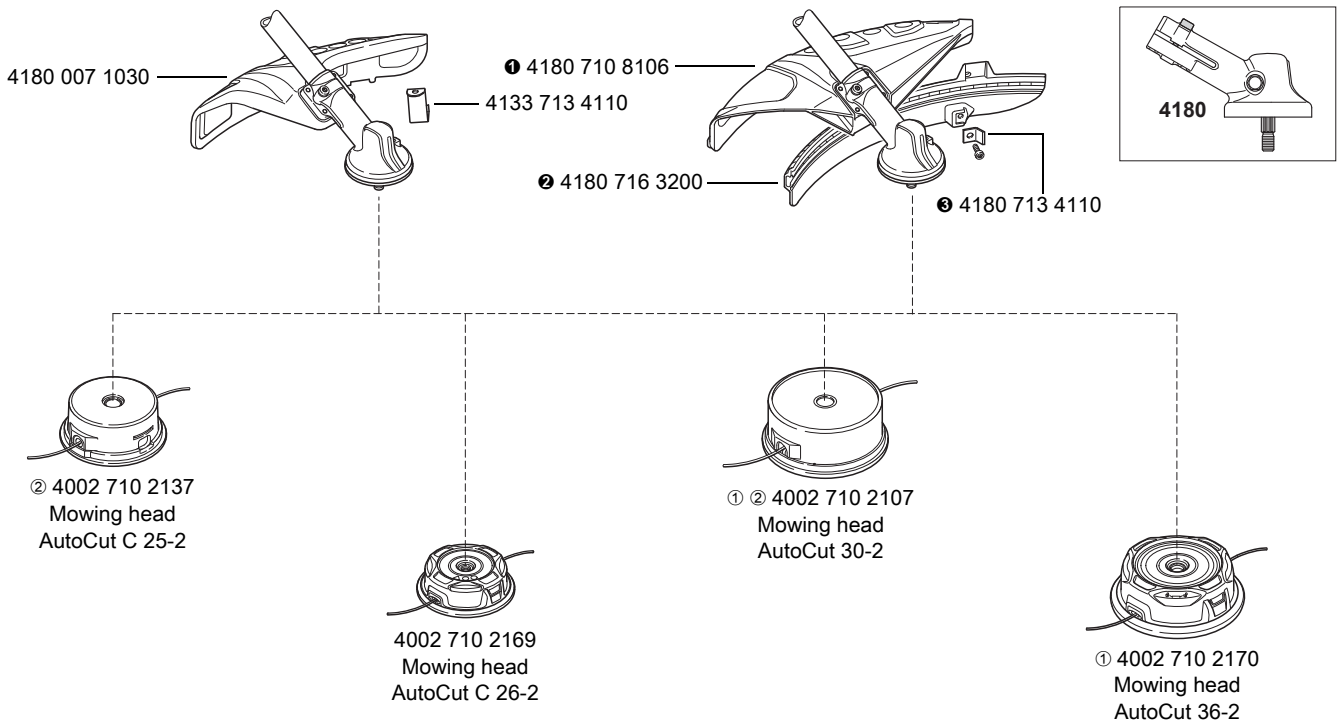

0000-GXX-3476-A1

① Approved only for KM 130, 131

② No longer available

① + ② + ③ = 4180 007 1028

(a) from 2015

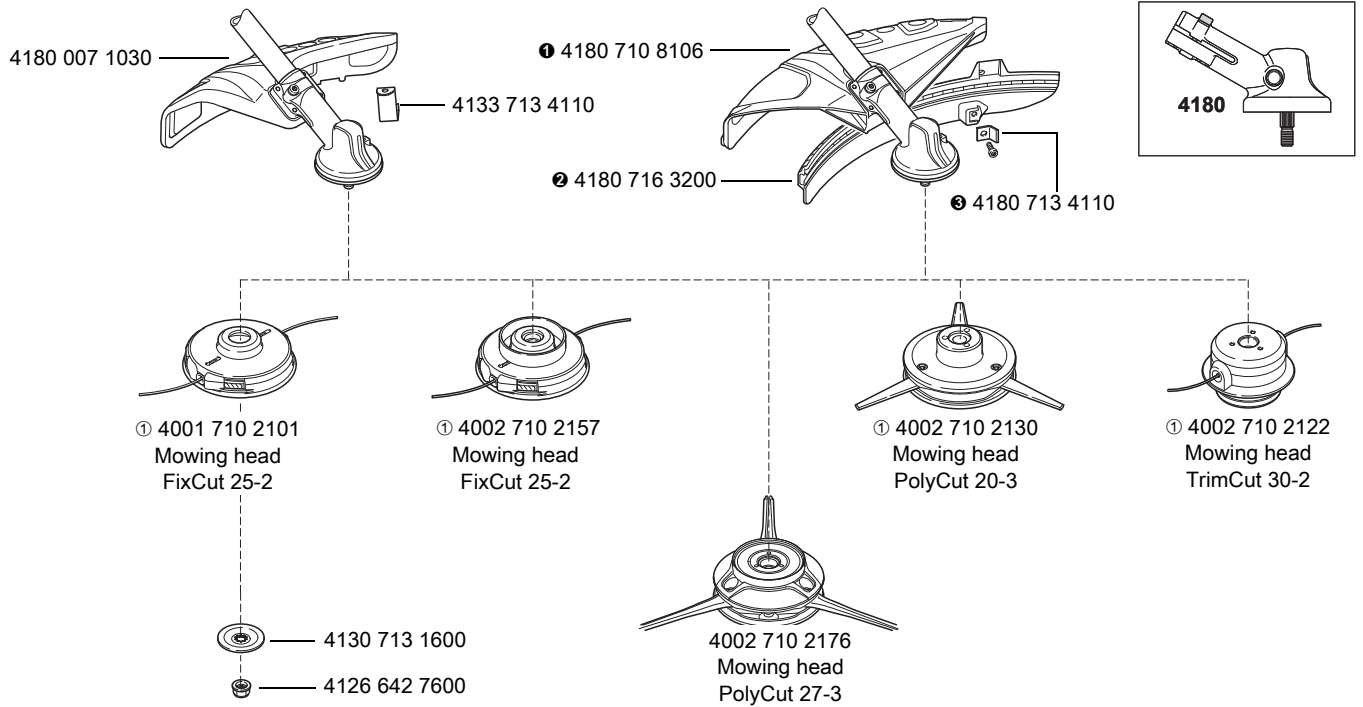

0000-GXX-5748-A0

① No longer available

❶ + ❷ + ❸ = 4180 007 1028

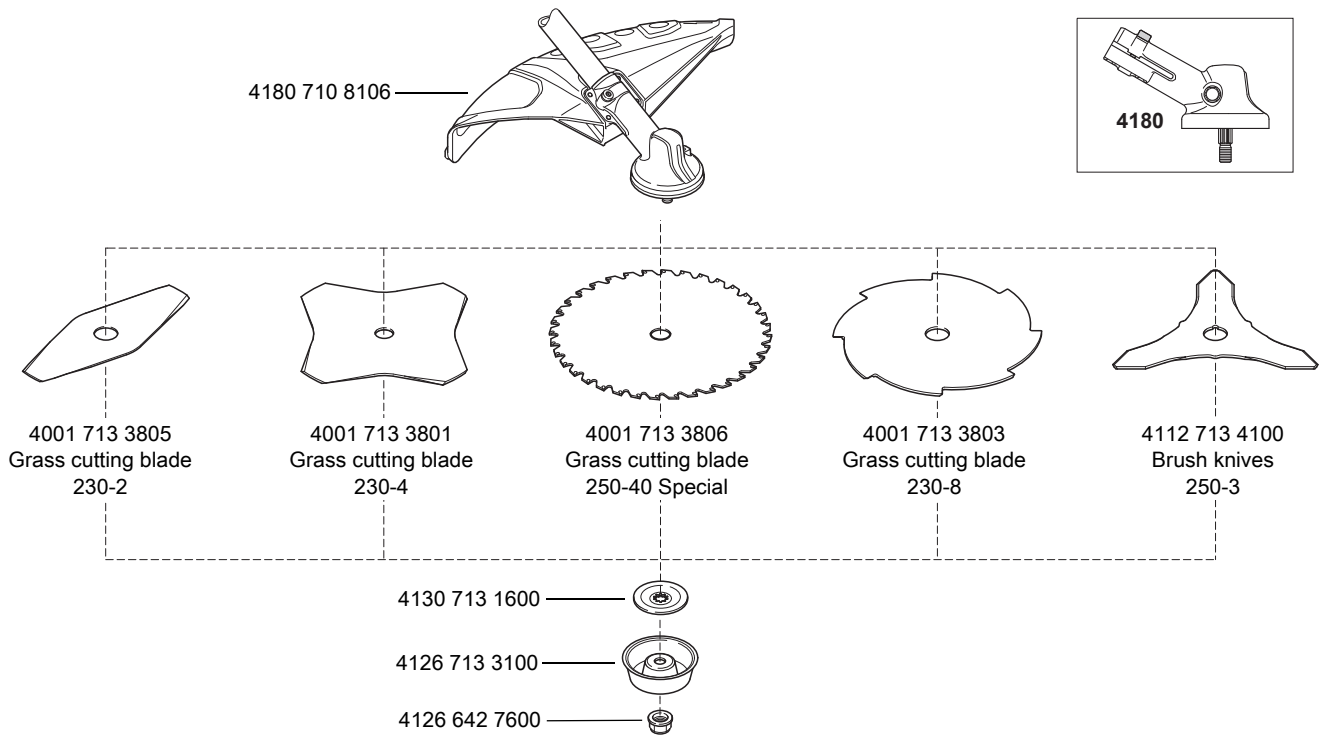

681KT997-A1

(a) from 2015

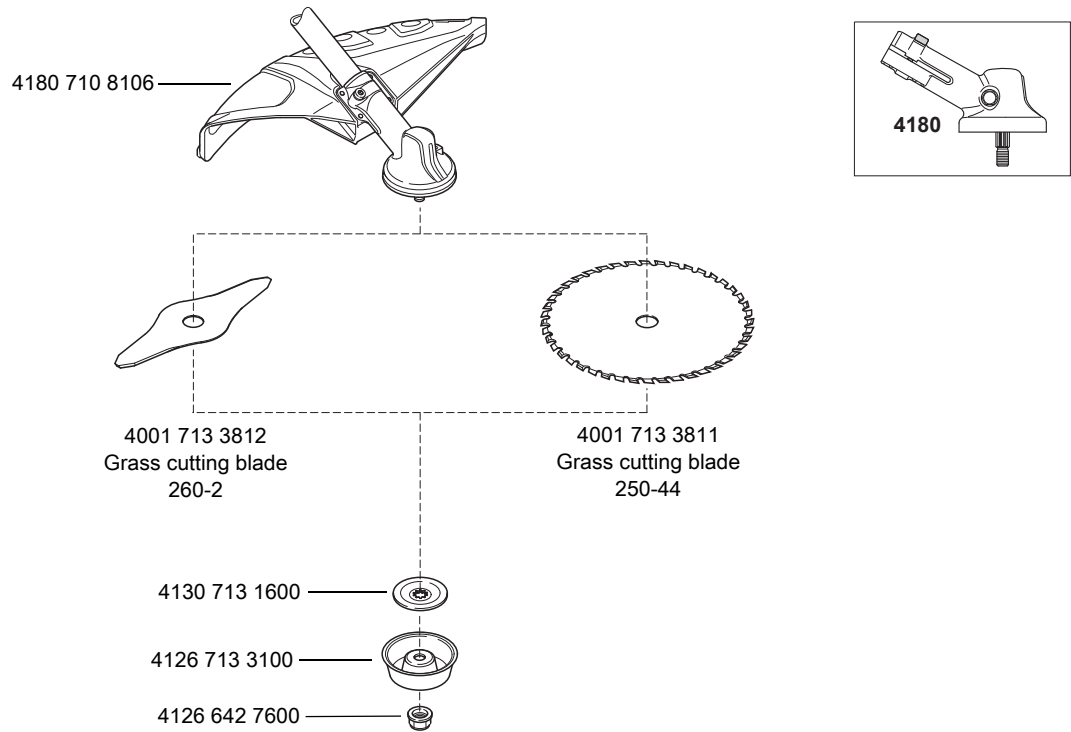

681KT1095-A1

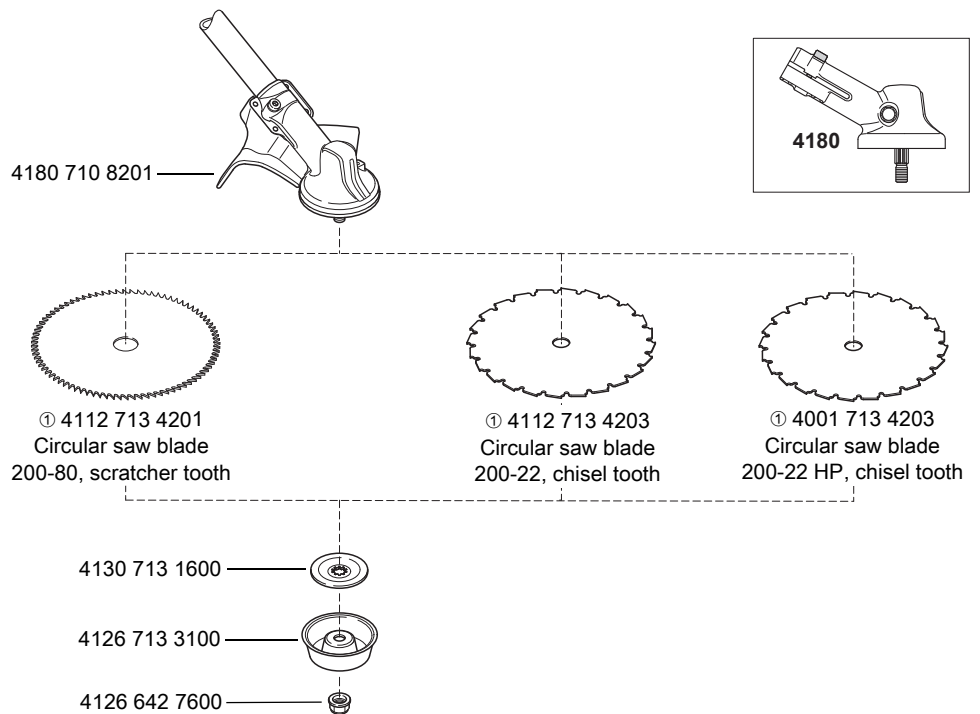

681KT998-A1

① Not approved on brushcutters with loop handle

(a) up to 2015

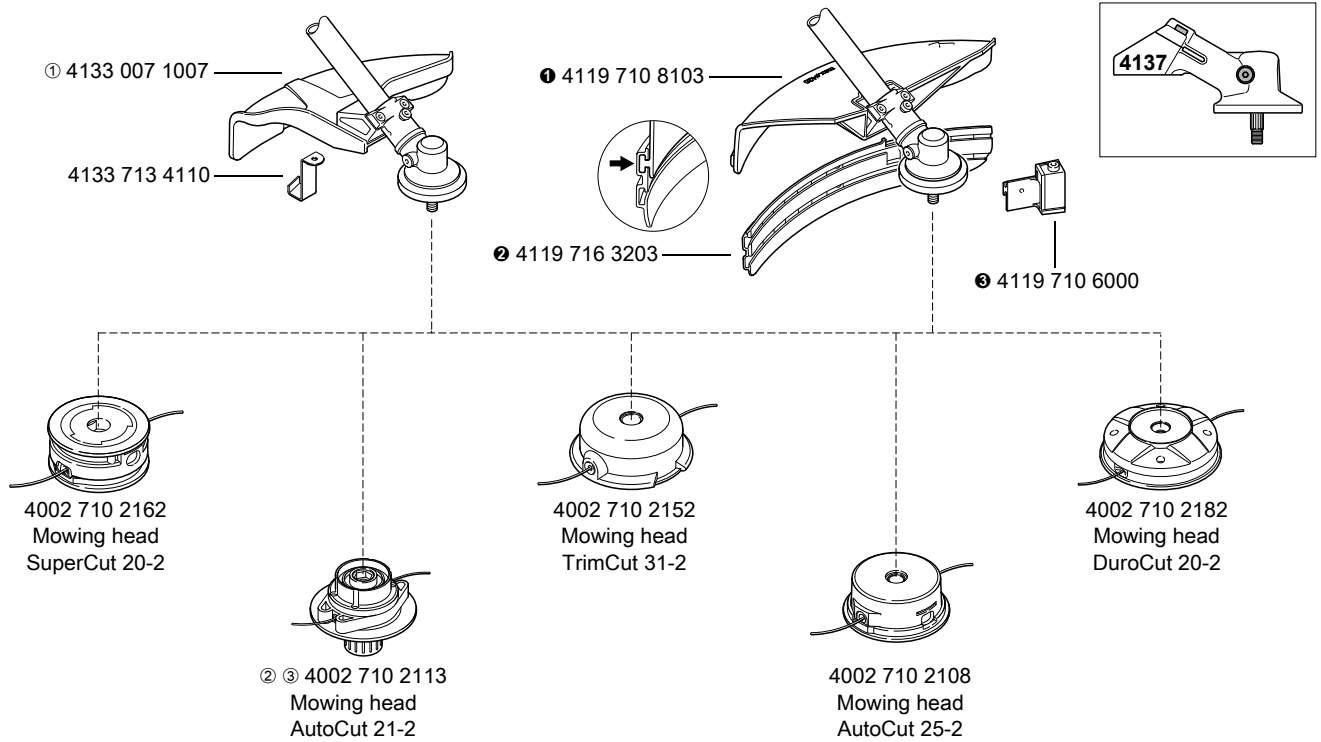

681KT915 KN

① Approved in AUS, NZ only: 4133 007 1008

① + ② + ③ = 4119 007 1027

② Not approved for KM 130

③ No longer available

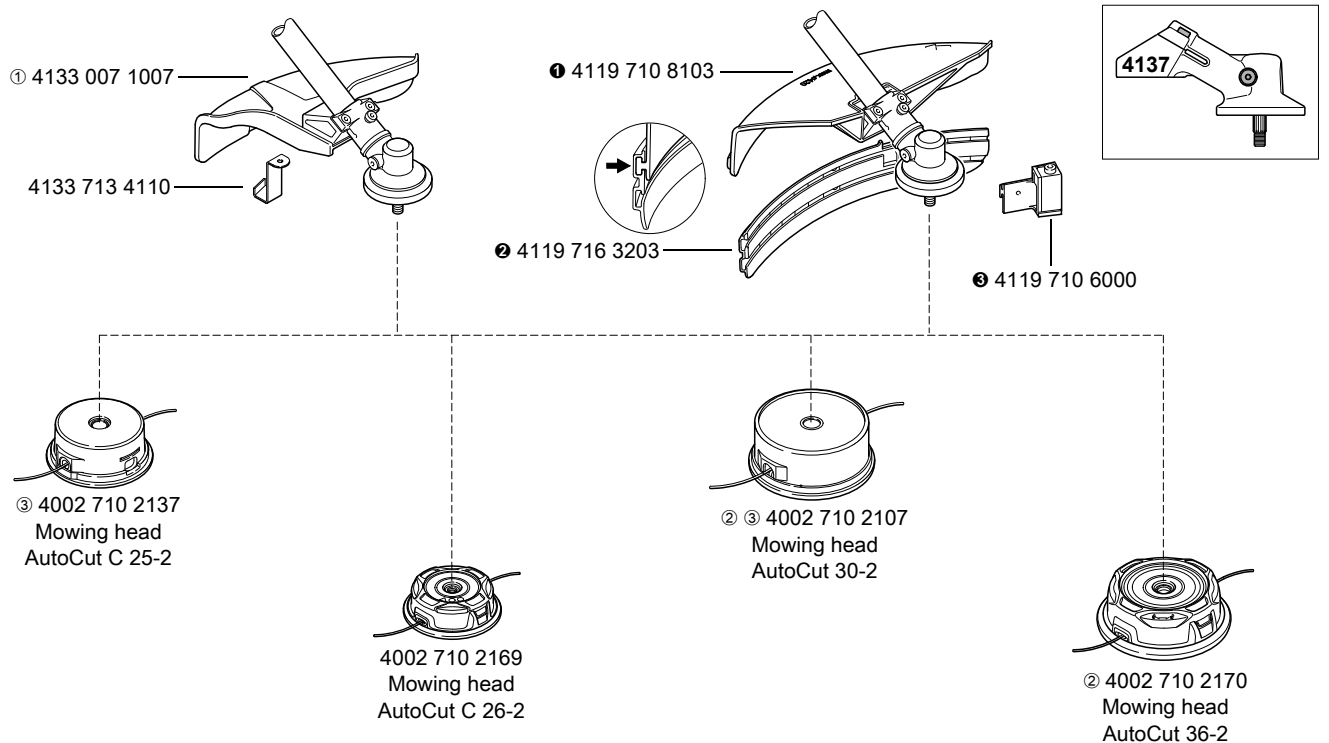

1000-GXX-3478-A0

① Approved in AUS, NZ only: 4133 007 1008

① + ② + ③ = 4119 007 1027

② Approved only for KM 130

③ No longer available

(a) up to 2015

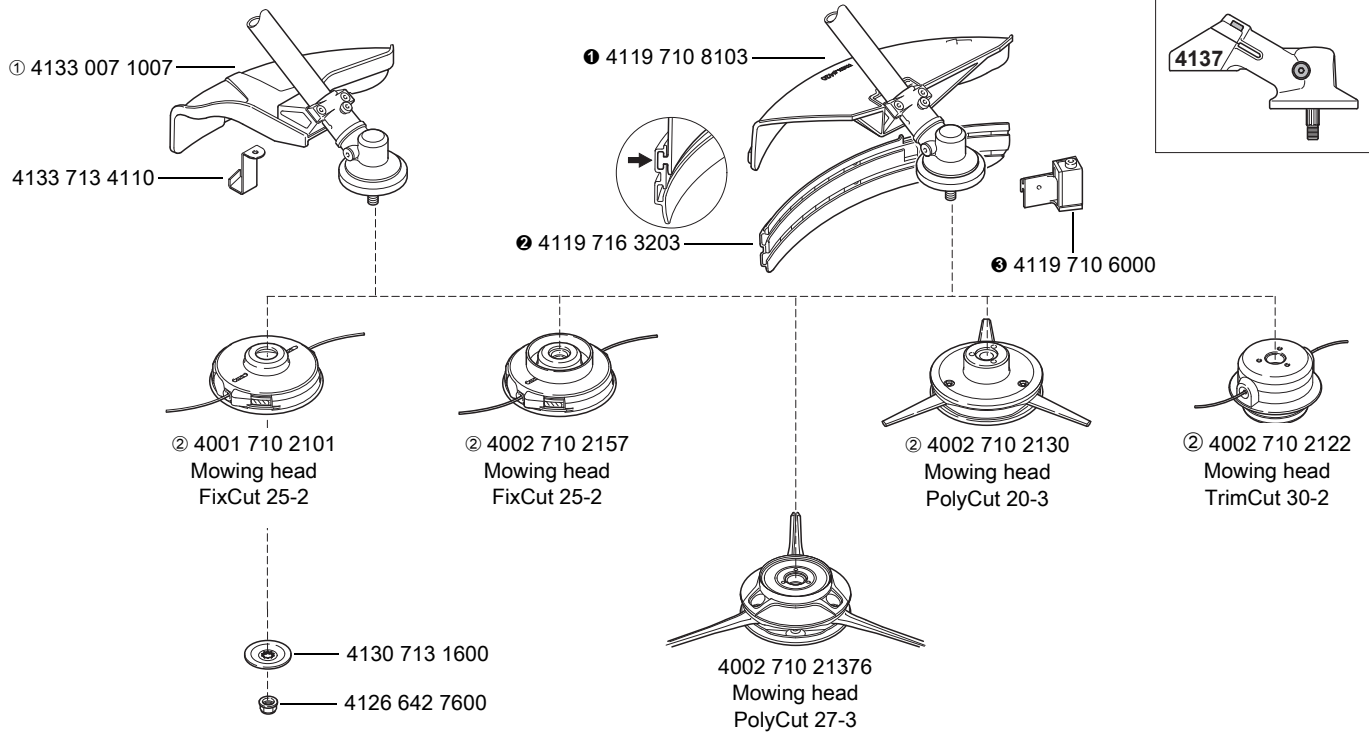

0000-GXX-5749-A1

① Approved in AUS, NZ only: 4133 007 1008

② No longer available

① + ② + ③ = 4119 007 1027

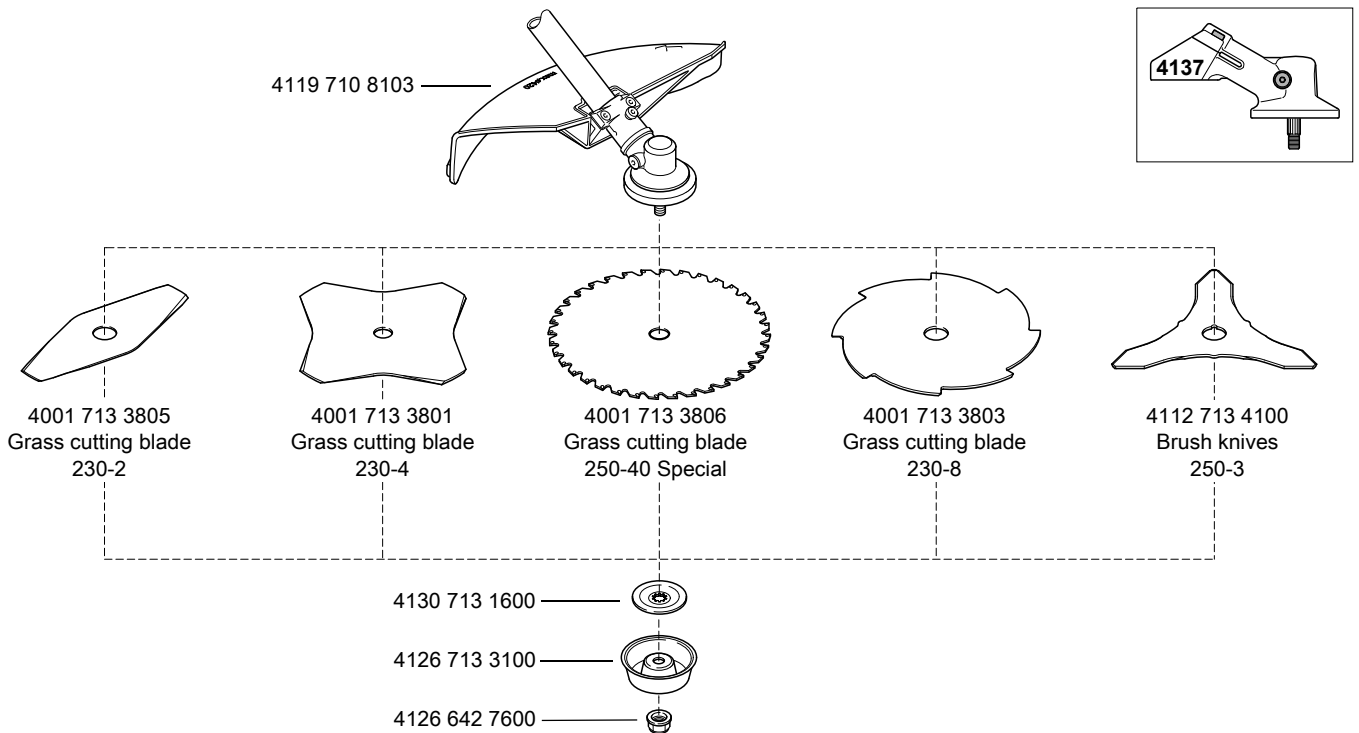

681KT918 KN

(a) up to 2015

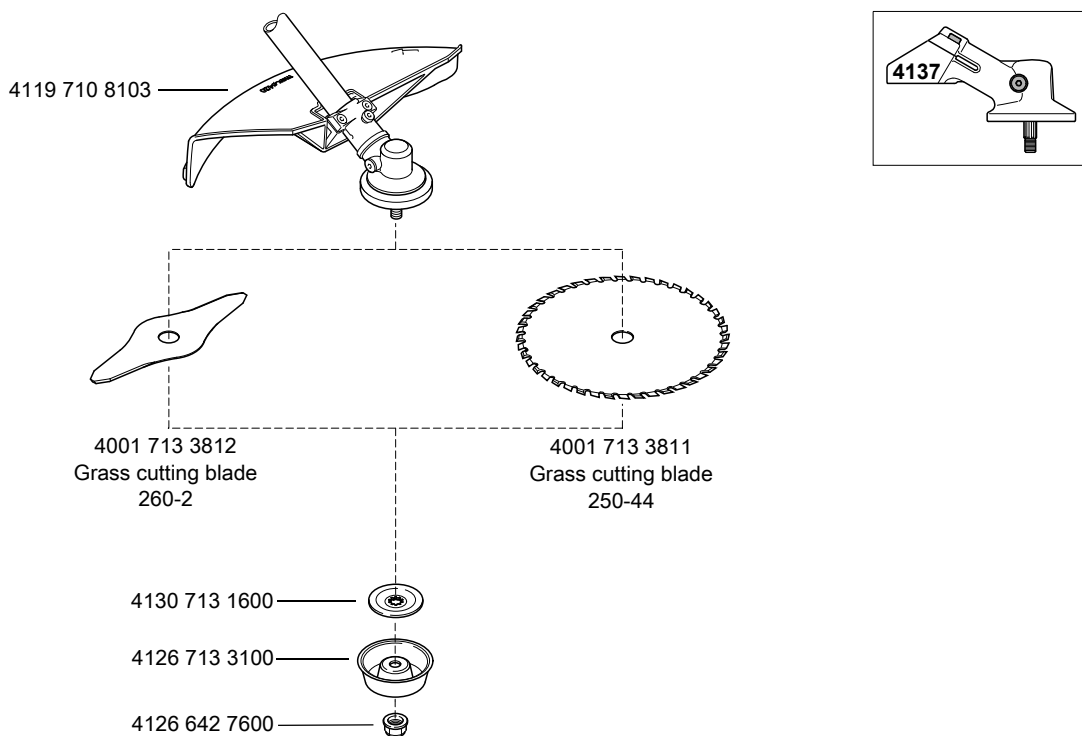

681KT1097 KN

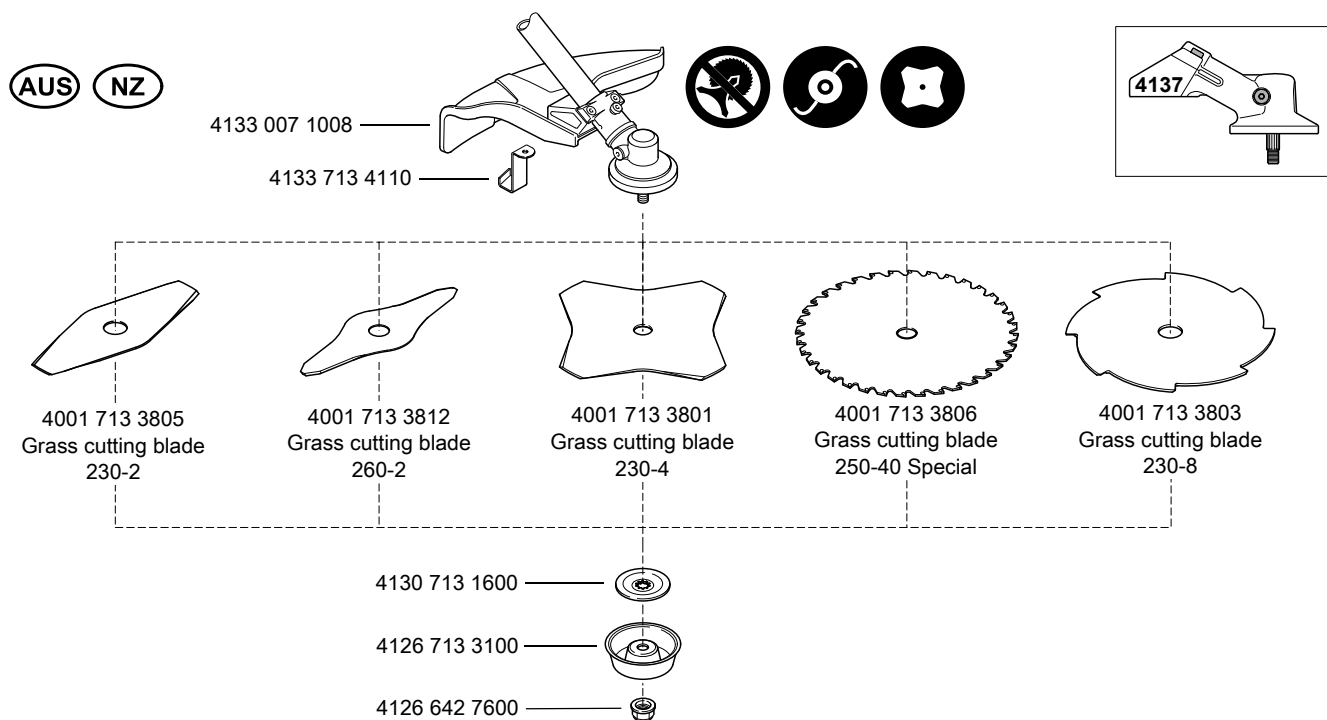

681KT1098 KN

AUS NZ

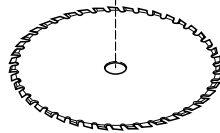
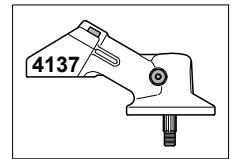
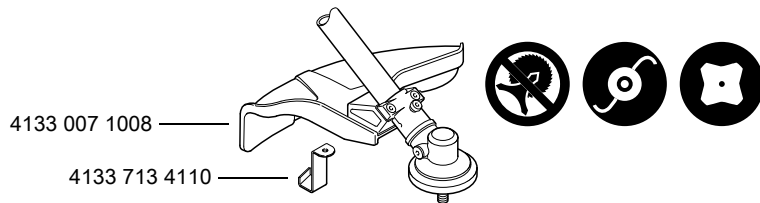

4001 713 3812
Grass cutting blade
250-44

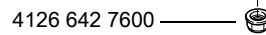
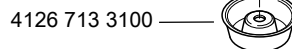
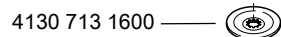

681KT1123 KN

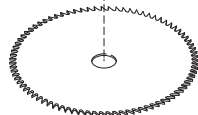
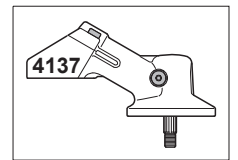
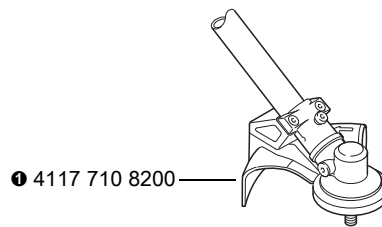

① 4112 713 4201
Circular saw blade
200-80, scratcher tooth

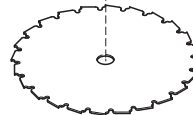

① 4112 713 4203
Circular saw blade
200-22, chisel tooth

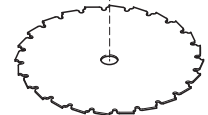

① 4001 713 4203
Circular saw blade
200-22 HP, chisel tooth

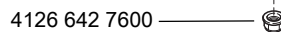
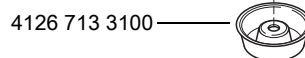
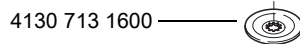

681KT920-A1

① Not approved on brushcutters with loop handle

① + Transport guard = 4126 007 1002

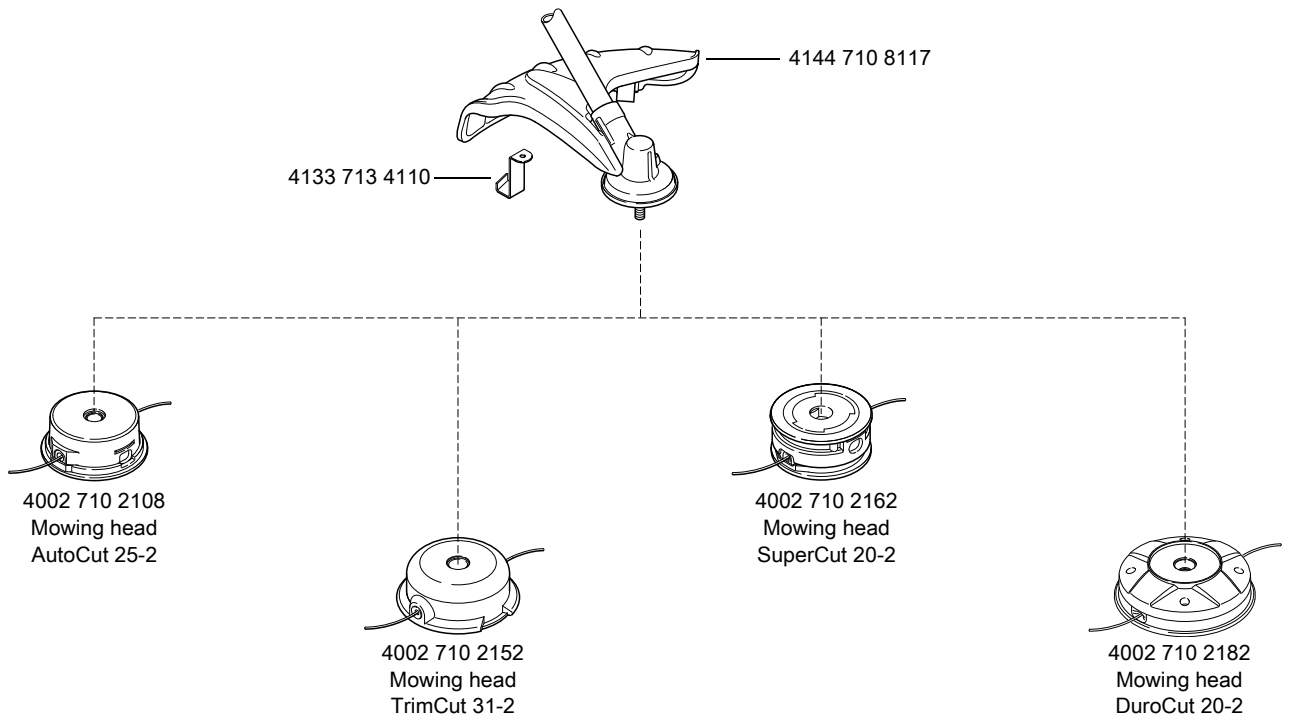

681KT933 KN

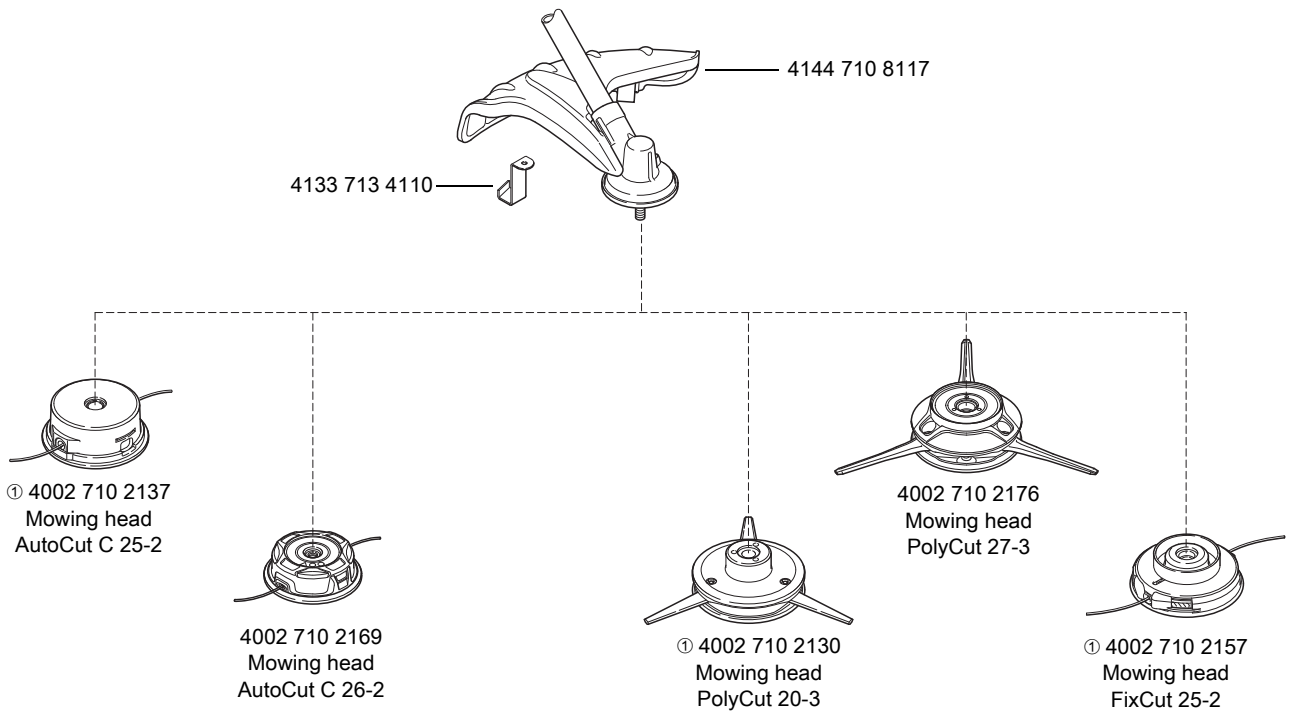

0000-GXX-5750-A0

① No longer available

Polymatic 40-2

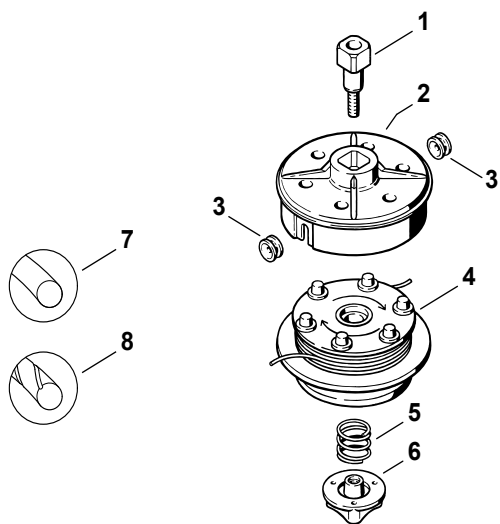

681KT682 SC

No.	Part number	Qty.	Designation
	4003 710 2100	1	Mowing head Polymatic 40-2 (C)
			□ 1 - 8
1	4003 713 6500	1	Collar screw
2	4110 713 3600	1	Spool housing
3	4110 713 8300	2	Sleeve
4	4110 713 3000	1	Spool, spool with nylon line
5	0000 997 2300	1	Helical spring, spring
6	4110 713 6801	1	Star nut l/h thread
7		2	Mowing line, round Ø 2.4 mm x 2.5 m (D)
	0000 930 2338	1	Mowing line, round Ø 2.4 mm x 14.6 m (A,B)
	0000 930 2528	1	Mowing line, round Ø 2.4 mm x 15 m (A,B)
8		2	Mowing line, round, quiet Ø 2.4 mm x 2.5 m (B)
	0000 930 2419	1	Mowing line, round, quiet Ø 2.4 mm x 14 m (A,B)

TrimCut 30-2

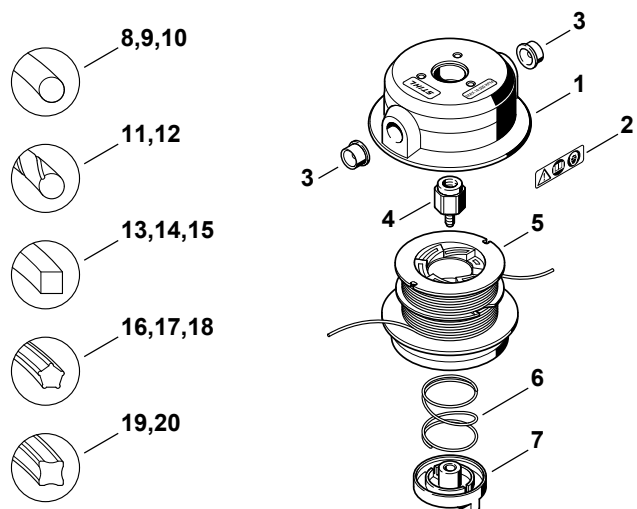

681KT67Z SC

No.	Part number	Qty.	Designation
	4002 710 2122	1	Mowing head TrimCut 30-2 (C)
			□ 1 - 7, 11
1	4002 710 3600	1	Spool housing □ 2, 3
2	0000 967 3706	1	Warning pictogram
3	4002 713 8302	2	Sleeve
4	4002 713 6502	1	Collar screw
5	4002 713 3016	1	Spool, spool with nylon line
6	0000 997 3800	1	Helical spring, spring
7	4002 740 6700	1	Star nut l/h thread
8		2	Mowing line, round Ø 2.4 mm x 3.5 m (B)
	0000 930 2338	1	Mowing line, round Ø 2.4 mm x 14.6 m (A,B)
9		2	Mowing line, round Ø 2.7 mm x 3.5 m (B)
	0000 930 2341	1	Mowing line, round Ø 2.7 mm x 9.8 m (A,B)
10		2	Mowing line, round Ø 3 mm x 2.5 m (B)
	0000 930 2344	1	Mowing line, round Ø 3 mm x 53 m (A,B)
11		2	Mowing line, round, quiet Ø 2.4 mm x 5 m
	0000 930 2419	1	Mowing line, round, quiet Ø 2.4 mm x 14 (A,B)
12		2	Mowing line, round, quiet Ø 2.7 mm x 3.5 m (B)
	0000 930 2422	1	Mowing line, round, quiet Ø 2.7 mm x 9 m (A,B)
13		2	Mowing line, square Ø 2.4 mm x 5m (A,B)
	0000 930 2640	1	Mowing line, square Ø 2.4 mm x 41 m (A,B)
14		2	Mowing line, square Ø 2.7 mm x 3.5m (B)
	0000 930 2642	1	Mowing line, square Ø 2.7 mm x 32 m (A,B)
15		2	Mowing line, square Ø 3 mm x 2.5 m (B)
	0000 930 2644	1	Mowing line, square Ø 3 mm x 53 m (A,B)
16		2	Mowing line, pentagonal Ø 2.4 mm x 8 m (B)
	0000 930 3340	1	Mowing line, pentagonal Ø 2.4 mm x 48 m (A,B)

TrimCut 30-2

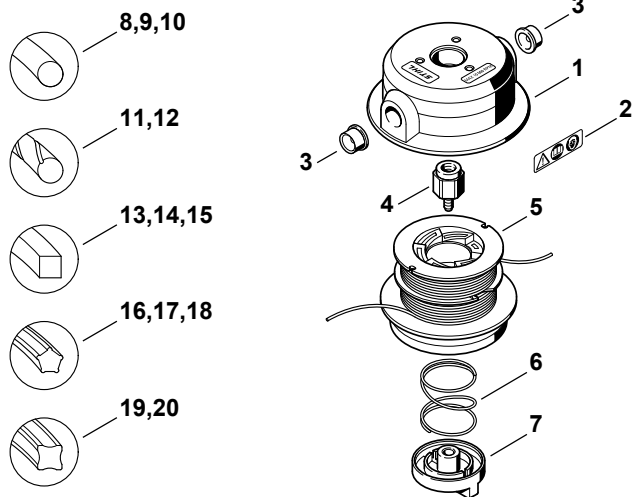

No.	Part number	Qty.	Designation
	4002 710 2122	1	Mowing head TrimCut 30-2 (C)
			□ 1 - 7, 11
17		2	Mowing line, pentagonal Ø 2.7 mm x 3.5 m (A,B)
	0000 930 3343	1	Mowing line, pentagonal Ø 2.7 mm x 77 m (A,B)
18		2	Mowing line, pentagonal Ø 3 mm x 2.5 m (A,B)
	0000 930 3344	1	Mowing line, pentagonal Ø 3 mm x 58 m (A,B)
19		2	Mowing line, X-shaped Ø 2.4 mm x 5 m (B)
	0000 930 3410	1	Mowing line, X-shaped Ø 2.4 mm x 83 m (A,B) USA
20		2	Mowing line, X-shaped Ø 2.7 mm x 3.5 m (A,B)
	0000 930 3411	1	Mowing line, X-shaped Ø 2.7 mm x 65 m (A,B) USA

TrimCut 31-2

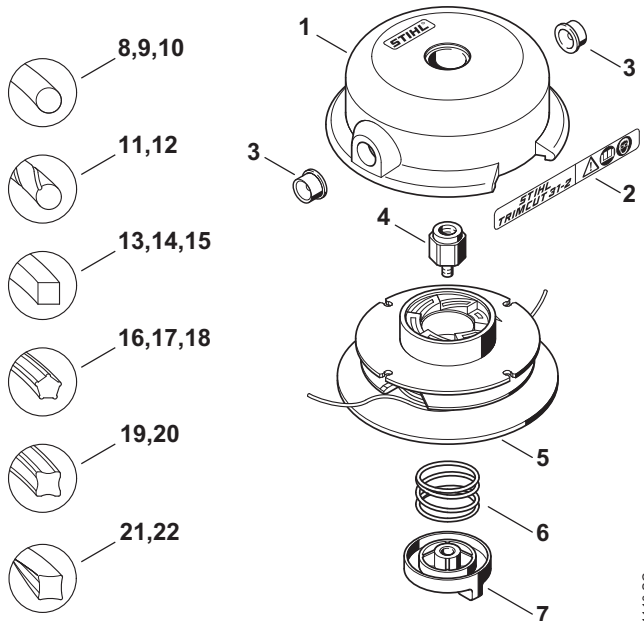

No.	Part number	Qty.	Designation
	4002 710 2152	1	Mowing head TrimCut 31-2
			□ 1 - 7
1	4002 713 3602	1	Spool housing
2	4002 967 4617	1	Instruction label
3	4002 713 8302	2	Sleeve
4	4002 713 6502	1	Collar screw
	4002 710 4314	1	Spool □ 5
5	4002 713 3004	1	Spool, spool with nylon line
6	0000 997 3800	1	Helical spring, spring
7	4002 740 6701	1	Star nut l/h thread
8	0000 930 2338	1	Mowing line, round Ø 2.4 mm x 14.6 m (B)
9	0000 930 2341	1	Mowing line, round Ø 2.7 mm x 9.8 m (B)
10	0000 930 2344	1	Mowing line, round Ø 3 mm x 53 m (B)
11	0000 930 2419	1	Mowing line, round, quiet Ø 2.4 mm x 14 m (B)

TrimCut 31-2

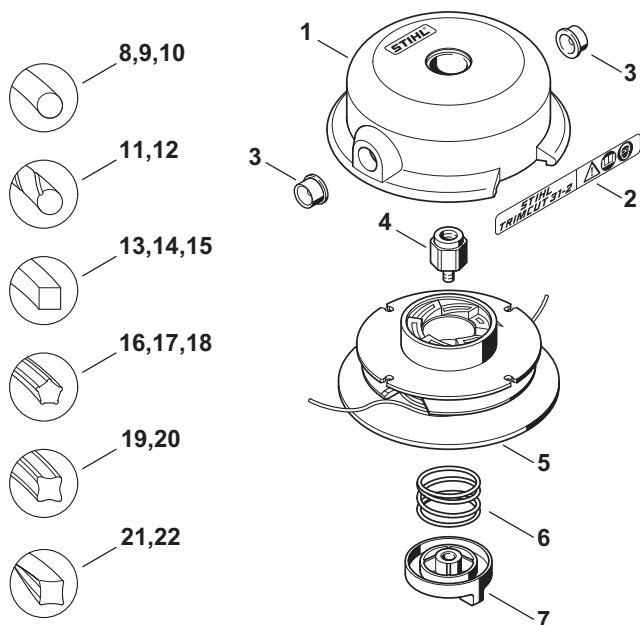

681K1110 SC

No.	Part number	Qty.	Designation
	4002 710 2152	1	Mowing head TrimCut 31-2 □ 1 - 7
12	0000 930 2422	1	Mowing line, round, quiet Ø 2.7 mm x 9 m (B)
13	0000 930 2640	1	Mowing line, square Ø 2.4 mm x 41 m (B)
14	0000 930 2642	1	Mowing line, square Ø 2.7 mm x 32 m (B)
15	0000 930 2644	1	Mowing line, square Ø 3 mm x 53 m (B)
16	0000 930 3340	1	Mowing line, pentagonal Ø 2.4 mm x 48 m (B)
17	0000 930 3343	1	Mowing line, pentagonal Ø 2.7 mm x 77 m (B)
18	0000 930 3344	1	Mowing line, pentagonal Ø 3 mm x 58 m (B)
19	0000 930 3410	1	Mowing line, X-shaped Ø 2.4 mm x 83 m (B) USA
20	0000 930 3411	1	Mowing line, X-shaped Ø 2.7 mm x 65 m (B) USA
21	0000 930 4301	1	Mowing line CF3 Pro Ø 2.7 mm x 26 m 3K (B)
22	0000 930 4302	1	Mowing line CF3 Pro Ø 3.0 mm x 21 m 3K (B)

TrimCut 40-2

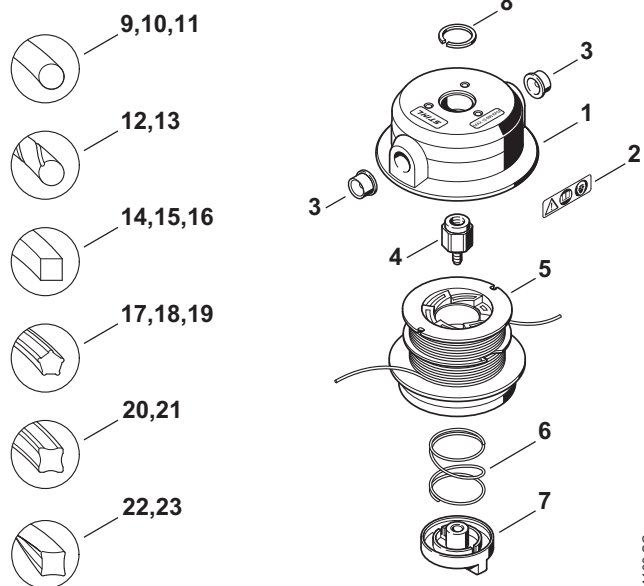

681KT1108 SC

No.	Part number	Qty.	Designation
	4003 710 2101	1	Mowing head TrimCut 40-2
			□ 1 - 8
1	4002 710 3600	1	Spool housing □ 2, 3
2	0000 967 3706	1	Warning plate Pictogram
3	4002 713 8302	2	Sleeve
4	4003 713 6501	1	Collar screw M12x1.5 l/h thread
5	4002 713 3016	1	Spool, spool with nylon line
6	0000 997 3800	1	Helical spring, spring
7	4002 740 6700	1	Star nut l/h thread
8	4111 716 9300	1	Ring
9	0000 930 2338	1	Mowing line, round Ø 2.4 mm x 14.6 m (B)
10	0000 930 2341	1	Mowing line, round Ø 2.7 mm x 9.8 m (B)
11	0000 930 2344	1	Mowing line, round Ø 3 mm x 53 m (B)
12	0000 930 2419	1	Mowing line, round, quiet Ø 2.4 mm x 14 m (B)
13	0000 930 2422	1	Mowing line, round, quiet Ø 2.7 mm x 9 m (B)
14	0000 930 2640	1	Mowing line, square Ø 2.4 mm x 41 m (B)
15	0000 930 2642	1	Mowing line, square Ø 2.7 mm x 32 m (B)
16	0000 930 2644	1	Mowing line, square Ø 3 mm x 53 m (B)
17	0000 930 3340	1	Mowing line, pentagonal Ø 2.4 mm x 48 m (B)
18	0000 930 3343	1	Mowing line, pentagonal Ø 2.7 mm x 77 m (B)
19	0000 930 3344	1	Mowing line, pentagonal Ø 3 mm x 58 m (B)
20	0000 930 3410	1	Mowing line, X-shaped Ø 2.4 mm x 83 m (B) USA
21	0000 930 3411	1	Mowing line, X-shaped Ø 2.7 mm x 65 m (B) USA
22	0000 930 4301	1	Mowing line CF3 Pro Ø 2.7 mm x 26 m 3K (B)
23	0000 930 4302	1	Mowing line CF3 Pro Ø 3.0 mm x 21 m 3K (B)

TrimCut 41-2

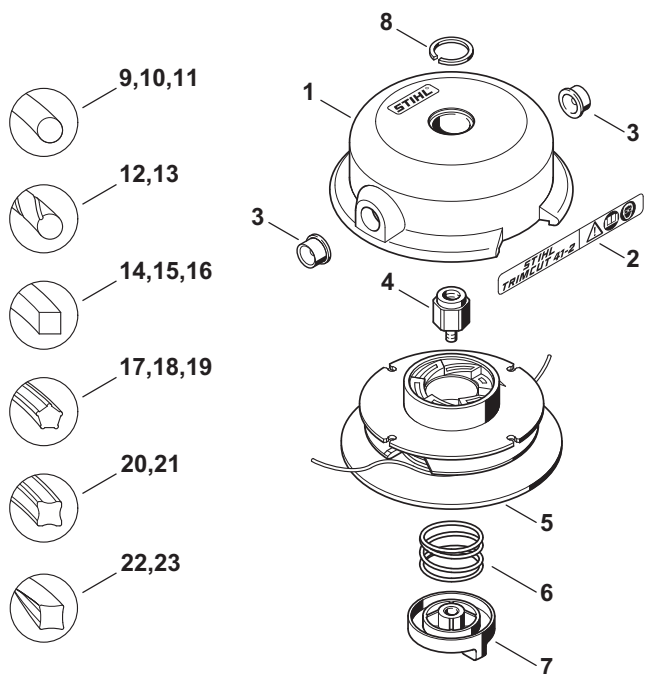

661KT1111 SC

No.	Part number	Qty.	Designation
	4003 710 2104	1	Mowing head TrimCut 41-2
			□ 1 - 8
1	4002 713 3602	1	Spool housing
2	4003 967 4607	1	Instruction label
3	4002 713 8302	2	Sleeve
4	4003 713 6501	1	Collar screw M12x1.5 l/h thread
	4003 710 4306	1	Spool □ 5
5	4002 713 3004	1	Spool, spool with nylon line
6	0000 997 3800	1	Helical spring, spring
7	4002 740 6701	1	Star nut l/h thread
8	4111 716 9300	1	Ring
9	0000 930 2338	1	Mowing line, round Ø 2.4 mm x 14.6 m (B)
10	0000 930 2341	1	Mowing line, round Ø 2.7 mm x 9.8 m (B)
11	0000 930 2344	1	Mowing line, round Ø 3 mm x 53 m (B)
12	0000 930 2419	1	Mowing line, round, quiet Ø 2.4 mm x 14 m (B)
13	0000 930 2422	1	Mowing line, round, quiet Ø 2.7 mm x 9 m (B)
14	0000 930 2640	1	Mowing line, square Ø 2.4 mm x 41 m (B)
15	0000 930 2642	1	Mowing line, square Ø 2.7 mm x 32 m (B)
16	0000 930 2644	1	Mowing line, square Ø 3 mm x 53 m (B)
17	0000 930 3340	1	Mowing line, pentagonal Ø 2.4 mm x 48 m (B)
18	0000 930 3343	1	Mowing line, pentagonal Ø 2.7 mm x 77 m (B)
19	0000 930 3344	1	Mowing line, pentagonal Ø 3 mm x 58 m (B)
20	0000 930 3410	1	Mowing line, X-shaped Ø 2.4 mm x 83 m (B)
21	0000 930 3411	1	Mowing line, X-shaped Ø 2.7 mm x 65 m (B)
22	0000 930 4301	1	Mowing line CF3 Pro Ø 2.7 mm x 26 m 3K (B)
23	0000 930 4302	1	Mowing line CF3 Pro Ø 3.0 mm x 21 m 3K (B)

TrimCut 50-2

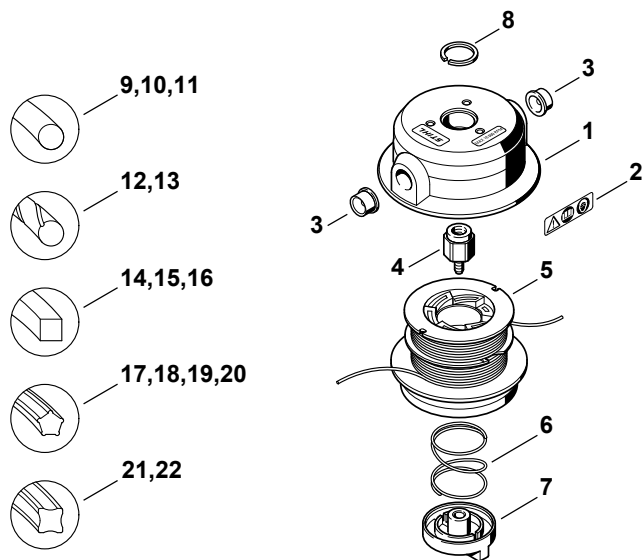

681KT676 SC

No.	Part number	Qty.	Designation
	4005 710 2110	1	Mowing head TrimCut 50-2 (C)
			□ 1 - 8, 13
1	4002 710 3600	1	Spool housing □ 2, 3
2	0000 967 3706	1	Warning plate Pictogram
3	4002 713 8302	2	Sleeve
4	4005 713 6500	1	Collar screw M14x1.5 l/h thread
5	4002 713 3016	1	Spool, spool with nylon line
6	0000 997 3800	1	Helical spring, spring
7	4002 740 6700	1	Star nut l/h thread
8	4111 716 9300	1	Ring
9		2	Mowing line, round Ø 2.4 mm x 5 m (B)
	0000 930 2338	1	Mowing line, round Ø 2.4 mm x 14.6 m (A,B)
10		2	Mowing line, round Ø 2.7 mm x 3.5 m (B)
	0000 930 2341	1	Mowing line, round Ø 2.7 mm x 9.8 m (A,B)
11		2	Mowing line, round Ø 3 mm x 2.5 m (B)
	0000 930 2344	1	Mowing line, round Ø 3 mm x 53 m (A,B)
12		2	Mowing line, round, quiet Ø 2.4 mm x 5 m (B)
	0000 930 2419	1	Mowing line, round, quiet Ø 2.4 mm x 14 m (A,B)
13		2	Mowing line, round, quiet Ø 2.7 mm x 3.5 m (D)
	0000 930 2422	1	Mowing line, round, quiet Ø 2.7 mm x 9 m (A,B)
14		2	Mowing line, square Ø 2.4 mm x 5 m (B)
	0000 930 2640	1	Mowing line, square Ø 2.4 mm x 41 m (A,B)
15		2	Mowing line, square Ø 2.7 mm x 3.5 m (B)
	0000 930 2642	1	Mowing line, square Ø 2.7 mm x 32 m (A,B)
16		2	Mowing line, square Ø 3 mm x 2.5 m (B)
	0000 930 2644	1	Mowing line, square Ø 3 mm x 53 m (A,B)
17		2	Mowing line, pentagonal Ø 2.4 mm x 8 m (B)
	0000 930 3340	1	Mowing line, pentagonal Ø 2.4 mm x 48 m (A,B)
18		2	Mowing line, pentagonal Ø 2.7 mm x 3.5 m (A,B)

TrimCut 50-2

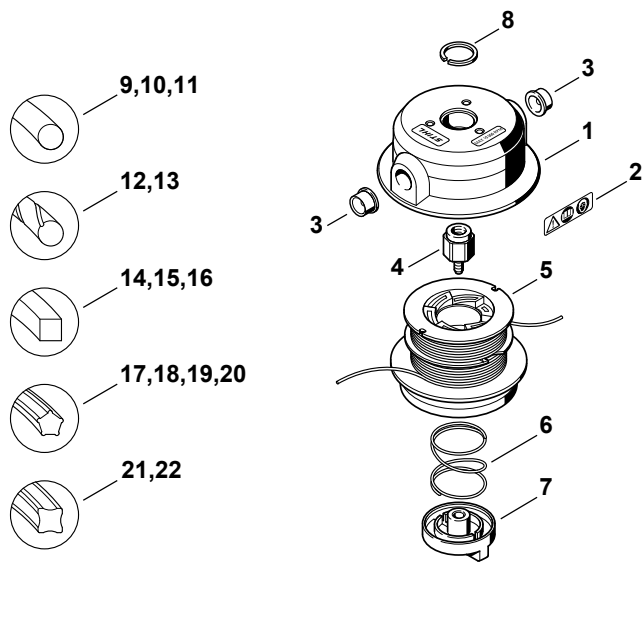

No.	Part number	Qty.	Designation
	4005 710 2110	1	Mowing head TrimCut 50-2 (C)
			□ 1 - 8, 13
	0000 930 3343	1	Mowing line, pentagonal Ø 2.7 mm x 77 m (A,B)
19		2	Mowing line, pentagonal Ø 3 mm x 2.5 m (B)
	0000 930 3344	1	Mowing line, pentagonal Ø 3 mm x 58 m (A,B)
20		1	Mowing line, pentagonal Ø 3.3 mm x 2 m (B)
	0000 930 3346	1	Mowing line, pentagonal Ø 3.3 mm x 46 m (A,B)
21		2	Mowing line, X-shaped Ø 2.4 mm x 5 m (B)
	0000 930 3410	1	Mowing line, X-shaped Ø 2.4 mm x 83 m (A,B) USA
22		2	Mowing line, X-shaped Ø 2.7 mm x 3.5 m (B)
	0000 930 3411	1	Mowing line, X-shaped Ø 2.7 mm x 65 m (A,B) USA

TrimCut 51-2

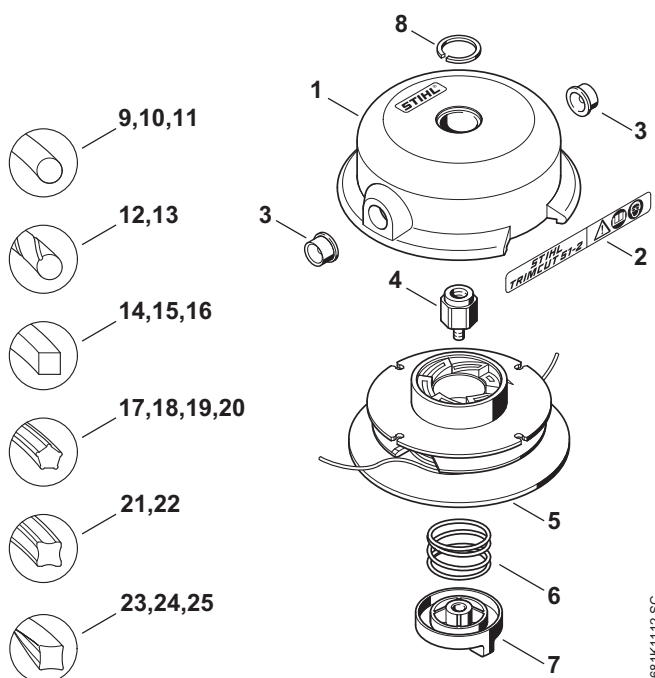

No.	Part number	Qty.	Designation
	4005 710 2103	1	Mowing head TrimCut 51-2
			□ 1 - 8
1	4002 713 3602	1	Spool housing
2	4005 967 4603	1	Instruction label
3	4002 713 8302	2	Sleeve
4	4005 713 6500	1	Collar screw M14x1.5 l/h thread
	4003 710 4306	1	Spool □ 5
5	4002 713 3004	1	Spool, spool with nylon line
6	0000 997 3800	1	Helical spring, spring
7	4002 740 6701	1	Star nut l/h thread
8	4111 716 9300	1	Ring
9	0000 930 2338	1	Mowing line, round Ø 2.4 mm x 14.6 m (B)
10	0000 930 2341	1	Mowing line, round Ø 2.7 mm x 9.8 m (B)
11	0000 930 2344	1	Mowing line, round Ø 3 mm x 53 m (B)
12	0000 930 2419	1	Mowing line, round, quiet Ø 2.4 mm x 14 m (B)

TrimCut 51-2

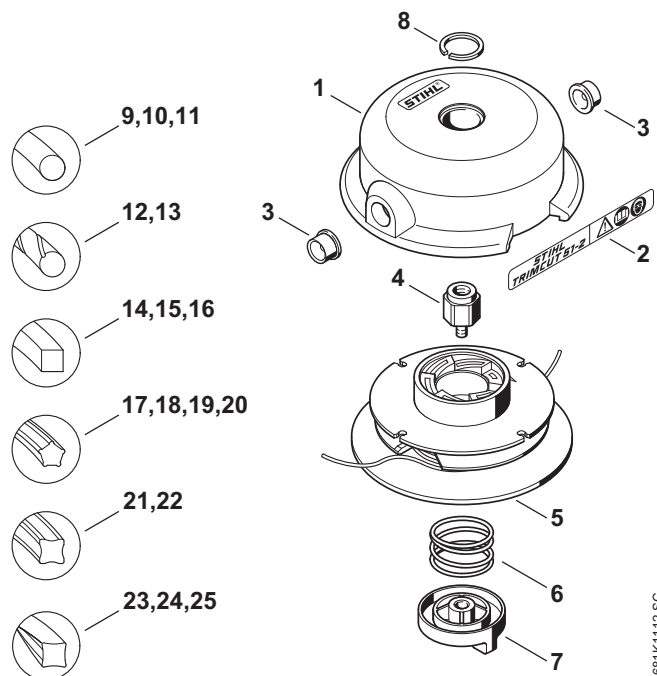

No.	Part number	Qty.	Designation
	4005 710 2103	1	Mowing head TrimCut 51-2
			□ 1 - 8
13	0000 930 2422	1	Mowing line, round, quiet Ø 2.7 mm x 9 m (B)
14	0000 930 2640	1	Mowing line, square Ø 2.4 mm x 41 m (B)
15	0000 930 2642	1	Mowing line, square Ø 2.7 mm x 32 m (B)
16	0000 930 2644	1	Mowing line, square Ø 3 mm x 53 m (B)
17	0000 930 3340	1	Mowing line, pentagonal Ø 2.4 mm x 48 m (B)
18	0000 930 3343	1	Mowing line, pentagonal Ø 2.7 mm x 77 m (B)
19	0000 930 3344	1	Mowing line, pentagonal Ø 3 mm x 58 m (B)
20	0000 930 3346	1	Mowing line, pentagonal Ø 3.3 mm x 46 m (B)
21	0000 930 3410	1	Mowing line, X-shaped Ø 2.4 mm x 83 m (B) USA
22	0000 930 3411	1	Mowing line, X-shaped Ø 2.7 mm x 65 m (B) USA
23	0000 930 4301	1	Mowing line CF3 Pro Ø 2.7 mm x 26 m 3K (B)
24	0000 930 4302	1	Mowing line CF3 Pro Ø 3.0 mm x 21 m 3K (B)
25	0000 930 4311	1	Mowing line CF3 Pro Ø 3.3 mm x 34 m 3K (B)

AutoCut 2-2

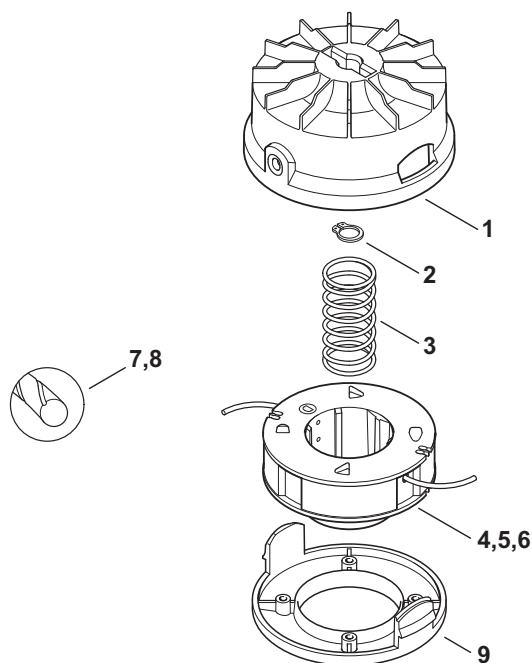

No.	Part number	Qty.	Designation
	4008 710 2100	1	Mowing head AutoCut 2-2
			□ 1 - 9
1	4008 710 3600	1	Spool housing
2	9455 621 0570	1	Circlip DIN471-8x0.8
3	6235 997 2200	1	Spring
4	4008 710 4300	1	Spool insert with line Ø 1.6 mm
5	4008 710 4301	1	Spool insert with line Ø 2.0 mm
6	4008 710 4302	1	Spool insert with line (3 pieces)
7	0000 930 2415	2	Mowing line, round, quiet Ø 1.6 mm x 19 m (D)
8	0000 930 2416	1	Mowing line, round, quiet Ø 2 mm x 14 m (A,B)
9	4008 713 7000	1	Cover

4008-GKT-0000-A0

AutoCut C 4-2

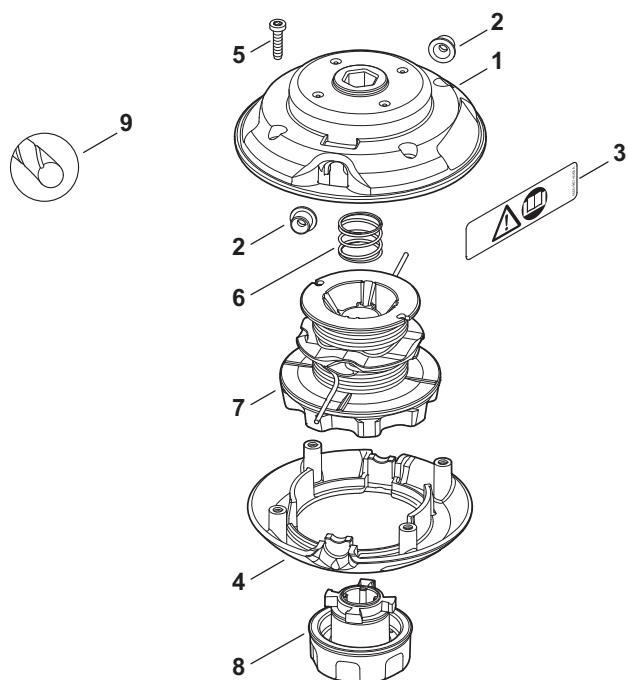

No.	Part number	Qty.	Designation
	4006 710 2121	1	Mowing head AutoCut C 4-2
			□ 1 - 6
1	4006 713 3201	1	Housing, top
2	4004 713 8300	2	Sleeve
3	0000 967 4048	1	Warning plate Pictogram
4	4006 713 3701	1	Housing, bottom
5	9074 478 3025	4	Screw IS-P4x16
6	0000 997 2015	1	Helical spring, spring
7	4006 713 3000	1	Spool, spool with nylon line
8	4006 710 4001	1	Cap
9		2	Mowing line, round, quiet Ø 2 mm x 2.5 m (D)
	0000 930 2416	1	Mowing line, round, quiet Ø 2 mm x 14 m (A,B)

681KT28 SC

AutoCut 5-2

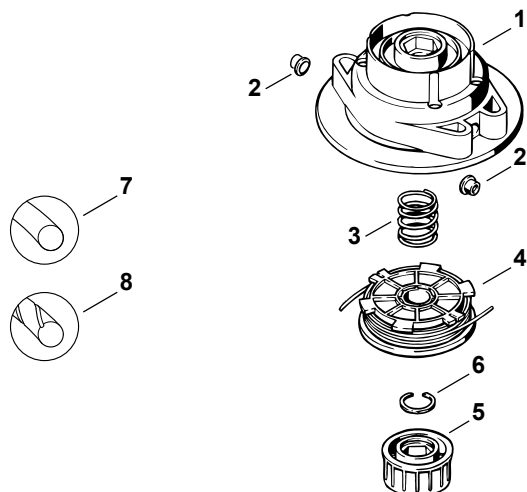

681KT549 SC

No.	Part number	Qty.	Designation
	4006 710 2100	1	Mowing head AutoCut 5-2 □ 1 - 7
1	4006 710 3600	1	Spool housing □ 2
2	4004 713 8300	2	Sleeve
3	0000 997 3100	1	Helical spring, spring
	4004 710 4300	1	Spool insert with nylon line □ 4, 7
4	4004 713 3000	1	Spool, spool with nylon line
5	4006 710 4000	1	Cap □ 6
6	9465 620 2771	1	Snap ring 22
7		2	Mowing line, round Ø 2 mm x 3 m (A,B)
	0000 930 2335	1	Mowing line, round Ø 2 mm x 14 m (A,B)
8		2	Mowing line, round, quiet Ø 2 mm x 3 m
	0000 930 2416	1	Mowing line, round, quiet Ø 2 mm x 14 m (A,B)

AutoCut C 5-2

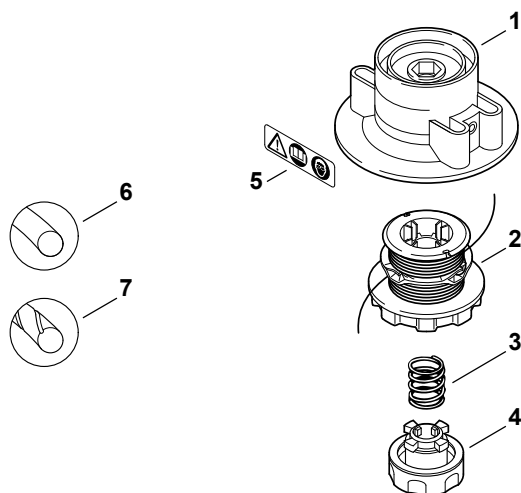

681KT547 SC

No.	Part number	Qty.	Designation
	4006 710 2105	1	Mowing head AutoCut C 5-2 □ 1 - 5, 7
1		1	Spool housing (D)
2	4006 713 3000	1	Spool, spool with nylon line
3	0000 997 2015	1	Helical spring, spring
4	4006 710 4001	1	Cap
5	0000 967 3706	1	Warning plate Pictogram
6		2	Mowing line, round Ø 2 mm x 2.5 m (B)
	0000 930 2335	1	Mowing line, round Ø 2 mm x 14 m (A,B)
7		2	Mowing line, round, quiet Ø 2 mm x 2.5 m
	0000 930 2416	1	Mowing line, round, quiet Ø 2 mm x 14 m (A,B)

AutoCut C 6-2

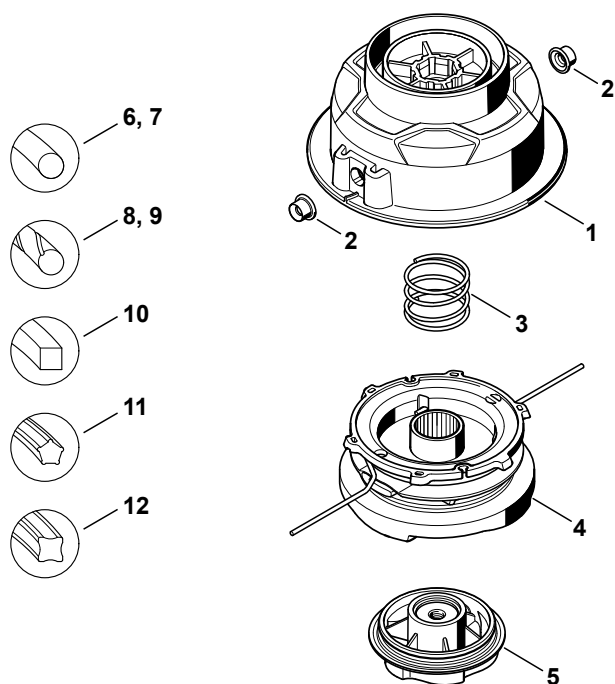

0000-GXX-2534-A0

No.	Part number	Qty.	Designation
	4006 710 2126	1	Mowing head AutoCut C 6-2
			□ 1, 3 - 5
1	4006 710 3602	1	Spool housing
2	4006 713 8302	2	Sleeve
3	4006 997 3100	1	Helical spring, spring
4	4006 820 1500	1	Spool, spool with nylon line
5	4006 710 4003	1	Cap
6	0000 930 2335	1	Mowing line, round Ø 2 mm x 14 m (A,B)
7		1	Mowing line, round Ø 2.4 mm x 4 m
	0000 930 2338	1	Mowing line, round Ø 2.4 mm x 14.6 m (A,B)
8		1	Mowing line, round, quiet Ø 2 mm x 4 m
	0000 930 2416	1	Mowing line, round, quiet Ø 2 mm x 14 m (A,B)
9		1	Mowing line, round, quiet Ø 2.4 mm x 4 m
	0000 930 2419	1	Mowing line, round, quiet Ø 2.4 mm x 14 m (A,B)
10		1	Mowing line, square Ø 2.4 mm x 4 m
	0000 930 2640	1	Mowing line, square Ø 2.4 mm x 41 m (B)
11		1	Mowing line, pentagonal Ø 2.4 mm x 4 m
	0000 930 3340	1	Mowing line, pentagonal Ø 2.4 mm x 48 m (B)
12		1	Mowing line, X-shaped Ø 2.4 mm x 4 m
	0000 930 3410	1	Mowing line, X-shaped Ø 2.4 mm x 83 m (B)

AutoCut 11-2

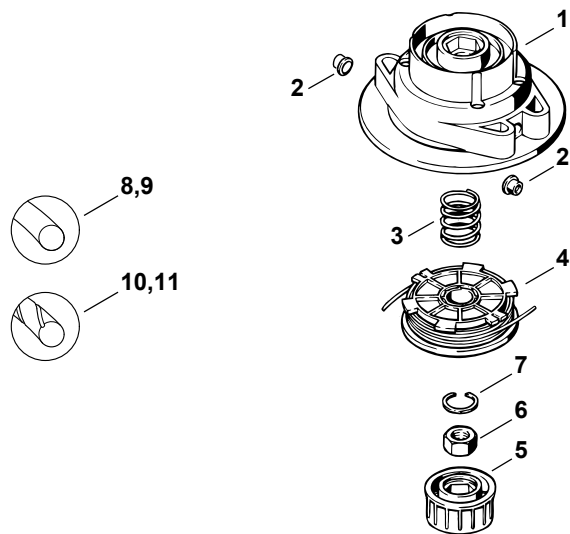

681KT588 SC

No.	Part number	Qty.	Designation
	4004 710 2105	1	Mowing head AutoCut 11-2
			□ 1 - 7, 10
1	4004 710 3600	1	Spool housing □ 2
2	4004 713 8300	2	Sleeve
3	0000 997 2100	1	Helical spring, spring
	4004 710 4304	1	Spool with nylon line □ 4, 10
4	4004 713 3000	1	Spool, spool with nylon line
5	4004 710 4000	1	Cap □ 6, 7
6	9210 260 1400	1	Nut DIN934-M12-8
7	9465 620 2771	1	Snap ring 22
8		2	Mowing line, round Ø 2 mm x 3 m (B)
	0000 930 2335	1	Mowing line, round Ø 2 mm x 14 m (A,B)
9		2	Mowing line, round Ø 2.4 mm x 2.5 m (B)
	0000 930 2338	1	Mowing line, round Ø 2.4 mm x 14.6 m (A,B)
10		2	Mowing line, round, quiet Ø 2 mm x 3 m
	0000 930 2416	1	Mowing line, round, quiet Ø 2 mm x 14 m (A,B)
11		2	Mowing line, round, quiet Ø 2.4 mm x 2.5 m (B)
	0000 930 2419	1	Mowing line, round, quiet Ø 2.4 mm x 14 m (A,B)

AutoCut 21-2

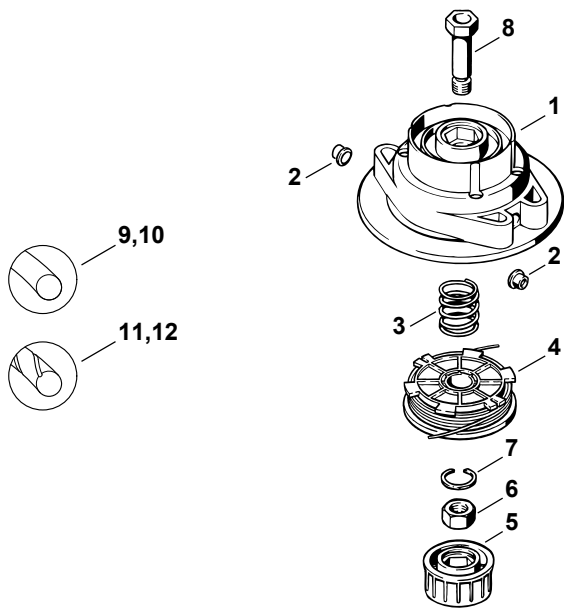

681KT590 SC

No.	Part number	Qty.	Designation
	4002 710 2113	1	Mowing head AutoCut 21-2 (C)
			□ 1 - 8, 10
1	4004 710 3600	1	Spool housing 2
2	4004 713 8300	2	Sleeve
3	0000 997 2100	1	Helical spring, spring
	4002 710 4307	1	Spool with nylon line □ 4, 10
4	4002 713 3007	1	Spool, spool with nylon line
5	4002 710 4000	1	Cap □ 6, 7
6	9210 260 1410	1	Nut DIN934-M12LH-8
7	9465 620 2771	1	Snap ring 22
8	4002 713 6501	1	Collar screw
9		2	Mowing line, round Ø 2 mm x 3 m (B)
	0000 930 2335	1	Mowing line, round Ø 2 mm x 14 m (A,B)
10		2	Mowing line, round Ø 2.4 mm x 2.5 m (D)
	0000 930 2338	1	Mowing line, round Ø 2.4 mm x 14.6 m (A,B)
11		2	Mowing line, round, quiet Ø 2 mm x 3 m (B)
	0000 930 2416	1	Mowing line, round, quiet Ø 2 mm x 14 m (A,B)
12		2	Mowing line, round, quiet Ø 2.4 mm x 2.5 m (B)
	0000 930 2419	1	Mowing line, round, quiet Ø 2.4 mm x 14 m (A,B)

AutoCut 25-2

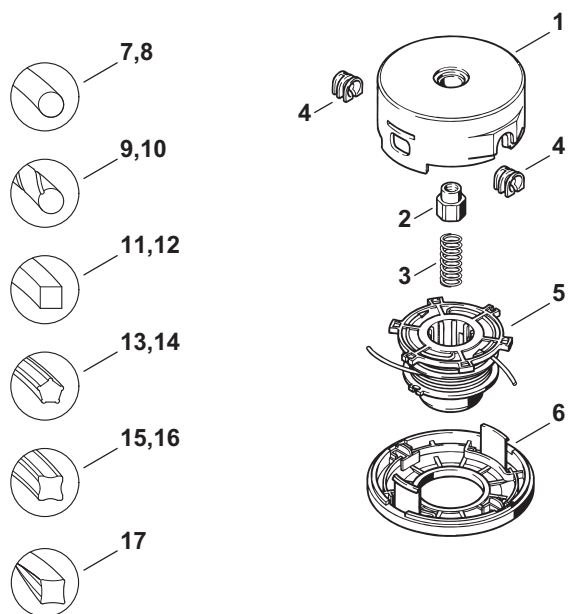

681KT1105.SC

No.	Part number	Qty.	Designation
	4002 710 2108	1	Mowing head AutoCut 25-2 □ 1 - 6
1	4002 713 9608	1	Top part
2	4002 713 6801	1	Collar nut M10x1 l/h thread
3	0000 997 1501	1	Adjusting spring, helical spring
4	4003 713 8301	2	Sleeve
	4002 710 4313	1	Spool with nylon line □ 5
5	4002 713 3017	1	Spool, spool with nylon line
6	4002 713 9708	1	Bottom part
7	0000 930 2338	1	Mowing line, round Ø 2.4 mm x 14.6 m (B)
8	0000 930 2341	1	Mowing line, round Ø 2.7 mm x 9.8 m (B)
9	0000 930 2419	1	Mowing line, round, quiet Ø 2.4 mm x 14 m (B)
10	0000 930 2422	1	Mowing line, round, quiet Ø 2.7 mm x 9 m (B)
11	0000 930 2640	1	Mowing line, square Ø 2.4 mm x 41 m (B)
12	0000 930 2642	1	Mowing line, square Ø 2.7 mm x 32 m (B)
13	0000 930 3340	1	Mowing line, pentagonal Ø 2.4 mm x 48 m (B)
14	0000 930 3343	1	Mowing line, pentagonal Ø 2.7 mm x 77 m (B)
15	0000 930 3410	1	Mowing line, X-shaped Ø 2.4 mm x 83 m (B)
16	0000 930 3411	1	Mowing line, X-shaped Ø 2.7 mm x 65 m (B)
17	0000 930 4301	1	Mowing line CF3 Pro Ø 2.7 mm x 26 m 3K (B)

AutoCut C 25-2

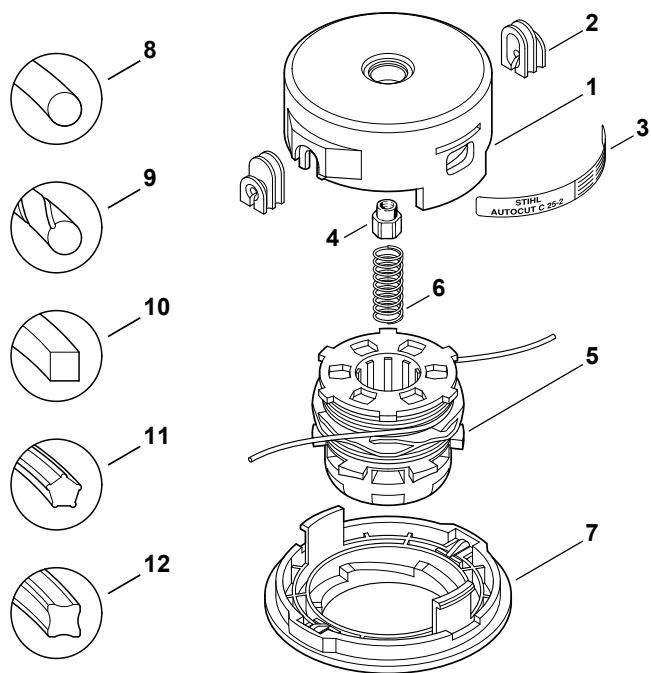

No.	Part number	Qty.	Designation
	4002 710 2137	1	Mowing head AutoCut C 25-2
			□ 1 - 7, 9
1	4002 713 9601	1	Top part
2	4002 713 8301	2	Sleeve
3	4002 967 4608	1	Instruction label
4	4002 713 6801	1	Collar nut M10x1 l/h thread
	4002 710 4301	1	Spool with nylon line □ 5, 9
5	4002 713 3003	1	Spool, spool with nylon line
6	0000 997 1501	1	Adjusting spring, helical spring
7	4002 713 9701	1	Bottom part
8		2	Mowing line, round Ø 2.4 mm x 4 m (B)
	0000 930 2338	1	Mowing line, round Ø 2.4 mm x 14.6 m (A,B)
9		2	Mowing line, round, quiet Ø 2.4 mm x 4 m
	0000 930 2419	1	Mowing line, round, quiet Ø 2.4 mm x 14 m (A,B)
10		2	Mowing line, square Ø 2.4 mm x 4 m (B)
	0000 930 2640	1	Mowing line, square Ø 2.4 mm x 41 m (A,B)
11		2	Mowing line, pentagonal Ø 2.4 mm x 4 m (B)
	0000 930 3340	1	Mowing line, pentagonal Ø 2.4 mm x 48 m (A,B)
12		2	Mowing line, X-shaped Ø 2.4 mm x 4 m (B)
	0000 930 3410	1	Mowing line, X-shaped Ø 2.4 mm x 83 m (A,B) USA

AutoCut C 26-2

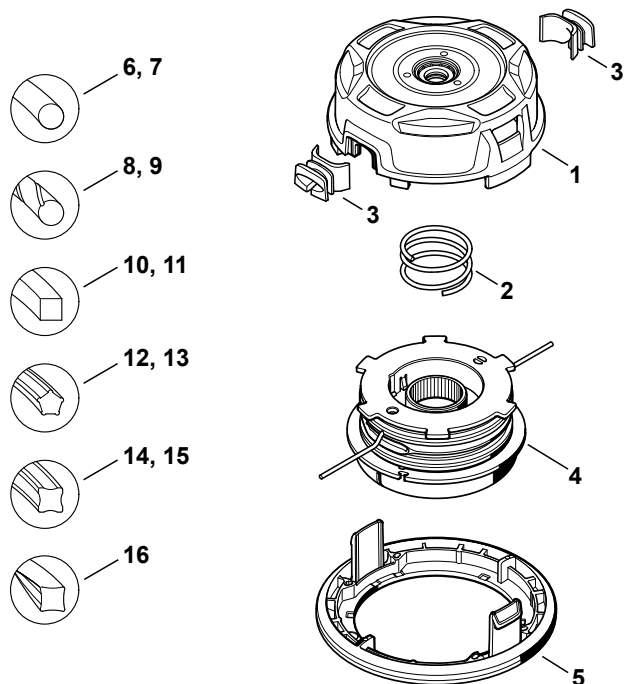

0000-GXX-2535-A0

No.	Part number	Qty.	Designation
	4002 710 2169	1	Mowing head AutoCut C 26-2
			□ 1 - 5
1	4002 710 9603	1	Top part
2	0000 997 0606	1	Adjusting spring, helical spring
3	4002 713 8306	2	Sleeve
4	4002 740 6900	1	Spool insert with cap
5	4002 713 9704	1	Bottom part
6		1	Mowing line, round Ø 2.4 mm x 4 m
	0000 930 2338	1	Mowing line, round Ø 2.4 mm x 14 m (B)
7		1	Mowing line, round Ø 2.7 mm x 7 m
	0000 930 2341	1	Mowing line, round Ø 2.7 mm x 9 m (B)
8		1	Mowing line, round, quiet Ø 2.4 mm x 8 m
	0000 930 2419	1	Mowing line, round, quiet Ø 2.4 mm x 14 m (B)
9		1	Mowing line, round, quiet Ø 2.7 mm x 7 m
	0000 930 2422	1	Mowing line, round, quiet Ø 2.7 mm x 9 m (B)
10		1	Mowing line, square Ø 2.4 mm x 8 m
	0000 930 2640	1	Mowing line, square Ø 2.4 mm x 41 m (B)
11		1	Mowing line, square Ø 2.7 mm x 7 m
	0000 930 2642	1	Mowing line, square Ø 2.7 mm x 32 m (B)
12		1	Mowing line, pentagonal Ø 2.4 mm x 8 m
	0000 930 3340	1	Mowing line, pentagonal Ø 2.4 mm x 48 m (B)
13		1	Mowing line, pentagonal Ø 2.7 mm x 7 m
	0000 930 3343	1	Mowing line, pentagonal Ø 2.7 mm x 77 m (B)
14		1	Mowing line, X-shaped Ø 2.4 mm x 8 m
	0000 930 3410	1	Mowing line, X-shaped Ø 2.4 mm x 83 m (B)
15		1	Mowing line, X-shaped Ø 2.7 mm x 7 m
	0000 930 3411	1	Mowing line, X-shaped Ø 2.7 mm x 65 m (B)
16		1	Mowing line CF3 Pro Ø 2.7 mm x 7 m 3K
	0000 930 4301	1	Mowing line CF3 Pro Ø 2.7 mm x 26 m 3K (B)

AutoCut 30-2

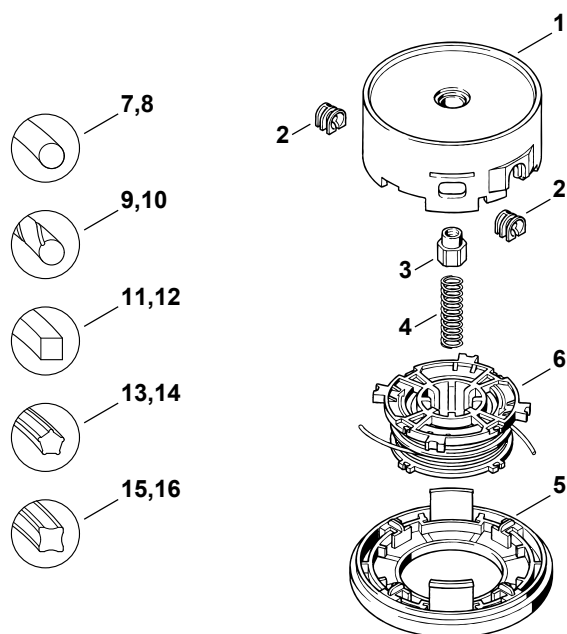

681KT592 SC

No.	Part number	Qty.	Designation
	4002 710 2107	1	Mowing head AutoCut 30-2
			□ 1 - 6
1	4003 713 9605	1	Top part
2	4003 713 8301	2	Sleeve
3	4002 713 6801	1	Collar nut M10x11/h thread
4	0000 997 1601	1	Helical spring, spring
5	4003 713 9705	1	Bottom part
	4003 710 4303	1	Spool insert with nylon line □ 6
6	4003 713 3011	1	Spool, spool with nylon line
7	0000 930 2338	1	Mowing line, round Ø 2.4 mm x 14 m (B)
8	0000 930 2341	1	Mowing line, round Ø 2.7 mm x 9 m (B)
9	0000 930 2419	1	Mowing line, round, quiet Ø 2.4 mm x 14 m (B)
10	0000 930 2422	1	Mowing line, round, quiet Ø 2.7 mm x 9 m (B)
11	0000 930 2640	1	Mowing line, square Ø 2.4 mm x 41 m (B)
12	0000 930 2642	1	Mowing line, square Ø 2.7 mm x 32 m (B)
13	0000 930 3340	1	Mowing line, pentagonal Ø 2.4 mm x 48 m (B)
14	0000 930 3343	1	Mowing line, pentagonal Ø 2.7 mm x 77 m (B)
15	0000 930 3410	1	Mowing line, X-shaped Ø 2.4 mm x 83 m (B)
16	0000 930 3411	1	Mowing line, X-shaped Ø 2.7 mm x 65 m (B)
17	0000 930 4301	1	Mowing line CF3 Pro Ø 2.7 mm x 26 m 3K (B)

AutoCut 36-2

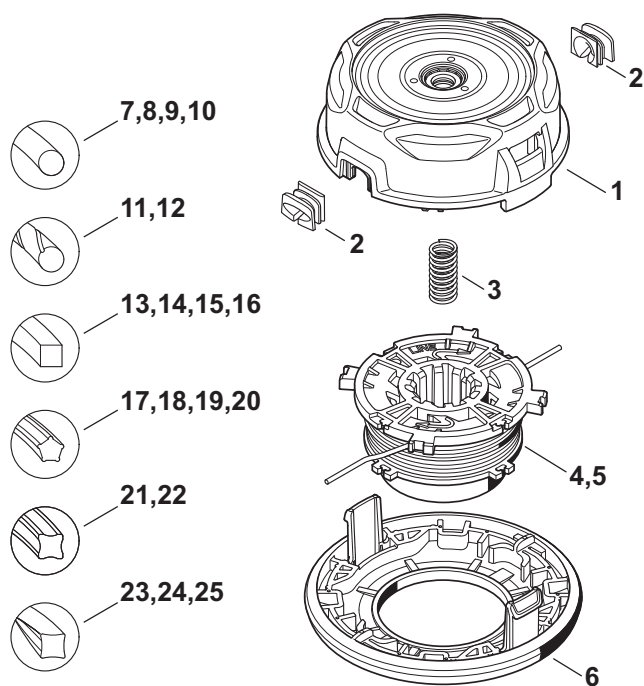

681KTT049 SC

No.	Part number	Qty.	Designation
	4002 710 2170	1	Mowing head AutoCut 36-2 □ 1 - 4, 6
1	4002 710 9604	1	Top part
2	4002 713 8307	2	Sleeve
3	0000 997 3102	1	Helical spring, spring
4	4003 710 4307	1	Spool with nylon line □ 5
5	4003 713 3001	1	Spool, spool with nylon line
6	4002 713 9706	1	Bottom part
7		2	Mowing line, round Ø 2.4 mm x 7.5 m
	0000 930 2338	1	Mowing line, round Ø 2.4 mm x 14.6 m (B)
8		2	Mowing line, round Ø 2.7 mm x 6 m
	0000 930 2341	1	Mowing line, round Ø 2.7 mm x 9 m (B)
9		2	Mowing line, round Ø 3 mm x 5 m
	0000 930 2344	1	Mowing line, round Ø 3 mm x 53 m (B)
10		2	Mowing line, round Ø 3.3 mm x 4 m
	0000 930 2345	1	Mowing line, round Ø 3.3 mm x 6 m (B)
11		2	Mowing line, round, quiet Ø 2.4 mm x 7.5 m
	0000 930 2419	1	Mowing line, round, quiet Ø 2.4 mm x 14 m (B)
12		2	Mowing line, round, quiet Ø 2.7 mm x 6 m
	0000 930 2422	1	Mowing line, round, quiet Ø 2.7 mm x 9 m (B)
13		2	Mowing line, square Ø 2.4 mm x 7.5 m
	0000 930 2640	1	Mowing line, square Ø 2.4 mm x 41 m (B)
14		2	Mowing line, square Ø 2.7 mm x 6 m (B)
	0000 930 2642	1	Mowing line, square Ø 2.7 mm x 32 m (B)
15		2	Mowing line, square Ø 3 mm x 5 m
	0000 930 2644	1	Mowing line, square Ø 3 mm x 53 m (B)
16		2	Mowing line, square Ø 3.3 mm x 4 m
	0000 930 2645	1	Mowing line, square Ø 3.3 mm x 4 m

AutoCut 36-2

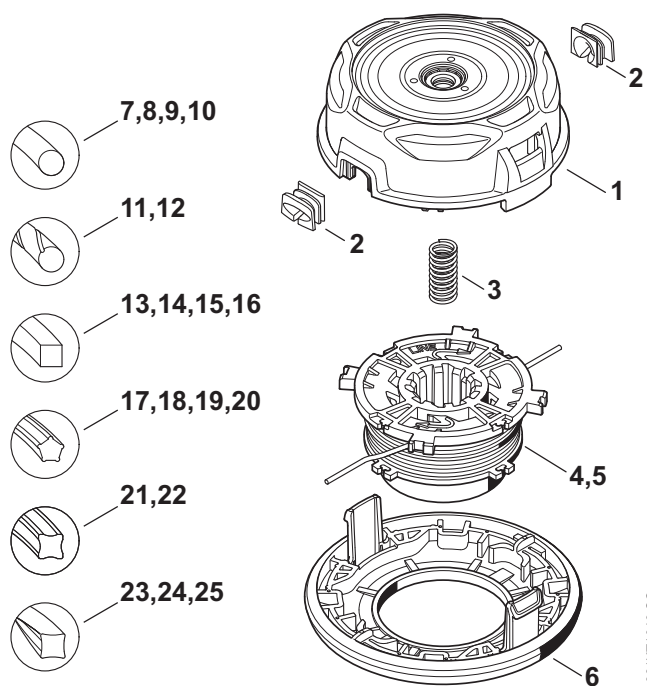

No.	Part number	Qty.	Designation
	4002 710 2170	1	Mowing head AutoCut 36-2
			□ 1 - 4, 6
17		2	Mowing line, pentagonal Ø 2.4 mm x 7.5 m
	0000 930 3340	1	Mowing line, pentagonal Ø 2.4 mm x 48 m (B)
18		2	Mowing line, pentagonal Ø 2.7 mm x 6 m
	0000 930 3343	1	Mowing line, pentagonal Ø 2.7 mm x 77 m (B)
19		2	Mowing line, pentagonal Ø 3 mm x 5 m
	0000 930 3344	1	Mowing line, pentagonal Ø 3 mm x 58 m (B)
20		2	Mowing line, pentagonal Ø 3.3 mm x 4 m
	0000 930 3345	1	Mowing line, pentagonal Ø 3.3 mm x 23 m (B)
21		2	Mowing line, X-shaped Ø 2.4 mm x 7.5 m
	0000 930 3410	1	Mowing line, X-shaped Ø 2.4 mm x 83 m (B)
22		2	Mowing line, X-shaped Ø 2.7 mm x 6 m
	0000 930 3411	1	Mowing line, X-shaped Ø 2.7 mm x 65 m (B)
23		2	Mowing line CF3 Pro Ø 2.7 mm x 6 m
	0000 930 4301	1	Mowing line CF3 Pro Ø 2.7 mm x 26 m 3K (B)
24		2	Mowing line CF3 Pro Ø 3.0 mm x 5 m
	0000 930 4302	1	Mowing line CF3 Pro Ø 3.0 mm x 21 m 3K (B)
25		2	Mowing line CF3 Pro Ø 3.3 mm x 4 m
	0000 930 4311	1	Mowing line CF3 Pro Ø 3.3 mm x 34 m 3K (B)

AutoCut40-2

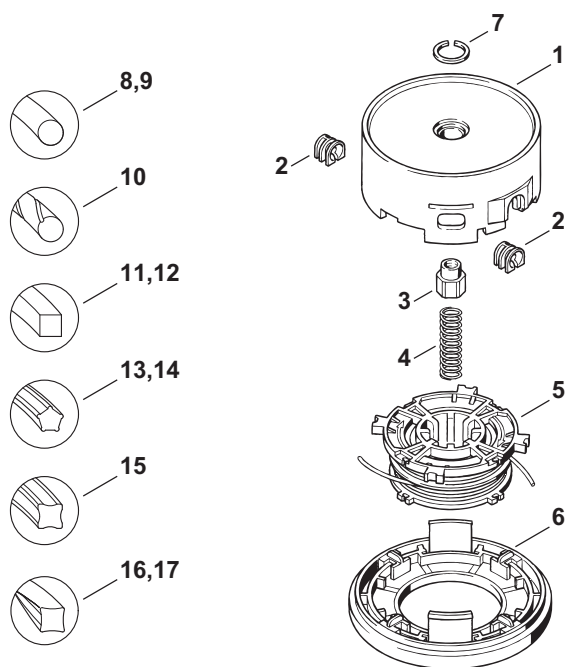

681KT1107 SC

No.	Part number	Qty.	Designation
	4003 710 2125	1	Mowing head AutoCut 40-2 □ 1 - 7
1	4003 713 9605	1	Top part
2	4003 713 8301	2	Sleeve
3	4003 713 6800	1	Collar nut M12x1.5 l/h thread
4	0000 997 1601	1	Helical spring, spring
	4003 710 4303	1	Spool with nylon line □ 5
5	4003 713 3011	1	Spool, spool with nylon line
6	4003 713 9705	1	Bottom part
7	4111 716 9300	1	Ring
8	0000 930 2341	1	Mowing line, round Ø 2.7 mm x 9 m (B)
9	0000 930 2344	1	Mowing line, round Ø 3 mm x 53 m (B)
10	0000 930 2422	1	Mowing line, round, quiet Ø 2.7 mm x 9 m (B)
11	0000 930 2642	1	Mowing line, square Ø 2.7 mm x 32 m (B)
12	0000 930 2644	1	Mowing line, square Ø 3 mm x 53 m (B)
13	0000 930 3343	1	Mowing line, pentagonal Ø 2.7 mm x 77 m (B)
14	0000 930 3344	1	Mowing line, pentagonal Ø 3 mm x 58 m (B)
15	0000 930 3411	1	Mowing line, X-shaped Ø 2.7 mm x 65 m (B)
16	0000 930 4301	1	Mowing line CF3 Pro Ø 2.7 mm x 26 m 3K (B)
17	0000 930 4302	1	Mowing line CF3 Pro Ø 3.0 mm x 21 m 3K (B)

AutoCut 46-2

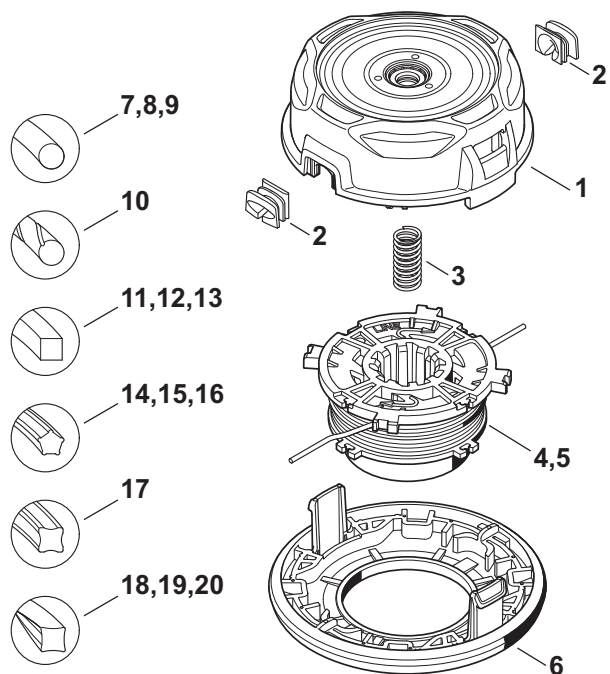

681KT1050 SC

No.	Part number	Qty.	Designation
	4003 710 2115	1	Mowing head AutoCut 46-2
			□ 1 - 4, 6
1	4003 710 9601	1	Top part
2	4002 713 8307	2	Sleeve
3	0000 997 3102	1	Helical spring, spring
4	4003 710 4307	1	Spool with nylon line □ 5
5	4003 713 3001	1	Spool, spool with nylon line
6	4003 713 9701	1	Bottom part
7		2	Mowing line, round Ø 2.7 mm x 6 m
	0000 930 2341	1	Mowing line, round Ø 2.7 mm x 9 m (B)
8		2	Mowing line, round Ø 3 mm x 5 m
	0000 930 2344	1	Mowing line, round Ø 3 mm x 53 m (B)
9		2	Mowing line, round Ø 3.3 mm x 4 m (B)
	0000 930 2345	1	Mowing line, round Ø 3.3 mm x 6 m (B)
10		2	Mowing line, round, quiet Ø 2.7 mm x 6 m
	0000 930 2422	1	Mowing line, round, quiet Ø 2.7 mm x 9 m (B)
11		2	Mowing line, square Ø 2.7 mm x 6 m
	0000 930 2642	1	Mowing line, square Ø 2.7 mm x 32 m (B)
12		2	Mowing line, square Ø 3 mm x 5 m
	0000 930 2644	1	Mowing line, square Ø 3 mm x 53 m (B)
13		2	Mowing line, square Ø 3.3 mm x 4 m
	0000 930 2645	1	Mowing line, square Ø 3.3 mm x 38 m (B)
14		2	Mowing line, pentagonal Ø 2.7 mm x 6 m
	0000 930 3343	1	Mowing line, pentagonal Ø 2.7 mm x 77 m (B)
15		2	Mowing line, pentagonal Ø 3 mm x 5 m
	0000 930 3344	1	Mowing line, pentagonal Ø 3 mm x 58 m (B)
16		2	Mowing line, pentagonal Ø 3.3 mm x 4 m
	0000 930 3345	1	Mowing line, pentagonal Ø 3.3 mm x 23 m (B)

AutoCut 46-2

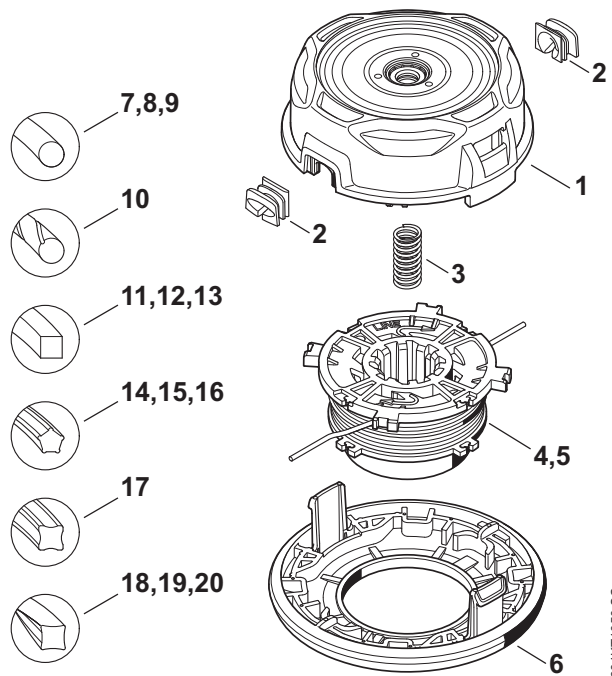

681KT1050 SC

No.	Part number	Qty.	Designation
	4003 710 2115	1	Mowing head AutoCut 46-2
			□ 1 - 4, 6
17		2	Mowing line, X-shaped Ø 2.7 mm x 6 m
	0000 930 3411	1	Mowing line, X-shaped Ø 2.7 mm x 65 m (B) USA
18		2	Mowing line CF3 Pro Ø 2.7 mm x 6 m
	0000 930 4301	1	Mowing line CF3 Pro Ø 2.7 mm x 26 m 3K (B)
19		2	Mowing line CF3 Pro Ø 3.0 mm x 5 m
	0000 930 4302	1	Mowing line CF3 Pro Ø 3.0 mm x 21 m 3K (B)
20		2	Mowing line CF3 Pro Ø 3.3 mm x 4 m
	0000 930 4311	1	Mowing line CF3 Pro Ø 3.3 mm x 34 m 3K (B)

AutoCut 40-4

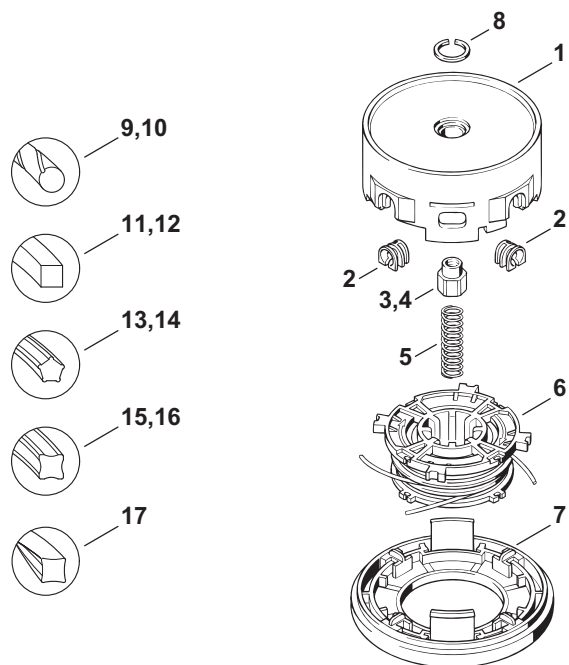

681KT114 SC

No.	Part number	Qty.	Designation
	4005 710 2100	1	Mowing head AutoCut 40-4
			□ 1 - 3, 5 - 8
1	4005 710 9600	1	Top part
2	4003 713 8301	4	Sleeve
3	4005 713 6800	1	Collar nut M14x1.5 l/h thread
4	4003 713 6801	1	Collar nut M12x1.5 l/h thread
5	0000 997 1601	1	Helical spring, spring
	4003 710 4305	1	Spool with nylon line □ 6
6	4003 713 3012	1	Spool, spool with nylon line
7	4003 713 9705	1	Bottom part
8	4111 716 9300	1	Ring
9	0000 930 2419	1	Mowing line, round, quiet Ø 2.4 mm x 14 m (B)
10	0000 930 2422	1	Mowing line, round, quiet Ø 2.7 mm x 9 m (B)
11	0000 930 2640	1	Mowing line, square Ø 2.4 mm x 41 m (B)
12	0000 930 2642	1	Mowing line, square Ø 2.7 mm x 32 m (B)
13	0000 930 3340	1	Mowing line, pentagonal Ø 2.4 mm x 48 m (B)
14	0000 930 3343	1	Mowing line, pentagonal Ø 2.7 mm x 77 m (B)
15	0000 930 3410	1	Mowing line, X-shaped Ø 2.4 mm x 83 m (B) USA
16	0000 930 3411	1	Mowing line, X-shaped Ø 2.7 mm x 65 m (B) USA
17	0000 930 4301	1	Mowing line CF3 Pro Ø 2.7 mm x 26 m 3K (B)

AutoCut 56-2

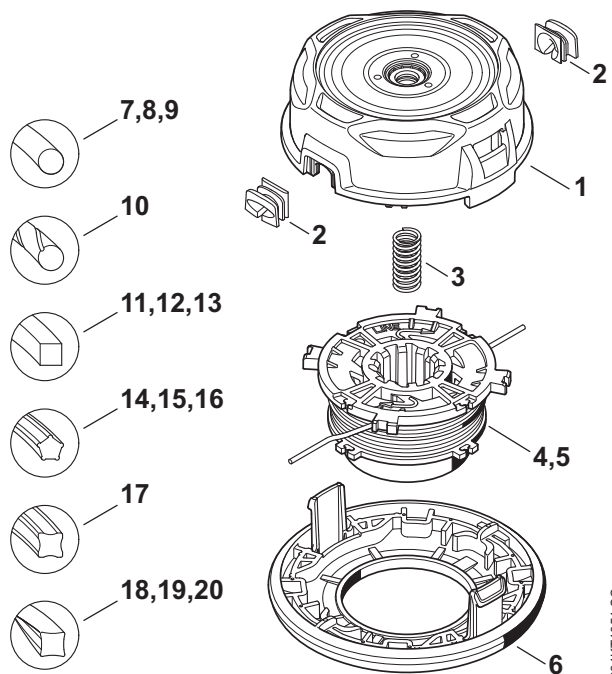

No.	Part number	Qty.	Designation
	4005 710 2107	1	Mowing head AutoCut 56-2 □ 1 - 4, 6
1	4005 710 9601	1	Top part
2	4002 713 8307	2	Sleeve
3	0000 997 3102	1	Helical spring, spring
4	4003 710 4307	1	Spool with nylon line □ 5
5	4003 713 3001	1	Spool, spool with nylon line
6	4005 713 9701	1	Bottom part
7		2	Mowing line, round Ø 2.7 mm x 6 m
	0000 930 2341	1	Mowing line, round Ø 2.7 mm x 9 m (B)
8		2	Mowing line, round Ø 3 mm x 5 m
	0000 930 2344	1	Mowing line, round Ø 3 mm x 53 m (B)
9		2	Mowing line, round Ø 3.3 mm x 4 m
	0000 930 2345	1	Mowing line, round Ø 3.3 mm x 6 m (B)
10		2	Mowing line, round, quiet Ø 2.7 mm x 6 m
	0000 930 2422	1	Mowing line, round, quiet Ø 2.7 mm x 9 m (B)
11		2	Mowing line, square Ø 2.7 mm x 6 m
	0000 930 2642	1	Mowing line, square Ø 2.7 mm x 32 m (B)
12		2	Mowing line, square Ø 3 mm x 5 m
	0000 930 2644	1	Mowing line, square Ø 3 mm x 53 m (B)
13		2	Mowing line, square Ø 3.3 mm x 4 m
	0000 930 2645	1	Mowing line, square Ø 3.3 mm x 38 m (B)
14		2	Mowing line, pentagonal Ø 2.7 mm x 6 m
	0000 930 3343	1	Mowing line, pentagonal Ø 2.7 mm x 77 m (B)
15		2	Mowing line, pentagonal Ø 3 mm x 5 m
	0000 930 3344	1	Mowing line, pentagonal Ø 3 mm x 58 m (B)
16		2	Mowing line, pentagonal Ø 3.3 mm x 4 m
	0000 930 3345	1	Mowing line, pentagonal Ø 3.3 mm x 4 m
17		2	Mowing line, X-shaped Ø 2.7 mm x 6 m
	0000 930 3411	1	Mowing line, X-shaped Ø 2.7 mm x 65 m (B) USA

AutoCut 56-2

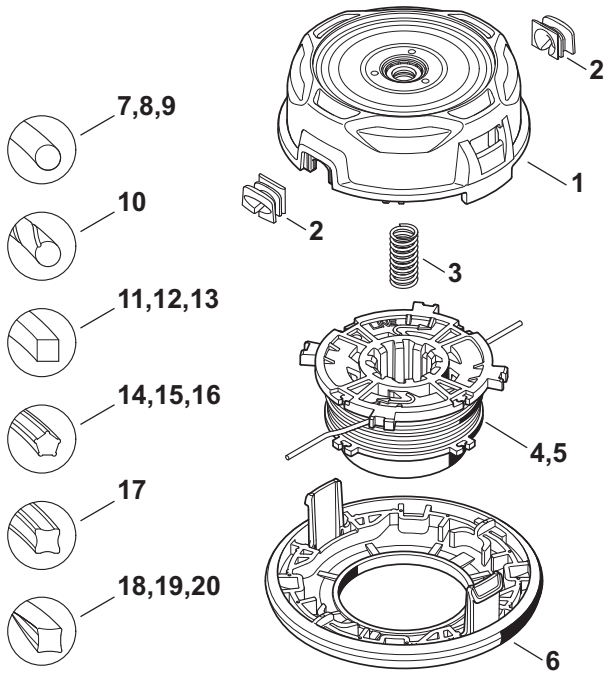

No.	Part number	Qty.	Designation
	4005 710 2107	1	Mowing head AutoCut 56-2
			□ 1 - 4, 6
18		2	Mowing line CF3 Pro Ø 2.7 mm x 6 m
	0000 930 4301	1	Mowing line CF3 Pro Ø 2.7 mm x 26 m 3K (B)
19		2	Mowing line CF3 Pro Ø 3.0 mm x 5 m
	0000 930 4302	1	Mowing line CF3 Pro Ø 3.0 mm x 21 m 3K (B)
20		2	Mowing line CF3 Pro Ø 3.3 mm x 4 m
	0000 930 4311	1	Mowing line CF3 Pro Ø 3.3 mm x 34 m 3K (B)

SuperCut 20-2

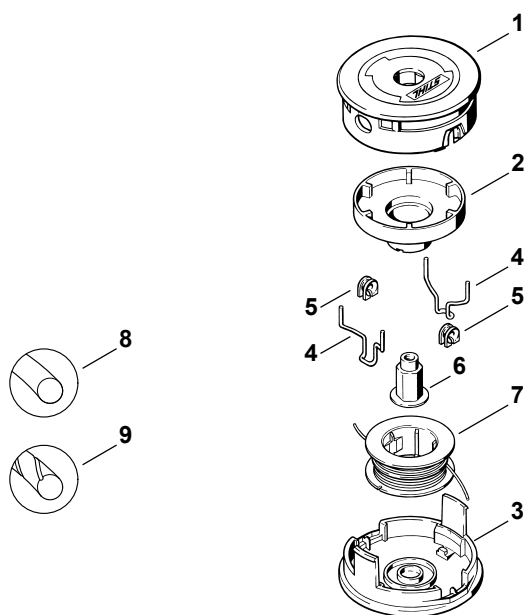

681K1597 SC

No.	Part number	Qty.	Designation
	4002 710 2162	1	Mowing head SuperCut 20-2
			□ 1 - 8
1	4002 710 9615	1	Top part
2	4002 713 7315	1	Index plate, switching cam
3	4002 713 9715	1	Bottom part
4	4002 713 3400	2	Barrier bar
5	4002 713 8310	2	Sleeve
6	4002 713 6805	1	Collar nut M10x1 l/h thread
	4002 710 4309	1	Spool with nylon line □ 7, 8
7	4002 713 3015	1	Spool, spool with nylon line
8		2	Mowing line, round Ø 2.4 mm x 3 m
	0000 930 2338	1	Mowing line, round Ø 2.4 mm x 14 m (A,B)
9		2	Mowing line, round, quiet Ø 2.4 mm x 3 m (B)
	0000 930 2419	1	Mowing line, round, quiet Ø 2.4 mm x 14 m (A,B)

SuperCut 40-2

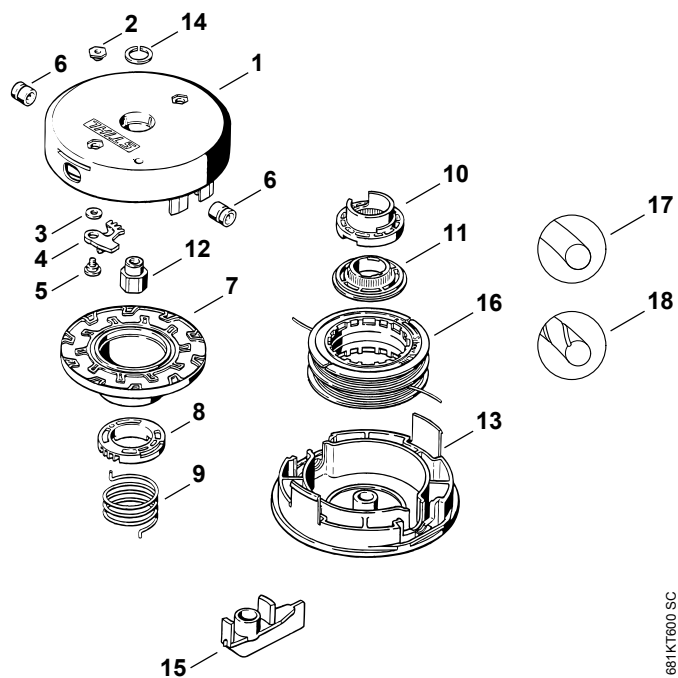

681KT600 SC

No.	Part number	Qty.	Designation
	4003 710 2140	1	Mowing head SuperCut 40-2
			□ 1 - 17
1	4002 713 9605	1	Top part
2	4002 713 6802	2	Collar nut
3	0000 958 0516	2	Washer, disk
4	4002 713 7205	2	Pawl
5	4002 713 6500	2	Collar screw
6	4002 713 8305	2	Sleeve
7	4002 713 7300	1	Index plate, switching cam
8	4002 713 6905	1	Synchronizer ring
9	4002 998 4000	1	Torsion spring
10	4002 713 6900	1	Adjuster ring
11	4002 713 6910	1	Ratchet wheel
12	4003 713 6800	1	Collar nut M12x1.5 l/h thread
13	4003 713 9700	1	Bottom part
14	4111 716 9300	1	Ring
15	4002 893 1300	1	Tensioning wrench
	4002 710 4300	1	Spool with nylon line □ 16, 17
16	4002 713 3005	1	Spool, spool with nylon line
17		2	Mowing line, round Ø 2.4 mm x 3.75 m
	0000 930 2338	1	Mowing line, round Ø 2.4 mm x 14 m (A,B)
	0000 930 2528	1	Mowing line, round Ø 2.4 mm x 15 m (A,B)
18		2	Mowing line, round, quiet Ø 2.4 mm x 3.75 m (B)
	0000 930 2419	1	Mowing line, round, quiet Ø 2.4 mm x 14 m (A,B)

PolyCut 2-2

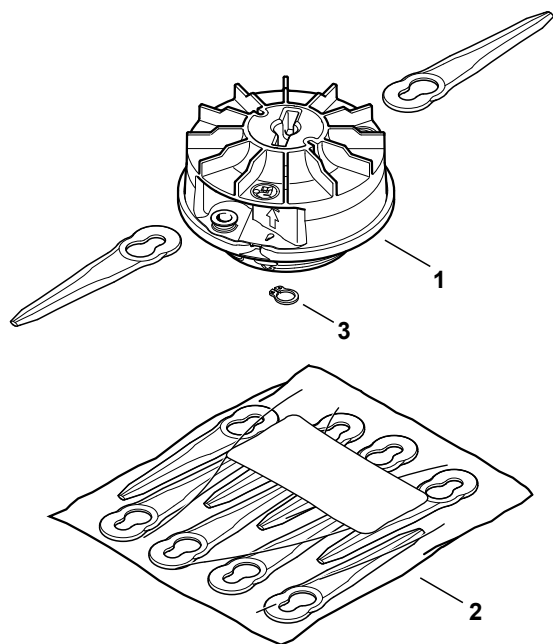

0000-GXX-2524-A0

No.	Part number	Qty.	Designation
1	4008 710 2102	1	Mowing head PolyCut 2-2 □ 2 - 3
2	4008 007 1000	1	Set of blades (8 pieces)
3	9455 621 0570	1	Circlip DIN471-8x0.8

PolyCut 5-3

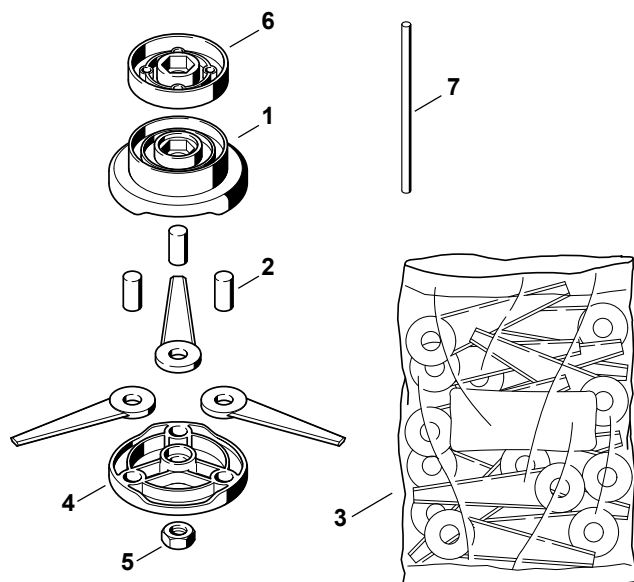

681KT601 SC

No.	Part number	Qty.	Designation
	4004 710 2131	1	Mowing head PolyCut 5-3
			□ 1 - 7
1	4004 713 9601	1	Top part
2	4004 713 6600	3	Bolt
3	4111 007 1001	3	Set of blades (12 pieces)
4	4004 713 9701	1	Bottom part
5	9211 260 1400	1	Nut DIN936-M12-04
6	4130 713 1501	1	Thrust plate
7	4130 893 7800	1	Locking pin

PolyCut 6-3

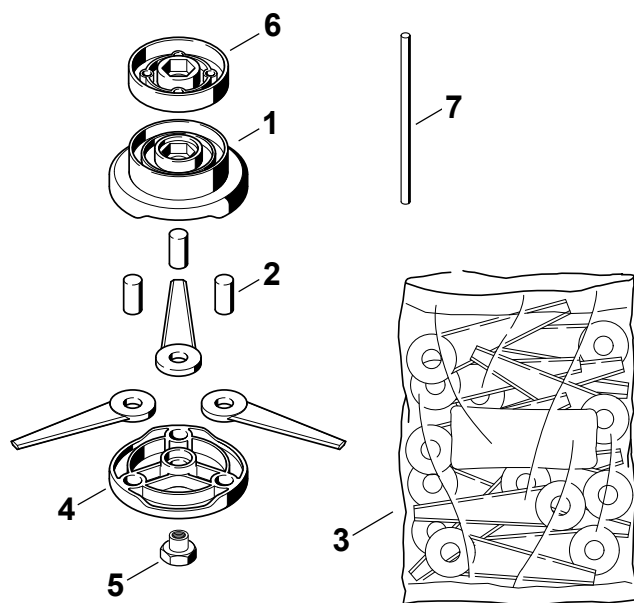

681KT602 KN

No.	Part number	Qty.	Designation
	4006 710 2110	1	Mowing head PolyCut 6-3
			□ 1 - 7
1	4004 713 9601	1	Top part
2	4004 713 6600	3	Bolt
3	4111 007 1001	3	Set of blades (12 pieces)
4	4004 713 9701	1	Bottom part
5	4006 713 6800	1	Collar nut
6	4140 713 1501	1	Thrust plate
7	4130 893 7800	1	Locking pin

PolyCut 7-3

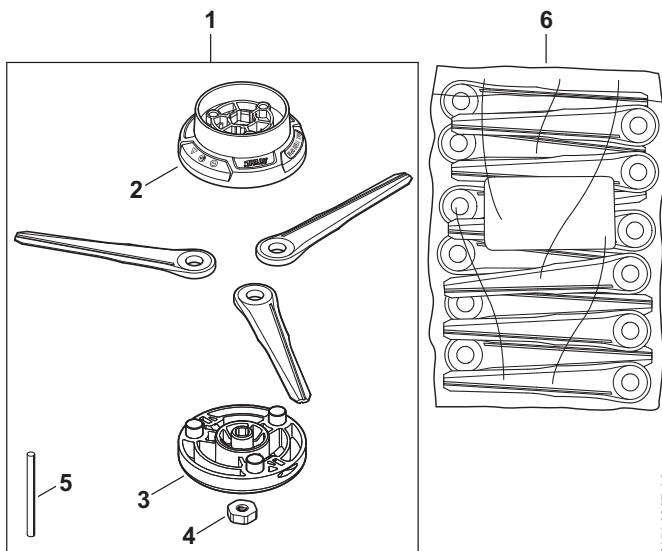

0000-GXX-6607-A0

No.	Part number	Qty.	Designation
1	4006 710 2127	1	Mowing head PolyCut 7-3 □ 2- 5
2	4006 710 9602	1	Top part
3	4006 710 9700	1	Bottom part
4	0000 955 0801	1	Hexagon nut M8
5	4130 893 7800	1	Locking pin
6	4002 007 1000	1	Set of blades (12 pieces)

PolyCut 20-3

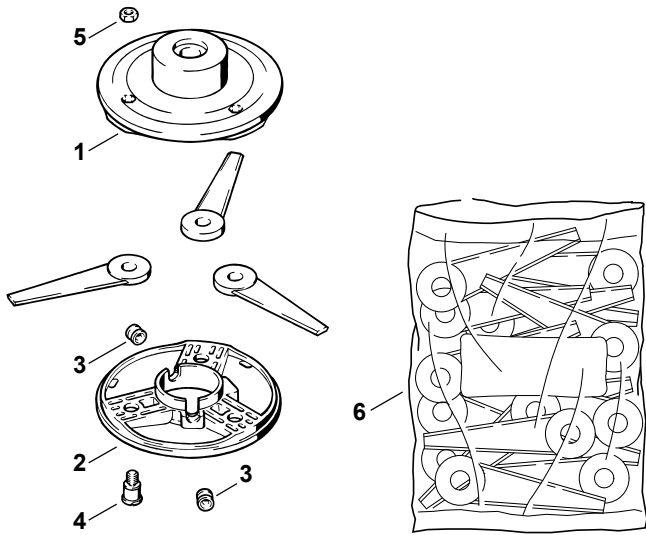

681KT657 SC

No.	Part number	Qty.	Designation
	4002 710 2130	1	Mowing head PolyCut 20-3
			□ 1 - 6
1	4002 710 9601	1	Top part
2	4002 713 9700	1	Bottom part
3	4002 713 8300	2	Sleeve
4	4111 710 8700	3	Collar screw
5	9210 319 0900	3	Nut DIN934-M6-10
6	4111 007 1001	1	Set of blades (12 pieces)

PolyCut 27-3

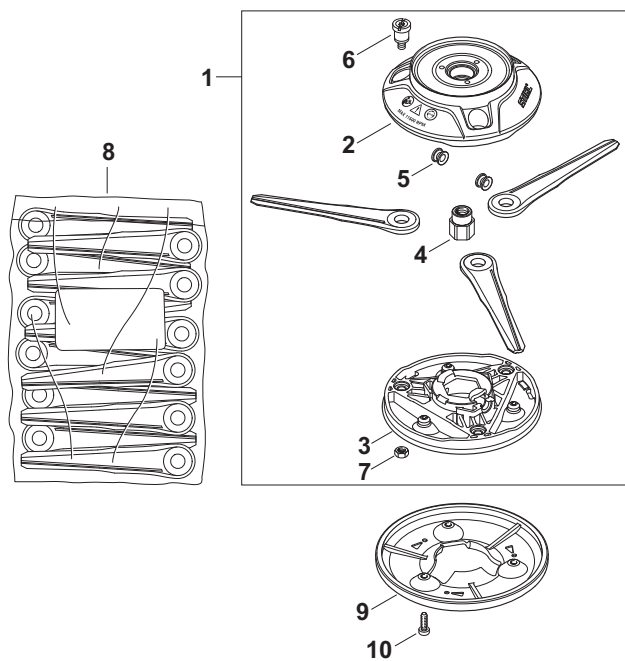

No.	Part number	Qty.	Designation
1	4002 710 2176	1	Mowing head PolyCut 27-3 □ 2 - 7
2	4002 713 9611	1	Top part
3	4002 710 9700	1	Bottom part
4	4002 713 6801	1	Collar nut M10x11/h thread
5	4002 713 8300	2	Sleeve
6	4111 710 8700	3	Collar screw
7	9210 319 0900	3	Nut DIN934-M6-10
8	4002 007 1000	1	Set of blades (12 pieces)
9	4003 007 1000	1	Deflector kit □ 10
10	9074 477 4130	3	Screw IS-P5x16

0000-GXX-6608-A0

PolyCut 40-3

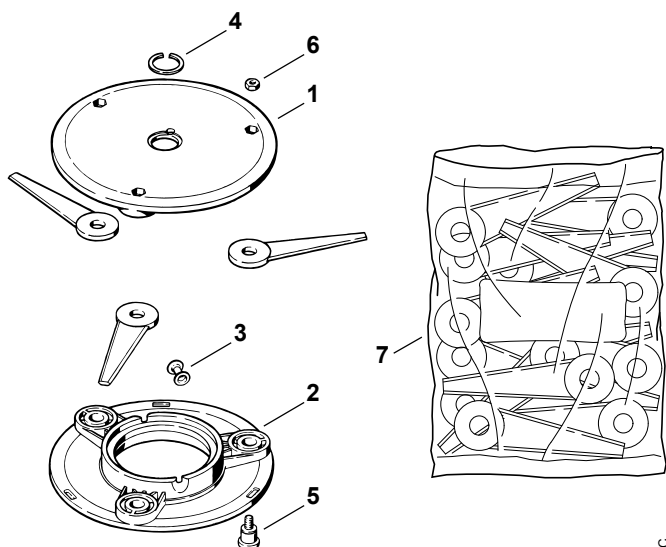

681KT658 SC

No.	Part number	Qty.	Designation
	4111 710 2100	1	Mowing head PolyCut 40-3 (C)
			□ 1 - 7
1	4111 713 9601	1	Top part
2	4111 713 9701	1	Bottom part
3	4002 713 8300	2	Sleeve
4	4111 716 9300	1	Ring
5	4111 710 8700	3	Collar screw
6	9210 319 0900	3	Nut DIN934-M6-10
7	4111 007 1001	1	Set of blades (12 pieces)

PolyCut 41-3

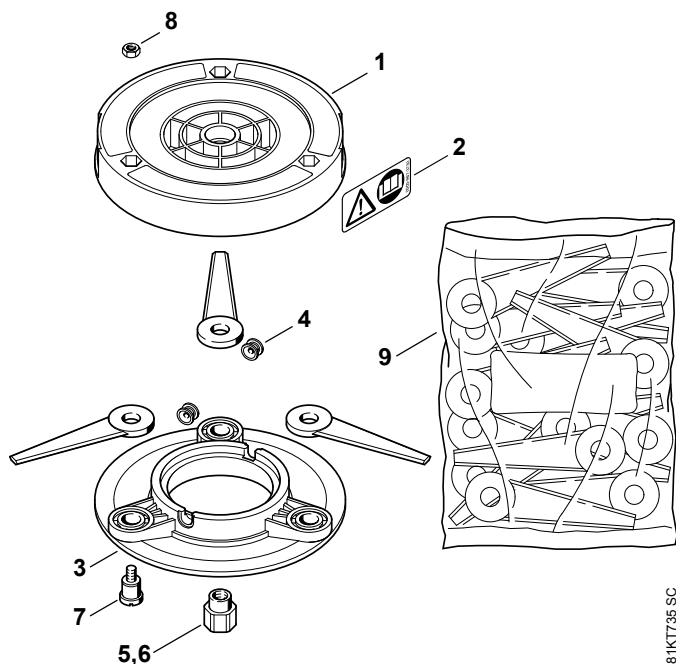

681KT735 SC

No.	Part number	Qty.	Designation
	4003 710 2113	1	Mowing head PolyCut 41-3
			□ 1 - 9
1	4003 713 9602	1	Top part
2	0000 967 3730	1	Warning plate Pictogram
3	4111 713 9701	1	Bottom part
4	4002 713 8300	2	Sleeve
5	4003 713 6801	1	Collar nut M12x1.5 l/h thread
6	4005 713 6800	1	Collar nut M14x1.5 l/h thread
7	4111 710 8700	3	Collar screw
8	9210 319 0900	3	Nut DIN934-M6-10
9	4111 007 1001	1	Set of blades (12 pieces)

PolyCut 47-3

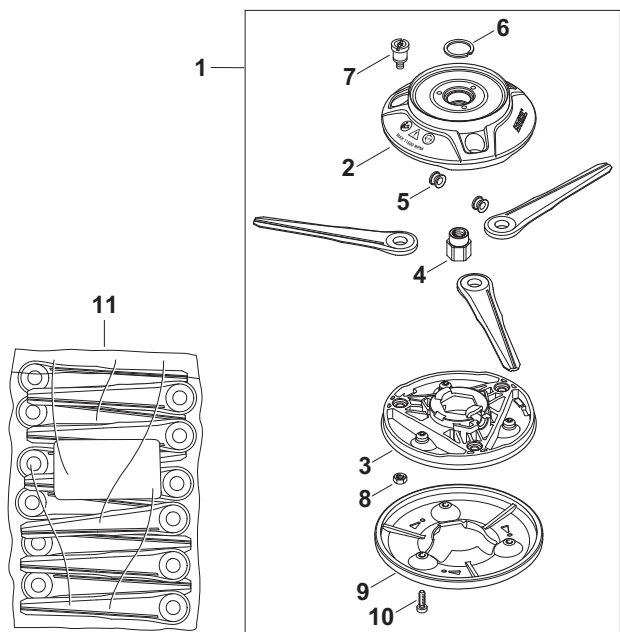

0000-GXX-6609-A0

No.	Part number	Qty.	Designation
1	4003 710 2117	1	Mowing head PolyCut 47-3 □ 2 -10
2	4003 713 9606	1	Top part
3	4002 710 9700	1	Bottom part
4	4003 713 6801	1	Collar nut M12x1.5 l/h thread
5	4002 713 8300	2	Sleeve
6	4111 716 9300	1	Ring
7	4111 710 8700	3	Collar screw
8	9210 319 0900	3	Nut DIN934-M6-10
9	4003 007 1000	1	Deflector kit □ 10
10	9074 477 4130	3	Screw IS-P5x16
11	4002 007 1000	1	Set of blades (12 pieces)

DuroCut 5-2

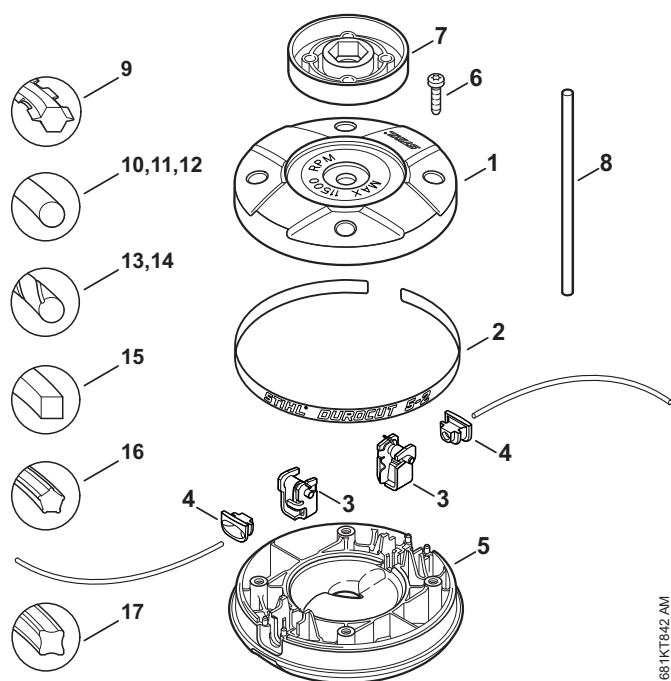

681KT842 AM

No.	Part number	Qty.	Designation
	4006 710 2131	1	Mowing head DuroCut 5-2
			□ 1 - 9
	4006 710 2125	1	Mowing head DuroCut 5-2 (C)
1	4006 710 9600	1	Top part
2	4006 967 4604	1	Instruction label
3	4002 710 4500	2	Holder
4	4006 713 8301	2	Sleeve
5	4006 713 9702	1	Bottom part
6	9074 477 4135	4	Screw IS-P5x20
7	4140 713 1501	1	Thrust plate
8	4130 893 7800	1	Locking pin
9	0000 930 3503	2	Mowing line, serrated Ø 2x195 mm 48 pieces
10		2	Mowing line, round Ø 1.6x195 mm (B)
	0000 930 2334	1	Mowing line, round Ø 1.6 mm x 19 m (A,B)
11		2	Mowing line, round Ø 2x195 mm (B)
	0000 930 2335	1	Mowing line, round, Ø 2 mm x 14 m (A,B)
12		2	Mowing line, round Ø 2.4x195 mm (B)
	0000 930 2338	1	Mowing line, round Ø 2.4 mm x 14 m (A,B)
13		2	Mowing line, round, quiet Ø 2x185 mm (B)
	0000 930 2416	1	Mowing line, round, quiet Ø 2 mm x 14 m (A,B)
14		2	Mowing line, round, quiet Ø 2.4x195 mm (B)
	0000 930 2419	1	Mowing line, round, quiet Ø 2.4 mm x 14 m (A,B)
15		2	Mowing line, square Ø 2.4x195 mm (B)
	0000 930 2640	1	Mowing line, square Ø 2.4 mm x 41 m (A,B)
16		2	Mowing line, pentagonal Ø 2.4x195 mm (B)
	0000 930 3340	1	Mowing line, pentagonal Ø 2.4 mm x 48 m (A,B)
17		2	Mowing line, X-shaped Ø 2.4x195 mm (B)
	0000 930 3410	1	Mowing line, X-shaped Ø 2.4 mm x 83 m (A,B) USA

DuroCut 20-2

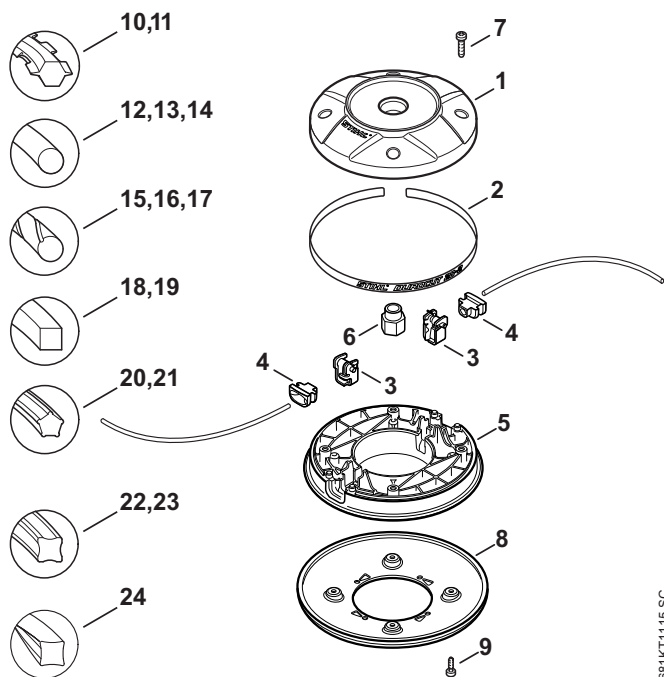

681KT115 SC

No.	Part number	Qty.	Designation
	4002 710 2182	1	Mowing head DuroCut 20-2
			□ 1 - 7, 11
	4002 710 2167	1	Mowing head DuroCut 20-2 (C)
1	4002 713 9607	1	Top part
2	4002 967 4618	1	Instruction label
3	4002 710 4500	2	Holder
4	4002 713 8304	2	Sleeve
5	4002 713 9703	2	Bottom part
6	4002 713 6801	1	Collar nut M10x1 l/h thread
7	9074 477 4135	4	Screw IS-P5x20
	4005 007 1001	1	Guard kit (B) □ 8, 9
8	4005 713 4500	1	Guard (B)
9	9074 478 3005	4	Pan head self-tapping screw IS-P4x14 (B)
10	0000 930 3503	2	Mowing line, serrated Ø 2x195 mm (B) 48 pieces
11	0000 930 3504	2	Mowing line, serrated Ø 3x185 mm 48 pieces
12	0000 930 2335	1	Mowing line, round, Ø 2 mm x 14 m (B)
13	0000 930 2338	1	Mowing line, round Ø 2.4 mm x 14 m (B)
14	0000 930 2341	1	Mowing line, round Ø 2.7 mm x 9 m (B)
15	0000 930 2416	1	Mowing line, round, quiet Ø 2 mm x 14 m (B)
16	0000 930 2419	1	Mowing line, round, quiet Ø 2.4 mm x 14 m (B)
17	0000 930 2422	1	Mowing line, round, quiet Ø 2.7 mm x 9 m (B)
18	0000 930 2640	1	Mowing line, square Ø 2.4 mm x 41 m (B)
19	0000 930 2642	1	Mowing line, square Ø 2.7 mm x 32 m (B)
20	0000 930 3340	1	Mowing line, pentagonal Ø 2.4 mm x 48 m (B)
21	0000 930 3343	1	Mowing line, pentagonal Ø 2.7 mm x 77 m (B)
22	0000 930 3410	1	Mowing line, X-shaped Ø 2.4 mm x 83 m (B) USA
23	0000 930 3411	1	Mowing line, X-shaped Ø 2.7 mm x 65 m (B) USA
24	0000 930 4301	1	Mowing line CF3 Pro Ø 2.7 mm x 26 m 3K (B)

DuroCut 40-4

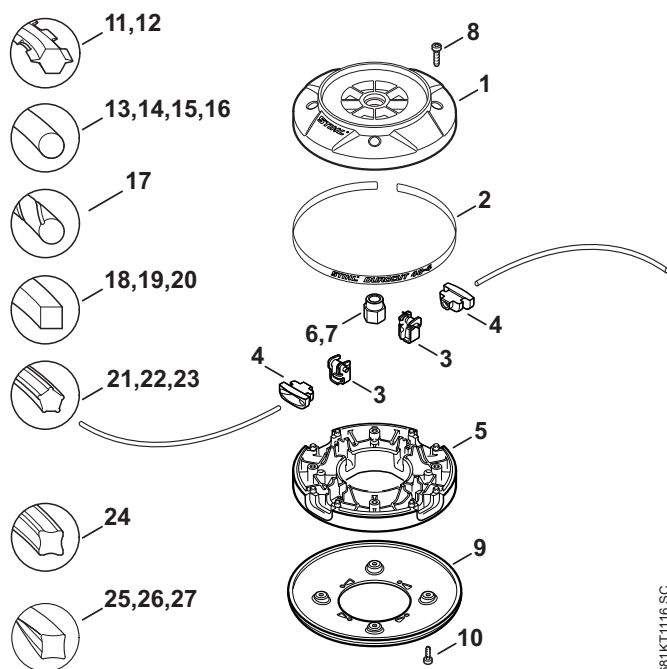

681KT1116 SC

No.	Part number	Qty.	Designation
	4005 710 2114	1	Mowing head DuroCut 40-4
			□ 1 - 10, 12
	4005 710 2106	1	Mowing head DuroCut 40-4 (C)
1	4003 713 9603	1	Top part
2	4005 967 4604	1	Instruction label
3	4005 710 4500	4	Holder
4	4005 713 8301	4	Sleeve
5	4005 713 9700	1	Bottom part
6	4003 713 6801	1	Collar nut M12x1.5 l/h thread
7	4005 713 6800	1	Collar nut M14x1.5 l/h thread
8	9074 477 4135	4	Screw IS-P5x20
9	4005 713 4500	1	Deflector
10	9074 478 2970	4	Screw IS-P4x10
11	0000 930 3504	4	Mowing line, serrated Ø 3x185 mm (B) 48 pieces
12	0000 930 3505	4	Mowing line, serrated Ø 4x215 mm 48 pieces
13	0000 930 2341	1	Mowing line, round Ø 2.7 mm x 9 m (B)
14	0000 930 2344	1	Mowing line, round Ø 3 mm x 53 m (B)
15	0000 930 2345	1	Mowing line, round Ø 3.3 mm x 6 m (B)
16	0000 930 3605	4	Mowing line, round Ø 4x215 mm (B) 48 pieces
17	0000 930 3708		Mowing line, round, quiet Ø 4 mm x 27 m (B)
18	0000 930 2642	1	Mowing line, square Ø 2.7 mm x 32 m (B)
19	0000 930 2644	1	Mowing line, square Ø 3 mm x 53 m (B)
20	0000 930 2645	1	Mowing line, square Ø 3.3 mm x 38 m (B)
21	0000 930 3343	1	Mowing line, pentagonal Ø 2.7 mm x 77 m (B)
22	0000 930 3344	1	Mowing line, pentagonal Ø 3 mm x 58 m (B)
23	0000 930 3345	1	Mowing line, pentagonal Ø 3.3 mm x 23 m (B)
24	0000 930 3411	1	Mowing line, X-shaped Ø 2.7 mm x 65 m (B) USA
25	0000 930 4301	1	Mowing line CF3 Pro Ø 2.7 mm x 26 m 3K (B)
26	0000 930 4302	1	Mowing line CF3 Pro Ø 3.0 mm x 21 m 3K (B)
27	0000 930 4311	1	Mowing line CF3 Pro Ø 3.3 mm x 34 m 3K (B)

FixCut 5-2

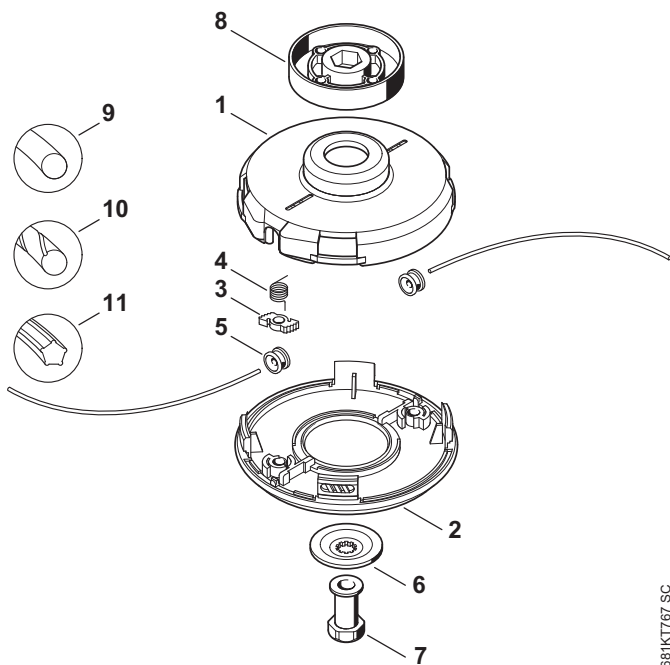

681KT767 SC

No.	Part number	Qty.	Designation
	4006 710 2117	1	Mowing head FixCut 5-2
			□ 2 - 8, 10
1		1	Top (D)
2	4002 713 9702	1	Bottom part
3	4001 713 7200	2	Pawl
4	4001 998 0400	2	Torsion spring
5	4001 713 8300	2	Sleeve
6	4130 713 1600	1	Thrust washer
7	4006 713 6801	1	Collar nut M8
8	4140 713 1501	1	Thrust plate
9		2	Mowing line, round Ø 2.4x203 mm (D)
	0000 930 2310	1	Mowing line, round Ø 2.4x203 mm (A,B) 50 pieces
10			Mowing line, round, quiet Ø 2.4x203 mm (D)
	0000 930 2419	1	Mowing line, round, quiet Ø 2.4 mm x 14 m (A,B)
11	0000 930 3340	1	Mowing line, pentagonal Ø 2.4 mm x 48 m (B)

FixCut 25-2

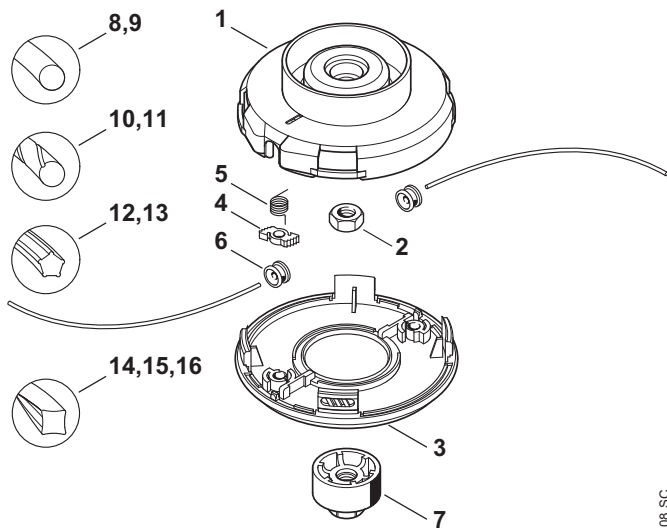

No.	Part number	Qty.	Designation
	4006 710 2157	1	Mowing head FixCut 5-2
			□ 1 - 6, 10
1		1	Top (D)
2	9211 260 1350	1	Nut DIN936-M10x1LH-05
3	4002 713 9702	1	Bottom part
4	4001 713 7200	2	Pawl
5	4001 998 0400	2	Torsion spring
6	4001 713 8300	2	Sleeve
7	4001 710 9400	1	Thrust piece USA, CDN
8		2	Mowing line, round Ø 2.4x203 mm (D)
	0000 930 2310	1	Mowing line, round Ø 2.4x203 mm (A,B) 50 pieces
9	0000 930 2312	1	Mowing line, round Ø 3.3x203 mm (B) 50 pieces USA, CDN
10		1	Mowing line, round, quiet Ø 2.4x203 mm (D)
	0000 930 2419	1	Mowing line, round, quiet Ø 2.4 mm x 14 m (A,B)
11	0000 930 2422	1	Mowing line, round, quiet Ø 2.7 mm x 9 m (A,B)
12	0000 930 3340	1	Mowing line, pentagonal Ø 2.4 mm x 48 m (B)
13	0000 930 3344	1	Mowing line, pentagonal Ø 3 mm x 58 m (B)
14	0000 930 4301	1	Mowing line CF3 Pro Ø 2.7 mm x 26 m 3K (B)
15	0000 930 4302	1	Mowing line CF3 Pro Ø 3.0 mm x 21 m 3K (B)
16	0000 930 4311	1	Mowing line CF3 Pro Ø 3.3 mm x 34 m 3K (B)

FixCut 31-2

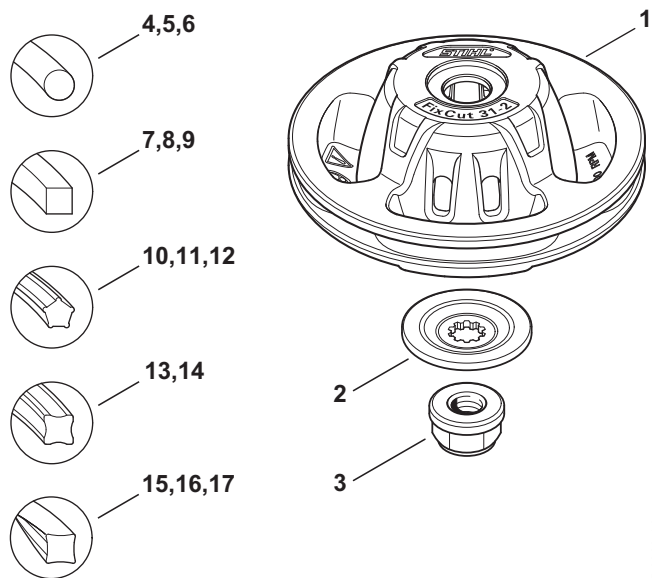

No.	Part number	Qty.	Designation
	4006 710 2157	1	Mowing head FixCut 5-2 □ 1 - 3
1	4001 710 2105	1	Mowing head FixCut 31-2
2	4130 713 1600	1	Thrust washer
3	4126 642 7600	1	Collar nut M10x1 l/h thread
4	0000 930 2338	1	Mowing line, round Ø 2.4 mm x 14 m (B)
5	0000 930 2341	1	Mowing line, round Ø 2.7 mm x 9 m (B)
6	0000 930 2345	1	Mowing line, round Ø 3.3 mm x 6 m (B)
7	0000 930 2601	1	Mowing line, square Ø 2.4 mm x 253 m dark green (B)
8	0000 930 2626	1	Mowing line, square Ø 2.7 mm x 208 m dark green (B)
9	0000 930 2645	1	Mowing line, square Ø 3.3 mm x 38 m (B)
10	0000 930 3340	1	Mowing line, pentagonal Ø 2.4 mm x 48 m
11	0000 930 3342	1	Mowing line, pentagonal Ø 2.7 mm x 38 m (B)
12	0000 930 3345	1	Mowing line, pentagonal Ø 3.3 mm x 24 m (B)
13	0000 930 3410	1	Mowing line, X-shaped Ø 2.4 mm x 86 m (B)
14	0000 930 3404	1	Mowing line, X-shaped Ø 2.7 mm x 222 m (B)
15	0000 930 4300	1	Mowing line CF3 Pro Ø 2.4 mm x 35 m 3K (B)
16	0000 930 4301	1	Mowing line CF3 Pro Ø 2.7 mm x 26 m 3K (B)
17	0000 930 4311	1	Mowing line CF3 Pro Ø 3.3 mm x 36.0 m 3K (B)

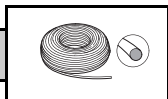

Mowing lines, round

Dimension	Color	Part number	Designation
Ø 1.4 mm	Translucent		
16 m		0000 930 2284	Mowing line, round Ø 1.4 mm x 16 m
Ø 1.6 mm	Blue		
19 m		0000 930 2334	Mowing line, round, Ø 1.6 mm x 19 m
Ø 2.0 mm	Green		
14 m		0000 930 2335	Mowing line, round, Ø 2 mm x 14 m
60 m		0000 930 2336	Mowing line, round, Ø 2 mm x 60 m
119 m		0000 930 2337	Mowing line, round, Ø 2 mm x 119 m
360 m		0000 930 2263	Mowing line, round, Ø 2 mm x 360 m
601 m		0000 930 2264	Mowing line, round, Ø 2 mm x 601 m
1503 m		0000 930 2575	Mowing line, round, Ø 2 mm x 1503 m
Ø 2.4 mm	Orange		
14 m		0000 930 2338	Mowing line, round Ø 2.4 mm x 14 m
41 m		0000 930 2339	Mowing line, round, Ø 2.4 mm x 41 m
83 m		0000 930 2340	Mowing line, round, Ø 2.4 mm x 83 m
253 m		0000 930 2246	Mowing line, round, Ø 2.4 mm x 253 m
420 m		0000 930 2247	Mowing line, round, Ø 2.4 mm x 420 m
1053 m		0000 930 2573	Mowing line, round, Ø 2.4 mm x 1053 m
Ø 2.7 mm	Red		
9 m		0000 930 2341	Mowing line, round Ø 2.7 mm x 9 m
32 m		0000 930 2342	Mowing line, round, Ø 2.7 mm x 32 m
65 m		0000 930 2343	Mowing line, round, Ø 2.7 mm x 65 m
208 m		0000 930 2227	Mowing line, round, Ø 2.7 mm x 208 m
347 m		0000 930 2289	Mowing line, round, Ø 2.7 mm x 347 m
869 m		0000 930 2571	Mowing line, round, Ø 2.7 mm x 869 m

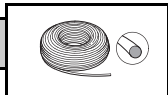

Mowing lines, round

Dimension	Color	Part number	Designation
Ø 3.0 mm	Yellow		
53 m		0000 930 2344	Mowing line, round, Ø 3 mm x 53 m
162 m		0000 930 2542	Mowing line, round, Ø 3 mm x 162 m
271 m		0000 930 2543	Mowing line, round, Ø 3 mm x 271 m
Ø 3.3 mm	Black		
6 m		0000 930 2345	Mowing line, round Ø 3.3 mm x 6 m
19 m		0000 930 2346	Mowing line, round, Ø 3.3 mm x 19 m
38 m		0000 930 2347	Mowing line, round, Ø 3.3 mm x 38 m
137 m		0000 930 2287	Mowing line, round, Ø 3.3 mm x 137 m
228 m		0000 930 2290	Mowing line, round, Ø 3.3 mm x 228 m
573 m		0000 930 2569	Mowing line, round, Ø 3.3 mm x 573 m
Ø 4.0 mm	Dark green		
27 m		0000 930 3607	Mowing line, round, Ø 4 mm x 27 m

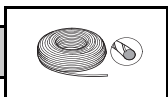

Mowing lines, round, quiet

Dimension	Color	Part number	Designation
Ø 1.6 mm	Blue		
19 m		0000 930 2415	Mowing line, round, quiet Ø 1.6 mm x 19 m
Ø 2.0 mm	Green		
14 m		0000 930 2416	Mowing line, round, quiet Ø 2 mm x 14 m
60 m		0000 930 2418	Mowing line, round, quiet Ø 2 mm x 60 m
119 m		0000 930 2424	Mowing line, round, quiet Ø 2 mm x 119 m
Ø 2.4 mm	Orange		
14 m		0000 930 2419	Mowing line, round, quiet Ø 2.4 mm x 14 m
41 m		0000 930 2420	Mowing line, round, quiet Ø 2.4 mm x 41 m
83 m		0000 930 2421	Mowing line, round, quiet Ø 2.4 mm x 83 m
253 m		0000 930 2535	Mowing line, round, quiet Ø 2.4 mm x 253 m
Ø 2.7 mm	Red		
9 m		0000 930 2422	Mowing line, round, quiet Ø 2.7 mm x 9 m
65 m		0000 930 2423	Mowing line, round, quiet Ø 2.7 mm x 65 m

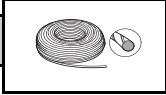

Mowing lines, round, quiet

Dimension	Color	Part number	Designation
Ø 4 mm	Dark green		
27 m		0000 930 3708	Mowing line, round, quiet Ø 4 mm x 27 m

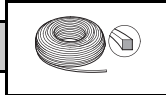

Mowing lines, square

Dimension	Color	Part number	Designation
Ø 2.4 mm	Orange		
41 m		0000 930 2640	Mowing line, square, Ø 2.4 mm x 41 m
83 m		0000 930 2641	Mowing line, square, Ø 2.4 mm x 83 m
253 m		0000 930 2612	Mowing line, square, Ø 2.4 mm x 253 m
420 m		0000 930 2613	Mowing line, square, Ø 2.4 mm x 420 m
Ø 2.7 mm	Red		
32 m		0000 930 2642	Mowing line, square, Ø 2.7 mm x 32 m
65 m		0000 930 2643	Mowing line, square, Ø 2.7 mm x 65 m
208 m		0000 930 2616	Mowing line, square, Ø 2.7 mm x 208 m
347 m		0000 930 2617	Mowing line, square, Ø 2.7 mm x 347 m
Ø 3.0 mm	Yellow		
53 m		0000 930 2644	Mowing line, square, Ø 3 mm x 53 m
162 m		0000 930 2619	Mowing line, square, Ø 3 mm x 162 m
271 m		0000 930 2620	Mowing line, square, Ø 3 mm x 271 m

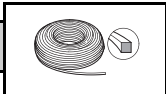

Mowing lines, square

Dimension	Color	Part number	Designation
Ø 3.3 mm	Black		
38 m		0000 930 2645	Mowing line, square, Ø 3.3 mm x 38 m
137 m		0000 930 2622	Mowing line, square, Ø 3.3 mm x 137 m
228 m		0000 930 2623	Mowing line, square, Ø 3.3 mm x 228 m
Ø 4.0 mm	Black		
28 m		0000 930 3611	Mowing line, square Ø 4 mm x 28 m

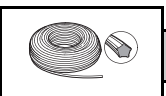

Mowing lines, pentagonal

Dimension	Color	Part number	Designation
Ø 2.4 mm	Orange		
48 m		0000 930 3340	Mowing line, pentagonal Ø 2.4 mm 48 m
97 m		0000 930 3341	Mowing line, pentagonal Ø 2.4 mm 97 m
291 m		0000 930 3339	Mowing line, pentagonal Ø 2.4 mm 291 m
Ø 2.7 mm	Red		
38 m		0000 930 3342	Mowing line, pentagonal Ø 2.7 mm 38 m
77 m		0000 930 3343	Mowing line, pentagonal Ø 2.7 mm 77 m
215 m		0000 930 3303	Mowing line, pentagonal Ø 2.7 mm 215 m
Ø 3.0 mm	Yellow		
58 m		0000 930 3344	Mowing line, pentagonal Ø 3 mm 58 m
203 m		0000 930 3305	Mowing line, pentagonal Ø 3 mm 203 m
339 m		0000 930 3306	Mowing line, pentagonal Ø 3 mm 339 m
Ø 3.3 mm	Black		
23 m		0000 930 3345	Mowing line, pentagonal Ø 3.3 mm 23 m
46 m		0000 930 3346	Mowing line, pentagonal Ø 3.3 mm 46 m

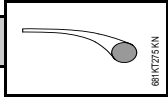

Mowing lines, round, pre-cut

Dimension	Color	Part number	Designation
Ø 2.4 mm	Orange		
50 m		0000 930 2315	Mowing line, round Ø 2.4 x 203 mm
100 m		0000 930 2317	Mowing line, round Ø 2.4 x 203 mm
Ø 3.3 mm	Black		
50 m		0000 930 2312	Mowing line, round Ø 3.3 x 203 mm
100 m		0000 930 2313	Mowing line, round Ø 3.3 x 203 mm
Ø 4.0 mm	Dark green		
48 m		0000 930 3605	Mowing line, round Ø 4 x 215 mm

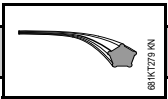

Mowing lines, pentagonal, pre-cut

Dimension	Color	Part number	Designation
Ø 2.4 mm	Orange		
50 m		0000 930 3316	Mowing line, pentagonal Ø 2.4 x 203 mm
100 m		0000 930 3317	Mowing line, pentagonal Ø 2.4 x 203 mm
Ø 3.3 mm	Yellow		
50 m		0000 930 3318	Mowing line, pentagonal Ø 3 x 203 mm
100 m		0000 930 3319	Mowing line, pentagonal Ø 3 x 203 mm

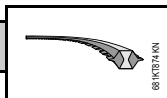

Mowing line, serrated, pre-cut

Dimension	Color	Part number	Designation
Ø 2.0 mm	Bronze		
48 m		0000 930 3503	Mowing line, serrated Ø 2 x 195 mm
Ø 3.0 mm	Silver		
48 m		0000 930 3504	Mowing line, serrated Ø 3 x 185 mm
Ø 4.0 mm	Gold		
48 m		0000 930 3505	Mowing line, serrated Ø 4 x 215 mm

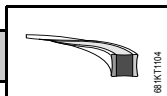

Mowing lines CF3 Pro

Dimension	Color	Part number	Designation
Ø 2.4 mm	Multi-colored		
35 m		0000 930 4300	Mowing line CF3 Pro Ø 2.4 mm x 35 m 3K
70 m		0000 930 4303	Mowing line CF3 Pro Ø 2.4 mm x 70 m 3K
212 m		0000 930 4313	Mowing line CF3 Pro Ø 2.4 mm x 212.0 m 3K
Ø 2.7 mm	Multi-colored		
27 m		0000 930 4301	Mowing line CF3 Pro Ø 2.7 mm x 26 m 3K
55 m		0000 930 4304	Mowing line CF3 Pro Ø 2.7 mm x 53 m 3K
172 m		0000 930 4314	Mowing line CF3 Pro Ø 2.7 mm x 172.0 m 3K
Ø 3.0 mm	Multi-colored		
22 m		0000 930 4302	Mowing line CF3 Pro Ø 3.0 mm x 21 m 3K
45 m		0000 930 4305	Mowing line CF3 Pro Ø 3.0 mm x 43 m 3K
134 m		0000 930 4315	Mowing line CF3 Pro Ø 3.0 mm x 134.0 m 3K
Ø 3.3 mm	Multi-colored		
36 m		0000 930 4311	Mowing line CF3 Pro Ø 3.3 mm x 34 m 3K
113 m		0000 930 4316	Mowing line CF3 Pro Ø 3.3 mm x 113.0 m 3K

Balancer, Sharpening Instructions and Sharpening Tools

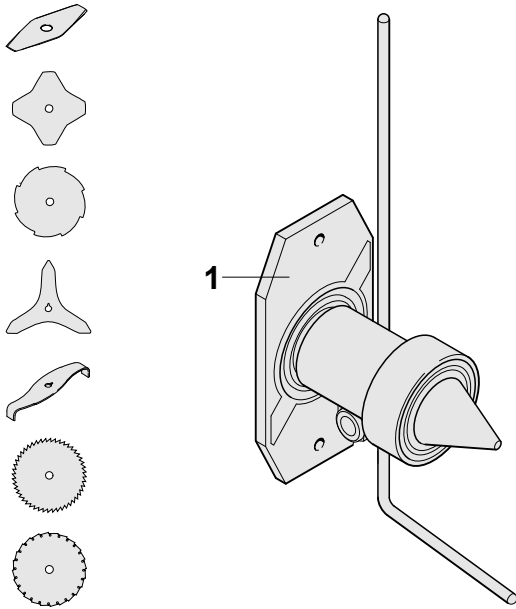

681KT338 KN

No.	Part number	Qty.	Designation
1	5910 850 2600	1	Balancer (B)

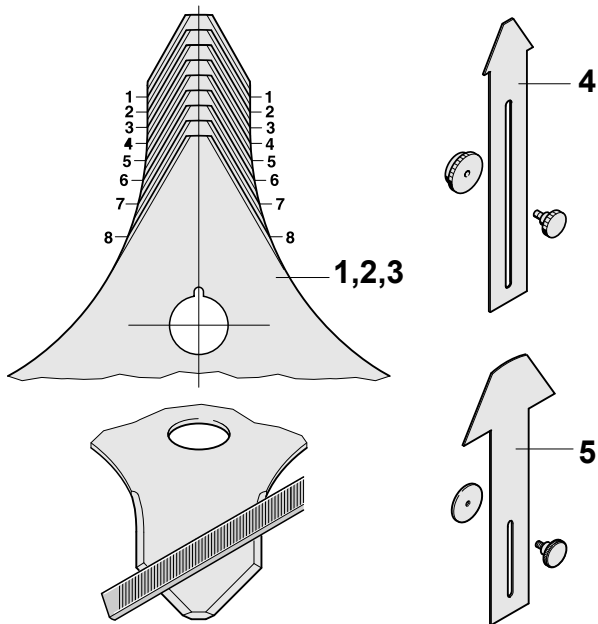

681KT337 KN

No.	Part number	Qty.	Designation
1	0457 342 2629	1	Sharpening instructions for brush knife 250-3 (B)
2	0457 342 2631	1	Sharpening instructions for brush knife 300-3 (B)
3	0457 342 2636	1	Sharpening instructions for brush knife 350-3 (B)
4	4020 890 5500	1	Sharpening template 250-3, 300-3, 350-3 (B)
5	4020 890 5501	1	Sharpening template 305-2 (B)

Balancer, Sharpening Instructions and Sharpening Tools

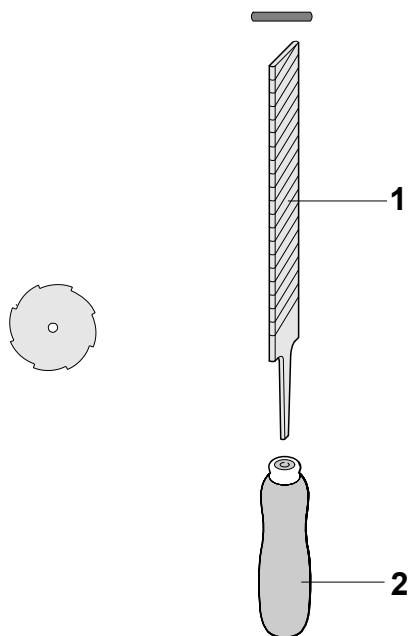

681KT942 KN

No.	Part number	Qty.	Designation
1	0814 212 3310	1	Flat file DIN7272-F 200-3
1	0814 212 3000	1	Flat file DIN7272-F 200-3 with case
2	0711 490 7860	1	File handle A100

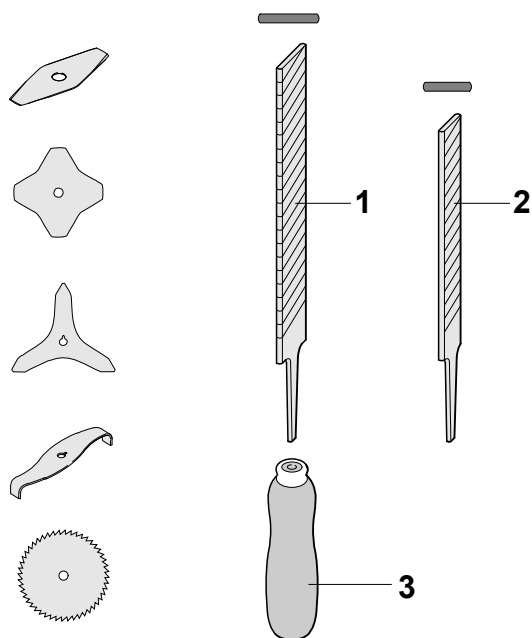

681KT599 KN

No.	Part number	Qty.	Designation
1	0814 252 3356	1	Flat file 150x16x2.7
2	0814 212 3310	1	Flat file DIN7272-F200-3
2	0814 212 3000	1	Flat file DIN7272-F 200-3 with case
3	0811 490 7860	1	File handle A100

Balancer, Sharpening Instructions and Sharpening Tools

No.	Part number	Qty.	Designation
1	5605 772 5506	1	Round file \varnothing 5.5 x 200 mm
2	0811 490 7860		File handle A100

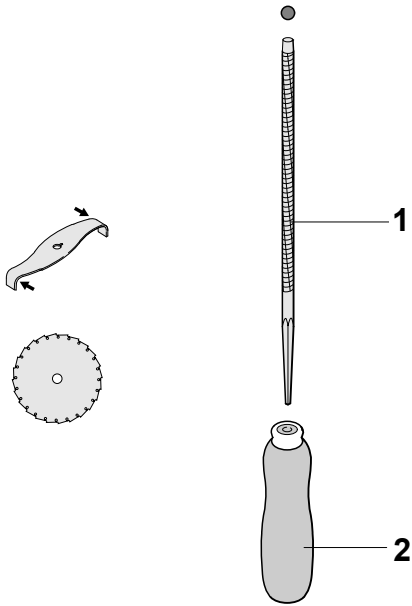

681KT940 KN

No.	Part number	Qty.	Designation
1	5605 750 4343	1	File holder Circular saw blade Chisel tooth <input type="checkbox"/> 2 - 5
2	5605 752 8300	1	Barrier bar
3	5605 752 7700	1	Nut
4	5605 772 5506	1	Round file \varnothing 5.5x200 mm
5	0811 490 7860	1	File handle A100
6	4020 893 5000		Saw set

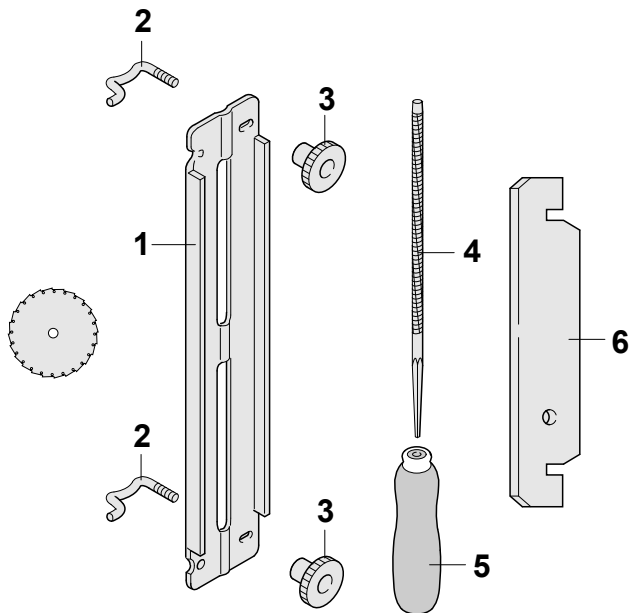

681KT941 KN

Balancer, Sharpening Instructions and Sharpening Tools

No.	Part number	Qty.	Designation
1	0811 421 8971	1	Three square file
2	0811 490 7860	1	File handle A100

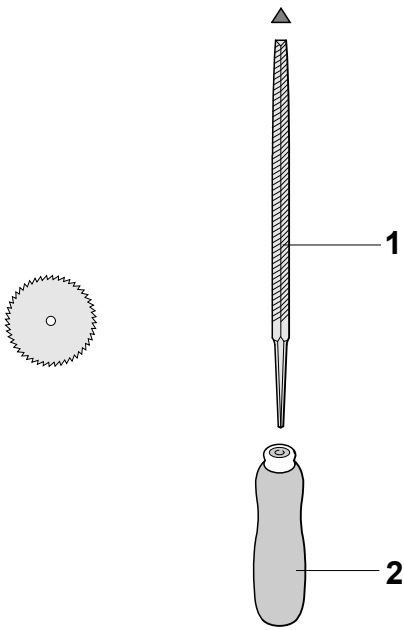

681KT943 KN

Transport guard for metal cutting attachments

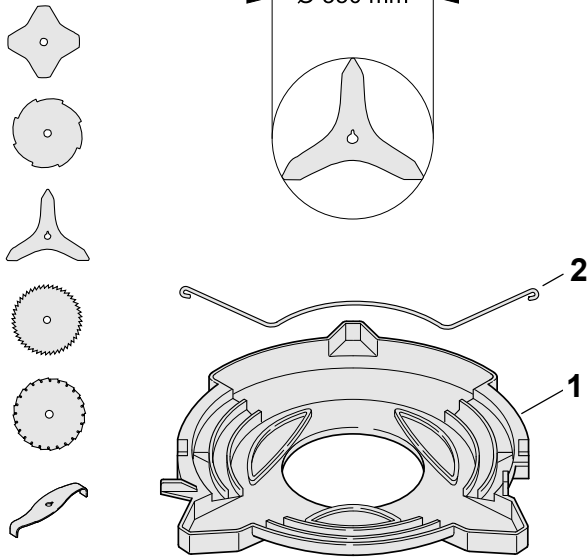

681KT100 KN

No.	Part number	Qty.	Designation
1	4116 790 3901	1	Transport guard Ø 350 □ 2
2	4116 792 4300	1	Retaining clip

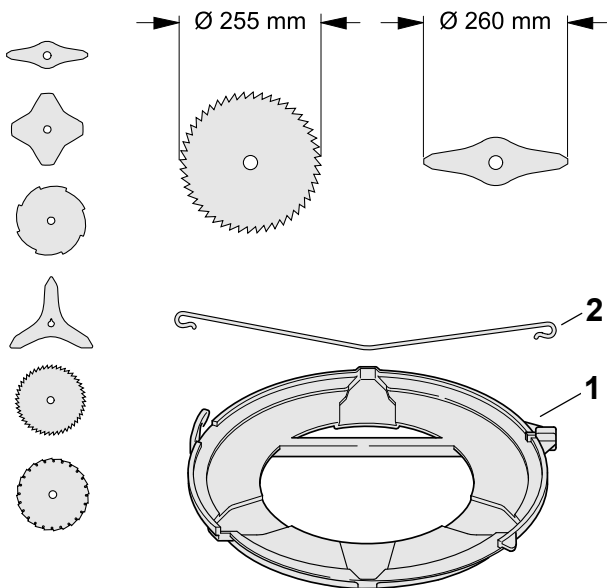

681KT709 KN

No.	Part number	Qty.	Designation
1	4119 790 3906	1	Transport guard Ø 260 □ 2
2	4119 792 4305	1	Retaining clip

Transport guard for metal cutting attachments

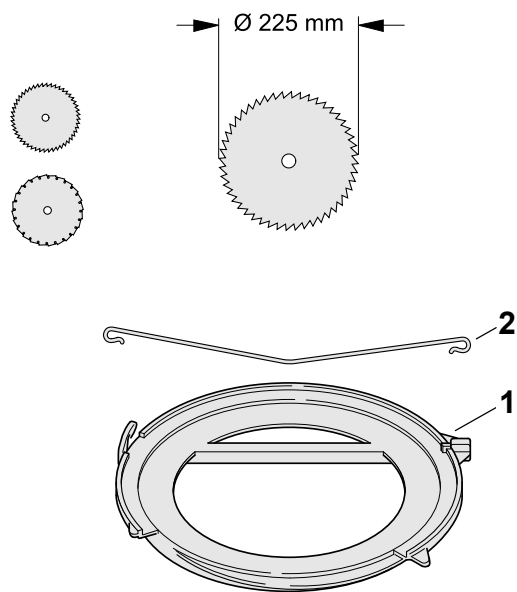

681KT702 KN

No.	Part number	Qty.	Designation
1	4119 790 3901	1	Transport guard Ø 225 □ 2
2	4119 792 4300	1	Retaining clip

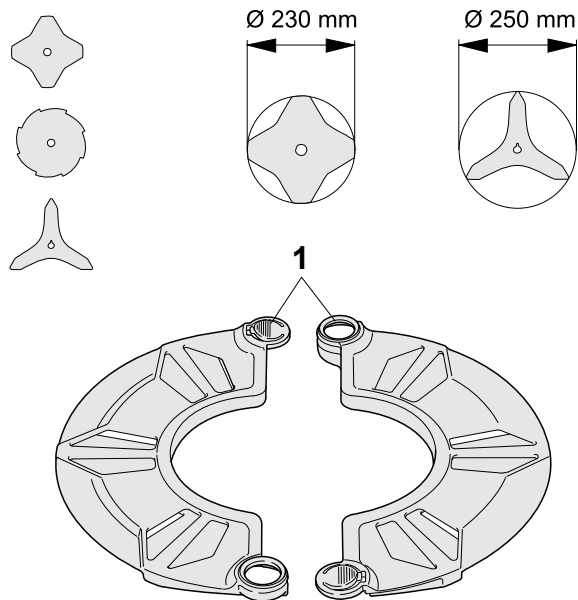

681KT982 KN

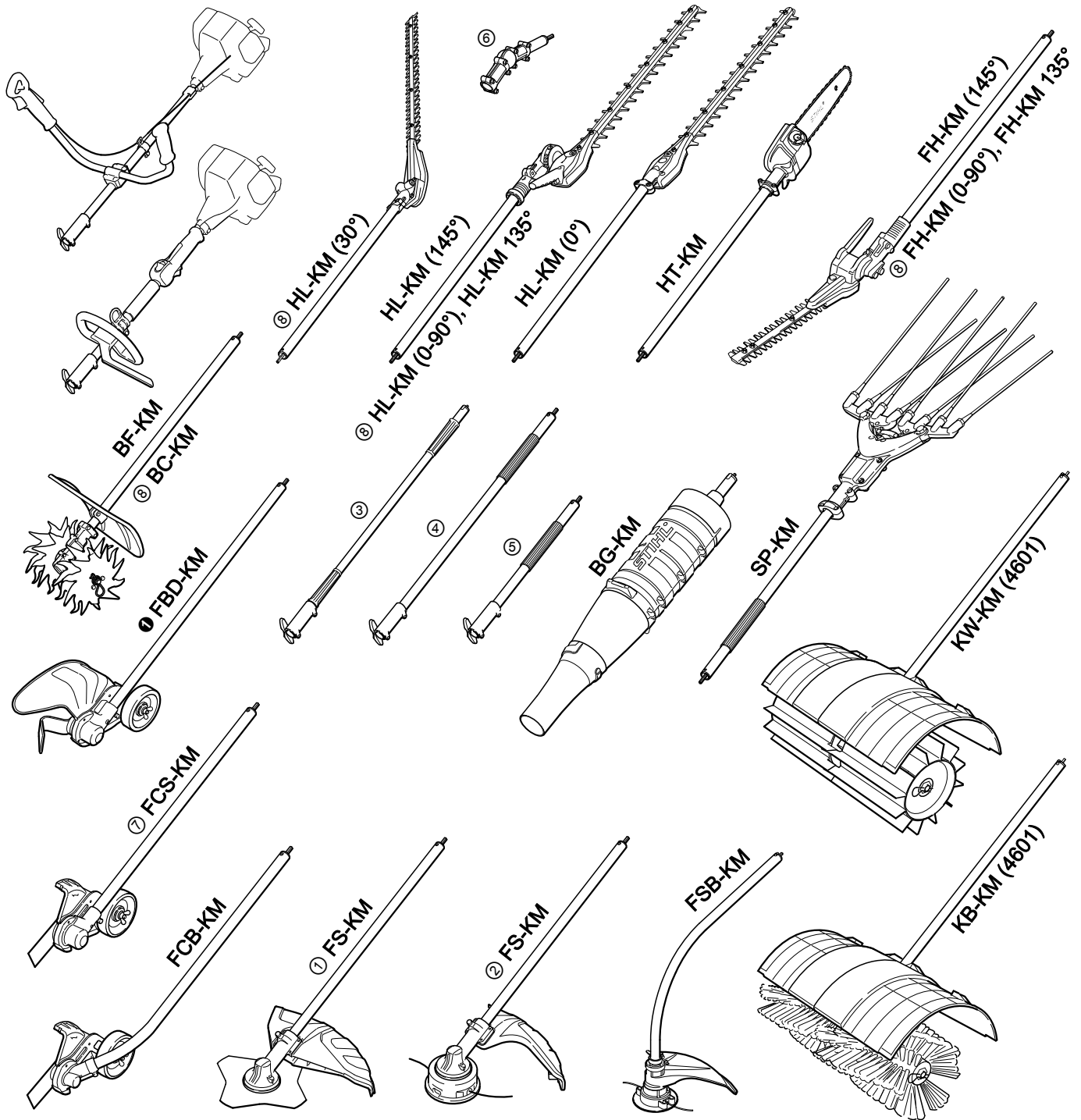

No.	Part number	Qty.	Designation
1	0000 790 3901	1	Transport guard

STIHL KombiTools

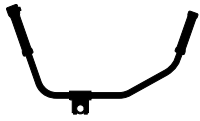

0000-GXX-3865-A0

STIHL KombiTools

Previous part name STIHL KombiTool (C)					BC-KM				FH-KM 0..90° 135°		HL-KM 30° 0-90° 135°			KW-KM (4602)			
STIHL KombiTool ● = approved ○ = limited ergonomic suitability — = not approved		FS-KM ①	FS-KM ②	FSB-KM	BF-KM	BG-KM	FCB-KM	FCS-KM	FH-KM 145°	HL-KM 0°	HL-KM 145°	HT-KM	KB-KM	KW-KM (4601)	SP-KM	FBD-KM	
KM 55		●	●	○	●	○	○	○	—	●	○	—	—	—	—	—	
KM 56		●	●	○	●	○	○	○	—	●	○	—	—	—	—	—	
KM 85		●	●	○	●	○	○	○	—	●	○	—	—	—	—	—	
KM 90		●	●	○	●	○	○	○	—	●	○	—	—	—	—	—	
KM 100		●	●	○	●	○	○	○	—	●	○	—	—	—	—	—	
KM 110		●	●	○	●	○	○	○	—	●	○	—	—	—	—	—	
KM 130		●	●	—	●	○	○	○	—	●	○	—	—	—	—	—	
KM 131		●	●	—	●	○	○	○	—	●	○	—	—	—	—	—	
KM 55 R		●	●	●	●	●	●	●	●	●	●	●	●	●	●	—	
KM 56 R		●	●	●	●	●	●	●	●	●	●	●	●	●	●	●	—
KM 85 R		●	●	●	●	●	●	●	●	●	●	●	●	●	●	●	—
KM 90 R		●	●	●	●	●	●	●	●	●	●	●	●	●	●	●	●
KM 91 R		●	●	●	●	●	●	●	●	●	●	●	●	●	●	●	●
KM 94 R		●	●	●	●	●	●	●	●	●	●	●	●	●	●	●	●
KM 100 R		●	●	●	●	●	●	●	●	●	●	●	●	●	●	●	●
KM 110 R		●	●	●	●	●	●	●	●	●	●	●	●	●	●	●	●
KM 111 R		●	●	●	●	●	●	●	●	●	●	●	●	●	●	●	●
KM 130 R		●	●	—	●	●	●	●	●	●	●	●	●	●	●	—	⑩
KM 131 R		●	●	—	●	●	●	●	●	●	●	●	●	●	●	—	●
KMA 130 R		●	●	—	●	●	●	●	●	●	●	●	●	●	●	●	●

① with grass cutting blade or brush knife

② with mowing head

③ drive tube extension (carbon fiber, 1 m): approved for HT-KM and HL-KM

④ drive tube extension (steel, 1 m): approved for HT-KM

⑤ drive tube extension (steel, 0.5 m): Approved for HT-KM, HL-KM and SP-KM

⑥ angle drive: approved for HT-KM and HL-KM 0°

⑦ only the FCS-KM with flexible drive shaft is approved for the KM 130 R with paper air filter and a cut-off speed of 9,500 rpm

⑧ no longer available

⑨ original sales designation

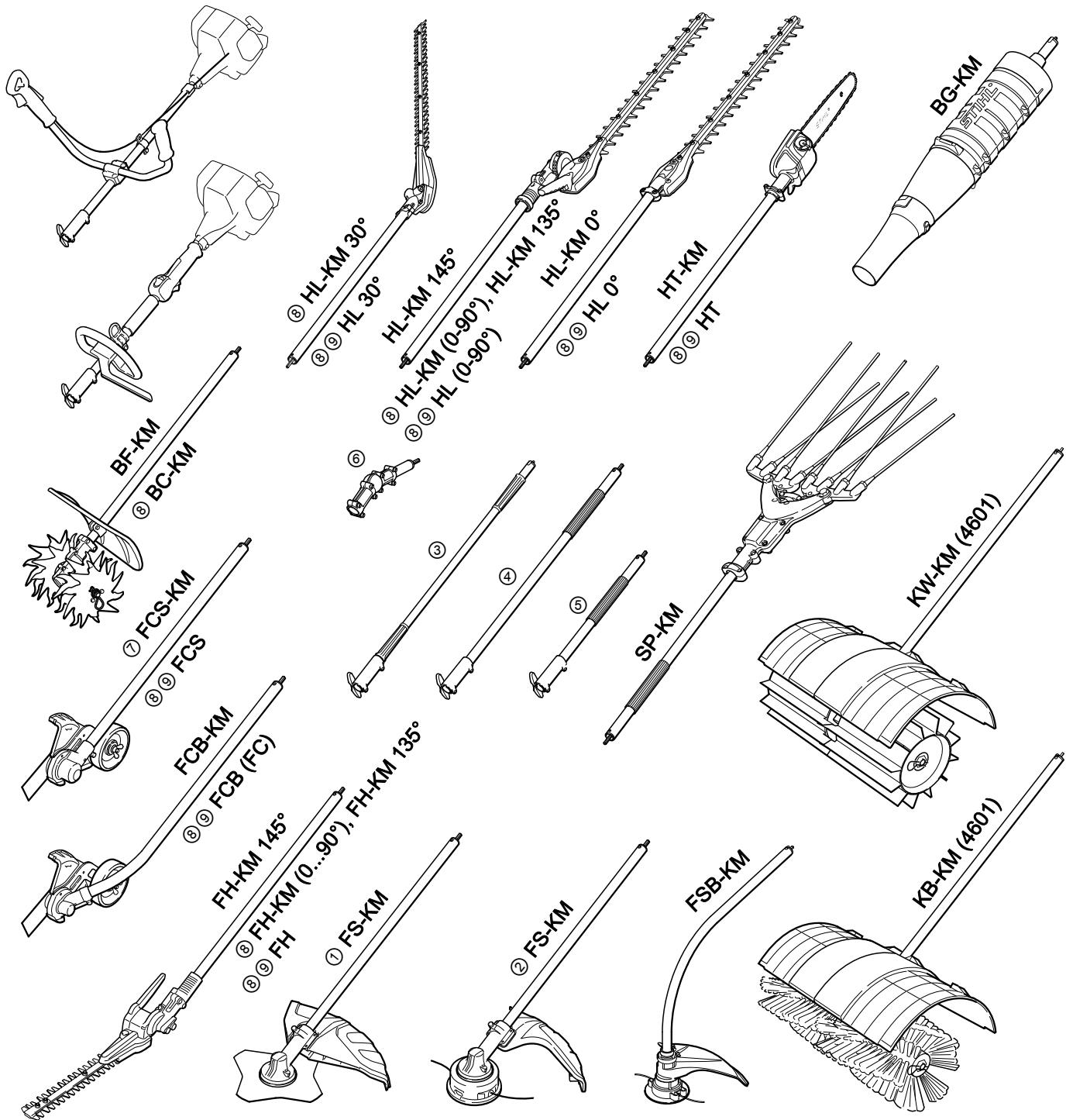

⑩ FBD-KM is approved only for the KM 130 R with paper air filter and a cut-off speed of 9,500 rpm

KombiTools for power tools with split drive tube



0000-GXX-3865-A0

KombiTools for power tools with split drive tube

Previous part name: STIHL interchangeable attachment (C)							FCS	(FC) FCB	FH	HL 0°	HL 30° 0..90°	HT		KW- (4602)		
Previous part name: STIHL KombiTool (C)				BC- KM					FH- KM 0..90° 135°		HL- KM 30° 0..90° 135°			KW- KM (4602)		
STIHL KombiTool		FS- KM ①	FS- KM ②	FSB- KM	BF- KM	BG- KM	FCS- KM	FCB- KM	FH- KM 145°	HL- KM 0°	HL- KM 145°	HT- KM	KB- KM	KW- KM (4601)	SP- KM	
● = approved ○ = limited ergonomic suitability — = not approved																
FS 55 T		●	●	○	●	○	○	○	●	—	○	—	—	—	—	—
FS 85 T		●	●	○	●	○	○	○	●	—	○	—	—	—	—	—
FS 55 RT		—	●	●	—	●	●	●	—	●	—	●	●	●	●	●
FS 85 RT		—	●	●	—	●	●	●	—	●	—	●	●	●	●	●
FR 85 RT		—	●	●	—	●	●	●	—	○	—	●	—	—	—	—
FR 130 T		—	●	●	●	●	●	●	●	○	●	●	—	—	—	—
FS 55 RT		●	●	●	●	●	●	●	●	●	●	●	●	●	●	●
FS 85 RT		●	●	●	●	●	●	●	●	●	●	●	●	●	●	●
FR 85 RT		●	●	●	●	●	●	●	●	●	○	●	●	—	—	—
FR 130 T		●	●	●	●	●	●	●	●	●	○	●	●	—	—	—
FR 131 T		●	●	●	●	●	●	●	●	○	●	●	—	—	—	—

① with grass cutting blade or brush knife

② with mowing head

③ drive tube extension (carbon fiber, 1 m): approved for HT-KM and HL-KM

④ drive tube extension (steel, 1 m): approved for HT-KM

⑤ drive tube extension (steel, 0.5 m): Approved for HT-KM, HL-KM and SP-KM

⑥ angle drive: approved for HT-KM and HL-KM 0°

⑦ only the FCS-KM with flexible drive shaft is approved for the KM 130 R with paper air filter and a cut-off speed of 9,500 rpm

⑧ no longer available

⑨ original sales designation

Attachments for STIHL power tools

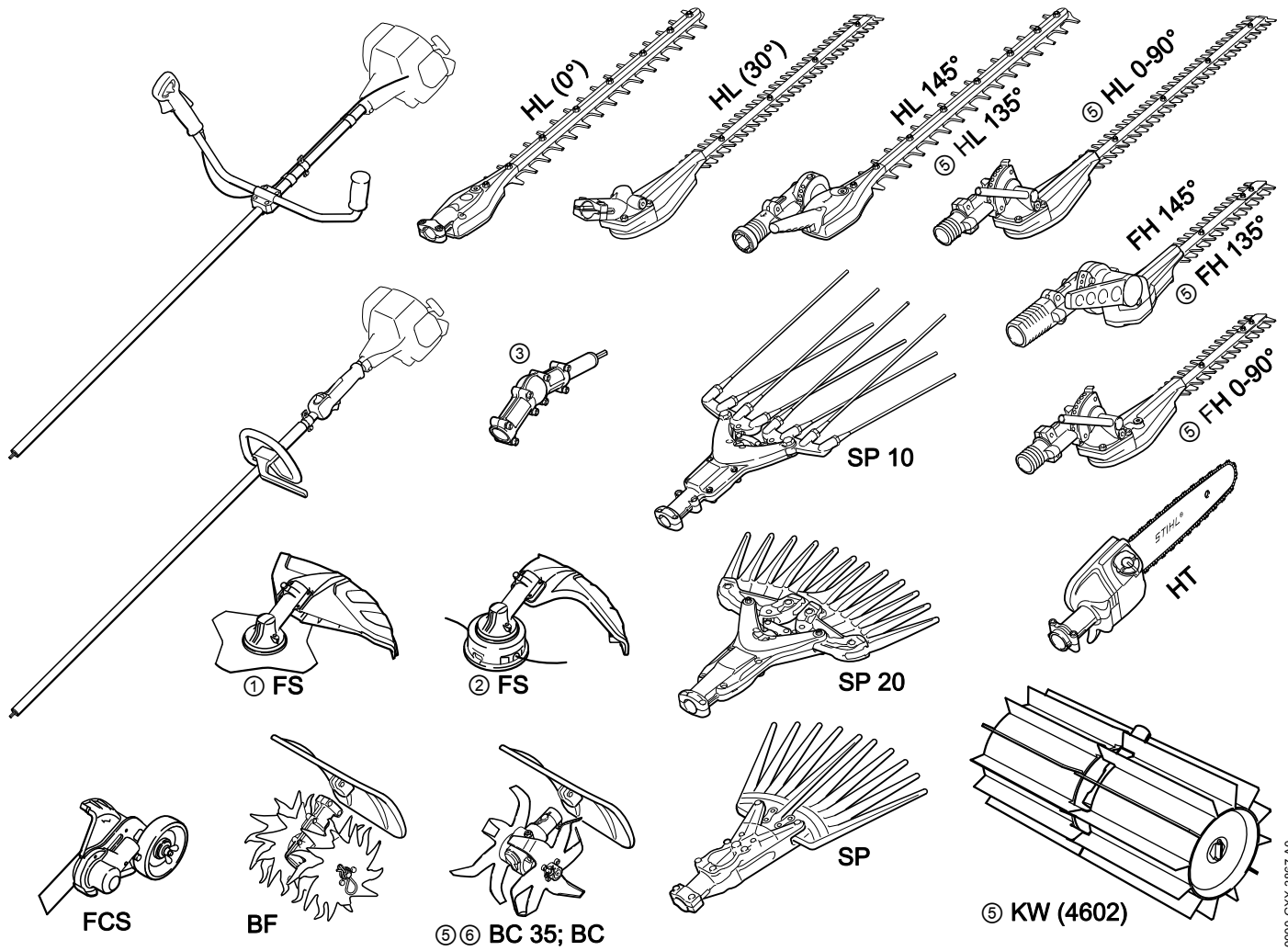

0000-GXX-3867-A0

Previous part name: Attachment (C)	BC 35 (BC)		FH 0-90° 135°	HL 0°	HL 30°	HL 0-90° 135°				KW (4602)			
STIHL attachments ● = approved ○ = limited ergonomic suitability — = not approved	BF	FCS	FH 145°	HL 0°		HL 145°	FS ①	FS ②	HT		SP	SP 10	SP 20
FS 85 ④	●	○	●	—	○	○	●	●	—	—	—	—	—
FS 90	●	○	●	—	○	○	●	●	—	—	—	—	—
FS 91	●	○	●	—	○	○	●	●	—	—	—	—	—
FS 100, 110	●	○	●	—	○	○	●	●	—	—	—	—	—
FS 111	●	○	●	—	○	○	●	●	—	—	—	—	—
FS 120, 200	●	—	—	—	—	—	●	●	—	—	—	—	—
FS 130	●	—	—	—	—	—	●	●	—	—	—	—	—
FS 131	●	—	—	—	—	—	●	●	—	—	—	—	—
FS 240, 250	●	—	—	—	—	—	●	●	—	—	—	—	—
KA 120	●	—	—	—	—	—	—	●	—	—	—	—	—

Attachments for STIHL power tools

Previous part name: Attachment (C)	BC 35 (BC)		FH 0-90° 135°	HL 0°	HL 30°	HL 0-90° 135°				KW (4602)			
STIHL attachments ● = approved ○ = limited ergonomic suitability — = not approved	BF	FCS	FH 145°	HL 0°		HL 145°	FS ①	FS ②	HT		SP	SP 10	SP 20
FC 95, 110	●	●	●	●	●	●	●	●	●	●	●	●	—
FC 111	●	●	●	●	●	●	●	●	●	●	●	●	—
FH 75	●	—	●	●	●	●	—	—	—	●	①	●	—
FR 85	●	●	●	●	●	●	●	●	●	—	①	●	—
FR 350, 410, 450	●	—	—	—	—	—	●	●	—	—	—	—	—
FR 460, 480	●	—	—	—	—	—	●	●	—	—	—	—	—
FS 85 R	●	●	●	●	●	●	●	●	●	●	①	●	—
FS 90 R	●	●	●	●	●	●	●	●	●	●	●	●	●
FS 91 R	●	●	●	●	●	●	●	●	●	●	●	●	●
FS 100 R, 110 R	②	②	②	②	②	②	②	②	②	②	②	②	②
FS 111 R	③	③	③	③	③	③	③	③	③	③	③	③	③
FS 120 R, 200 R	●	—	—	—	—	—	●	●	—	—	—	—	—
FS 130 R	●	—	—	—	—	●	●	●	●	—	●	—	—
FS 131 R	●	—	—	—	—	●	●	●	●	—	●	—	—
FS 240 R, 250 R	●	—	—	—	—	—	●	●	—	—	—	—	—
FT 100	—	—	—	—	—	—	—	—	●	—	—	—	—
HL 75	●	●	●	●	●	●	—	—	●	●	①	●	—
HL 75 K	—	—	—	●	●	●	—	—	—	—	①	●	—
HL 95, 100	●	●	●	●	●	●	—	—	●	●	●	●	—
HL 95 K, 100 K	—	—	—	●	●	●	—	—	—	—	●	●	—
KA 85 R	●	●	●	●	●	●	●	●	●	●	①	●	●
KA 120 R	●	●	●	●	●	●	●	●	●	●	①	●	●
KR 85	●	●	●	●	●	●	●	●	●	—	①	●	—
KW 85	●	—	●	●	●	●	—	—	—	●	—	—	—
SP 81	●	—	●	●	●	●	—	●	—	●	●	●	—



00964033 K

Attachments for STIHL power tools

Previous part name: Attachment (C)		BC 35 (BC)		FH 0-90° 135°	HL (0°)	HL 30°	HL 0-90° 135°				KW (4602)				
STIHL attachments ● = approved ○ = limited ergonomic suitability — = not approved		BF	FCS	FH 145°	HL 0°		HL 145°	FS ①	FS ②	HT		SP	SP 10	SP 20	
FC 95, 110		●	●	●	●	●	●	—	●	●	●	●	●	—	
FC 111		●	●	●	●	●	●	—	●	●	●	●	●	—	
FH 75		●	—	●	●	●	●	—	—	—	●	①	●	—	
FR 85		●	●	●	●	●	●	—	●	●	—	●	●	—	
FR 350, 410, 450		●	—	—	—	—	—	—	●	—	—	—	—	—	
FR 460, 480		●	—	—	—	—	—	—	●	—	—	—	—	—	
FS 85 R		●	●	●	●	●	●	—	●	●	●	●	①	●	—
FS 90 R		●	●	●	●	●	●	—	●	●	●	●	①	●	●
FS 91 R		●	●	●	●	●	●	—	●	●	●	●	①	●	●
FS 100 R, 110 R		②	②	②	②	②	②	—	②	②	②	②	②	②	●
FS 111 R		②	②	②	②	②	②	—	②	②	②	②	②	②	●
FS 120 R, 200 R		●	—	—	—	—	—	—	●	—	—	—	—	—	—
FS 130 R		●	—	—	—	—	—	●	—	●	●	—	●	—	●
FS 131 R		●	—	—	—	—	—	●	—	●	●	—	●	—	●
FS 240 R, 250 R		●	—	—	—	—	—	—	●	—	—	—	—	—	—
FT 100		—	—	—	—	—	—	—	—	—	●	—	—	—	—
HL 75		●	●	●	●	●	●	—	—	●	●	●	①	●	—
HL 75 K		—	—	—	●	●	●	—	—	—	—	—	①	●	—
HL 91 K		●	—	—	●	—	●	—	—	●	—	—	—	●	—
HL 92		●	—	—	●	—	●	—	—	●	—	—	—	—	—
HL 94		●	—	—	●	—	●	—	—	●	—	—	—	—	—
HL 95, 100		●	●	●	●	●	●	—	—	●	●	●	●	●	—
HL 95 K, 100 K		—	—	—	●	●	●	—	—	—	—	—	●	●	—
KA 85 R		●	●	●	●	●	●	—	●	●	●	●	①	●	●
KR 85		●	●	●	●	●	●	—	●	●	—	—	①	●	—
KW 85		●	—	●	●	●	●	—	—	—	—	●	①	●	—
SP 81	●	—	●	●	●	●	—	●	—	—	●	●	●	—	

002BA/02 K

Attachments for STIHL power tools

Previous part name: Attachment (C)		BC 35 (BC)		FH 0-90° 135°	HL 0°	HL 30°	HL 0-90° 135°				KW (4602)			
STIHL attachments ● = approved ○ = limited ergonomic suitability — = not approved		BF	FCS	FH 145°	HL 0°		HL 145°	FS ①	FS ②	HT		SP	SP 10	SP 20
HL 75		—	—	—	●	—	—	—	—	●	—	①	●	—
HL 75 K		—	—	—	●	—	—	—	—	—	—	①	●	—
HL 92 K		—	—	—	●	—	●	—	—	—	—	—	●	—
HL 94 K		—	—	—	●	—	●	—	—	—	—	—	●	—
HL 95, 100		—	—	—	●	—	—	—	—	●	—	●	●	—
HL 95, 100 K		—	—	—	●	—	—	—	—	—	—	●	●	—
HT 70		—	—	—	—	—	—	—	—	●	—	①	●	—
HT 75		—	—	—	●	—	—	—	—	●	—	—	—	—
HT 100		—	—	—	●	—	—	—	—	●	—	●	●	—
HT 130		—	—	—	—	②	—	—	—	—	●	—	●	—
HT 101, 131		—	—	—	—	—	—	—	—	—	●	—	—	—
SP 90		—	—	—	—	—	—	—	—	—	●	—	●	●
SP 92		—	—	—	—	—	—	—	—	—	—	—	●	●
SP 81		—	—	—	—	—	—	—	—	—	—	—	①	●

- ① with grass cutting blade or brush knife
- ② with mowing head
- ③ angle drive: approved for HT and HL 0° only
- ④ not approved for FS 85 from serial No. 1 49 709 301 bis 1 53 148 868 and FS 85 RX
- ⑤ no longer available
- ⑥ original sales designation
- ① approved only from serial No. 1 62 850 000, 2 63 970 000, 3 60 420 000
- ② not approved for FS 100 RX, 110 RX
- ③ not approved for FS 111 RX

MultiTools for STIHL MM 55, 56

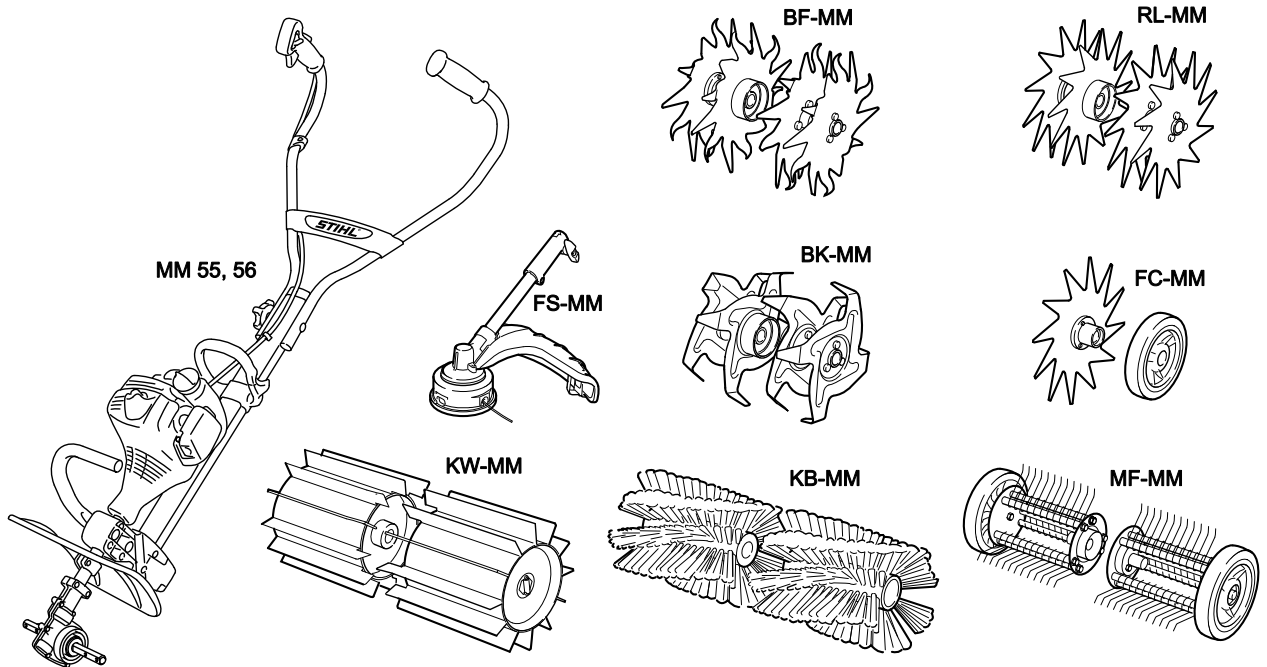

681KT882 KN

<ul style="list-style-type: none"> ● = approved ○ = limited ergonomic suitability — = not approved 		BF-MM	BK-MM	FC-MM	FS-MM	MF-MM	RL-MM	KB-MM	KW-MM
Gearbox orientation dependent on MultiTool		●	●	●	—	●	●	—	—
		—	—	—	—	—	—	●	●
		—	—	—	●	—	—	—	—

MultiTools for STIHL MM 55, 56

- = approved
- = limited ergonomic suitability
- = not approved

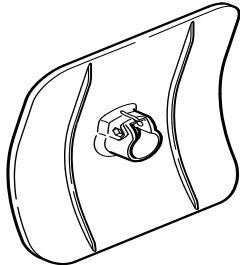
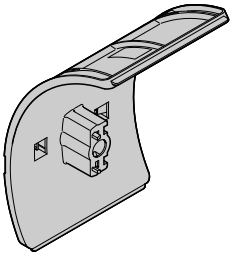
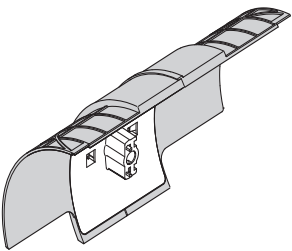
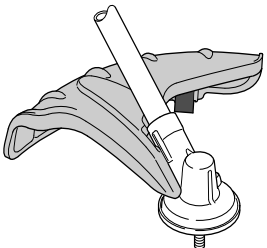
		BF-MM	BK-MM	FC-MM	FS-MM	MF-MM	RL-MM	KB-MM	KW-MM
Use of the deflector dependent on MultiTool	 4601 713 4500	●	●	●	—	—	●	—	●
	 4601 710 8100	●	●	●	—	—	●	—	●
	 4601 007 1009	—	—	—	—	●	—	●	●
	 4144 710 8117	—	—	—	●	—	—	—	—

Key to symbols:

- = including item No.
- = approved
- (•) = approved only for loop handle with barrier bar
- = not approved
- (A) = not illustrated
- (B) = only special accessory
- (C) = no longer available from factory
- (D) = not available as separate item
- ∅ = diameter