

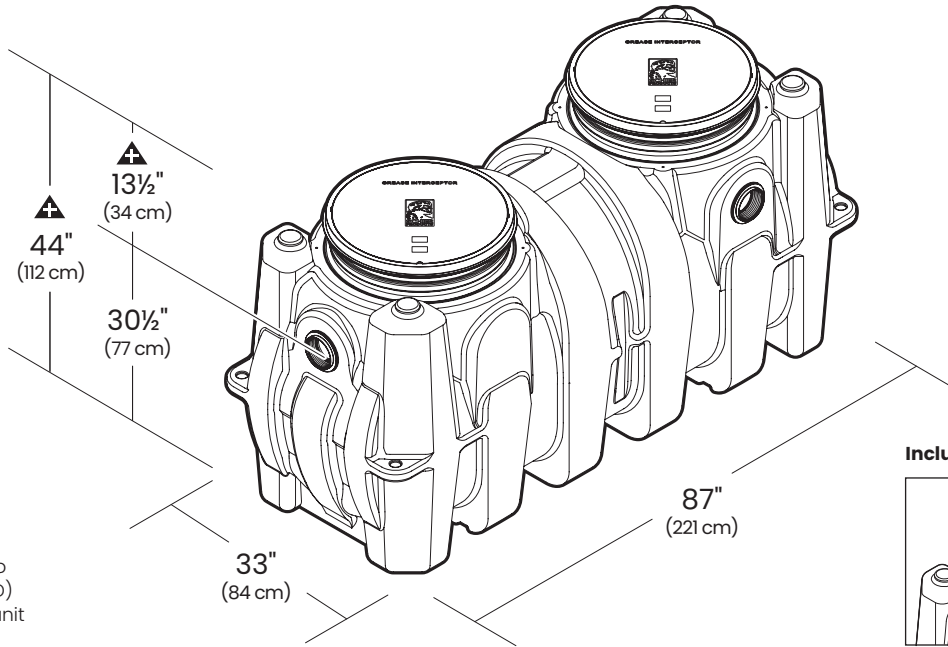

# SPECIFICATION AND SUBMITTAL

## GB-250 100/200 GPM Great Basin™ Indoor/Outdoor Grease Interceptor



▲ Adjustable cover adapters provide up to 4" of additional height.

 This unit is certified to ASME A112.14.3 (Type D) and CSA B481.1. This unit does not require flow control.

Includes Safety Star®

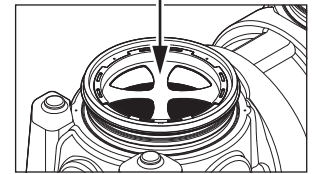

## SUBMITTAL

### Standard

**Location:** Indoor/outdoor  
**Installation:** Above/below grade  
**Flow Rates / Grease Capacities:**  
 100 GPM (6.3 L/s) / 1,895 lbs. (860 kg), 260 gal. (984 L)  
 200 GPM (12.6 L/s) / 1,196 lbs. (543 kg), 164 gal. (621 L)\*  
**Removal Efficiency at the Rated Capacity:** 96.7%  
**Solids Capacity:** 69 gal. (261 L)  
**Liquid Capacity:** 277 gal. (1,049 L)  
**Weight:** 376 lbs. (171 kg)  
**Connections:** 4" FPT with 4" plain end adapters, single inlet and triple outlet  
**Covers:** Cast iron covers, pickable 24" gas/water tight, H-20 rated, proof-load tested to 40,000 lbs.  
**Access Restrictor:** Safety Star® (450 lb. rating) built into each cover adapter

### Options

- 6" plain end inlet/outlet (straight-through) with dual pumpout port connections
- 6" MPT inlet/outlet (stainless steel, straight-through)
- FO (fixed outlet)
- C24H2 Composite covers, bolted 24" gas/water tight, traffic load rated for 16,000 lbs.

### Accessories

- FCR2 (x2) >4" - 34" field cut riser
- FCR2 (x4) >34" - 64" field cut risers
- FCR2 (x6) >64" - 94" field cut risers
- CA2 Adapter for 24" corrugated pipe riser
- PP3 Pumpout port
- AK1 High water anchor kit
- ATD1 Cover adapter tie-down kit
- AGS1 Above grade support kit
- PLAIN-EA-24 2" plain end fitting
- PLAIN-EA-34 3" plain end fitting
- FPT-EA-34 4" x 3" FPT fitting
- FPT-EA-23 3" x 2" FPT fitting
- CC2 Integral membrane clamping collar kit

\* At 200 GPM, this unit is certified to ASME A112.14.3 (Type C) and CSA B481.1 and includes an internal flow control. External flow control with vent not required.

## Approval

Signature:	Date:	Company:
Specifying Engineer:		Engineering Firm:



# SCHIER

**MODEL NUMBER:**  
GB-250

**DESCRIPTION:** 100/200 GPM Polyethylene Grease Interceptor

PART #: 4055-001-02

DWG BY: B. Karrer

DATE: 8/28/2020

REV:

ECO:



# SPECIAL PRECAUTIONS

For Schier Grease Interceptor Installations – Failure to follow this guidance voids your warranty

**WARNING!** DO NOT AIR TEST UNIT OR RISER SYSTEM!  
Doing so may result in property damage, personal injury or death.

**CAUTION!** Do not install this unit in any manner except as described in these instructions.

## Installation Instructions

Installation instructions and additional components are included with the interceptor. Read all instructions prior to installation. This interceptor is intended to be installed by a licensed plumber in conformance with all local codes.



**Install interceptor as close as possible to fixtures being served**

**Provide at least 16" clearance above unit for routine maintenance.**

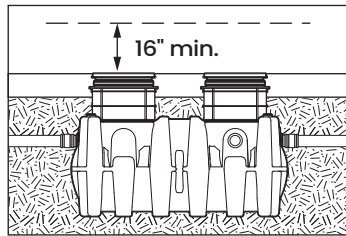

## High Temperature Kitchen Water

If water is entering the interceptor at excessive temperature (over 150° F), a drain water tempering valve (DTV) and approved backflow prevention assembly must be installed. Most state and local plumbing codes prohibit water above 150° F being discharged into the sanitary sewer. Water above 150° F will weaken or deform PVC Schedule 40 pipe, poly drainage fixtures like interceptors and erode the coating of cast iron (leading to eventual failure).

## ODOR ALERT!

Interceptor is not a sewer gas trap. All upstream fixtures must be trapped

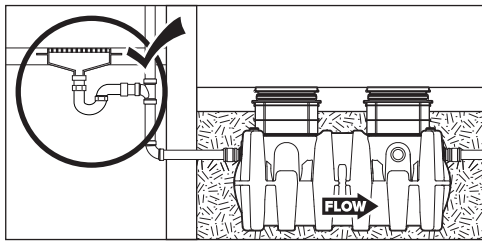

## ODOR ALERT!

Do not install air gap on outlet side of interceptor.

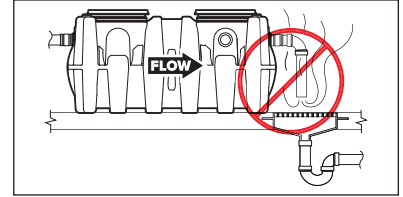

## Fully Support Base of Unit

Install unit on solid, level surface in contact with the entire footprint of unit base

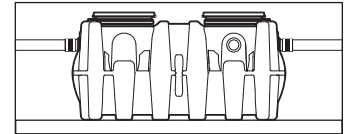

## Support Inlet and Outlet Piping

For above grade installations ensure heavy inlet and outlet piping (such as cast iron or long runs) is properly supported or suspended during the entire installation process to prevent connection failure or damage to bulkhead fittings.

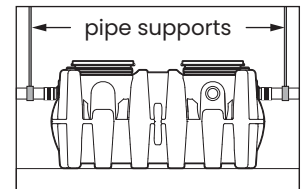

## Suspended Installations

Design trapeze to support the wet weight of the unit. Do not partially support unit or suspend unit using metal U-channel to create a trapeze. The wet weight of the interceptor combined with high temperature kitchen water creates the potential for tank deformation in suspended installations. In these situations Above Grade Support Kit model AGSI is required to be installed to maintain GB-250 structural integrity.

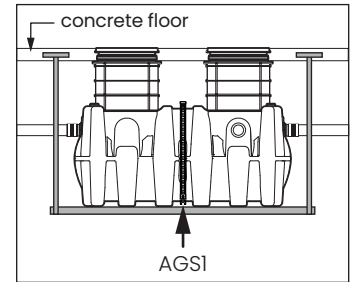

## DO NOT USE CAST IRON COVERS IN ABOVE GRADE OR INDOOR INSTALLATIONS

Use composite cover C24H2 for above grade installations

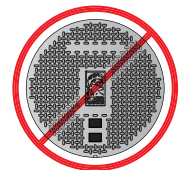

# SCHIER

MODEL NUMBER:  
**GB-250**

DESCRIPTION: 100/200 GPM Polyethylene Grease Interceptor

PART #: 4055-001-02

DWG BY: B. Karrer

DATE: 8/28/2020

REV:

ECO:



# SPECIAL PRECAUTIONS

For Schier Grease Interceptor Installations – Failure to follow this guidance voids your warranty

## Secure Cover Adapters

Cover adapters must be secured to base units in above grade installations with increased head pressure conditions. Use cover adapter tie-down kit model ATD1.

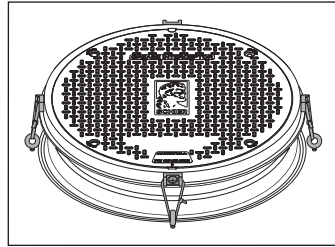

## High Water Table Installations

Interceptors and risers are not designed to withstand water table height in excess of the top of the unit when buried (see figure). If it is possible for this to occur, install the interceptor and risers in a water-tight concrete vault or backfill with concrete or flowable fill (wet concrete and flowable backfill should be poured in stages to avoid crushing the interceptor). At risk areas include but are not limited to tidal surge areas, floodplains and areas that receive storm water. Great Basin™ models that are direct buried in high water table scenarios must be installed with an anchor kit. Model GB-250 uses model AK1 anchor kit.

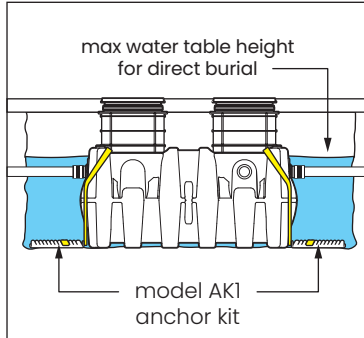

## Hydrostatic/ Pressure Slabs

When installed under a hydrostatic slab (slab designed to withstand upward lift, usually caused by hydrostatic pressure) interceptor must be enclosed in a watertight concrete vault.

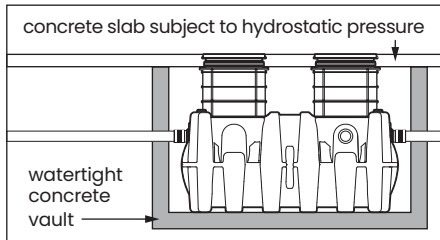

## DO NOT COMPACT BACKFILL MECHANICALLY

Compact by hand only

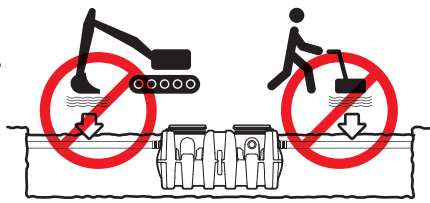

## Below Grade Installation Slab Requirements

A concrete slab to finished grade with rebar is required when installing interceptor below grade.

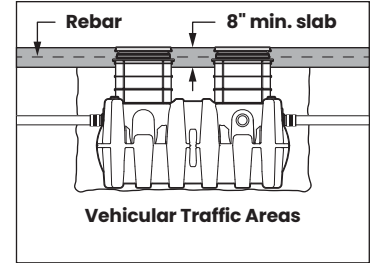
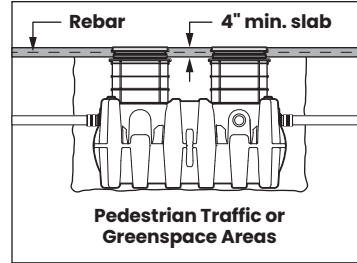

## Installations with Risers

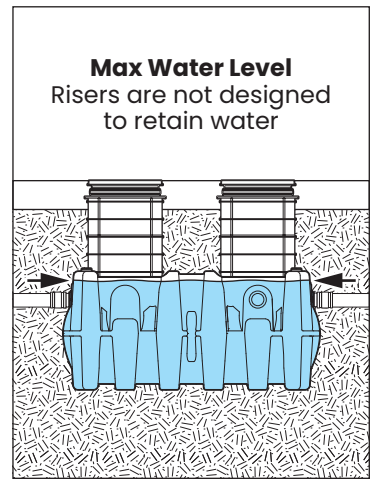
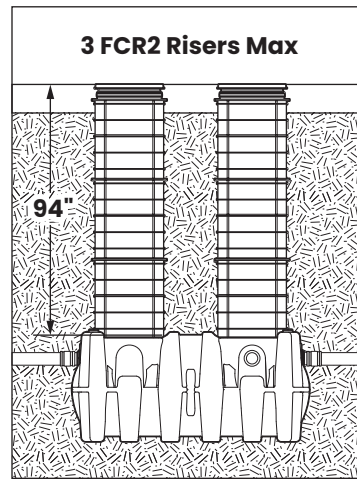

## Corrugated Riser Pipe Requirements

Riser adapter model CA2 must be used when installing interceptors using 24" diameter corrugated pipe as a riser. This will adequately embed the cover adapter in the concrete slab, preventing cover/cover adaption failure under traffic rated loads.

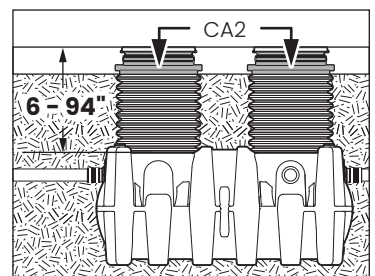

# SCHIER

MODEL NUMBER:  
**GB-250**

DESCRIPTION: 100/200 GPM Polyethylene Grease Interceptor

PART #: 4055-001-02

DWG BY: B. Karrer

DATE: 8/28/2020

REV:

ECO:

# SPECIFICATIONS

## NOTES

- 4" FPT with 4" plain end adapters, single inlet and triple outlet
- Unit weight - w/cast iron covers: 376 lbs.; w/composite covers: 266 lbs. (For wet weight add 2,310 lbs.)
- Maximum operating temperature: 150° F continuous
- Capacities - Liquid: 277 gal.; @100 GPM - Grease: 1,895 lbs. @200 GPM - Grease: 1,196 lbs. Solids: 69 gal.
- This unit does not require flow control for 100 GPM applications. Built-in Flow control is provided for 200 GPM applications. For series installations, only install flow control on the first unit in the series if necessary.
- For gravity drainage applications only.
- Do not use for pressure applications.
- Cover placement allows full access to tank for proper maintenance.
- Vent not required unless per local code.
- Engineered inlet and outlet diffusers are removable to inspect / clean piping.
- Integral air relief / Anti-siphon / Sampling access.
- Adjustable cover adapters provide up to 4" of additional height.
- Fixed outlet models (-FO) have inlet and outlet permanently welded at the factory in the straight-through (B) positions.
- Flow rates are based on 2-minute drain time.
- Safety Star®, access restrictor built into each cover adapter, prevents accidental entry to tanks (450 lb rating)

## DIFFUSION FLOW TECHNOLOGY

The inlet diffuser reduces turbulence, creates laminar flow and allows the entire tank volume to be utilized for efficient grease separation and minimal disturbance to existing grease and sediment layers. The inlet diffuser can be attached to any of the three inlets provided to ease job site piping layouts. The integral air relief / anti-siphon at the outlet diffuser top allows pressure stabilization within the unit during operation. The outlet diffuser can easily be attached to any of the three outlets provided to ease job site piping layouts.

## ENGINEER SPECIFICATION GUIDE

Schier Great Basin™ grease interceptor model # GB-250 shall be lifetime guaranteed and made in USA of seamless, rotationally-molded polyethylene. Interceptor shall be furnished for above or below grade installation. Interceptor shall be certified to ASME A112.14.3 (Type D for 100 GPM, type C for 200 GPM) and CSA B481.1, with adjustable cover adapters, Safety Star® access restrictor built into each cover adapter, built-in flow control (for 200 GPM only) and three outlet options. Interceptor flow rate shall be 100 or 200 GPM. Interceptor grease capacity shall be 1,895 lbs. @ 100 GPM or 1,196 GPM @ 200 GPM. Cover shall provide water/ gas-tight seal and have minimum 16,000 lbs. load capacity.

## CERTIFIED PERFORMANCE

Great Basin™ hydromechanical grease interceptors are third party performance-tested and listed by IAPMO to ASME #A112.14.3 and CSA B481.1 grease interceptor standards and greatly exceed requirements for grease separation and storage. They are compliant to the Uniform Plumbing Code and the International Plumbing Code.

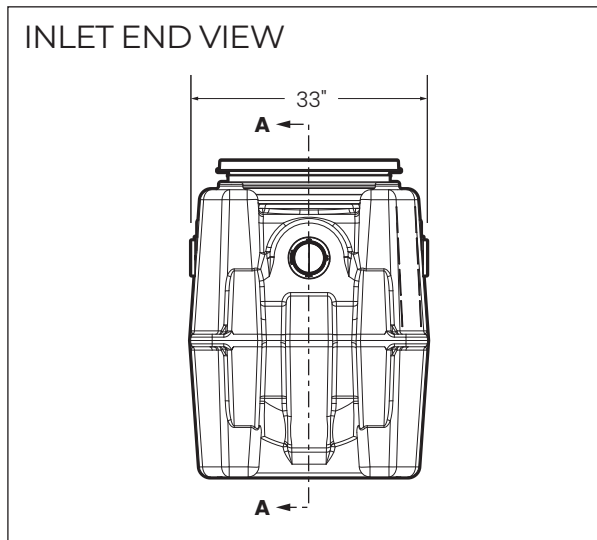
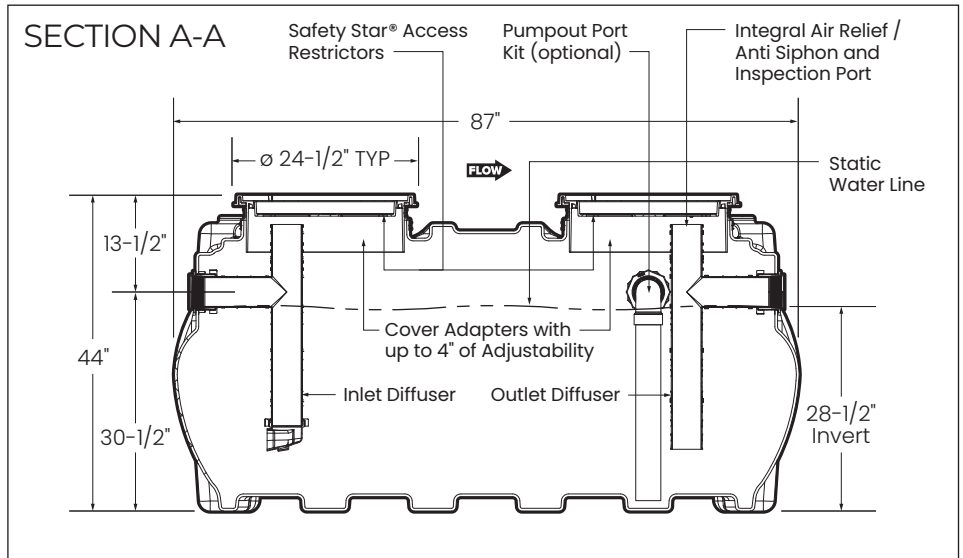
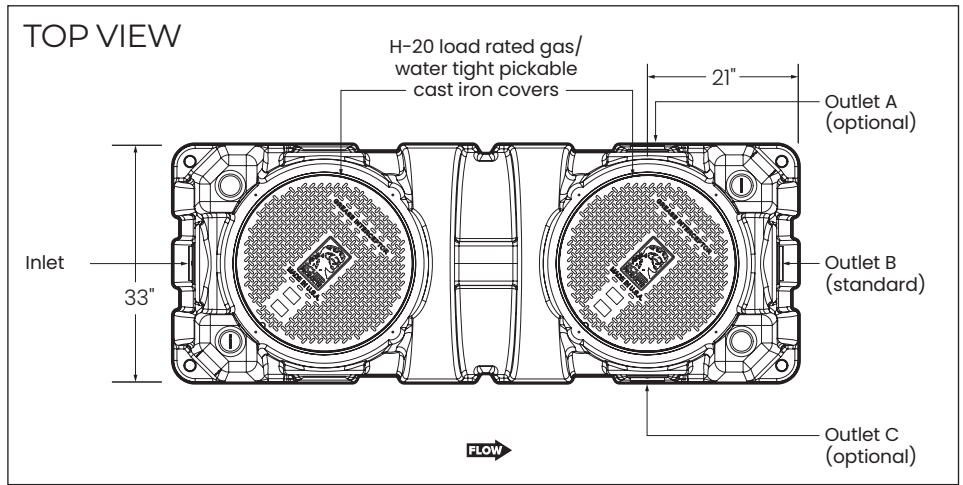

## Rated Grease Capacities for Units Piped in Series

No. of Units in Series	Removal Efficiency	
	100 GPM	200GPM
	96.7%	93.5%
2	3,790 lbs.	2,392 lbs.
3	5,685 lbs.	3,588 lbs.
4	7,580 lbs.	4,790 lbs.



# SCHIER

**MODEL NUMBER:**  
GB-250

**DESCRIPTION:** 100/200 GPM Polyethylene Grease Interceptor

PART #: 4055-001-02

DWG BY: B. Karrer

DATE: 8/28/2020

REV:

ECO: