



# PACKAGE GAS ELECTRIC UNITS

FORM NO. R11-837 REV. 4  
Supersedes Form No. R11-837 Rev. 3

## RKNA- SUPER HIGH EFFICIENCY SERIES NOMINAL SIZES 3-5 TONS [10.6-17.6 kW]





Engineering Features .....	3
Introduction .....	4
Selection Procedure .....	5
Model Identification Options .....	6-7
General Data	
RKNA- Series .....	8-25
General Data Notes .....	26
Performance Data	
RKNA- Series .....	27-28
Airflow Performance	
RKNA- Series .....	29-34
Electrical Data	
RKNA- Series .....	35-42
Dimensional Data .....	43-45
Accessories .....	46-54
Typical Wiring .....	55-61
Limited Warranty .....	64



## ENGINEERING FEATURES

RKNA- Series Package Gas Electric Units

1. All models feature Scroll® compressors offering maximum reliability, efficiency, and quiet operation.
2. Aluminized steel heat exchanger with in-shot burners helps eliminate corrosion. Stainless steel heat exchangers optional.
3. Integrated blower/burner control board with built-in diagnostic capability permits on-site trouble shooting.
4. One-piece top over the indoor section with drip lip, drawn painted base pan, and 1" [25.4 mm] raised flanges for supply/return air connections provides superior water management.
5. Convertible horizontal and vertical airflow design allows maximum field flexibility and minimizes inventory requirements.
6. Standard full perimeter forkable 14 gauge baserail with lifting holes for easier maneuvering and installations.
7. Factory installed one-inch [25.4 mm] throw away filter with provisions for two-inch [50.8 mm] filter.
8. Direct or belt drive options to accommodate a wide range of design conditions as high as 1.5 inches [.37 kPa] of external static pressure.
9. Easily removable filter, blower, gas heat, and compressor/control access panels permits prompt service.
10. Number and color coded wiring helps facilitate service and maintenance.
11. Common cabinet and components allows for installation flexibility and fewer parts to inventory.
12. Standard freezestat control offers evaporator coil freeze protection.
13. Factory or field installed high and low pressure controls.
14. Externally mounted refrigerant gauge ports for easy service diagnostics.
15. Side and base electric power and gas connection entry helps minimize roof penetrations.
16. Quick assembly common roof curbs helps save field labor and maximize size flexibility.
17. Easy to install, plug-in, slip-in, 100% fully modulating economizers.
18. Quality powder paint finish offers long lasting protection against extreme weather conditions and is able to withstand 1000 HR salt spray test.

[ ] Designates Metric Conversions

## These quality features are included in the Rheem Package Gas Electric Unit

### Evaporator Coil/Filter Access

- Return air filters, normally provided, are removed in this photo.



- Non-corrosive plastic condensate pan



### Tubular Heat Exchanger

- Aluminized steel (viewed from supply air side panel.)
- Stainless steel available

### Control Box Access



### Compressor Access (3 to 5 Ton [10.6 to 17.6 kW] Models)

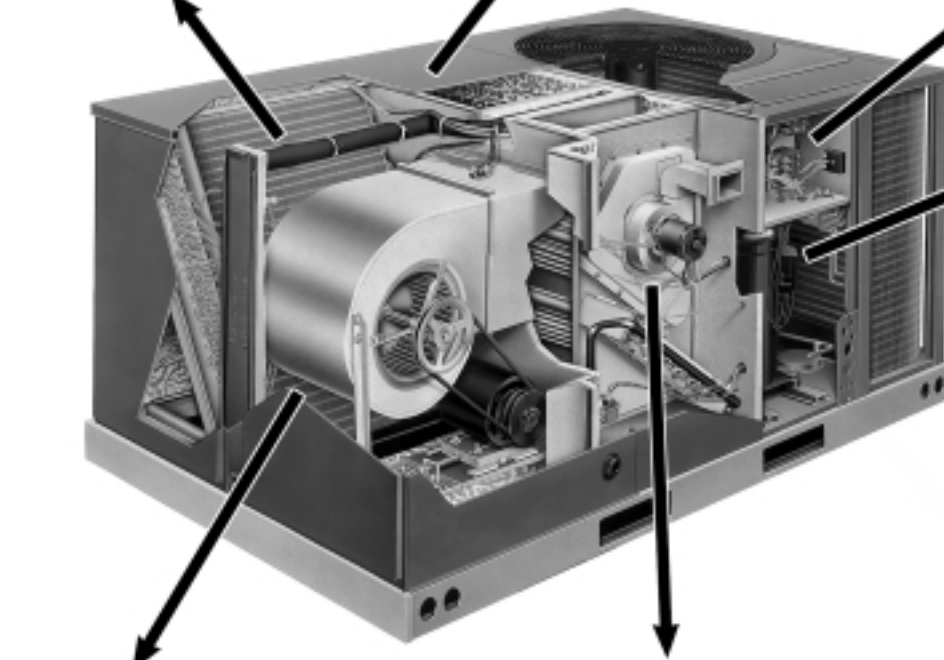

### Blower Access

- Belt drive model shown. (Available on 3-phase models only.)



### Heating Compartment Access

[ ] Designates Metric Conversions



# SELECTION PROCEDURE EXAMPLE—RKNA- SERIES

## 1. Determine cooling and heating requirements at design conditions.

Example:

Total cooling capacity .....	43,600 BTUH [12.78 kW]
Sensible cooling capacity .....	34,000 BTUH [9.96 kW]
Heating capacity .....	96,000 BTUH [28.13 kW]
Condenser entering air .....	95°F [35°C]
Evaporator entering air .....	63°F [17°C] wb/76°F [24°C] db
Indoor air flow .....	1600 CFM [755 L/s]
External static pressure.....	1.1 in wg
Required efficiency .....	13 SEER

## 2. Select unit to meet cooling requirements.

Since total cooling is within the range of 4 ton [14.07 kW] unit and requires 13 SEER efficiency level, enter cooling performance from the RKNA-A048 at 95°F [35°C] outdoor temperature, 63°F [17°C] wb entering indoor air, and 1550 CFM [732 L/s]:

Total capacity .....	47,300 BTUH [732 kW]
Power input .....	3.5 kW

And also, at 76°F [24°C] db indoor entering air, and using the formula at the bottom of the table:

Sensible capacity .....	41,708 BTUH [12.22 kW]
-------------------------	------------------------

## 3. Select heating capacity of the unit.

In the general data tables, note that the heating capacity of the 4 ton [14.07 kW] model with the 135,000 input heater can deliver 106,500 BTUH [31.21 kW], which is suitable for this application.

## 4. Determine blower speed and power to meet the system requirements.

At the given external static pressure of 1.1 in wg, the belt model must be selected. Enter the belt drive blower performance data at 1600 CFM [755 L/s] and 1.1 in wg ESP:

RPM .....	1195
Watts.....	755
Drive .....	M

## 5. Calculate indoor blower BTUH heat effect.

$$\text{BTUH} = \text{Watts} \times 3.413 = 2577$$

## 6. Calculate net cooling capacities.

$$\text{Net total cooling} = 47,300 - 2577 = 44,723 \text{ BTUH [13.10 kW]}$$

$$\text{Net sensible cooling} = 41,708 - 2577 = 39,131 \text{ BTUH [11.47 kW]}$$

[ ] Designates Metric Conversions

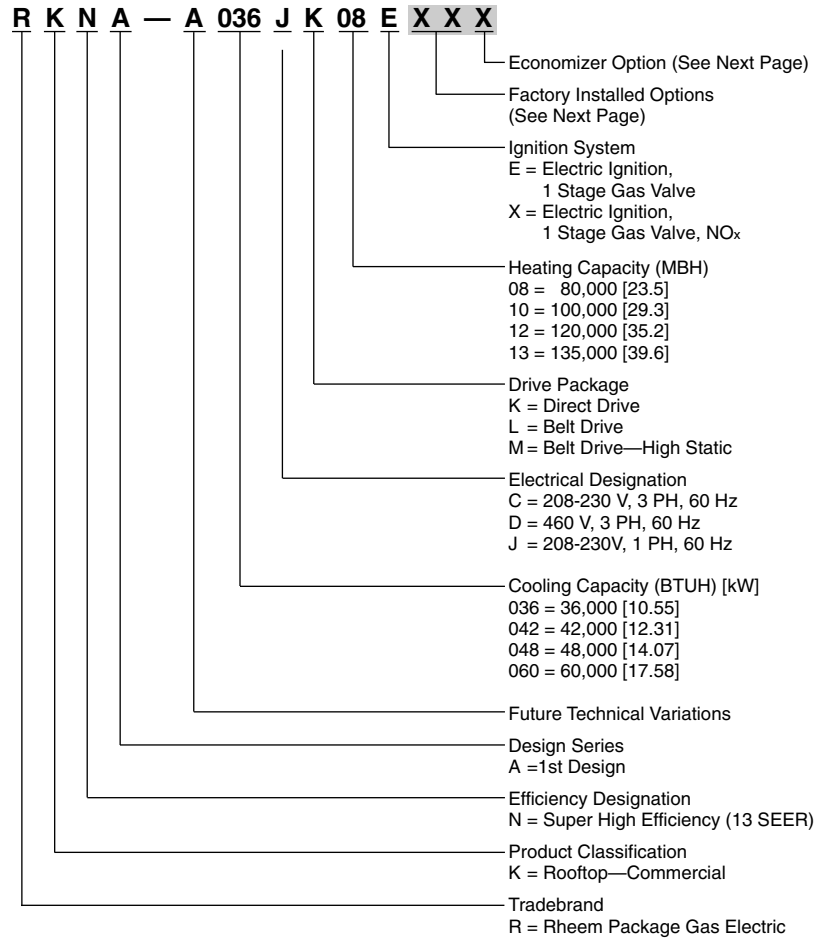

[ ] Designates Metric Conversions



**FACTORY INSTALLED OPTION CODES FOR RKNA (3-5 TON) [10.6-17.6 kW]  
(A036, A042, A048, A060)**

Option Code	High and Low Pressure	Hail Guard	Low Ambient Time Delay	Unwired Convenience Outlet Unfused Service Disconnect	Stainless Steel Heat Exchanger	Side Flow	Reduced Height Baseraills
AA	No Options						
AC	x						
AD		x					
AE			x				
AH				x			
AJ					x		
AK						x	
AL							x
BB	x	x					
BE	x		x				
BF		x		x			
BG		x			x		
BH			x	x			
BS		x				x	
BU	x					x	
BV					x	x	
BX		x					x
CA	x	x			x		
CB	x	x	x				
CE	x	x				x	
CP	x	x					x
DA	x	x	x	x			
DB	x	x	x		x		
EB	x	x	x	x	x		

**Economizer Codes**

A = No Economizer

B = Economizer with Single Enthalpy

Example: RKNA-A060JK13E**XXX** (where **XX** is factory installed option)

Example: No Options

RKNA-A060JK13E

Example: No option with factory installed economizer

RKNA-A060JK13EAAB

Example: Options with stainless steel heat exchanger and no factory installed economizer

RKNA-A060JK13EAJA

Example: Options same as above with factory installed economizer

RKNA-A060JK13EAJB

[ ] Designates Metric Conversions



## NOM. SIZES 3-5 TONS [10.6-17.6 kW]

Model RKNA- Series	A036CK08E	A036CK12E	A036CL08E	A036CL12E
<b>Cooling Performance<sup>1</sup></b>				
Gross Cooling Capacity Btu [kW]	37,400 [10.96]	37,400 [10.96]	37,400 [10.96]	37,400 [10.96]
EER/SEER <sup>2</sup>	11.7/13	11.7/13	11.7/13	11.7/13
Nominal CFM/ARI Rated CFM [L/s]	1200/1200 [566/566]	1200/1200 [566/566]	1200/1200 [566/566]	1200/1200 [566/566]
ARI Net Cooling Capacity Btu [kW]	36,000 [10.55]	36,000 [10.55]	36,000 [10.55]	36,000 [10.55]
Net Sensible Capacity Btu [kW]	26,400 [7.74]	26,400 [7.74]	26,400 [7.74]	26,400 [7.74]
Net Latent Capacity Btu [kW]	9,600 [2.81]	9,600 [2.81]	9,600 [2.81]	9,600 [2.81]
Net System Power kW	3.08	3.08	3.08	3.08
<b>Heating Performance (Package Gas/Electric)<sup>3</sup></b>				
Heating Input Btu [kW]	80,000 [23.44]	120,000 [35.16]	80,000 [23.44]	120,000 [35.16]
Heating Output Btu [kW]	64,800 [18.99]	97,200 [28.48]	64,800 [18.99]	97,200 [28.48]
Temperature Rise Range °F [°C]	30-60 [16.7/33.3]	50-80 [27.8/44.4]	30-60 [16.7/33.3]	50-80 [27.8/44.4]
AFUE %	80	80	80	80
Steady State Efficiency (%)	81	81	81	81
No. Burners	4	6	4	6
No. Stages	1	1	1	1
Gas Connection Pipe Size in. [mm]	0.5 [12.7]	0.5 [12.7]	0.5 [12.7]	0.5 [12.7]
<b>Compressor</b>				
No./Type	1/Scroll	1/Scroll	1/Scroll	1/Scroll
<b>Outdoor Sound Rating (dB)</b>				
	78	78	78	78
<b>Outdoor Coil—Fin Type</b>				
Tube Type	Louvered	Louvered	Louvered	Louvered
Tube Size in. [mm] OD	Rifled	Rifled	Rifled	Rifled
Tube Size in. [mm] OD	0.375 [9.5]	0.375 [9.5]	0.375 [9.5]	0.375 [9.5]
Face Area sq. ft. [sq. m]	16.91 [1.57]	16.91 [1.57]	16.91 [1.57]	16.91 [1.57]
Rows / FPI [FPcm]	1 / 22 [9]	1 / 22 [9]	1 / 22 [9]	1 / 22 [9]
<b>Indoor Coil—Fin Type</b>				
Tube Type	Corrugated	Corrugated	Corrugated	Corrugated
Tube Type	Rifled	Rifled	Rifled	Rifled
Tube Size in. [mm]	0.375 [9.5]	0.375 [9.5]	0.375 [9.5]	0.375 [9.5]
Face Area sq. ft. [sq. m]	5.17 [0.48]	5.17 [0.48]	5.17 [0.48]	5.17 [0.48]
Rows / FPI [FPcm]	2 / 17 [7]	2 / 17 [7]	2 / 17 [7]	2 / 17 [7]
Refrigerant Control	TX Valves	TX Valves	TX Valves	TX Valves
Drain Connection No./Size in. [mm]	1/0.75 [19.05]	1/0.75 [19.05]	1/0.75 [19.05]	1/0.75 [19.05]
<b>Outdoor Fan—Type</b>				
Type	Propeller	Propeller	Propeller	Propeller
No. Used/Diameter in. [mm]	1/24 [609.6]	1/24 [609.6]	1/24 [609.6]	1/24 [609.6]
Drive Type/No. Speeds	Direct/1	Direct/1	Direct/1	Direct/1
CFM [L/s]	3680 [1737]	3680 [1737]	3680 [1737]	3680 [1737]
No. Motors/HP	1 at 1/3 HP	1 at 1/3 HP	1 at 1/3 HP	1 at 1/3 HP
Motor RPM	1075	1075	1075	1075
<b>Indoor Fan—Type</b>				
Type	FC Centrifugal	FC Centrifugal	FC Centrifugal	FC Centrifugal
No. Used/Diameter in. [mm]	1/10x10 [254x254]	1/10x10 [254x254]	1/10x10 [254x254]	1/10x10 [254x254]
Drive Type/No. Speeds	Direct/3	Direct/3	Belt/Variable	Belt/Variable
No. Motors	1	1	1	1
Motor HP	1/2	1/2	1/2	1/2
Motor RPM	1075	1075	1725	1725
Motor Frame Size	48	48	48	48
<b>Filter—Type</b>				
Type	Disposable	Disposable	Disposable	Disposable
Furnished	Yes	Yes	Yes	Yes
(No.) Size Recommended in. [mm]	(1)1x16x25 [25x406x635]	(1)1x16x25 [25x406x635]	(1)1x16x25 [25x406x635]	(1)1x16x25 [25x406x635]
	(1)1x16x25 [25x406x635]	(1)1x16x25 [25x406x635]	(1)1x16x25 [25x406x635]	(1)1x16x25 [25x406x635]
<b>Refrigerant Charge Oz. [g]</b>				
	93 [2637]	93 [2637]	93 [2637]	93 [2637]
<b>Weights</b>				
Net Weight lbs. [kg]	543 [246]	543 [246]	543 [246]	543 [246]
Ship Weight lbs. [kg]	550 [249]	550 [249]	550 [249]	550 [249]

**CONTINUED** →

See Page 26 for Notes.

[ ] Designates Metric Conversions



## NOM. SIZES 3-5 TONS [10.6-17.6 kW]

Model RKNA- Series	A036CM08E	A036CM12E	A036DK08E	A036DK12E
<b>Cooling Performance<sup>1</sup></b>				
Gross Cooling Capacity Btu [kW]	37,400 [10.96]	37,400 [10.96]	37,400 [10.96]	37,400 [10.96]
EER/SEER <sup>2</sup>	11.7/13	11.7/13	11.7/13	11.7/13
Nominal CFM/ARI Rated CFM [L/s]	1200/1200 [566/566]	1200/1200 [566/566]	1200/1200 [566/566]	1200/1200 [566/566]
ARI Net Cooling Capacity Btu [kW]	36,000 [10.55]	36,000 [10.55]	36,000 [10.55]	36,000 [10.55]
Net Sensible Capacity Btu [kW]	26,400 [7.74]	26,400 [7.74]	26,400 [7.74]	26,400 [7.74]
Net Latent Capacity Btu [kW]	9,600 [2.81]	9,600 [2.81]	9,600 [2.81]	9,600 [2.81]
Net System Power kW	3.08	3.08	3.08	3.08
<b>Heating Performance (Package Gas/Electric)<sup>3</sup></b>				
Heating Input Btu [kW]	80,000 [23.44]	120,000 [35.16]	80,000 [23.44]	120,000 [35.16]
Heating Output Btu [kW]	64,800 [18.99]	97,200 [28.48]	64,800 [18.99]	97,200 [28.48]
Temperature Rise Range °F [°C]	30-60 [16.7/33.3]	50-80 [27.8/44.4]	30-60 [16.7/33.3]	50-80 [27.8/44.4]
AFUE %	80	80	80	80
Steady State Efficiency (%)	81	81	81	81
No. Burners	4	6	4	6
No. Stages	1	1	1	1
Gas Connection Pipe Size in. [mm]	0.5 [12.7]	0.5 [12.7]	0.5 [12.7]	0.5 [12.7]
<b>Compressor</b>				
No./Type	1/Scroll	1/Scroll	1/Scroll	1/Scroll
<b>Outdoor Sound Rating (dB)</b>				
	78	78	78	78
<b>Outdoor Coil—Fin Type</b>				
Tube Type	Louvered	Louvered	Louvered	Louvered
Tube Size in. [mm] OD	Rifled	Rifled	Rifled	Rifled
Tube Size in. [mm] OD	0.375 [9.5]	0.375 [9.5]	0.375 [9.5]	0.375 [9.5]
Face Area sq. ft. [sq. m]	16.91 [1.57]	16.91 [1.57]	16.91 [1.57]	16.91 [1.57]
Rows / FPI [FPcm]	1 / 22 [9]	1 / 22 [9]	1 / 22 [9]	1 / 22 [9]
<b>Indoor Coil—Fin Type</b>				
Tube Type	Corrugated	Corrugated	Corrugated	Corrugated
Tube Type	Rifled	Rifled	Rifled	Rifled
Tube Size in. [mm]	0.375 [9.5]	0.375 [9.5]	0.375 [9.5]	0.375 [9.5]
Face Area sq. ft. [sq. m]	5.17 [0.48]	5.17 [0.48]	5.17 [0.48]	5.17 [0.48]
Rows / FPI [FPcm]	2 / 17 [7]	2 / 17 [7]	2 / 17 [7]	2 / 17 [7]
Refrigerant Control	TX Valves	TX Valves	TX Valves	TX Valves
Drain Connection No./Size in. [mm]	1/0.75 [19.05]	1/0.75 [19.05]	1/0.75 [19.05]	1/0.75 [19.05]
<b>Outdoor Fan—Type</b>				
Propeller	Propeller	Propeller	Propeller	Propeller
No. Used/Diameter in. [mm]	1/24 [609.6]	1/24 [609.6]	1/24 [609.6]	1/24 [609.6]
Drive Type/No. Speeds	Direct/1	Direct/1	Direct/1	Direct/1
CFM [L/s]	3680 [1737]	3680 [1737]	3680 [1737]	3680 [1737]
No. Motors/HP	1 at 1/3 HP	1 at 1/3 HP	1 at 1/3 HP	1 at 1/3 HP
Motor RPM	1075	1075	1075	1075
<b>Indoor Fan—Type</b>				
FC Centrifugal	FC Centrifugal	FC Centrifugal	FC Centrifugal	FC Centrifugal
No. Used/Diameter in. [mm]	1/10x10 [254x254]	1/10x10 [254x254]	1/10x10 [254x254]	1/10x10 [254x254]
Drive Type/No. Speeds	Belt/Variable	Belt/Variable	Direct/3	Direct/3
No. Motors	1	1	1	1
Motor HP	1/2	1/2	1/2	1/2
Motor RPM	1725	1725	1075	1075
Motor Frame Size	48	48	48	48
<b>Filter—Type</b>				
Disposable	Disposable	Disposable	Disposable	Disposable
Furnished	Yes	Yes	Yes	Yes
(No.) Size Recommended in. [mm]	(1)1x16x25 [25x406x635]	(1)1x16x25 [25x406x635]	(1)1x16x25 [25x406x635]	(1)1x16x25 [25x406x635]
	(1)1x16x25 [25x406x635]	(1)1x16x25 [25x406x635]	(1)1x16x25 [25x406x635]	(1)1x16x25 [25x406x635]
<b>Refrigerant Charge Oz. [g]</b>				
	93 [2637]	93 [2637]	93 [2637]	93 [2637]
<b>Weights</b>				
Net Weight lbs. [kg]	543 [246]	543 [246]	543 [246]	543 [246]
Ship Weight lbs. [kg]	550 [249]	550 [249]	550 [249]	550 [249]

**CONTINUED** →

See Page 26 for Notes.

[ ] Designates Metric Conversions



## NOM. SIZES 3-5 TONS [10.6-17.6 kW]

Model RKNA- Series	A036DL08E	A036DL12E	A036DM08E	A036DM12E
<b>Cooling Performance<sup>1</sup></b>				<b>CONTINUED</b> →
Gross Cooling Capacity Btu [kW]	37,400 [10.96]	37,400 [10.96]	37,400 [10.96]	37,400 [10.96]
EER/SEER <sup>2</sup>	11.7/13	11.7/13	11.7/13	11.7/13
Nominal CFM/ARI Rated CFM [L/s]	1200/1200 [566/566]	1200/1200 [566/566]	1200/1200 [566/566]	1200/1200 [566/566]
ARI Net Cooling Capacity Btu [kW]	36,000 [10.55]	36,000 [10.55]	36,000 [10.55]	36,000 [10.55]
Net Sensible Capacity Btu [kW]	26,400 [7.74]	26,400 [7.74]	26,400 [7.74]	26,400 [7.74]
Net Latent Capacity Btu [kW]	9,600 [2.81]	9,600 [2.81]	9,600 [2.81]	9,600 [2.81]
Net System Power kW	3.08	3.08	3.08	3.08
<b>Heating Performance (Package Gas/Electric)<sup>3</sup></b>				
Heating Input Btu [kW]	80,000 [23.44]	120,000 [35.16]	80,000 [23.44]	120,000 [35.16]
Heating Output Btu [kW]	64,800 [18.99]	97,200 [28.48]	64,800 [18.99]	97,200 [28.48]
Temperature Rise Range °F [°C]	30-60 [16.7/33.3]	50-80 [27.8/44.4]	30-60 [16.7/33.3]	50-80 [27.8/44.4]
AFUE %	80	80	80	80
Steady State Efficiency (%)	81	81	81	81
No. Burners	4	6	4	6
No. Stages	1	1	1	1
Gas Connection Pipe Size in. [mm]	0.5 [12.7]	0.5 [12.7]	0.5 [12.7]	0.5 [12.7]
<b>Compressor</b>				
No./Type	1/Scroll	1/Scroll	1/Scroll	1/Scroll
<b>Outdoor Sound Rating (dB)</b>	78	78	78	78
<b>Outdoor Coil—Fin Type</b>	Louvered	Louvered	Louvered	Louvered
Tube Type	Rifled	Rifled	Rifled	Rifled
Tube Size in. [mm] OD	0.375 [9.5]	0.375 [9.5]	0.375 [9.5]	0.375 [9.5]
Face Area sq. ft. [sq. m]	16.91 [1.57]	16.91 [1.57]	16.91 [1.57]	16.91 [1.57]
Rows / FPI [FPcm]	1 / 22 [9]	1 / 22 [9]	1 / 22 [9]	1 / 22 [9]
<b>Indoor Coil—Fin Type</b>	Corrugated	Corrugated	Corrugated	Corrugated
Tube Type	Rifled	Rifled	Rifled	Rifled
Tube Size in. [mm]	0.375 [9.5]	0.375 [9.5]	0.375 [9.5]	0.375 [9.5]
Face Area sq. ft. [sq. m]	5.17 [0.48]	5.17 [0.48]	5.17 [0.48]	5.17 [0.48]
Rows / FPI [FPcm]	2 / 17 [7]	2 / 17 [7]	2 / 17 [7]	2 / 17 [7]
Refrigerant Control	TX Valves	TX Valves	TX Valves	TX Valves
Drain Connection No./Size in. [mm]	1/0.75 [19.05]	1/0.75 [19.05]	1/0.75 [19.05]	1/0.75 [19.05]
<b>Outdoor Fan—Type</b>	Propeller	Propeller	Propeller	Propeller
No. Used/Diameter in. [mm]	1/24 [609.6]	1/24 [609.6]	1/24 [609.6]	1/24 [609.6]
Drive Type/No. Speeds	Direct/1	Direct/1	Direct/1	Direct/1
CFM [L/s]	3680 [1737]	3680 [1737]	3680 [1737]	3680 [1737]
No. Motors/HP	1 at 1/3 HP	1 at 1/3 HP	1 at 1/3 HP	1 at 1/3 HP
Motor RPM	1075	1075	1075	1075
<b>Indoor Fan—Type</b>	FC Centrifugal	FC Centrifugal	FC Centrifugal	FC Centrifugal
No. Used/Diameter in. [mm]	1/10x10 [254x254]	1/10x10 [254x254]	1/10x10 [254x254]	1/10x10 [254x254]
Drive Type/No. Speeds	Belt/Variable	Belt/Variable	Belt/Variable	Belt/Variable
No. Motors	1	1	1	1
Motor HP	1/2	1/2	1/2	1/2
Motor RPM	1725	1725	1725	1725
Motor Frame Size	48	48	48	48
<b>Filter—Type</b>	Disposable	Disposable	Disposable	Disposable
Furnished	Yes	Yes	Yes	Yes
(No.) Size Recommended in. [mm]	(1)1x16x25 [25x406x635]	(1)1x16x25 [25x406x635]	(1)1x16x25 [25x406x635]	(1)1x16x25 [25x406x635]
	(1)1x16x25 [25x406x635]	(1)1x16x25 [25x406x635]	(1)1x16x25 [25x406x635]	(1)1x16x25 [25x406x635]
<b>Refrigerant Charge Oz. [g]</b>	93 [2637]	93 [2637]	93 [2637]	93 [2637]
<b>Weights</b>				
Net Weight lbs. [kg]	543 [246]	543 [246]	543 [246]	543 [246]
Ship Weight lbs. [kg]	550 [249]	550 [249]	550 [249]	550 [249]

See Page 26 for Notes.

[ ] Designates Metric Conversions



**NOM. SIZES 3-5 TONS [10.6-17.6 kW]**

Model RKNA- Series	A036JK08E	A036JK08X	A036JK12E	A036JK12X
<b>Cooling Performance<sup>1</sup></b>				<b>CONTINUED →</b>
Gross Cooling Capacity Btu [kW]	37,400 [10.96]	37,400 [10.96]	37,400 [10.96]	37,400 [10.96]
EER/SEER <sup>2</sup>	11.7/13	11.7/13	11.7/13	11.7/13
Nominal CFM/ARI Rated CFM [L/s]	1200/1200 [566/566]	1200/1200 [566/566]	1200/1200 [566/566]	1200/1200 [566/566]
ARI Net Cooling Capacity Btu [kW]	36,000 [10.55]	36,000 [10.55]	36,000 [10.55]	36,000 [10.55]
Net Sensible Capacity Btu [kW]	26,400 [7.74]	26,400 [7.74]	26,400 [7.74]	26,400 [7.74]
Net Latent Capacity Btu [kW]	9,600 [2.81]	9,600 [2.81]	9,600 [2.81]	9,600 [2.81]
Net System Power kW	3.08	3.08	3.08	3.08
<b>Heating Performance (Package Gas/Electric)<sup>3</sup></b>				
Heating Input Btu [kW]	80,000 [23.44]	80,000 [23.44]	120,000 [35.16]	120,000 [35.16]
Heating Output Btu [kW]	62,500 [18.31]	62,500 [18.31]	94,500 [27.69]	94,500 [27.69]
Temperature Rise Range °F [°C]	30-60 [16.7/33.3]	30-60 [16.7/33.3]	50-80 [27.8/44.4]	50-80 [27.8/44.4]
AFUE %	80	80	80	80
Steady State Efficiency (%)	81	81	81	81
No. Burners	4	4	6	6
No. Stages	1	1	1	1
Gas Connection Pipe Size in. [mm]	0.5 [12.7]	0.5 [12.7]	0.5 [12.7]	0.5 [12.7]
<b>Compressor</b>				
No./Type	1/Scroll	1/Scroll	1/Scroll	1/Scroll
<b>Outdoor Sound Rating (dB)</b>	78	78	78	78
<b>Outdoor Coil—Fin Type</b>	Louvered	Louvered	Louvered	Louvered
Tube Type	Rifled	Rifled	Rifled	Rifled
Tube Size in. [mm] OD	0.375 [9.5]	0.375 [9.5]	0.375 [9.5]	0.375 [9.5]
Face Area sq. ft. [sq. m]	16.91 [1.57]	16.91 [1.57]	16.91 [1.57]	16.91 [1.57]
Rows / FPI [FPcm]	1 / 22 [9]	1 / 22 [9]	1 / 22 [9]	1 / 22 [9]
<b>Indoor Coil—Fin Type</b>	Corrugated	Corrugated	Corrugated	Corrugated
Tube Type	Rifled	Rifled	Rifled	Rifled
Tube Size in. [mm]	0.375 [9.5]	0.375 [9.5]	0.375 [9.5]	0.375 [9.5]
Face Area sq. ft. [sq. m]	5.17 [0.48]	5.17 [0.48]	5.17 [0.48]	5.17 [0.48]
Rows / FPI [FPcm]	2 / 17 [7]	2 / 17 [7]	2 / 17 [7]	2 / 17 [7]
Refrigerant Control	TX Valves	TX Valves	TX Valves	TX Valves
Drain Connection No./Size in. [mm]	1/0.75 [19.05]	1/0.75 [19.05]	1/0.75 [19.05]	1/0.75 [19.05]
<b>Outdoor Fan—Type</b>	Propeller	Propeller	Propeller	Propeller
No. Used/Diameter in. [mm]	1/24 [609.6]	1/24 [609.6]	1/24 [609.6]	1/24 [609.6]
Drive Type/No. Speeds	Direct/1	Direct/1	Direct/1	Direct/1
CFM [L/s]	3680 [1737]	3680 [1737]	3680 [1737]	3680 [1737]
No. Motors/HP	1 at 1/3 HP	1 at 1/3 HP	1 at 1/3 HP	1 at 1/3 HP
Motor RPM	1075	1075	1075	1075
<b>Indoor Fan—Type</b>	FC Centrifugal	FC Centrifugal	FC Centrifugal	FC Centrifugal
No. Used/Diameter in. [mm]	1/10x10 [254x254]	1/10x10 [254x254]	1/10x10 [254x254]	1/10x10 [254x254]
Drive Type/No. Speeds	Direct/3	Direct/3	Direct/3	Direct/3
No. Motors	1	1	1	1
Motor HP	1/2	1/2	1/2	1/2
Motor RPM	1075	1075	1075	1075
Motor Frame Size	48	48	48	48
<b>Filter—Type</b>	Disposable	Disposable	Disposable	Disposable
Furnished	Yes	Yes	Yes	Yes
(No.) Size Recommended in. [mm]	(1)1x16x25 [25x406x635]	(1)1x16x25 [25x406x635]	(1)1x16x25 [25x406x635]	(1)1x16x25 [25x406x635]
	(1)1x16x25 [25x406x635]	(1)1x16x25 [25x406x635]	(1)1x16x25 [25x406x635]	(1)1x16x25 [25x406x635]
<b>Refrigerant Charge Oz. [g]</b>	93 [2637]	93 [2637]	93 [2637]	93 [2637]
<b>Weights</b>				
Net Weight lbs. [kg]	543 [246]	543 [246]	543 [246]	543 [246]
Ship Weight lbs. [kg]	550 [249]	550 [249]	550 [249]	550 [249]

See Page 26 for Notes.

[ ] Designates Metric Conversions



## NOM. SIZES 3-5 TONS [10.6-17.6 kW]

Model RKNA- Series	A042CK08E	A042CK12E	A042CL08E	A042CL12E
<b>Cooling Performance<sup>1</sup></b>				
	<b>CONTINUED →</b>			
Gross Cooling Capacity Btu [kW]	43,000 [12.6]	43,000 [12.6]	43,000 [12.6]	43,000 [12.6]
EER/SEER <sup>2</sup>	11.45/13	11.45/13	11.45/13	11.45/13
Nominal CFM/ARI Rated CFM [L/s]	1400/1450 [661/684]	1400/1450 [661/684]	1400/1450 [661/684]	1400/1450 [661/684]
ARI Net Cooling Capacity Btu [kW]	41,000 [12.01]	41,000 [12.01]	41,000 [12.01]	41,000 [12.01]
Net Sensible Capacity Btu [kW]	30,000 [8.79]	30,000 [8.79]	30,000 [8.79]	30,000 [8.79]
Net Latent Capacity Btu [kW]	11,000 [3.22]	11,000 [3.22]	11,000 [3.22]	11,000 [3.22]
Net System Power kW	3.59	3.59	3.59	3.59
<b>Heating Performance (Package Gas/Electric)<sup>3</sup></b>				
Heating Input Btu [kW]	80,000 [23.44]	120,000 [35.16]	80,000 [23.44]	120,000 [35.16]
Heating Output Btu [kW]	64,800 [18.99]	97,200 [28.48]	64,800 [18.99]	97,200 [28.48]
Temperature Rise Range °F [°C]	30-60 [16.7/33.3]	50-80 [27.8/44.4]	30-60 [16.7/33.3]	50-80 [27.8/44.4]
AFUE %	80	80	80	80
Steady State Efficiency (%)	81	81	81	81
No. Burners	4	6	4	6
No. Stages	1	1	1	1
Gas Connection Pipe Size in. [mm]	0.5 [12.7]	0.5 [12.7]	0.5 [12.7]	0.5 [12.7]
<b>Compressor</b>				
No./Type	1/Scroll	1/Scroll	1/Scroll	1/Scroll
<b>Outdoor Sound Rating (dB)</b>				
	78	78	78	78
<b>Outdoor Coil—Fin Type</b>				
Tube Type	Louvered	Louvered	Louvered	Louvered
Tube Type	Rifled	Rifled	Rifled	Rifled
Tube Size in. [mm] OD	0.375 [9.5]	0.375 [9.5]	0.375 [9.5]	0.375 [9.5]
Face Area sq. ft. [sq. m]	16.91 [1.57]	16.91 [1.57]	16.91 [1.57]	16.91 [1.57]
Rows / FPI [FPcm]	1.53 / 22 [9]	1.53 / 22 [9]	1.53 / 22 [9]	1.53 / 22 [9]
<b>Indoor Coil—Fin Type</b>				
Tube Type	Corrugated	Corrugated	Corrugated	Corrugated
Tube Type	Rifled	Rifled	Rifled	Rifled
Tube Size in. [mm]	0.375 [9.5]	0.375 [9.5]	0.375 [9.5]	0.375 [9.5]
Face Area sq. ft. [sq. m]	5.17 [0.48]	5.17 [0.48]	5.17 [0.48]	5.17 [0.48]
Rows / FPI [FPcm]	3 / 13 [5]	3 / 13 [5]	3 / 13 [5]	3 / 13 [5]
Refrigerant Control	TX Valves	TX Valves	TX Valves	TX Valves
Drain Connection No./Size in. [mm]	1/0.75 [19.05]	1/0.75 [19.05]	1/0.75 [19.05]	1/0.75 [19.05]
<b>Outdoor Fan—Type</b>				
Propeller	Propeller	Propeller	Propeller	Propeller
No. Used/Diameter in. [mm]	1/24 [609.6]	1/24 [609.6]	1/24 [609.6]	1/24 [609.6]
Drive Type/No. Speeds	Direct/1	Direct/1	Direct/1	Direct/1
CFM [L/s]	3680 [1737]	3680 [1737]	3680 [1737]	3680 [1737]
No. Motors/HP	1 at 1/3 HP	1 at 1/3 HP	1 at 1/3 HP	1 at 1/3 HP
Motor RPM	1075	1075	1075	1075
<b>Indoor Fan—Type</b>				
FC Centrifugal	FC Centrifugal	FC Centrifugal	FC Centrifugal	FC Centrifugal
No. Used/Diameter in. [mm]	1/10x10 [254x254]	1/10x10 [254x254]	1/10x10 [254x254]	1/10x10 [254x254]
Drive Type/No. Speeds	Direct/3	Direct/3	Belt/Variable	Belt/Variable
No. Motors	1	1	1	1
Motor HP	1/2	1/2	1/2	1/2
Motor RPM	1075	1075	1725	1725
Motor Frame Size	48	48	48	48
<b>Filter—Type</b>				
Disposable	Disposable	Disposable	Disposable	Disposable
Furnished	Yes	Yes	Yes	Yes
(No.) Size Recommended in. [mm]	(1)1x16x25 [25x406x635]	(1)1x16x25 [25x406x635]	(1)1x16x25 [25x406x635]	(1)1x16x25 [25x406x635]
	(1)1x16x25 [25x406x635]	(1)1x16x25 [25x406x635]	(1)1x16x25 [25x406x635]	(1)1x16x25 [25x406x635]
<b>Refrigerant Charge Oz. [g]</b>				
	117 [3317]	117 [3317]	117 [3317]	117 [3317]
<b>Weights</b>				
Net Weight lbs. [kg]	570 [259]	579 [263]	570 [259]	579 [263]
Ship Weight lbs. [kg]	577 [262]	586 [266]	577 [262]	586 [266]

See Page 26 for Notes.

[ ] Designates Metric Conversions



**NOM. SIZES 3-5 TONS [10.6-17.6 kW]**

Model RKNA- Series	A042CM08E	A042CM12E	A042DK08E	A042DK12E
<b>Cooling Performance<sup>1</sup></b>				<b>CONTINUED</b> →
Gross Cooling Capacity Btu [kW]	43,000 [12.6]	43,000 [12.6]	43,000 [12.6]	43,000 [12.6]
EER/SEER <sup>2</sup>	11.45/13	11.45/13	11.45/13	11.45/13
Nominal CFM/ARI Rated CFM [L/s]	1400/1450 [661/684]	1400/1450 [661/684]	1400/1450 [661/684]	1400/1450 [661/684]
ARI Net Cooling Capacity Btu [kW]	41,000 [12.01]	41,000 [12.01]	41,000 [12.01]	41,000 [12.01]
Net Sensible Capacity Btu [kW]	30,000 [8.79]	30,000 [8.79]	30,000 [8.79]	30,000 [8.79]
Net Latent Capacity Btu [kW]	11,000 [3.22]	11,000 [3.22]	11,000 [3.22]	11,000 [3.22]
Net System Power kW	3.59	3.59	3.59	3.59
<b>Heating Performance (Package Gas/Electric)<sup>3</sup></b>				
Heating Input Btu [kW]	80,000 [23.44]	120,000 [35.16]	80,000 [23.44]	120,000 [35.16]
Heating Output Btu [kW]	64,800 [18.99]	97,200 [28.48]	64,800 [18.99]	97,200 [28.48]
Temperature Rise Range °F [°C]	30-60 [16.7/33.3]	50-80 [27.8/44.4]	30-60 [16.7/33.3]	50-80 [27.8/44.4]
AFUE %	80	80	80	80
Steady State Efficiency (%)	81	81	81	81
No. Burners	4	6	4	6
No. Stages	1	1	1	1
Gas Connection Pipe Size in. [mm]	0.5 [12.7]	0.5 [12.7]	0.5 [12.7]	0.5 [12.7]
<b>Compressor</b>				
No./Type	1/Scroll	1/Scroll	1/Scroll	1/Scroll
<b>Outdoor Sound Rating (dB)</b>	78	78	78	78
<b>Outdoor Coil—Fin Type</b>	Louvered	Louvered	Louvered	Louvered
Tube Type	Rifled	Rifled	Rifled	Rifled
Tube Size in. [mm] OD	0.375 [9.5]	0.375 [9.5]	0.375 [9.5]	0.375 [9.5]
Face Area sq. ft. [sq. m]	16.91 [1.57]	16.91 [1.57]	16.91 [1.57]	16.91 [1.57]
Rows / FPI [FPcm]	1.53 / 22 [9]	1.53 / 22 [9]	1.53 / 22 [9]	1.53 / 22 [9]
<b>Indoor Coil—Fin Type</b>	Corrugated	Corrugated	Corrugated	Corrugated
Tube Type	Rifled	Rifled	Rifled	Rifled
Tube Size in. [mm]	0.375 [9.5]	0.375 [9.5]	0.375 [9.5]	0.375 [9.5]
Face Area sq. ft. [sq. m]	5.17 [0.48]	5.17 [0.48]	5.17 [0.48]	5.17 [0.48]
Rows / FPI [FPcm]	3 / 13 [5]	3 / 13 [5]	3 / 13 [5]	3 / 13 [5]
Refrigerant Control	TX Valves	TX Valves	TX Valves	TX Valves
Drain Connection No./Size in. [mm]	1/0.75 [19.05]	1/0.75 [19.05]	1/0.75 [19.05]	1/0.75 [19.05]
<b>Outdoor Fan—Type</b>	Propeller	Propeller	Propeller	Propeller
No. Used/Diameter in. [mm]	1/24 [609.6]	1/24 [609.6]	1/24 [609.6]	1/24 [609.6]
Drive Type/No. Speeds	Direct/1	Direct/1	Direct/1	Direct/1
CFM [L/s]	3680 [1737]	3680 [1737]	3680 [1737]	3680 [1737]
No. Motors/HP	1 at 1/3 HP	1 at 1/3 HP	1 at 1/3 HP	1 at 1/3 HP
Motor RPM	1075	1075	1075	1075
<b>Indoor Fan—Type</b>	FC Centrifugal	FC Centrifugal	FC Centrifugal	FC Centrifugal
No. Used/Diameter in. [mm]	1/10x10 [254x254]	1/10x10 [254x254]	1/10x10 [254x254]	1/10x10 [254x254]
Drive Type/No. Speeds	Belt/Variable	Belt/Variable	Direct/3	Direct/3
No. Motors	1	1	1	1
Motor HP	1/2	1/2	1/2	1/2
Motor RPM	1725	1725	1075	1075
Motor Frame Size	48	48	48	48
<b>Filter—Type</b>	Disposable	Disposable	Disposable	Disposable
Furnished	Yes	Yes	Yes	Yes
(No.) Size Recommended in. [mm]	(1)1x16x25 [25x406x635]	(1)1x16x25 [25x406x635]	(1)1x16x25 [25x406x635]	(1)1x16x25 [25x406x635]
	(1)1x16x25 [25x406x635]	(1)1x16x25 [25x406x635]	(1)1x16x25 [25x406x635]	(1)1x16x25 [25x406x635]
<b>Refrigerant Charge Oz. [g]</b>	117 [3317]	117 [3317]	117 [3317]	117 [3317]
<b>Weights</b>				
Net Weight lbs. [kg]	570 [259]	570 [259]	570 [259]	579 [263]
Ship Weight lbs. [kg]	577 [262]	577 [262]	577 [262]	586 [266]

See Page 26 for Notes.

[ ] Designates Metric Conversions



## NOM. SIZES 3-5 TONS [10.6-17.6 kW]

Model RKNA- Series	A042DL08E	A042DL12E	A042DM08E	A042DM12E
<b>Cooling Performance<sup>1</sup></b>				<b>CONTINUED</b> →
Gross Cooling Capacity Btu [kW]	43,000 [12.6]	43,000 [12.6]	43,000 [12.6]	43,000 [12.6]
EER/SEER <sup>2</sup>	11.45/13	11.45/13	11.45/13	11.45/13
Nominal CFM/ARI Rated CFM [L/s]	1400/1450 [661/684]	1400/1450 [661/684]	1400/1450 [661/684]	1400/1450 [661/684]
ARI Net Cooling Capacity Btu [kW]	41,000 [12.01]	41,000 [12.01]	41,000 [12.01]	41,000 [12.01]
Net Sensible Capacity Btu [kW]	30,000 [8.79]	30,000 [8.79]	30,000 [8.79]	30,000 [8.79]
Net Latent Capacity Btu [kW]	11,000 [3.22]	11,000 [3.22]	11,000 [3.22]	11,000 [3.22]
Net System Power kW	3.59	3.59	3.59	3.59
<b>Heating Performance (Package Gas/Electric)<sup>3</sup></b>				
Heating Input Btu [kW]	80,000 [23.44]	120,000 [35.16]	80,000 [23.44]	120,000 [35.16]
Heating Output Btu [kW]	64,800 [18.99]	97,200 [28.48]	64,800 [18.99]	97,200 [28.48]
Temperature Rise Range °F [°C]	30-60 [16.7/33.3]	50-80 [27.8/44.4]	30-60 [16.7/33.3]	50-80 [27.8/44.4]
AFUE %	80	80	80	80
Steady State Efficiency (%)	81	81	81	81
No. Burners	4	6	4	6
No. Stages	1	1	1	1
Gas Connection Pipe Size in. [mm]	0.5 [12.7]	0.5 [12.7]	0.5 [12.7]	0.5 [12.7]
<b>Compressor</b>				
No./Type	1/Scroll	1/Scroll	1/Scroll	1/Scroll
<b>Outdoor Sound Rating (dB)</b>	78	78	78	78
<b>Outdoor Coil—Fin Type</b>	Louvered	Louvered	Louvered	Louvered
Tube Type	Rifled	Rifled	Rifled	Rifled
Tube Size in. [mm] OD	0.375 [9.5]	0.375 [9.5]	0.375 [9.5]	0.375 [9.5]
Face Area sq. ft. [sq. m]	16.91 [1.57]	16.91 [1.57]	16.91 [1.57]	16.91 [1.57]
Rows / FPI [FPcm]	1.53 / 22 [9]	1.53 / 22 [9]	1.53 / 22 [9]	1.53 / 22 [9]
<b>Indoor Coil—Fin Type</b>	Corrugated	Corrugated	Corrugated	Corrugated
Tube Type	Rifled	Rifled	Rifled	Rifled
Tube Size in. [mm]	0.375 [9.5]	0.375 [9.5]	0.375 [9.5]	0.375 [9.5]
Face Area sq. ft. [sq. m]	5.17 [0.48]	5.17 [0.48]	5.17 [0.48]	5.17 [0.48]
Rows / FPI [FPcm]	3 / 13 [5]	3 / 13 [5]	3 / 13 [5]	3 / 13 [5]
Refrigerant Control	TX Valves	TX Valves	TX Valves	TX Valves
Drain Connection No./Size in. [mm]	1/0.75 [19.05]	1/0.75 [19.05]	1/0.75 [19.05]	1/0.75 [19.05]
<b>Outdoor Fan—Type</b>	Propeller	Propeller	Propeller	Propeller
No. Used/Diameter in. [mm]	1/24 [609.6]	1/24 [609.6]	1/24 [609.6]	1/24 [609.6]
Drive Type/No. Speeds	Direct/1	Direct/1	Direct/1	Direct/1
CFM [L/s]	3680 [1737]	3680 [1737]	3680 [1737]	3680 [1737]
No. Motors/HP	1 at 1/3 HP	1 at 1/3 HP	1 at 1/3 HP	1 at 1/3 HP
Motor RPM	1075	1075	1075	1075
<b>Indoor Fan—Type</b>	FC Centrifugal	FC Centrifugal	FC Centrifugal	FC Centrifugal
No. Used/Diameter in. [mm]	1/10x10 [254x254]	1/10x10 [254x254]	1/10x10 [254x254]	1/10x10 [254x254]
Drive Type/No. Speeds	Belt/Variable	Belt/Variable	Belt/Variable	Belt/Variable
No. Motors	1	1	1	1
Motor HP	1/2	1/2	1/2	1/2
Motor RPM	1725	1725	1725	1725
Motor Frame Size	48	48	48	48
<b>Filter—Type</b>	Disposable	Disposable	Disposable	Disposable
Furnished	Yes	Yes	Yes	Yes
(No.) Size Recommended in. [mm]	(1)1x16x25 [25x406x635]	(1)1x16x25 [25x406x635]	(1)1x16x25 [25x406x635]	(1)1x16x25 [25x406x635]
	(1)1x16x25 [25x406x635]	(1)1x16x25 [25x406x635]	(1)1x16x25 [25x406x635]	(1)1x16x25 [25x406x635]
<b>Refrigerant Charge Oz. [g]</b>	117 [3317]	117 [3317]	117 [3317]	117 [3317]
<b>Weights</b>				
Net Weight lbs. [kg]	570 [259]	579 [263]	570 [259]	570 [259]
Ship Weight lbs. [kg]	577 [262]	586 [266]	577 [262]	577 [262]

See Page 26 for Notes.

[ ] Designates Metric Conversions



**NOM. SIZES 3-5 TONS [10.6-17.6 kW]**

Model RKNA- Series	A042JK08E	A042JK08X	A042JK12E	A042JK12X
<b>Cooling Performance<sup>1</sup></b>				<b>CONTINUED</b> →
Gross Cooling Capacity Btu [kW]	43,000 [12.6]	43,000 [12.6]	43,000 [12.6]	43,000 [12.6]
EER/SEER <sup>2</sup>	11.45/13	11.45/13	11.45/13	11.45/13
Nominal CFM/ARI Rated CFM [L/s]	1400/1450 [661/684]	1400/1450 [661/684]	1400/1450 [661/684]	1400/1450 [661/684]
ARI Net Cooling Capacity Btu [kW]	41,000 [12.01]	41,000 [12.01]	41,000 [12.01]	41,000 [12.01]
Net Sensible Capacity Btu [kW]	30,000 [8.79]	30,000 [8.79]	30,000 [8.79]	30,000 [8.79]
Net Latent Capacity Btu [kW]	11,000 [3.22]	11,000 [3.22]	11,000 [3.22]	11,000 [3.22]
Net System Power kW	3.59	3.59	3.59	3.59
<b>Heating Performance (Package Gas/Electric)<sup>3</sup></b>				
Heating Input Btu [kW]	80,000 [23.44]	80,000 [23.44]	120,000 [35.16]	120,000 [35.16]
Heating Output Btu [kW]	62,500 [18.31]	62,500 [18.31]	94,500 [27.69]	94,500 [27.69]
Temperature Rise Range °F [°C]	30-60 [16.7/33.3]	30-60 [16.7/33.3]	50-80 [27.8/44.4]	50-80 [27.8/44.4]
AFUE %	80	80	80	80
Steady State Efficiency (%)	81	81	81	81
No. Burners	4	4	6	6
No. Stages	1	1	1	1
Gas Connection Pipe Size in. [mm]	0.5 [12.7]	0.5 [12.7]	0.5 [12.7]	0.5 [12.7]
<b>Compressor</b>				
No./Type	1/Scroll	1/Scroll	1/Scroll	1/Scroll
<b>Outdoor Sound Rating (dB)</b>	78	78	78	78
<b>Outdoor Coil—Fin Type</b>	Louvered	Louvered	Louvered	Louvered
Tube Type	Rifled	Rifled	Rifled	Rifled
Tube Size in. [mm] OD	0.375 [9.5]	0.375 [9.5]	0.375 [9.5]	0.375 [9.5]
Face Area sq. ft. [sq. m]	16.91 [1.57]	16.91 [1.57]	16.91 [1.57]	16.91 [1.57]
Rows / FPI [FPcm]	1.53 / 22 [9]	1.53 / 22 [9]	1.53 / 22 [9]	1.53 / 22 [9]
<b>Indoor Coil—Fin Type</b>	Corrugated	Corrugated	Corrugated	Corrugated
Tube Type	Rifled	Rifled	Rifled	Rifled
Tube Size in. [mm]	0.375 [9.5]	0.375 [9.5]	0.375 [9.5]	0.375 [9.5]
Face Area sq. ft. [sq. m]	5.17 [0.48]	5.17 [0.48]	5.17 [0.48]	5.17 [0.48]
Rows / FPI [FPcm]	3 / 13 [5]	3 / 13 [5]	3 / 13 [5]	3 / 13 [5]
Refrigerant Control	TX Valves	TX Valves	TX Valves	TX Valves
Drain Connection No./Size in. [mm]	1/0.75 [19.05]	1/0.75 [19.05]	1/0.75 [19.05]	1/0.75 [19.05]
<b>Outdoor Fan—Type</b>	Propeller	Propeller	Propeller	Propeller
No. Used/Diameter in. [mm]	1/24 [609.6]	1/24 [609.6]	1/24 [609.6]	1/24 [609.6]
Drive Type/No. Speeds	Direct/1	Direct/1	Direct/1	Direct/1
CFM [L/s]	3680 [1737]	3680 [1737]	3680 [1737]	3680 [1737]
No. Motors/HP	1 at 1/3 HP	1 at 1/3 HP	1 at 1/3 HP	1 at 1/3 HP
Motor RPM	1075	1075	1075	1075
<b>Indoor Fan—Type</b>	FC Centrifugal	FC Centrifugal	FC Centrifugal	FC Centrifugal
No. Used/Diameter in. [mm]	1/10x10 [254x254]	1/10x10 [254x254]	1/10x10 [254x254]	1/10x10 [254x254]
Drive Type/No. Speeds	Direct/3	Direct/3	Direct/3	Direct/3
No. Motors	1	1	1	1
Motor HP	1/2	1/2	1/2	1/2
Motor RPM	1075	1075	1725	1075
Motor Frame Size	48	48	48	48
<b>Filter—Type</b>	Disposable	Disposable	Disposable	Disposable
Furnished	Yes	Yes	Yes	Yes
(No.) Size Recommended in. [mm]	(1)1x16x25 [25x406x635]	(1)1x16x25 [25x406x635]	(1)1x16x25 [25x406x635]	(1)1x16x25 [25x406x635]
	(1)1x16x25 [25x406x635]	(1)1x16x25 [25x406x635]	(1)1x16x25 [25x406x635]	(1)1x16x25 [25x406x635]
<b>Refrigerant Charge Oz. [g]</b>	117 [3317]	117 [3317]	117 [3317]	117 [3317]
<b>Weights</b>				
Net Weight lbs. [kg]	570 [259]	570 [259]	579 [263]	579 [263]
Ship Weight lbs. [kg]	577 [262]	577 [262]	586 [266]	586 [266]

See Page 26 for Notes.

[ ] Designates Metric Conversions



## NOM. SIZES 3-5 TONS [10.6-17.6 kW]

Model RKNA- Series	A048CK08E	A048CK10E	A048CK13E	A048CL08E
<b>Cooling Performance<sup>1</sup></b>				<b>CONTINUED</b> →
Gross Cooling Capacity Btu [kW]	49,000 [14.36]	49,000 [14.36]	49,000 [14.36]	49,000 [14.36]
EER/SEER <sup>2</sup>	11.4/13.1	11.4/13.1	11.4/13.1	11.4/13.1
Nominal CFM/ARI Rated CFM [L/s]	1600/1550 [755/731]	1600/1550 [755/731]	1600/1550 [755/731]	1600/1550 [755/731]
ARI Net Cooling Capacity Btu [kW]	47,000 [13.77]	47,000 [13.77]	47,000 [13.77]	47,000 [13.77]
Net Sensible Capacity Btu [kW]	33,600 [9.84]	33,600 [9.84]	33,600 [9.84]	33,600 [9.84]
Net Latent Capacity Btu [kW]	13,400 [3.93]	13,400 [3.93]	13,400 [3.93]	13,400 [3.93]
Net System Power kW	4.15	4.15	4.15	4.15
<b>Heating Performance (Package Gas/Electric)<sup>3</sup></b>				
Heating Input Btu [kW]	80,000 [23.44]	100,000 [29.3]	135,000 [39.56]	80,000 [23.44]
Heating Output Btu [kW]	64,800 [18.99]	81,000 [23.73]	109,400 [32.05]	64,800 [18.99]
Temperature Rise Range °F [°C]	30-60 [16.7/33.3]	40-70 [22.2/38.9]	50-80 [27.8/44.4]	30-60 [16.7/33.3]
AFUE %	80	80	80	80
Steady State Efficiency (%)	81	81	81	81
No. Burners	4	5	6	4
No. Stages	1	1	1	1
Gas Connection Pipe Size in. [mm]	0.5 [12.7]	0.5 [12.7]	0.5 [12.7]	0.5 [12.7]
<b>Compressor</b>				
No./Type	1/Scroll	1/Scroll	1/Scroll	1/Scroll
<b>Outdoor Sound Rating (dB)</b>	78	78	78	78
<b>Outdoor Coil—Fin Type</b>	Louvered	Louvered	Louvered	Louvered
Tube Type	Rifled	Rifled	Rifled	Rifled
Tube Size in. [mm] OD	0.375 [9.5]	0.375 [9.5]	0.375 [9.5]	0.375 [9.5]
Face Area sq. ft. [sq. m]	16.56 [1.54]	16.56 [1.54]	16.56 [1.54]	16.56 [1.54]
Rows / FPI [FPcm]	2 / 22 [9]	2 / 22 [9]	2 / 22 [9]	2 / 22 [9]
<b>Indoor Coil—Fin Type</b>	Corrugated	Corrugated	Corrugated	Corrugated
Tube Type	Rifled	Rifled	Rifled	Rifled
Tube Size in. [mm]	0.375 [9.5]	0.375 [9.5]	0.375 [9.5]	0.375 [9.5]
Face Area sq. ft. [sq. m]	5.17 [0.48]	5.17 [0.48]	5.17 [0.48]	5.17 [0.48]
Rows / FPI [FPcm]	3 / 15 [6]	3 / 15 [6]	3 / 15 [6]	3 / 15 [6]
Refrigerant Control	TX Valves	TX Valves	TX Valves	TX Valves
Drain Connection No./Size in. [mm]	1/0.75 [19.05]	1/0.75 [19.05]	1/0.75 [19.05]	1/0.75 [19.05]
<b>Outdoor Fan—Type</b>	Propeller	Propeller	Propeller	Propeller
No. Used/Diameter in. [mm]	1/24 [609.6]	1/24 [609.6]	1/24 [609.6]	1/24 [609.6]
Drive Type/No. Speeds	Direct/1	Direct/1	Direct/1	Direct/1
CFM [L/s]	3680 [1737]	3680 [1737]	3680 [1737]	3680 [1737]
No. Motors/HP	1 at 1/3 HP	1 at 1/3 HP	1 at 1/3 HP	1 at 1/3 HP
Motor RPM	1075	1075	1075	1075
<b>Indoor Fan—Type</b>	FC Centrifugal	FC Centrifugal	FC Centrifugal	FC Centrifugal
No. Used/Diameter in. [mm]	1/10x10 [254x254]	1/10x10 [254x254]	1/10x10 [254x254]	1/10x10 [254x254]
Drive Type/No. Speeds	Direct/3	Direct/3	Direct/3	Belt/Variable
No. Motors	1	1	1	1
Motor HP	1/2	1/2	1/2	1/2
Motor RPM	1075	1075	1075	1725
Motor Frame Size	48	48	48	48
<b>Filter—Type</b>	Disposable	Disposable	Disposable	Disposable
Furnished	Yes	Yes	Yes	Yes
(No.) Size Recommended in. [mm]	(1)1x16x25 [25x406x635]	(1)1x16x25 [25x406x635]	(1)1x16x25 [25x406x635]	(1)1x16x25 [25x406x635]
	(1)1x16x25 [25x406x635]	(1)1x16x25 [25x406x635]	(1)1x16x25 [25x406x635]	(1)1x16x25 [25x406x635]
<b>Refrigerant Charge Oz. [g]</b>	167 [4734]	167 [4734]	167 [4734]	167 [4734]
<b>Weights</b>				
Net Weight lbs. [kg]	580 [263]	580 [263]	585 [265]	580 [263]
Ship Weight lbs. [kg]	587 [266]	587 [266]	592 [269]	587 [266]

See Page 26 for Notes.

[ ] Designates Metric Conversions



**NOM. SIZES 3-5 TONS [10.6-17.6 kW]**

Model RKNA- Series	A048CL10E	A048CL13E	A048CM08E	A048CM10E
<b>Cooling Performance<sup>1</sup></b>				<b>CONTINUED</b> →
Gross Cooling Capacity Btu [kW]	49,000 [14.36]	49,000 [14.36]	49,000 [14.36]	49,000 [14.36]
EER/SEER <sup>2</sup>	11.4/13.1	11.4/13.1	11.4/13.1	11.4/13.1
Nominal CFM/ARI Rated CFM [L/s]	1600/1550 [755/731]	1600/1550 [755/731]	1600/1550 [755/731]	1600/1550 [755/731]
ARI Net Cooling Capacity Btu [kW]	47,000 [13.77]	47,000 [13.77]	47,000 [13.77]	47,000 [13.77]
Net Sensible Capacity Btu [kW]	33,600 [9.84]	33,600 [9.84]	33,600 [9.84]	33,600 [9.84]
Net Latent Capacity Btu [kW]	13,400 [3.93]	13,400 [3.93]	13,400 [3.93]	13,400 [3.93]
Net System Power kW	4.15	4.15	4.15	4.15
<b>Heating Performance (Package Gas/Electric)<sup>3</sup></b>				
Heating Input Btu [kW]	100,000 [29.3]	135,000 [39.56]	80,000 [23.44]	100,000 [29.3]
Heating Output Btu [kW]	81,000 [23.73]	109,400 [32.05]	64,800 [18.99]	81,000 [23.73]
Temperature Rise Range °F [°C]	30-60 [16.7/33.3]	50-80 [27.8/44.4]	30-60 [16.7/33.3]	30-60 [16.7/33.3]
AFUE %	80	80	80	80
Steady State Efficiency (%)	81	81	81	81
No. Burners	5	6	4	5
No. Stages	1	1	1	1
Gas Connection Pipe Size in. [mm]	0.5 [12.7]	0.5 [12.7]	0.5 [12.7]	0.5 [12.7]
<b>Compressor</b>				
No./Type	1/Scroll	1/Scroll	1/Scroll	1/Scroll
<b>Outdoor Sound Rating (dB)</b>	78	78	78	78
<b>Outdoor Coil—Fin Type</b>	Louvered	Louvered	Louvered	Louvered
Tube Type	Rifled	Rifled	Rifled	Rifled
Tube Size in. [mm] OD	0.375 [9.5]	0.375 [9.5]	0.375 [9.5]	0.375 [9.5]
Face Area sq. ft. [sq. m]	16.56 [1.54]	16.56 [1.54]	16.56 [1.54]	16.56 [1.54]
Rows / FPI [FPcm]	2 / 22 [9]	2 / 22 [9]	2 / 22 [9]	2 / 22 [9]
<b>Indoor Coil—Fin Type</b>	Corrugated	Corrugated	Corrugated	Corrugated
Tube Type	Rifled	Rifled	Rifled	Rifled
Tube Size in. [mm]	0.375 [9.5]	0.375 [9.5]	0.375 [9.5]	0.375 [9.5]
Face Area sq. ft. [sq. m]	5.17 [0.48]	5.17 [0.48]	5.17 [0.48]	5.17 [0.48]
Rows / FPI [FPcm]	3 / 15 [6]	3 / 15 [6]	3 / 15 [6]	3 / 15 [6]
Refrigerant Control	TX Valves	TX Valves	TX Valves	TX Valves
Drain Connection No./Size in. [mm]	1/0.75 [19.05]	1/0.75 [19.05]	1/0.75 [19.05]	1/0.75 [19.05]
<b>Outdoor Fan—Type</b>	Propeller	Propeller	Propeller	Propeller
No. Used/Diameter in. [mm]	1/24 [609.6]	1/24 [609.6]	1/24 [609.6]	1/24 [609.6]
Drive Type/No. Speeds	Direct/1	Direct/1	Direct/1	Direct/1
CFM [L/s]	3680 [1737]	3680 [1737]	3680 [1737]	3680 [1737]
No. Motors/HP	1 at 1/3 HP	1 at 1/3 HP	1 at 1/3 HP	1 at 1/3 HP
Motor RPM	1075	1075	1075	1075
<b>Indoor Fan—Type</b>	FC Centrifugal	FC Centrifugal	FC Centrifugal	FC Centrifugal
No. Used/Diameter in. [mm]	1/10x10 [254x254]	1/10x10 [254x254]	1/10x10 [254x254]	1/10x10 [254x254]
Drive Type/No. Speeds	Belt/Variable	Belt/Variable	Belt/Variable	Belt/Variable
No. Motors	1	1	1	1
Motor HP	1/2	1/2	3/4	3/4
Motor RPM	1725	1725	1725	1725
Motor Frame Size	48	48	56	56
<b>Filter—Type</b>	Disposable	Disposable	Disposable	Disposable
Furnished	Yes	Yes	Yes	Yes
(No.) Size Recommended in. [mm]	(1)1x16x25 [25x406x635]	(1)1x16x25 [25x406x635]	(1)1x16x25 [25x406x635]	(1)1x16x25 [25x406x635]
	(1)1x16x25 [25x406x635]	(1)1x16x25 [25x406x635]	(1)1x16x25 [25x406x635]	(1)1x16x25 [25x406x635]
<b>Refrigerant Charge Oz. [g]</b>	167 [4734]	167 [4734]	167 [4734]	167 [4734]
<b>Weights</b>				
Net Weight lbs. [kg]	580 [263]	585 [265]	580 [263]	580 [263]
Ship Weight lbs. [kg]	587 [266]	592 [269]	587 [266]	587 [266]

See Page 26 for Notes.

[ ] Designates Metric Conversions



## NOM. SIZES 3-5 TONS [10.6-17.6 kW]

Model RKNA- Series	A048CM13E	A048DK08E	A048DK10E	A048DK13E
<b>Cooling Performance<sup>1</sup></b>				<b>CONTINUED</b> →
Gross Cooling Capacity Btu [kW]	49,000 [14.36]	49,000 [14.36]	49,000 [14.36]	49,000 [14.36]
EER/SEER <sup>2</sup>	11.4/13.1	11.4/13.1	11.4/13.1	11.4/13.1
Nominal CFM/ARI Rated CFM [L/s]	1600/1550 [755/731]	1600/1550 [755/731]	1600/1550 [755/731]	1600/1550 [755/731]
ARI Net Cooling Capacity Btu [kW]	47,000 [13.77]	47,000 [13.77]	47,000 [13.77]	47,000 [13.77]
Net Sensible Capacity Btu [kW]	33,600 [9.84]	33,600 [9.84]	33,600 [9.84]	33,600 [9.84]
Net Latent Capacity Btu [kW]	13,400 [3.93]	13,400 [3.93]	13,400 [3.93]	13,400 [3.93]
Net System Power kW	4.15	4.15	4.15	4.15
<b>Heating Performance (Package Gas/Electric)<sup>3</sup></b>				
Heating Input Btu [kW]	135,000 [39.56]	80,000 [23.44]	100,000 [29.3]	135,000 [39.56]
Heating Output Btu [kW]	109,400 [32.05]	64,800 [18.99]	81,000 [23.73]	109,400 [32.05]
Temperature Rise Range °F [°C]	50-80 [27.8/44.4]	30-60 [16.7/33.3]	30-60 [16.7/33.3]	50-80 [27.8/44.4]
AFUE %	80	80	80	80
Steady State Efficiency (%)	81	81	81	81
No. Burners	6	4	5	6
No. Stages	1	1	1	1
Gas Connection Pipe Size in. [mm]	0.5 [12.7]	0.5 [12.7]	0.5 [12.7]	0.5 [12.7]
<b>Compressor</b>				
No./Type	1/Scroll	1/Scroll	1/Scroll	1/Scroll
<b>Outdoor Sound Rating (dB)</b>	78	78	78	78
<b>Outdoor Coil—Fin Type</b>	Louvered	Louvered	Louvered	Louvered
Tube Type	Rifled	Rifled	Rifled	Rifled
Tube Size in. [mm] OD	0.375 [9.5]	0.375 [9.5]	0.375 [9.5]	0.375 [9.5]
Face Area sq. ft. [sq. m]	16.56 [1.54]	16.56 [1.54]	16.56 [1.54]	16.56 [1.54]
Rows / FPI [FPcm]	2 / 22 [9]	2 / 22 [9]	2 / 22 [9]	2 / 22 [9]
<b>Indoor Coil—Fin Type</b>	Corrugated	Corrugated	Corrugated	Corrugated
Tube Type	Rifled	Rifled	Rifled	Rifled
Tube Size in. [mm]	0.375 [9.5]	0.375 [9.5]	0.375 [9.5]	0.375 [9.5]
Face Area sq. ft. [sq. m]	5.17 [0.48]	5.17 [0.48]	5.17 [0.48]	5.17 [0.48]
Rows / FPI [FPcm]	3 / 15 [6]	3 / 15 [6]	3 / 15 [6]	3 / 15 [6]
Refrigerant Control	TX Valves	TX Valves	TX Valves	TX Valves
Drain Connection No./Size in. [mm]	1/0.75 [19.05]	1/0.75 [19.05]	1/0.75 [19.05]	1/0.75 [19.05]
<b>Outdoor Fan—Type</b>	Propeller	Propeller	Propeller	Propeller
No. Used/Diameter in. [mm]	1/24 [609.6]	1/24 [609.6]	1/24 [609.6]	1/24 [609.6]
Drive Type/No. Speeds	Direct/1	Direct/1	Direct/1	Direct/1
CFM [L/s]	3680 [1737]	3680 [1737]	3680 [1737]	3680 [1737]
No. Motors/HP	1 at 1/3 HP	1 at 1/3 HP	1 at 1/3 HP	1 at 1/3 HP
Motor RPM	1075	1075	1075	1075
<b>Indoor Fan—Type</b>	FC Centrifugal	FC Centrifugal	FC Centrifugal	FC Centrifugal
No. Used/Diameter in. [mm]	1/10x10 [254x254]	1/10x10 [254x254]	1/10x10 [254x254]	1/10x10 [254x254]
Drive Type/No. Speeds	Belt/Variable	Direct/3	Direct/3	Direct/3
No. Motors	1	1	1	1
Motor HP	3/4	1/2	1/2	1/2
Motor RPM	1725	1075	1075	1075
Motor Frame Size	56	48	48	48
<b>Filter—Type</b>	Disposable	Disposable	Disposable	Disposable
Furnished	Yes	Yes	Yes	Yes
(No.) Size Recommended in. [mm]	(1)1x16x25 [25x406x635]	(1)1x16x25 [25x406x635]	(1)1x16x25 [25x406x635]	(1)1x16x25 [25x406x635]
	(1)1x16x25 [25x406x635]	(1)1x16x25 [25x406x635]	(1)1x16x25 [25x406x635]	(1)1x16x25 [25x406x635]
<b>Refrigerant Charge Oz. [g]</b>	167 [4734]	167 [4734]	167 [4734]	167 [4734]
<b>Weights</b>				
Net Weight lbs. [kg]	580 [263]	580 [263]	580 [263]	585 [265]
Ship Weight lbs. [kg]	587 [266]	587 [266]	587 [266]	592 [269]

See Page 26 for Notes.

[ ] Designates Metric Conversions



**NOM. SIZES 3-5 TONS [10.6-17.6 kW]**

Model RKNA- Series	A048DL08E	A048DL10E	A048DL13E	A048DM08E
<b>Cooling Performance<sup>1</sup></b>				<b>CONTINUED</b> →
Gross Cooling Capacity Btu [kW]	49,000 [14.36]	49,000 [14.36]	49,000 [14.36]	49,000 [14.36]
EER/SEER <sup>2</sup>	11.4/13.1	11.4/13.1	11.4/13.1	11.4/13.1
Nominal CFM/ARI Rated CFM [L/s]	1600/1550 [755/731]	1600/1550 [755/731]	1600/1550 [755/731]	1600/1550 [755/731]
ARI Net Cooling Capacity Btu [kW]	47,000 [13.77]	47,000 [13.77]	47,000 [13.77]	47,000 [13.77]
Net Sensible Capacity Btu [kW]	33,600 [9.84]	33,600 [9.84]	33,600 [9.84]	33,600 [9.84]
Net Latent Capacity Btu [kW]	13,400 [3.93]	13,400 [3.93]	13,400 [3.93]	13,400 [3.93]
Net System Power kW	4.15	4.15	4.15	4.15
<b>Heating Performance (Package Gas/Electric)<sup>3</sup></b>				
Heating Input Btu [kW]	80,000 [23.44]	100,000 [29.3]	135,000 [39.56]	80,000 [23.44]
Heating Output Btu [kW]	64,800 [18.99]	81,000 [23.73]	109,400 [32.05]	64,800 [18.99]
Temperature Rise Range °F [°C]	30-60 [16.7/33.3]	30-60 [16.7/33.3]	50-80 [27.8/44.4]	30-60 [16.7/33.3]
AFUE %	80	80	80	80
Steady State Efficiency (%)	81	81	81	81
No. Burners	4	5	6	4
No. Stages	1	1	1	1
Gas Connection Pipe Size in. [mm]	0.5 [12.7]	0.5 [12.7]	0.5 [12.7]	0.5 [12.7]
<b>Compressor</b>				
No./Type	1/Scroll	1/Scroll	1/Scroll	1/Scroll
<b>Outdoor Sound Rating (dB)</b>	78	78	78	78
<b>Outdoor Coil—Fin Type</b>	Louvered	Louvered	Louvered	Louvered
Tube Type	Rifled	Rifled	Rifled	Rifled
Tube Size in. [mm] OD	0.375 [9.5]	0.375 [9.5]	0.375 [9.5]	0.375 [9.5]
Face Area sq. ft. [sq. m]	16.56 [1.54]	16.56 [1.54]	16.56 [1.54]	16.56 [1.54]
Rows / FPI [FPcm]	2 / 22 [9]	2 / 22 [9]	2 / 22 [9]	2 / 22 [9]
<b>Indoor Coil—Fin Type</b>	Corrugated	Corrugated	Corrugated	Corrugated
Tube Type	Rifled	Rifled	Rifled	Rifled
Tube Size in. [mm]	0.375 [9.5]	0.375 [9.5]	0.375 [9.5]	0.375 [9.5]
Face Area sq. ft. [sq. m]	5.17 [0.48]	5.17 [0.48]	5.17 [0.48]	5.17 [0.48]
Rows / FPI [FPcm]	3 / 15 [6]	3 / 15 [6]	3 / 15 [6]	3 / 15 [6]
Refrigerant Control	TX Valves	TX Valves	TX Valves	TX Valves
Drain Connection No./Size in. [mm]	1/0.75 [19.05]	1/0.75 [19.05]	1/0.75 [19.05]	1/0.75 [19.05]
<b>Outdoor Fan—Type</b>	Propeller	Propeller	Propeller	Propeller
No. Used/Diameter in. [mm]	1/24 [609.6]	1/24 [609.6]	1/24 [609.6]	1/24 [609.6]
Drive Type/No. Speeds	Direct/1	Direct/1	Direct/1	Direct/1
CFM [L/s]	3680 [1737]	3680 [1737]	3680 [1737]	3680 [1737]
No. Motors/HP	1 at 1/3 HP	1 at 1/3 HP	1 at 1/3 HP	1 at 1/3 HP
Motor RPM	1075	1075	1075	1075
<b>Indoor Fan—Type</b>	FC Centrifugal	FC Centrifugal	FC Centrifugal	FC Centrifugal
No. Used/Diameter in. [mm]	1/10x10 [254x254]	1/10x10 [254x254]	1/10x10 [254x254]	1/10x10 [254x254]
Drive Type/No. Speeds	Belt/Variable	Belt/Variable	Belt/Variable	Belt/Variable
No. Motors	1	1	1	1
Motor HP	1/2	1/2	1/2	3/4
Motor RPM	1725	1725	1725	1725
Motor Frame Size	48	48	48	56
<b>Filter—Type</b>	Disposable	Disposable	Disposable	Disposable
Furnished	Yes	Yes	Yes	Yes
(No.) Size Recommended in. [mm]	(1)1x16x25 [25x406x635]	(1)1x16x25 [25x406x635]	(1)1x16x25 [25x406x635]	(1)1x16x25 [25x406x635]
	(1)1x16x25 [25x406x635]	(1)1x16x25 [25x406x635]	(1)1x16x25 [25x406x635]	(1)1x16x25 [25x406x635]
<b>Refrigerant Charge Oz. [g]</b>	167 [4734]	167 [4734]	167 [4734]	167 [4734]
<b>Weights</b>				
Net Weight lbs. [kg]	580 [263]	580 [263]	585 [265]	580 [263]
Ship Weight lbs. [kg]	587 [266]	587 [266]	592 [269]	587 [266]

See Page 26 for Notes.

[ ] Designates Metric Conversions



## NOM. SIZES 3-5 TONS [10.6-17.6 kW]

Model RKNA- Series	A048DM10E	A048DM13E	A048JK08E	A048JK08X
<b>Cooling Performance<sup>1</sup></b>				<b>CONTINUED</b> →
Gross Cooling Capacity Btu [kW]	49,000 [14.36]	49,000 [14.36]	49,000 [14.36]	49,000 [14.36]
EER/SEER <sup>2</sup>	11.4/13.1	11.4/13.1	11.4/13.1	11.4/13.1
Nominal CFM/ARI Rated CFM [L/s]	1600/1550 [755/731]	1600/1550 [755/731]	1600/1550 [755/731]	1600/1550 [755/731]
ARI Net Cooling Capacity Btu [kW]	47,000 [13.77]	47,000 [13.77]	47,000 [13.77]	47,000 [13.77]
Net Sensible Capacity Btu [kW]	33,600 [9.84]	33,600 [9.84]	33,600 [9.84]	33,600 [9.84]
Net Latent Capacity Btu [kW]	13,400 [3.93]	13,400 [3.93]	13,400 [3.93]	13,400 [3.93]
Net System Power kW	4.15	4.15	4.15	4.15
<b>Heating Performance (Package Gas/Electric)<sup>3</sup></b>				
Heating Input Btu [kW]	100,000 [29.3]	135,000 [39.56]	80,000 [23.44]	80,000 [23.44]
Heating Output Btu [kW]	81,000 [23.73]	109,400 [32.05]	62,500 [18.31]	62,500 [18.31]
Temperature Rise Range °F [°C]	30-60 [16.7/33.3]	50-80 [27.8/44.4]	30-60 [16.7/33.3]	30-60 [16.7/33.3]
AFUE %	80	80	80	80
Steady State Efficiency (%)	81	81	81	81
No. Burners	5	6	4	4
No. Stages	1	1	1	1
Gas Connection Pipe Size in. [mm]	0.5 [12.7]	0.5 [12.7]	0.5 [12.7]	0.5 [12.7]
<b>Compressor</b>				
No./Type	1/Scroll	1/Scroll	1/Scroll	1/Scroll
<b>Outdoor Sound Rating (dB)</b>	78	78	78	78
<b>Outdoor Coil—Fin Type</b>	Louvered	Louvered	Louvered	Louvered
Tube Type	Rifled	Rifled	Rifled	Rifled
Tube Size in. [mm] OD	0.375 [9.5]	0.375 [9.5]	0.375 [9.5]	0.375 [9.5]
Face Area sq. ft. [sq. m]	16.56 [1.54]	16.56 [1.54]	16.56 [1.54]	16.56 [1.54]
Rows / FPI [FPcm]	2 / 22 [9]	2 / 22 [9]	2 / 22 [9]	2 / 22 [9]
<b>Indoor Coil—Fin Type</b>	Corrugated	Corrugated	Corrugated	Corrugated
Tube Type	Rifled	Rifled	Rifled	Rifled
Tube Size in. [mm]	0.375 [9.5]	0.375 [9.5]	0.375 [9.5]	0.375 [9.5]
Face Area sq. ft. [sq. m]	5.17 [0.48]	5.17 [0.48]	5.17 [0.48]	5.17 [0.48]
Rows / FPI [FPcm]	3 / 15 [6]	3 / 15 [6]	3 / 15 [6]	3 / 15 [6]
Refrigerant Control	TX Valves	TX Valves	TX Valves	TX Valves
Drain Connection No./Size in. [mm]	1/0.75 [19.05]	1/0.75 [19.05]	1/0.75 [19.05]	1/0.75 [19.05]
<b>Outdoor Fan—Type</b>	Propeller	Propeller	Propeller	Propeller
No. Used/Diameter in. [mm]	1/24 [609.6]	1/24 [609.6]	1/24 [609.6]	1/24 [609.6]
Drive Type/No. Speeds	Direct/1	Direct/1	Direct/1	Direct/1
CFM [L/s]	3680 [1737]	3680 [1737]	3680 [1737]	3680 [1737]
No. Motors/HP	1 at 1/3 HP	1 at 1/3 HP	1 at 1/3 HP	1 at 1/3 HP
Motor RPM	1075	1075	1075	1075
<b>Indoor Fan—Type</b>	FC Centrifugal	FC Centrifugal	FC Centrifugal	FC Centrifugal
No. Used/Diameter in. [mm]	1/10x10 [254x254]	1/10x10 [254x254]	1/10x10 [254x254]	1/10x10 [254x254]
Drive Type/No. Speeds	Belt/Variable	Belt/Variable	Direct/3	Direct/3
No. Motors	1	1	1	1
Motor HP	3/4	3/4	1/2	1/2
Motor RPM	1725	1725	1075	1075
Motor Frame Size	56	56	48	48
<b>Filter—Type</b>	Disposable	Disposable	Disposable	Disposable
Furnished	Yes	Yes	Yes	Yes
(No.) Size Recommended in. [mm]	(1)1x16x25 [25x406x635]	(1)1x16x25 [25x406x635]	(1)1x16x25 [25x406x635]	(1)1x16x25 [25x406x635]
	(1)1x16x25 [25x406x635]	(1)1x16x25 [25x406x635]	(1)1x16x25 [25x406x635]	(1)1x16x25 [25x406x635]
<b>Refrigerant Charge Oz. [g]</b>	167 [4734]	167 [4734]	167 [4734]	167 [4734]
<b>Weights</b>				
Net Weight lbs. [kg]	580 [263]	580 [263]	580 [263]	580 [263]
Ship Weight lbs. [kg]	587 [266]	587 [266]	587 [266]	587 [266]

See Page 26 for Notes.

[ ] Designates Metric Conversions



## NOM. SIZES 3-5 TONS [10.6-17.6 kW]

Model RKNA- Series	A048JK10E	A048JK10X	A048JK13E	A048JK13X
<b>Cooling Performance<sup>1</sup></b>				<b>CONTINUED</b> →
Gross Cooling Capacity Btu [kW]	49,000 [14.36]	49,000 [14.36]	49,000 [14.36]	49,000 [14.36]
EER/SEER <sup>2</sup>	11.4/13.1	11.4/13.1	11.4/13.1	11.4/13.1
Nominal CFM/ARI Rated CFM [L/s]	1600/1550 [755/731]	1600/1550 [755/731]	1600/1550 [755/731]	1600/1550 [755/731]
ARI Net Cooling Capacity Btu [kW]	47,000 [13.77]	47,000 [13.77]	47,000 [13.77]	47,000 [13.77]
Net Sensible Capacity Btu [kW]	33,600 [9.84]	33,600 [9.84]	33,600 [9.84]	33,600 [9.84]
Net Latent Capacity Btu [kW]	13,400 [3.93]	13,400 [3.93]	13,400 [3.93]	13,400 [3.93]
Net System Power kW	4.15	4.15	4.15	4.15
<b>Heating Performance (Package Gas/Electric)<sup>3</sup></b>				
Heating Input Btu [kW]	100,000 [29.3]	100,000 [29.3]	135,000 [39.56]	135,000 [39.56]
Heating Output Btu [kW]	78,500 [23]	78,500 [23]	106,500 [31.2]	106,500 [31.2]
Temperature Rise Range °F [°C]	40-70 [22.2/38.9]	40-70 [22.2/38.9]	50-80 [27.8/44.4]	50-80 [27.8/44.4]
AFUE %	80	80	80	80
Steady State Efficiency (%)	81	81	81	81
No. Burners	5	5	6	6
No. Stages	1	1	1	1
Gas Connection Pipe Size in. [mm]	0.5 [12.7]	0.5 [12.7]	0.5 [12.7]	0.5 [12.7]
<b>Compressor</b>				
No./Type	1/Scroll	1/Scroll	1/Scroll	1/Scroll
<b>Outdoor Sound Rating (dB)</b>	78	78	78	78
<b>Outdoor Coil—Fin Type</b>	Louvered	Louvered	Louvered	Louvered
Tube Type	Rifled	Rifled	Rifled	Rifled
Tube Size in. [mm] OD	0.375 [9.5]	0.375 [9.5]	0.375 [9.5]	0.375 [9.5]
Face Area sq. ft. [sq. m]	16.56 [1.54]	16.56 [1.54]	16.56 [1.54]	16.56 [1.54]
Rows / FPI [FPcm]	2 / 22 [9]	2 / 22 [9]	2 / 22 [9]	2 / 22 [9]
<b>Indoor Coil—Fin Type</b>	Corrugated	Corrugated	Corrugated	Corrugated
Tube Type	Rifled	Rifled	Rifled	Rifled
Tube Size in. [mm]	0.375 [9.5]	0.375 [9.5]	0.375 [9.5]	0.375 [9.5]
Face Area sq. ft. [sq. m]	5.17 [0.48]	5.17 [0.48]	5.17 [0.48]	5.17 [0.48]
Rows / FPI [FPcm]	3 / 15 [6]	3 / 15 [6]	3 / 15 [6]	3 / 15 [6]
Refrigerant Control	TX Valves	TX Valves	TX Valves	TX Valves
Drain Connection No./Size in. [mm]	1/0.75 [19.05]	1/0.75 [19.05]	1/0.75 [19.05]	1/0.75 [19.05]
<b>Outdoor Fan—Type</b>	Propeller	Propeller	Propeller	Propeller
No. Used/Diameter in. [mm]	1/24 [609.6]	1/24 [609.6]	1/24 [609.6]	1/24 [609.6]
Drive Type/No. Speeds	Direct/1	Direct/1	Direct/1	Direct/1
CFM [L/s]	3680 [1737]	3680 [1737]	3680 [1737]	3680 [1737]
No. Motors/HP	1 at 1/3 HP	1 at 1/3 HP	1 at 1/3 HP	1 at 1/3 HP
Motor RPM	1075	1075	1075	1075
<b>Indoor Fan—Type</b>	FC Centrifugal	FC Centrifugal	FC Centrifugal	FC Centrifugal
No. Used/Diameter in. [mm]	1/10x10 [254x254]	1/10x10 [254x254]	1/10x10 [254x254]	1/10x10 [254x254]
Drive Type/No. Speeds	Direct/3	Direct/3	Direct/3	Direct/3
No. Motors	1	1	1	1
Motor HP	1/2	1/2	1/2	1/2
Motor RPM	1075	1075	1075	1075
Motor Frame Size	48	48	48	48
<b>Filter—Type</b>	Disposable	Disposable	Disposable	Disposable
Furnished	Yes	Yes	Yes	Yes
(No.) Size Recommended in. [mm]	(1)1x16x25 [25x406x635]	(1)1x16x25 [25x406x635]	(1)1x16x25 [25x406x635]	(1)1x16x25 [25x406x635]
	(1)1x16x25 [25x406x635]	(1)1x16x25 [25x406x635]	(1)1x16x25 [25x406x635]	(1)1x16x25 [25x406x635]
<b>Refrigerant Charge Oz. [g]</b>	167 [4734]	167 [4734]	167 [4734]	167 [4734]
<b>Weights</b>				
Net Weight lbs. [kg]	580 [263]	580 [263]	585 [265]	585 [265]
Ship Weight lbs. [kg]	587 [266]	587 [266]	592 [269]	592 [269]

See Page 26 for Notes.

[ ] Designates Metric Conversions



## NOM. SIZES 3-5 TONS [10.6-17.6 kW]

Model RKNA- Series	A060CK10E	A060CK13E	A060CL10E	A060CL13E
<b>Cooling Performance<sup>1</sup></b>				
Gross Cooling Capacity Btu [kW]	60,000 [17.58]	60,000 [17.58]	60,000 [17.58]	60,000 [17.58]
EER/SEER <sup>2</sup>	11.6/13	11.6/13	11.6/13	11.6/13
Nominal CFM/ARI Rated CFM [L/s]	2000/1900 [897/897]	2000/1900 [897/897]	2000/1900 [897/897]	2000/1900 [897/897]
ARI Net Cooling Capacity Btu [kW]	58,000 [16.99]	58,000 [16.99]	58,000 [16.99]	58,000 [16.99]
Net Sensible Capacity Btu [kW]	42,000 [12.31]	42,000 [12.31]	42,000 [12.31]	42,000 [12.31]
Net Latent Capacity Btu [kW]	16,000 [4.69]	16,000 [4.69]	16,000 [4.69]	16,000 [4.69]
Net System Power kW	5	5	5	5
<b>Heating Performance (Package Gas/Electric)<sup>3</sup></b>				
Heating Input Btu [kW]	100,000 [29.3]	135,000 [39.56]	100,000 [29.3]	135,000 [39.56]
Heating Output Btu [kW]	81,000 [23.73]	109,400 [32.05]	81,000 [23.73]	109,400 [32.05]
Temperature Rise Range °F [°C]	25-55 [13.9/30.6]	40-70 [22.2/38.9]	25-55 [13.9/30.6]	40-70 [22.2/38.9]
AFUE %	80	80	80	80
Steady State Efficiency (%)	81	81	81	81
No. Burners	5	6	5	6
No. Stages	1	1	1	1
Gas Connection Pipe Size in. [mm]	0.5 [12.7]	0.5 [12.7]	0.5 [12.7]	0.5 [12.7]
<b>Compressor</b>				
No./Type	1/Scroll	1/Scroll	1/Scroll	1/Scroll
<b>Outdoor Sound Rating (dB)</b>				
	83	83	83	83
<b>Outdoor Coil—Fin Type</b>				
Tube Type	Louvered	Louvered	Louvered	Louvered
Tube Size in. [mm] OD	Rifled	Rifled	Rifled	Rifled
Face Area sq. ft. [sq. m]	0.375 [9.5]	0.375 [9.5]	0.375 [9.5]	0.375 [9.5]
Rows / FPI [FPcm]	16.56 [1.54]	16.56 [1.54]	16.56 [1.54]	16.56 [1.54]
	2 / 22 [9]	2 / 22 [9]	2 / 22 [9]	2 / 22 [9]
<b>Indoor Coil—Fin Type</b>				
Tube Type	Corrugated	Corrugated	Corrugated	Corrugated
Tube Size in. [mm]	Rifled	Rifled	Rifled	Rifled
Face Area sq. ft. [sq. m]	0.375 [9.5]	0.375 [9.5]	0.375 [9.5]	0.375 [9.5]
Rows / FPI [FPcm]	5.17 [0.48]	5.17 [0.48]	5.17 [0.48]	5.17 [0.48]
	3 / 15 [6]	3 / 15 [6]	3 / 15 [6]	3 / 15 [6]
Refrigerant Control	TX Valves	TX Valves	TX Valves	TX Valves
Drain Connection No./Size in. [mm]	1/0.75 [19.05]	1/0.75 [19.05]	1/0.75 [19.05]	1/0.75 [19.05]
<b>Outdoor Fan—Type</b>				
No. Used/Diameter in. [mm]	Propeller	Propeller	Propeller	Propeller
Drive Type/No. Speeds	1/24 [609.6]	1/24 [609.6]	1/24 [609.6]	1/24 [609.6]
CFM [L/s]	Direct/1	Direct/1	Direct/1	Direct/1
No. Motors/HP	3930 [1855]	3930 [1855]	3930 [1855]	3930 [1855]
Motor RPM	1 at 1/3 HP	1 at 1/3 HP	1 at 1/3 HP	1 at 1/3 HP
	1075	1075	1075	1075
<b>Indoor Fan—Type</b>				
No. Used/Diameter in. [mm]	FC Centrifugal	FC Centrifugal	FC Centrifugal	FC Centrifugal
Drive Type/No. Speeds	1/10x10 [254x254]	1/10x10 [254x254]	1/10x10 [254x254]	1/10x10 [254x254]
No. Motors	Direct/3	Direct/3	Belt/Variable	Belt/Variable
Motor HP	1	1	1	1
Motor RPM	1	1	3/4	3/4
Motor Frame Size	1075	1075	1725	1725
	48	48	56	56
<b>Filter—Type</b>				
Furnished	Disposable	Disposable	Disposable	Disposable
(No.) Size Recommended in. [mm]	Yes	Yes	Yes	Yes
	(1)1x16x25 [25x406x635]	(1)1x16x25 [25x406x635]	(1)1x16x25 [25x406x635]	(1)1x16x25 [25x406x635]
	(1)1x16x25 [25x406x635]	(1)1x16x25 [25x406x635]	(1)1x16x25 [25x406x635]	(1)1x16x25 [25x406x635]
<b>Refrigerant Charge Oz. [g]</b>				
	160 [4536]	160 [4536]	160 [4536]	160 [4536]
<b>Weights</b>				
Net Weight lbs. [kg]	590 [268]	597 [271]	590 [268]	597 [271]
Ship Weight lbs. [kg]	597 [271]	604 [274]	597 [271]	604 [274]

**CONTINUED** →

See Page 26 for Notes.

[ ] Designates Metric Conversions



**NOM. SIZES 3-5 TONS [10.6-17.6 kW]**

Model RKNA- Series	A060CM10E	A060CM13E	A060DL10E	A060DL13E
<b>Cooling Performance<sup>1</sup></b>				<b>CONTINUED →</b>
Gross Cooling Capacity Btu [kW]	60,000 [17.58]	60,000 [17.58]	60,000 [17.58]	60,000 [17.58]
EER/SEER <sup>2</sup>	11.6/13	11.6/13	11.6/13	11.6/13
Nominal CFM/ARI Rated CFM [L/s]	2000/1900 [897/897]	2000/1900 [897/897]	2000/1900 [897/897]	2000/1900 [897/897]
ARI Net Cooling Capacity Btu [kW]	58,000 [16.99]	58,000 [16.99]	58,000 [16.99]	58,000 [16.99]
Net Sensible Capacity Btu [kW]	42,000 [12.31]	42,000 [12.31]	42,000 [12.31]	42,000 [12.31]
Net Latent Capacity Btu [kW]	16,000 [4.69]	16,000 [4.69]	16,000 [4.69]	16,000 [4.69]
Net System Power kW	5	5	5	5
<b>Heating Performance (Package Gas/Electric)<sup>3</sup></b>				
Heating Input Btu [kW]	100,000 [29.3]	135,000 [39.56]	100,000 [29.3]	135,000 [39.56]
Heating Output Btu [kW]	81,000 [23.73]	109,400 [32.05]	81,000 [23.73]	109,400 [32.05]
Temperature Rise Range °F [°C]	25-55 [13.9/30.6]	40-70 [22.2/38.9]	25-55 [13.9/30.6]	40-70 [22.2/38.9]
AFUE %	80	80	80	80
Steady State Efficiency (%)	81	81	81	81
No. Burners	5	6	5	6
No. Stages	1	1	1	1
Gas Connection Pipe Size in. [mm]	0.5 [12.7]	0.5 [12.7]	0.5 [12.7]	0.5 [12.7]
<b>Compressor</b>				
No./Type	1/Scroll	1/Scroll	1/Scroll	1/Scroll
<b>Outdoor Sound Rating (dB)</b>				
	83	83	83	83
<b>Outdoor Coil—Fin Type</b>				
Tube Type	Louvered	Louvered	Louvered	Louvered
Tube Size in. [mm] OD	Rifled	Rifled	Rifled	Rifled
Face Area sq. ft. [sq. m]	0.375 [9.5]	0.375 [9.5]	0.375 [9.5]	0.375 [9.5]
Rows / FPI [FPcm]	16.56 [1.54]	16.56 [1.54]	16.56 [1.54]	16.56 [1.54]
	2 / 22 [9]	2 / 22 [9]	2 / 22 [9]	2 / 22 [9]
<b>Indoor Coil—Fin Type</b>				
Tube Type	Corrugated	Corrugated	Corrugated	Corrugated
Tube Size in. [mm]	Rifled	Rifled	Rifled	Rifled
Face Area sq. ft. [sq. m]	0.375 [9.5]	0.375 [9.5]	0.375 [9.5]	0.375 [9.5]
Rows / FPI [FPcm]	5.17 [0.48]	5.17 [0.48]	5.17 [0.48]	5.17 [0.48]
	3 / 15 [6]	3 / 15 [6]	3 / 15 [6]	3 / 15 [6]
Refrigerant Control	TX Valves	TX Valves	TX Valves	TX Valves
Drain Connection No./Size in. [mm]	1/0.75 [19.05]	1/0.75 [19.05]	1/0.75 [19.05]	1/0.75 [19.05]
<b>Outdoor Fan—Type</b>				
	Propeller	Propeller	Propeller	Propeller
No. Used/Diameter in. [mm]	1/24 [609.6]	1/24 [609.6]	1/24 [609.6]	1/24 [609.6]
Drive Type/No. Speeds	Direct/1	Direct/1	Direct/1	Direct/1
CFM [L/s]	3930 [1855]	3930 [1855]	3930 [1855]	3930 [1855]
No. Motors/HP	1 at 1/3 HP	1 at 1/3 HP	1 at 1/3 HP	1 at 1/3 HP
Motor RPM	1075	1075	1075	1075
<b>Indoor Fan—Type</b>				
	FC Centrifugal	FC Centrifugal	FC Centrifugal	FC Centrifugal
No. Used/Diameter in. [mm]	1/10x10 [254x254]	1/10x10 [254x254]	1/10x10 [254x254]	1/10x10 [254x254]
Drive Type/No. Speeds	Belt/Variable	Belt/Variable	Belt/Variable	Belt/Variable
No. Motors	1	1	1	1
Motor HP	1	1	3/4	3/4
Motor RPM	1725	1725	1725	1725
Motor Frame Size	56	56	56	56
<b>Filter—Type</b>				
	Disposable	Disposable	Disposable	Disposable
Furnished	Yes	Yes	Yes	Yes
(No.) Size Recommended in. [mm]	(1)1x16x25 [25x406x635]	(1)1x16x25 [25x406x635]	(1)1x16x25 [25x406x635]	(1)1x16x25 [25x406x635]
	(1)1x16x25 [25x406x635]	(1)1x16x25 [25x406x635]	(1)1x16x25 [25x406x635]	(1)1x16x25 [25x406x635]
<b>Refrigerant Charge Oz. [g]</b>				
	160 [4536]	160 [4536]	160 [4536]	160 [4536]
<b>Weights</b>				
Net Weight lbs. [kg]	590 [268]	590 [268]	590 [268]	597 [271]
Ship Weight lbs. [kg]	597 [271]	597 [271]	597 [271]	604 [274]

See Page 26 for Notes.

[ ] Designates Metric Conversions



## NOM. SIZES 3-5 TONS [10.6-17.6 kW]

Model RKNA- Series	A060DM10E	A060DM13E	A060JK10E	A060JK10X
<b>Cooling Performance<sup>1</sup></b>				
Gross Cooling Capacity Btu [kW]	60,000 [17.58]	60,000 [17.58]	60,000 [17.58]	60,000 [17.58]
EER/SEER <sup>2</sup>	11.6/13	11.6/13	11.6/13	11.6/13
Nominal CFM/ARI Rated CFM [L/s]	2000/1900 [897/897]	2000/1900 [897/897]	2000/1900 [897/897]	2000/1900 [897/897]
ARI Net Cooling Capacity Btu [kW]	58,000 [16.99]	58,000 [16.99]	58,000 [16.99]	58,000 [16.99]
Net Sensible Capacity Btu [kW]	42,000 [12.31]	42,000 [12.31]	42,000 [12.31]	42,000 [12.31]
Net Latent Capacity Btu [kW]	16,000 [4.69]	16,000 [4.69]	16,000 [4.69]	16,000 [4.69]
Net System Power kW	5	5	5	5
<b>Heating Performance (Package Gas/Electric)<sup>3</sup></b>				
Heating Input Btu [kW]	100,000 [29.3]	135,000 [39.56]	100,000 [29.3]	100,000 [29.3]
Heating Output Btu [kW]	81,000 [23.73]	109,400 [32.05]	78,500 [23]	78,500 [23]
Temperature Rise Range °F [°C]	25-55 [13.9/30.6]	40-70 [22.2/38.9]	25-55 [13.9/30.6]	25-55 [13.9/30.6]
AFUE %	80	80	80	80
Steady State Efficiency (%)	81	81	81	81
No. Burners	5	6	5	5
No. Stages	1	1	1	1
Gas Connection Pipe Size in. [mm]	0.5 [12.7]	0.5 [12.7]	0.5 [12.7]	0.5 [12.7]
<b>Compressor</b>				
No./Type	1/Scroll	1/Scroll	1/Scroll	1/Scroll
<b>Outdoor Sound Rating (dB)</b>				
	83	83	83	83
<b>Outdoor Coil—Fin Type</b>				
Tube Type	Louvered	Louvered	Louvered	Louvered
Tube Size in. [mm] OD	Rifled	Rifled	Rifled	Rifled
Tube Size in. [mm] OD	0.375 [9.5]	0.375 [9.5]	0.375 [9.5]	0.375 [9.5]
Face Area sq. ft. [sq. m]	16.56 [1.54]	16.56 [1.54]	16.56 [1.54]	16.56 [1.54]
Rows / FPI [FPcm]	2 / 22 [9]	2 / 22 [9]	2 / 22 [9]	2 / 22 [9]
<b>Indoor Coil—Fin Type</b>				
Tube Type	Corrugated	Corrugated	Corrugated	Corrugated
Tube Type	Rifled	Rifled	Rifled	Rifled
Tube Size in. [mm]	0.375 [9.5]	0.375 [9.5]	0.375 [9.5]	0.375 [9.5]
Face Area sq. ft. [sq. m]	5.17 [0.48]	5.17 [0.48]	5.17 [0.48]	5.17 [0.48]
Rows / FPI [FPcm]	3 / 15 [6]	3 / 15 [6]	3 / 15 [6]	3 / 15 [6]
Refrigerant Control	TX Valves	TX Valves	TX Valves	TX Valves
Drain Connection No./Size in. [mm]	1/0.75 [19.05]	1/0.75 [19.05]	1/0.75 [19.05]	1/0.75 [19.05]
<b>Outdoor Fan—Type</b>				
Propeller	Propeller	Propeller	Propeller	Propeller
No. Used/Diameter in. [mm]	1/24 [609.6]	1/24 [609.6]	1/24 [609.6]	1/24 [609.6]
Drive Type/No. Speeds	Direct/1	Direct/1	Direct/1	Direct/1
CFM [L/s]	3930 [1855]	3930 [1855]	3930 [1855]	3930 [1855]
No. Motors/HP	1 at 1/3 HP	1 at 1/3 HP	1 at 1/3 HP	1 at 1/3 HP
Motor RPM	1075	1075	1075	1075
<b>Indoor Fan—Type</b>				
FC Centrifugal	FC Centrifugal	FC Centrifugal	FC Centrifugal	FC Centrifugal
No. Used/Diameter in. [mm]	1/10x10 [254x254]	1/10x10 [254x254]	1/10x10 [254x254]	1/10x10 [254x254]
Drive Type/No. Speeds	Belt/Variable	Belt/Variable	Direct/3	Direct/3
No. Motors	1	1	1	1
Motor HP	1	1	1	1
Motor RPM	1725	1725	1075	1075
Motor Frame Size	56	56	48	48
<b>Filter—Type</b>				
Disposable	Disposable	Disposable	Disposable	Disposable
Furnished	Yes	Yes	Yes	Yes
(No.) Size Recommended in. [mm]	(1)1x16x25 [25x406x635]	(1)1x16x25 [25x406x635]	(1)1x16x25 [25x406x635]	(1)1x16x25 [25x406x635]
	(1)1x16x25 [25x406x635]	(1)1x16x25 [25x406x635]	(1)1x16x25 [25x406x635]	(1)1x16x25 [25x406x635]
<b>Refrigerant Charge Oz. [g]</b>				
	160 [4536]	160 [4536]	160 [4536]	160 [4536]
<b>Weights</b>				
Net Weight lbs. [kg]	590 [268]	590 [268]	590 [268]	590 [268]
Ship Weight lbs. [kg]	597 [271]	597 [271]	597 [271]	597 [271]

See Page 26 for Notes.

[ ] Designates Metric Conversions

**NOM. SIZES 3-5 TONS [10.6-17.6 kW]**

<b>Model RKNA- Series</b>	<b>A060JK13E</b>	<b>A060JK13X</b>
<b>Cooling Performance<sup>1</sup></b>		
Gross Cooling Capacity Btu [kW]	60,000 [17.58]	60,000 [17.58]
EER/SEER <sup>2</sup>	11.6/13	11.6/13
Nominal CFM/ARI Rated CFM [L/s]	2000/1900 [897/897]	2000/1900 [897/897]
ARI Net Cooling Capacity Btu [kW]	58,000 [16.99]	58,000 [16.99]
Net Sensible Capacity Btu [kW]	42,000 [12.31]	42,000 [12.31]
Net Latent Capacity Btu [kW]	16,000 [4.69]	16,000 [4.69]
Net System Power kW	5	5
<b>Heating Performance (Package Gas/Electric)<sup>3</sup></b>		
Heating Input Btu [kW]	135,000 [39.56]	135,000 [39.56]
Heating Output Btu [kW]	106,500 [31.2]	106,500 [31.2]
Temperature Rise Range °F [°C]	40-70 [22.2/38.9]	40-70 [22.2/38.9]
AFUE %	80	80
Steady State Efficiency (%)	81	81
No. Burners	6	6
No. Stages	1	1
Gas Connection Pipe Size in. [mm]	0.5 [12.7]	0.5 [12.7]
<b>Compressor</b>		
No./Type	1/Scroll	1/Scroll
<b>Outdoor Sound Rating (dB)</b>		
	83	83
<b>Outdoor Coil—Fin Type</b>		
Tube Type	Louvered	Louvered
Tube Size in. [mm] OD	Rifled	Rifled
Tube Size in. [mm] OD	0.375 [9.5]	0.375 [9.5]
Face Area sq. ft. [sq. m]	16.56 [1.54]	16.56 [1.54]
Rows / FPI [FPcm]	2 / 22 [9]	2 / 22 [9]
<b>Indoor Coil—Fin Type</b>		
Tube Type	Corrugated	Corrugated
Tube Type	Rifled	Rifled
Tube Size in. [mm]	0.375 [9.5]	0.375 [9.5]
Face Area sq. ft. [sq. m]	5.17 [0.48]	5.17 [0.48]
Rows / FPI [FPcm]	3 / 15 [6]	3 / 15 [6]
Refrigerant Control	TX Valves	TX Valves
Drain Connection No./Size in. [mm]	1/0.75 [19.05]	1/0.75 [19.05]
<b>Outdoor Fan—Type</b>		
	Propeller	Propeller
No. Used/Diameter in. [mm]	1/24 [609.6]	1/24 [609.6]
Drive Type/No. Speeds	Direct/1	Direct/1
CFM [L/s]	3930 [1855]	3930 [1855]
No. Motors/HP	1 at 1/3 HP	1 at 1/3 HP
Motor RPM	1075	1075
<b>Indoor Fan—Type</b>		
	FC Centrifugal	FC Centrifugal
No. Used/Diameter in. [mm]	1/10x10 [254x254]	1/10x10 [254x254]
Drive Type/No. Speeds	Direct/3	Direct/3
No. Motors	1	1
Motor HP	1	1
Motor RPM	1075	1075
Motor Frame Size	48	48
<b>Filter—Type</b>		
	Disposable	Disposable
Furnished	Yes	Yes
(No.) Size Recommended in. [mm]	(1)1x16x25 [25x406x635]	(1)1x16x25 [25x406x635]
	(1)1x16x25 [25x406x635]	(1)1x16x25 [25x406x635]
<b>Refrigerant Charge Oz. [g]</b>		
	160 [4536]	160 [4536]
<b>Weights</b>		
Net Weight lbs. [kg]	597 [271]	597 [271]
Ship Weight lbs. [kg]	604 [274]	604 [274]

See Page 26 for Notes.

[ ] Designates Metric Conversions



## NOTES:

1. Cooling Performance is rated at 95° F ambient, 80° F entering dry bulb, 67° F entering wet bulb. Gross capacity does not include the effect of fan motor heat. ARI capacity is net and includes the effect of fan motor heat. Units are suitable for operation to  $\pm 20\%$  of nominal cfm. Units are certified in accordance with the Unitary Air Conditioner Equipment certification program, which is based on ARI Standard 210/240 or 360.
2. EER and/or SEER are rated at ARI conditions and in accordance with DOE test procedures.
3. Heating Performance limit settings and rating data were established and approved under laboratory test conditions using American National Standard Institute standards. Ratings shown are for elevations up to 2000 feet. For elevations above 2000 feet, ratings should be reduced at the rate of 4% for each 1000 feet above sea level.



## GROSS SYSTEMS PERFORMANCE DATA—A036

		ENTERING INDOOR AIR @ 80°F [26.7°C] dbE ①									
wbE		71°F [21.7°C]			67°F [19.4°C]			63°F [17.2°C]			
CFM [L/s]		1500 [707.9]	1200 [566.3]	900 [424.8]	1500 [707.9]	1200 [566.3]	900 [424.8]	1500 [707.9]	1200 [566.3]	900 [424.8]	
DR ①		.16	.12	.06	.16	.12	.06	.16	.12	.06	
OUTDOOR DRY BULB TEMPERATURE °F [°C]	75 [23.9]	Total BTUH [kW] Sens BTUH [kW] Power	45.5 [13.33] 27.9 [8.18] 2.2	43.5 [12.75] 24.9 [7.30] 2.2	41.6 [12.19] 22.0 [6.45] 2.1	42.7 [12.51] 33.1 [9.70] 2.2	40.9 [11.99] 29.7 [8.70] 2.1	39.0 [11.43] 26.2 [7.68] 2.1	40.3 [11.81] 37.6 [11.02] 2.2	38.6 [11.31] 33.7 [9.88] 2.1	36.8 [10.79] 29.8 [8.73] 2.1
	80 [26.7]	Total BTUH [kW] Sens BTUH [kW] Power	44.6 [13.07] 27.2 [7.97] 2.3	42.6 [12.48] 24.4 [7.15] 2.3	40.7 [11.93] 21.5 [6.30] 2.2	41.8 [12.25] 32.5 [9.52] 2.3	40.0 [11.72] 29.1 [8.53] 2.3	38.1 [11.17] 25.7 [7.53] 2.2	39.4 [11.55] 37.0 [10.84] 2.3	37.7 [11.05] 33.2 [9.73] 2.3	35.9 [10.52] 29.3 [8.59] 2.2
	85 [29.4]	Total BTUH [kW] Sens BTUH [kW] Power	43.7 [12.81] 26.7 [7.83] 2.5	41.8 [12.25] 23.9 [7.00] 2.4	39.9 [11.69] 21.1 [6.18] 2.4	40.9 [11.99] 32.0 [9.38] 2.4	39.1 [11.46] 28.7 [8.41] 2.4	37.4 [10.96] 25.3 [7.41] 2.3	38.5 [11.28] 36.5 [10.70] 2.4	36.8 [10.79] 32.7 [9.58] 2.4	35.1 [10.29] 28.9 [8.47] 2.3
	90 [32.2]	Total BTUH [kW] Sens BTUH [kW] Power	42.9 [12.57] 26.3 [7.71] 2.6	41.0 [12.02] 23.6 [6.92] 2.5	39.1 [11.46] 20.8 [6.10] 2.5	40.1 [11.75] 31.6 [9.26] 2.6	38.3 [11.22] 28.3 [8.29] 2.5	36.6 [10.73] 25.0 [7.33] 2.5	37.6 [11.02] 36.1 [10.58] 2.6	36.0 [10.55] 32.3 [9.47] 2.5	34.4 [10.08] 28.5 [8.35] 2.5
	95 [35]	Total BTUH [kW] Sens BTUH [kW] Power	42.0 [12.31] 25.9 [7.59] 2.7	40.2 [11.78] 23.2 [6.80] 2.6	38.3 [11.22] 20.5 [6.01] 2.6	39.2 [11.49] 31.1 [9.11] 2.7	37.5 [10.99] 27.9 [8.18] 2.6	35.8 [10.49] 24.6 [7.21] 2.6	36.8 [10.79] 35.7 [10.46] 2.7	35.2 [10.32] 31.9 [9.35] 2.6	33.6 [9.85] 28.2 [8.26] 2.6
	100 [37.8]	Total BTUH [kW] Sens BTUH [kW] Power	41.1 [12.05] 25.4 [7.44] 2.8	39.3 [11.52] 22.8 [6.68] 2.8	37.5 [10.99] 20.1 [5.89] 2.7	38.3 [11.22] 30.7 [9.00] 2.8	36.6 [10.73] 27.5 [8.06] 2.8	34.9 [10.23] 24.3 [7.12] 2.7	35.8 [10.49] 35.2 [10.32] 2.8	34.3 [10.05] 31.5 [9.23] 2.8	32.7 [9.58] 27.8 [8.15] 2.7
	105 [40.6]	Total BTUH [kW] Sens BTUH [kW] Power	40.0 [11.72] 24.9 [7.30] 3.0	38.3 [11.22] 22.3 [6.54] 2.9	36.5 [10.70] 19.7 [5.77] 2.8	37.2 [10.90] 30.1 [8.82] 3.0	35.6 [10.43] 27.0 [7.91] 2.9	34.0 [9.96] 23.8 [6.98] 2.8	34.8 [10.20] 34.7 [10.17] 2.9	33.3 [9.76] 31.0 [9.09] 2.9	31.8 [9.32] 27.4 [8.03] 2.8
	110 [43.3]	Total BTUH [kW] Sens BTUH [kW] Power	38.8 [11.37] 24.2 [7.09] 3.1	37.1 [10.87] 21.7 [6.36] 3.0	35.4 [10.37] 19.1 [5.60] 3.0	36.0 [10.55] 29.4 [8.62] 3.1	34.4 [10.08] 26.4 [7.74] 3.0	32.8 [9.61] 23.3 [6.83] 3.0	33.6 [9.85] 33.6 [9.85] 3.1	32.1 [9.41] 30.4 [8.91] 3.0	30.6 [8.97] 26.9 [7.88] 2.9
	115 [46.1]	Total BTUH [kW] Sens BTUH [kW] Power	37.3 [10.93] 23.3 [6.83] 3.2	35.7 [10.46] 20.9 [6.13] 3.1	34.1 [9.99] 18.4 [5.39] 3.1	34.5 [10.11] 28.6 [8.38] 3.2	33.0 [9.67] 25.6 [7.50] 3.1	31.5 [9.23] 22.6 [6.62] 3.1	32.1 [9.41] 32.1 [9.41] 3.2	30.7 [9.00] 29.6 [8.67] 3.1	29.3 [8.59] 26.2 [7.68] 3.1

## GROSS SYSTEMS PERFORMANCE DATA—A042

		ENTERING INDOOR AIR @ 80°F [26.7°C] dbE ①									
wbE		71°F [21.7°C]			67°F [19.4°C]			63°F [17.2°C]			
CFM [L/s]		1810 [854.2]	1450 [684.3]	1090 [514.4]	1810 [854.2]	1450 [684.3]	1090 [514.4]	1810 [854.2]	1450 [684.3]	1090 [514.4]	
DR ①		.23	.2	.15	.23	.2	.15	.23	.2	.15	
OUTDOOR DRY BULB TEMPERATURE °F [°C]	75 [23.9]	Total BTUH [kW] Sens BTUH [kW] Power	53.2 [15.59] 32.4 [9.50] 2.5	50.9 [14.92] 29.1 [8.53] 2.5	48.6 [14.24] 25.7 [7.53] 2.4	49.3 [14.45] 38.2 [11.20] 2.5	47.1 [13.80] 34.2 [10.02] 2.5	45.0 [13.19] 30.2 [8.85] 2.4	46.0 [13.48] 43.6 [12.78] 2.5	44.0 [12.90] 39.0 [11.43] 2.5	42.0 [12.31] 34.5 [10.11] 2.4
	80 [26.7]	Total BTUH [kW] Sens BTUH [kW] Power	51.9 [15.21] 31.9 [9.35] 2.7	49.6 [14.54] 28.6 [8.38] 2.6	47.4 [13.89] 25.2 [7.39] 2.6	48.0 [14.07] 37.7 [11.05] 2.7	45.9 [13.45] 33.8 [9.91] 2.6	43.8 [12.84] 29.8 [8.73] 2.6	44.7 [13.10] 43.0 [12.60] 2.7	42.7 [12.51] 38.5 [11.28] 2.6	40.8 [11.96] 34.0 [9.96] 2.6
	85 [29.4]	Total BTUH [kW] Sens BTUH [kW] Power	50.8 [14.89] 31.3 [9.17] 2.8	48.6 [14.24] 28.0 [8.21] 2.8	46.4 [13.60] 24.7 [7.24] 2.7	46.8 [13.72] 37.1 [10.87] 2.8	44.8 [13.13] 33.2 [9.73] 2.7	42.8 [12.54] 29.3 [8.59] 2.7	43.6 [12.78] 42.4 [12.43] 2.8	41.7 [12.22] 38.0 [11.14] 2.7	39.8 [11.66] 33.5 [9.82] 2.7
	90 [32.2]	Total BTUH [kW] Sens BTUH [kW] Power	49.8 [14.59] 30.6 [8.97] 3.0	47.6 [13.95] 27.4 [8.03] 2.9	45.4 [13.31] 24.2 [7.09] 2.8	45.8 [13.42] 36.4 [10.67] 2.9	43.8 [12.84] 32.6 [9.55] 2.9	41.9 [12.28] 28.8 [8.44] 2.8	42.6 [12.48] 41.7 [12.22] 2.9	40.7 [11.93] 37.4 [10.96] 2.9	38.9 [11.40] 33.0 [9.67] 2.8
	95 [35]	Total BTUH [kW] Sens BTUH [kW] Power	48.8 [14.30] 29.9 [8.76] 3.1	46.7 [13.69] 26.7 [7.83] 3.0	44.6 [13.07] 23.6 [6.92] 3.0	44.9 [13.16] 35.7 [10.46] 3.1	42.9 [12.57] 31.9 [9.35] 3.0	41.0 [12.02] 28.2 [8.26] 3.0	41.6 [12.19] 41.0 [12.02] 3.1	39.8 [11.66] 36.7 [10.76] 3.0	38.0 [11.14] 32.4 [9.50] 3.0
	100 [37.8]	Total BTUH [kW] Sens BTUH [kW] Power	47.8 [14.01] 29.2 [8.56] 3.3	45.7 [13.39] 26.1 [7.65] 3.2	43.7 [12.81] 23.1 [6.77] 3.1	43.9 [12.87] 35.0 [10.26] 3.2	42.0 [12.31] 31.3 [9.17] 3.2	40.1 [11.75] 27.7 [8.12] 3.1	40.6 [11.90] 40.3 [11.81] 3.2	38.9 [11.40] 36.1 [10.58] 3.2	37.1 [10.87] 31.9 [9.35] 3.1
	105 [40.6]	Total BTUH [kW] Sens BTUH [kW] Power	46.8 [13.72] 28.6 [8.38] 3.4	44.7 [13.10] 25.6 [7.50] 3.3	42.7 [12.51] 22.6 [6.62] 3.3	42.8 [12.54] 34.4 [10.08] 3.4	41.0 [12.02] 30.8 [9.03] 3.3	39.1 [11.46] 27.2 [7.97] 3.2	39.6 [11.61] 39.6 [11.61] 3.4	37.8 [11.08] 35.6 [10.43] 3.3	36.1 [10.58] 31.4 [9.20] 3.2
	110 [43.3]	Total BTUH [kW] Sens BTUH [kW] Power	45.5 [13.33] 28.1 [8.24] 3.5	43.5 [12.75] 25.1 [7.36] 3.5	41.6 [12.19] 22.2 [6.51] 3.4	41.6 [12.19] 33.9 [9.94] 3.5	39.8 [11.66] 30.3 [8.88] 3.4	38.0 [11.14] 26.8 [7.85] 3.4	38.3 [11.22] 38.3 [11.22] 3.5	36.7 [10.76] 35.1 [10.29] 3.4	35.0 [10.26] 31.0 [9.09] 3.4
	115 [46.1]	Total BTUH [kW] Sens BTUH [kW] Power	44.1 [12.92] 27.7 [8.12] 3.7	42.1 [12.34] 24.8 [7.27] 3.6	40.2 [11.78] 21.9 [6.42] 3.5	40.1 [11.75] 33.5 [9.82] 3.6	38.4 [11.25] 30.0 [8.79] 3.6	36.7 [10.76] 26.5 [7.77] 3.5	36.9 [10.81] 36.9 [10.81] 3.6	35.3 [10.35] 34.8 [10.20] 3.6	33.7 [9.88] 30.7 [9.00] 3.5

DR —Depression ratio  
dbE—Entering air dry bulb  
wbE—Entering air wet bulb

Total —Total capacity x 1000 BTUH  
Sens —Sensible capacity x 1000 BTUH  
Power—KW input

NOTES: ① When the entering air dry bulb is other than 80°F [27°C], adjust the sensible capacity from the table by adding [(1.10 x CFM x (1 - DR) x (dbE - 80))].

[ ] Designates Metric Conversions



## GROSS SYSTEMS PERFORMANCE DATA—A048

		ENTERING INDOOR AIR @ 80°F [26.7°C] dbE ①									
wbE		71°F [21.7°C]			67°F [19.4°C]			63°F [17.2°C]			
CFM [L/s]		1940 [915.5]	1550 [731.5]	1160 [547.4]	1940 [915.5]	1550 [731.5]	1160 [547.4]	1940 [915.5]	1550 [731.5]	1160 [547.4]	
DR ①		.21	.18	.14	.21	.18	.14	.21	.18	.14	
OUTDOOR DRY BULB TEMPERATURE °F [°C]	75 [23.9]	Total BTUH [kW] Sens BTUH [kW] Power	62.9 [18.43] 38.2 [11.20] 2.9	60.2 [17.64] 34.2 [10.02] 2.9	57.5 [16.85] 30.2 [8.85] 2.8	57.6 [16.88] 43.8 [12.84] 2.9	55.1 [16.15] 39.2 [11.49] 2.8	52.6 [15.42] 34.6 [10.14] 2.8	55.7 [16.32] 51.4 [15.06] 2.9	53.3 [15.62] 46.0 [13.48] 2.8	50.9 [14.92] 40.6 [11.90] 2.7
	80 [26.7]	Total BTUH [kW] Sens BTUH [kW] Power	61.0 [17.88] 36.6 [10.73] 3.1	58.4 [17.12] 32.8 [9.61] 3.0	55.7 [16.32] 29.0 [8.50] 3.0	55.7 [16.32] 42.2 [12.37] 3.1	53.3 [15.62] 37.8 [11.08] 3.0	50.9 [14.92] 33.4 [9.79] 2.9	53.8 [15.77] 49.8 [14.59] 3.0	51.5 [15.09] 44.6 [13.07] 3.0	49.1 [14.39] 39.4 [11.55] 2.9
	85 [29.4]	Total BTUH [kW] Sens BTUH [kW] Power	59.3 [17.38] 35.5 [10.40] 3.3	56.8 [16.65] 31.8 [9.32] 3.2	54.2 [15.88] 28.1 [8.24] 3.1	54.1 [15.86] 41.1 [12.05] 3.2	51.7 [15.15] 36.8 [10.79] 3.2	49.4 [14.48] 32.5 [9.52] 3.1	52.2 [15.30] 48.7 [14.27] 3.2	49.9 [14.62] 43.6 [12.78] 3.1	47.6 [13.95] 38.5 [11.28] 3.1
	90 [32.2]	Total BTUH [kW] Sens BTUH [kW] Power	57.9 [16.97] 34.8 [10.20] 3.4	55.4 [16.24] 31.2 [9.14] 3.4	52.9 [15.50] 27.5 [8.06] 3.3	52.6 [15.42] 40.4 [11.84] 3.4	50.3 [14.74] 36.2 [10.61] 3.4	48.0 [14.07] 31.9 [9.35] 3.3	50.7 [14.86] 48.0 [14.07] 3.4	48.5 [14.21] 43.0 [12.60] 3.3	46.3 [13.57] 37.9 [11.11] 3.3
	95 [35]	Total BTUH [kW] Sens BTUH [kW] Power	56.7 [16.62] 34.3 [10.05] 3.6	54.2 [15.88] 30.7 [9.00] 3.6	51.7 [15.15] 27.2 [7.97] 3.5	51.4 [15.06] 39.9 [11.69] 3.6	49.1 [14.39] 35.7 [10.46] 3.5	46.9 [13.75] 31.6 [9.26] 3.5	49.5 [14.51] 47.5 [13.92] 3.6	47.3 [13.86] 42.5 [12.46] 3.5	45.2 [13.25] 37.6 [11.02] 3.4
	100 [37.8]	Total BTUH [kW] Sens BTUH [kW] Power	55.5 [16.27] 34.0 [9.96] 3.8	53.1 [15.56] 30.4 [8.91] 3.7	50.7 [14.86] 26.9 [7.88] 3.6	50.3 [14.74] 39.6 [11.61] 3.8	48.1 [14.10] 35.4 [10.37] 3.7	45.9 [13.45] 31.3 [9.17] 3.6	48.4 [14.18] 47.2 [13.83] 3.7	46.3 [13.57] 42.2 [12.37] 3.7	44.2 [12.95] 37.3 [10.93] 3.6
	105 [40.6]	Total BTUH [kW] Sens BTUH [kW] Power	54.5 [15.97] 33.7 [9.88] 4.0	52.2 [15.30] 30.2 [8.85] 3.9	49.8 [14.59] 26.6 [7.80] 3.8	49.3 [14.45] 39.3 [11.52] 4.0	47.1 [13.80] 35.2 [10.32] 3.9	45.0 [13.19] 31.1 [9.11] 3.8	47.4 [13.89] 46.9 [13.75] 3.9	45.3 [13.28] 42.0 [12.31] 3.8	43.2 [12.66] 37.1 [10.87] 3.8
	110 [43.3]	Total BTUH [kW] Sens BTUH [kW] Power	53.6 [15.71] 33.3 [9.76] 4.2	51.3 [15.03] 29.8 [8.73] 4.1	49.0 [14.36] 26.3 [7.71] 4.0	48.3 [14.16] 38.8 [11.37] 4.1	46.2 [13.54] 34.8 [10.20] 4.0	44.1 [12.92] 30.7 [9.00] 4.0	46.4 [13.60] 46.4 [13.60] 4.1	44.4 [13.01] 41.6 [12.19] 4.0	42.4 [12.43] 36.7 [10.76] 3.9
	115 [46.1]	Total BTUH [kW] Sens BTUH [kW] Power	52.7 [15.44] 32.6 [9.55] 4.3	50.4 [14.77] 29.2 [8.56] 4.2	48.1 [14.10] 25.8 [7.56] 4.2	47.4 [13.89] 38.2 [11.20] 4.3	45.4 [13.31] 34.2 [10.02] 4.2	43.3 [12.69] 30.2 [8.85] 4.1	45.5 [13.33] 45.5 [13.33] 4.3	43.6 [12.78] 41.0 [12.02] 4.2	41.6 [12.19] 36.2 [10.61] 4.1

## GROSS SYSTEMS PERFORMANCE DATA—A060

		ENTERING INDOOR AIR @ 80°F [26.7°C] dbE ①									
wbE		71°F [21.7°C]			67°F [19.4°C]			63°F [17.2°C]			
CFM [L/s]		2380 [1123.2]	1900 [896.7]	1420 [670.1]	2380 [1123.2]	1900 [896.7]	1420 [670.1]	2380 [1123.2]	1900 [896.7]	1420 [670.1]	
DR ①		.20	.17	.12	.20	.17	.12	.20	.17	.12	
OUTDOOR DRY BULB TEMPERATURE °F [°C]	75 [23.9]	Total BTUH [kW] Sens BTUH [kW] Power	73.0 [21.39] 44.0 [12.90] 3.7	69.8 [20.46] 39.4 [11.55] 3.6	66.6 [19.52] 34.8 [10.20] 3.6	68.1 [19.96] 52.1 [15.27] 3.7	65.2 [19.11] 46.7 [13.69] 3.6	62.2 [18.23] 41.2 [12.07] 3.5	64.2 [18.82] 60.0 [17.58] 3.6	61.4 [17.99] 53.7 [15.74] 3.5	58.6 [17.17] 47.5 [13.92] 3.5
	80 [26.7]	Total BTUH [kW] Sens BTUH [kW] Power	72.0 [21.10] 43.3 [12.69] 3.9	68.9 [20.19] 38.8 [11.37] 3.8	65.8 [19.28] 34.2 [10.02] 3.8	67.2 [19.69] 51.4 [15.06] 3.9	64.2 [18.82] 46.0 [13.48] 3.8	61.3 [17.97] 40.7 [11.93] 3.7	63.2 [18.52] 59.3 [17.38] 3.8	60.5 [17.73] 53.1 [15.56] 3.7	57.7 [16.91] 46.9 [13.75] 3.7
	85 [29.4]	Total BTUH [kW] Sens BTUH [kW] Power	70.7 [20.72] 42.6 [12.48] 4.1	67.7 [19.84] 38.1 [11.17] 4.0	64.6 [18.93] 33.7 [9.88] 4.0	65.9 [19.31] 50.7 [14.86] 4.1	63.0 [18.46] 45.4 [13.31] 4.0	60.2 [17.64] 40.1 [11.75] 3.9	61.9 [18.14] 58.6 [17.17] 4.0	59.3 [17.38] 52.4 [15.36] 3.9	56.6 [16.59] 46.3 [13.57] 3.9
	90 [32.2]	Total BTUH [kW] Sens BTUH [kW] Power	69.3 [20.31] 41.8 [12.25] 4.3	66.2 [19.40] 37.5 [10.99] 4.2	63.2 [18.52] 33.1 [9.70] 4.2	64.4 [18.87] 49.9 [14.62] 4.3	61.6 [18.05] 44.7 [13.10] 4.2	58.8 [17.23] 39.5 [11.58] 4.1	60.5 [17.73] 57.8 [16.94] 4.2	57.8 [16.94] 51.8 [15.18] 4.1	55.2 [16.18] 45.7 [13.39] 4.1
	95 [35]	Total BTUH [kW] Sens BTUH [kW] Power	67.6 [19.81] 41.1 [12.05] 4.5	64.7 [18.96] 36.8 [10.79] 4.5	61.7 [18.08] 32.5 [9.52] 4.4	62.8 [18.40] 49.2 [14.42] 4.5	60.0 [17.58] 44.0 [12.90] 4.4	57.3 [16.79] 38.9 [11.40] 4.3	58.8 [17.23] 57.1 [16.73] 4.4	56.3 [16.50] 51.1 [14.98] 4.4	53.7 [15.74] 45.2 [13.25] 4.3
	100 [37.8]	Total BTUH [kW] Sens BTUH [kW] Power	65.9 [19.31] 40.3 [11.81] 4.8	63.1 [18.49] 36.1 [10.58] 4.7	60.2 [17.64] 31.9 [9.35] 4.6	61.1 [17.91] 48.4 [14.18] 4.7	58.4 [17.12] 43.4 [12.72] 4.6	55.8 [16.35] 38.3 [11.22] 4.5	57.1 [16.73] 56.3 [16.50] 4.7	54.7 [16.03] 50.4 [14.77] 4.6	52.2 [15.30] 44.5 [13.04] 4.5
	105 [40.6]	Total BTUH [kW] Sens BTUH [kW] Power	64.3 [18.84] 39.5 [11.58] 5.0	61.5 [18.02] 35.4 [10.37] 4.9	58.7 [17.20] 31.3 [9.17] 4.8	59.4 [17.41] 47.6 [13.95] 4.9	56.9 [16.68] 42.6 [12.48] 4.8	54.3 [15.91] 37.7 [11.05] 4.7	55.5 [16.27] 49.7 [14.57] 4.9	53.1 [15.56] 49.7 [14.57] 4.8	50.7 [14.86] 43.9 [12.87] 4.7
	110 [43.3]	Total BTUH [kW] Sens BTUH [kW] Power	62.8 [18.40] 38.7 [11.34] 5.2	60.0 [17.58] 34.6 [10.14] 5.1	57.3 [16.79] 30.6 [8.97] 5.0	57.9 [16.97] 46.8 [13.72] 5.1	55.4 [16.24] 41.9 [12.28] 5.0	52.9 [15.50] 37.0 [10.84] 4.9	54.0 [15.83] 54.0 [15.83] 5.1	51.6 [15.12] 49.0 [14.36] 5.0	49.3 [14.45] 43.3 [12.69] 4.9
	115 [46.1]	Total BTUH [kW] Sens BTUH [kW] Power	61.4 [17.99] 37.8 [11.08] 5.4	58.8 [17.23] 33.9 [9.94] 5.3	56.1 [16.44] 29.9 [8.76] 5.2	56.6 [16.59] 45.9 [13.45] 5.3	54.1 [15.86] 41.1 [12.05] 5.2	51.7 [15.15] 36.3 [10.64] 5.1	52.6 [15.42] 52.6 [15.42] 5.3	50.3 [14.74] 48.2 [14.13] 5.2	48.0 [14.07] 42.6 [12.48] 5.1

DR —Depression ratio  
dbE—Entering air dry bulb  
wbE—Entering air wet bulb

Total —Total capacity x 1000 BTUH  
Sens —Sensible capacity x 1000 BTUH  
Power—KW input

NOTES: ① When the entering air dry bulb is other than 80°F [27°C], adjust the sensible capacity from the table by adding  $[1.10 \times \text{CFM} \times (1 - \text{DR}) \times (\text{dbE} - 80)]$ .

[ ] Designates Metric Conversions



# AIRFLOW PERFORMANCE—DIRECT DRIVE RKNA- SERIES

## DIRECT-DRIVE 208 AIRFLOW PERFORMANCE

Unit Model	Motor Speed From Factory		Heating Input BTU/hr [kW]	Manufacturer Recommended Air-Flow Range (Min/Max) CFM	Blower Size/ Motor HP [W] # of Speeds	Motor Speed	CFM [L/s] Air Delivery/RPM/Watts—208 Volts								
	Cool	Heat					External Static Pressure—Inches W.C. [kPa]								
							0.1 [.02]	0.2 [.05]	0.3 [.07]	0.4 [.10]	0.5 [.12]	0.6 [.15]	0.7 [.17]	0.8 [.20]	
RKNA-A036	Low	Low	80,000 [23.45]	1050/1350	10x10 1/2 HP [373] 3 Speed Motor	Low	CFM	1210 [571]	1193 [563]	1175 [555]	1155 [545]	1125 [531]	1075 [507]	1015 [479]	925 [437]
		Watts	450				400	395	385	380	375	370	360		
		Med	120,000 [35.17]				CFM	1515 [715]	1500 [708]	1475 [696]	1450 [684]	1405 [663]	1350 [637]	1275 [602]	1180 [557]
RKNA-A042	Med	Med	120,000 [35.17]	1225/1575	10x10 1/2 HP [373] 3 Speed Motor	Med	CFM	1680 [793]	1650 [779]	1625 [767]	1580 [746]	1530 [722]	1460 [689]	1390 [656]	1280 [604]
		Watts	650				640	630	610	580	560	545	515		
		High	135,000 [39.56]				CFM	1210 [571]	1193 [563]	1175 [555]	1155 [545]	1125 [531]	1075 [507]	1015 [479]	925 [437]
RKNA-A048	High	High	135,000 [39.56]	1400/1800	10x10 1/2 HP [373] 3 Speed Motor	High	CFM	1680 [793]	1650 [779]	1625 [767]	1580 [746]	1530 [722]	1460 [689]	1390 [656]	1280 [604]
		Watts	650				640	630	610	580	560	545	515		
		Low	80,000 [23.45]				CFM	1515 [715]	1500 [708]	1475 [696]	1450 [684]	1405 [663]	1350 [637]	1275 [602]	1180 [557]
RKNA-A060	Med	Med	100,000 [29.31]	1750/2250	10x10 1 HP [745] 3 Speed Motor	Med	CFM	1575 [743]	1536 [725]	1496 [706]	1457 [688]	1417 [669]	1377 [650]	1338 [631]	1298 [613]
		Watts	297				314	330	347	364	381	397	414		
		High	135,000 [39.56]				CFM	1985 [937]	1954 [922]	1919 [906]	1876 [885]	1824 [861]	1759 [830]	1679 [792]	1581 [746]
RKNA-A060	High	High	135,000 [39.56]	1750/2250	10x10 1 HP [745] 3 Speed Motor	High	CFM	2431 [1147]	2372 [1119]	2306 [1088]	2228 [1051]	2138 [1009]	2032 [959]	1907 [900]	1762 [832]
		Watts	970				981	964	926	872	806	736	665		

[ ] Designates Metric Conversions



## DIRECT-DRIVE 230 AIRFLOW PERFORMANCE

Unit Model	Motor Speed From Factory		Heating Input BTU/hr [kW]	Manufacturer Recommended Air-Flow Range (Min/Max) CFM	Blower Size/ Motor HP [w] # of Speeds	Motor Speed	CFM [L/s] Air Delivery/RPM/Watts—230 Volts									
	Cool	Heat					External Static Pressure—Inches W.C. [kPa]									
							0.1 [.02]	0.2 [.05]	0.3 [.07]	0.4 [.10]	0.5 [.12]	0.6 [.15]	0.7 [.17]	0.8 [.20]		
RKNA-A036	Low	Med	80,000 [23.45]	1050/1350	10x10 1/2 HP [373] 3 Speed Motor	Low	CFM	1400 [661]	1375 [649]	1360 [642]	1335 [630]	1305 [616]	1255 [592]	1210 [571]	1100 [519]	
			Watts				470	460	455	450	440	435	425	410		
			CFM				1685 [795]	1620 [765]	1580 [746]	1550 [732]	1500 [708]	1430 [675]	1350 [637]	1230 [580]		
	Med	High	CFM				1870 [883]	1830 [864]	1790 [845]	1730 [816]	1660 [783]	1580 [746]	1500 [708]	1375 [649]		
			Watts				780	760	740	700	660	635	600	555		
			CFM				1400 [661]	1375 [649]	1360 [642]	1335 [630]	1305 [616]	1255 [592]	1210 [571]	1100 [519]		
RKNA-A042	Med	Med	80,000 [23.45]	1225/1575	10x10 1/2 HP [373] 3 Speed Motor	Med	CFM	1685 [795]	1620 [765]	1580 [746]	1550 [732]	1500 [708]	1430 [675]	1350 [637]	1230 [580]	
			Watts				635	600	580	570	550	535	505	475		
			CFM				1870 [883]	1830 [864]	1790 [845]	1730 [816]	1660 [783]	1580 [746]	1500 [708]	1375 [649]		
	Low	High	CFM				1400 [661]	1375 [649]	1360 [642]	1335 [630]	1305 [616]	1255 [592]	1210 [571]	1100 [519]		
			Watts				470	460	455	450	440	435	425	410		
			CFM				1685 [795]	1620 [765]	1580 [746]	1550 [732]	1500 [708]	1430 [675]	1350 [637]	1230 [580]		
RKNA-A048	Med	High	80,000 [23.45]	1400/1800	10x10 1/2 HP [373] 3 Speed Motor	High	CFM	1870 [883]	1830 [864]	1790 [845]	1730 [816]	1660 [783]	1580 [746]	1500 [708]	1375 [649]	
			Watts				780	760	740	700	660	635	600	555		
			CFM				1400 [661]	1375 [649]	1360 [642]	1335 [630]	1305 [616]	1255 [592]	1210 [571]	1100 [519]		
	Low	Med	CFM				1575 [743]	1536 [725]	1496 [706]	1457 [688]	1417 [669]	1377 [650]	1338 [631]	1298 [613]		
			Watts				297	314	330	347	364	381	397	414		
			CFM				1985 [937]	1954 [922]	1919 [906]	1876 [885]	1824 [861]	1759 [830]	1679 [792]	1581 [746]		
RKNA-A060	Med	High	100,000 [29.31]	1750/2250	10x10 1 HP [745] 3 Speed Motor	High	CFM	1870 [883]	1830 [864]	1790 [845]	1730 [816]	1660 [783]	1580 [746]	1500 [708]	1375 [649]	
			Watts				780	760	740	700	660	635	600	555		
			CFM				1400 [661]	1375 [649]	1360 [642]	1335 [630]	1305 [616]	1255 [592]	1210 [571]	1100 [519]		
	Low	Med	CFM				1575 [743]	1536 [725]	1496 [706]	1457 [688]	1417 [669]	1377 [650]	1338 [631]	1298 [613]		
			Watts				297	314	330	347	364	381	397	414		
			CFM				1985 [937]	1954 [922]	1919 [906]	1876 [885]	1824 [861]	1759 [830]	1679 [792]	1581 [746]		
High	High	CFM	2431 [1147]	2372 [1119]	2306 [1088]	2228 [1051]	2138 [1009]	2032 [959]	1907 [900]	1762 [832]						
		Watts	970	981	964	926	872	806	736	665						
		CFM	1400 [661]	1375 [649]	1360 [642]	1335 [630]	1305 [616]	1255 [592]	1210 [571]	1100 [519]						

[ ] Designates Metric Conversions



## DIRECT-DRIVE 460 AIRFLOW PERFORMANCE

Unit Model	Motor Speed From Factory		Heating Input BTU/hr [KW]	Manufacturer Recommended Air-Flow Range (Min/Max) CFM	Blower Size/ Motor HP [W] # of Speeds	Motor Speed	CFM [L/s] Air Delivery/RPM/Watts—460 Volts								
	Cool	Heat					External Static Pressure—Inches W.C. [kPa]								
							0.1 [.02]	0.2 [.05]	0.3 [.07]	0.4 [.10]	0.5 [.12]	0.6 [.15]	0.7 [.17]	0.8 [.20]	
RKNA-A036	Low	Low	80,000	1050/1350	10x10 1/2 HP [373] 3 Speed Motor	Low	CFM	1400 [661]	1375 [649]	1360 [642]	1335 [630]	1305 [616]	1255 [592]	1210 [571]	1100 [519]
			Watts				470	460	455	450	440	435	425	410	
			CFM				1685 [795]	1620 [765]	1580 [746]	1550 [732]	1500 [708]	1430 [675]	1350 [637]	1230 [580]	
	Med	Med	80,000	1225/1575	10x10 1/2 HP [373] 3 Speed Motor	Med	CFM	1685 [795]	1620 [765]	1580 [746]	1550 [732]	1500 [708]	1430 [675]	1350 [637]	1230 [580]
			Watts				635	600	580	570	550	535	505	475	
			CFM				1870 [883]	1830 [864]	1790 [845]	1730 [816]	1660 [783]	1580 [746]	1500 [708]	1375 [649]	
High	High	100,000	1400/1800	10x10 1/2 HP [373] 3 Speed Motor	High	CFM	1870 [883]	1830 [864]	1790 [845]	1730 [816]	1660 [783]	1580 [746]	1500 [708]	1375 [649]	
		Watts				780	760	740	700	660	635	600	555		
		CFM				1400 [661]	1375 [649]	1360 [642]	1335 [630]	1305 [616]	1255 [592]	1210 [571]	1100 [519]		
High	High	135,000	1400/1800	10x10 1/2 HP [373] 3 Speed Motor	High	CFM	1685 [795]	1620 [765]	1580 [746]	1550 [732]	1500 [708]	1430 [675]	1350 [637]	1230 [580]	
		Watts				635	600	580	570	550	535	505	475		
		CFM				1870 [883]	1830 [864]	1790 [845]	1730 [816]	1660 [783]	1580 [746]	1500 [708]	1375 [649]		
High	High	139,560	1400/1800	10x10 1/2 HP [373] 3 Speed Motor	High	CFM	1870 [883]	1830 [864]	1790 [845]	1730 [816]	1660 [783]	1580 [746]	1500 [708]	1375 [649]	
		Watts				780	760	740	700	660	635	600	555		
		CFM				1400 [661]	1375 [649]	1360 [642]	1335 [630]	1305 [616]	1255 [592]	1210 [571]	1100 [519]		

[ ] Designates Metric Conversions



## AIRFLOW PERFORMANCE—3 TON [10.55 kW] GAS HEAT MODELS BELT DRIVE

Air Flow CFM [L/s]	Capacity 3 Ton [10.55 kW]—13 SEER		Voltage 208/230-460—3 Phase		External Static Pressure—Inches of Water [kPa]																									
	0.1 [.02]		0.2 [.05]		0.3 [.07]		0.4 [.10]		0.5 [.12]		0.6 [.15]		0.7 [.17]		0.8 [.20]		0.9 [.22]		1.0 [.25]		1.1 [.27]		1.2 [.30]		1.3 [.32]		1.4 [.35]		1.5 [.37]	
	RPM	W	RPM	W	RPM	W	RPM	W	RPM	W	RPM	W	RPM	W	RPM	W	RPM	W	RPM	W	RPM	W	RPM	W	RPM	W	RPM	W	RPM	W
900 [425]	—	—	—	—	650	230	715	260	780	290	845	340	905	400	960	455	1010	470	1055	490	1095	525	1140	555	1170	580	1215	625	1240	645
1000 [472]	—	—	615	225	670	255	740	280	800	320	860	375	925	425	980	470	1025	485	1075	515	1105	540	1155	575	1180	605	1225	650	1260	715
1100 [519]	—	—	630	255	700	275	760	310	820	345	885	390	940	435	995	485	1035	505	1085	540	1120	575	1170	615	1190	640	1235	690	1270	730
1200 [566]	605	250	655	270	720	305	775	340	835	370	900	415	955	475	1005	495	1045	540	1095	580	1130	605	1180	655	1210	690	1245	730	1290	780
1300 [614]	620	275	300	750	340	805	375	400	920	455	970	505	1025	530	1065	575	1115	610	1155	630	1195	680	1220	730	1255	780	1300	825	880	940
1400 [661]	640	305	710	340	775	375	825	395	880	440	940	480	990	520	1035	560	1080	590	1125	650	1170	705	1215	775	1230	810	1270	840	1320	880
1500 [708]	660	340	745	370	800	405	845	425	910	490	955	535	1005	565	1050	615	1090	660	1135	700	1185	760	1225	820	1240	850	1290	905	1330	940

NOTE: Bold lines separate L, M and N drives respectively.

Drive Package	L						M							
	1/2 [373]						3/4 [373]							
Motor H.P. [W]	6.9" Pitch Diameter						6.4" Pitch Diameter							
Blower Sheave	2.4"-3.4" Pitch Diameter						3.4"-4.4" Pitch Diameter							
Turns Open	0	1	2	3	4	5	6	0	1	2	3	4	5	6
RPM	920	855	800	750	705	665	605	1230	1180	1130	1090	1045	1000	940

NOTE: Factory sheave settings are shown in bold print.

## COMPONENT AIR RESISTANCE

Component	Standard Indoor Airflow—CFM [L/s]						Resistance—Inches Water [kPa]					
	1000 [472]	1200 [566]	1400 [661]	1600 [755]	1800 [850]	2000 [944]	2200 [1038]	2400 [1133]	2600 [1227]	2800 [1321]		
Wet Coil	.035	.040	.060	.070	.085	.100	.110	.120	.125	.130		
Downflow	.055	.060	.066	.072	.080	.086	.093	.100	.107	.115		
R.S.I. Economizer R.A. Damper	.05	.06	.07	.08	.09	.10	.11	.12	.13	.15		

### NOTES:

- Performance shown with dry coil & standard 1" [25.4 mm] filters
- Standard CFM @ .075 lbs./cu. ft.
- Motor efficiency = 80% on 208/230, 460, 575 V, 3-Phase  
Motor efficiency = 50% on 208/230 V, 1-Phase
- BHP =  $\frac{\text{Watts} \times \text{Motor Eff.}}{746}$
- Add component resistance to duct static to determine total E.S.P.

### [ ] Designates Metric Conversions



## AIRFLOW PERFORMANCE—3.5 TON [12.31 kW] BELT DRIVE

Air Flow CFM [L/s]	Capacity 3.5 Ton [12.31 kW]—13 SEER Voltage 208/230-460—3 Phase																									
	External Static Pressure—Inches of Water [kPa]																									
	0.1 [.02]	0.2 [.05]	0.3 [.07]	0.4 [.10]	0.5 [.12]	0.6 [.15]	0.7 [.17]	0.8 [.20]	0.9 [.22]	1.0 [.25]	1.1 [.27]	1.2 [.30]	1.3 [.32]	1.4 [.35]	1.5 [.37]											
1000 [425]	—	—	—	735	305	325	850	360	895	380	945	400	995	420	1060	455	1105	490	1145	520	1185	550	1220	590	1265	630
1100 [519]	—	—	—	750	320	355	870	380	915	400	965	415	1010	450	1075	500	1120	520	1160	560	1195	590	1240	640	1275	700
1200 [566]	—	—	725	335	370	350	835	380	885	410	935	440	985	450	1030	500	1090	540	1130	560	1170	600	1215	650	1255	710
1300 [614]	—	—	745	360	800	395	860	415	905	445	955	465	1005	510	1050	550	1105	590	1140	610	1180	650	1230	710	1270	790
1400 [661]	—	725	375	765	395	830	420	880	460	925	490	985	510	1015	1065	600	1120	640	1150	665	1190	710	1245	790	1325	900
1500 [708]	—	740	410	795	440	855	460	905	495	950	540	1000	590	1030	1100	1090	650	1135	690	1170	720	1205	765	1260	860	1310
1600 [755]	725	410	765	445	820	470	875	510	925	540	975	570	1015	1065	1105	700	1145	745	1185	800	1225	860	1275	915	1325	1005
1700 [802]	740	460	795	495	850	520	900	550	945	600	1000	650	1020	1070	1125	760	1165	810	1205	865	1240	940	1290	1005	1340	—
1800 [850]	770	500	825	535	875	570	925	605	980	650	1010	710	1045	750	1100	790	1145	835	1185	900	1225	960	1270	1020	1315	1110

NOTE: Bold lines separate L, M and N drives respectively.

Drive Package	L						M							
	Motor H.P. [W]	1/2 [373]						1/2 [373]						
Blower Sheave	6.9" Pitch Diameter						6.4" Pitch Diameter							
Motor Sheave	2.8"-3.8" Pitch Diameter						4.0"-5.0" Pitch Diameter							
Turns Open	0	1	2	3	4	5	6	0	1	2	3	4	5	6
RPM	958	945	905	865	820	770	725	1225	1185	1145	1100	1060	1020	1000

NOTE: Factory sheave settings are shown in bold print.

N Drive (Field Supplied)
Blower Sheave—6.4 Pitch Diameter
Motor Sheave—4.0-5.0 Pitch Diameter
RPM Range—1090-1365
Motor—1/2 H.P. [373 W]—1750 RPM

## AIRFLOW PERFORMANCE—4 TON [14.07 kW] BELT DRIVE

Air Flow CFM [L/s]	Capacity 4 Ton [14.07 kW]—13 SEER Voltage 208/230-460—3 Phase																									
	External Static Pressure—Inches of Water [kPa]																									
	0.1 [.02]	0.2 [.05]	0.3 [.07]	0.4 [.10]	0.5 [.12]	0.6 [.15]	0.7 [.17]	0.8 [.20]	0.9 [.22]	1.0 [.25]	1.1 [.27]	1.2 [.30]	1.3 [.32]	1.4 [.35]	1.5 [.37]											
1200 [566]	—	—	—	780	360	390	885	410	935	440	975	475	1015	505	1070	550	1120	570	1170	600	1220	635	1265	655	1320	705
1300 [614]	—	—	—	805	390	855	410	910	450	950	470	990	510	1030	545	1085	590	1135	610	1185	640	1235	685	1285	730	1335
1400 [661]	—	—	770	385	825	425	870	445	925	480	960	510	1010	550	1050	600	1105	615	1155	650	1200	700	1245	730	1300	1345
1500 [708]	—	—	790	425	850	475	900	490	940	515	980	550	1025	600	1075	640	1125	670	1175	700	1220	745	1270	780	1315	825
1600 [755]	—	775	425	815	455	870	495	920	530	960	560	1005	605	1050	680	1145	710	1195	755	1235	800	1285	845	1330	890	1370
1700 [802]	—	795	470	850	505	900	540	940	560	980	605	1025	655	1075	715	1120	735	1165	770	1215	810	1270	870	1305	915	1385
1800 [850]	775	470	820	515	875	555	930	600	960	625	1010	680	1050	740	1100	800	1190	840	1235	890	1280	930	1330	985	1365	1020
1900 [897]	800	525	855	560	910	610	955	650	995	700	1035	755	1075	800	1130	840	1175	870	1220	920	955	1305	1010	1350	1070	1385
2000 [944]	830	595	885	640	940	670	970	710	1020	790	1065	840	1115	860	1160	900	1200	950	1240	1010	1295	1060	1330	1105	1375	1160

NOTE: L-Drive left of bold line, M-Drive right of bold line.

Drive Package	L						M							
	Motor H.P. [W]	1/2 [373]						3/4 [559]						
Blower Sheave	6.4" Pitch Diameter						5.7" Pitch Diameter							
Motor Sheave	2.8"-3.8" Pitch Diameter						3.4"-4.4" Pitch Diameter							
Turns Open	0	1	2	3	4	5	6	0	1	2	3	4	5	6
RPM	1060	1000	955	910	865	825	770	1385	1330	1280	1225	1175	1120	1060

NOTE: Factory sheave settings are shown in bold print.

[ ] Designates Metric Conversions



## AIRFLOW PERFORMANCE—5 TON [17.6 kW] THREE PHASE BELT DRIVE

Air Flow CFM [L/s]	Capacity 5 Ton [17.6 kW]—13 SEER		External Static Pressure—Inches of Water [kPa]																													
	Voltage 208/230-460—3 Phase		0.1 [.02]		0.2 [.05]		0.3 [.07]		0.4 [.10]		0.5 [.12]		0.6 [.15]		0.7 [1.17]		0.8 [.20]		0.9 [.22]		1.0 [.25]		1.1 [1.27]		1.2 [1.30]		1.3 [1.32]		1.4 [1.35]		1.5 [1.37]	
	RPM	W	RPM	W	RPM	W	RPM	W	RPM	W	RPM	W	RPM	W	RPM	W	RPM	W	RPM	W	RPM	W	RPM	W	RPM	W	RPM	W	RPM	W		
1400 [661]	—	—	—	—	—	—	—	—	—	—	—	—	—	—	—	—	—	—	—	—	—	—	—	—	—	—	—	—	—	—		
1500 [708]	—	—	—	—	—	—	—	—	—	—	—	—	—	—	—	—	—	—	—	—	—	—	—	—	—	—	—	—	—	—	—	
1600 [755]	—	—	—	—	—	—	—	—	—	—	—	—	—	—	—	—	—	—	—	—	—	—	—	—	—	—	—	—	—	—	—	
1700 [802]	—	—	—	—	—	—	—	—	—	—	—	—	—	—	—	—	—	—	—	—	—	—	—	—	—	—	—	—	—	—	—	
1800 [850]	780	455	815	470	870	540	915	560	965	615	1010	660	1055	710	1100	760	1140	785	1175	810	1225	850	1260	880	1320	930	1365	985	1390	1020		
1900 [897]	800	485	850	530	895	590	945	640	995	675	1035	720	1070	775	1120	810	1160	850	1200	890	1245	915	1290	960	1335	1000	1375	1050	1405	1100		
2000 [944]	830	550	880	605	930	655	970	700	1015	730	1055	790	1105	830	1145	875	1180	910	1225	950	1260	980	1320	1035	1350	1075	1385	1120	—	—		
2100 [991]	860	615	915	665	965	705	1005	760	1040	820	1090	870	1130	910	1170	950	1210	995	1250	1020	1290	1060	1335	1100	1370	1150	1400	1200	—	—		
2200 [1038]	895	680	945	735	995	780	1030	830	1060	880	1120	940	1155	980	1195	1020	1240	1055	1275	1100	1320	1140	1360	1180	1385	1225	—	—	—	—		
2300 [1085]	940	755	975	795	1015	830	1065	910	1100	965	1150	105	1180	1050	1225	1095	1265	1125	1310	1175	1350	1230	1375	1260	1405	1320	—	—	—	—		
2400 [1133]	970	825	1015	880	1040	925	1095	1005	1145	1055	1175	1085	1225	1140	1260	1175	1300	1210	1340	1255	1370	1315	1400	1375	—	—	—	—	—	—		
2500 [1179]	1015	910	1040	935	1095	1040	1145	1100	1170	1140	1200	1175	1260	1215	1305	1270	1360	1350	1400	1395	—	—	—	—	—	—	—	—	—	—	—	

NOTE: L-Drive left of bold line, M-Drive right of bold line.

Drive Package	L	M
Motor H.P. [W]	3/4 [559]	1 [746]
Blower Sheave	6.4" Pitch Diameter	6.4" Pitch Diameter
Motor Sheave	2.8"-3.8" Pitch Diameter—Adj.	3.4"-4.4" Pitch Diameter—Adj.
Turns Open	0 1 2 3 4	1 2 3 4 5 6
RPM	1095 1040 995 940 890 835 780	1405 1360 1305 1250 1195 1145 1095

NOTE: Factory sheave settings are shown in bold print.

[ ] Designates Metric Conversions



ELECTRICAL DATA – RKNA SERIES										
		-A036CK08E	-A036CK12E	-A036CL08E	-A036CL12E	-A036CM08E	-A036CM12E	-A036DK08E	-A036DK12E	-A036DL08E
Unit Information	Unit Operating Voltage Range	187-253	187-253	187-253	187-253	187-253	187-253	414-506	414-506	414-506
	Minimum Circuit Ampacity	18/18	18/18	17/17	17/17	17/17	17/17	11	11	10
	Minimum Overcurrent Protection Device Size	20/20	20/20	20/20	20/20	20/20	20/20	15	15	15
	Maximum Overcurrent Protection Device Size	25/25	25/25	25/25	25/25	25/25	25/25	15	15	15
Compressor Motor	No.	1	1	1	1	1	1	1	1	1
	Volts	208/230	208/230	208/230	208/230	208/230	208/230	460	460	460
	Phase	3	3	3	3	3	3	3	3	3
	HP	3	3	3	3	3	3	3	3	3
	RPM	3450	3450	3450	3450	3450	3450	3450	3450	3450
	Amps (RLA)	9.6/9.6	9.6/9.6	9.6/9.6	9.6/9.6	9.6/9.6	9.6/9.6	5.8	5.8	5.8
	Amps (LRA)	88/88	88/88	88/88	88/88	88/88	88/88	38	38	38
Condenser Motor	No.	1	1	1	1	1	1	1	1	1
	Volts	208/230	208/230	208/230	208/230	208/230	208/230	460	460	460
	Phase	1	1	1	1	1	1	1	1	1
	HP	1/3	1/3	1/3	1/3	1/3	1/3	1/3	1/3	1/3
	Amps (FLA)	1.5	1.5	1.5	1.5	1.5	1.5	1	1	1
	Amps (LRA)	3	3	3	3	3	3	1.9	1.9	1.9
Evaporator Fan	No.	1	1	1	1	1	1	1	1	1
	Volts	208/230	208/230	208/230	208/230	208/230	208/230	460	460	460
	Phase	1	1	3	3	3	3	1	1	3
	HP	1/2	1/2	1/2	1/2	1/2	1/2	1/2	1/2	1/2
	Amps (FLA)	4	4	2.8	2.8	2.8	2.8	2	2	1.4
	Amps (LRA)	6.7	6.7	11.3	11.3	11.3	11.3	3.6	3.6	6.2

1. Horsepower Per Compressor.
2. Amp Draw Per Motor. Multiply Value By Number of Motors to Determine Total Amps.



ELECTRICAL DATA – RKNA SERIES										
		-A036DL12E	-A036DM08E	-A036DM12E	-A036JK08E	-A036JK08X	-A036JK12E	-A036JK12X	-A042CK08E	-A042CK12E
Unit Information	Unit Operating Voltage Range	414-506	414-506	414-506	187-253	187-253	187-253	187-253	187-253	187-253
	Minimum Circuit Ampacity	10	10	10	24/24	24/24	24/24	24/24	21/21	21/21
	Minimum Overcurrent Protection Device Size	15	15	15	30/30	30/30	30/30	30/30	25/25	25/25
	Maximum Overcurrent Protection Device Size	15	15	15	35/35	35/35	35/35	35/35	30/30	30/30
Compressor Motor	No.	1	1	1	1	1	1	1	1	1
	Volts	460	460	460	208/230	208/230	208/230	208/230	208/230	208/230
	Phase	3	3	3	1	1	1	1	3	3
	HP	3	3	3	3	3	3	3	3 1/2	3 1/2
	RPM	3450	3450	3450	3450	3450	3450	3450	3450	3450
	Amps (RLA)	5.8	5.8	5.8	14.4/14.4	14.4/14.4	14.4/14.4	14.4/14.4	12.2/12.2	12.2/12.2
	Amps (LRA)	38	38	38	77/77	77/77	77/77	77/77	88/88	88/88
Condenser Motor	No.	1	1	1	1	1	1	1	1	1
	Volts	460	460	460	208/230	208/230	208/230	208/230	208/230	208/230
	Phase	1	1	1	1	1	1	1	1	1
	HP	1/3	1/3	1/3	1/3	1/3	1/3	1/3	1/3	1/3
	Amps (FLA)	1	1	1	1.5	1.5	1.5	1.5	1.5	1.5
	Amps (LRA)	1.9	1.9	1.9	3	3	3	3	3	3
Evaporator Fan	No.	1	1	1	1	1	1	1	1	1
	Volts	460	460	460	208/230	208/230	208/230	208/230	208/230	208/230
	Phase	3	3	3	1	1	1	1	1	1
	HP	1/2	1/2	1/2	1/2	1/2	1/2	1/2	1/2	1/2
	Amps (FLA)	1.4	1.4	1.4	4	4	4	4	4	4
	Amps (LRA)	6.2	6.2	6.2	6.7	6.7	6.7	6.7	6.7	6.7

1. Horsepower Per Compressor.
2. Amp Draw Per Motor. Multiply Value By Number of Motors to Determine Total Amps.



ELECTRICAL DATA – RKNA SERIES										
		-A042CL08E	-A042CL12E	-A042CM08E	-A042CM12E	-A042DK08E	-A042DK12E	-A042DL08E	-A042DL12E	-A042DM08E
Unit Information	Unit Operating Voltage Range	187-253	187-253	187-253	187-253	414-506	414-506	414-506	414-506	414-506
	Minimum Circuit Ampacity	20/20	20/20	20/20	20/20	11	11	10	10	10
	Minimum Overcurrent Protection Device Size	25/25	25/25	25/25	25/25	15	15	15	15	15
	Maximum Overcurrent Protection Device Size	30/30	30/30	30/30	30/30	15	15	15	15	15
Compressor Motor	No.	1	1	1	1	1	1	1	1	1
	Volts	208/230	208/230	208/230	208/230	460	460	460	460	460
	Phase	3	3	3	3	3	3	3	3	3
	HP	3 1/2	3 1/2	3 1/2	3 1/2	3 1/2	3 1/2	3 1/2	3 1/2	3 1/2
	RPM	3450	3450	3450	3450	3450	3450	3450	3450	3450
	Amps (RLA)	12.2/12.2	12.2/12.2	12.2/12.2	12.2/12.2	5.8	5.8	5.8	5.8	5.8
	Amps (LRA)	88/88	88/88	88/88	88/88	44	44	44	44	44
Condenser Motor	No.	1	1	1	1	1	1	1	1	1
	Volts	208/230	208/230	208/230	208/230	460	460	460	460	460
	Phase	1	1	1	1	1	1	1	1	1
	HP	1/3	1/3	1/3	1/3	1/3	1/3	1/3	1/3	1/3
	Amps (FLA)	1.5	1.5	1.5	1.5	1	1	1	1	1
	Amps (LRA)	3	3	3	3	1.9	1.9	1.9	1.9	1.9
Evaporator Fan	No.	1	1	1	1	1	1	1	1	1
	Volts	208/230	208/230	208/230	208/230	460	460	460	460	460
	Phase	3	3	3	3	1	1	3	3	3
	HP	1/2	1/2	1/2	1/2	1/2	1/2	1/2	1/2	1/2
	Amps (FLA)	2.8	2.8	2.8	2.8	2	2	1.4	1.4	1.4
	Amps (LRA)	11.3	11.3	11.3	11.3	3.6	3.6	6.2	6.2	6.2

1. Horsepower Per Compressor.
2. Amp Draw Per Motor. Multiply Value By Number of Motors to Determine Total Amps.



ELECTRICAL DATA – RKNA SERIES										
		-A042DM12E	-A042JK08E	-A042JK08X	-A042JK12E	-A042JK12X	-A048CK08E	-A048CK10E	-A048CK13E	-A048CL08E
Unit Information	Unit Operating Voltage Range	414-506	187-253	187-253	187-253	187-253	187-253	187-253	187-253	187-253
	Minimum Circuit Ampacity	10	30/30	30/30	30/30	30/30	21/21	21/21	21/21	20/20
	Minimum Overcurrent Protection Device Size	15	35/35	35/35	35/35	35/35	25/25	25/25	25/25	25/25
	Maximum Overcurrent Protection Device Size	15	45/45	45/45	45/45	45/45	30/30	30/30	30/30	30/30
Compressor Motor	No.	1	1	1	1	1	1	1	1	1
	Volts	460	208/230	208/230	208/230	208/230	208/230	208/230	208/230	208/230
	Phase	3	1	1	1	1	3	3	3	3
	HP	3 1/2	3 1/2	3 1/2	3 1/2	3 1/3	4	4	4	4
	RPM	3450	3450	3450	3450	3450	3450	3450	3450	3450
	Amps (RLA)	5.8	19.2/19.2	19.2/19.2	19.2/19.2	19.2/19.2	12.2/12.2	12.2/12.2	12.2/12.2	12.2/12.2
	Amps (LRA)	44	104/104	104/104	104/104	104/104	80.8/80.8	80.8/80.8	80.8/80.8	80.8/80.8
Condenser Motor	No.	1	1	1	1	1	1	1	1	1
	Volts	460	208/230	208/230	208/230	208/230	208/230	208/230	208/230	208/230
	Phase	1	1	1	1	1	1	1	1	1
	HP	1/3	1/3	1/3	1/3	1/3	1/3	1/3	1/3	1/3
	Amps (FLA)	1	1.5	1.5	1.5	1.5	1.5	1.5	1.5	1.5
	Amps (LRA)	1.9	3	3	3	3	3	3	3	3
Evaporator Fan	No.	1	1	1	1	1	1	1	1	1
	Volts	460	208/230	208/230	208/230	208/230	208/230	208/230	208/230	208/230
	Phase	3	1	1	1	1	1	1	1	3
	HP	1/2	1/2	1/2	1/2	1/2	1/2	1/2	1/2	1/2
	Amps (FLA)	1.4	4	4	4	4	4	4	4	2.8
	Amps (LRA)	6.2	6.7	6.7	6.7	6.7	6.7	6.7	6.7	11.3

1. Horsepower Per Compressor.

2. Amp Draw Per Motor. Multiply Value By Number of Motors to Determine Total Amps.



<b>ELECTRICAL DATA – RKNA SERIES</b>										
		<b>-A048CL10E</b>	<b>-A048CL13E</b>	<b>-A048CM08E</b>	<b>-A048CM10E</b>	<b>-A048CM13E</b>	<b>-A048DK08E</b>	<b>-A048DK10E</b>	<b>-A048DK13E</b>	<b>-A048DL08E</b>
<b>Unit Information</b>	Unit Operating Voltage Range	187-253	187-253	187-253	187-253	187-253	414-506	414-506	414-506	414-506
	Minimum Circuit Ampacity	20/20	20/20	21/21	21/21	21/21	11	11	11	11
	Minimum Overcurrent Protection Device Size	25/25	25/25	25/25	25/25	25/25	15	15	15	15
	Maximum Overcurrent Protection Device Size	30/30	30/30	30/30	30/30	30/30	15	15	15	15
<b>Compressor Motor</b>	No.	1	1	1	1	1	1	1	1	1
	Volts	208/230	208/230	208/230	208/230	208/230	460	460	460	460
	Phase	3	3	3	3	3	3	3	3	3
	HP	4	4	4	4	4	4	4	4	4
	RPM	3450	3450	3450	3450	3450	3450	3450	3450	3450
	Amps (RLA)	12.2/12.2	12.2/12.2	12.2/12.2	12.2/12.2	12.2/12.2	6.1	6.1	6.1	6.1
	Amps (LRA)	80.8/80.8	80.8/80.8	80.8/80.8	80.8/80.8	80.8/80.8	41	41	41	41
<b>Condenser Motor</b>	No.	1	1	1	1	1	1	1	1	1
	Volts	208/230	208/230	208/230	208/230	208/230	460	460	460	460
	Phase	1	1	1	1	1	1	1	1	1
	HP	1/3	1/3	1/3	1/3	1/3	1/3	1/3	1/3	1/3
	Amps (FLA)	1.5	1.5	1.5	1.5	1.5	1	1	1	1
	Amps (LRA)	3	3	3	3	3	1.9	1.9	1.9	1.9
<b>Evaporator Fan</b>	No.	1	1	1	1	1	1	1	1	1
	Volts	208/230	208/230	208/230	208/230	208/230	460	460	460	460
	Phase	3	3	3	3	3	1	1	1	3
	HP	1/2	1/2	3/4	3/4	3/4	1/2	1/2	1/2	1/2
	Amps (FLA)	2.8	2.8	3.4	3.4	3.4	2	2	2	1.4
	Amps (LRA)	11.3	11.3	16.8	16.8	16.8	3.6	3.6	3.6	6.2

1. Horsepower Per Compressor.
2. Amp Draw Per Motor. Multiply Value By Number of Motors to Determine Total Amps.



ELECTRICAL DATA – RKNA SERIES										
		-A048DL10E	-A048DL13E	-A048DM08E	-A048DM10E	-A048DM13E	-A048JK08E	-A048JK08X	-A048JK10E	-A048JK10X
Unit Information	Unit Operating Voltage Range	414-506	414-506	414-506	414-506	414-506	187-253	187-253	187-253	187-253
	Minimum Circuit Ampacity	11	11	11	11	11	31/31	31/31	31/31	31/31
	Minimum Overcurrent Protection Device Size	15	15	15	15	15	40/40	40/40	40/40	40/40
	Maximum Overcurrent Protection Device Size	15	15	15	15	15	50/50	50/50	50/50	50/50
Compressor Motor	No.	1	1	1	1	1	1	1	1	1
	Volts	460	460	460	460	460	208/230	208/230	208/230	208/230
	Phase	3	3	3	3	3	1	1	1	1
	HP	4	4	4	4	4	4	4	4	4
	RPM	3450	3450	3450	3450	3450	3450	3450	3450	3450
	Amps (RLA)	6.1	6.1	6.1	6.1	6.1	20.2/20.2	20.2/20.2	20.2/20.2	20.2/20.2
	Amps (LRA)	41	41	41	41	41	137/137	137/137	137/137	137/137
Condenser Motor	No.	1	1	1	1	1	1	1	1	1
	Volts	460	460	460	460	460	208/230	208/230	208/230	208/230
	Phase	1	1	1	1	1	1	1	1	1
	HP	1/3	1/3	1/3	1/3	1/3	1/3	1/3	1/3	1/3
	Amps (FLA)	1	1	1	1	1	1.5	1.5	1.5	1.5
	Amps (LRA)	1.9	1.9	1.9	1.9	1.9	3	3	3	3
Evaporator Fan	No.	1	1	1	1	1	1	1	1	1
	Volts	460	460	460	460	460	208/230	208/230	208/230	208/230
	Phase	3	3	3	3	3	1	1	1	1
	HP	1/2	1/2	3/4	3/4	3/4	1/2	1/2	1/2	1/2
	Amps (FLA)	1.4	1.4	1.6	1.6	1.6	4	4	4	4
	Amps (LRA)	6.2	6.2	8.4	8.4	8.4	6.7	6.7	6.7	6.7

1. Horsepower Per Compressor.
2. Amp Draw Per Motor. Multiply Value By Number of Motors to Determine Total Amps.



ELECTRICAL DATA – RKNA SERIES										
		-A048JK13E	-A048JK13X	-A060CK10E	-A060CK13E	-A060CL10E	-A060CL13E	-A060CM10E	-A060CM13E	-A060DL10E
Unit Information	Unit Operating Voltage Range	187-253	187-253	187-253	187-253	187-253	187-253	187-253	187-253	414-506
	Minimum Circuit Ampacity	31/31	31/31	30/30	30/30	25/25	25/25	26/26	26/26	12
	Minimum Overcurrent Protection Device Size	40/40	40/40	35/35	35/35	30/30	30/30	30/30	30/30	15
	Maximum Overcurrent Protection Device Size	50/50	50/50	40/40	40/40	40/40	40/40	40/40	40/40	15
Compressor Motor	No.	1	1	1	1	1	1	1	1	1
	Volts	208/230	208/230	208/230	208/230	208/230	208/230	208/230	208/230	460
	Phase	1	1	3	3	3	3	3	3	3
	HP	4	4	5	5	5	5	5	5	5
	RPM	3450	3450	3450	3450	3450	3450	3450	3450	3450
	Amps (RLA)	20.2/20.2	20.2/20.2	15.4/15.4	15.4/15.4	15.4/15.4	15.4/15.4	15.4/15.4	15.4/15.4	7.1
	Amps (LRA)	137/137	137/137	110/110	110/110	110/110	110/110	110/110	110/110	52
Condenser Motor	No.	1	1	1	1	1	1	1	1	1
	Volts	208/230	208/230	208/230	208/230	208/230	208/230	208/230	208/230	460
	Phase	1	1	1	1	1	1	1	1	1
	HP	1/3	1/3	1/3	1/3	1/3	1/3	1/3	1/3	1/3
	Amps (FLA)	1.5	1.5	2.2	2.2	2.2	2.2	2.2	2.2	1
	Amps (LRA)	3	3	4.9	4.9	4.9	4.9	4.9	4.9	1.9
Evaporator Fan	No.	1	1	1	1	1	1	1	1	1
	Volts	208/230	208/230	208/230	208/230	208/230	208/230	208/230	208/230	460
	Phase	1	1	1	1	3	3	3	3	3
	HP	1/2	1/2	1	1	3/4	3/4	1	1	3/4
	Amps (FLA)	4	4	7.6	7.6	3.4	3.4	3.8	3.8	1.6
	Amps (LRA)	6.7	6.7	0	0	16.8	16.8	24	24	8.4

1. Horsepower Per Compressor.
2. Amp Draw Per Motor. Multiply Value By Number of Motors to Determine Total Amps.



ELECTRICAL DATA – RKNA SERIES								
		-A060DL13E	-A060DM10E	-A060DM13E	-A060JK10E	-A060JK10X	-A060JK13E	-A060JK13X
Unit Information	Unit Operating Voltage Range	414-506	414-506	414-506	187-253	187-253	187-253	187-253
	Minimum Circuit Ampacity	12	12	12	42/42	42/42	42/42	42/42
	Minimum Overcurrent Protection Device Size	15	15	15	50/50	50/50	50/50	50/50
	Maximum Overcurrent Protection Device Size	15	15	15	60/60	60/60	60/60	60/60
Compressor Motor	No.	1	1	1	1	1	1	1
	Volts	460	460	460	208/230	208/230	208/230	208/230
	Phase	3	3	3	1	1	1	1
	HP	5	5	5	5	5	5	5
	RPM	3450	3450	3450	3450	3450	3450	3450
	Amps (FLA)	7.1	7.1	7.1	25.3/25.3	25.3/25.3	25.3/25.3	25.3/25.3
	Amps (LRA)	52	52	52	141/141	141/141	141/141	141/141
Condenser Motor	No.	1	1	1	1	1	1	1
	Volts	460	460	460	208/230	208/230	208/230	208/230
	Phase	1	1	1	1	1	1	1
	HP	1/3	1/3	1/3	1/3	1/3	1/3	1/3
	Amps (FLA)	1	1	1	2.2	2.2	2.2	2.2
	Amps (LRA)	1.9	1.9	1.9	4.9	4.9	4.9	4.9
Evaporator Fan	No.	1	1	1	1	1	1	1
	Volts	460	460	460	208/230	208/230	208/230	208/230
	Phase	3	3	3	1	1	1	1
	HP	3/4	1	1	1	1	1	1
	Amps (FLA)	1.6	1.9	1.9	7.6	7.6	7.6	7.6
	Amps (LRA)	8.4	12	12	0	0	0	0

1. Horsepower Per Compressor.
2. Amp Draw Per Motor. Multiply Value By Number of Motors to Determine Total Amps.



## UNIT DIMENSIONS PACKAGE GAS ELECTRIC UNITS

## RKNA 3 TO 5 TON [10.6 TO 17.6 kW] MODELS

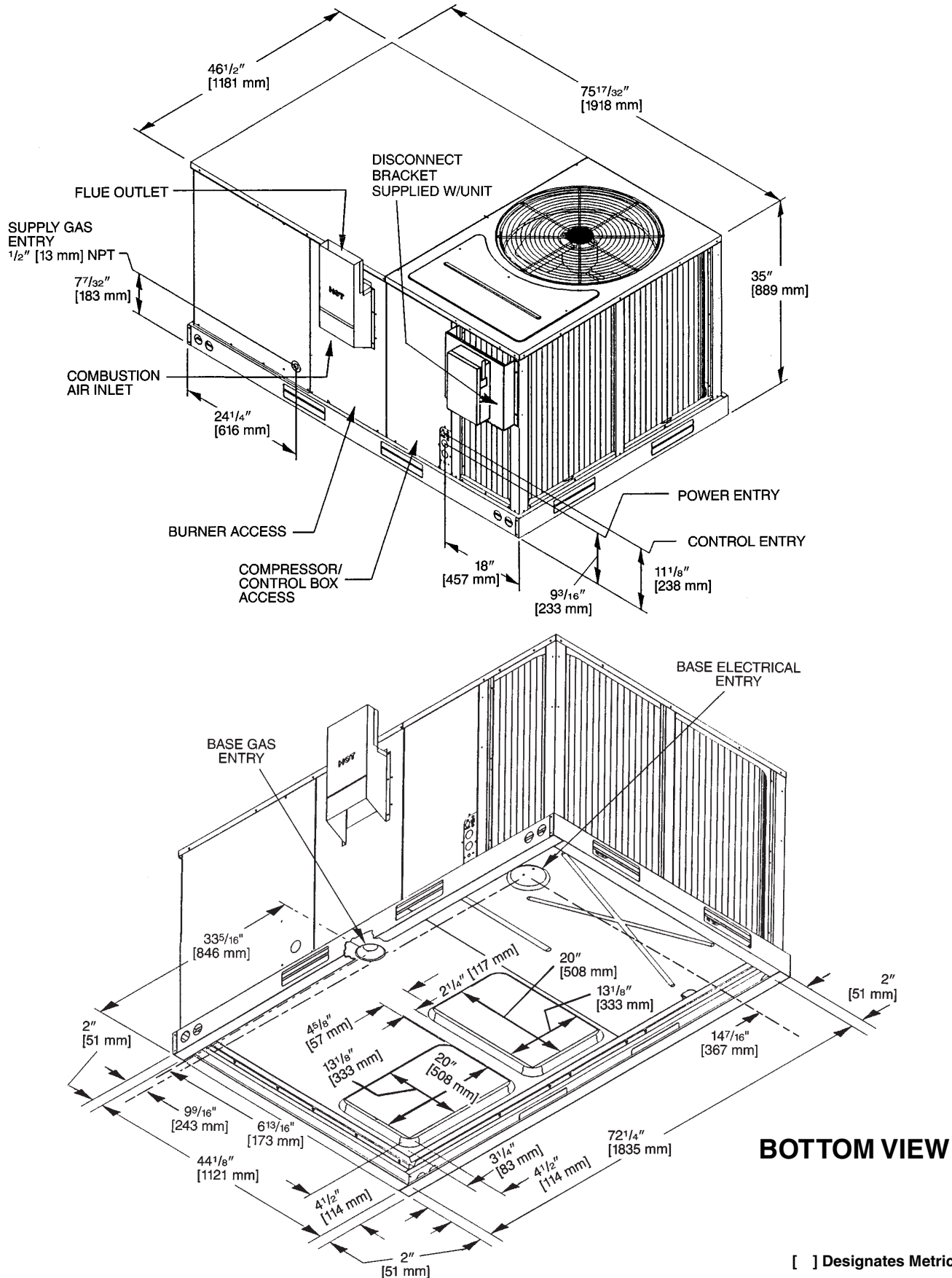

[ ] Designates Metric Conversions

## UNIT DIMENSIONS PACKAGE GAS ELECTRIC UNITS

## RKNA 3 TO 5 TON [10.6 TO 17.6 kW] MODELS

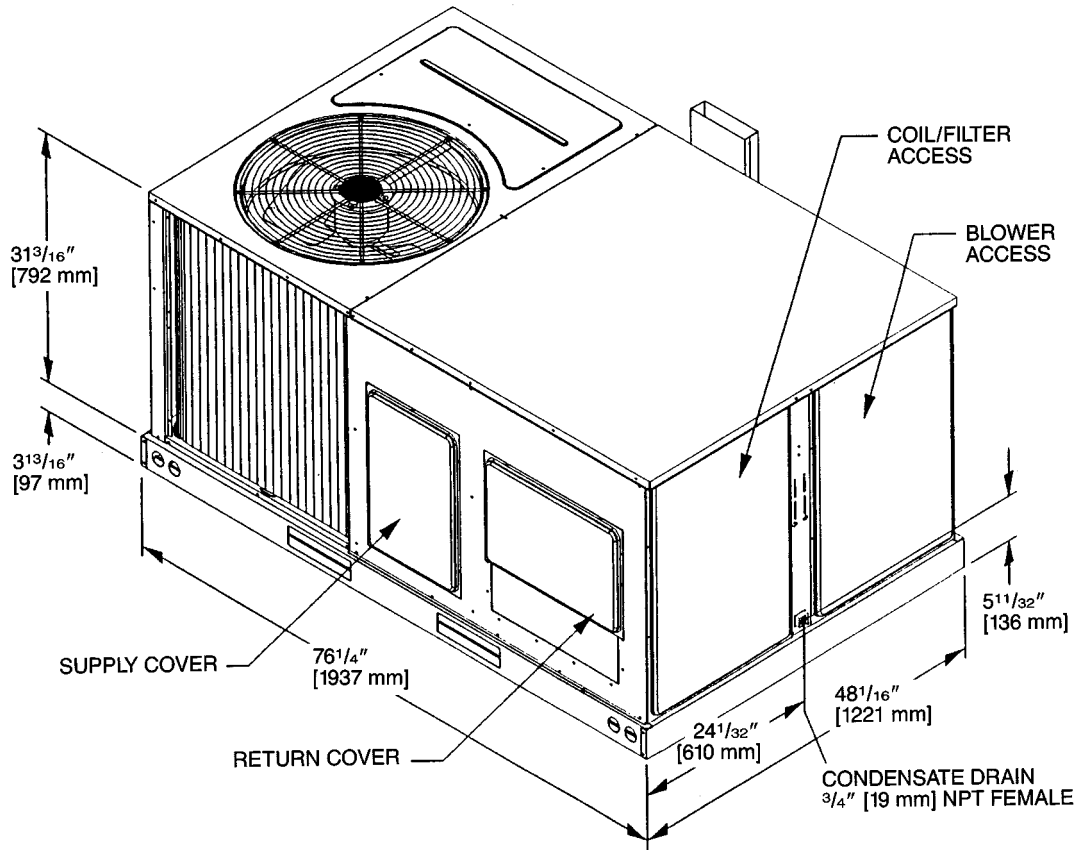

### SUPPLY AND RETURN DIMENSIONS

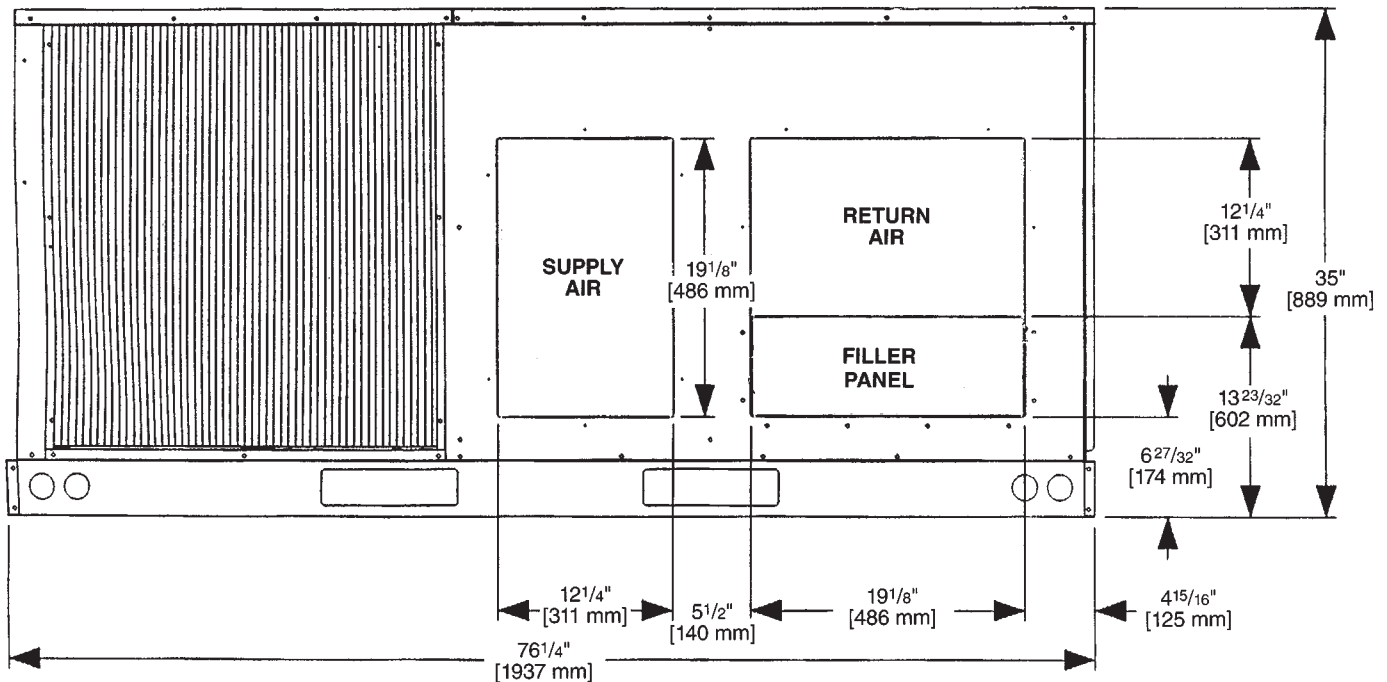

[ ] Designates Metric Conversions



## WEIGHTS

Accessory	3-5 Ton [10.6-17.6 kW]	
	Shipping	Operating
	lbs [kg]	lbs [kg]
Economizer with Single Enthalpy	70 [32]	60 [27]
Power Exhaust	19 [9]	16 [7]
Fresh Air Damper (Manual)	11 [5]	9 [4]
Fresh Air Damper (Motorized)	13 [6]	11 [5]
Roof Curb 14"	92 [42]	88 [40]
Roof Curb 24"	108 [49]	104 [47]
Concentric Diffuser 18" Flush	37 [17]	26 [12]
Concentric Diffuser 20" Flush	54 [24]	42 [19]
Side Discharge Concentric Diffuser RXRN-FA60	35 [16]	20 [9]
Side Discharge Concentric Diffuser RXRN-FA65	55 [25]	40 [18]

### CENTER OF GRAVITY (C.G.)

Capacity Tons [kW]	A in. [mm]	B in. [mm]
3-5 [10.6-17.6]	38 <sup>1</sup> / <sub>4</sub> [972]	25 <sup>3</sup> / <sub>4</sub> [654]

Capacity Tons [kW]	Corner Weights by Percentage			
	A	B	C	D
3-5 [10.6-17.6]	22%	27%	23%	28%

## CLEARANCES

### (3 to 5 Ton [10.6 to 17.6 kW] Models)

The following minimum clearances are recommended for proper unit performance and serviceability.

Recommended Clearance in. [mm]	Location
48 [1219]	A - Front
18 [457]	B - Condenser Coil
12 [305]	C - Duct Side
36 [914]	D - Evaporator End
60 [1524]	E - Above

\*Without Economizer. 57" [1448 mm] With Economizer

**NOTE:** Supply duct may be installed with "0" inch clearance to combustible materials, provided 1" [25.4 mm] minimum Fiberglass insulation is applied either inside or on the outside of the duct.

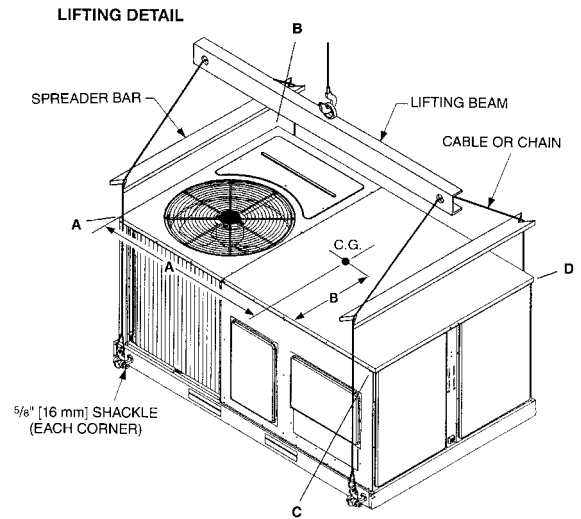
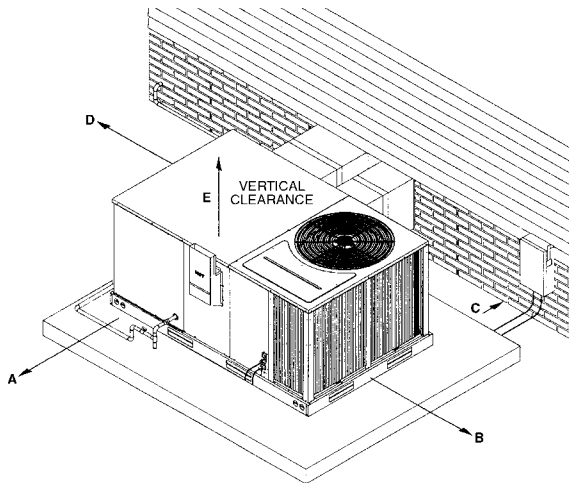

[ ] Designates Metric Conversions

## ACCESSORY EQUIPMENT

Accessory Description	Model Application 3 to 5 Ton [10.6 to 17.6 kW]	Accessory Model No. 3 to 5 Ton [10.6 to 17.6 kW]	Factory Installed 3 to 5 Ton [10.6 to 17.6 kW]
Thermostats	RKNA-	See Thermostat Specification Sheet (T11-001)	No
Roofcurb 14"	RKNA-	RXKG-CAD14	No
Roofcurb 24"	RKNA-	RXKG-CAD24	No
Roofcurb Adapters	RKNA-	RXR-BCDB21 RXR-BCDB22 RXR-BCDB23	No
Economizer with Single Enthalpy ②	RKNA-	RXR-MECM3	Yes
Dual Enthalpy Kit	RKNA-	RXR-AV02	No
CO <sub>2</sub> Sensor Only	RKNA-	RXR-AR02	No
Power Exhaust	RKNA-	RXR-BGF04 (C, D & Y)	No
Fresh Air Damper Manual	RKNA-	RXR-FBA1	No
Fresh Air Damper Motorized	RKNA-	RXR-FBB1	No
Rectangular to Round 18" Duct Adapters for Concentric Diffuser	RKNA-	RXMC-CB03	No
Rectangular to Round 20" Duct Adapters for Concentric Diffuser	RKNA-	RXMC-CB04	No
Concentric Diffuser 18" Step	RKNA-	RXR-FA60	No
Concentric Diffuser 18" Flush	RKNA-	RXR-FA70	No
Rectangular to Round 16" Side	RKNA-	RXMC-BB01	No
Louver Kit (3 Sides)	All RKNA- Models	RXR-AAD01B	Yes
Time Delay	RKNA-	RXMD-B01	Yes
High Pressure	RKNA-	RXAB-A02	Yes
Low Pressure	RKNA-	RXAC-A02	Yes
Low Ambient Control to 0°F [-18°C]	RKNA-	RXRZ-A18	Yes
LP Conversion Kits for use with White Rodgers Gas Valve ①	RKNA-	RXGJ-EP84W	No
LP Conversion Kits for use with Honeywell Gas Valve ①	RKNA-	RXGJ-EP85H	No
Canadian High Altitude Kit (for Natural Gas Only) ①	RKNA-	RXR-AH01	No

\*Voltage J = 208/230 VAC-1PH-60HZ D = 460 VAC-3PH-60HZ  
C = 208/230 VAC-3PH-60HZ

**NOTES:** ① If a particular unit is to be converted to operate on **LP (propane)** for elevations above 2000 ft. in Canada, the existing Natural Gas to LP Conversion Kits for the subject models already contain the necessary orifices and instructions to de-rate the input for 2000-4500 ft. Canadian applications.

② Economizer is designed for downflow or horizontal applications.

[ ] Designates Metric Conversions

## THERMOSTATS



**300-Series \***  
Deluxe Programmable

**200-Series \***  
Programmable

**100-Series \***  
Non-Programmable

**400-Series \***  
Special Applications/Programmable

Brand	Unique Model Number Prefix	Descriptor (3 Characters)	Series (3 Characters)	System (2 Characters)	Type (2 Characters)
RHC	-	TST	101	GE	MS
RHC=Rheem		TST=Thermostat	100=Non-Programmable 200=Programmable 300=Deluxe Programmable 400=Special Applications/Programmable	GE=Gas/Oil/Electric HP=Heat Pump MD=Modulating Furnace DF=Dual Fuel UN=Universal AC/HP/GE	SS=Single-Stage MS=Multi-Stage

\* Photos are representative. Actual models may vary.

For detailed thermostat match-up information, see specification sheet form number T11-001.

## Roofcurb Adapters

### Old Models

#### MEDIUM CABINET (3 TON [11 kW])

(-)SNC, (-)SND, (-)SNE  
(-)RGE, (-)RGF, (-)RGG  
(-)PNC, (-)PND

#### LARGE CABINET (3-3 1/2 TON [11-12 kW])

(-)RGE, (-)RGF, (-)RGG,  
(-)RGH (3 TON [11 kW])

#### EXTRA LARGE CABINET (3 1/2-5 TON [12-18 kW])

(-)SNC, (-)SND, (-)SNE  
(-)RGE, (-)RGF,  
(-)RGG (4-5 TON [14-18 kW])  
(-)PNC, (-)PND, (-)RGH  
(3 1/2, 4 TON [12-14 kW])

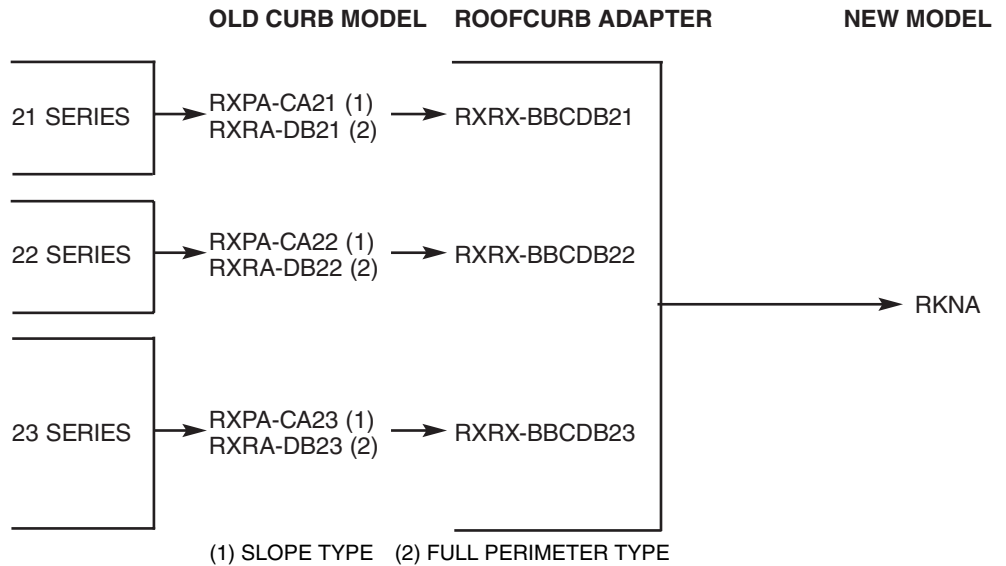

[ ] Designates Metric Conversions

## ROOFCURBS (Full Perimeter)

- Rheem's new roofcurb design can be utilized on 3 through 5 ton [10.6-17.6 kW] models.
- Two available heights (14" [356 mm] and 24" [610 mm]) for ALL models.
- Quick assembly corners for simple and fast assembly.
- Opening provided in bottom pan to match the "Thru the Curb" electrical connection opening provided on the unit base pan.
- 2" [51 mm] x 4" [102 mm] Nailers provided.
- Insulating panels provided.
- Sealing gasket (28" [711 mm]) provided with Roofcurb.
- Packaged for easy field assembly.

Roofcurb Model	Height of Curb
RXKG-CAD14	14" [356 mm]
RXKG-CAD24	24" [610 mm]

[ ] Designates Metric Conversions

## TYPICAL INSTALLATION

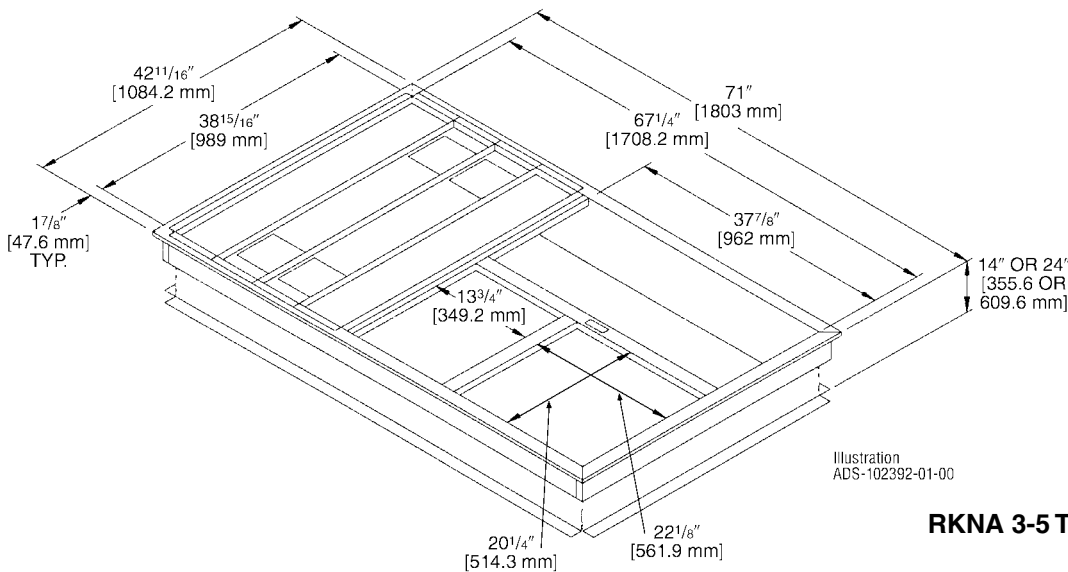
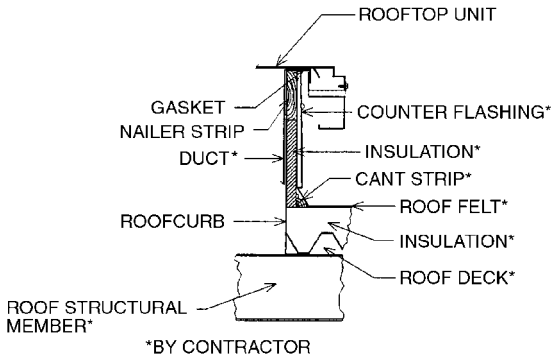
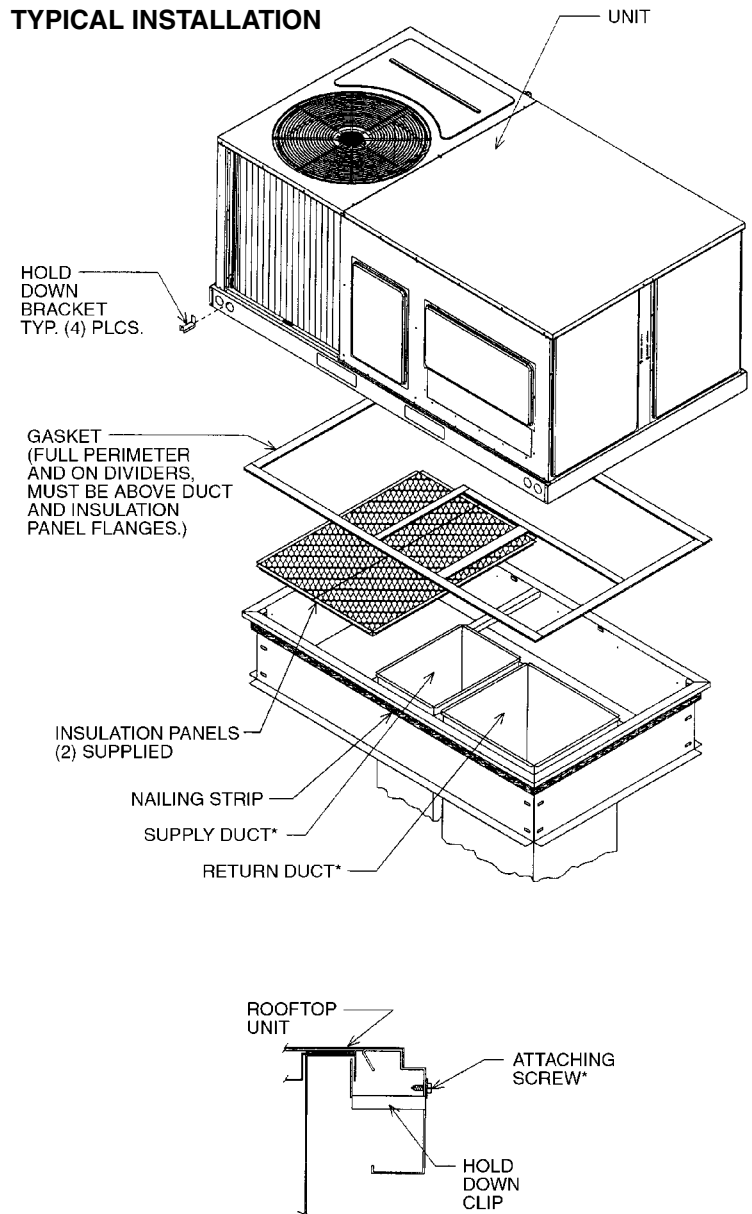

Illustration  
ADS-102392-01-00

**ROOFCURB FOR  
RKNA 3-5 TON [10.6-17.6 kW] MODELS**

## ECONOMIZERS

RXRD-MECM3—RKNA 3-5 Ton [10.6-17.6 kW] Models

RXXR-AV02—3-5 Ton [10.6-17.6 kW] Models

RXXR-AR02—3-5 Ton [10.6-17.6 kW] Models

Single Enthalpy (with Barometric Relief)

Dual Enthalpy Kit

Optional CO<sub>2</sub> Sensor

- Features **Honeywell** Analog Controls
- Available factory installed or field accessory
- Gear Driven Direct Drive Actuator
- Fully Modulating (0-100%)
- Low Leakage Dampers
- Horizontal or Downflow Applications
- Slip-In Design for Easy Installations
- Plug-In Polarized 9-pin Electrical Connections
- Pre-configuring—No Field Adjustments Necessary
- Standard Barometric Relief Damper Provided
- Single Enthalpy with Dual Enthalpy upgrade kit
- CO<sub>2</sub> Input Sensor Available (field installed)
- Economizer slips in complete for downflow or horizontal duct applications
- Field assembled hood ships with Economizer
- Optional Remote minimum position (Honeywell #S963B1128) is available from ProStock.
- Field installed power exhaust available.

[ ] Designates Metric Conversions

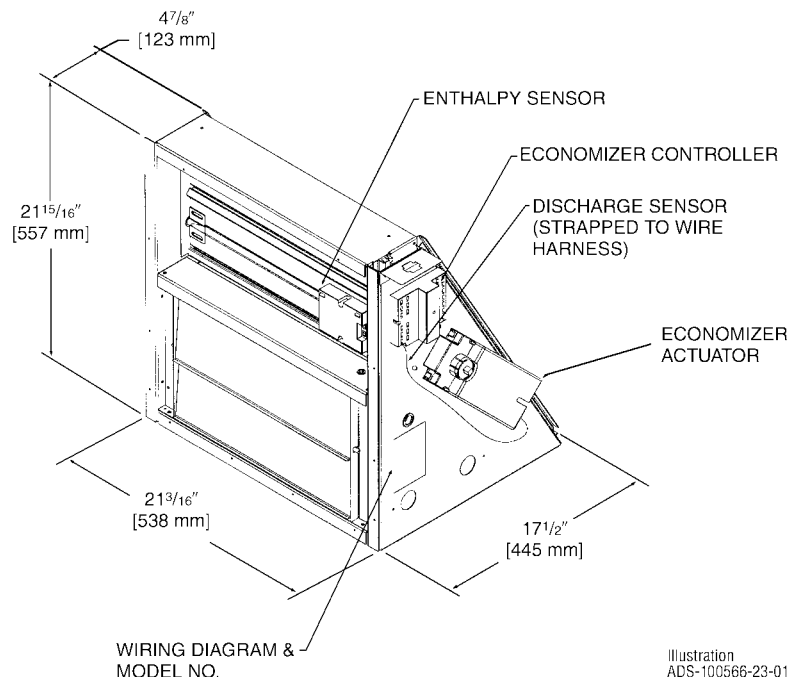
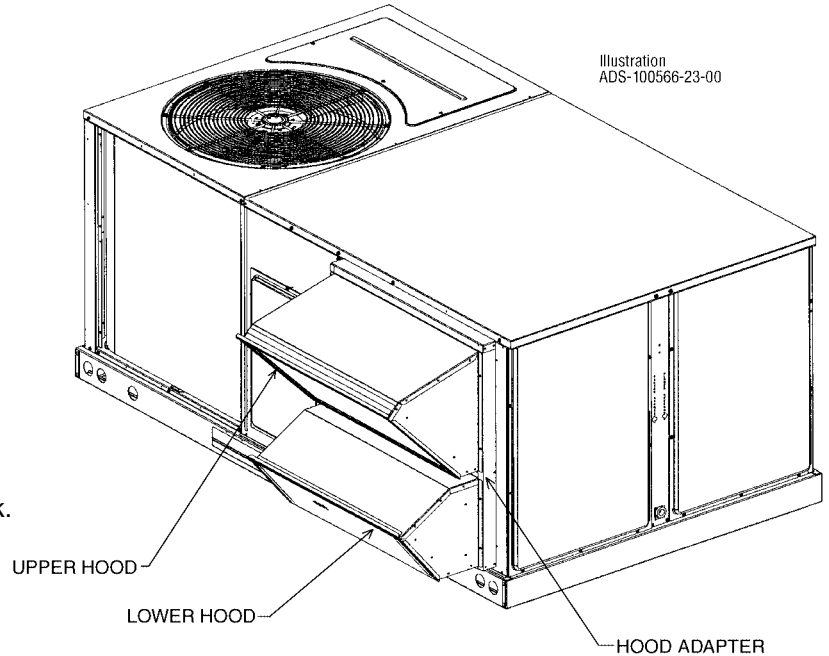

RKNA 3-5 Ton [10.6-17.6 kW] Models

## INTEGRAL POWER EXHAUST FOR ECONOMIZER (FIELD INSTALLED ONLY)

**RXRX-BGF04C**—RKNA 3-5 Ton [10.6-17.6 kW] Models  
208-230V, 1 PH and 3 PH, 60 Hz

**RXRX-BGF04D**—RKNA 3-5 Ton [10.6-17.6 kW] Models  
460V, 3 PH, 60 Hz

**RXRX-BGF04Y**—RKNA 3-5 Ton [10.6-17.6 kW] Models  
575V, 3 PH, 60 Hz

- For **Honeywell** economizer.
- Downflow or horizontal applications.
- Requires separate 208-230 Volt – 1 PH power supply with disconnect or requires separate 460V – 3 PH power supply with disconnect.
- Adjustable switch on economizer, factory preset to energize power exhaust at 95% outside air position.
- Polarized plug connects power exhaust relay to economizer.

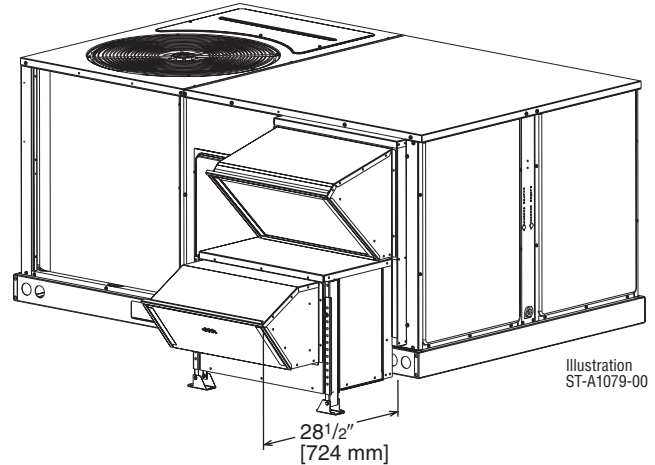

## POWER EXHAUST KIT FOR RXRD-MCCM(-), RXRD-MECM(-) ECONOMIZERS

Model No.	No. of Fans	Volts	Phase	Watts (ea.)	High Speed		FLA (ea.)	LRA (ea.)
					CFM ①	RPM		
RXRX-BGF04C	1	208/230	1	1000	2500	1725	4.4	23.7
RXRX-BGF04D	1	460	1	800	2370	1620	1.8	4.1
RXRX-BGF04Y	1	575	1	800	2370	1620	1.5	3.3

① CFM is at 0" W.C. external static pressure.

## FRESH AIR DAMPER

**RKNA 3-5 Ton [10.6-17.6 kW] Models**

RXRF-FBA1 (Manual)

RXRF-FBB1 (Motorized)

Shipping lbs [kg]	Operating lbs [kg]
70 [32]	67 [30]

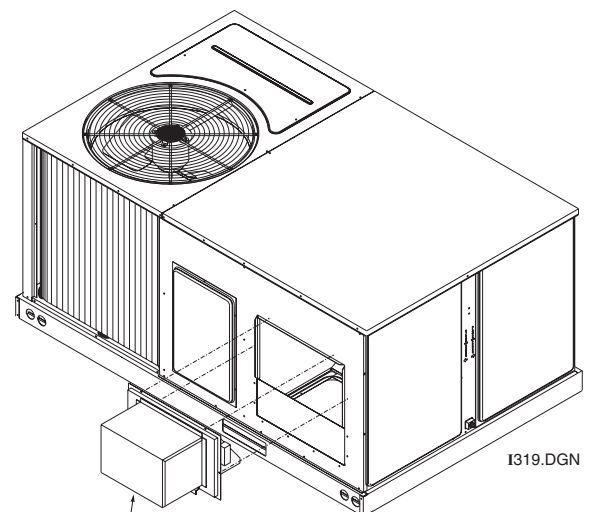

[ ] Designates Metric Conversions

## DUCT ADAPTERS (RKNA 3-5 Ton [10.6-17.6 kW] Models) Rectangular to Round Transitions (Downflow)

RXMC-CB03 sizes available  
18" [457 mm] fit all units.  
Drops into and secures to  
RXKG- Series Roofcurbs.

**For use with  
Concentric Diffusers.**

[ ] Designates Metric Conversions

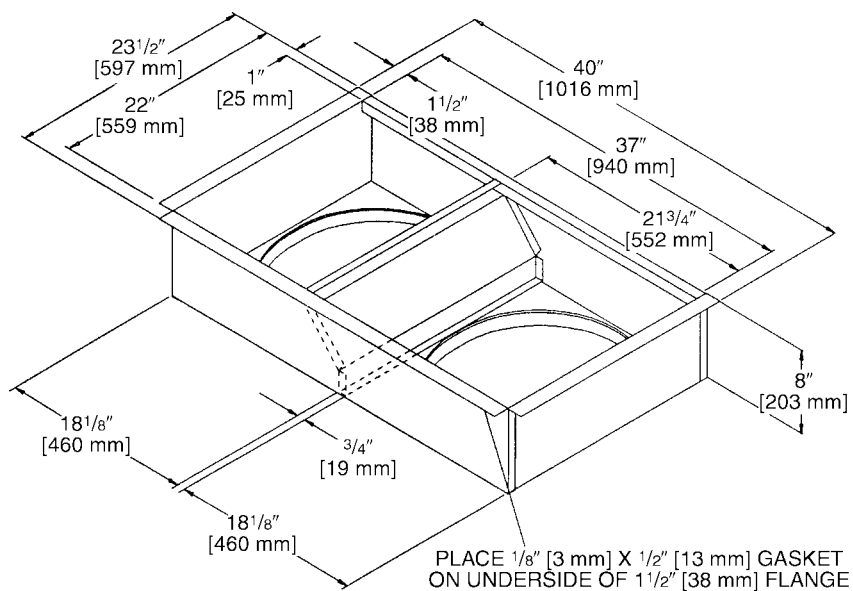

## SIDE DISCHARGE CONCENTRIC DIFFUSER

RXRN-FA60 (3 to 6 Ton [10.6 to 21.1 kW] Models)  
 RXRN-FA65 (3 to 7.5 Ton [10.6 to 26.4 kW] Models)

For Use With Duct Adapter (RXMC)

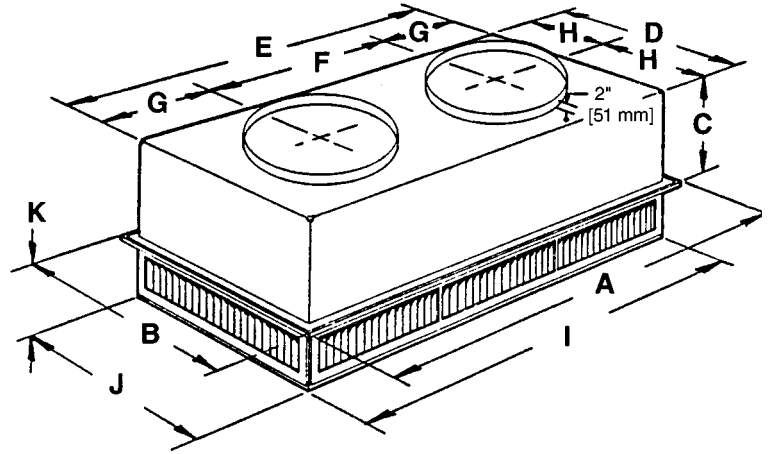

### DIMENSIONAL DATA

Model No.	A	B	C	D	E	F	G	H	I	J	K	Duct Size
RXRN-FA60	47 <sup>5</sup> / <sub>8</sub> " [1210 mm]	23 <sup>5</sup> / <sub>8</sub> " [600 mm]	11 <sup>3</sup> / <sub>8</sub> " [289 mm]	21 <sup>1</sup> / <sub>2</sub> " [546 mm]	45 <sup>1</sup> / <sub>2</sub> " [1156 mm]	22 <sup>1</sup> / <sub>2</sub> " [572 mm]	11 <sup>1</sup> / <sub>2</sub> " [292 mm]	10 <sup>3</sup> / <sub>4</sub> " [273 mm]	45 <sup>1</sup> / <sub>2</sub> " [1156 mm]	21 <sup>1</sup> / <sub>2</sub> " [546 mm]	7 <sup>1</sup> / <sub>8</sub> " [181 mm]	18RD

### ENGINEERING DATA

Model No.	CFM [L/s]	Static Pressure	Throw Feet	Neck Vel.	Jet Vel.	Noise Level
RXRN-FA60	1000 [472]	.14	10-17	351	351	20
	1200 [566]	.17	11-18	421	421	20
	1400 [661]	.20	12-19	491	491	20
	1600 [755]	.24	12-20	561	561	20
	1800 [850]	.30	13-21	632	632	20
	2000 [944]	.36	14-23	702	702	20
	2200 [1038]	.40	16-25	772	772	20

[ ] Designates Metric Conversions

## FLUSH MOUNT CONCENTRIC DIFFUSER

RXRN-FA70 (3 to 6 Ton [10.6 to 21.1 kW] Models)  
 RXRN-FA75 (3 to 7.5 Ton [10.6 to 26.4 kW] Models)

For Use With Duct Adapter (RXMC)

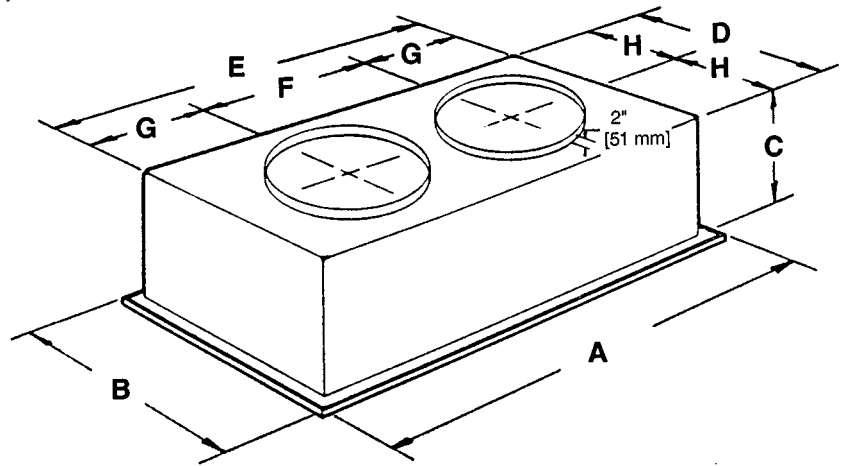

### DIMENSIONAL DATA

Model No.	A	B	C	D	E	F	G	H	Duct Size
RXRN-FA70	47 <sup>5</sup> / <sub>8</sub> " [1210 mm]	23 <sup>5</sup> / <sub>8</sub> " [600 mm]	13 <sup>1</sup> / <sub>2</sub> " [343 mm]	21" [533 mm]	45" [1143 mm]	22 <sup>1</sup> / <sub>2</sub> " [572 mm]	11 <sup>1</sup> / <sub>4</sub> " [286 mm]	10 <sup>1</sup> / <sub>2</sub> " [267 mm]	18RD

### ENGINEERING DATA

Model No.	CFM [L/s]	Static Pressure	Throw Feet	Neck Vel.	Jet Vel.	Noise Level
RXRN-FA70	1000 [472]	.14	15-20	391	694	20
	1200 [566]	.17	16-22	469	833	25
	1400 [661]	.20	17-24	547	972	30
	1600 [755]	.24	18-25	625	1111	30
	1800 [850]	.30	20-28	703	1250	35
	2000 [944]	.36	21-29	781	1389	40
	2200 [1038]	.40	22-30	859	1528	40

[ ] Designates Metric Conversions

## SAMPLE SPECIFICATIONS

Unit shall be completely factory assembled and performance tested to provide the required cooling and heating functions suitable for outdoor installations. Unit shall be UL/cUL listed and rated in accordance to ARI Standard 210.

### CABINET

Unit casing, base pan and framework shall be manufactured of galvanized sheet metal primed and finished with powder paint capable of withstanding a 1000-hour salt spray test per ASTM B 117. Unit interior cabinet surfaces shall be insulated with a minimum 1/2-inch thick foil faced insulation. Access panels shall be easily removable providing access to the blower, filter, heating compartment, and compressor/control box. Unit base rails shall be provided with fork insertion slots and rigging holes. Condensate drain pan shall be of sloped design to conform to ASHRAE 62. Unit shall be supplied ready for vertical airflow and be easily convertible to horizontal airflow at or before installation.

### COMPRESSOR(S)

Unit shall be provided with fully hermetic scroll compressor(s) with internally protected safety controls.

### COILS

The evaporator and condenser coils shall be fabricated of copper tubes with mechanically bonded aluminum plate fins. They shall be pressure tested prior to assembly into the unit, and electronically leak tested after assembly.

### CONDENSER FAN

A single direct drive propeller fan shall discharge air vertically upward. The fan motor shall be permanently lubricated and have built-in overload protection.

### EVAPORATOR BLOWER

A single, double inlet, centrifugal wheel shall rotate in permanently lubricated ball bearings. The wheel shall be made from steel with corrosion resistant finish and shall be statically and dynamically balanced.

### HEATING SECTION

Heat exchanger shall be of the tubular type made of aluminized steel. Burners shall be of the in-shot type. Unit shall be equipped with an integrated direct spark ignition control board with built-in diagnostics feature. Safeties to include limit, lockout, and flame roll-out switches.

## ACCESSORIES

### ROOF CURB

Curb shall be full perimeter type, complying with the standards of the National Roofing Contractors Association. Design shall provide for drop-in of supply and return ducts prior to setting unit, and include an insulating panel for the rest of the curb area.

### ECONOMIZER

Economizer shall be completely assembled for field installation. Unit shall include all controls and dampers including the barometric relief damper. Shall be offered for both vertical and horizontal applications.

### MANUAL FRESH AIR DAMPER

Damper shall consist of damper and rainhood which is manually preset to admit up to 35% of outside air for field installation.

### MOTORIZED FRESH AIR DAMPER

Damper shall consist of motor, damper, and rainhood which can admit up to 35% of outside air for field installation.

### PRESSURE CONTROLS

High and low pressure controls shall be included for field or factory installation.

### LOW AMBIENT CONTROL

Low ambient control shall be provided to cycle the condenser fan in response to condensing pressure and allow operation to 0 degrees F. The option shall be field or factory installed.

### TIME DELAY CONTROL

Time delay control shall be provided to prevent the compressor from restarting 5 minutes after shutdown. The control shall be field or factory installed.

### LOUVER PANEL KITS

Field or factory installed louver kits shall be provided for condenser coil protection against hail or flying debris.

[ ] Designates Metric Conversions

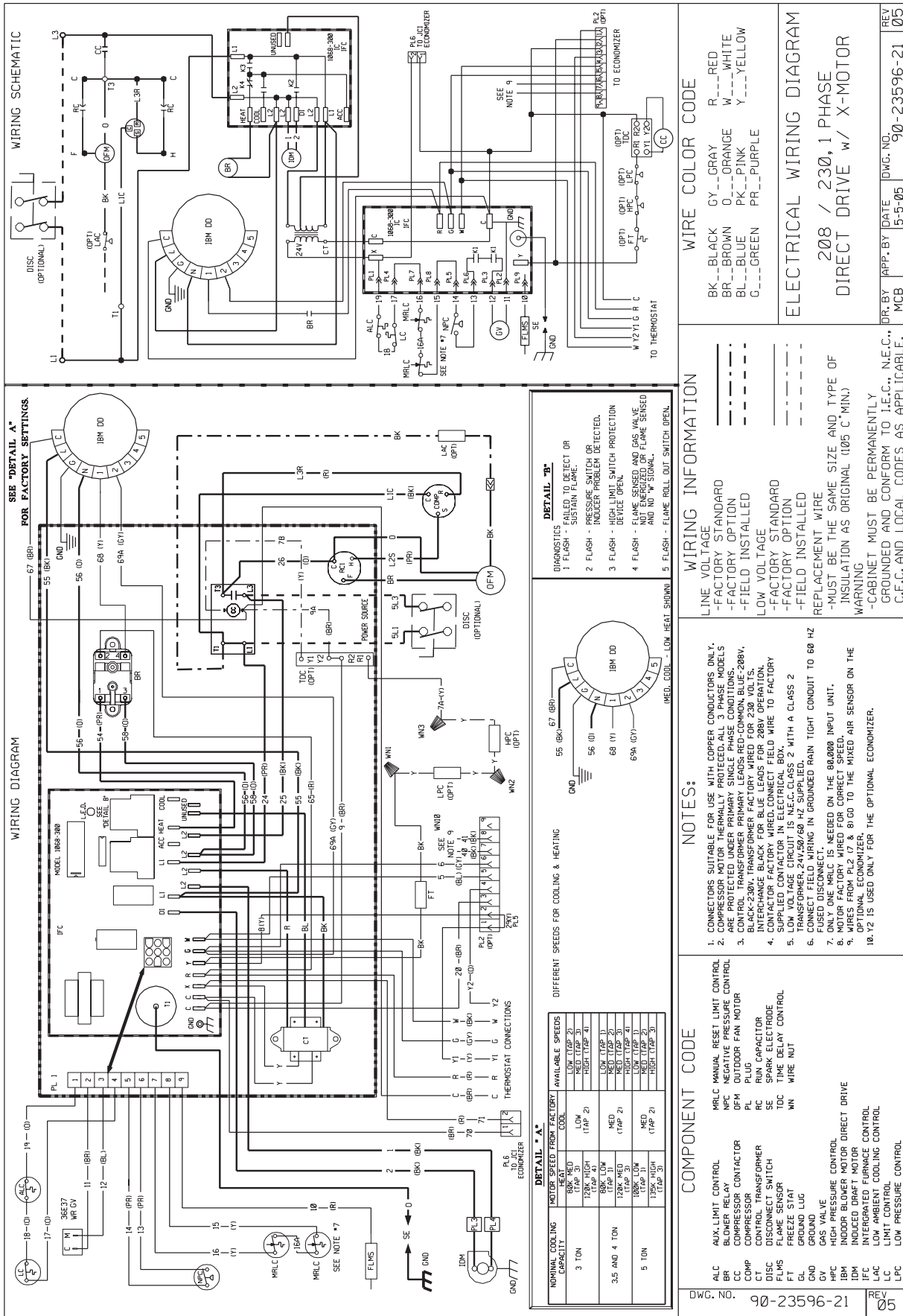

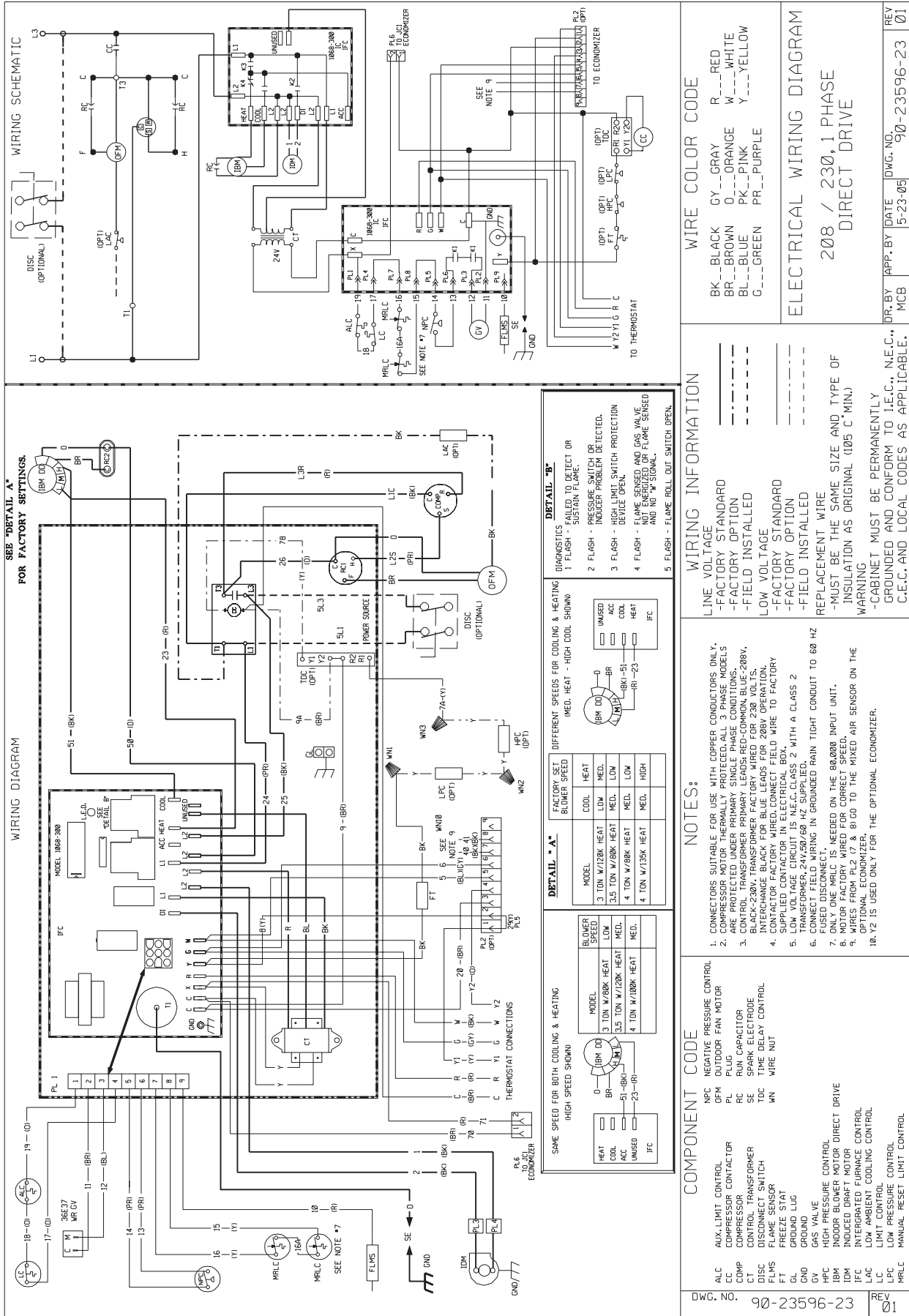

WIRING SCHEMATIC

SEE "DETAIL A" FOR FACTORY SETTINGS.

WIRING DIAGRAM

SEE NOTE #7

**DETAIL "B"**  
 DIAGNOSTICS FOR COOLING & HEATING (MED. HEAT - HIGH COOL SHOWN)  
 1 FLASH - FAILED TO DETECT OR SUSTAIN FLAME.  
 2 FLASH - PRESSURE SWITCH OR INDUCER PROBLEM DETECTED.  
 3 FLASH - HIGH LIMIT SWITCH PROTECTION DEVICE OPEN.  
 4 FLASH - FLAME SENSED AND GAS VALVE AND NO. 12 OPEN.  
 5 FLASH - FLAME ROLL OUT SWITCH OPEN.

**DETAIL "A"**

MODEL	DIFFERENT SPEEDS FOR COOLING & HEATING (MED. HEAT - HIGH COOL SHOWN)	
	COOL	HEAT
3 TON W/120K HEAT	LOW	MED.
3.5 TON W/80K HEAT	MED.	LOW
4 TON W/80K HEAT	MED.	LOW
4 TON W/120K HEAT	MED.	HIGH

MODEL	FACTORY SET BLOWER SPEED	
	COOL	HEAT
3 TON W/120K HEAT	LOW	MED.
3.5 TON W/80K HEAT	MED.	LOW
4 TON W/80K HEAT	MED.	LOW
4 TON W/120K HEAT	MED.	HIGH

**WIRING INFORMATION**

LINE VOLTAGE  
 -FACTORY STANDARD  
 -FIELD INSTALLED

LOW VOLTAGE  
 -FACTORY STANDARD  
 -FIELD INSTALLED

REPLACEMENT WIRE  
 -MUST BE THE SAME SIZE AND TYPE OF INSULATION AS ORIGINAL (105 C MIN.)  
 -CABINET MUST BE PERMANENTLY GROUNDED AND CONFORM TO I.E.C., N.E.C., C.E.C. AND LOCAL CODES AS APPLICABLE.

**NOTES:**

- CONNECTORS SUITABLE FOR USE WITH COPPER CONDUCTORS ONLY.
- COMPRESSOR MOTOR THERMALLY PROTECTED. ALL 3 PHASE MODELS ARE PROTECTED UNDER PRIMARY SINGLE PHASE CONDITIONS.
- CONTROL TRANSFORMER PRIMARY LEADS: RED-COMMON, BLUE-208V, BLACK-230V, TRANSFORMER FACTORY WIRED FOR 230 VOLTS. INTERCHANGE BLACK FOR BLUE LEADS FOR 208V OPERATION.
- COMPLETELY NON-POLARIZED. FIELD WIRE TO FACTORY SUPPLIED INDUCER MOTOR WIRE IS N.E.C. CLASS 2 WITH A CLASS 2 TRANSFORMER. 24V/50/60 HZ SUPPLIED.
- CONNECT FIELD WIRING IN GROUNDED RAIN TIGHT CONDUIT TO 60 HZ FUSED DISCONNECT.
- ONLY ONE MRLC IS NEEDED ON THE 88,000 INPUT UNIT.
- IF THE UNIT IS TO BE USED IN A MIXED AIR SENSOR ON THE OPTIONAL ECONOMIZER.
- ONLY FROM PL 2 (T, Ø 60) TO THE MIXED AIR SENSOR ON THE OPTIONAL ECONOMIZER.
- Ø 12 IS USED ONLY FOR THE OPTIONAL ECONOMIZER.

**COMPONENT CODE**

NFC NEGATIVE PRESSURE CONTROL  
 OFM OUTDOOR FAN MOTOR  
 PL PLUG  
 RC RUN CAPACITOR  
 SE SPARK ELECTRODE  
 TBC TIME DELAY CONTROL WIRE NOT  
 FREEZE STAT  
 GND GROUND LUG  
 GND GROUND  
 GV GAS VALVE  
 HFC HIGH PRESSURE CONTROL  
 INDUCER BLOWER MOTOR DIRECT DRIVE  
 IDM INDUCED DRAFT MOTOR  
 IBM INTEGRATED BURNER CONTROL  
 IFC LOW AMBIENT COOLING CONTROL  
 LAC LIMIT CONTROL  
 LFC LOW PRESSURE CONTROL  
 MRLC MANUAL RESET LIMIT CONTROL

**WIRE COLOR CODE**

BK---BLACK  
 BR---BROWN  
 BL---BLUE  
 G---GREEN

GY---GRAY  
 O---ORANGE  
 PK---PINK  
 PR---PURPLE

R---RED  
 W---WHITE  
 Y---YELLOW

**ELECTRICAL WIRING DIAGRAM**

208 / 230, 1 PHASE  
 DIRECT DRIVE

DWG. NO. 90-23596-23  
 REV 01

APP. BY DATE 15-23-05  
 MCB

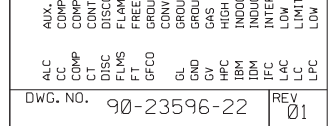
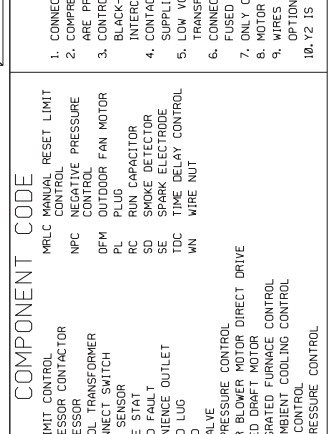
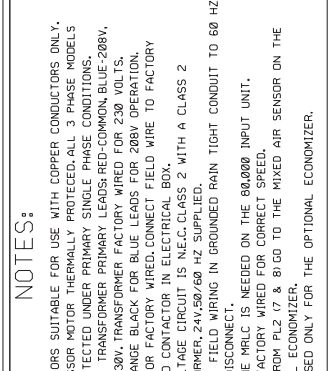
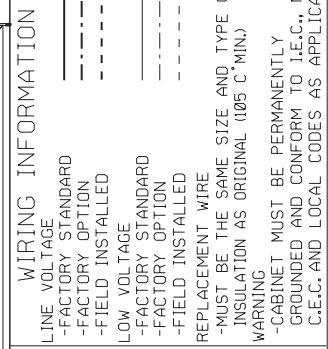
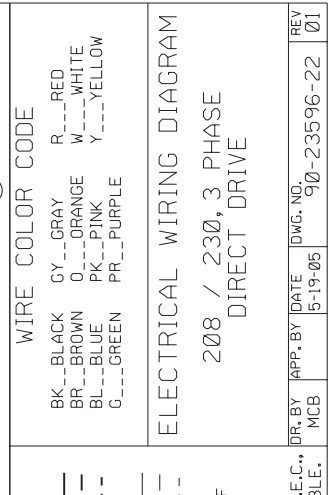
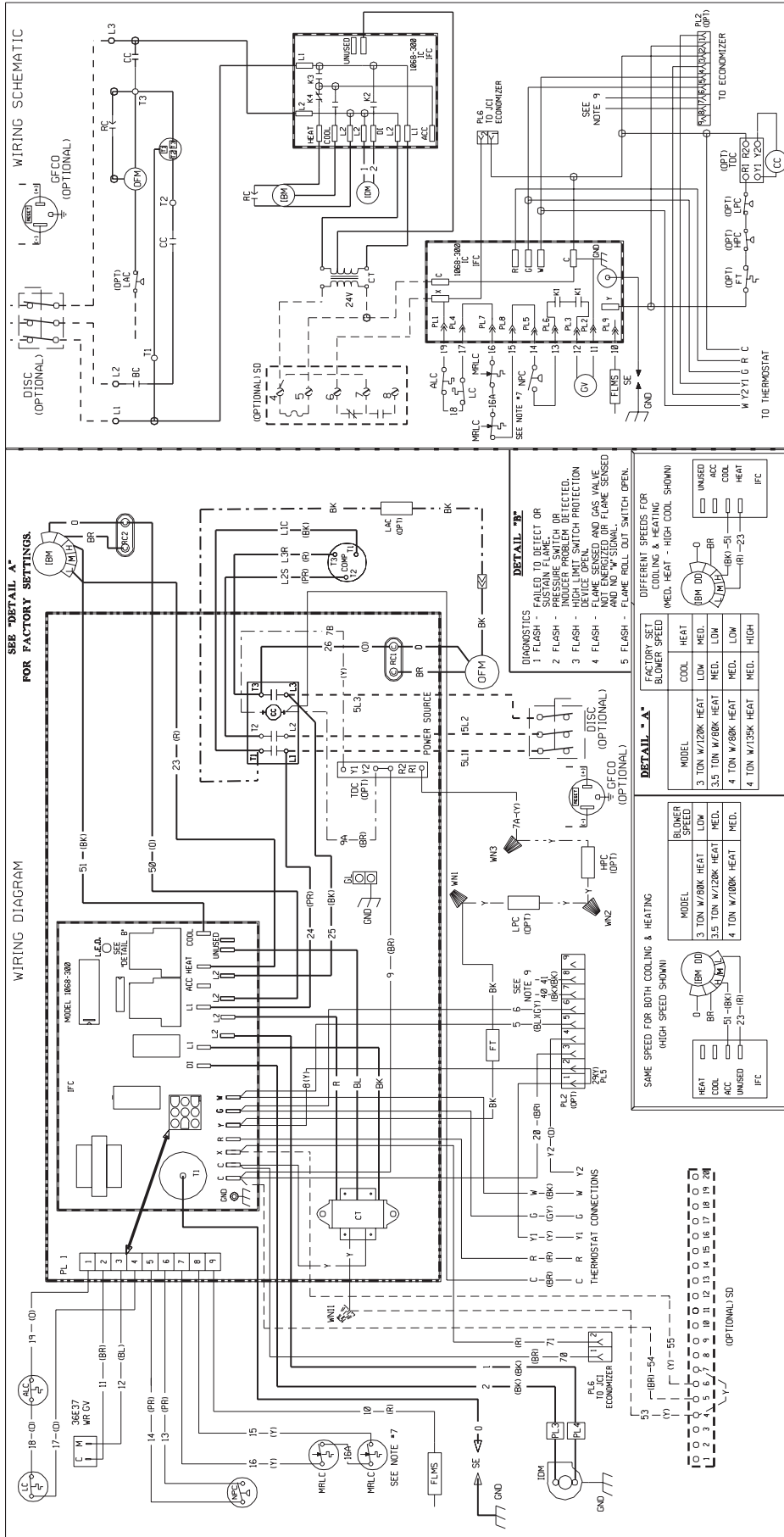

COMPONENT CODE	WIRE COLOR CODE
AUX. LIMIT CONTROL	BK --- BLACK
COMPRESSOR CONTACTOR	GY --- GRAY
COMPRESSOR TRANSFORMER	OR --- ORANGE
DISC	W --- WHITE
DISCONNECT SWITCH	O --- OFF
FLAME SENSOR	PK --- PINK
FREEZE STAT	G --- GREEN
GROUND FAULT	PR --- PURPLE
CONVENIENCE OUTLET	
GROUND LUG	
GROUND	
GAS VALVE	
HIGH PRESSURE CONTROL	
INDOOR BLOWER MOTOR	
INDUCED DRAFT MOTOR	
INTERLOCKED FURNACE CONTROL	
INDOOR COIL	
LIMIT CONTROL	
LOW PRESSURE CONTROL	

**WIRING INFORMATION**

LINE VOLTAGE  
 -FACTORY STANDARD  
 -FACTORY OPTION  
 -FIELD INSTALLED

LOW VOLTAGE  
 -FACTORY STANDARD  
 -FACTORY OPTION  
 -FIELD INSTALLED

REPLACEMENT WIRE  
 -MUST BE THE SAME SIZE AND TYPE OF INSULATION AS ORIGINAL (105 C MIN.)  
 -CABINET MUST BE PERMANENTLY GROUNDED AND CONFORM TO I.E.C., N.E.C., C.E.C. AND LOCAL CODES AS APPLICABLE.

REV	DATE	APP. BY	DWG. NO.
01	5-19-05	MCB	90-23596-22

- NOTES:**
- CONNECTORS SUITABLE FOR USE WITH COPPER CONDUCTORS ONLY.
  - COMPRESSOR MOTOR THERMALLY PROTECTED, ALL 3 PHASE MODELS ARE PROTECTED UNDER PRIMARY SINGLE PHASE CONDITIONS.
  - CONTROL TRANSFORMER PRIMARY LEADS RED-COMMON BLUE-208V, BLACK-230V, TRANSFORMER FACTORY WIRE FOR 230 VOLTS. INTERCHANGE BLACK FOR BLUE LEADS FOR 208V OPERATION.
  - CONTACTOR FACTORY WIRE, CONNECT FIELD WIRE TO FACTORY SUPPLIED CONTACTOR IN ELECTRICAL BOX.
  - LOW VOLTAGE CIRCUIT IS N.E.C. CLASS 2 WITH A CLASS 2 TRANSFORMER, 24V/50V/60 HZ SUPPLIED.
  - CONNECT FIELD WIRING IN GROUNDED RAIN TIGHT CONDUIT TO 60 HZ FUSED DISCONNECT.
  - ONLY ONE MRLC IS NEEDED ON THE 00,000 INPUT UNIT.
  - MOTOR FACTORY WIRE FOR CORRECT SPEED.
  - WIRES FROM PL2 (7 & 8) GO TO THE MIXED AIR SENSOR ON THE OPTIONAL ECONOMIZER.
  - 10, Y2 IS USED ONLY FOR THE OPTIONAL ECONOMIZER.

DIFFERENT SPEEDS FOR COOLING & HEATING BLOWER SPEED	FACTORY USED
MODEL	HEAT
3 TON W/120K HEAT	COOL
3.5 TON W/120K HEAT	HEAT
4 TON W/120K HEAT	LOW
4 TON W/120K HEAT	MED.
4 TON W/120K HEAT	HIGH

DIFFERENT SPEEDS FOR COOLING & HEATING BLOWER SPEED	FACTORY USED
MODEL	HEAT
3 TON W/120K HEAT	COOL
3.5 TON W/120K HEAT	HEAT
4 TON W/120K HEAT	LOW
4 TON W/120K HEAT	MED.
4 TON W/120K HEAT	HIGH

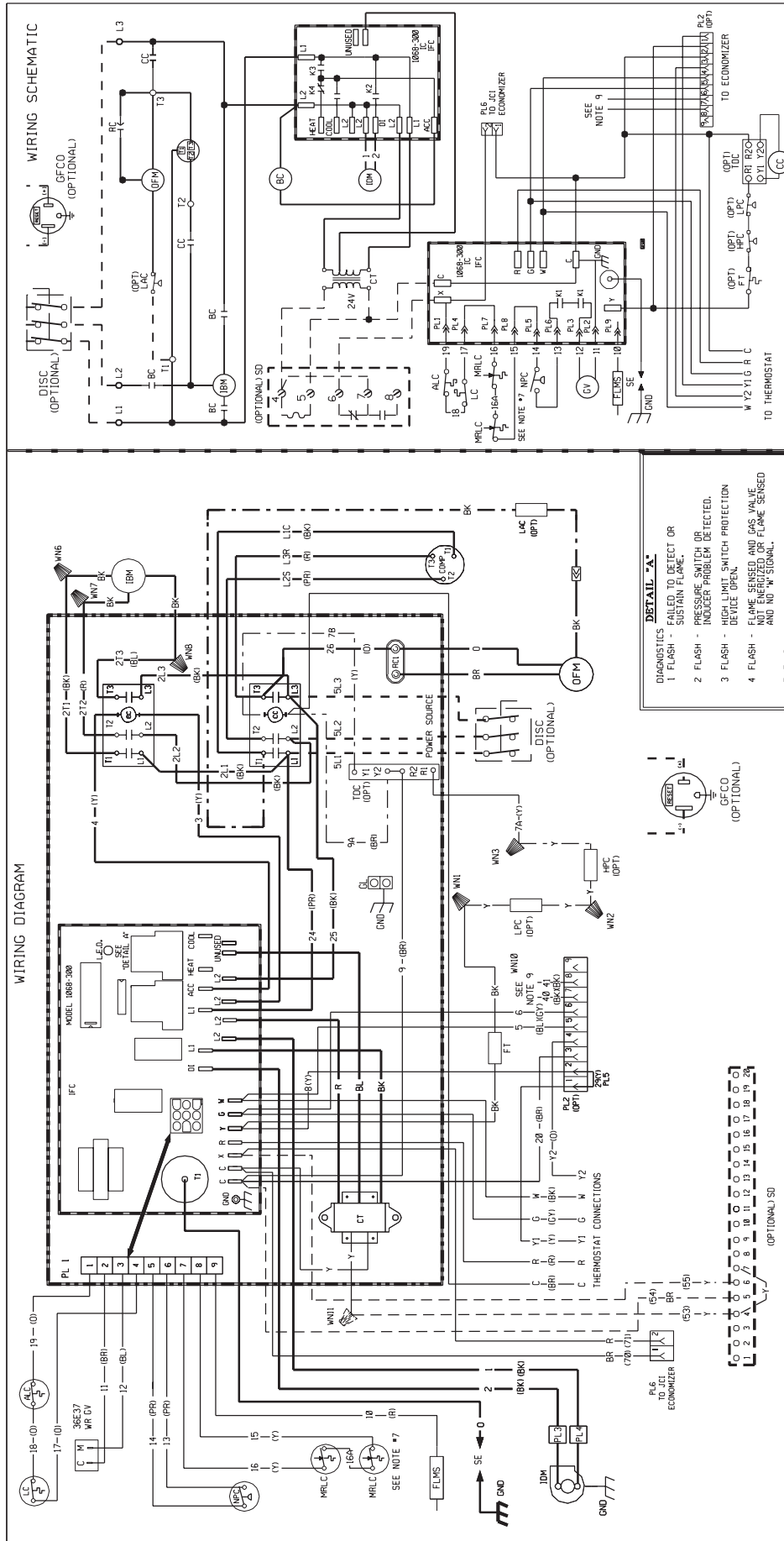

### WIRE COLOR CODE

BK	BLACK	GY	GRAY	R	RED
BR	BROWN	O	ORANGE	W	WHITE
BL	BLUE	PK	PINK	Y	YELLOW
G	GREEN	PR	PURPLE		

### ELECTRICAL WIRING DIAGRAM

208 / 230, 3 PHASE, 60 HZ  
BELT DRIVE

### WIRING INFORMATION

LINE VOLTAGE  
 -FACTORY STANDARD  
 -FACTORY OPTION  
 -FIELD INSTALLED

LOW VOLTAGE  
 -FACTORY STANDARD  
 -FACTORY OPTION  
 -FIELD INSTALLED

REPLACEMENT WIRE  
 -MUST BE THE SAME SIZE AND TYPE OF INSULATION AS ORIGINAL (105 C MIN.)

WARNING  
 -CABINET MUST BE PERMANENTLY GROUNDED AND CONFORM TO I.E.C., N.E.C., C.E.C. AND LOCAL CODES AS APPLICABLE.

### COMPONENT CODE

ALC	AIR LIMIT CONTROL	LFC	LOW FLOW CONTROL
BC	BLOWER CAPACITOR	MRLC	MIXER PRESSURE LIMIT CONTROL
COMP	COMPRESSOR	NPC	NEGATIVE PRESSURE CONTROL
CT	CONTROL TRANSFORMER	ODM	OUTDOOR FAN MOTOR
DISC	DISCONNECT SWITCH	PL	PLUG
FLM	FLAME SENSOR	RUN	RUN CAPACITOR
FT	FREEZE STAT	SD	SMOKE DETECTOR
GFCCO	GROUND FAULT CONVENIENCE OUTLET	SE	SPARK ELECTRODE
GL	GROUND LUG	TDC	TIME DELAY CONTROL
GN	GROUND	WN	WIRE NUT
GV	GAS VALVE		
HPC	HIGH PRESSURE CONTROL		
IBM	INDOOR BLOWER MOTOR DIRECT DRIVE		
IDM	INDOOR DRAFT MOTOR		
IFC	INTERGRATED FURNACE CONTROL		
LAC	LOW AMBIENT COOLING CONTROL		

DWG. NO. 90-23596-26  
 REV 02

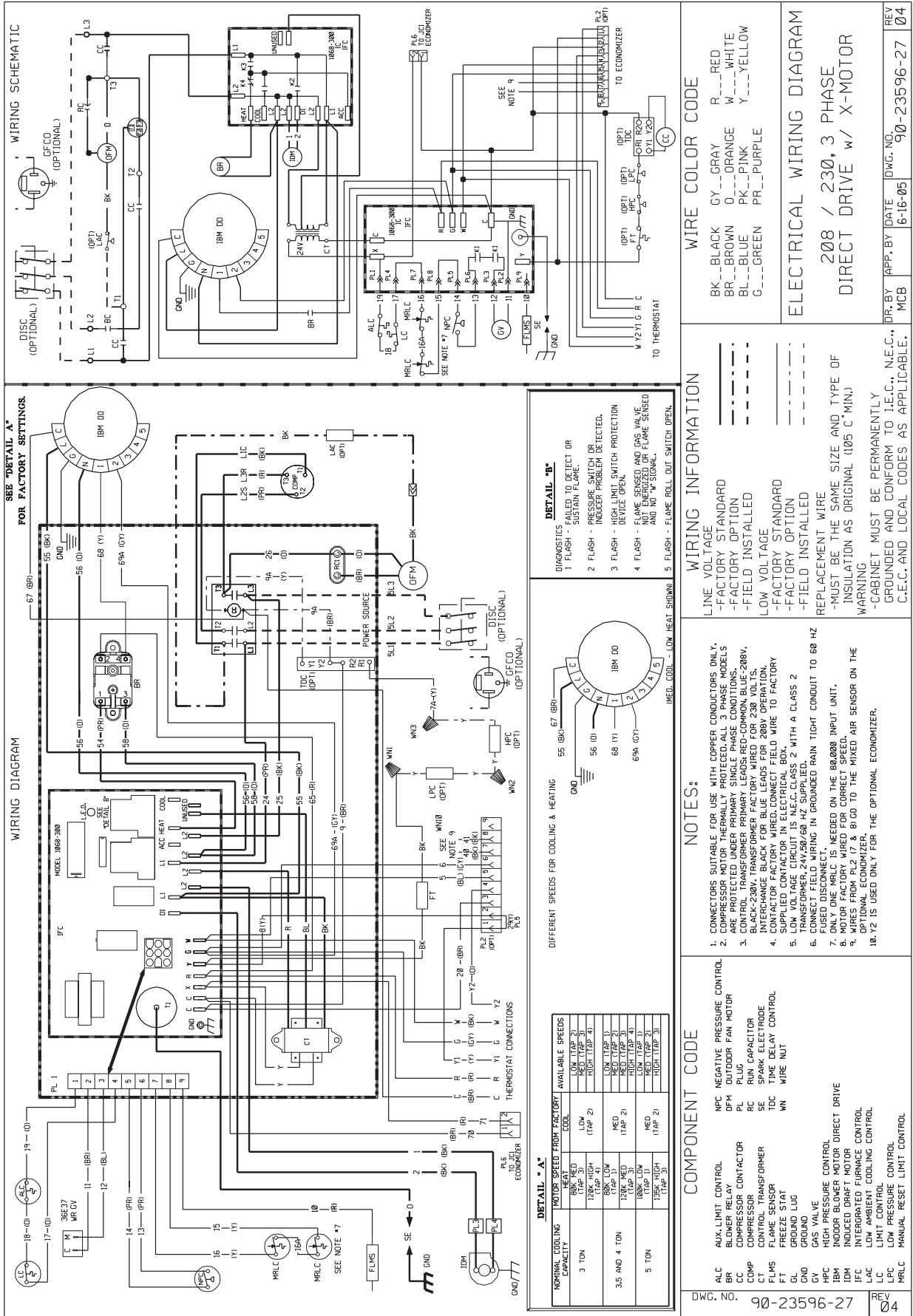

WIRING SCHEMATIC

WIRING DIAGRAM

DETAIL A - FOR FACTORY SETTINGS

DETAIL B - DIAGNOSTICS

COMPONENT CODE

WIRE COLOR CODE

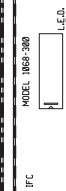
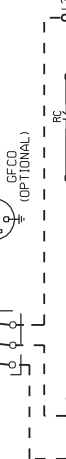

NOMINAL COOLING CAPACITY	MOTOR SPEED FROM FACTORY	AVAILABLE SPEEDS
3 TON	HEAT (TAP 3)	LOW (TAP 3)
	COOL (TAP 2)	MED (TAP 4)
		HIGH (TAP 4)
3.5 AND 4 TON	88K LOW (TAP 1)	LOW (TAP 1)
	120K MED (TAP 2)	MED (TAP 2)
5 TON	120K MED (TAP 1)	LOW (TAP 1)
	188K LOW (TAP 2)	MED (TAP 2)
	240K HIGH (TAP 3)	HIGH (TAP 3)

LINE VOLTAGE	WIRE COLOR CODE
-FACTORY STANDARD	BK...BLACK
-FACTORY OPTION	GY...GRAY
-FIELD INSTALLED	BR...BROWN
LOW VOLTAGE	O...ORANGE
-FACTORY STANDARD	BL...BLUE
-FACTORY OPTION	PK...PINK
-FIELD INSTALLED	G...GREEN
REPLACEMENT WIRE	PR...PURPLE
-MUST BE THE SAME SIZE AND TYPE OF INSULATION AS ORIGINAL (105 C MIN)	

WIRE COLOR CODE

ELECTRICAL WIRING DIAGRAM

208 / 230, 3 PHASE DIRECT DRIVE w/ X-MOTOR

DR. BY DATE

APP. BY DATE

DWG. NO.

REV

04

90-23596-27

90-23596-27

90-23596-27

90-23596-27

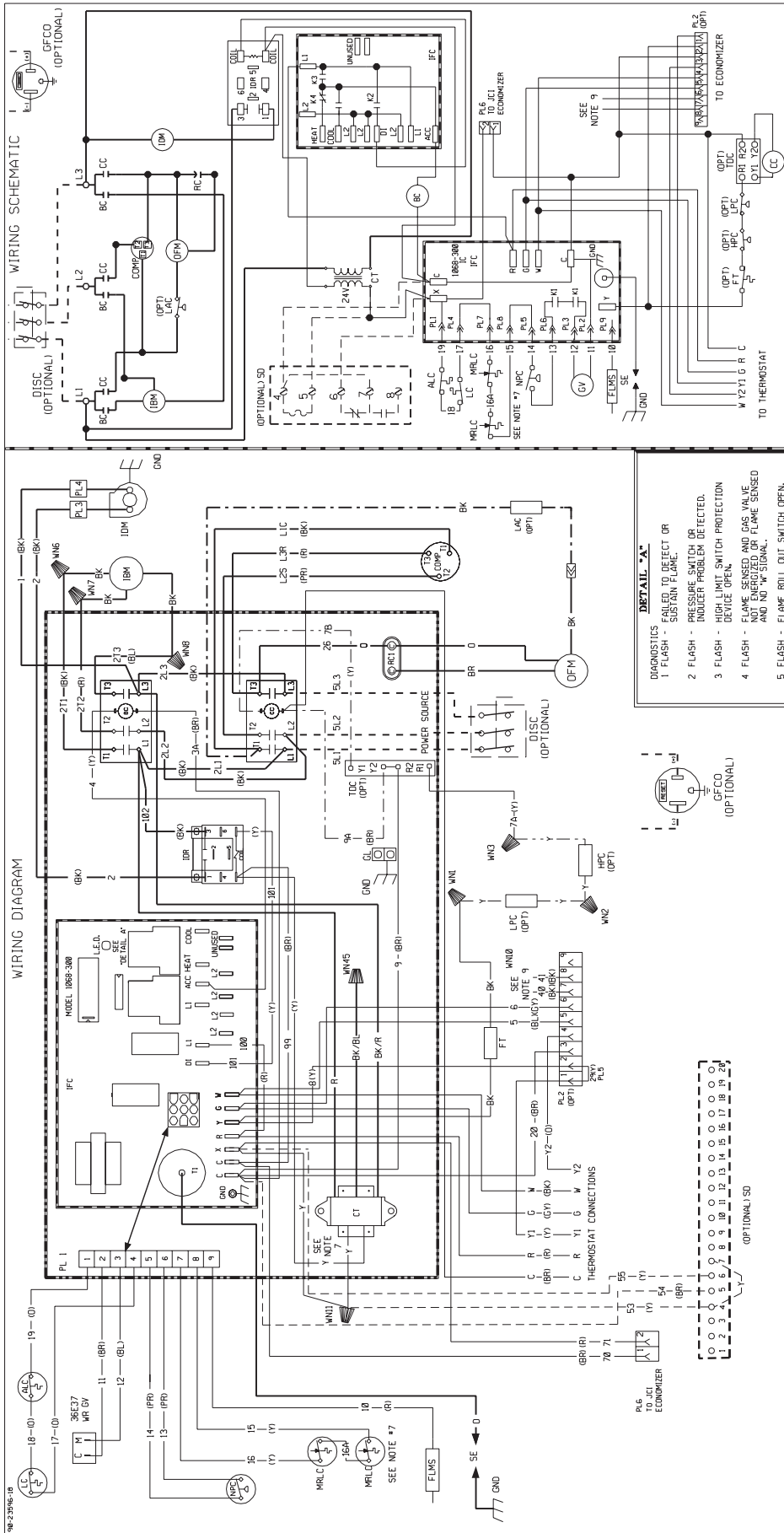

COMPONENT CODE		WIRE COLOR CODE	
AUX LIMIT CONTROL	LPC	BLACK	GY
BLOWER CONTACTOR	LFC	BROWN	0
COMPRESSOR CONTACTOR	MRLC	BLUE	PK
COMPRESSOR TRANSFORMER	DFM	GREEN	PR
CONTROL TRANSFORMER	PLUG		
DISC	PT		
FLMS	RC		
FREZE STAT	RD		
GROUND FAULT	SD		
CONVENIENCE OUTLET	SE		
GROUND LUG	TD		
GN	WIRE NOT USED		
GV	GAS VALVE		
IBM	INDOR BLOWER MOTOR		
IBM	INDUCED DRAFT MOTOR		
IBM	INDUCED DRAFT RELAY		
JFC	INTERGRATED FURNACE CONTROL		
LAC	LOW AMBIENT COOLING CONTROL		

LINE VOLTAGE	WIRING INFORMATION
-FACTORY STANDARD	CONNECTORS SUITABLE FOR USE WITH COPPER CONDUCTORS ONLY.
-FACTORY OPTION	COMPRESSOR MOTOR THERMALLY PROTECTED. ALL 3 PHASE MODELS ARE PROTECTED UNDER PRIMARY SINGLE PHASE CONDITIONS.
-FIELD INSTALLED	CONTRACTOR FACTORY WIRE CONNECT FIELD WIRE TO FACTORY SUPPLIED CONTACTOR IN ELECTRICAL BOX.
LOW VOLTAGE	LOW VOLTAGE CIRCUIT IS N.E.C. CLASS 2 WITH A CLASS 2 TRANSFORMER, 24V/50/60 HZ SUPPLIED.
FACTORY STANDARD	CONNECT FIELD WIRING IN GROUNDING RAIN TIGHT CONDUIT TO 60 HZ FUSED DISCONNECT.
FACTORY OPTION	ONLY ONE MRLC IS NEEDED ON THE 86,000 INPUT UNIT.
-FIELD INSTALLED	POWER TRANSFORMER PRIMARY LEADS: BLUE-COMMON BK/PED-460V, 60 HZ / 380V, 50 HZ; RED-575V, 60 HZ / 415V, 50 HZ.
REPLACEMENT WIRE	WIPES FROM PL2 (7 & 8) GO TO THE MIXED AIR SENSOR ON THE OPTIONAL ECONOMIZER.
-MUST BE THE SAME SIZE AND TYPE OF INSULATION AS ORIGINAL (105 C MIN.)	9. Y2 IS USED ONLY FOR THE OPTIONAL ECONOMIZER.

WIRE COLOR CODE	WIRE COLOR CODE
BK	BLACK
BR	BROWN
BL	BLUE
G	GREEN
GY	GRAY
0	ORANGE
PK	PINK
PR	PURPLE
R	RED
W	WHITE
Y	YELLOW







**BEFORE PURCHASING THIS APPLIANCE, READ IMPORTANT ENERGY COST AND EFFICIENCY INFORMATION AVAILABLE FROM YOUR RETAILER.**

### **GENERAL TERMS OF LIMITED WARRANTY**

Rheem will furnish a replacement for any part of this product which fails in normal use and service within the applicable periods stated, in accordance with the terms of the limited warranty.

**For Complete Details of the Limited Warranty, Including Applicable Terms and Conditions, See Your Local Installer or Contact the Manufacturer for a Copy.**

Heat Exchanger	
Factory Standard .....	Ten (10) Years
Stainless Steel/1-Phase Models/ Residential Applications .....	Limited Lifetime
Stainless Steel/1-Phase & 3-Phase Models/ Commercial Applications .....	Twenty (20) Years
Compressor .....	Five (5) Years
Any Other Part	
1-Phase Models .....	Five (5) Years
3-Phase Models .....	One (1) Year

**Before proceeding with installation, refer to installation instructions packaged with each model, as well as complying with all Federal, State, Provincial, and Local codes, regulations, and practices.**

**Rheem Heating,  
Cooling and  
Water Heating**

P.O. Box 17010, Fort Smith, AR 72917



*"In keeping with its policy of continuous progress and product improvement, Rheem reserves the right to make changes without notice."*