

Electric Tankless Water heaters

INSTALLATION INSTRUCTIONS & HOME OWNERS MANUAL

IMPORTANT SAFETY INFORMATION

When installing or using any high voltage electrical appliance, basic safety precautions should always be followed. Under no circumstance should you attempt to clean, install, inspect, repair, disassemble or otherwise service this water heater, without first shutting off all power to the unit directly at the circuit breaker box. **SERIOUS BODILY INJURY OR DEATH COULD OCCUR IF YOU IGNORE THIS WARNING.**

THIS PRODUCT SHOULD BE INSTALLED BY A QUALIFIED ELECTRICIAN AND A QUALIFIED PLUMBER IN ACCORDANCE WITH ALL NATIONAL, STATE, PROVINCIAL AND LOCAL ELECTRICAL & PLUMBING CODES.

PLEASE READ THESE INSTRUCTIONS THOROUGHLY AND COMPLETELY PRIOR TO INSTALLATION & USE. FAILURE TO DO SO COULD CAUSE PROPERTY DAMAGE, SERIOUS INJURY, OR DEATH.

This manual should be given to the homeowner after installation and should be retained for future reference.

Proposition 65 Warning: This product contains chemicals known to the State of California to cause cancer, birth defects or other reproductive harm



Tested and certified by the Water Quality Association against NSF/ANSI 372 for lead free compliance.



Recognize this symbol as an indication of Important Safety Information!

DO NOT destroy this manual. Please read carefully and keep it in a safe place for future reference

IMPORTANT SAFETY INFORMATION.

READ ALL INSTRUCTIONS BEFORE USING



DANGER! **WATER TEMPERATURE SAFETY SETTING**

Safety and energy conservation are factors to be considered when selecting the water temperature setting of water heater's thermostat. Water temperatures above the 125°F (52°C) can cause severe burns or death from scalding. Be sure to read and follow the warnings outlined on the label pictured below. This label is also located on the water heater near the thermostat access panel.

! DANGER



Water temperature over 125°F can cause severe burns instantly or death from scalds.

Children, disabled and elderly are at highest risk of being scalded.

See instruction manual before setting temperature at water heater.

Feel water before bathing or showering.

Temperature limiting valves are available, see manual.

Notice: Mixing valves are recommended for reducing point of use water temperature by mixing hot and cold water in branch water lines. It is recommended that a mixing valve complying with the Standard for Temperature Actuated Mixing Valves for Hot Water Distribution Systems, ASSE 1017 be installed.

Time/Temperature Relationship in Scalds

Water Temperature	Time to Produce a Serious Burn
120°F (49°C)	More than 5 minutes
125°F (52°C)	1 1/2 to 2 minutes
130°F (54°C)	About 30 seconds
135°F (57°C)	About 10 seconds
140°F (60°C)	Less than 5 seconds
145°F (63°C)	Less than 3 seconds
150°F (66°C)	About 1 1/2 seconds
155°F (68°C)	About 1 second

Table courtesy of Shriners Burn Institute

The chart shown above may be used as a guide in determining the proper water temperature for your home.



DANGER Households with small children, disabled, or elderly persons may require a 120°F (49°C) or lower thermostat setting to prevent contact with "HOT" water. The temperature of the water in the heater is regulated by the electronic control on the front of the water heater. To comply with safety regulations the thermostat was set at 120°F (49°C) before the water heater was shipped from the factory.

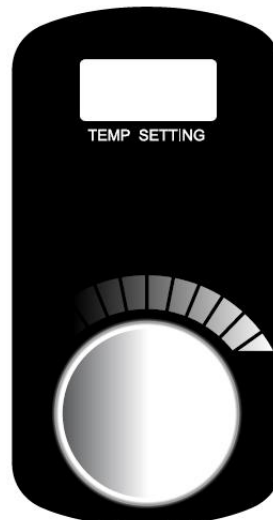

Please consult Section 10 to learn more about setting your heaters temperature. Rotate right for higher temperature (up to 140°F (60°C) or rotate left for cooler temperature (as low as 80°F (27°C) will be displayed on the screen above the knob.

ABOUT YOUR TANKLESS WATER HEATER

Congratulations on the purchase of your Electric Tankless Water Heater! You have purchased the most technologically-advanced electric tankless water heater on the market today.

Your new electric tankless water heater features advanced water flow rate and temperature sensors designed to modulate power to the heating elements to maintain a user-selected output water temperature between 80°F (27°C) and 140°F (60°C) (subject to incoming water temperature and power of the selected heaters).

To get the best performance and energy savings from your electric tankless water heater, it is important that it be installed in accordance with our instructions and the electrical and plumbing codes applicable to your area, and that you read this manual thoroughly for important operating instructions and tips.

If you have questions at any time, please contact us directly at:

Manufacturer's National Service Department
400 Captain Neville Dr. Waterbury, CT 06705 Phone: 1-(800)-374-8806.

CONTENTS

1. BEFORE INSTALLATION
2. SELECTING A LOCATION TO INSTALL
3. MOUNTING YOUR WATER HEATER
4. PLUMBING INSTALLATION
5. ELECTRICAL INSTALLATION
6. SIZING GUIDE
7. GENERAL OPERATING INSTRUCTIONS
8. MAINTENANCE
9. TROUBLE SHOOTING GUIDE
10. USER INTERFACE

1- BEFORE INSTALLATION

PLEASE READ THESE INSTRUCTIONS THOROUGHLY AND COMPLETELY PRIOR TO INSTALLATION & USE. FAILURE TO FOLLOW INSTRUCTIONS COULD CAUSE PROPERTY DAMAGE, SERIOUS PERSONAL INJURY, OR DEATH.

By installing this product, you acknowledge the terms of the manufacturer's warranty. Once the heater is installed, do not return product to the place of purchase. If you have any questions regarding the warranty or product return policies, please contact Manufacturer's national service department at 1-(800) 374-8806.

Inspect all components. The contents of your box should include one of the following units:

- 8kW
- 11kW
- 13kW
- 18kW
- 24kW
- 27kW
- 36kW

4- PLUMBING INSTALLATION

Please follow all plumbing instructions carefully. We recommend that this product be installed by a licensed and qualified plumber in accordance with all applicable national, state, provincial, and local plumbing codes.

Installation Instructions

STEP 1: Thoroughly flush cold supply line of debris and connect the HOT WATER line to the water heater OUTLET located on the left side of the heater when facing unit. Connect the COLD WATER line to the water heater marked COLD WATER INLET on the right side when facing unit.

STEP 2: After tightening both fittings at the water heater, open several hot water faucets and allow water to run through the water heater for at least 2 to 3 minutes. This process purges all the air from the water lines and MUST be performed prior to turning on the power at the unit. FAILURE TO FOLLOW THIS STEP CAN CAUSE PERMANENT DAMAGE TO THE HEATING ELEMENTS. If any maintenance is performed on the water heater or the home's plumbing system that may introduce air into the plumbing pipes, it is important to turn the power off to the water heater and purge the air out of the lines before allowing the unit to power up.

STEP 3: Carefully inspect all connections, unions, and the pressure relief valve (if installed) for leaks.

IMPORTANT NOTES:

1. Do not solder any pipes with the unit connected to pipes – heat from soldering may damage the flow sensor. Doing so will void the warranty.
2. This automatic tankless water heater is equipped with both computer-controlled and electro-mechanical auto resetting thermostat switches for high-limited temperature protection. Since this product does not use a storage tank, the use of a temperature pressure relief valve (T&P) is not required for most installations. UL Standard 499 does NOT require that a pressure relief valve be used. However, a T&P valve may be required to meet installation codes in your area. If one is required, install the pressure relief valve in accordance with local codes and ensure that it operates correctly and that air is purged from the valve prior to installing the water heater. When connecting to Flex or High Temperature CPVC pipe, we recommend that a T&P valve be used for added safety.
Please note: Installations in the Commonwealth of Massachusetts and State of Kentucky require a pressure relief valve. Please check your local installation codes for any special requirements.
3. The maximum operating water pressure is 150 PSI (1035 kPA). If the water pressure is higher, a pressure reducing valve must be installed on the main incoming water supply line prior to installing the electric tankless water heater.
4. Flexible water heater hoses are recommended to be used with your water heater as part of the installation. When connecting the inlet water pipe to the unit, make sure to use a wrench to hold the unit's connection, and another wrench to tighten, so that the flow sensor on the unit will not be loosened or damaged. Serious internal damage to the water heater can occur if the inlet or outlet connections are over tightened or if solder connections were made.
5. We recommend that a manual shut-off valve (ball valve) is installed on the inlet and outlet of the water heater so that there is a convenient shut-off point available in the event that future maintenance or servicing is required. It is extremely important to flush the lines to eliminate all plumbing paste or residue in the lines caused by any welding or soldering before connecting pipes to the water heater.

We recommend that all the water pipes or hoses within 3' (1m) of the inlet and outlet connections be rated for high temperature applications with a 150°F (66°C) minimum.



WARNING-CHECK FOR LEAKS BEFORE PROCEEDING TO ELECTRICAL INSTALLATION

5- ELECTRICAL INSTALLATION



WARNING Manufacturer recommends that this product be installed by a licensed and qualified electrician in accordance with all applicable national, state, provincial, and local electrical codes. As with all electrical appliances, under no circumstances should you attempt to install, repair or disassemble this water heater without first shutting off all power to the unit directly at the fuse or breaker box. **Make sure to shut off all breakers. SERIOUS BODILY INJURY OR DEATH COULD OCCUR IF YOU IGNORE THIS WARNING.**

All wiring (wire gauge) and circuit protection (breakers) must comply with the U.S. National Electrical Code (NEC) in the USA, or the Canadian Electrical Code (CEC) in Canada. Failure to do so could result in property damage and/or personal injury, and void your warranty. Note: The Canadian Electrical Code generally requires that all supply wires and corresponding circuit protection used for domestic hot water heating and hydronic heating applications be sized to a minimum of 125% of the maximum current rating of the heater (see heater specifications below for details).

Before installing this product, ensure that the home has sufficient electrical power available to handle the maximum amperage load of the applicable heater.

IMPORTANT NOTES:

8kW, 11kW and 13kW heaters require 1 set of wire and ground (**see wiring diagram**)

18kW heater requires 2 sets of wire and ground (**see wiring diagram**)

24kW and 27kW heaters require 3 sets of wire and ground (**see wiring diagram**)

36kW heater requires 4 sets of wire and ground (**see wiring diagram**)

Please see electrical specifications by heater input and wiring diagram on the next page for additional electrical information.

Each set of wires must be connected to its own individual double pole breaker.

Installation Instructions

STEP 1: Take each wire pair and connect them to one breaker (see wiring diagram). Make sure that each breaker is connected with one black wire and one red wire

STEP 2: Using a suitable wire gauge that meets all applicable electrical codes for the size of the breakers used, run the correct sets of wire from the home's main breaker panel to the tankless water heater.

STEP 3: A separate ground conductor for each incoming circuit is required.

STEP 4: DOUBLE CHECK the electrical connections to make sure they are correct and that all wire connections are tight and secure. Also confirm that the correct breaker size and wire gauge has been used and confirm that the unit has been connected to a ground in accordance with applicable codes.

STEP 5: Confirm that all the air has been purged from the water lines prior to turning on power to the unit. Refer to STEP 2 in the plumbing installation section.



CAUTION Ensure that you have made the correct connections. You must follow the wire connection as shown to ensure proper operation of the unit. If you mix up one set of wires with another, the unit will not operate correctly even though it turns on and otherwise appears to function properly.

The water heater is now installed and ready to use! Follow the General Operating Instructions to complete the setup. We highly recommend that this is done with the homeowner present.

Electrical Specifications by Heater Input

HEATER INPUT	8kW	11kW	13kW	18kW	24kW	27kW	36kW
ELEMENTS	1	2	2	2	3	3	4
VOLTAGE	240 V	240 V	240 V	240 V	240 V	240 V	240 V
MAX kW	8 kW	11 kW	13 kW	18 kW	24 kW	27 kW	36 kW
KW PER ELEMENT	8 kW	5.5 kW	6.5 kW	9 kW	8 kW	9 kW	9 kW
MAX AMPERAGE DRAW	33 AMPS	46 AMPS	54 AMPS	75 AMPS	100 AMPS	112.5 AMPS	150 AMPS
REQUIRED BREAKERS	1 x 40 AMP	1 X 60 AMP	1 X 60 AMP	2 X 40 AMP	3 x 40 AMP	3 X 40 AMP	4 X 40 AMP
REQUIRED WIRE GAUGE	1 x 8 AWG	1 x 6 AWG	1 x 6 AWG	2 X 8 AWG	3 x 8 AWG	3 X 8 AWG	4 X 8 AWG

Wiring Diagram

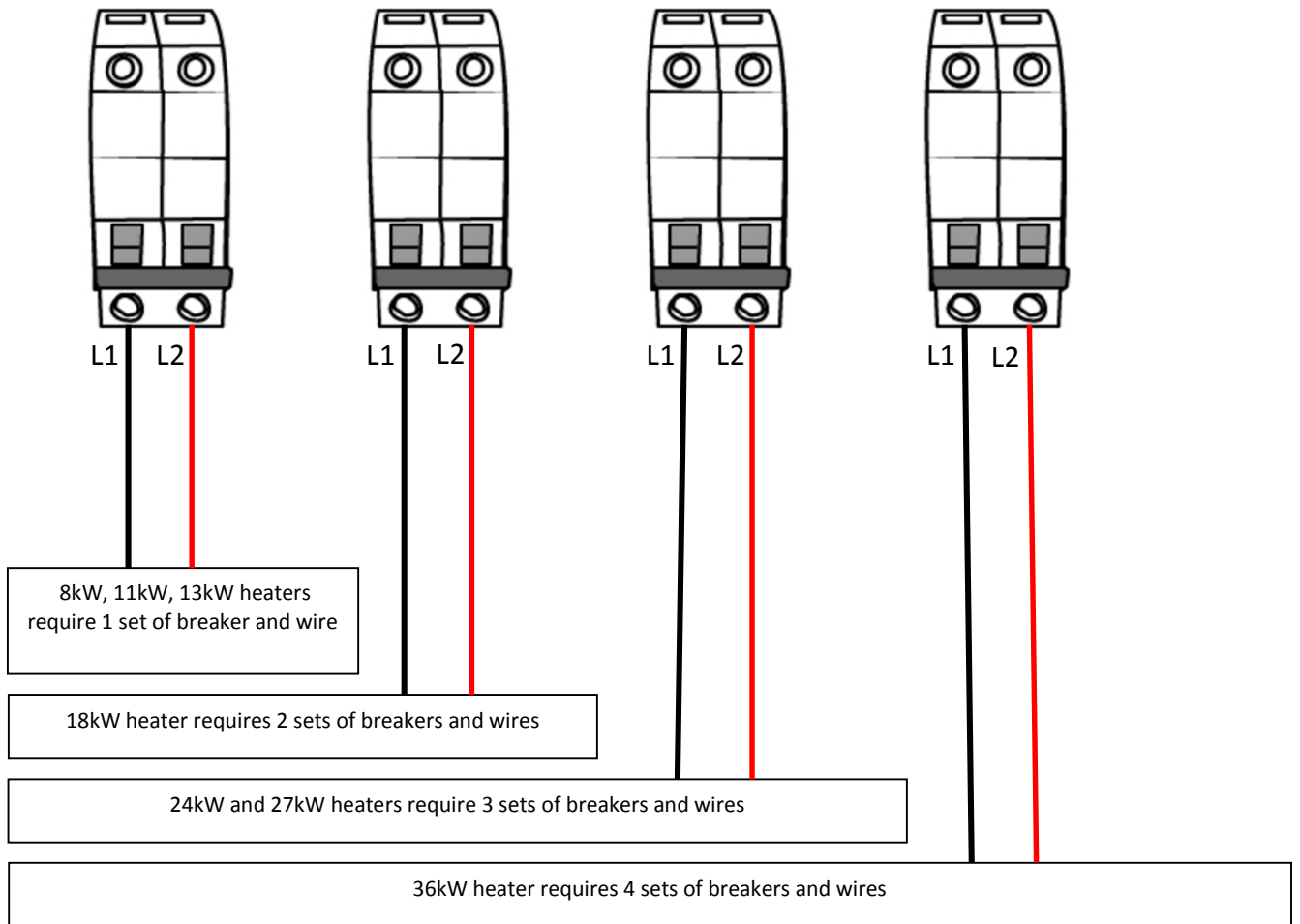

6- SIZING GUIDE

The chart below indicates maximum temperature rise for a given flow rate

+ Temperature electronically limited setting on adjustable thermostat on front cover

	ACTIVATION	MAX	MAXIMUM TEMPERATURE RISE °F (C°)								
	FLOW	FLOW	1(3.8)	1.5(5.7)	2(7.6)	3(11.4)	4(15.1)	5(18.9)	6(22.7)	7(26.5)	8(30.3)
kW	GPM (LPM)	GPM (LPM)	GPM(LPM)	GPM(LPM)	GPM(LPM)	GPM(LPM)	GPM(LPM)	GPM(LPM)	GPM(LPM)	GPM(LPM)	GPM(LPM)
8	.3(1.1)	5(18.9)	55(31)	36(20)	27(15)	18(10)	14(8)	11(6)	9(5)	8(4)	7(4)
11	.3(1.1)	5(18.9)	77(43)	50(28)	38(21)	25(14)	19(11)	15(8)	13(7)	11(6)	9(5)
13	.3(1.1)	5(18.9)	89(49)	59(33)	44(24)	30(17)	22(12)	18(10)	15(8)	13(7)	11(6)
18	.3(1.1)	7(26.5)	+	82(46)	61(34)	41(23)	31(17)	25(14)	20(11)	18(10)	15(8)
24	.3(1.1)	7(26.5)	+	+	82(46)	55(31)	41(23)	33(18)	27(15)	23(13)	20(11)
27	.3(1.1)	7(26.5)	+	+	92(51)	61(34)	46(26)	37(21)	31(17)	26(14)	23(13)
36	.3(1.1)	8(30.9)	+	+	+	82(46)	61(34)	49(27)	41(23)	35(19)	31(17)

FLOW REGULATOR – OPTIONAL

To ensure the optimal temperature output and overall performance of your tankless water heater you may require a flow regulator. These flow regulators are installed on the outlet connection of your tankless water heater and limit the maximum volume coming out of your unit to a specified flow rate to prevent the exit temperature from becoming too cool. To learn more about flow regulators or find out how to purchase one for your tankless water heater contact Manufacturer's national service department at 1-(800)-374-8806.

Steps for Choosing a Flow Regulator

1. Find your heater input in the chart on the left
2. Choose the column with the inlet water temperature closest to your geographical location
3. Take the GPM or gallons per minute you find and match it with the corresponding flow regulator on the right

	Inlet Water Temperature GPM(LPM)				Part Number	Maximum Flow Rate GPM(LPM)	Connection Size
	40°(4°C)	50°F(10°C)	60°F(16°C)	70°F(21°C)			
8kW	1.0 (3.7)	1.0 (3.7)	1.0 (3.7)	1.5 (5.7)	ECO IFR-1-2	1.0 (3.7)	1/2" Compression
11kW	1.0 (3.7)	1.0 (3.7)	1.5 (5.7)	2.0(7.6)		1.5 (5.7)	1/2" Compression
13kW	1.0 (3.7)	1.0 (3.7)	1.5 (5.7)	2.0(7.6)		2.0(7.6)	1/2" Compression
18kW	2.0(7.6)	2.0(7.6)	2.0(7.6)	3.0(11.4)	ECO IFR-3-4	2.0(7.6)	3/4" NPT
24kW	2.0(7.6)	2.0(7.6)	3.0(11.4)	4.0(15.1)		3.0(11.4)	3/4" NPT
27kW	2.0(7.6)	3.0(11.4)	4.0(15.1)	5.0(18.9)		4.0(15.1)	3/4" NPT
36kW	3.0(11.4)	4.0(15.1)	5.0(18.9)	5.0(18.9)		4.0(15.1)	3/4" NPT

*Selection based on inlet temperature above and outlet temperature of 105°F (41°C)

7- GENERAL OPERATING INSTRUCTIONS

Operating your new tankless water heater is similar to using any traditional water heating system. However, it is very important that you carefully read all of the setup procedures and operating instructions and tips to ensure the maximum performance and energy savings from your new water heater. We recommend that all members of the household read these General Operating Instructions.

How your new water heater works: Your tankless water heater does not store hot water like a conventional tank-type water heater. It contains heating elements that are capable of heating water on-demand. As soon as you turn on a hot water faucet, a sophisticated flow sensor recognizes that you have turned on the water. This sensor measures flow rate while another sensor measures the incoming water temperature. This information is transmitted continually to the computer logic controls which decide how much power to send to the heating elements to heat the water to your desired temperature. Once the water faucet is turned off your water heater will turn off as well.

Water Quality: Quality of water should be taken into consideration when installing and maintaining the water heater. Water conditions outside the recommended levels outlined below are not permitted and can damage the water heater. Manufacture reserves the right to deny any warranty claim regarding damage suffered due to use in water conditions not in accordance with the table below.

If water heater is installed in an area that is known to have hard water that cause scale build-up, the water must be treated and/or the heater exchanger flushed regularly to prevent damage to heat exchanger and/or heating elements.

A water treatment device or water softener should be installed to maintain optimal performance of the water heater in hard water areas. Contact customer service for additional information on these accessory kits.

pH	Total Dissolved Solids (TDS)	Free Carbon Dioxide (CO ₂)	Total Hardness	Aluminum	Chloride	Copper	Iron	Manganese	Zinc
6.5 - 8.5	Up to 500 mg/L	Up to 500 mg/L	Up to 200 mg/L	0.05 to 0.2 mg/L	Up to 250 mg/L	Up to 1.0 mg/L	Up to 0.3 mg/L	Up to 0.05 mg/L	Up to 5 mg/L

8- MAINTENANCE

To ensure maximum performance of your water heater and to reduce the risk of a water leak, we recommend the following maintenance:

Inspect the connections on the inlet and outlet of the water heater at least on an annual basis for any signs of damage or failure. Any signs of damage, cracks, leakage or weakness should be addressed. Take care not to over tighten the connections. Serious internal damage to your water heater can occur if you over tighten the water heater connections at the unit.

IMPORTANT NOTES:

 **DANGER** As with all electrical appliances, under no circumstances should you attempt to install, repair or disassemble this water heater without first shutting off all power to the unit directly at the fuse or circuit breaker. **SERIOUS BODILY INJURY OR DEATH COULD OCCUR IF YOU IGNORE THIS WARNING.**

When any maintenance is performed on the water heater or the home's plumbing system that may introduce air into the plumbing pipes, it is important to turn the power off to the water heater and purge the air out of the lines before allowing the unit to power up. **FAILURE TO DO SO COULD CAUSE PERMANENT DAMAGE TO THE HEATING ELEMENT AND VOID YOUR WARRANTY.**

If you have a water supply with a high level of mineralization (hard water), you should increase the frequency of your maintenance.

9- TROUBLE SHOOTING GUIDE

Are you having problems with your water heater?

Please call or email our customer service and technical support team for any help you may need.

TOLL FREE 1-(800) 374-8806

The following table represents some of the most common technical support questions we receive. Before calling us, please read thoroughly to see if your question or problem is addressed.

PROBLEM	POSSIBLE CAUSE	SOLUTION
Water heater is not heating at all (water is flowing but the unit is not heating - the outgoing water temperature is the same as the cold water supply) - the digital display does NOT light up.	No power or incorrect wiring.	Make sure the breakers at main electrical panel are ON. You may have a faulty breaker or unit may be wired incorrectly.
	Flow rate is too low / water pressure is too low.	Your water heater has an activation flow rate of approximately 0.3 GPM (1.1 LPM). If your water flow rate is less than this level, your unit will not activate. Increase the flow rate.
Water heater is not heating at all (water is flowing but the unit is not heating - the outgoing water temperature is the same as the cold water supply) The digital display DOES light up.	Internal part failure.	Please call us for technical assistance.
Water heater is heating, but the water temperature is not hot enough.	User temperature setting too low.	Turn up the temperature setting on the unit.
	Flow rate is too high.	Depending on your incoming water temperature and the kW of your heater, your water flow rate may exceed the physical heating capacity of your water heater. Reduce the flow rate by installing a Flow Regulator. Use the chart in section 6 to find out which flow regulator works best for your particular heater.
	Crossed wires.	If it's a new installation, have your electrician double check the wiring. Is possible that the wiring is incorrect.
	Voltage less than 240 volts.	The heating elements on your water heater are design for 240 volts. When used with a lower voltage, they produce less heating power. You may need to upgrade to a larger input heater.
	Mixing too much cold water.	You do not need to mix as much cold water with your tankless water heater compared to when you use a conventional water heater. You may also have an anti-scald feature on your faucet that is mixing cold water. These types of faucets can usually be adjusted to reduce the amount of cold water mixed.
The water temperature at the faucet is less or greater than the temperature setting of my water heater.	Voltage less than 240 volts.	The computer chips in your tankless water heater are programmed with the expectation that your incoming line voltage is 240 volts. If you have less than 240 volts, it may affect the reading on your water heater's digital display and cause it to read slightly higher than the actual output temperature. To compensate for this, increase the setting on your water heater if you need / want hotter water.
	Anti-Scald pressure/balancing valve or tempering valve.	Your faucet may have an anti-scald feature or a tempering valve that automatically mixes cold water even when you turn your control lever or handle to full hot. These devices are usually adjustable so you can turn off the cold mix completely. You can compensate for this by increasing the setting on your water heater if you need/want hotter water.
	Thermal loss due to long pipe run	As the hot water from the heater runs through the hot water delivery system to your faucet, some heat will be lost especially if it has long distance to travel or the pipes are cold. This is normal. You can compensate for this by increasing the setting on your water heater if you need/want hotter water.
	Water temperature at the faucet is too hot	Check your flow for too little flow, set point temperature is too high, or internal part failure. Call us for technical assistance.

10- USER INTERFACE

Power

- Click adjustment knob, the display will turn on
- Click the adjustment knob again, the display will turn off

C/F Conversion

- Press the adjustment knob for 3 seconds, the display will change from Fahrenheit to Celsius or vice versa

Temperature Control

- Turning the knob clockwise increases the set output water temperature
- Turning the knob counter clockwise decreases the set output water temperature
- You can set or adjust the temperature at any time between 80°F – 140°F (27°C – 60°C). The temperature can be changed to your desired setting. The display will only stay on when the unit is in use or when you are setting the temperature.



DANGER Hotter water increases the potential for Hot Water SCALDS

CAUTION – removing the cover to change the temperature set point exposes electrical shock and burn hazards, which can cause INJURY or DEATH. Adjustment should only be done by a licensed plumber or electrician.

Heater input: 8kW –11kW –13kW

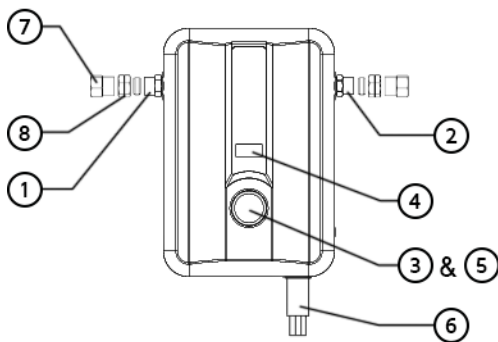

Heater input: 18kW –24kW –27kW –36kW

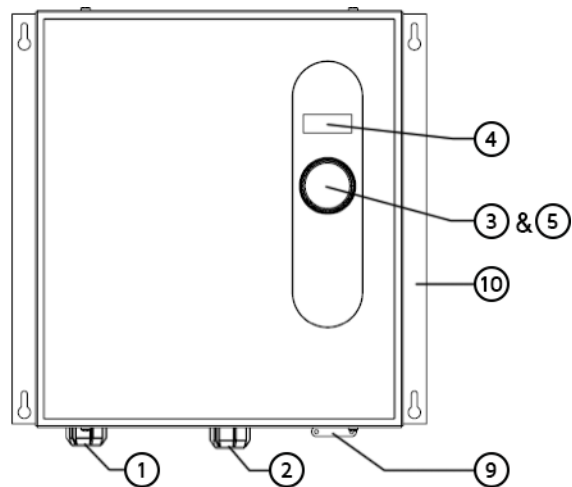

1. Hot Water Outlet

2. Cold Water Inlet

3. Celsius/Fahrenheit Conversion (Press & Hold 3 sec.)

4. Temperature Set Point Display

5. Adjustment Knob & Temperature Control

6. Wire Connection

7. Brass Compression Nut

8. Brass Compression Ferrule

9. Electrical Strain Relief

10. Mounting Bracket (1")

Input	Height in(mm)	Width in(mm)	Depth in(mm)
8/11/13kW	12 (292.1)	9.75 (247.7)	3.75 (95.3)
18kW	18 (431.8)	14 (355.6)	3.75 (95.3)
24/27kW	18 (431.8)	17 (431.8)	3.75 (95.3)
36kW	18 (431.8)	19 (482.6)	3.75 (95.3)

