

INSTALLATION INSTRUCTIONS

Read installation instructions first before installing. Check parts to ensure that no damage has occurred during transit and that no parts are missing. Also check the diameter of the pipe and the range marked on the clamp to ensure you have the proper size.

Style SCC Full Circumferential Repair Clamp

Step 1 • Check the Clamp parts to insure that no damage has occurred during transit and that no parts are missing. Also check the diameter of the pipe and the size marked on the clamp to insure you have the proper size. Thoroughly clean pipe surface that will be covered by the clamp. A suitable gasket lubricant should be used on rough surface pipe to assure proper seal.

Step 2 • Place reference marks on the pipe in line with the crack or hole in the pipe, slightly wider than the clamp.

Step 3 • Wrap gasket cartridge around pipe.

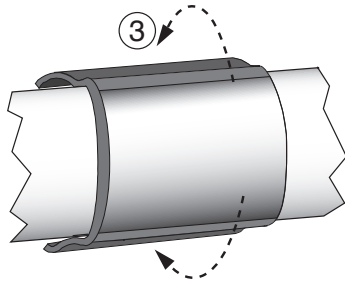

Step 4 • Back off nuts of shell to the end of the bolt, **DO NOT REMOVE**. Separate clamp and wrap it around the gasket cartridge).

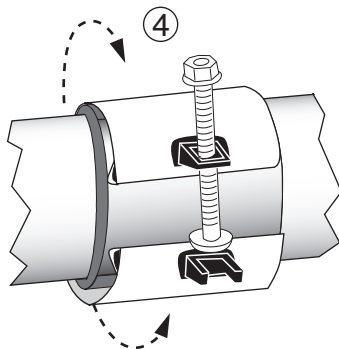

Note: If necessary (because of water pressure) Step 4 and Step 5 can be performed beside the pipe break. Slide the clamp over the break after the bolt head has been snapped in place.

Step 5 • Align the gasket cartridge so that the armor is centered under the gap in the shell. Bring two clamp ends together and snap bolts into place on top of receiver lugs. Make sure the gasket has seated itself flat onto the pipe face. Tighten nuts finger tight. Rotate clamp into position and center the bolts over the crack or hole being repaired (check reference marks).

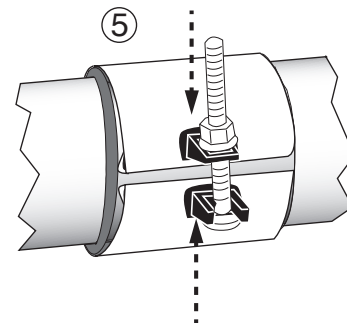

TIP: If bolt head is unable to slide over top of receiver lug, try pulling end of bolt and nut away from clamp shell which will allow bolt head to snap into place.

Step 6 • Tighten all nuts evenly in 10 ft-lb. increments. Keep torques as evenly balanced as possible. Use a wrench with at least a 12" handle.

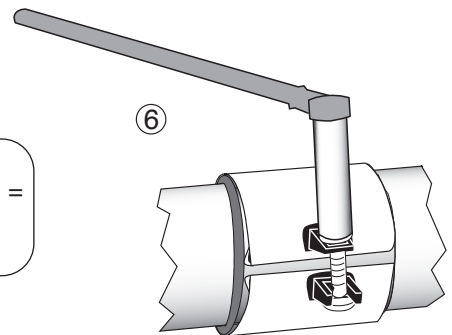

Note:
25 ft-lbs. torque =
12" wrench
w/25 lbs. force

Torque Recommendation
20-25 ft-lbs. Max.

For best results, wait 10 minutes and then re-tighten to proper torque.

Style SCC Full Circumferential Repair Clamp

PRECAUTIONS

1. Check diameter of pipe to make sure you are using the correct size clamp.
2. Clean pipe to remove dirt and corrosion from the surface.
3. Place marks on the pipe to reference the leak. Use these marks to assure that the clamp is properly positioned.
4. Make sure no foreign materials stick to the gasket as it is brought around the pipe, nor become lodged between gasket and pipe as nuts are tightened.
5. Avoid loose fitting wrenches, or wrenches too short to achieve proper torque.
6. Keep threads free of foreign material to facilitate tightening.
7. Bolts are often not tightened enough when a torque wrench is not used. Take extra care in this situation to make sure proper tightening occurs. Do not exceed 25-ft-lbs.
8. Pressure test for leaks before backfilling.
9. Backfill and compact carefully around clamp.
10. When reinstalling parts with stainless steel hardware there may be a loss in pressure holding ability due to worn or damaged threads during the original installation.

COMMON INSTALLATION PROBLEMS

1. Bolts are not tightened to the proper torque.
2. Bolt torque is in excess of 25 ft-lbs.
3. Rocks or debris between pipe and gasket.
4. Dirt on threads of bolts or nuts.
5. Repair clamp too small for the size of damage to pipe.
6. Repair clamp not centered over damaged portion of pipe.
7. Repair clamps should not be used as couplings.