

DURCOR[®]

ADVANCED COMPOSITE
PTFE LINED PIPING SYSTEM



PureFlex[®]
an ANDRONACO INDUSTRIES company

Innovation is in our DNA

PureFlex is a world leading manufacturer of high performance Fluoropolymer and Composite products and technologies. We specialize in the manufacturing of fluid handling and sealing products specifically designed for chemical, pharmaceutical and ultrapure related industries.

Since 1994, we have earned a reputation for creating fluid handling and sealing products that are truly different. We create innovations; products that serve demanding applications better than before. PureFlex excels in its service, aggressive in its technology, bold in vision, and responsible in its regard for safe and dependable products.



100,000 sq. feet
DURCOR Manufacturing



200,000 sq. feet
Corporate Offices & Manufacturing

ANDRONACO INDUSTRIES is a group of global manufacturing companies specializing in innovative engineered products, specialty systems, and value added services for the pharmaceutical, chemical, steel, waste water, mining and energy markets. We support autonomous operating companies focused on meeting the demands of their customers requirements in ultrapure and industrial fluid management. Our companies pride themselves on exhibiting the highest ethical, moral and legal standards in the conduct of its business.



**SCIENCE FICTION THINKING
ZERO CORROSION REALITY**

Durcor® is the world's first advanced structural composite piping system designed exclusively to be lined with seamless PTFE. Durcor's architecture was optimized from the start, not compromised by conversion. It is the strongest, lightest, most chemically resistant piping system available.

Durcor's thick wall PTFE liner provides unmatched internal chemical resistance while its revolutionary vinyl ester / fiberglass housing provides outstanding exterior corrosion protection, high impact resistance and excellent span and burst capabilities. The construction of Durcor offers the ultimate in corrosion resistance and carries the industry's first (5) year bumper to bumper warranty.



Strong, Light Weight, Zero Corrosion



**End Corrosion Attack
with
Durcor®**

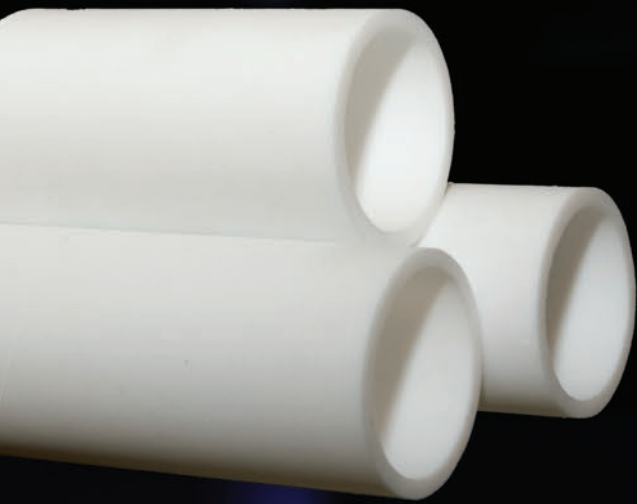

PTFE MAXIMUM CHEMICAL RESISTANCE

Without question, PTFE (polytetrafluoroethylene) offers the broadest capabilities of any commercially available material. In Durcor pipe, PTFE will handle temperatures up to 300°F and resist:

- all acids and all solvents
- all organic and inorganic chlorides & sulfates
- all bleach solutions
- all phenols and all caustics
- all peroxides

as well as any combination of the above. PTFE also has incredible non-stick properties which eliminate and/or minimize deposits on pipe wall.

Durcor's seamless PTFE liners exceed the requirements of ASTM F1545 where applicable. Liner thickness range from .130" for 1" pipe to .310" for 8" diameter piping. Durcor's thick and strong liners aid in permeation resistance and are able to withstand full vacuum conditions throughout its full temperature range.

Typical Properties of Durcor PTFE Liner			
Property	Test Method	Unit	Value
Tensile Strength	ASTM D638	psi	3,000
Ultimate Elongation	ASTM D638	%	250
Izod Impact Strength @ (-)40°F	ASTM D256	ft-lb/in	1.5
Izod Impact Strength @ (-)75°F	ASTM D256	ft-lb/in	3
Hardness, Durometer	ASTM D2240	Shore D	55
Thermal Conductivity	ASTM E1530	Btu/hr-ft ² -F	0.14
Dielectric Strength	ASTM D149	V/mil	600
Surface Resistivity	ASTM D257	ohm-sq.	>10 ¹⁵
Water Absorption	ASTM D570	%	<0.01
UL 94 Flame Rating			94 V-0
Static Coefficient of Friction			0.05
Specific Gravity			2.14 - 2.19

THERMOSIZED™ PTFE LINERS

Durcor's thick, free standing PTFE liners undergo a battery of tests designed to ensure liner integrity prior to being positioned into its structural composite housing. Durcor's unique Thermosizing process combines the PTFE liner into the composite pipe. An additional heating cycle then relaxes the liner for a snug, interference fit within the composite housing. The Thermosize technique provides PTFE dimensional stability under pressure, vacuum and temperature cycling conditions.

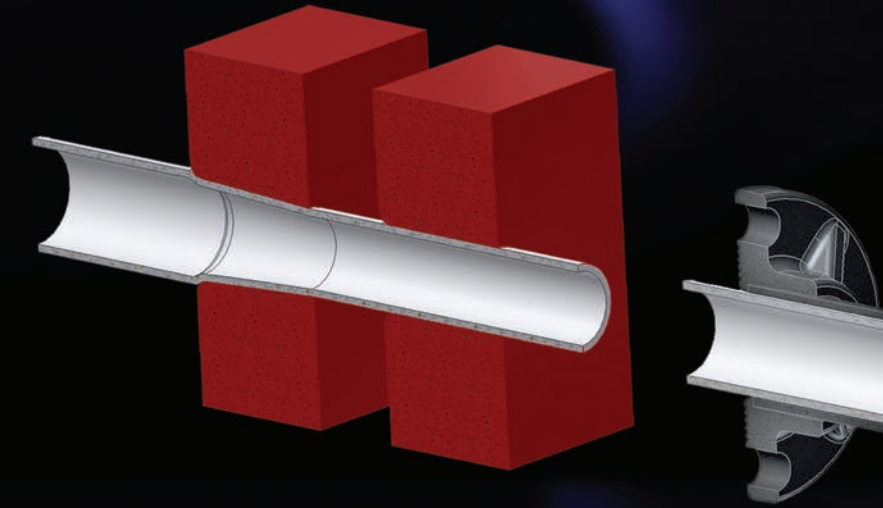

- ZERO CORROSION RATE
- Size range 1" to 8"
- Full vacuum rated
- Pressures to 275 psi
- Temperature ratings Uninsulated (-)40°F to (+)300°F

- Superior strength to weight ratio
- 1/4 the weight of steel
- Lower freight cost
- Lower installed cost
- Faster to install
- Safer to install
- No exterior priming or painting required



ADVANCED STRUCTURAL COMPOSITE HOUSING

Durcor is the world's first composite pipe designed exclusively to support free-standing PTFE fluoropolymer liners. Through a proprietary process, Durcor pipe is manufactured with glass fiber bundles, pressure saturated with a highly chemical resistant formulation of premium vinyl ester resin to provide maximum exterior protection. The fiberglass bundles are oriented in strict axial and hoop routes which provide outstanding impact, stiffness and pressure capabilities. Durcor is dimensionally equivalent to schedule 40 steel pipe and can be essentially treated the same. Durcor also has excellent insulating properties and can often eliminate the need for tracing and/or reduced thickness of insulation required to maintain a given temperature.

Typical Properties of Durcor®				
Property	75°F	250°F	Typical FRP @ 75°F	Method
Axial Tensile Strength	48,000 psi	31,200 psi	11,600 psi	ASTM D2105
Axial Tensile Design Strength	12,000 psi	7,800 psi	3,870 psi	
Axial Modulus of Elasticity	2.76 X 10 ⁶ psi	1.70 X 10 ⁶ psi	1.6 X 10 ⁶ psi	
Axial Compression Strength	50,750 psi	34,075 psi	14,500 psi	ASTM D695
Axial Compression Design Strength	12,690 psi	8,520 psi		
Compression Modulus	2.39 X 10 ⁶ psi	1.47 X 10 ⁶ psi		
Beam Bending Ultimate Stress	47,100 psi	35,300 psi	12,380 psi	ASTM D2935
Beam Bending Design Stress	5,900 psi	4,410 psi		
Poisson's Ratio	0.32		0.65	
Flexural Modulus of Elasticity	3.26 X 10 ⁶ psi	1.89 X 10 ⁶ psi	1.81 X 10 ⁶ psi	ASTM D790
Coefficient of Linear Thermal Expansion	4.5 X 10 ⁻⁶ in/in/°F		10 X 10 ⁻⁶ in/in/°F	
Specific Gravity	1.92 (housing) and 2.15 (PTFE)		1.80	
Heat Deflection Temperature	266°F			
Hazen-Williams Flow Coefficient	155		150	
Thermal Conductivity	0.22 Btu/hr-ft ² -°F			

Resin-rich outer layer provides corrosion and abrasion barrier. The barrier surface provides excellent chemical resistance from hostile environments and corrosive soils that can attack carbon steel. The additional layers add protection against glass blooming caused by ultraviolet radiation from sunlight.

Axial glass roving filament bundles in linear direction provide exceptional stiffness and better span capabilities with near-zero thermal expansion.

Continuous bundles of reinforcing glass roving are wrapped radially over inner veil to provide outstanding hoop strength for 4:1 pressure safety factor.

Multiple inner layers of resin-rich veil provide superb corrosion barrier to reinforcing roving bundles.

PTFE liner thickness exceeds the requirements of ASTM F1545 and is full vacuum rated in all sizes to +300°F.

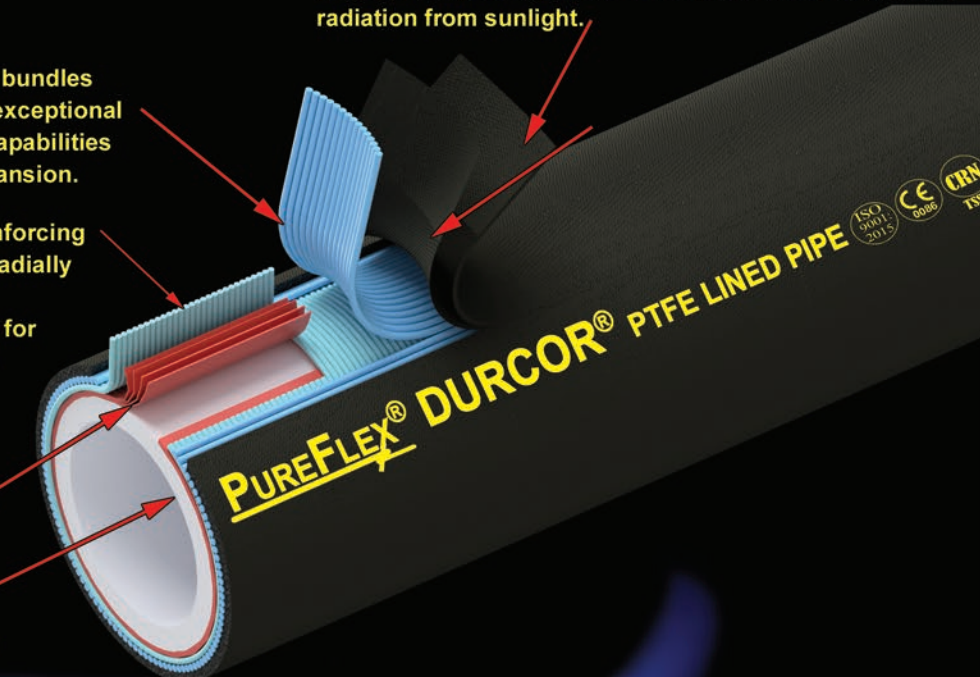

Durcor® Outstanding Dimensional Control and Tolerance

ETHYLENE™ PTFE

an ANDRONACO INDUSTRIES company

For over 50 years, Ethylene has been a recognized leader in the design and manufacturing of advanced PTFE lined products. Durcor utilizes that experience in its PTFE fitting liners. All Ethylene liners are seamless, isostatically molded and independent of the Durcor composite housing. The process enables all liners to be tightly controlled for conformity to dimensional requirements and leak-free performance. The thick wall PTFE liners incorporate exclusive radial locking ribs for maintaining dimensional stability during temperature cycling. All Ethylene / Durcor fitting liners are rated for full vacuum to 300 °F.

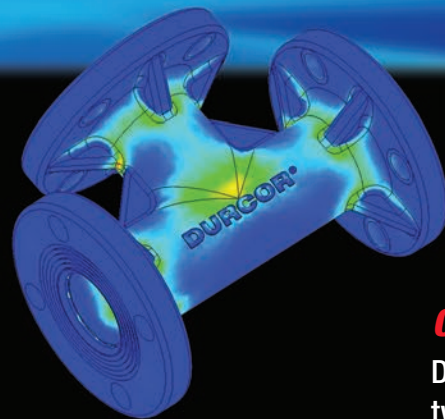

Red reveals weakness in standard FRP fitting

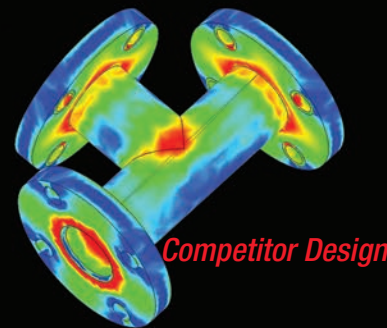

Competitor Design



CONSISTENCY

Durcor fittings are manufactured in two part closed molds, resin injection completely wetting out all fibers. Speed and pressures remain consistent producing a uniform product thickness that is void free, has smooth surfaces and all parts are identical to one another. Durcor's manufacturing process also offers health & safety, and environmental control due to enclosed resin injection which releases less volatiles into the atmosphere and less exposure to employees during manufacturing.

Optimized NOT Compromised

TRACEABILITY

Durcor PTFE lined fittings are the industry's first to incorporate a date stamp showing month and year of manufacture for lot traceability. All Durcor pipe and fittings have an unlimited shelf life.



DURCOR PIPING SYSTEM IS NOT A DUAL LAMINATE

Durcor piping system should not be confused with dual laminate. Unlike dual laminate fittings & pipe, Durcor has excellent dimensional control and tolerance as well as outstanding surface quality. Durcor utilizes thick, seamless PTFE liners that don't require any chemical or mechanical bonding to composite that could lead to delamination failure. Dual laminate liners typically are made from sheet that is rolled and welded to form geometrical shapes. The nature of hand lay-up dual laminate process results in parts with inconsistent fiber orientations and resin wet-out. Resin is applied over glass with rollers and excess is removed with squeegees, the process is highly reliant on operator skill.

The process typically generates a textured finish on inner surfaces which provide a poor condition for bonding between added layers. The resins need to be low viscosity to be workable by hand, which compromises their mechanical / thermal properties due to the need for high diluents / styrene levels. Porous voids are common in hand lay-up parts and tight dimensional accuracy & smooth surfaces are impossible. Lastly, this technique raises environmental & safety concerns with the amount of volatiles it generates and releases into the atmosphere due to rollers and squeegees being used to apply resin. Contact molding is also another term used for hand lay-up.

Durcor fittings are typically 1/4 the weight of alloy PTFE lined fittings.

- Lower Freight Costs
- Lower Installation Costs
- Quicker to Install
- Safer to Install

Components of Durcor's product line are manufactured to established dimensional standards, making them completely interchangeable with other PTFE alloy piping manufacturers.

All PTFE lined products are susceptible to vapor permeation by certain chemicals under certain operating conditions. Through osmosis, Durcor fittings allow any gas to freely vent without the need for vent holes.

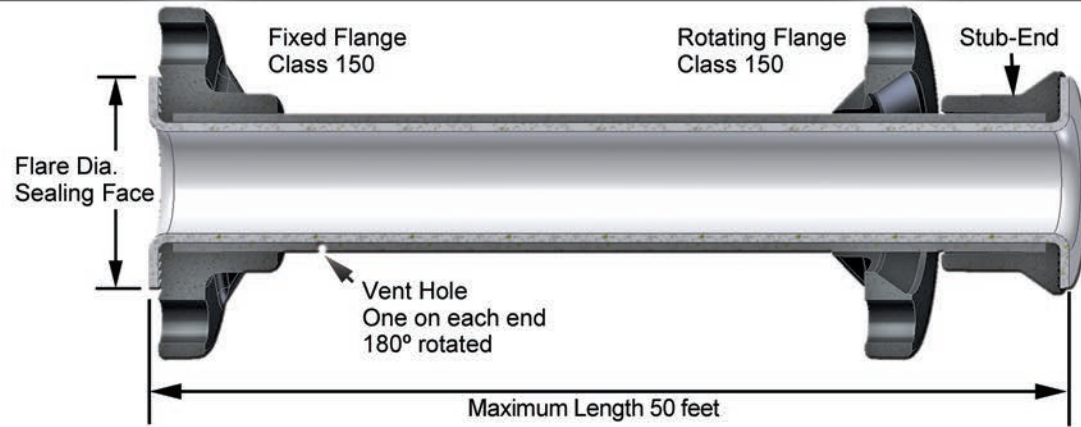

We have included some basic design data to determine if Durcor piping system meets your principle requirements. For more engineering data on expansion, end loads from restrained thermal expansion, minimum offset leg requirements, etc., please refer to Durcor Piping Design & Specification Guide, brochure Eng-2100.

Size (in)	ID PTFE Pipe (in)	Flare Dia. (in)	Liner Thickness (in)	Pipe OD (in)	Dry wt/ft (lbs/ft)	Capacity (gal/ft)
1	0.79	2.00	0.130	3.36	0.83	0.03
1 1/2	1.34	2.88	0.150	3.80	1.29	0.07
2	1.74	3.63	0.160	4.10	1.75	0.12
3	2.75	5.00	0.160	4.10	3.14	0.31
4	3.71	6.19	0.175	4.40	4.37	0.56
6	5.50	8.50	0.280	7.10	9.14	1.23
8	7.36	10.63	0.310	7.90	13.56	2.21

Size (in)	Uninsulated Pipe		
	Up to 150°F	225°F	300°F
1	14	13	12.5
1 1/2	16.5	15	14.5
2	18	16.5	15.5
3	22	20	19
4	24	22	21
6	27.5	25	24.5
8	34	28	27

Temperature Change (°F)	Durcor (in/100 FT)	Fiberglass (in/100 FT)	PVC (in/100 FT)	CPVC (in/100 FT)	Carbon Steel (in/100 FT)	Stainless Steel (in/100 FT)
25	0.14	0.30	0.90	1.14	0.19	0.26
50	0.27	0.60	1.80	2.28	0.38	0.51
75	0.41	0.90	2.70	3.42	0.58	0.77
100	0.54	1.20	3.60	4.56	0.77	1.02
125	0.68	1.50	4.50	5.70	0.96	1.28
150	0.81	1.80	5.40	6.84	1.15	1.53
175	0.95	2.10	6.30	7.98	1.34	1.79
200	1.08	2.40	7.20	9.12	1.54	2.04

*Note: For water filled pipe. These values consider maximum 0.5" mid-span deflection. These values do not take into account concentrated loads from flanges.

Nominal Pipe Size (in)	Max. Pressure @ (-)40°F (psi)	Max. Pressure @ 75°F (psi)	Max. Pressure @ 300°F (psi)
1	275	275	230
1 1/2	275	275	230
2	275	275	230
3	225	225	175
4	200	200	150
6	175	175	125
8	150	150	100

Size (in)	Length (ft)
1 - 8	20
1 - 4	50

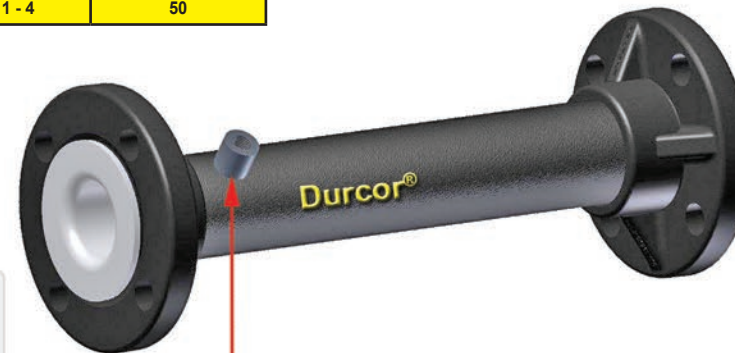

Special vent couplings are available for pipe with insulation. 1/8" NPS half couplings can be supplied and pipe nipples of sufficient length can extend through the insulation cover.

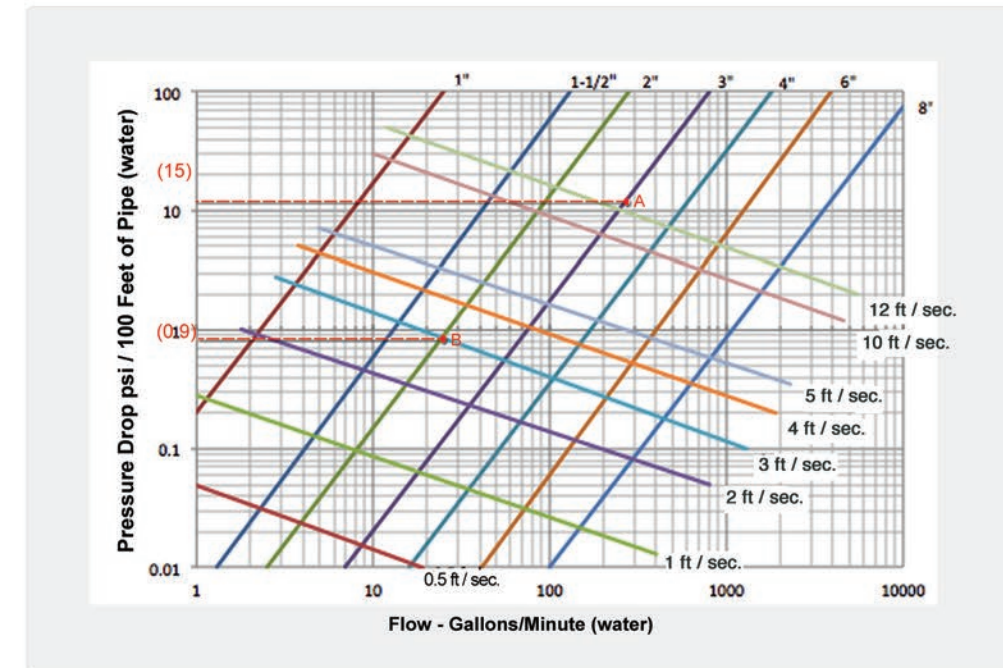
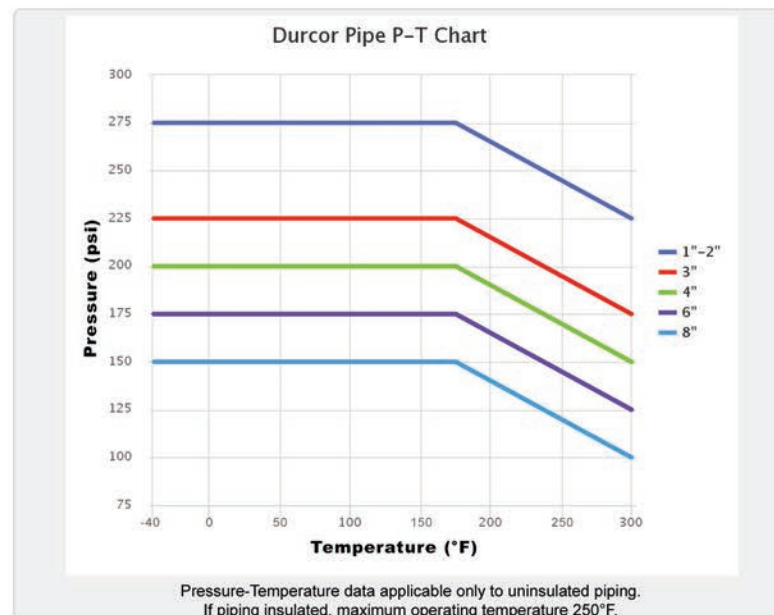

All Durcor flanges (pipe & fittings) have a ribbed face to aid against cold flow (creep) or flare distortion during temperature cycling.



Standard flange drilling is Class 150
DIN PN10/PN16, JIS B2220 5KG/10KG also Available

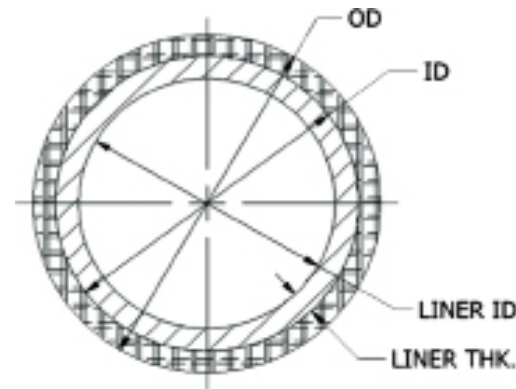

Durcor® Pipe

Size (in)	ID PTFE Pipe (in)	Liner Thickness (in)	Pipe OD (in)	Durcor® Weight (lbs)	Steel Lined (lbs)
1	0.79	0.130	1.36	0.83	2.1
1 1/2	1.34	0.150	1.92	1.29	3.4
2	1.74	0.160	2.38	1.75	4.6
3	2.75	0.160	3.50	3.14	9.1
4	3.71	0.220	4.50	4.37	13.0
6	5.50	0.280	6.63	9.14	22.8
8	7.36	0.310	8.63	13.56	32.1



Min. Spool

Size (in)	Minimum Spool Length "L" (in)
1	3-1/4
1 1/2	3-1/2
2	4-1/2
3	4-1/2
4	5
6	7-1/4
8	7-3/8

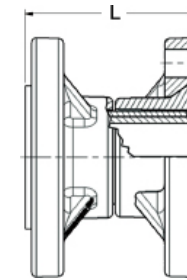

Distance Pieces are used when you need more length than a spacer but don't want the bulk of flanges.

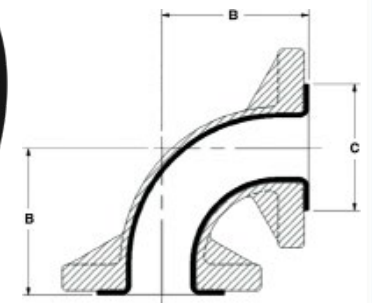
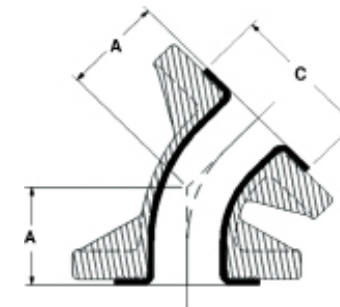
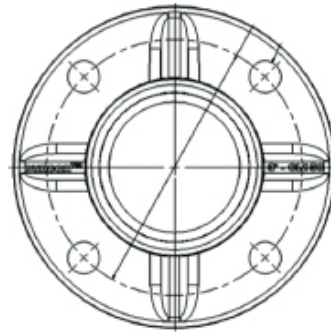
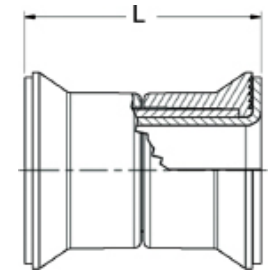

Flanges - Fixed & Rotating

Size (in)	Outside Dia. (in)	T (Nominal)	H (in)	F (in)	# Holes	Hole Dia.	Durcor® Wt. (lbs)	Ductile Iron Wt. (lbs)
1	4.25	.78	1-7/16	2-9/32	4	.63	0.7	2.0
1 1/2	5.00	.87	1-5/8	3	4	.63	1.0	3.0
2	6.00	.90	2-1/8	3-13/16	4	.75	1.6	4.7
3	7.50	1.18	2-3/16	5-1/8	4	.75	2.8	9.2
4	9.00	1.16	2-3/8	6-5/16	8	.75	3.6	12.4
6	11.00	1.19	3	8-1/2	8	.88	4.6	16.8
8	13.50	1.38	3	10-5/8	8	.88	7.8	28.0

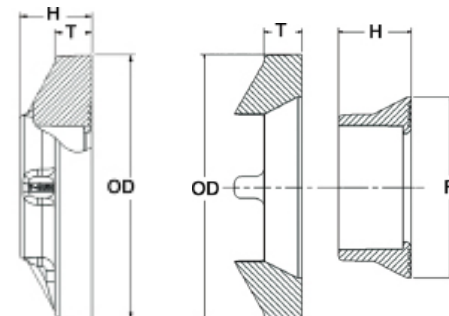

45° Elbow

Size (in)	Dimensional Data		Compare Weights	
	A (in)	C (in)	Durcor® Weight (lbs)	Alloy Fitting (lbs)
1	1-3/4	2	1.3	5.5
1 1/2	2-1/4	2-7/8	2.1	8
2	2-1/2	3-5/8	3.1	11
3	3	5	6.4	22
4	4	6-3/16	10.2	39.5
6	5	8-1/2	16.7	63.0
8	5-1/2	10-5/8	28.1	110.0

90° Elbow

Size (in)	Dimensional Data		Compare Weights	
	B (in)	C (in)	Durcor® Weight (lbs)	Alloy Fitting (lbs)
1	3-1/2	2	1.5	6
1 1/2	4	2-7/8	2.4	9
2	4-1/2	3-5/8	3.5	14.0
3	5-1/2	5	7.7	26.0
4	6-1/2	6-3/16	10.6	41.0
6	8	8-1/2	19.5	75.0
8	9	10-5/8	32.9	125.0

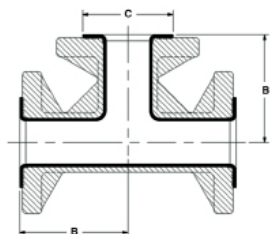

Standard Tee

Dimensional Data			Compare Weights	
Size	B (in)	C (in)	Durcor® Weight (lbs)	Alloy Fitting Weight (lbs)
1	3-1/2	2	2.6	10.0
1-1/2	4	2-7/8	3.7	14.0
2	4-1/2	3-5/8	5.4	20.5
3	5-1/2	5	12.0	40.0
4	6-1/2	6-3/16	17.0	67.0
6	8	8-1/2	29.3	120.0
8	9	10-5/8	45.6	180.0

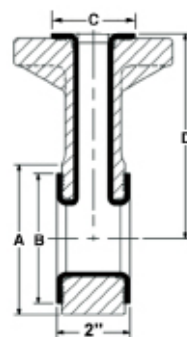

Instrument Tee

Dimensional Data				Compare Weights		
Size	A (in)	B (in)	C (in)	D (in)	Durcor® Weight (lbs)	Alloy Fitting Weight (lbs)
1 x 1	2-5/8	2	2	3-1/2	1.4	3.7
1-1/2 x 1	3-3/8	2-7/8	2	4	1.8	5.1
2 x 1	4-1/8	3-5/8	2	4-1/2	2.3	6.6
3 x 1	5-3/8	5	2	5-1/2	3.1	9.2
4 x 1	6-7/8	6-3/16	2	6-1/2	4.2	13.3
6 x 1	8-3/4	8-1/2	2	8-1/16	5.4	17.4
8 x 1	11	10-5/8	2	9	7.2	27.6

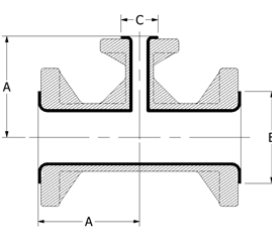

Reducing Tee

Dimensional Data			Compare Weights		
Size	A (in)	B (in)	C (in)	Durcor® Weight (lbs)	Alloy Fitting Weight (lbs)
1-1/2 x 1	4	2-7/8	2	3.5	12.2
2 x 1	4-1/2	3-5/8	2	4.6	16.2
2 x 1-1/2	4-1/2	3-5/8	2-7/8	5.0	17.6
3 x 1	5-1/2	5	2	8.4	31.0
3 x 1-1/2	5-1/2	5	2-7/8	8.9	32.2
3 x 2	5-1/2	5	3-5/8	9.7	34.0
4 x 1	6-1/2	6-3/16	2	12.1	44.6
4 x 1-1/2	6-1/2	6-3/16	2-7/8	12.6	56.2
4 x 2	6-1/2	6-3/16	3-5/8	13.0	57.0
4 x 3	6-1/2	6-3/16	5	14.5	57.7
6 x 2	8	8-1/2	3-5/8	22.4	90.8
6 x 3	8	8-1/2	5	24.0	104.5
6 x 4	8	8-1/2	6-3/16	25.1	105.6
8 x 3	9	10-5/8	5	36.9	138.6
8 x 4	9	10-5/8	6-3/16	38.1	165.5
8 x 6	9	10-5/8	8-1/2	40.4	170.3

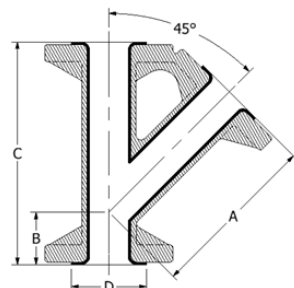

45° Lateral

Dimensional Data				Compare Weights		
Size	A (in)	B (in)	C (in)	D (in)	Durcor® Weight (lbs)	Alloy Fitting Weight (lbs)
1	5-3/4	1-3/4	7-1/2	2	2.6	12
1-1/2	7	2	9	2-7/8	4.4	18
2	8	2-1/2	10-1/2	3-5/8	6.2	25
3	10	3	13	5	12.5	53
4	12	3	15	6-3/16	17.8	97
6	14-1/2	3-1/2	18	8-1/2	36.3	145
8	17-1/2	4-1/2	22	10-5/8	57.3	219

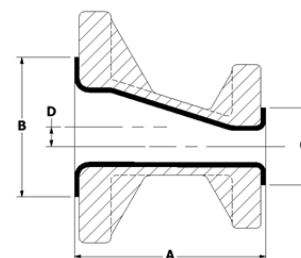

Eccentric Reducer

Dimensional Data				Compare Weights		
Size	A (in)	B (in)	C (in)	D (in)	Durcor® Weight (lbs)	Alloy Fitting Weight (lbs)
1-1/2 x 1	4-1/2	2-7/8	2	1/4	1.7	6.7
2 x 1	5	3-5/8	2	1/2	2.3	8.9
2 x 1-1/2	5	3-5/8	2-7/8	1/4	2.7	10.4
3 x 1-1/2	6	5	2-7/8	3/4	4.0	15.3
3 x 2	6	5	3-5/8	1/2	4.6	17.7
4 x 1-1/2	7	6-3/16	2-7/8	1-1/4	5.8	22.3
4 x 2	7	6-3/16	3-5/8	1	6.4	24.6
4 x 3	7	6-3/16	5	1/2	7.5	29.0
6 x 3	9	8-1/2	5	1-1/2	11.6	44.5
6 x 4	9	8-1/2	6-3/16	1	13.4	51.5
8 x 4	11	10-5/8	6-3/16	2	20.0	75.5
8 x 6	11	10-5/8	8-1/2	1	23.1	84.0

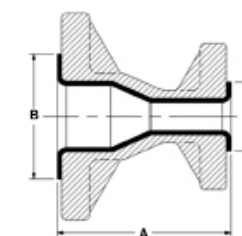

Concentric Reducer

Dimensional Data			Compare Weights		
Size	A (in)	B (in)	C (in)	Durcor® Weight (lbs)	Alloy Fitting Weight (lbs)
1-1/2 x 1	4-1/2	2-7/8	2	1.7	6.7
2 x 1	5	3-5/8	2	2.3	8.9
2 x 1-1/2	5	3-5/8	2-7/8	2.7	10.4
3 x 1	6	5	2	3.5	13.5
3 x 1-1/2	6	5	2-7/8	4.0	15.3
3 x 2	6	5	3-5/8	4.6	17.7
4 x 1	7	6-3/16	2	5.3	20.4
4 x 1-1/2	7	6-3/16	2-7/8	5.8	22.3
4 x 2	7	6-3/16	3-5/8	6.4	24.6
4 x 3	7	6-3/16	5	7.5	29.0
6 x 2	9	8-1/2	3-5/8	10.5	40.3
6 x 3	9	8-1/2	5	11.6	44.5
6 x 4	9	8-1/2	6-3/16	13.4	51.5
8 x 4	11	10-5/8	6-3/16	20.0	75.5
8 x 6	11	10-5/8	8-1/2	23.1	84.0

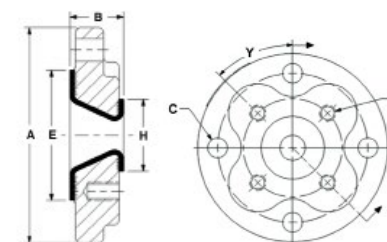

Reducing Flange

Dimensional Data				C Holes		D Holes				Compare Weights				
Size	A (in)	B (in)	E (in)	H (in)	# Holes	Dia.	B.C.	# Holes	Thread	B.C.	Depth	Y°	Durcor® Weight (lbs)	Alloy Fitting Weight (lbs)
1-1/2 x 1	5	1-9/16	2-7/8	2	4	5/8	3-7/8	4	1/2-13	3-1/8	1	45	1.2	4.3
2 x 1	6	1-9/16	3-5/8	2	4	3/4	4-3/4	4	1/2-13	3-1/8	1	45	1.8	6.0
2 x 1-1/2	6	1-9/16	3-5/8	2-7/8	4	3/4	4-3/4	4	1/2-13	3-7/8	1	45	1.8	6.3
3 x 1	7-1/2	1-5/8	5	2	4	3/4	6	4	1/2-13	3-1/8	3/4	45	3.0	11.5
3 x 1-1/2	7-1/2	1-5/8	5	2-7/8	4	3/4	6	4	1/2-13	3-7/8	1	45	3.0	12.8
3 x 2	7-1/2	1-3/4	5	3-5/8	4	3/4	6	4	5/8-11	4-3/4	1-1/4	45	3.4	12.5
4 x 1	9	1-7/8	6-3/16	2	8	3/4	7-1/2	4	1/2-13	3-1/8	3/4	0	4.7	15.8
4 x 1-1/2	9	1 7/8	6-3/16	2-7/8	8	3/4	7-1/2	4	1/2-13	3-7/8	3/4	0	3.9	15.5
4 x 2	9	2	6-3/16	3-5/8	8	3/4	7-1/2	4	5/8-11	4-3/4	15/16	0	5.5	14.5
4 x 3	9	1-3/4	6-3/16	5	8	3/4	7-1/2	4	5/8-11	6	15/16	0	4.4	14.5
6 x 1-1/2	11	2 1/4	8-1/2	2 7/8	8	7/8	9-1/2	4	1/2-13	3-7/8	3/4	0	6.2	24.5
6 x 2	11	2 3/8	8-1/2	3-5/8	8	7/8	9-1/2	4	5/8-11	4-3/4	15/16	0	6.4	24.3
6 x 3	11	2 1/8	8-1/2	5	8	7/8	9-1/2	4	5/8-11	6	15/16	0	6.5	22.3
6 x 4	11	2-1/4	8-1/2	6-3/16	8	7/8	9-1/2	8	5/8-11	7-1/2	15/16	22.5	8.3	22.0
8 x 4	13-1/2	2 1/4	10-5/8	6-3/16	8	7/8	11-3/4	8	5/8-11	7-1/2	15/16	22.5	11.8	39.5
8 x 6	13-1/2	2 1/2	10-5/8	8-1/2	8	7/8	11-3/4	8	3/4-10	9-1/2	1-1/8	22.5	10.8	36.3

Durcor® Blind Flange - Class 150 Lined with PTFE

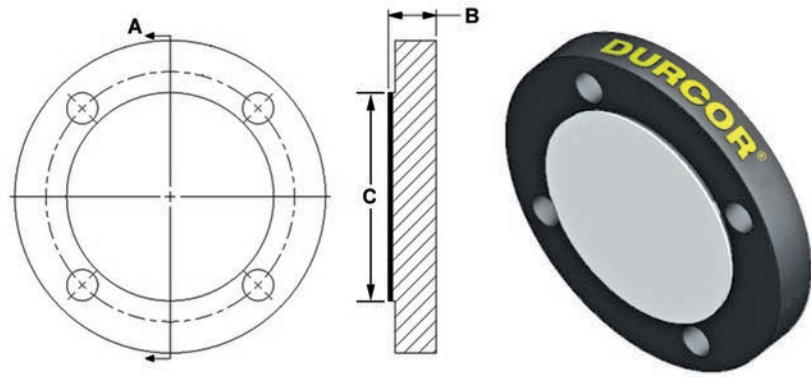

Blind Flange

Size (in)	Dimensional Data			Compare Weights	
	A (in)	B (in)	C (in)	Durcor® Weight (lbs)	Alloy Fitting (lbs)
1	4.25	0.79	2.00	0.7	2.2
1 1/2	5.00	0.86	2.88	1.1	3.3
2	6.00	0.96	3.63	1.7	4.8
3	7.50	1.16	5.00	3.3	9.9
4	9.00	1.16	6.18	4.7	12.8
6	11.00	1.26	8.50	7.7	28.5
8	13.50	1.37	10.63	12.6	47.0

Insulation and Heat Tracing

Insulation and heat tracing are not only used to prevent freezing of the process fluid, but can be used to minimize energy losses and reduce viscosity. The thermal conductivity of Durcor is extremely low, especially when compared to steel lined pipe.

Durcor® - 0.22 BTU/hr-ft-°F

Steel - 34 BTU/hr-ft-°F

Analysis of this feature can often eliminate the need for tracing and / or reduce the thickness of insulation required to maintain a given temperature. On long tracing runs, Durcor flanged Flexijoints® should be provided to compensate for any pipe expansion or contraction.

Maximum Heat Tracing Temperature	
Max Temp.	Type of Tracing
250°F	Hot Water
	Electric
	Steam

Durcor® pipe and fittings should never exceed maximum temperature of 250 °F when insulated.

All typical heat tracing methods may be applied to Durcor pipe and fittings. Consultation with tracing manufactures is highly recommended.

Hot water: Typically the most economical, however, heat transfer cement should be installed for better heat transfer according to cement manufactures' recommendations.

Electrical tracing: Tracing Durcor pipe can be accomplished successfully with electrical cable and sensors to ensure against localized overheating. Specifying a T-Rating that won't allow electrical cable to go above the 250°F is also another option.

Steam tracing: Steam pressure must be controlled so that the temperature does not exceed the maximum temperatures of 250°F. Isolated (insulated) steam tracer should be used to avoid localized overheating.

Because of its extremely low thermal conductivity, it isn't necessary or recommended to insulate the flange connections.

Heating Cable Illustration

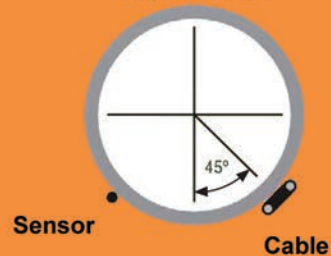

Steam Tracing Illustration

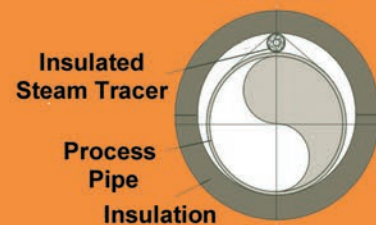

Accessories

Like No Other - Strong, Lightweight, Zero Corrosion

Durcor® Flanged, Ethylene™ Flexijoint® PTFE Expansion joints. The severe service standard. 1/2" to 42" diameter, 2 - 12 convolutions for maximum movement.

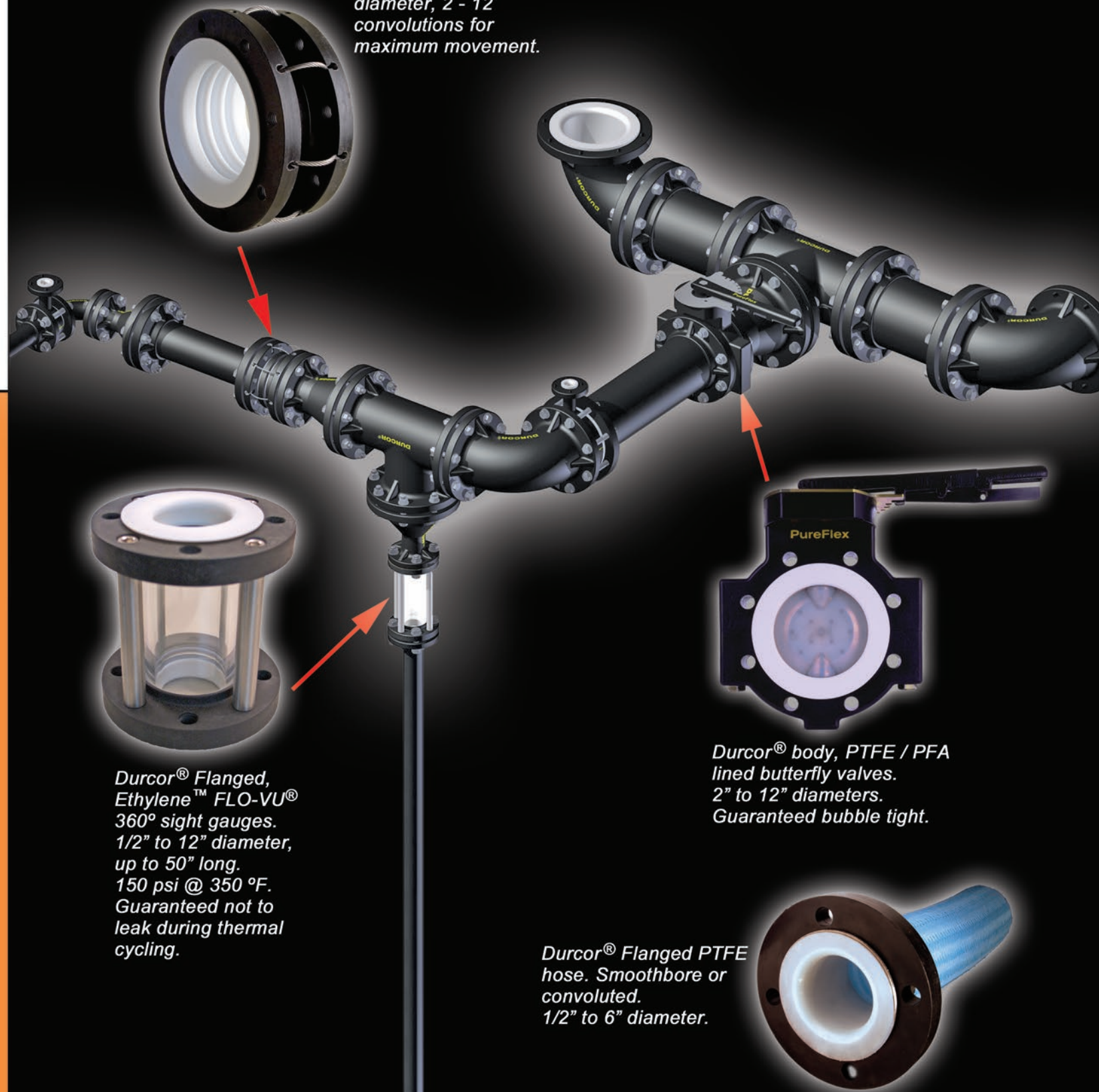

Durcor® Flanged, Ethylene™ FLO-VU® 360° sight gauges. 1/2" to 12" diameter, up to 50" long. 150 psi @ 350 °F. Guaranteed not to leak during thermal cycling.

Durcor® body, PTFE / PFA lined butterfly valves. 2" to 12" diameters. Guaranteed bubble tight.

Durcor® Flanged PTFE hose. Smoothbore or convoluted. 1/2" to 6" diameter.

Durcor® How To Order

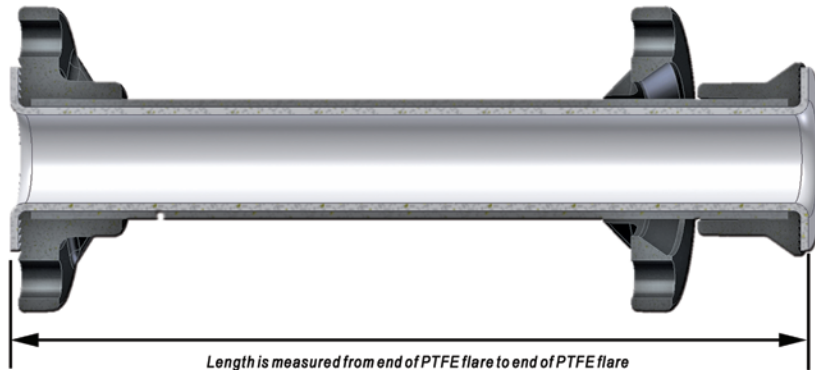

Length is measured from end of PTFE flare to end of PTFE flare
Maximum Length is 600 inches (50 feet)

Example: 2" diameter Durcor® pipe spool, Fixed Flange one end x Rotating Flange other end, 36-1/8" long with no options

Example Part Number : DBP - PT - 032 - RF - 0361

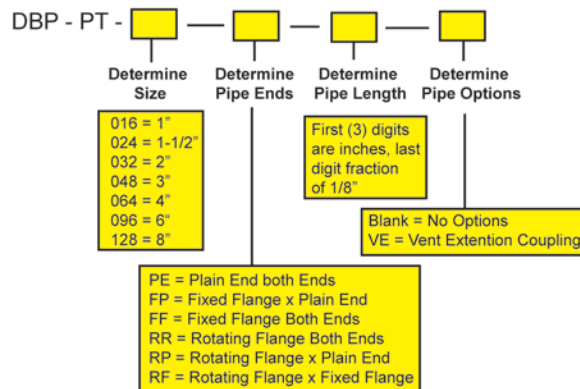

How to Order Fittings

Example: 2" x 1" Reducing Flange

Example Part Number : DBF - PT - 44 - 032 - 016

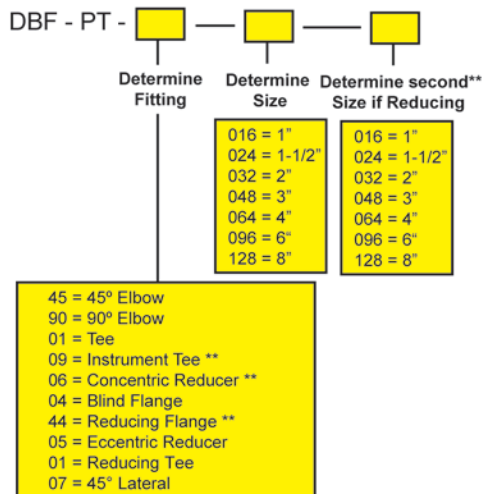

How to Order Flanges

Example: 2" Rotating Flange with Stub-End

Example Part Number : DBF - 10 - 032

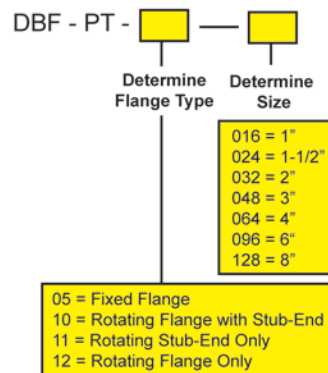

PUREFLEX® INC. INFORMATION IS BASED ON TECHNICAL DATA AND TESTING THAT PUREFLEX® INC. BELIEVES TO BE RELIABLE AND IS SUBJECT TO CHANGE WITHOUT NOTICE. THE INFORMATION IS INTENDED FOR USE BY PERSONS HAVING TECHNICAL SKILL, AT THEIR OWN DESCRIPTION AND RISK. SINCE CONDITIONS OF PRODUCT ARE OUTSIDE OF PUREFLEX® INC. CONTROL, PUREFLEX® INC. MAKES NO WARRANTIES, EXPRESS OR IMPLIED, AND ASSUMES NO LIABILITY IN CONNECTION WITH ANY USE OF THIS INFORMATION. DURCOR® IS A REGISTERED TRADEMARK OF PUREFLEX® INC. FLEXJOINT® IS A REGISTERED TRADEMARK OF ETHYLENE, LLC.

PureFlex®
Inc.

an ANDRONACO INDUSTRIES company

4855 Broadmoor Ave
Kentwood, MI. 49512

Ph 616.554-1100 Fax 616.554-3633

www.PureFlex.com

Durcor 1205-10212020