



Specifications

NR111 SERIES

Up to 11.1 Gal./min.
Indoor & Outdoor Install



NR98 SERIES

Up to 9.8 Gal./min.
Indoor & Outdoor Install



NR83 SERIES

Up to 8.3 Gal./min.
Indoor Install



Gas Consumption (Natural Gas/Propane)	SV: 250,000 - 11,000 BTUH OD: 250,000 - 11,000 BTUH DV: 250,000 - 11,000 BTUH	SV: 199,900 - 12,000 BTUH OD: 199,900 - 12,000 BTUH DVC: 199,900 - 11,000 BTUH	180,000 - 18,000 BTUH
Gas Supply Pressure	SV: NG: 5.0" - 10.5" LP: 10.5" - 14.0" OD: NG: 5.0" - 10.5" LP: 10.5" - 14.0" DV: NG: 5.0" - 10.5" LP: 10.5" - 14.0"	SV: NG: 4.0" - 10.5" LP: 8.0" - 14.0" OD: NG: 4.0" - 10.5" LP: 8.0" - 14.0" DVC: NG: 4.0" - 10.5" LP: 8.0" - 14.0"	DVC: NG: 4.0" - 10.5" LP: 8.0" - 14.0"
Energy Factor	n/a	SV: 0.83 (NG), 0.83 (LP) OD: 0.82 (NG), 0.86 (LP) DVC: 0.82 (NG), 0.84 (LP)	SV: 0. (NG), 0. (LP) OD: 0. (NG), 0. (LP) DVC: 0. (NG), 0. (LP)
Thermal Efficiency	84%	84%	85%
Max Hot Water Capacity	45° F Rise: 9.3 Gal./min.	45° F Rise: 7.5 Gal./min.	45° F Rise: 6.7 Gal./min.
Capacity Range	0.5-11.1 Gal./min.	0.5-9.8 Gal./min.	0.5-8.3 Gal./min.
Installation	SV: Indoor/Outdoor, Wall Mounted OD: Outdoor, Wall Mounted DV: Indoor, Wall Mounted	SV: Indoor/Outdoor, Wall Mounted OD: Outdoor, Wall Mounted DVC: Indoor, Wall Mounted	Indoor, Wall Mounted
Air Supply/ Exhaust	SV: Power Vented, 4" Flue OD: Power Venting, No Venting DV: Direct Vent, 4" Intake & Exhaust	SV: Power Vented, 4" Flue OD: Power Vented, No Venting DVC: Power Vented, 3" x 5" Concentric Venting	Power Vented, 3" x 5" Concentric Venting
Ignition	Direct Ignition	Direct Ignition	Direct Ignition
Operating Pressure	15-150 psi	15-150 psi	15-150 psi
Minimum Flow Rate	0.5 GPM	0.5 GPM	0.5 GPM
Dimension	SV: 24.2" (H) x 18.3" (W) x 9.4" (D) OD: 24.2" (H) x 18.3" (W) x 9.4" (D) DV: 24.2" (H) x 18.3" (W) x 9.4" (D)	SV: 23.6" (H) x 13.8" (W) x 9.4" (D) OD: 23.6" (H) x 13.8" (W) x 9.4" (D) DVC: 23.6" (H) x 13.8" (W) x 10.2" (D)	23.6" (H) x 13.8" (W) x 9.4" (D)
Weight	SV: 62 (pounds) OD: 62 (pounds) DV: 62 (pounds)	SV: 47 (pounds) OD: 47 (pounds) DVC: 55 (pounds)	49 (pounds)
Water Holding Capacity	0.3 GPM	0.2 GPM	0.2 GPM
Water Inlet	3/4"	3/4"	3/4"
Hot Water Outlet	3/4"	3/4"	3/4"
Gas Inlet	3/4"	3/4"	3/4"
Supply	120 VAC (60 Hz)	120 VAC (60 Hz)	120 VAC (60 Hz)
Consumption	SV: NG: 115W LP: 115W OD: NG: 90W LP: 95W DV: NG: 115W LP: 120W	SV: NG: 62W LP: 75W OD: NG: 64W LP: 77W DVC: NG: 108W LP: 96W	NG: 82 LP: 90W
Temperature Settings	100-150°F (in 5°F intervals), 160, 170, 180°F (in 10°F intervals) (14 options)	100-150°F (in 5°F intervals), 160, 170, 180°F (in 10°F intervals) (14 options)	100-140°F (in 5°F intervals), (9 options)
Default Temperature Options	120, 130, 140, 180°F (Original is 120°F)	120, 130, 140, 180°F (Original is 120°F)	120, 130, 140, 140°F (Original is 120°F)
Included Accessories	SV: Remote Controller & Cord, Anchoring Screws, Power Cord OD: Remote Controller & Cord, Anchoring Screws DV: Remote Controller & Cord, Anchoring Screws	SV: Remote Controller & Cord, Anchoring Screws, Power Cord OD: Remote Controller & Cord, Anchoring Screws DVC: Anchoring Screws	Anchoring Screws

valueSOLUTIONS

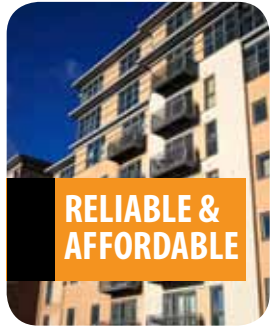

Specifications

NR71 SERIES

Up to 7.1 Gal./ min.
Indoor & Outdoor Install



NR66 SERIES

Up to 6.6 Gal./ min.
Indoor & Outdoor Install



NR50 SERIES

Up to 5.0 Gal./ min.
Outdoor Install



Gas Consumption (Natural Gas/Propane)	SV: 180,000 - 25,000 BTUH OD: 180,000 - 25,000 BTUH	SV: 140,000 - 20,000 BTUH OD: 140,000 - 20,000 BTUH	OD (NG): 120,000 - 19,000 BTUH OD (LP): 120,000 - 20,000 BTUH
Gas Supply Pressure	SV: NG: 4.0" - 10.5" LP: 8.0" - 14.0" OD: NG: 4.0" - 10.5" LP: 8.0" - 14.0"	SV: NG: 4.0" - 10.5" LP: 8.0" - 14.0" OD: NG: 4.0" - 10.5" LP: 8.0" - 14.0"	OD: NG: 4.0" - 10.5" LP: 8.0" - 14.0"
Energy Factor	SV: 0.83(NG), 0.83(LP) OD: 0.82(NG), 0.83(LP)	SV: 0.82(NG), 0.84(LP) OD: 0.83(NG), 0.84(LP)	OD: 0.82(NG), 0.82(LP)
Thermal Efficiency	83%	83%	83%
Max Hot Water Capacity	45° F Rise: 6.3 Gal./min.	45° F Rise: 5.3 Gal./min.	45° F Rise: 4.2 Gal./min.
Capacity Range	0.5-7.1 Gal./min.	0.5-6.6 Gal./min.	0.5-5.0 Gal./min.
Installation	SV: Indoor/Outdoor, Wall Mounted OD: Outdoor, Wall Mounted	SV: Indoor/Outdoor, Wall Mounted OD: Outdoor, Wall Mounted	OD: Outdoor, Wall Mounted
Air Supply/ Exhaust	SV: Power Vented, 4" Flue OD: Power Venting, No Venting	SV: Power Vented, 4" Flue OD: Power Vented, No Venting	OD: Power Vented, No Venting
Ignition	Direct Ignition	Direct Ignition	Direct Ignition
Operating Pressure	15-150 psi	15-150 psi	15-150 psi
Minimum Flow Rate	0.5 GPM	0.5 GPM	0.5 GPM
Dimension	SV: 23.6" (H) x 13.8" (W) x 6.7" (D) OD: 23.6" (H) x 13.8" (W) x 6.7" (D)	SV: 20.5" (H) x 13.8" (W) x 6.7" (D) OD: 20.5" (H) x 13.8" (W) x 6.7" (D)	OD: 20.5" (H) x 13.8" (W) x 6.7" (D)
Weight	SV: 41 (pounds) OD: 41 (pounds)	SV: 36 (pounds) OD: 36 (pounds)	OD: 33 (pounds)
Water Holding Capacity	0.2 GPM	0.2 GPM	0.2 GPM
Water Inlet	3/4"	3/4"	3/4"
Hot Water Outlet	3/4"	3/4"	3/4"
Gas Inlet	3/4"	3/4"	1/2"
Supply	120 VAC (60 Hz)	120 VAC (60 Hz)	120 VAC (60 Hz)
Consumption	SV: NG: 59W LP: 66W OD: NG: 46W LP: 50W	SV: NG: 54W LP: 59W OD: NG: 51W LP: 52W	OD: NG: 36W LP: 39W
Temperature Settings	100-150° F (in 5° F intervals), 160° F (12 options)	100-150° F (in 5° F intervals), 160° F (12 options)	100-150° F (in 5° F intervals), 160° F (12 options)
Default Temperature Options	120, 130, 140° F (Original is 120° F)	120, 130, 140° F (Original is 120° F)	120, 130, 140° F (Original is 120° F)
Included Accessories	SV: Anchoring Screws, Power Cord OD: Anchoring Screws	SV: Anchoring Screws, Power Cord OD: Anchoring Screws	OD: Anchoring Screws Freeze Protection (optional)

Accessories



Remote Controller



Pipe Cover



Isolation Valves



Recess Box



ScaleShield



H₂FLOW



Outdoor Junction Box



Temp/Pressure Gauge



Neutralizer

Accessories	Descriptions	Part Number	NR50 NR66		NR71		NR83 NR98			NRC111 NCC199		NR111 NC250			NC199		NC380	NH			
			SV	OD	SV	OD	SV	DVC	OD	SV	DV	SV	DV	OD	DVC	OD	SV	150	199		
Remote Controller	Remote Controller	RC-7649M RC-7650M (CAN)	✓	✓	✓	✓	✓*		✓*	✓*	✓*	✓*	✓*	✓*	✓*	✓*					
Remote Controller Cord	10' Length	RC-CORD10	✓	✓	✓	✓	✓*		✓*	✓*	✓*	✓*	✓*	✓*	✓*	✓*					
	26' Length	RC-CORD26	✓	✓	✓	✓	✓		✓	✓	✓	✓	✓	✓	✓	✓					
RC Outdoor Junction Box	RC-OJB	0700757	✓	✓	✓	✓	✓		✓	✓		✓		✓		✓					
Pipe Covers	Pipe Cover	PC-1S	✓	✓	✓	✓															
	Pipe Cover	PC-2S					✓		✓												
	Pipe Cover	PC-2S-GRY														✓					
	Pipe Cover	PC-3S								✓	✓	✓	✓	✓							
	Pipe Cover	PC-5S							✓												
	Pipe Cover	PC-5S-GRY														✓					
	Pipe Cover	PC-3S-SUS									✓	✓	✓	✓	✓						
	Pipe Cover	PC-4S-SUS																✓			
Quick-Connect Cable	2-units only	QC-1					✓	✓	✓	✓	✓	✓	✓	✓	✓	✓	✓				
	2-units only	QC-2 (NR83 only)							✓												
System Controller	Up to 6 units	SC-201-6M									✓	✓	✓	✓	✓			✓			
	Up to 6 units	SC-201-6M-EXT-OD															✓				
	Up to 6 units	SC-201-6M-EXT-DVC														✓***					
	Up to 12 Units	SC-201-12M									✓	✓	✓	✓	✓			✓			
	Up to 24 Units	SC-201-24M									✓	✓	✓	✓	✓			✓			
Isolation Valves	Isolation Valves (Includes Pressure Relief Valve) For lead free isolation valves and adapters, add "-LF" to the part number	IK-WV-200-1-TH	✓	✓	✓	✓	✓	✓	✓	✓	✓	✓	✓	✓	✓	✓					
		IK-WV-200-1-SW	✓	✓	✓	✓	✓	✓	✓	✓	✓	✓	✓	✓	✓	✓	✓				
		IK-WV-300-1-TH																	✓	✓	✓
		IK-WV-300-1-SW																	✓	✓	✓
Recess Box	NR50-OD/NR66-OD	RB-500		✓																	
	NR71-OD	RB-600				✓															
	NR98-OD/NC199-OD	RB-700							✓								✓				
	NR111-OD	RB-900														✓					
ScaleShield	ScaleShield	SS-HB-1	✓	✓	✓	✓	✓	✓	✓	✓	✓										
		SS-HB-2											✓	✓	✓	✓	✓	✓**			
ScaleShield Refill Cartridges	1 Each	HBC-1	✓	✓	✓	✓	✓	✓	✓	✓	✓										
	1 Each	HBC-2											✓	✓	✓	✓	✓	✓**			
H ₂ FLOW	H2Flow	H2F	✓	✓	✓	✓	✓	✓	✓	✓	✓	✓	✓	✓	✓	✓	✓	✓	✓		
H ₂ FLOW Refill Cartridge	1 Each	H2F-C	✓	✓	✓	✓	✓	✓	✓	✓	✓	✓	✓	✓	✓	✓	✓	✓	✓		
Temp/Pressure Gauge	(75 PSI, 320° F)	TPG1-30																✓*	✓*		
Safety Relief Valve	Safety Relief Valve	HTGSRV-1																✓*	✓*		
Neutralizer	Neutralizer Cartridge	SKD7466									✓*	✓*									

SV= Standard Vent, DV= Direct Vent, OD= Outdoor Model, DVC= Concentric Vent
* Included with heater purchase. ** Two units required. *** RC-Cords will need to be purchased. ****Please contact Noritz for commercial sizing.



NORITZ HYDRONIC BOILER

OUR WATER CONDITIONING SOLUTION:

- ✓ MAINTAINS ENERGY EFFICIENCY
- ✓ REDUCES MAINTENANCE
- ✓ REMOVES EXISTING SCALE

According to the United States Geological Survey, 89.3% of the US homes have hard water. Over 85% of Canada has a hard water problem.

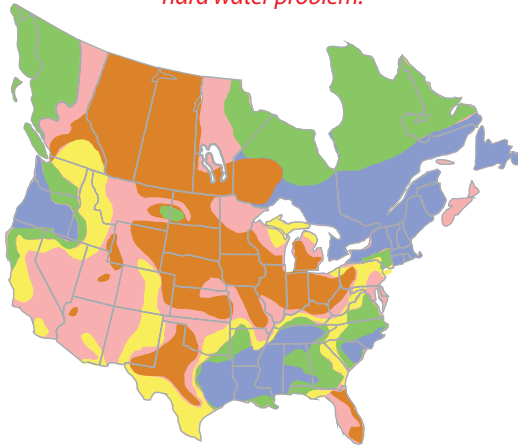

Water Supply Classifications	
less than 3 gpg	Slightly Hard
3 to 7 gpg	Moderately Hard
7 to 10 gpg	Hard
10 to 14 gpg	Very Hard
over 14 gpg	Extremely Hard
gpg = grains per gallons	

CONSEQUENCES OF HARD WATER: The harder the water, the more aggressive it is on appliances, especially water heaters. Water that is heated allows the dissolved minerals to come out of solution and deposit inside the water heater. Over time this scale reduces the performance as well as the longevity of a water heater.

H₂FLOW: Hard Water Solution

The Ultimate in Scale Protection

H₂FLOW is the answer to effectively handle hard water scale build up that can affect the performance of your appliance. This breakthrough technology has now been made available for all water heater types, including tankless, boilers, and tank type water heaters.

H₂FLOW is an economical solution to hard scale build up that can help to protect your appliance for years to come.

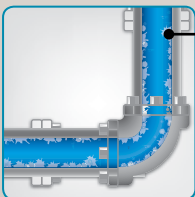
Scale is an incrustation of calcium carbonate (CaCO₃) that forms on pipes and heating elements. The H₂FLOW uses TAC to attract hardness minerals that do not stick to pipes and components.

1st Asme Certified Tankless Hydronic Boilers For Residential & Commercial Applications.



Energy Efficient & Space Saving

Specifications

	NH199 SERIES	NH150 SERIES
	Flow range 17 - 4 gpm Indoor Install	Flow range 17 - 4 gpm Indoor Install
	DV	DV
Gas Consumption (Natural Gas/Propane)	199,900 - 55,500 BTUH	150,000 - 55,500 BTUH
Gas Supply Pressure	DV: NG: 4.0" - 10.5" LP: 8.0" - 14.0"	DV: NG: 4.0" - 10.5" LP: 8.0" - 14.0"
Energy Factor	82.7%(NG), 83% (LP)	83%(NG), 82.8%(LP)
Thermal Efficiency	82.7%(NG), 83% (LP)	83%(NG), 82.8%(LP)
Ignition	Direct Ignition	Direct Ignition
Operating Pressure	15-30 psi	15-30 psi
Minimum Flow Rate	4 GPM	4 GPM
Dimension	24.2" (H) x 9.4" (W) x 10.0" (D)	24.2" (H) x 9.4" (W) x 10.0" (D)
Weight	63.5 (pounds)	63.5 (pounds)
Water Holding Capacity	0.4 GPM	0.4 GPM
Water Inlet	1"	1"
Hot Water Outlet	1"	1"
Gas Inlet	3/4"	3/4"
Supply	120 VAC (60 Hz)	120 VAC (60 Hz)
Consumption	NG: 97W LP: 111W	NG: 93W LP: 93W
Temperature Settings	140-180°F (in 5°F intervals)	140-180°F (in 5°F intervals)
Unit Type	Boiler - Indoor hanging wall -Direct Vent/ Sealed Combustion Closed Loop	Boiler - Indoor hanging wall -Direct Vent/ Sealed Combustion Closed Loop
Included Accessories	SV: Anchoring Screws, Power Cord OD: Anchoring Screws	SV: Anchoring Screws, Power Cord OD: Anchoring Screws

Advanced features include:

- Commercial-grade copper heat exchanger made thicker to help resist corrosion.
- Pipe with larger diameter specifically designed for the boiler dramatically reduces pressure loss through the multi-pass heat exchanger.
- Standard integrated priority controls for DHW and hydronic heating systems from a single controller on the front panel.
- Two temperature settings; 1 for the DHW and 1 for the heating system.
- High temperature capability (up to 180°F). Nine temperature option settings.
- Low maintenance – minimal moving parts (fan and flow switch only).
- Durable, fully solid state controls.

Warranty Info

10 year

Heat Exchanger

1 year

Warranty on Parts

Boiler Warranty

Noritz offers a 10-year warranty on the heat exchanger and a 1-year warranty on parts.

Commercial Advantage

Modular
Multi-System
Modulation
Intelligent System



Modular

The Noritz modular system is based on a single self-contained, interchangeable unit that can combine and communicate with like units to meet any hot water demand.

Multi-System

Noritz units can be linked together with a single system controller, up to 24 units. This allows outputs of 9.1 million Btu/h and 316 gallons per minute.

Modulation

Noritz fully modulating technology can track any hot water demand with pin point accuracy, only using the energy necessary to heat the water that is used.

Intelligent System

In a multi-system setup, the Noritz commercial units will communicate with one another and work in unison to even out the load on each individual unit, maximizing output and system life. With the ability to modulate between multiple units with the use of a system controller makes Noritz commercial water heaters the most efficient water heating system on the market today.



Fully Modulating Burner

Noritz's fully modulating burner technology is the most precise and efficient method of heating high fluctuating demands of water.

Single Unit

23:1 Turndown Ratio
11,000 - 250,000 BTU Range

24 Units (Modular)

545:1 Turndown Ratio
11,000 - 6 Million BTU Range

(Specs based on NC250 model)

Intelligent System

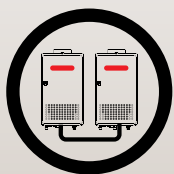
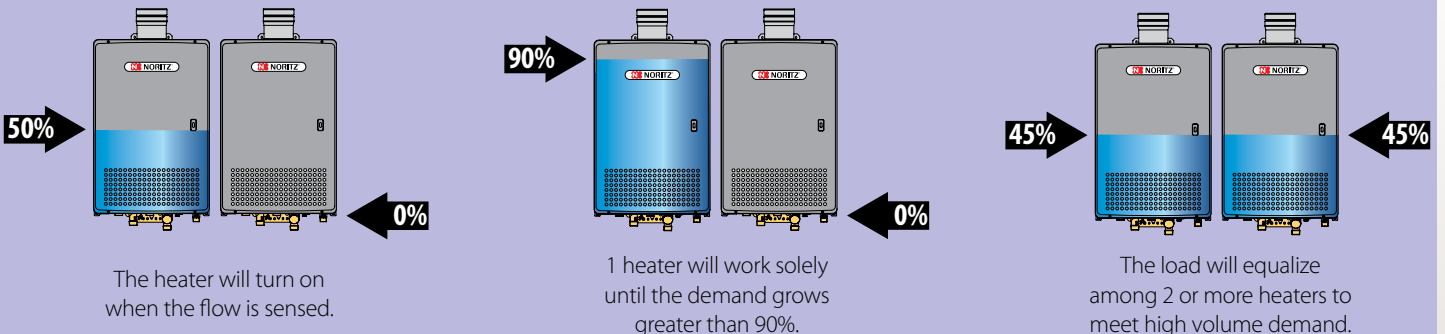

Redundancy

Any one of the Noritz commercial units on a multi-system can be taken offline and serviced without compromising your business. Hot water will still be provided by the other units.



Efficiency

Because of the modulating technology, a Noritz commercial system heats water using only the energy necessary to meet the demand, reducing energy consumption significantly and saving on water heating costs.



Versatile Installation

Noritz commercial units can be installed indoor or outdoor and because of its size and weight, they can be wall hung or racked, making spaces once thought impossible, possible.

ADVANCED SOLUTIONS

Modular Concept

Noritz modular system can link up to 24 units. The system is based on a single self-contained, interchangeable unit that can combine and communicate with like units to meet any hot water demand.

Commercial H2Flow

- Designed for all water heater types and models regardless of manufacturer
- Prevents the formation of scale to improve efficiency and prolongs the life of the water heater
- Uses no salt or harmful chemicals and provides a more environmentally friendly alternative to water softeners
- 3/4", 1", 1-1/4", and 2" connections available for quick and easy installations and servicing
- Low Maintenance - replace the H2Flow media once every three years
- High-capacity units are also available for unlimited service flow rates when manifolded



Common Venting

Noritz offers common venting solutions for commercial installations. Our knowledgeable technical consultants are available at 866-766-7489.

Racking Systems

- Pre-fabricated racking system for commercial multisystem installations
- Can hold 2 Noritz tankless water heaters back to back and provides mounting holes for a quick and precise installation
- Provides a time and labor saving solution when installing multiple water heaters
- Manufactured with highly corrosion-resistant steel that can withstand extreme environments
- Perfect for flat rooftop or mechanical room applications



Warranty Info

5 year Heat Exchanger

5 year Warranty on Parts

Commercial Warranty

Noritz offers a 5-year warranty on the heat exchanger and a 5-year warranty on parts.

NC380- ASME SERIES

High Capacity
380,000 BTUH
Indoor & Outdoor Install



NC250- ASME SERIES

High Capacity
250,000 BTUH
Indoor & Outdoor Install



NCC199 SERIES

High Efficiency
199,900 BTUH
Indoor & Outdoor Install

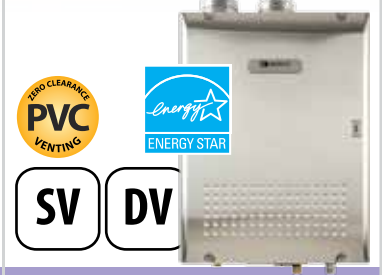

Specifications

Gas Consumption (Natural Gas/Propane)	380,000 - 22,500 BTUH	SV: 250,000 - 11,000 BTUH DV: 250,000 - 11,000 BTUH	SV: 199,900 - 11,000 BTUH DV: 199,900 - 11,000 BTUH
Gas Supply Pressure	SV: NG: 5.0" - 10.5" LP: 10.5" - 14.0"	SV: NG: 5.0" - 10.5" LP: 10.5" - 14.0" DV: NG: 5.0" - 10.5" LP: 10.5" - 14.0"	SV: NG: 4.0" - 10.5" LP: 8.0" - 14.0" DV: NG: 4.0" - 10.5" LP: 8.0" - 14.0"
Energy Factor	n/a	n/a	SV: 0.91 (NG), 0.93 (LP) DV: 0.92 (NG), 0.94 (LP)
Thermal Efficiency	80% (NG), 84% (LP)	84%	SV: 93%, DV: 93.3% (NG), 93.9% (LP)
Max Hot Water Capacity	45° F Rise: 13.2 Gal./min.	45° F Rise: 9.3 Gal./min.	45° F Rise: 8.4 Gal./min.
Capacity Range	0.7 - 13.2 Gal./min.	0.5-11.1 Gal./min.	0.5-11.1 Gal./min.
Installation	Indoor/Outdoor, Wall Mounted	SV: Indoor/Outdoor, Wall Mounted DV: Indoor, Wall Mounted	SV: Indoor/Outdoor, Wall Mounted DV: Indoor, Wall Mounted
Air Supply/ Exhaust	Power Vented, 5" Flue	SV: Power Vented, 4" Flue DV: Direct Vent, 4" Intake & Exhaust	SV: Power Vented, 4" Flue DV: Direct Vent, 4" Intake & Exhaust
Ignition	Direct Ignition	Direct Ignition	Direct Ignition
Operating Pressure	15-150 psi	15-150 psi	15-150 psi
Minimum Flow Rate	0.7 GPM	0.5 GPM	0.5 GPM
Dimension	29.7" (H) x 19.1" (W) x 11.8" (D)	SV: 24.2" (H) x 18.3" (W) x 9.4" (D) DV: 24.4" (H) x 18.4" (W) x 9.4" (D)	SV: 24.4" (H) x 18.4" (W) x 9.4" (D) DV: 24.4" (H) x 18.4" (W) x 9.4" (D)
Weight	106 (pounds)	SV: 62 (pounds) DV: 62 (pounds)	SV: 73 (pounds) DV: 73 (pounds)
Water Holding Capacity	0.6 GPM	0.3 GPM	0.5 GPM
Water Inlet	1"	3/4"	NPT 3/4"
Hot Water Outlet	1"	3/4"	NPT 3/4"
Gas Inlet	1"	3/4"	NPT 3/4"
Supply	120 VAC (60 Hz)	120 VAC (60 Hz)	120 VAC (60 Hz)
Consumption	NG: 137W LP: 142W, Freeze Protect. 371W	SV: NG: 115W LP: 115W DV: NG: 115W LP: 120W	SV: NG: 106W LP: 109W DV: NG: 115W LP: 120W
Temperature Settings	100-150° F (in 5° F intervals), 160, 170, 180° F (in 10° F intervals) (14 options)	100-150° F (in 5° F intervals), 160, 170, 180° F (in 10° F intervals) (14 options)	100-150° F (in 5° F intervals), 160, 170, 180° F (in 10° F intervals) (14 options)
Default Temperature Options	120, 130, 140, 180° F (Original is 120° F)	120, 130, 140, 180° F (Original is 120° F)	120, 130, 140, 180° F (Original is 120° F)
Included Accessories	Remote Controller & Cord, Anchoring Screws	SV: Remote Controller & Cord, Anchoring Screws, Power Cord DV: Remote Controller & Cord, Anchoring Screws	SV: Remote Controller & Cord, Anchoring Screws DV: Remote Controller & Cord, Anchoring Screws

NC199 SERIES

Commercial Unit
199,900 BTUH
Indoor & Outdoor Install



Specifications

Gas Consumption (Natural Gas/Propane)	OD: 199,900 - 12,000 BTUH DVC: 199,900 - 11,000 BTUH
Gas Supply Pressure	OD: NG: 4.0" - 10.5" LP: 8.0" - 14.0" DVC: NG: 4.0" - 10.5" LP: 8.0" - 14.0"
Energy Factor	OD: 0.82 (NG), 0.86 (LP) DVC: 0.82 (NG), 0.84 (LP)
Thermal Efficiency	84%
Max Hot Water Capacity	45°F Rise: 7.5 Gal./min.
Capacity Range	0.5-9.8 Gal./min.
Installation	OD: Outdoor, Wall Mounted DVC: Indoor, Wall Mounted
Air Supply/ Exhaust	OD: Power Vented, No Venting DVC: Power Vented 3" x 5" Concentric Venting
Ignition	Direct Ignition
Operating Pressure	15-150 psi
Minimum Flow Rate	0.5 GPM
Dimension	OD: 23.6" (H) x 13.8" (W) x 9.4" (D) DVC: 23.6" (H) x 13.8" (W) x 10.2" (D)
Weight	OD: 47 (pounds) DVC: 55 (pounds)
Water Holding Capacity	0.2 GPM
Water Inlet	3/4"
Hot Water Outlet	3/4"
Gas Inlet	3/4"
Supply	120 VAC (60 Hz)
Consumption	OD: NG: 64W LP: 77W DVC: NG: 108W LP: 96W
Temperature Settings	100-150°F (in 5°F intervals), 160, 170, 180°F (in 10°F intervals) (14 options)
Default Temperature Options	120, 130, 140, 180°F (Original is 120°F)
Included Accessories	OD: Remote Controller & Cord, Anchoring Screws DVC: Anchoring Screws

COMMERCIAL UNITS: ACCESSORIES

Accessories	Part Number	NC380		NC250		NCC199		NC199	
		SV	SV	DV	SV	DV	OD	DVC	
Remote Controller	RC-7649	✓*	✓*	✓*	✓*	✓*	✓*	✓*	✓*
	RC-7650M (Can)	✓*	✓*	✓*	✓*	✓*	✓*	✓*	✓*
Remote Controller Cord	RC-CORD10	✓*	✓*	✓*	✓*	✓*	✓*	✓*	✓*
	RC-CORD26	✓	✓	✓	✓	✓	✓	✓	✓
Remote Controller Outdoor Junction Box	0700757	✓	✓		✓			✓	
Pipe Cover	PC-2S-GRY								✓
	PC-5S-GRY								✓
	PC-3S-SUS		✓	✓	✓	✓			
	PC-4S-SUS	✓							
Quick-Connect Remote Controller Cable	QC-1	✓	✓	✓	✓	✓	✓	✓	✓
System Controller (For Multi-System)	SC-201-6M	✓	✓	✓	✓	✓			
	SC-201-6M-EXT-OD							✓	
	SC-201-6M-EXT-DVC								✓
	SC-201-12M	✓							
	SC-201-24M	✓							
Isolation Valve Kit <small>For lead free isolation valves and adapters, add "-LF" to the part number</small>	IK-WV-200-1-TH		✓	✓	✓	✓	✓	✓	✓
	IK-WV-200-1-SW		✓	✓	✓	✓	✓	✓	✓
	IK-WV-300-1-TH	✓							
	IK-WV-300-1-SW	✓							
Commercial H2FLOW Water Treatment	CH2F-**	✓	✓	✓	✓	✓	✓	✓	✓
Commercial H2FLOW Replacement Media	CH2FC-**	✓	✓	✓	✓	✓	✓	✓	✓
Neutralizer Kit	SKD7466				✓*	✓*			
Commercial Rack System (Hangs 2 units Tandem)	MR-2	✓	✓	✓	✓	✓	✓	✓	✓

**MAX Gallons per minute capacity

Concentric Venting for DVC Models

DVC



Features:

- Push-on connection
- Single-wall penetration
- No need to cut - adjustable for easy installations
- Zero clearance to combustibles
- Use of superior anti-corrosion material 316L for outlet port
- Heat and chemical resistant flourine rubber O-ring for secure sealing

Horizontal Installation

Horizontal- Kits

Standard Wall Kit
Includes inner & outer plates
CVK-H
Wall Thickness Range
From 5.8"-13.2"

Thick Wall Kit
Includes inner & outer plates
CVK-H2
Wall Thickness Range
From 10.3"-17.8"

Horizontal- Build Your Own

Direct connection without straight
3.9~7.1 in

Direct connection without straight
3.9~7.1 in

No	1	2	3	4	5	6	7
Description	Straight Bird Screen w/ Outer Plate	90° Adj w/ Wall Flange	Straight Vent Pipe w/ Wall Flange	Straight	Adjustable	45/ 90 Degree	Drain Tee
Part Number	CVT-S	CWF-90ELB	CWF	CVP-4/12/24/36STR	CVP-11/16/40ADJ	CVP-45/90ELB	CDT-V

Vertical Installation

Vertical Kit Cold Weather

- **CVK-V-CF** (0-15 Degrees)
- **CVK-V-CA** (15-45 Degrees)

CVK-V-CF Contents		
No	Description	Part Number
1	Rain Cap	CRC
2	Air Intake Pipe W/ Snap Connection	CAIP1
3	Storm Collar	CSCR
4	Flat Roof Flashing (0-15 Degrees)	CFRF
5	Drain Tee	CDT-V

CVK-V-CA Contents		
No	Description	Part Number
1	Rain Cap	CRC
2	Air Intake Pipe W/ Snap Connection	CAIP1
3	Storm Collar	CSCR
4	Angled Roof Flashing (15-45 Degrees)	CARF
5	Drain Tee	CDT-V

Vertical Kit Warm Weather

- **CVK-V-F** (0-15 Degrees)
- **CVK-V-A** (15-45 Degrees)

CVK-V-F Contents		
No	Description	Part Number
1	Rain Cap w/ Air Intake Pipe	CRCAI
2	Storm Collar	CSCR
3	Flat Roof Flashing (0-15 Degrees)	CFRF

CVK-V-A Contents		
No	Description	Part Number
1	Rain Cap w/ Air Intake Pipe	CRCAI
2	Storm Collar	CSCR
3	Angled Roof Flashing (15-45 Degrees)	CARF

Concentric Vent Pieces (Dia. 3" Inner / 5" Outer)



Snorkel Kit

① Vertical*		② Wall Thickness*
a	b	c
23.91"~29.72"	27.41"~33.22"	16.45"~19.26"

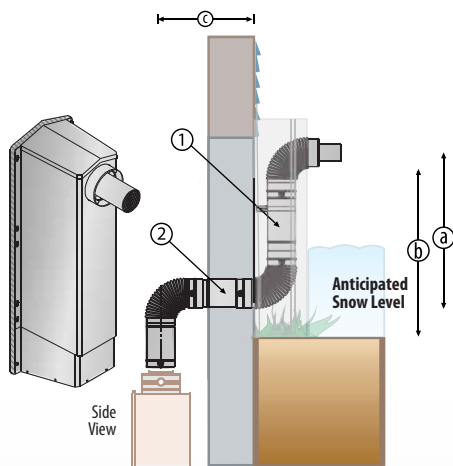

BASEMENT

*Additional vent pieces can be used to increase the vertical and wall thickness lengths.

Snorkel Kit (CVK-SNRK) Contents

PCS	Description	Part #
1	Snorkel case top	SNRK-C1
2	Snorkel case bottom	SNRK-C2
3	Concentric 11" adjustable vent pipe	CVP-11ADJ
4	Concentric 16" adjustable vent pipe	CVP-16ADJ
5	Concentric snorkel termination elbow	CVT-SNRK-90ELB
6	Concentric 90 degree elbow	CVP-90ELB
7	Concentric 90 degree adjustable elbow	CVP-90ADJELB
8	Adjustable support strap	SS5-3ADJ
9	Screw set	S-12



Cosmetic Ring

Description	Part #
5" Cosmetic Ring	CR5-SUS

Type	Description	Part Number	Qty/Box	Dimensions		Drawing
				L1	L2	
Rigid	4" Straight	CVP-4STR	6	3.3"		
	12" Straight	CVP-12STR	6	11.8"		
	24" Straight	CVP-24STR	6	23.6"		
	36" Straight	CVP-36STR	6	35.4"		
Adjustable	11" Adjustable	CVP-11ADJ	6	8.3" - 11.2"		
	16" Adjustable	CVP-16ADJ	6	11.0" - 16.7"		
	40" Adjustable	CVP-40ADJ	6	22.8" - 40.6"		
Elbow	45° Elbow	CVP-45ELB	6	5.3"	2.2"	
	90° Elbow	CVP-90ELB	6	8.1"	4.9"	
	90° Adj. Elbow	CVP-90ADJELB	6	12.6" - 15.8"	4.9"	
Inner Wall Pieces	Straight w/Wall Flange	CWF	6	8.7"	8.7"	
	90° Adj. Elbow w/ Wall Flange	CWF-90ELB	6	12.6" - 15.8"	8.7"	
Drain Tee	Vertical Drain Tee	CDT-V	6	0.47"	8.3"	
Roof Pieces	Angled Roof Flashing (15°-45° Pitch)	CARF	1	19.3"	10.5"	
	Flat Roof Flashing (0°-15° Pitch)	CFRF	1	19.3"	10.5"	
	Storm Collar Ring	CSCR	1	1.2"	9.1"	
Terminations	(Cold Weather) Rain Cap	CRC	1	10.6"	19.9"	
	Air Intake Pipe for (Cold Weather) Rain Cap	CAIP1	1	16.5"	2"	
	Air Intake Pipe w/ (Warm Weather) Rain Cap	CRCAI	1	26.2"	13.3"	
	Straight Bird Screen	CVT-S	6	11.0"	3.9"	
	Face Plate	FP-5-OUT	1	6.7"	8.7"	
Others	Bug Guard for Horizontal Terminations	BG-DVC-H	1	Extendable	5"	
	Bug Guard for Vertical Terminations	BG-DVC-V	1	Extendable	5"	
	Support Strap (1" Clearance)	SS5-1	5 Sets	6.8"	1"	
	Support Strap (2" Clearance)	SS5-2	5 Sets	7.8"	2"	
	Support Strap (4" Clearance)	SS5-4	5 Sets	9.8"	4"	
Support Strap (6" Clearance)	SS5-6	5 Sets	11.8"	6"		

Note: The DVC water heater and vent pipe are considered one system and have approved as such. The DVC-Vent Line is approved for use on Noritz product only.

PVC Venting for Condensing Models



New Plastic Vent Termination

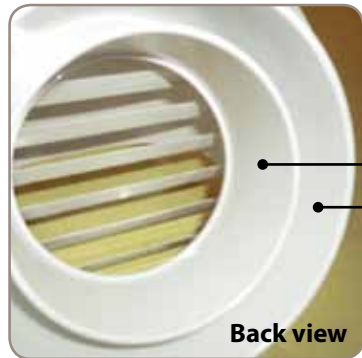

Back view

For 3" PVC & CPVC
For 4" PVC & CPVC

Plastic Vent Termination

- 3" and 4" in one design
- Hood / Louver Convertible
- Fits Schedule 40 PVC & CPVC
- Direct connection to PVC pipe

PART# PVT-HL



Professional Finish: 2 in 1 Design

Removable Hood



Louver



3" PVC Concentric Horizontal Termination Kit

VK3-H-PVC Specifications & Features:

- 3" Diameter for intake/exhaust
- 4.5" Diameter for termination
- Easy Installation

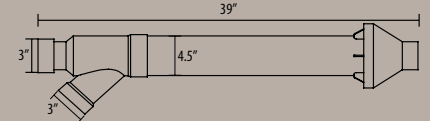

(Condensing DV units only)

NRC98 and NRC80 Series

COMING SOON! Accepts 3" or 4" PVC Sizes.



Vent Flue

3" Diameter
4" Diameter

- 3" and 4" socket sizes in one design.
- Fits Schedule 40 & 80.
- Direct connection to PVC Pipe - no need for a coupling.

Bird Screen Images



Side



Front



Cosmetic Ring

Others

Description	Part #
Outdoor Vent Cap	VC-4C
3" PVC Bird Screen	VT3-PVCS
4" PVC Bird Screen	VT4-PVCS
3" PVC Cosmetic Ring	CR3-PVC
4" PVC Cosmetic Ring	CR4-PVC



Vent Cap

NRC111 Series

- PVC Pipe*
- PVC Coupling* (SCH. 40)
- Built-in 4" PVC Adapter



Direct PVC Connection!

*These are not included

NCC199 Series

COMMERCIAL

PVC Adapter Required

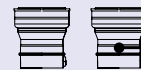

3" PVC Adapter



4" PVC Adapter



NCC199 Series is designed to use PVC or Stainless Steel for venting.

Description	Part #
3" PVC Adapter	VP4X3-ADAPT-PVC
4" PVC Adapter	VP4-ADAPT-PVC
DV Short Termination Adapter	VT4-TS-ADAPT

Stainless Steel Venting for SV and DV Models

SV

N-Vent Horizontal Vent Kit

VK4-H-*

Specifications & Features

- Stainless Steel
- 4" Diameter
- Flexibility for different wall thicknesses
- Easy installation
- Professional appearance

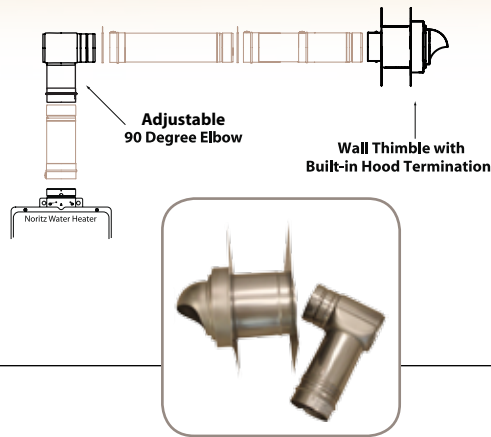

Part Number Based on Wall Thickness as Follows:

Wall Thickness	*Venting Kit Number
4.1" - 7.4"	VK4-H-8-1
7.4" - 14"	VK4-H-14-1

Horizontal Kit Contains:

Description	Part Number	Quantity
Wall Thimble with Built-in Hood Termination	WT4-H-#-1 (# Based on wall thickness)	1
Vertical Adjustment Range (7.5" - 11")	VP4-90ADJELB	1

SV

N-Vent Vertical Vent Kit

VK4-V1

Specifications & Features

- Stainless Steel
- 4" Diameter
- Easy installation
- Professional appearance

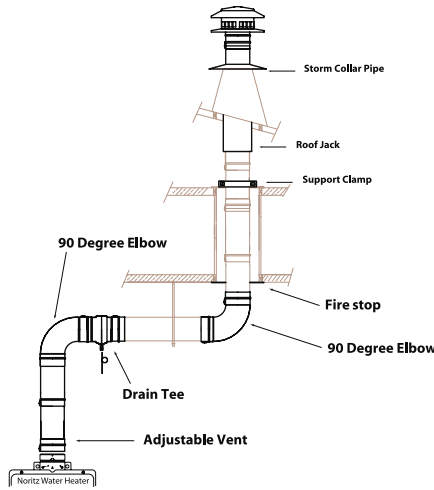

Vertical Kit Contains:

Description	Part Number	Quantity
Drain Tee	DT4	1
90 Degree Elbow	VP4-90ELB	2
Firestop	FS4	1
Support Clamp	SC4	1
Roof Jack	RJ4	1
Storm Collar Pipe	SCP4	1
Rain Cap	RC4	1
9" - 13.4" Adjustable Vent	VP4-13.4ADJ	1

DV

N-Vent Direct Vent Long Termination

Specifications & Features

- Stainless Steel
- 4" Diameter
- Easy installation
- Professional appearance

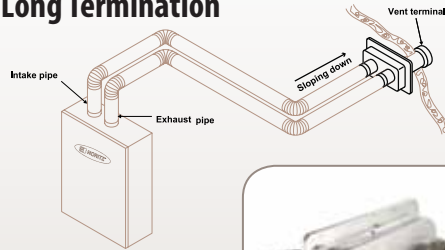

Use a listed Category III vent adaptor to connect the flue collar to the vent system. Use Category III vent pipe for the entire length of the exhaust pipe.

Part Name	Type	Wall Thickness	Dimensions (inches)		Part Number	Qty/ Box
			Sleeve**	Termination** (L2)		
Vent Termination	Long	3.5" - 5.1"	3.5" - 5.0"	7.0" - 8.5"	VT4-TL-5	1
			5.1" - 8.3"	8.5" - 12.0"	VT4-TL-8	1
		8.3" - 14.6"	8.0" - 15.0"	12.0" - 18.0"	VT4-TL-14	1
			15.0" - 27.0"	18.0" - 30.5"	VT4-TL-27	1

**Sleeve and termination (L2) can be adjusted in increments of 0.4 inch

DV

N-Vent Direct Vent Short Termination

Specifications & Features

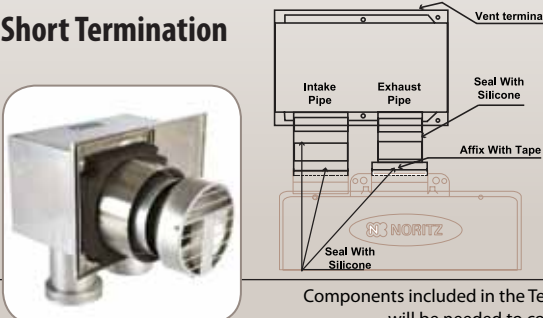

- Stainless Steel
- 4" Diameter
- Easy installation
- Professional appearance



Part Name	Type	Wall Thickness	Dimensions (inches)		Part Number	Qty/ Box
			Sleeve**	Termination** (L2)		
Vent Termination	Long	3.5" - 5.1"	3.5" - 5.0"	7.0" - 8.5"	VT4-TS-5	1
			5.1" - 8.3"	8.5" - 12.0"	VT4-TS-8	1
		8.3" - 14.6"	8.0" - 15.0"	12.0" - 18.0"	VT4-TS-14	1
			15.0" - 27.0"	18.0" - 30.5"	VT4-TS-27	1

Components included in the Termination Kits are shown in bold and listed in the charts. Note: Additional venting components will be needed to complete most vent runs. **Sleeve and termination (L2) can be adjusted in increments of 0.4 inch

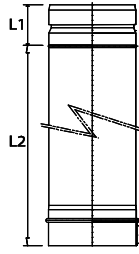
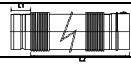
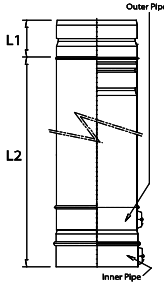
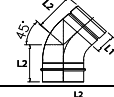
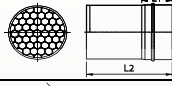
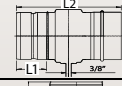
Stainless Steel Venting for SV and DV models

Type	Description	Dia.	Part Number	Qty/Box	Dimensions		Drawing
					L1	L2	
Rigid	6" Straight	4"	VP4-6STR	6	2.1"	6.0"	
		5"	VP5-6STR	6	2.7"		
	12" Straight	3"	VP3-12STR	6	2.0"	12.0"	
		4"	VP4-12STR	6	2.1"		
	24" Straight	3"	VP3-24STR	6	2.0"	24.0"	
		4"	VP4-24STR	6	2.1"		
		5"	VP5-24STR	6	2.7"		
	36" Straight	3"	VP3-36STR	6	2.0"	36.0"	
		4"	VP4-36STR	6	2.1"		
		5"	VP5-36STR	6	2.7"		
	48" Straight	3"	VP3-48STR	6	2.0"	48.0"	
		4"	VP4-48STR	6	2.1"		
5"		VP5-48STR	6	2.7"			
18" Semi Flexible	4"	VP4-18FLEX	6	2.1"	6.2"		
	5"	VP5-18FLEX	6	2.1"	6.2"		
Adjustable	9.4" Adjustable	3"	VP3-9.4ADJ	6	2.0"	6.8" - 9.1"	
		4"	VP4-9.4ADJ	6	2.1"		
		5"	VP5-9.4ADJ	6	2.7"		
	13.4" Adjustable	3"	VP3-13.4ADJ	6	2.0"	9.5" - 14.6"	
		4"	VP4-13.4ADJ	6	2.1"		
		5"	VP5-13.4ADJ	6	2.7"		
	21.4" Adjustable	3"	VP3-21.4ADJ	6	2.0"	15.4" - 26.5"	
		4"	VP4-21.4ADJ	6	2.1"		
		5"	VP5-21.4ADJ	6	2.7"		
	60" Adjustable	3"	VP3-60.OADJ	6	2.0"	36.0" - 60.0"	
4"		VP4-60.OADJ	6	2.1"			
Elbow	45° Elbow	3"	VP3-45ELB	6	2.0"	3.6"	
		4"	VP4-45ELB	6	2.1"	4.0"	
		5"	VP5-45ELB	6	2.7"	5.4"	
	90° Elbow	3"	VP3-90ELB	6	2.0"	5.2"	
		4"	VP4-90ELB	6	2.1"	6.2"	
Terminations	Straight Bird Screen	3"	VT3-S	6	2.0"	5.9"	
		4"	VT4-S	6	2.1"	6.2"	
		5"	VT5-S	6	2.7"	7.9"	
	45° Bird Screen	4"	VT4-S45	6	2.1"	4.0"	
		5"	VT5-S45	6	2.7"	5.4"	
	Hood	3"	VT3-SH	6	3.2"	5.5"	
		4"	VT4-SH	6	7.4"	6.1"	
		5"	VT5-SH	6	7.4"	6.6"	
	Louver	4"	VT4-SL	6	7.4"	3.2"	
		5"	VT5-SL	6	7.4"	3.7"	
	Rain Cap	3"	RC3	6	6.3"	6.8"	
		4"	RC4	6	7.8"	6.6"	
5"		RC5	6	11.0"	7.2"		
Drain Tee	Horizontal Drain Tee	3"	DT3	6	2.0"	7.1"	
		4"	DT4	6	2.1"	7.2"	
		5"	DT5	6	2.7"	8.0"	
	Vertical Drain Tee	3"	DT3-V	6	2.0"	5.1"	
		4"	DT4-V	6	2.1"	5.1"	
Roof Piece	Flat Roof Flashing	4"	FRF4	6	5.3"	17.0"	
		5"	FRF5	6	6.3"	18.0"	
	Angled Rood Flashing	3"	ARF3	1	5.0"	16.0"	
		4"	ARF4	1	6.0"	17.0"	
		5"	ARF5	1	7.0"	18.0"	
	Roof Jack	3"	RJ3	6	18.0"	4.0"	
		4"	RJ4	6		5.0"	
		5"	RJ5	6		6.0"	
	Storm Collar Pipe	4"	SCP4	1	2.1"	4.0"	
		5"	SCP5	1	2.7"	5.4"	
Storm Collar Ring	3"	SCR3	6	7.8"	3.0"		
	4"	SCR4	6	7.9"	4.0"		
	5"	CSCR	6	9.1"	1.2"		



Rigid



45° Elbow



45° Birdscreen



Hood Termination



Drain Tee



Rain Cap