

NIBCO®

AHEAD OF THE FLOW®



Bronze & Iron Valves

Business-to-Business Solutions

Look to NIBCO for technology leadership.

The velocity with which e-business evolves demands that new products and services be continuously developed and introduced to keep our customers at the center of our business efforts. NIBCO provides an entire suite of business-to-business solutions that is changing the way we interact with customers.



[NIBCOpartner.comSM](#) is an exclusive set of secure web applications that allow quick access to customer-specific information and online order processing. This self-service approach gives you 24/7 access to your order status putting you in total control of your business.

Real time information includes:

- Online order entry
- Viewable invoices & reports
- Inventory availability
- Current price checks
- Order status
- Online library of price sheets, catalogs & submittals



Electronic Data Interchange (EDI) makes it possible to trade business documents at the speed of light. This technology cuts the cost of each transaction by eliminating the manual labor and paperwork involved in traditional order taking. This amounts to cost-savings, increased accuracy and better use of resources.

With EDI, you can trade:

- Purchase orders
- PO Acknowledgements
- Invoices
- Product activity data
- Advanced ship notices
- Remittance advice



Vendor Managed Inventory (VMI), a sophisticated service for automated inventory management, reduces your overhead by transferring inventory management, order entry and forecasting to NIBCO. This is an on-going, interactive partnership with NIBCO.

Through automation, VMI brings results:

- Improves customer service
- Optimum inventory efficiencies
- Better forecasting
- Cuts transaction costs
- Peace of mind
- Relief from day-to-day management



Table of Contents

	Page		Page
Figure Number Key	4	Iron Check Valves	62-71
Bronze Gate Valves	5-19	Illustrated Index	62
Illustrated Index	5	F/T-918	63
T/S-111	6	F-918-N	64
T/S-113	7	F-968	65
T-113-HC	8	W-910/W-960	66
T-124	9	F-910/F-960	67
T-131	10	W-920-W-LF	68, 69
T-133	11	W-920-W	70
T/S-134	12	G-920-W	71
T-134 (Bolted Bonnet)	13	Iron Y-Strainers	72-73
T/S-136	14	T-751-A	72
T-136 (Bolted Bonnet)	15	F-721-A	73
T-154-A	16	Ductile and Alloy Iron Gate Valves	74-82
T-174-A/T-174-SS	17	Illustrated Index	74
T-176-A/T-176-SS	18	F-617-13	75, 76
Bronze Globe Valves	19-24	F-637-31	77, 78
Illustrated Index	19	F-637-33	79, 80
T/S-211	20	F-639-31	81
T/S-235	21	F-639-33	82
T-256-AP	22	Ductile and Alloy Iron Globe,	
T-275	23	Angle and Check Valves	83-92
T-276-AP	24	Illustrated Index	83
Bronze Angle Valves	25-29	F-738-31	84
Illustrated Index	25	F-838-31	85
T/S-311	26	F-918-13	86
T-335	27	F-938-31	87
T-375	28	F-938-33	88
T-376-AP	29	Why Ductile Iron?	89
Bronze Check Valves	30-36	Compare Ductile Iron to Cast Iron and Cast Steel	90
Illustrated Index	30	Construction Features Ductile Iron	91
T/S-413	31	Ductile Iron Valve Specifications	92
T/S-433	32	Valve Options for Bronze and Iron	93-103
S-433 (Bolted Bonnet)	33	Index	93
T-453	34	Bronze Handle Options and Diameters	94
T-473	35	Bronze Seating and Packing Material	95
T/S-480	36	Bronze Stem Ext./Oxygen Svc./Drain Cap/Silicone Lubricants	96
Bronze Y-Strainers	37	Iron Seating, Packing and Gasket Material	97
T/S-221/222	37	Iron Sprockets, Position Indicator and SON	98
Iron Gate Valves	38-52	Iron Stem Extensions	99
Illustrated Index	38	Iron Floor Stands	100
F/T-617-O	39, 40	Iron Bosses, By-Passes and Tapping	101
F-617-ON	41, 42	Iron Lever, Spring and Weight, Silicone Lubricants	102
F/T-619	43	Parts for Iron Lever, Spring and Weight, Gear Operators	103
F/T-619-N	44	Engineering Data	103-120
F-607-RWS	45	Index	103
F-619-RWS	46	Reference Specifications	105
MJ-619-RWS	47	Properties of Valve Materials (Table)	106, 107
P-619-RW	48	Properties of Valve Materials (Table)	108, 109
PCR-619-RW	49	Flow Data Cv Values for Valves (Table)	110, 111
FPCR-619-RW	50	Valve Terms and Piping Symbols	112
F-667-O	51	Marine Applications	113
F-669	52	Temperature Limits of Materials	114
Iron Globe and Angle Valves	53-60	Valve Installation Tips	115
Illustrated Index	53	Flange Dimensions	116, 117
F-718	54	Steam Tables	118
F-718-N	55	Bronze Figure Number Comparisons	119
F-768	56	Iron Figure Number Comparisons	120
F-818	57	Warranty	122
F-869	58		
Sizing F-869 Stop Check	59-61		

Visit our website for the most current information.

Pressure Rated Bronze, Iron and Ductile Iron Valves









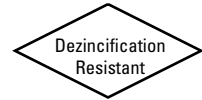

Gate, Globe, Angle and Check Valve Figure Number System							
Examples:							
	1 End	2 Type	3 Pressure	4 Detail-Features	5 Disc Material	6 Misc.	
T-113	T	1	1	3			
F-617-0	F	6	1	7		0	
Key:			4 Detail-Features			5 Disc Material	6 Miscellaneous
1 End	2 Type	3 Pressure	Gate	Globe and Angle	Check		
F-Flanged	1-Gate-Bronze	1-125# SWP/ 200#CWP	1-SB, RS, Solid	1-SB, Int	3-Hor SW, SB, Int (Y-Pat)	A-Alloy Threads	13-3% Nickel Body 31-Bronze 33-Stainless Steel
MJ-Mechanical Joint	2-Globe-Bronze	2-125# SWP/ 200# CWP	2-SB, RS	5-UB, Int	6-UB, Ren	B-Bronze	BHW-Bronze Handwheel BP-British Parallel BT-British Taper Threads
S-Solder	3-Angle-Bronze	3-150# SWP/ 300# or 285# CWP	3-SB, NRS, Solid	6-UB, Ren		V-FKM	B7-B7 Bolting C-Copper Flared D-Drain
T-Threaded	4-Check-Bronze		4-UB, RS, Solid	8-BB, Ren	8-Hor, SW, BB, Ren	W-Buna-N	GP-Graphite Packing GO-Gear Operator H-Hose End
W-Wafer	6-Gate-Iron Body	5-200# SWP/ 400# CWP	5-UB, RS, Split	9-BB, Ren Stop Check	0-Vert Lift, Ren Silent Type	Y-PTFE	HC-Hose Cap and Chain K-Cross Handle L-Lockshield
P-IPS Push-on	7-Globe-Iron Body	6-250# SWP/ 500# CWP	6-UB, NRS, Solid				L&W-Lever and Weight L&S-Lever and Spring N-Iron Trim
PR-IPS Push-on w/Joint Restraint	8-Angle-Iron Body	7-300# SWP/ 600# CWP	7-BB, RS, Solid				O-OS&Y P-Full Plug Disc RW-Resilient Wedge
G-Grooved	9-Check-Iron Body	8-250# CWP 9-300# CWP 0-175# WWP	9-BB, NRS, Solid				SON-Square Operating Nut SS-Stainless Steel Trim T-Solid Tee Handle TP-PTFE Packing X-Oxygen Service Z-By-Pass
Terms:		CI Cast Iron	POA Price on Application	SB Screw-in Bonnet			
BB Bolted Bonnet	MI Malleable Iron	Ren Renewable	UB Union Bonnet				
Int Integral	NRS Non-Rising Stem	RS Rising Stem	FF Flat Face Flanges				
 <p>De-alloying corrosion, known as "Dezincification," was effectively eradicated from valve products in the 1950s. Today, however, this problem has returned with the increased use of high-zinc alloys (commonly referred to as 'Yellow Brass') in forged and cast valves typically produced outside the United States.</p> <p>Dezincification selectively removes zinc from the alloy, leaving behind a porous, copper-rich structure that has little mechanical strength. The physical attributes of an in-service valve with dezincification includes a white powdery substance or mineral stains on its exterior surface.</p> <p>What's the cure? On all bronze valves the metal components in the waterway must not contain more than 15% zinc in their chemical makeup. As a standard NIBCO bronze pressure-rated valves are made to be "Dezincification Resistant," which is a seal of quality and longevity.</p>							

This key is a guide only and is not intended to infer that any valve will be produced that is contained in the key.

Visit our website for the most current information.

Bronze Gate Valves Illustrated Index



<p>Bronze Gate Valve Screw-in Bonnet 125 lb. SWP 200 lb. CWP</p>  <p>T or S-111 Rising Stem • Solid Wedge Sizes ¼" thru 3" Threaded or Solder Ends Page 6</p>	<p>Bronze Gate Valve Screw-in Bonnet 125 lb. SWP 200 lb. CWP</p>  <p>T or S-113 Non-Rising Stem • Solid Wedge Sizes ¼" thru 3" Threaded or Solder Ends Page 7</p>	<p>Bronze Hose Gate Valve Screw-in Bonnet 125 lb. SWP 200 lb. CWP</p>  <p>T-113-HC Non-Rising Stem • Solid Wedge Sizes ½" thru 1½" Threaded Ends Page 8</p>	<p>Bronze Gate Valve Union Bonnet 125 lb. SWP 200 lb. CWP</p>  <p>T-124 Rising Stem • Solid Wedge Sizes ¼" thru 3" Threaded Ends Page 9</p>
<p>Bronze Gate Valve Screw-in Bonnet 150 lb. SWP 300 lb. CWP</p>  <p>T-131 Rising Stem • Solid Wedge Sizes ¼" thru 3" Threaded Ends Page 10</p>	<p>Bronze Gate Valve Screw-in Bonnet 150 lb. SWP 300 lb. CWP</p>  <p>T-133 Non-Rising Stem • Solid Wedge Sizes ¼" thru 3" Threaded Ends Page 11</p>	<p>Bronze Gate Valve Union Bonnet 150 lb. SWP 300 lb. CWP</p>  <p>T or S-134 Rising Stem • Solid Wedge Sizes ¼" thru 3" Size 4" Bolted Bonnet Threaded or Solder Ends Page 12, 13</p>	<p>Bronze Gate Valve Union Bonnet 150 lb. SWP 300 lb. CWP</p>  <p>T or S-136 Non-Rising Stem • Solid Wedge Sizes ¼" thru 3" Size 4" Bolted Bonnet Threaded or Solder Ends Page 14, 15</p>
<p>Bronze Gate Valve Block Design • Union Bonnet 200 lb. SWP 400 lb. CWP</p>  <p>T-154-A Rising Stem • Solid Wedge Sizes ¼" thru 2" Threaded Ends Page 16</p>	<p>Bronze Gate Valve Block Design • Union Bonnet 300 lb. SWP 600 lb. CWP</p>  <p>T-174-A or SS Bronze or SS Seats Rising Stem • Solid Wedge Sizes ¼" thru 2" Threaded Ends Page 17</p>	<p>Bronze Gate Valve Block Design • Union Bonnet 300 lb. SWP 600 lb. CWP</p>  <p>T-176-A or SS Bronze or SS Seats Non-Rising Stem • Solid Wedge Sizes ¼" thru 2" Threaded Ends Page 18</p>	

Visit our website for the most current information.

Class 125 Bronze Gate Valves

Screw-in bonnet • rising stem • solid wedge

125 PSI/8.6 bar saturated steam to 353° F/178° C
200 PSI/13.8 bar non-shock cold working pressure

CONFORMS TO MSS SP-80

MATERIAL LIST

PART	SPECIFICATION
1. Handwheel Nut	300 Series Stainless Steel
2. Identification Plate	Aluminum
3. Handwheel	Malleable Iron ASTM A 47
4. Stem	Silicon Bronze ASTM B 371 Alloy C69400/C69430 or ASTM B 99 Alloy C65100
5. Packing Nut	Bronze ASTM B 62 or ASTM B584 Alloy C84400 or Brass ASTM B 16
6. Packing Gland	Bronze ASTM B 62 or ASTM B584 Alloy C84400 or Brass ASTM B16
7. Packing	Aramid Fibers with Graphite
8. Bonnet	Bronze ASTM B 62
9. Body	Bronze ASTM B 62
10. Wedge	Bronze ASTM B 62

DIMENSIONS—WEIGHTS—QUANTITIES

Size	Dimensions						T-111		S-111		Master Ctn. Qty.		
	In.	mm.	In.	mm.	In.	mm.	Lbs.	Kg.	Lbs.	Kg.	T-111	S-111	
† ¼	8	1.69	43	4.63	117	x	x	0.79	0.36	x	x	50	x
† ⅜	10	1.69	43	4.63	117	.69	18	0.76	0.35	0.70	0.32	50	50
† ½	15	1.94	49	4.81	122	.75	19	0.87	0.40	0.73	0.33	50	50
¾	20	2.06	54	5.81	148	.88	22	1.19	0.54	1.07	0.49	50	50
1	25	2.44	62	7.09	180	1.00	25	1.98	0.90	1.77	0.80	30	30
1¼	32	2.63	67	8.13	206	1.19	32	2.66	1.21	2.52	1.14	20	20
1½	40	2.88	72	9.81	249	1.25	33	3.76	1.70	3.42	1.55	10	10
2	50	3.06	78	11.56	294	1.31	34	5.56	2.52	5.23	2.37	10	10
2½	65	4.13	105	14.31	364	1.81	46	10.81	4.90	9.63	4.37	4	4
3	80	4.50	114	16.50	419	1.94	49	15.49	7.02	13.92	6.31	2	4

† No packing gland, packing only in these sizes.
x Not available this size.

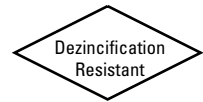

T-111
Threaded



S-111
Solder

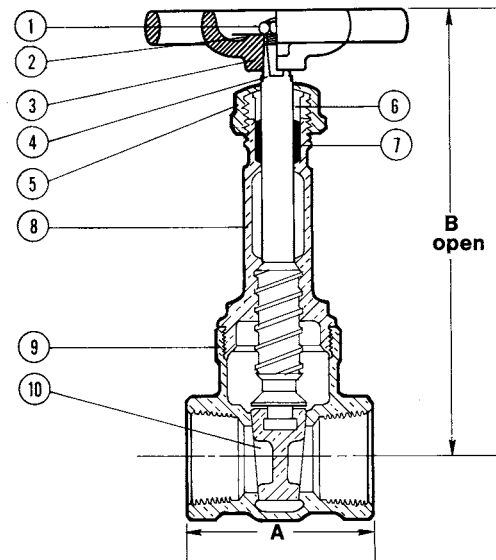

T-111
NPT x NPT

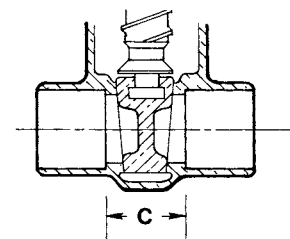

S-111
C x C

FREEZING WEATHER PRECAUTION: Subsequent to testing a piping system, valves should be left in an open position to allow complete drainage.

◆ For detailed Operating Pressure, refer to Pressure Temperature Chart on page 114.

Visit our website for the most current information.

Class 125 Bronze Gate Valves

Screw-in bonnet • non-rising stem • solid wedge

125 PSI/8.6 bar saturated steam to 353°F/178°C
200 PSI/13.8 bar non-shock cold working pressure

CONFORMS TO MSS SP-80

MATERIAL LIST

PART	SPECIFICATION
1. Handwheel Nut	300 Series Stainless Steel
2. Identification Plate	Aluminum
3. Handwheel	a. Malleable Iron ASTM A 47 (T-113) b. Bronze (T-113-BHW) c. Bronze Cross (T-113-K)
4. Stem	Silicon Bronze ASTM B 371 Alloy C69400/C69430 or ASTM B99 Alloy C65100
5. Packing Nut	Bronze ASTM B 62 or ASTM B584 Alloy C84400 or Brass ASTM B 16
6. Packing Gland	Bronze ASTM B 62 or ASTM B584 Alloy C84400 or Brass ASTM B 16
7. Packing	Aramid Fibers with Graphite
8. Stuffing Box	Bronze ASTM B 62
9. Bonnet	Bronze ASTM B 62
10. Body	Bronze ASTM B 62
11. Wedge	Bronze ASTM B 62



T-113
Threaded

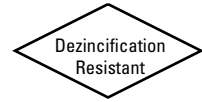

S-113
Solder

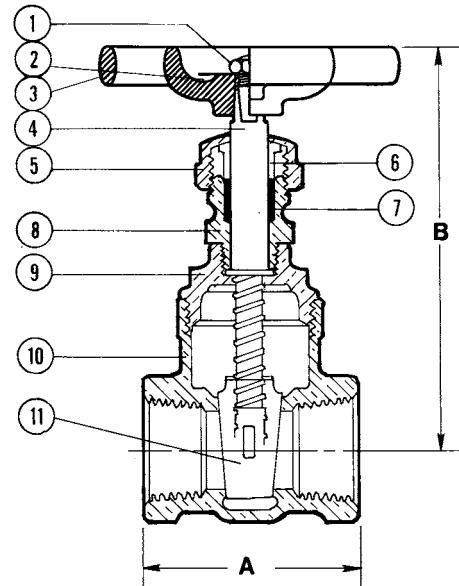

T-113
NPT x NPT

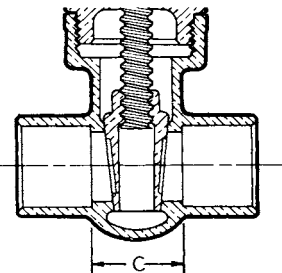

S-113
C x C

DIMENSIONS—WEIGHTS—QUANTITIES

Size	Dimensions						T-113		S-113		Master Ctn. Qty.	
	In.	mm.	In.	mm.	In.	mm.	Lbs.	Kg.	Lbs.	Kg.		
¼ †	8	1.69	43	3.38	86	x	x	0.74	0.33	x	x	50
⅜ †	10	1.69	43	3.38	86	.69	18	0.71	0.32	0.65	0.29	50
½ †	15	1.94	49	3.63	92	.75	19	0.82	0.37	0.67	0.31	50
¾	20	2.06	54	3.91	99	.88	22	1.10	0.50	0.99	0.45	50
1	25	2.44	62	4.69	119	1.00	25	1.82	0.82	1.60	0.72	30
1¼	32	2.63	67	5.22	133	1.19	32	2.40	1.09	2.25	1.02	20
1½	40	2.88	72	6.25	159	1.25	33	3.51	1.59	3.17	1.44	10
2	50	3.06	78	7.06	179	1.31	34	4.93	2.24	4.60	2.09	10
2½	65	4.13	105	8.41	224	1.81	46	9.96	4.52	8.78	3.98	5
3	80	4.50	114	10	254	1.94	49	14.40	6.53	12.84	5.82	4

†No packing gland, packing only in these sizes.
x = Not available this size.

FREEZING WEATHER PRECAUTION: Subsequent to testing a piping system, valves should be left in an open position to allow complete drainage.

◆For detailed Operating Pressure, refer to Pressure Temperature Chart on page 114.

Visit our website for the most current information.

Class 125 Bronze Gate Valves

Screw-in bonnet • non-rising stem • solid wedge

125 PSI/8.6 bar saturated steam to 353° F/178° C
200 PSI/13.8 bar non-shock cold working pressure

CONFORMS TO MSS SP-80

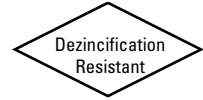

T-113-HC

Threaded x Hose Thread

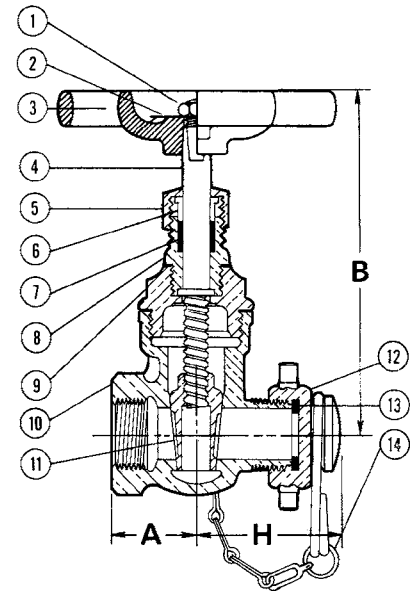

T-113-HC
NPT x ANFH

MATERIAL LIST

PART	SPECIFICATION
1. Handwheel Nut	300 Series Stainless Steel
2. Identification Plate	Aluminum
3. Handwheel	Malleable Iron ASTM A 47
4. Stem	Silicon Bronze ASTM B 371 Alloy C69400/C69430
5. Packing Nut	Sintered Bronze ASTM B 438 70 Grade I Type II or Brass ASTM B16
6. Packing Gland	Sintered Bronze ASTM B 438 70 Grade I Type II or Brass ASTM B16
7. Packing	Aramid Fibers with Graphite
8. Stuffing Box	Bronze ASTM B 62
9. Bonnet	Bronze ASTM B 62
10. Body	Bronze ASTM B 62
11. Wedge	Bronze ASTM B 62
*12. Hose Cap	Bronze ASTM B 62
13. Hose Cap Gasket	Rubber
14. Safety Chain	Brass

NOTE: Valve available less cap and chain – consult factory.

* ½ – 1 is 11½ threads per inch
1¼–1½ is 9 threads per inch

DIMENSIONS—WEIGHTS—QUANTITIES

Size		Dimensions				Weight		Master		
In.	mm.	In.	mm.	In.	mm.	In.	mm.	Lbs.	Kg.	Ctn. Qty.
½ x ¾H	15 x 20H†	1.13	29	4.44	113	2.06	52	1.52	0.69	30
¾ x ¾H	20 x 20H†	1.25	32	5.06	129	2.13	54	1.84	0.84	20
1 x 1H	25 x 25H*	1.44	37	5.88	149	2.38	60	2.93	1.33	20
1¼ x 1¼H	32 x 32H‡	1.56	40	6.63	168	2.75	70	4.27	1.94	10
1½ x 1½H	40 x 40H‡	1.69	43	7.09	180	2.94	75	5.75	2.61	10

† Garden Hose Thread

* Special Pitch Hose Thread

‡ American National Fire Hose Thread

FREEZING WEATHER PRECAUTION: Subsequent to testing a piping system, valves should be left in an open position to allow complete drainage.

◆ For detailed Operating Pressure, refer to Pressure Temperature Chart on page 114.

Visit our website for the most current information.

Class 125 Bronze Gate Valves

Union bonnet • rising stem • solid wedge

125 PSI/8.6 bar saturated steam to 353°F/178°C
200 PSI/13.8 bar non-shock cold working pressure

CONFORMS TO MSS SP-80

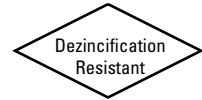

T-124
Threaded

MATERIAL LIST

PART	SPECIFICATION
1. Handwheel Nut	300 Series Stainless Steel
2. Identification Plate	Aluminum
3. Handwheel	Malleable Iron ASTM A 47
4. Stem	Silicon Bronze ASTM B 371 Alloy C69400/C69430 or ASTM B 99 Alloy C65100
5. Packing Nut	Bronze ASTM B 62 or ASTM B584 Alloy C84400 or Brass ASTM B 16
6. Packing Gland	Bronze ASTM B 62 or ASTM B584 Alloy C84400 or Brass ASTM B16
7. Packing	Aramid Fibers with Graphite
8. Bonnet	Bronze ASTM B 62
*9. Union Nut	Bronze ASTM B 62
10. Body	Bronze ASTM B 62
11. Wedge	Bronze ASTM B 62

*Sizes ¼", ⅜", ½" ASTM B 124 Alloy C37700.

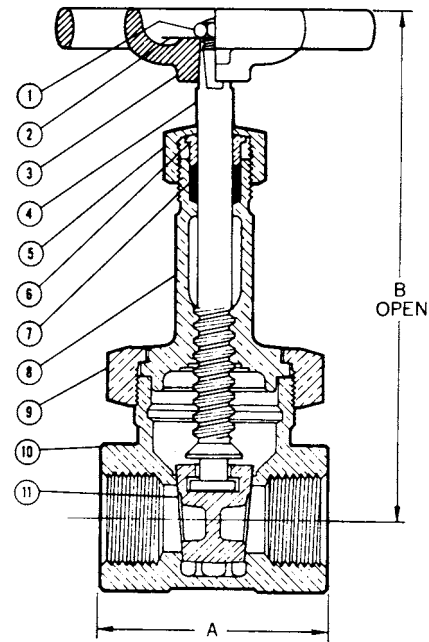

T-124
NPT x NPT

DIMENSIONS—WEIGHTS—QUANTITIES

Size	Dimensions				Weight		Master Ctn. Qty.	
	A		B		Lbs.	Kg.		
In.	mm.	In.	mm.	In.	mm.			
¼	8	1.96	60	4.81	122	1.08	0.49	50
⅜	10	1.96	50	4.81	122	1.12	0.51	50
½	15	2.31	59	4.81	122	1.16	0.53	40
¾	20	2.51	64	5.81	148	1.70	0.77	30
1	25	2.92	74	7.09	180	2.37	1.08	20
1¼	32	3.20	81	8.13	206	3.73	1.69	10
1½	40	3.33	85	9.81	249	4.67	2.12	10
2	50	3.44	87	11.56	294	7.77	3.53	6
2½	65	4.35	110	14.31	364	12.70	5.76	4
3	80	5.31	135	16.50	419	18.74	8.51	2

FREEZING WEATHER PRECAUTION: Subsequent to testing a piping system, valves should be left in an open position to allow complete drainage.

◆For detailed Operating Pressure, refer to Pressure Temperature Chart on page 114.

Visit our website for the most current information.

Class 150 Bronze Gate Valves

Screw-in bonnet • rising stem • solid wedge

150 PSI/10.3 bar saturated steam to 366° F/185° C
300 PSI/20.7 bar non-shock working pressure

CONFORMS TO MSS SP-80

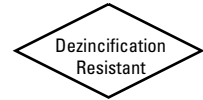

T-131
Threaded

MATERIAL LIST

PART	SPECIFICATION
1. Handwheel Nut	300 Series Stainless Steel
2. Identification Plate	Aluminum
3. Handwheel	Malleable Iron ASTM A 47
4. Stem	Silicon Bronze ASTM B 371 Alloy C69400/C69430 or ASTM B 99 Alloy C65100
5. Packing Nut	Bronze ASTM B 62 ASTM B584 Alloy C84400 or Brass ASTM B 16
6. Packing Gland	Bronze ASTM B 62 ASTM B584 Alloy C84400 or Brass ASTM B 16
7. Packing	Aramid Fibers with Graphite
8. Bonnet	Bronze ASTM B 62
9. Body	Bronze ASTM B 62
10. Wedge	Bronze ASTM B 62

DIMENSIONS—WEIGHTS—QUANTITIES

Size	Dimensions				Weight		Master Ctn. Qty.
	In.	mm.	In.	mm.	Lbs.	Kg.	
¼	8	1.96	50	4.81	1.01	0.46	50
⅜	10	1.96	50	4.81	1.04	0.47	50
½	15	2.31	59	4.81	1.06	0.48	40
¾	20	2.51	64	5.81	1.49	0.67	30
1	25	2.92	74	7.09	2.18	0.99	20
1¼	32	3.20	81	8.13	3.24	1.47	10
1½	40	3.33	86	9.81	4.57	2.07	10
2	50	3.44	87	11.56	7.67	3.48	6
2½	65	4.35	110	14.31	11.97	5.43	4
3	80	5.31	135	16.50	17.43	7.91	2

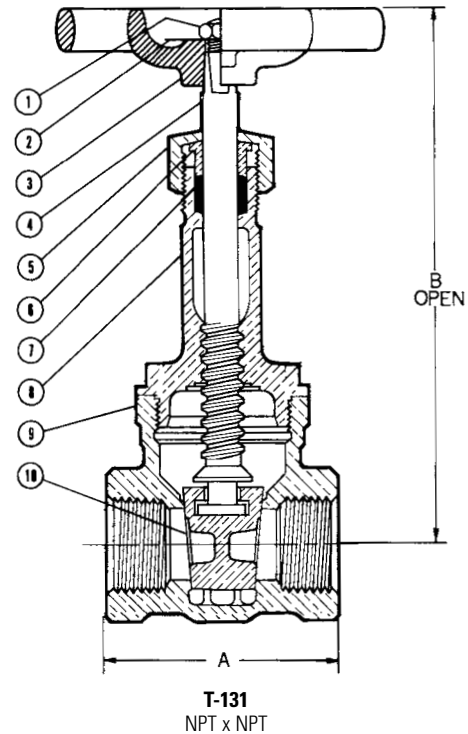

FREEZING WEATHER PRECAUTION: Subsequent to testing a piping system, valves should be left in an open position to allow complete drainage.

◆ For detailed Operating Pressure, refer to Pressure Temperature Chart on page 114.

Visit our website for the most current information.

Class 150 Bronze Gate Valves

Screw-in bonnet • non-rising stem • solid wedge

150 PSI/10.3 bar saturated steam to 366°F/185°C
300 PSI/20.7 bar non-shock cold working pressure

CONFORMS TO MSS SP-80

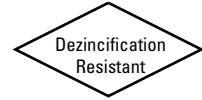

T-133
Threaded

MATERIAL LIST

PART	SPECIFICATION
1. Handwheel Nut	300 Series Stainless Steel
2. Identification Plate	Aluminum
3. Handwheel	Malleable Iron ASTM A 47
4. Stem	Silicon Bronze ASTM B 371 Alloy C69400/C69430 or ASTM B 99 Alloy C65100
5. Packing Nut	Bronze ASTM B 62 or ASTM B584 Alloy C84400 or Brass ASTM B 62
6. Packing Gland	Bronze ASTM B 62 or ASTM B584 Alloy C84400 or Brass ASTM B 16
7. Packing	Aramid Fibers with Graphite
8. Stuffing Box	Bronze ASTM B 62
9. Bonnet	Bronze ASTM B 62
10. Body	Bronze ASTM B 62
11. Wedge	Bronze ASTM B 62

DIMENSIONS—WEIGHTS—QUANTITIES

Dimensions

Size		A		B		Weight		Master
In.	mm.	In.	mm.	In.	mm.	Lbs.	Kg.	Ctn. Qty.
¼	8	1.96	50	3.63	92	1.02	0.46	50
⅜	10	1.96	50	3.63	92	1.05	0.48	50
½	15	2.31	59	3.63	92	0.93	0.42	40
¾	20	2.51	64	3.91	99	1.40	0.64	30
1	25	2.92	74	4.69	119	2.03	0.92	20
1¼	32	3.20	81	5.22	133	2.97	1.35	10
1½	40	3.33	86	6.25	159	4.16	1.89	10
2	50	3.44	87	7.06	179	6.75	3.07	6
2½	65	4.35	110	8.41	224	10.55	4.79	4
3	80	5.31	135	10.00	254	14.86	6.75	2

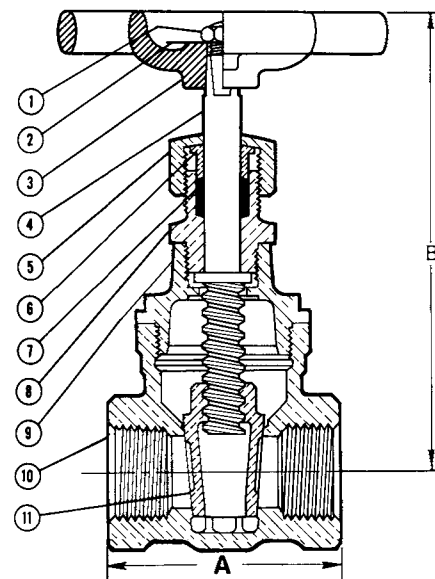

T-133
NPT x NPT

FREEZING WEATHER PRECAUTION: Subsequent to testing a piping system, valves should be left in an open position to allow complete drainage.

◆For detailed Operating Pressure, refer to Pressure Temperature Chart on page 114.

Visit our website for the most current information.

Class 150 Bronze Gate Valves

Union bonnet • rising stem • solid wedge

150 PSI/10.3 bar saturated steam to 366° F/185° C
300 PSI/20.7 bar non-shock cold working pressure

CONFORMS TO MSS SP-80

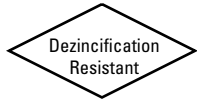

T-134
Threaded



S-134
Solder

MATERIAL LIST

PART	SPECIFICATION
1. Handwheel Nut	300 Series Stainless Steel
2. Identification Plate	Aluminum
3. Handwheel	Malleable Iron ASTM A 47
4. Stem	Silicon Bronze ASTM B 371 Alloy C69400/C69430 or ASTM B 99 Alloy C65100
5. Packing Nut	Bronze ASTM B 62 or ASTM B584 Alloy C84400 or Brass ASTM B16
6. Packing Gland	Bronze ASTM B 62 or ASTM B584 Alloy C84400 or Brass ASTM B 16
7. Packing	Aramid Fibers with Graphite
8. Bonnet	Bronze ASTM B 62
9. Union Nut	Bronze ASTM B 62
10. Body	Bronze ASTM B 62
11. Wedge	Bronze ASTM B 62

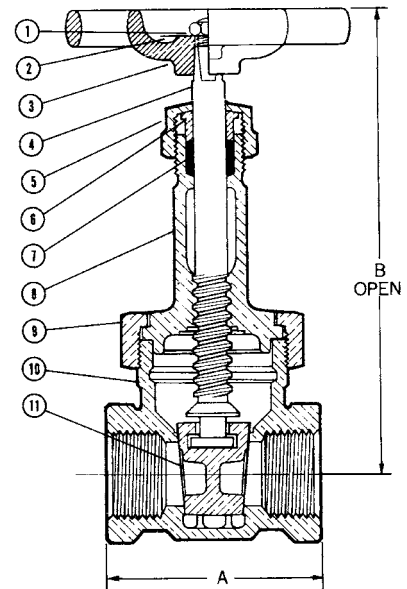

T-134
NPT x NPT

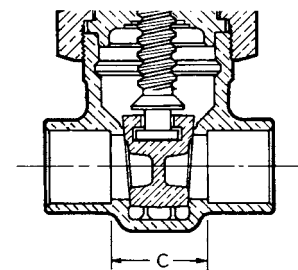

S-134
C x C

DIMENSIONS—WEIGHTS—QUANTITIES

Size	Dimensions						T-134		S-134		Master Ctn. Qty.	
	A		B		C		Lbs.	Kg.	Lbs.	Kg.		
In.	mm.	In.	mm.	In.	mm.	In.	mm.	Lbs.	Kg.	Lbs.	Kg.	
1/4	8	1.96	50	4.81	122	x	x	1.08	0.49	x	x	50
3/8	10	1.96	50	4.81	122	0.79	20	1.12	0.51	1.02	0.46	50
1/2	15	2.31	59	4.81	122	0.76	19	1.12	0.51	1.06	0.48	40
3/4	20	2.51	64	5.81	148	0.98	25	1.70	0.77	1.54	0.70	30
1	25	2.92	74	7.09	180	1.13	29	2.38	1.08	2.26	1.03	20
1 1/4	32	3.20	81	8.13	206	1.18	30	3.73	1.69	3.56	1.61	10
1 1/2	40	3.33	85	9.81	249	1.29	33	4.67	2.12	4.46	2.02	10
2	50	3.44	87	11.56	294	1.31	33	7.77	3.53	7.14	3.24	6
2 1/2	65	4.35	110	14.31	364	1.81	46	12.70	5.77	12.30	5.58	4
3	80	5.31	135	16.50	419	1.97	50	18.74	8.51	17.13	7.78	2

x Not available this size.

FREEZING WEATHER PRECAUTION: Subsequent to testing a piping system, valves should be left in an open position to allow complete drainage.

◆ For detailed Operating Pressure, refer to Pressure Temperature Chart on page 114.

Visit our website for the most current information.

Class 150 Bronze Gate Valves

Bolted bonnet • rising stem • solid wedge

150 PSI/10.3 bar saturated steam to 366°F/185°C
300 PSI/20.7 bar non-shock cold working pressure

CONFORMS TO MSS SP-80

MATERIAL LIST

PART	SPECIFICATION
1. Handwheel Nut	300 Series Stainless Steel
2. Identification Plate	Aluminum
3. Handwheel	Aluminum Commercial Alloy 380
4. Stem	Silicon Bronze ASTM B 371 Alloy C69400/C69430
5. Packing Nut	Bronze ASTM B 62 or ASTM B584 Alloy C84400 or Brass ASTM B 16
6. Packing Gland	Bronze ASTM B 62 or ASTM B584 Alloy C84400 or Brass ASTM B16
7. Packing	Aramid Fibers with Graphite
8. Bonnet	Bronze ASTM B 62
9. Bonnet Bolt	Zinc Plated Steel
10. Bonnet Gasket	Aramid Fibers with Graphite
11. Wedge	Bronze ASTM B 62
12. Body	Bronze ASTM B 62

DIMENSIONS—WEIGHTS—QUANTITIES

Size	Dimensions						T-134		S-134		Master Ctn. Qty	
	A		B		C		Lbs.	Kg.	Lbs.	Kg.		
In.	mm.	In.	mm.	In.	mm.	In.	mm.	Lbs.	Kg.	Lbs.	Kg.	
4	100	6.44	164	20.81	529	3.56	90	45.68	20.72	43.96	19.94	1

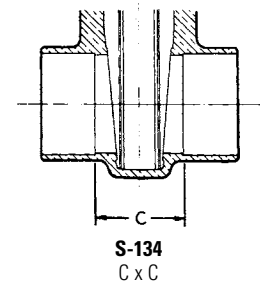
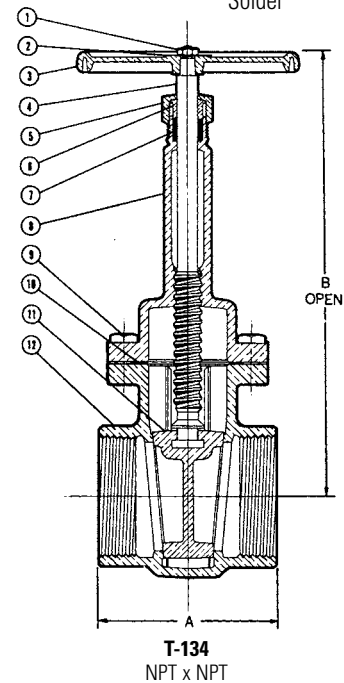
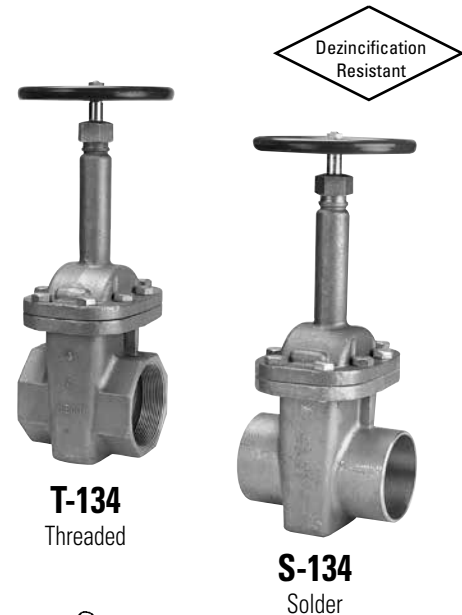

FREEZING WEATHER PRECAUTION: Subsequent to testing a piping system, valves should be left in an open position to allow complete drainage.

◆For detailed Operating Pressure, refer to Pressure Temperature Chart on page 114.

Visit our website for the most current information.

Class 150 Bronze Gate Valves

Union bonnet • non-rising stem • solid wedge

150 PSI/10.3 bar saturated steam to 366° F/185° C
300 PSI/20.7 bar non-shock cold working pressure

CONFORMS TO MSS SP-80

MATERIAL LIST

PART	SPECIFICATION
1. Handwheel Nut	300 Series Stainless Steel
2. Identification Plate	Aluminum
3. Handwheel	Malleable Iron ASTM A 47
4. Stem	Silicon Bronze ASTM B 371 Alloy C69400/C69430 or ASTM B 99 Alloy C65100
5. Packing Nut	Bronze ASTM B 62 or ASTM B584 Alloy C84400 or Brass ASTM B 16
6. Packing Gland	Bronze ASTM B 62 or ASTM B584 Alloy C84400 or Brass ASTM B16
7. Packing	Aramid Fibers with Graphite
8. Stuffing Box	Bronze ASTM B 62
9. Bonnet	Bronze ASTM B 62
10. Union Nut	Bronze ASTM B 62
11. Body	Bronze ASTM B 62
12. Wedge	Bronze ASTM B 62
13. Wedge Holder	Bronze ASTM B 62 (Not shown)



T-136
Threaded



S-136
Solder

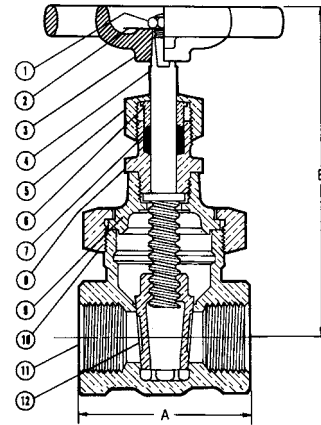
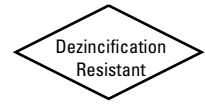

T-136
NPT x NPT

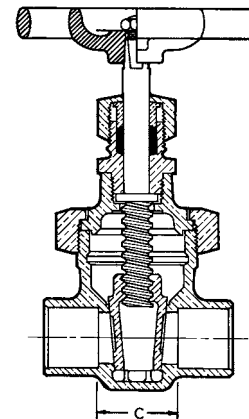

S-136
C x C

DIMENSIONS—WEIGHTS—QUANTITIES

Size	Dimensions						T-136		S-136		Master Ctn. Qty.	
	A		B		C		Lbs.	Kg.	Lbs.	Kg.		
In.	mm.	In.	mm.	In.	mm.	In.	mm.					
¼	8	1.96	50	3.63	92	x	x	1.09	0.50	x	x	50
⅜	10	1.96	50	3.63	92	0.79	20	1.07	0.48	1.02	0.46	50
½	15	2.31	59	3.63	92	0.76	19	1.12	0.51	1.02	0.46	40
¾	20	2.51	64	3.91	99	0.98	25	1.63	0.74	1.47	0.67	30
1	25	2.92	74	4.69	119	1.13	29	2.26	1.03	2.15	0.98	20
1¼	32	3.20	81	5.22	133	1.18	30	3.52	1.60	3.35	1.52	10
1½	40	3.33	86	6.25	159	1.29	34	4.44	2.01	4.22	1.92	10
2	50	3.44	87	7.06	179	1.31	33	7.35	3.34	6.72	3.05	6
2½	65	4.35	110	8.41	224	1.81	46	11.80	5.36	11.40	5.17	4
3	80	5.31	135	10.00	254	1.97	50	17.41	7.90	15.80	7.17	2

‡ Split Wedge with wedge holder.
x Not available this size.

FREEZING WEATHER PRECAUTION: Subsequent to testing a piping system, valves should be left in an open position to allow complete drainage.

◆ For detailed Operating Pressure, refer to Pressure Temperature Chart on page 114.

Visit our website for the most current information.

Class 150 Bronze Gate Valves

Bolted bonnet • non-rising stem • split wedge

150 PSI/10.3 bar saturated steam to 366°F/185°C

300 PSI/20.7 bar non-shock cold working pressure

CONFORMS TO MSS SP-80

MATERIAL LIST

PART	SPECIFICATION
1. Handwheel Nut	300 Series Stainless Steel
2. Identification Plate	Aluminum
3. Handwheel	Aluminum Commercial Alloy 380
4. Stem	Silicon Bronze ASTM B 371 Alloy C69400/C69430
5. Packing Nut	Bronze ASTM B 62 or ASTM B584 Alloy C84400 or Brass ASTM B16
6. Packing Gland	Bronze ASTM B 62 or ASTM B584 Alloy C84400 or Brass ASTM B 16
7. Packing	Aramid Fibers with Graphite
8. Stuffing Box	Bronze ASTM B 62
9. Bonnet	Bronze ASTM B 62
10. Bonnet Bolt	Zinc Plated Steel
11. Bonnet Gasket	Aramid Fibers with Graphite
12. Body	Bronze ASTM B 62
13. Wedge	Bronze ASTM B 62
14. Wedge Holder	Bronze ASTM B 62

DIMENSIONS—WEIGHTS—QUANTITIES

Size	Dimensions						T-136		S-136		Master Ctn. Qty.	
	A		B		C		Lbs.	Kg.	Lbs.	Kg.		
In.	mm.	In.	mm.	In.	mm.	In.	mm.	Lbs.	Kg.	Lbs.	Kg.	
4	100	6.44	164	12.25	311	3.56	90	43.85	19.89	42.13	19.13	1

NOTE: Split wedge with wedge holder.

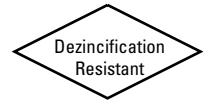

T-136
Threaded



S-136
Solder

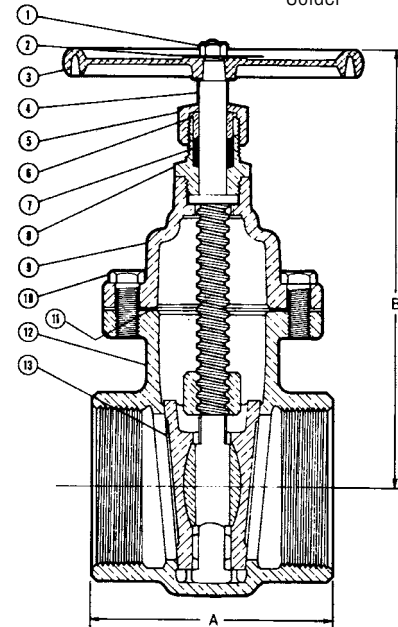

T-136
NPT x NPT

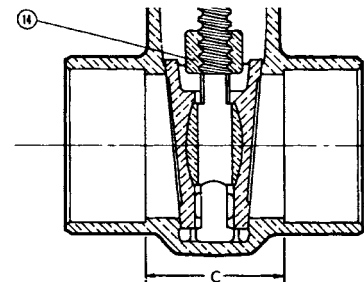

S-136
C x C

FREEZING WEATHER PRECAUTION: Subsequent to testing a piping system, valves should be left in an open position to allow complete drainage.

◆ For detailed Operating Pressure, refer to Pressure Temperature Chart on page 114.

Visit our website for the most current information.

Class 200 Bronze Gate Valves

Block pattern • union bonnet • rising stem • alloy solid wedge • integral seat

200 PSI/13.8 bar saturated steam to 391° F/201° C
400 PSI/27.6 bar non-shock cold working pressure

CONFORMS TO MSS SP-80

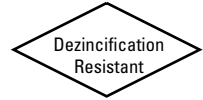

MATERIAL LIST

PART	SPECIFICATION
1. Handwheel Nut	300 Series Stainless Steel
2. Identification Plate	Aluminum
3. Handwheel	Malleable Iron ASTM A 47
4. Stem	Silicon Bronze ASTM B 371 Alloy C69400/C69430 or ASTM B 99 Alloy C65100
5. Packing Nut	Bronze ASTM B 62 or ASTM B584 Alloy C84400 or Brass ASTM B 16
6. Packing Gland	Bronze ASTM B 62 or ASTM B584 Alloy C84400 or Brass ASTM B16
7. Packing	Aramid Fibers with Graphite
8. Bonnet	Bronze ASTM B 61
9. Union Nut	Bronze ASTM B 61
10. Body	Bronze ASTM B 61
11. Wedge	ASTM B584 Alloy C97600



T-154-A
Threaded

DIMENSIONS—WEIGHTS—QUANTITIES

Size	Dimensions				Weight		Master Ctn. Qty.	
	A		B		Lbs.	Kg.		
In.	mm.	In.	mm.	In.	mm.			
¼	8	1.88	48	4.81	122	1.15	0.52	50
⅜	10	2.06	52	4.81	122	1.14	0.52	50
½	15	2.31	59	5.38	137	1.49	0.68	40
¾	20	2.44	62	6.31	160	2.23	1.01	30
1	25	2.88	73	7.56	192	3.37	1.53	20
1¼	32	3.13	83	8.88	226	4.76	2.16	10
1½	40	3.38	86	10.25	260	6.32	2.87	10
2	50	3.88	99	12.50	318	10.96	4.97	6

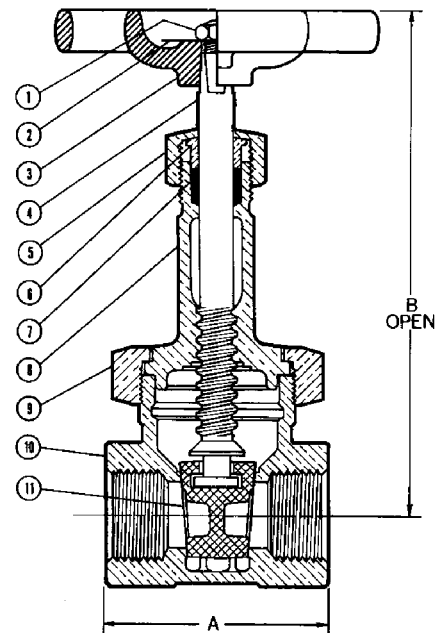

T-154-A
NPT x NPT
with Integral Seats

FREEZING WEATHER PRECAUTION: Subsequent to testing a piping system, valves should be left in an open position to allow complete drainage.

◆ For detailed Operating Pressure, refer to Pressure Temperature Chart on page 114.

Visit our website for the most current information.

Class 300 Bronze Gate Valves

Block pattern • union bonnet • rising stem • alloy solid wedge

300 PSI/20.7 bar saturated steam to 421°F/216°C

600 PSI/41.4 bar non-shock cold working pressure

CONFORMS TO MSS SP-80



**T-174-SS
T-174-A**
Threaded

MATERIAL LIST	
PART	SPECIFICATION
1. Handwheel Nut	300 Series Stainless Steel
2. Identification Plate	Aluminum
3. Handwheel	Malleable Iron ASTM A 47
4. Stem	Silicon Bronze ASTM B 371 Alloy C69400/C69430 or ASTM B 99 Alloy C65100
5. Packing Nut	Bronze ASTM B 62 or ASTM B584 Alloy C84400 or Brass ASTM B16
6. Packing Gland	Bronze ASTM B 62 or ASTM B584 Alloy C84400 or Brass ASTM B16
7. Packing	Aramid Fibers with Graphite
8. Bonnet	Bronze ASTM B 61
9. Union Nut	Bronze ASTM B 61
10. Body	Bronze ASTM B 61
11. Wedge	T-174-SS Bronze ASTM B 61 T-174-A Copper Nickel Alloy
12. Seats	T-174-SS Stainless Steel Type 410 ASTM A 276 Alloy 541000 T-174-A Integral with Body

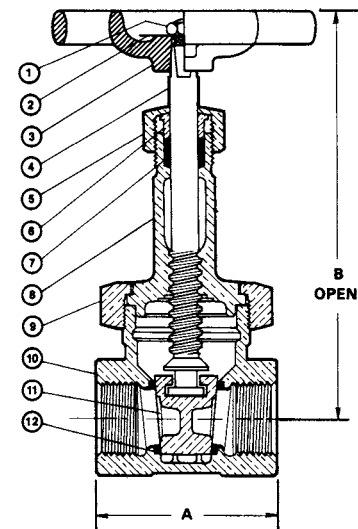

T-174-SS
NPT x NPT
with Stainless Steel Seats

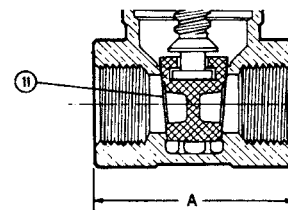

T-174-A
NPT x NPT
with Integral Seats

DIMENSIONS—WEIGHTS—QUANTITIES

Dimensions

Size	T-174-SS				T-174-A				T-174-SS		T-174-A		Master Ctn. Qty.	
	In.	mm.	In.	mm.	In.	mm.	In.	mm.	Lbs.	Kg.	Lbs.	Kg.		
1/4	8	x	x	x	x	1.88	48	4.81	122	x	x	1.15	0.52	50
3/8	10	x	x	x	x	2.06	53	4.81	122	x	x	1.14	0.52	50
1/2	15	2.38	60	5.38	137	2.31	59	5.38	137	1.48	0.67	1.49	0.68	40
3/4	20	2.69	68	6.31	160	2.44	62	6.31	160	2.23	1.01	2.23	1.01	30
1	25	3.13	79	7.56	192	2.88	73	7.56	192	3.37	1.53	3.37	1.53	20
1 1/4	32	3.44	87	8.88	226	3.13	79	8.75	222	4.74	2.15	4.76	2.16	10
1 1/2	40	3.75	95	10.25	260	3.38	86	10.25	260	6.29	2.85	6.32	2.87	10
2	50	4.25	108	12.50	318	3.88	99	12.50	318	10.84	4.92	10.96	4.97	6

x = Not available this size.

FREEZING WEATHER PRECAUTION: Subsequent to testing a piping system, valves should be left in an open position to allow complete drainage.

◆ For detailed Operating Pressure, refer to Pressure Temperature Chart on page 114.

Visit our website for the most current information.

Class 300 Bronze Gate Valves

Block pattern • union bonnet • non-rising stem • alloy solid wedge

300 PSI/20.7 bar saturated steam to 421° F/216° C
600 PSI/41.4 bar non-shock cold working pressure

CONFORMS TO MSS SP-80

MATERIAL LIST

PART	SPECIFICATION
1. Handwheel Nut	300 Series Stainless Steel
2. Identification Plate	Aluminum
3. Handwheel	Malleable Iron ASTM A 47
4. Stem	Silicon Bronze ASTM B 371 Alloy C69400/C69430 or ASTM B 99 Alloy C65100
5. Packing Nut	Bronze ASTM B 62 or ASTM B584 Alloy C84400 or Brass ASTM B 16
6. Packing Gland	Bronze ASTM B 62 or ASTM B584 Alloy C84400 or Brass ASTM B16
7. Packing	Aramid Fibers with Graphite
8. Stuffing Box	Bronze ASTM B 61
9. Bonnet	Bronze ASTM B 61
10. Union Nut	Bronze ASTM B 61
11. Body	Bronze ASTM B 61
12. Wedge	T-176-SS Bronze ASTM B 61 T-176-A Copper Nickel Alloy
13. Seats	T-176-SS Stainless Steel Type 410 ASTM A 276 Alloy 541000 T-176-A Integral with Body

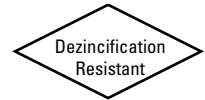

T-176-SS
T-176-A
Threaded

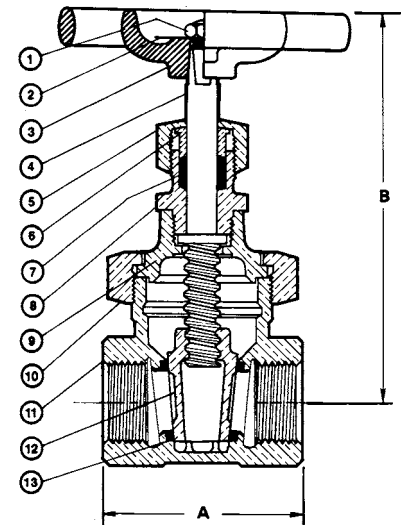

T-176-SS
NPT x NPT
with Stainless Steel Seats

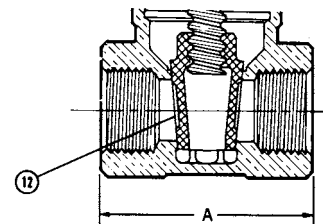

T-176-A
NPT x NPT
with Integral Seats

DIMENSIONS—WEIGHTS—QUANTITIES

Size	Dimensions								T-176-SS		T-176-A		Master Ctn.	Qty.
	T-176-SS				T-176-A				Lbs.	Kg.	Lbs.	Kg.		
	In.	mm.	In.	mm.	In.	mm.	In.	mm.						
1/4	8	x	x	x	x	1.88	48	3.88	98	x	x	1.15	0.52	50
3/8	10	x	x	x	x	2.06	53	3.88	98	x	x	1.14	0.52	50
1/2	15	2.38	60	4.19	106	2.31	59	4.31	106	1.44	0.65	1.44	0.65	40
3/4	20	2.69	68	4.63	117	2.44	62	4.63	117	2.15	0.98	2.13	0.97	30
1	25	3.13	79	5.44	138	2.88	73	5.44	138	3.25	1.47	3.24	1.47	20
1 1/4	32	3.44	87	6.06	154	3.13	79	6.06	154	4.56	2.07	4.57	2.07	10
1 1/2	40	3.75	95	7.13	181	3.38	86	7.13	181	6.02	2.73	5.98	2.71	10
2	50	4.25	108	8.31	211	3.88	99	8.31	211	10.46	4.74	10.18	4.62	6

x Not available this size.

FREEZING WEATHER PRECAUTION: Subsequent to testing a piping system, valves should be left in an open position to allow complete drainage.

◆ For detailed Operating Pressure, refer to Pressure Temperature Chart on page 114.

Visit our website for the most current information.

Bronze Globe Valves Illustrated Index

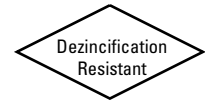

Bronze Globe Valve
Screw-in Bonnet
125 lb. SWP
200 lb. CWP



T or S-211-B or Y
Bronze or PTFE Disc
Sizes 1/8" thru 3"
Threaded or Solder Ends
Page 20

Bronze Globe Valve
Union Bonnet
150 lb. SWP
200 lb. CWP



T or S-235-Y
PTFE Disc
Sizes 1/8" thru 3"
Threaded or Solder Ends
Page 21

Bronze Globe Valve
Union Bonnet
200 lb. SWP
400 lb. CWP

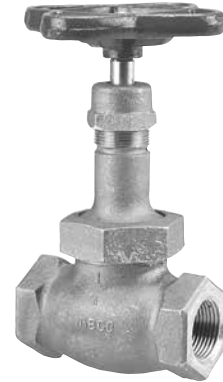

T-256-AP
Hardened Stainless Steel Full-plug Disc and Seat
Sizes 1/4" thru 3"
Threaded Ends
Page 22

Bronze Globe Valve
Union Bonnet
300 lb. SWP
600 lb. CWP



T-275-B or Y
Bronze or PTFE Disc
Sizes 1/4" thru 3"
Threaded Ends
Page 23

Bronze Globe Valve
Union Bonnet
300 lb. SWP
600 lb. CWP



T-276-AP
Hardened Stainless Steel Full-plug Disc and Seat
Sizes 1/4" thru 3"
Threaded Ends
Page 24

Visit our website for the most current information.

Class 125 Bronze Globe Valves

Screw-in bonnet • integral seat • renewable seat disc

125 PSI/8.6 bar saturated steam to 353° F/178° C
200 PSI/13.8 bar non-shock cold working pressure

CONFORMS TO MSS SP-80

MATERIAL LIST

PART	SPECIFICATION
1. Handwheel Nut	300 Series Stainless Steel
2. Identification Plate	Aluminum
3. Handwheel	Malleable Iron ASTM A 47
4. Stem	Silicon Bronze ASTM B 371 Alloy C69400/C69430
5. Packing Gland	Bronze ASTM B 62 or ASTM B584 Alloy C84400 or Brass ASTM B16
6. Packing Nut	Bronze ASTM B 62 or ASTM B584 Alloy C84400 or Brass ASTM B16
7. Packing	Aramid Fibers with Graphite
8. Bonnet	Bronze ASTM B 62
9. Disc Holder Nut	Bronze ASTM B 140 Alloy C31400 or B 62
*10. Disc Holder	Bronze ASTM B 62
*11. Seat Disc	Water, Oil or Gas Steam (PTFE) (Y)
*11a. Seat Disc	Bronze ASTM B 62 (B)
*12. Disc Nut	Bronze ASTM B 62/ASTM B 98 Alloy C65100 w/SS Washer
13. Body	Bronze ASTM B 62

Note: S-211 not available with (B) Disc.

* The Bronze Disc does not require a Disc Nut. When converting from (B) Disc to (Y) Disc, order Disc Nut (12) and Disc Holder (10) and proper disc (11).

DIMENSIONS—WEIGHTS—QUANTITIES

Size	Dimensions						T-211		S-211		Master Ctn. Qty.		
	In.	mm.	In.	mm.	In.	mm.	Lbs.	Kg.	Lbs.	Kg.	T-211	S-211	
* $\frac{1}{8}$ "†	6	2.38	60	3.38	86	1.81	46	1.01	0.46	0.98	0.44	50	50
* $\frac{1}{4}$ "†	8	2.38	60	3.38	86	1.81	46	1.00	0.45	0.94	0.43	50	50
* $\frac{3}{8}$ "†	10	2.38	60	3.38	86	1.81	46	0.98	0.45	0.93	0.42	50	50
* $\frac{1}{2}$ "†	15	2.56	65	3.38	86	1.69	43	1.03	0.47	0.95	0.43	50	50
$\frac{3}{4}$	20	3.06	78	4.88	124	2.25	57	1.73	0.79	1.80	0.82	30	30
1	25	3.69	94	5.69	145	2.81	72	2.85	1.29	2.87	1.30	20	20
1 $\frac{1}{4}$	32	4.31	110	6.13	156	3.06	78	3.79	1.72	3.55	1.61	10	10
1 $\frac{1}{2}$	40	4.69	119	7.38	187	3.56	91	5.90	2.68	5.70	2.58	10	10
2	50	5.63	143	7.94	202	4.44	113	8.68	3.94	8.91	4.04	6	4
2 $\frac{1}{2}$	65	6.63	168	10.19	259	5.25	133	15.40	6.98	15.92	7.22	2	2
3	80	7.75	197	11.19	284	6.50	165	22.44	10.18	21.32	9.67	2	2

* Stem and Disc (or Disc Holder) are integral.

† No packing gland, packing only in these sizes.



T-211
Threaded



S-211
Solder

Dezincification
Resistant

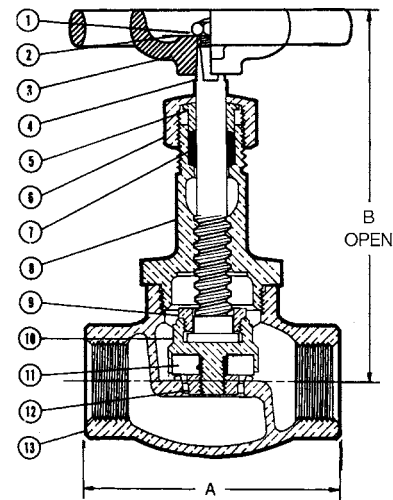

T-211-Y
NPT x NPT

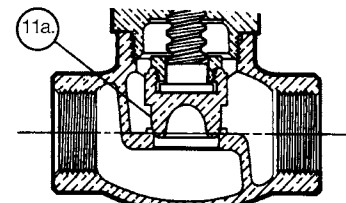

T-211-B
NPT x NPT

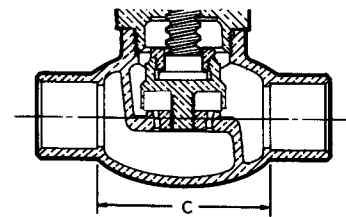

S-211-Y
C x C

FREEZING WEATHER PRECAUTION: Subsequent to testing a piping system, valves should be left in an open position to allow complete drainage.

◆ For detailed Operating Pressure, refer to Pressure Temperature Chart on page 114.

Visit our website for the most current information.

Class 150 Bronze Globe Valves

Union bonnet • integral seat • renewable seat disc

150 PSI/10.3 bar saturated steam to 366°F/185°C

300 PSI/20.7 bar non-shock cold working pressure

CONFORMS TO MSS SP-80

MATERIAL LIST

PART	SPECIFICATION
1. Handwheel Nut	300 Series Stainless Steel
2. Identification Plate	Aluminum
3. Handwheel	Malleable Iron ASTM A 47
4. Stem	Silicon Bronze ASTM B 371 Alloy C69400/C69430
5. Packing Gland	Bronze ASTM B 62 or ASTM B584 Alloy C84400 or Brass ASTM B16
6. Packing Nut	Bronze ASTM B 62 or ASTM B584 Alloy C84400 or Brass ASTM B16
7. Packing	Aramid Fibers with Graphite
8. Bonnet	Bronze ASTM B 62
9. Union Nut	Bronze ASTM B 62
10. Body	Bronze ASTM B 62
11. Disc Holder	Bronze ASTM B 62
12. Disc	Steam (PTFE) (Y)
13. Disc Nut	Bronze ASTM B 62/ASTM B 98 Alloy C65100 w/SS Washer



T-235-Y
Threaded

S-235-Y
Solder

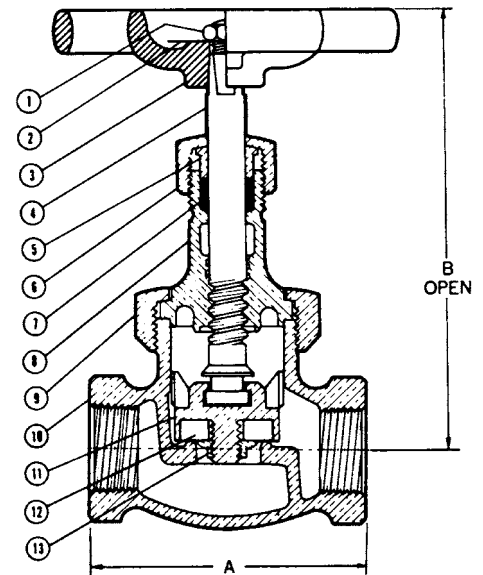

T-235-Y
NPT x NPT

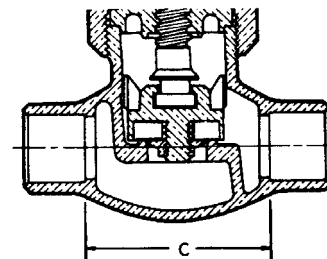

S-235-Y
C x C

DIMENSIONS—WEIGHTS—QUANTITIES

Size	Dimensions						T-235-Y		S-235-Y		Master Ctn. Qty.		
	In.	mm.	In.	mm.	In.	mm.	Lbs.	Kg.	Lbs.	Kg.	T-235-Y	S-235-Y	
† 1/8	6	2.31	59	3.88	99	2.00	51	1.21	0.55	1.06	0.48	50	50
† 1/4	8	2.31	59	3.88	99	1.88	48	1.19	0.54	1.05	0.48	50	50
† 3/8	10	2.38	60	3.88	99	1.75	45	1.17	0.53	1.03	0.47	50	50
1/2	15	2.69	68	4.63	118	1.88	48	1.60	0.73	1.38	0.62	40	50
3/4	20	3.19	81	5.38	137	2.31	59	2.34	1.06	2.21	1.00	20	20
1	25	3.75	95	6.00	153	2.88	73	3.56	1.61	3.35	1.52	10	20
1 1/4	32	4.25	108	6.56	167	3.13	79	5.76	2.61	4.93	2.23	10	10
1 1/2	40	4.75	121	7.38	187	3.75	95	7.59	3.44	7.17	3.25	6	10
2	50	5.75	146	8.31	211	4.50	114	12.56	5.70	11.02	5.00	4	4
2 1/2	65	6.63	168	10.19	259	5.38	137	17.44	7.91	17.16	7.79	2	2
3	80	7.75	197	11.13	283	6.50	165	23.87	10.83	22.82	10.35	2	2

†No packing gland, packing only in these sizes.

FREEZING WEATHER PRECAUTION: Subsequent to testing a piping system, valves should be left in an open position to allow complete drainage.

◆For detailed Operating Pressure, refer to Pressure Temperature Chart on page 114.

Visit our website for the most current information.

Class 200 Bronze Globe Valves

Union bonnet • replaceable seat and full plug disc

200 PSI/13.8 bar saturated steam to 391° F/201° C
400 PSI/27.6 bar non-shock cold working pressure

CONFORMS TO MSS SP-80

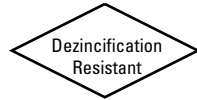

T-256-AP
Threaded

MATERIAL LIST

PART	SPECIFICATION
1. Handwheel Nut	300 Series Stainless Steel
2. Identification Plate	Aluminum
3. Handwheel	Malleable Iron ASTM A 47
4. Stem	Silicon Bronze ASTM B 371 Alloy C69400/C69430
5. Packing Gland	Bronze ASTM B 62 or ASTM B584 Alloy C84400 or Brass ASTM B16
6. Packing Nut	Bronze ASTM B 62 or ASTM B584 Alloy C84400 or Brass ASTM B 16
7. Packing	Aramid Fibers with Graphite
8. Bonnet	Bronze ASTM B 61
9. Union Nut	Bronze ASTM B 61
10. Body	Bronze ASTM B 61
11. Disc Holder Nut	Bronze ASTM B 61
12. Plug Disc	S42000 Stainless Steel ASTM A 276 Hardened
13. Plug Seat Ring	S42000 Stainless Steel ASTM A276 Hardened

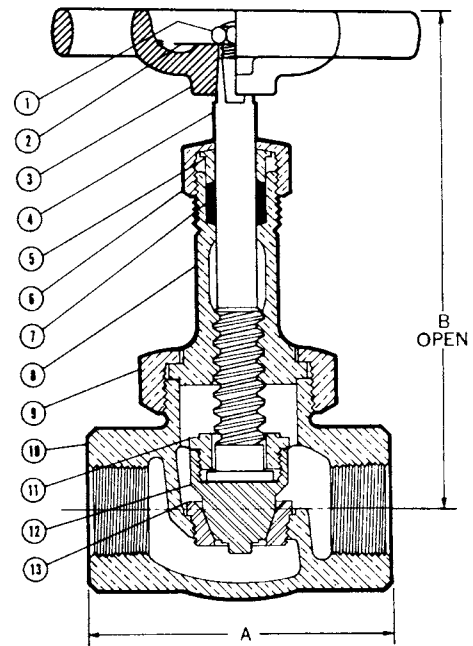

T-256-AP
NPT x NPT
Full Plug

DIMENSIONS—WEIGHTS—QUANTITIES

Size	Dimensions				Weight		Master Ctn. Qty.	
	A		B		Lbs.	Kg.		
In.	mm.	In.	mm.	In.	mm.			
† ¼	8	2.63	67	4.44	113	1.37	0.62	50
† ⅜	10	2.63	67	4.44	113	1.33	0.60	50
½	15	2.69	68	4.88	124	1.83	0.83	30
¾	20	3.38	86	5.75	146	2.76	1.25	20
1	25	4.00	102	7.00	178	4.71	2.13	10
1¼	32	4.63	118	7.63	194	6.61	3.00	10
1½	40	5.00	127	7.69	195	8.01	3.63	6
2	50	6.00	153	9.25	235	12.89	5.85	4
2½	65	6.63	168	10.19	259	17.74	8.04	2
3	80	7.75	197	11.125	283	24.55	11.13	2

† No packing gland, packing only in these sizes.

FREEZING WEATHER PRECAUTION: Subsequent to testing a piping system, valves should be left in an open position to allow complete drainage.

◆ For detailed Operating Pressure, refer to Pressure Temperature Chart on page 114.

Visit our website for the most current information.

Class 300 Bronze Globe Valves

Union bonnet • integral seat • renewable seat disc

300 PSI/20.7 bar saturated steam to 421°F/216°C
600 PSI/41.4 bar non-shock cold working pressure

CONFORMS TO MSS SP-80

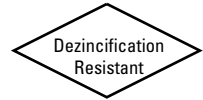

T-275
Threaded

MATERIAL LIST	
PART	SPECIFICATION
1. Handwheel Nut	300 Series Stainless Steel
2. Identification Plate	Aluminum
3. Handwheel	Malleable Iron ASTM A 47
4. Stem	Silicon Bronze ASTM B 371 Alloy C69400/C69430
5. Packing Gland	Bronze ASTM B 62 or ASTM B584 Alloy C84400 or Brass ASTM B16
6. Packing Nut	Bronze ASTM B 62 or ASTM B584 Alloy C84400 or Brass ASTM B16
7. Packing	Aramid Fibers with Graphite
8. Bonnet	Bronze ASTM B 61
9. Union Nut	Bronze ASTM B 61
10. Body	Bronze ASTM B 61
11. Disc Holder Nut	Bronze ASTM B 61
12. Seat Disc	Bronze ASTM B 61 (B)Steam (PTFE) (Y)
13. Seat Disc Nut	Bronze ASTM B 61 w/SS Washer
14. Disc Holder	Bronze ASTM B 62

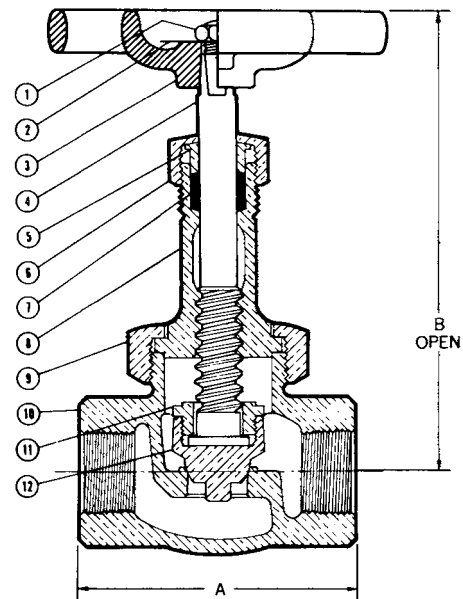

T-275-B
NPT x NPT
Semi-Plug

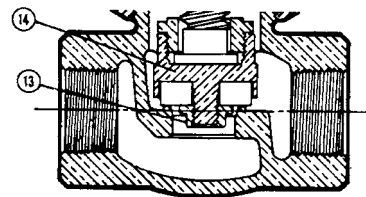

T-275-Y
NPT x NPT
Seat Disc

DIMENSIONS—WEIGHTS—QUANTITIES

Size	Dimensions				Weight		Master Ctn. Qty.	
	In.	mm.	In.	mm.	Lbs.	Kg.		
†1/8	6	2.63	67	4.44	113	1.38	0.62	50
†1/4	8	2.63	67	4.44	113	1.37	0.62	50
†3/8	10	2.63	67	4.44	113	1.32	0.60	50
1/2	15	2.69	68	4.88	124	1.82	0.83	30
3/4	20	3.38	86	5.75	146	2.84	1.29	20
1	25	4.00	102	7.00	178	4.80	2.18	10
1 1/4	32	4.63	118	7.63	194	7.03	3.19	10
1 1/2	40	5.00	127	7.69	195	8.34	3.78	6
2	50	6.00	153	9.25	235	13.65	6.19	4
2 1/2	65	6.63	168	10.19	259	17.39	7.89	2
3	80	7.75	197	11.13	283	23.69	10.75	2

†No packing gland, packing only in these sizes.

FREEZING WEATHER PRECAUTION: Subsequent to testing a piping system, valves should be left in an open position to allow complete drainage.

◆For detailed Operating Pressure, refer to Pressure Temperature Chart on page 114.

Visit our website for the most current information.

Class 300 Bronze Globe Valves

Union bonnet • replaceable seat and full plug disc

300 PSI/20.7 bar saturated steam to 421° F/216° C
600 PSI/41.4 bar non-shock cold working pressure

CONFORMS TO MSS SP-80

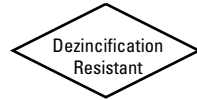

T-276-AP
Threaded

MATERIAL LIST

PART	SPECIFICATION
1. Handwheel Nut	300 Series Stainless Steel
2. Identification Plate	Aluminum
3. Handwheel	Malleable Iron ASTM A 47
4. Stem	Silicon Bronze ASTM B 371 Alloy C69400/C69430
5. Packing Gland	Bronze ASTM B 62 or ASTM B584 Alloy C84400 or Brass ASTM B16
6. Packing Nut	Bronze ASTM B 62 or ASTM B584 Alloy C84400 or Brass ASTM B 16
7. Packing	Aramid Fibers with Graphite
8. Bonnet	Bronze ASTM B 61
9. Union Nut	Bronze ASTM B 61
10. Body	Bronze ASTM B 61
11. Disc Holder Nut	Bronze ASTM B 61
12. Plug Disc	S42000 Stainless Steel ASTM A276 Hardened
13. Plug Seat Ring	S42000 Stainless Steel ASTM A276 Hardened

DIMENSIONS—WEIGHTS—QUANTITIES

Size	Dimensions				Weight		Master Ctn. Qty.	
	In.	mm.	In.	mm.	Lbs.	Kg.		
† ¼	8†	2.63	67	4.44	113	1.34	0.61	50
† ⅜	10†	2.63	67	4.44	113	1.35	0.61	50
½	15	2.69	68	4.88	124	1.82	0.83	30
¾	20	3.38	86	5.75	146	2.88	1.30	20
1	25	4.00	102	7.00	178	4.77	2.16	10
1¼	32	4.63	118	7.63	194	6.96	3.16	10
1½	40	5.00	127	7.69	195	8.41	3.81	6
2	50	6.00	153	9.25	235	13.41	6.08	4
2½	65	6.63	168	10.19	259	17.59	7.98	2
3	80	7.75	197	11.13	283	24.55	11.13	2

† No packing gland, packing only in these sizes.

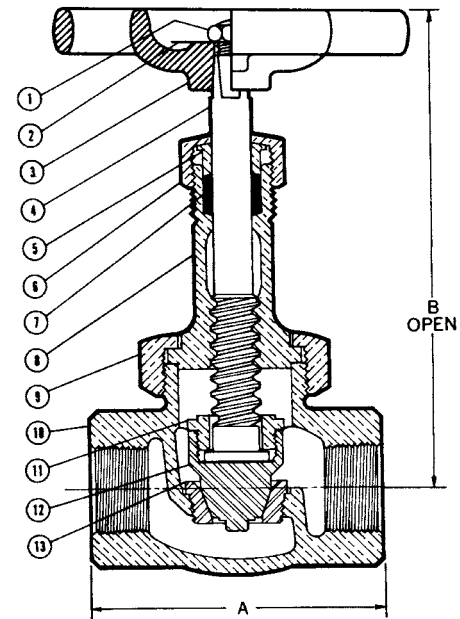

T-276-AP
NPT x NPT
Full Plug

FREEZING WEATHER PRECAUTION: Subsequent to testing a piping system, valves should be left in an open position to allow complete drainage.

◆ For detailed Operating Pressure, refer to Pressure Temperature Chart on page 114.

Visit our website for the most current information.

Bronze Angle Valves Illustrated Index

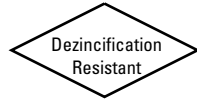

Bronze Angle Valve
Screw-in Bonnet
125 lb. SWP
200 lb. CWP



T or S-311-Y
PTFE Disc
Sizes 1/4" thru 3"
Threaded or Solder Ends
Page 26

Bronze Angle Valve
Union Bonnet
150 lb. SWP
300 lb. CWP



T-335-Y
PTFE Disc
Sizes 1/8" thru 3"
Threaded Ends
Page 27

Bronze Angle Valve
Union Bonnet
300 lb. SWP
600 lb. CWP



T-375-B or Y
Bronze or PTFE Disc
Sizes 1/4" thru 3"
Page 28

Bronze Angle Valve
Union Bonnet
300 lb. SWP
600 lb. CWP



T-376-AP
Hardened Stainless Steel Full-plug Disc and Seat
Sizes 1/4" thru 2"
Page 29

Visit our website for the most current information.

Class 125 Bronze Angle Valves

Screw-in bonnet • integral seat • renewable seat disc

125 PSI/8.6 bar saturated steam to 353° F/178° C
200 PSI/13.8 bar non-shock cold working pressure

CONFORMS TO MSS SP-80

MATERIAL LIST

PART	SPECIFICATION
1. Handwheel Nut	300 Series Stainless Steel
2. Identification Plate	Aluminum
3. Handwheel	Malleable Iron ASTM A 47
4. Stem	Silicon Bronze ASTM B 371 Alloy C69400/C69430
5. Packing Gland	Bronze ASTM B 62 or ASTM B584 Alloy C84400 or Brass ASTM B 16
6. Packing Nut	Bronze ASTM B 62 or ASTM B584 Alloy C84400 or Brass ASTM B 16
7. Packing	Aramid Fibers with Graphite
8. Bonnet	Bronze ASTM B 62
*9. Disc Holder Nut	Bronze ASTM B 62 or B 140 Alloy C31400
10. Disc Holder	Bronze ASTM B 62
11. Seat Disc	Steam (PTFE) (Y)
12. Seat Disc Nut	Bronze ASTM B 62 w/SS Washer
13. Body	Bronze ASTM B 62

* 2½" and 3" are ASTM B 61

DIMENSIONS—WEIGHTS—QUANTITIES

Size	Dimensions						T-311		S-311		Master Ctn. Qty.	
	In.	mm.	In.	mm.	In.	mm.	In.	mm.	Lbs.	Kg.		Lbs.
*¼	8	3.50	89	.94	24	1.19	30	0.98	0.44	0.82	0.37	50
*⅜	10	3.50	89	.88	22	1.19	30	0.93	0.42	0.82	0.37	50
*½	15	3.50	89	.88	22	1.31	33	1.01	0.46	0.95	0.43	30
¾	20	4.94	126	1.13	29	1.56	40	1.70	0.77	1.71	0.78	20
1	25	5.75	146	1.44	37	1.88	48	2.82	1.28	2.79	1.27	10
1¼	32	6.13	156	1.50	38	2.19	51	3.76	1.70	3.77	1.71	10
1½	40	7.25	179	1.75	45	2.38	60	5.79	2.63	4.70	2.13	6
2	50	8.13	206	2.16	55	2.81	72	8.76	3.97	8.73	3.96	4
2½	65	10.56	268	2.69	68	3.19	81	16.13	7.32	16.13	7.32	2
3	80	11.19	284	3.25	83	3.88	99	21.72	9.85	21.32	9.67	2

* Stem and Disc or Disc Holder are integral. No packing gland, packing only in these sizes.



T-311-Y
Threaded



S-311-Y
Solder

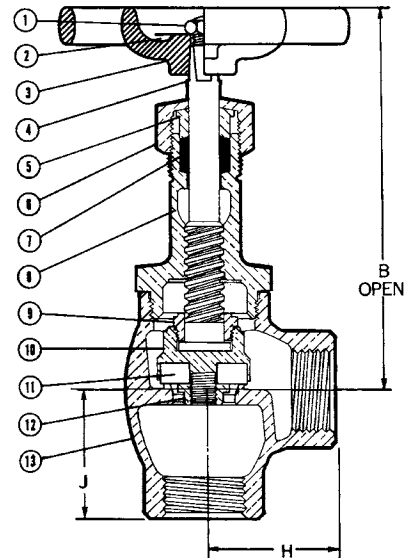
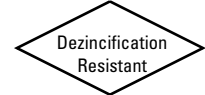

T-311-Y
NPT x NPT

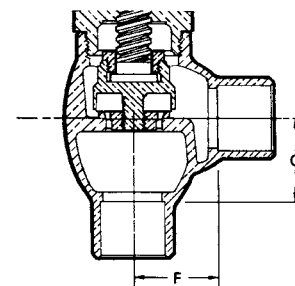

S-311-Y
C x C

FREEZING WEATHER PRECAUTION: Subsequent to testing a piping system, valves should be left in an open position to allow complete drainage.

◆ For detailed Operating Pressure, refer to Pressure Temperature Chart on page 114.

Visit our website for the most current information.

Class 150 Bronze Angle Valves

Union bonnet • integral seat • renewable seat disc

150 PSI/10.3 bar saturated steam to 366°F/185°C
300 PSI/20.7 bar non-shock cold working pressure

CONFORMS TO MSS SP-80

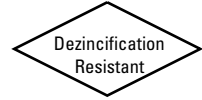

T-335-Y
Threaded

MATERIAL LIST

PART	SPECIFICATION
1. Handwheel Nut	300 Series Stainless Steel
2. Identification Plate	Aluminum
3. Handwheel	Malleable Iron ASTM A 47
4. Stem	Silicon Bronze ASTM B 371 Alloy C69400/C69430
5. Packing Gland	Bronze ASTM B 62 or ASTM B584 Alloy C84400 or Brass ASTM B16
6. Packing Nut	Bronze ASTM B 62 or ASTM B584 Alloy C84400 or Brass ASTM B16
7. Packing	Aramid Fibers with Graphite
8. Bonnet	Bronze ASTM B 62
9. Union Nut	Bronze ASTM B 62
10. Disc Holder	Bronze ASTM B 62
11. Seat Disc	Steam (PTFE) (Y)
12. Disc Nut	Bronze ASTM B 62 w/SS Washer
13. Body	Bronze ASTM B 62

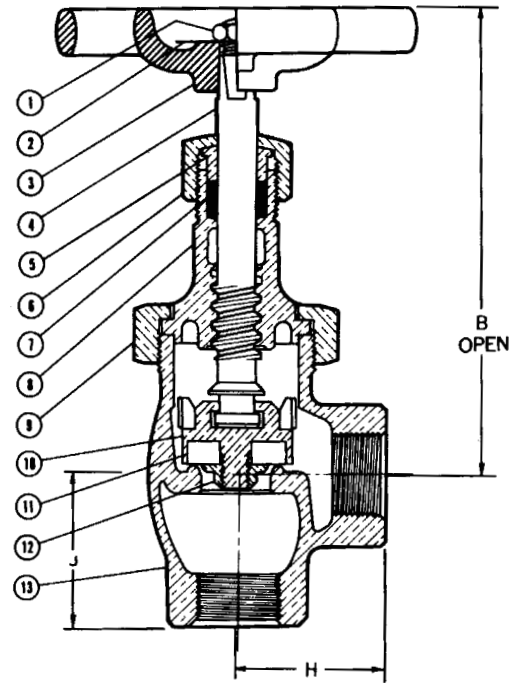

T-335-Y
NPT x NPT

DIMENSIONS—WEIGHTS—QUANTITIES

Size	Dimensions						Weight		Master Ctn. Qty.	
	H		B		J		Lbs.	Kg.		
In.	mm.	In.	mm.	In.	mm.	In.	mm.			
†1/8	6	1.19	30	3.88	99	1.19	30	1.17	0.53	50
†1/4	8	1.19	30	3.88	99	1.19	30	1.12	0.51	50
†3/8	10	1.19	30	3.88	99	1.19	30	1.10	0.50	50
1/2	15	1.31	33	4.44	113	1.31	33	1.39	0.63	50
3/4	20	1.56	40	5.38	137	1.56	40	2.32	1.05	20
1	25	1.88	48	6.00	153	1.88	48	3.52	1.60	20
1 1/4	32	2.13	54	3.56	167	2.13	54	5.18	2.35	10
1 1/2	40	2.38	60	7.25	179	2.38	60	7.58	3.44	6
2	50	2.88	73	8.31	211	2.88	73	11.83	5.37	4
2 1/2	65	3.31	85	10.19	259	3.31	85	17.71	8.03	4
3	80	3.88	99	11.19	284	3.88	99	24.49	11.11	2

†No packing gland, packing only in these sizes.

FREEZING WEATHER PRECAUTION: Subsequent to testing a piping system, valves should be left in an open position to allow complete drainage.

◆For detailed Operating Pressure, refer to Pressure Temperature Chart on page 114.

Visit our website for the most current information.

Class 300 Bronze Angle Valves

Union Bonnet • Integral Seat • Renewable Seat Disc

300 PSI/20.7 bar saturated steam to 421° F/216° C
600 PSI/41.4 bar non-shock cold working pressure

CONFORMS TO MSS SP-80

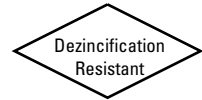

T-375-B
Threaded

MATERIAL LIST

PART	SPECIFICATION
1. Handwheel Nut	300 Series Stainless Steel
2. Identification Plate	Aluminum
3. Handwheel	Malleable Iron ASTM A 47
4. Stem	Silicon Bronze ASTM B 371 Alloy C69400/C69430
5. Packing Gland	Bronze ASTM B 62 or ASTM B584 Alloy C84400 or Brass ASTM B 16
6. Packing Nut	Bronze ASTM B 62 or ASTM B584 Alloy C84400 or Brass ASTM B 16
7. Packing	Aramid Fibers with Graphite
8. Bonnet	Bronze ASTM B 61
9. Union Nut	Bronze ASTM B 61
10. Disc Holder Nut	Bronze ASTM B 61
11. Seat Disc	Bronze ASTM B 61 (B) Steam (PTFE) (Y)
12. Body	Bronze ASTM B 61

DIMENSIONS—WEIGHTS—QUANTITIES

Size	Dimensions				Weight		Master Ctn. Qty.	
	B		H & J		Lbs.	Kg.		
In.	mm.	In.	mm.	In.	mm.			
† ¼	8	4.38	111	1.31	33	1.36	0.62	50
† ⅜	10	4.38	111	1.31	33	1.30	0.59	50
½	15	4.88	124	1.38	35	1.81	0.82	50
¾	20	5.75	146	1.69	43	2.78	1.26	20
1	25	7.00	178	2.00	51	4.54	2.06	10
1¼	32	7.63	194	2.31	59	6.88	3.12	10
1½	40	7.69	195	2.50	64	8.31	3.77	6
2	50	9.25	235	3.00	76	12.81	5.81	4
2½	65	10.13	257	3.31	84	16.86	7.65	4
3	80	11.13	283	3.88	98	22.76	10.32	2

† No packing gland, packing only in these sizes.

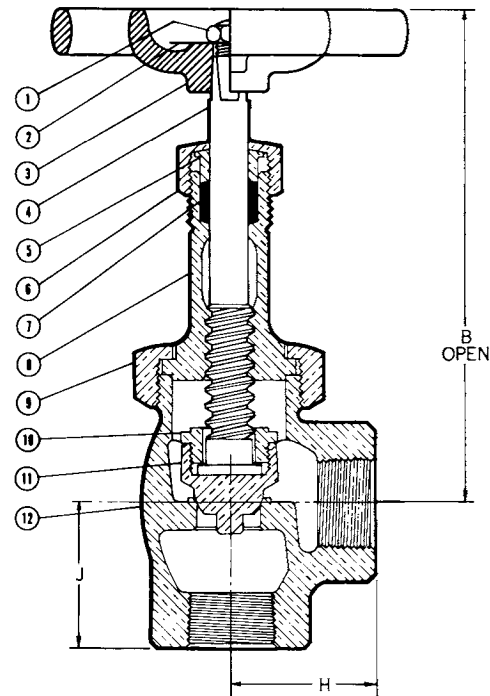

T-375-B
NPT x NPT

FREEZING WEATHER PRECAUTION: Subsequent to testing a piping system, valves should be left in an open position to allow complete drainage.

◆ For detailed Operating Pressure, refer to Pressure Temperature Chart on page 114.

Visit our website for the most current information.

Class 300 Bronze Angle Valves

Union bonnet • replaceable seat and full-plug disc

300 PSI/20.7 bar saturated steam to 421°F/216°C

600 PSI/41.4 bar non-shock cold working pressure

CONFORMS TO MSS SP-80

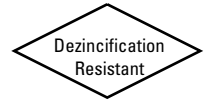

MATERIAL LIST

PART	SPECIFICATION
1. Handwheel Nut	300 Series Stainless Steel
2. Identification Plate	Aluminum
3. Handwheel	Malleable Iron ASTM A 47
4. Stem	Silicon Bronze ASTM B 371 Alloy C69400/C69430
5. Packing Gland	Bronze ASTM B 62 or ASTM B584 Alloy C84400 or Brass ASTM B16
6. Packing Nut	Bronze ASTM B 62 or ASTM B584 Alloy C84400 or Brass ASTM B16
7. Packing	Aramid Fibers with Graphite
8. Bonnet	Bronze ASTM B 61
9. Union Nut	Bronze ASTM B 61
10. Body	Bronze ASTM B 61
11. Disc Holder Nut	Bronze ASTM B 61
12. Plug Disc	S42000 Stainless Steel ASTM A 276 Hardened
13. Seat Ring	S42000 Stainless Steel ASTM A276 Hardened



T-376-AP
Threaded

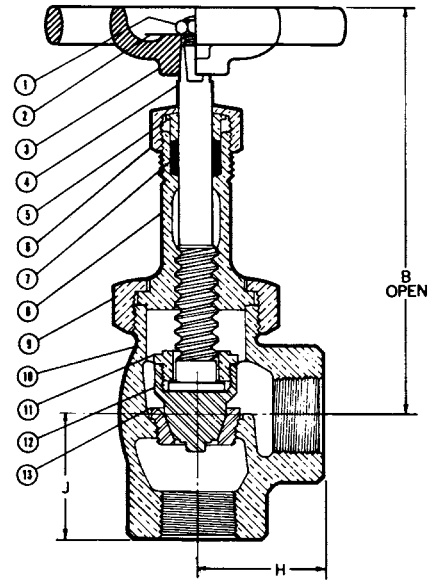

T-376-AP
NPT x NPT

DIMENSIONS—WEIGHTS—QUANTITIES

Size	Dimensions				Weight		Master Ctn. Qty.
	B		H & J		Lbs.	Kg.	
In. mm.	In.	mm.	In.	mm.			
†¼ 8	4.38	111	1.31	33	1.38	0.63	50
†⅜ 10	4.38	111	1.31	33	1.22	0.55	50
½ 15	4.88	124	1.38	35	1.81	0.82	25
¾ 20	5.75	146	1.69	43	2.78	1.26	20
1 25	7.00	178	2.00	51	4.62	2.10	10
1¼ 32	7.63	194	2.31	59	6.84	3.10	10
1½ 40	7.69	195	2.50	64	8.61	3.90	6
2 50	9.25	235	3.00	76	13.09	5.94	4

†No packing gland, packing only in these sizes.

FREEZING WEATHER PRECAUTION: Subsequent to testing a piping system, valves should be left in an open position to allow complete drainage.

◆For detailed Operating Pressure, refer to Pressure Temperature Chart on page 114.

Visit our website for the most current information.

Bronze Check Valves & Y-Strainers

Illustrated Index

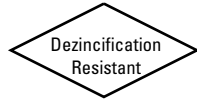

<p>Bronze Check Valve Horizontal Swing 125 lb. SWP 200 lb. CWP</p>  <p>T or S-413-B or V, W, Y Bronze or Various Non-Metallic Discs Regrinding Type • Y-Pattern Sizes 1/4" thru 3" Threaded or Solder Ends Page 31</p>	<p>Bronze Check Valve Horizontal Swing 150 lb. SWP 300 lb. CWP</p>  <p>T or S-433-B or Y Bronze or PTFE Discs Regrinding Type • Y-Pattern Sizes 1/4" thru 3" Threaded or Solder Ends Page 32</p>	<p>Bronze Check Valve Horizontal Swing 150 lb. SWP 300 lb. CWP</p>  <p>S-433-B Bronze Disc Regrinding Type • Bolted Bonnet Size 4" Solder Ends Page 33</p>	<p>Bronze Check Valve Horizontal Swing 200 lb. SWP 400 lb. CWP</p>  <p>T-453-B Bronze Disc Regrinding Type • Y-Pattern Sizes 1/4" thru 3" Threaded Ends Page 34</p>
<p>Bronze Check Valve Horizontal Swing 300 lb. SWP 600 lb. CWP</p>  <p>T-473-B or Y Bronze or PTFE Disc Regrinding Type • Y-Pattern Sizes 1/4" thru 2" Threaded Ends Page 35</p>	<p>Bronze Silent Check Valve Ring Check Design • Spring Actuated 125 lb. SWP, 250 lb. CWP (TFE Disc) 250 lb. SWP (Buna-N Disc)</p>  <p>T or S-480 Buna-N or PTFE Disc (Y-suffix) Sizes 3/8" thru 2" Threaded or Solder Ends Page 36</p>	<p>Bronze Y-Strainer Tapped Cap w/Blow-off Plug 125 lb. SWP 200 lb. CWP</p>  <p>T/S-221/222-A 304 SS 20 Mesh or Perforated Screen Sizes 1/4" thru 3" Threaded or Solder Ends Page 37</p>	<p>Bronze Y-Strainer Solid Cap 125 lb. SWP 200 lb. CWP</p>  <p>T/S-221/222-B 304 SS 20 Mesh or Perforated Screen Sizes 1/4" thru 3" Threaded or Solder Ends Page 37</p>

NOTE: Check valves should never be installed immediately adjacent to a pump discharge or change in direction. Check Valves should be installed downstream from all sources of line turbulence, including fittings and valves, at a minimum of 5x the nominal pipe diameter (preferably 10x) with straight piping to provide laminar flow.

Class 125 Bronze Check Valves

Horizontal swing • regrinding type • Y-pattern • renewable seat and disc

125 PSI/8.6 Bar Saturated Steam to 353°F/178°C
200 PSI/13.8 Bar Non-Shock Cold Working Pressure

CONFORMS TO MSS SP-80

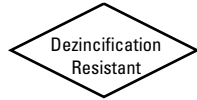

MATERIAL LIST

PART	SPECIFICATION
1. Bonnet	Bronze ASTM B 62
2. Body	Bronze ASTM B 62
3. Hinge Pin	Bronze ASTM B140 Alloy C31400 or B 134 Alloy C23000
4. Disc Hanger	Bronze ASTM B 62 or MPIF SS-316NI-25
5. Hanger Nut	Bronze ASTM B 16
6. Disc Holder	Bronze ASTM B 62
7. Seat Disc	Water, Oil or Gas (Buna-N) Steam (PTFE) (Y) Bronze ASTM (B) FKM (V) B 62 C83600
8. Seat Disc Nut	Bronze ASTM B 16 or B 62
9. Hinge Pin Plug	Bronze ASTM B140 Alloy C31400 (not shown)
10. Seat Disc Washer*	ASTM B 98 Alloy C65500 or ASTM B 103

*Sizes 3/4", 1", 1 1/4", 1 1/2" and 2" only.

DIMENSIONS—WEIGHTS—QUANTITIES

Size	Dimensions						T-413		S-413		Master Ctn. Qty.	
	A		B		C		Lbs.	Kg.	Lbs.	Kg.		
In.	mm.	In.	mm.	In.	mm.	In.	mm.	Lbs.	Kg.	Lbs.	Kg.	
1/4	8	2.13	54	1.63	41	1.38	35	0.50	0.23	0.51	0.23	50
3/8	10	2.13	54	1.63	41	1.31	33	0.47	0.22	0.48	0.22	50
1/2	15	2.44	62	1.69	43	1.50	38	0.55	0.25	0.55	0.25	50
3/4	20	2.94	75	1.88	48	1.88	48	0.90	0.41	0.88	0.40	10
1	25	3.56	90	2.31	59	2.25	57	1.46	0.66	1.48	0.67	5
1 1/4	32	4.19	106	2.69	68	2.75	70	2.17	0.99	2.22	1.01	20
1 1/2	40	4.50	114	2.94	75	3.11	79	2.95	1.34	3.00	1.36	10
2	50	5.25	133	3.94	100	3.75	95	4.79	2.17	4.87	2.21	10
2 1/2*	65	8.00	203	5.06	129	5.06	129	11.48	5.21	10.48	4.76	5
3*	80	9.25	235	6.25	159	6.25	159	17.53	7.96	15.29	6.94	4

Ordering: T-413 and S-413 normally furnished with Bronze Disc (T-413-B) or (S-413-B). Both available with PTFE Steam Disc (T-413-Y), (S-413-Y), or CWP Disc (T-413-W), (S-413-W) or 300° F 67 PSI steam FKM Disc (T-413-V).

*Class 150 (433) furnished for these sizes.

Install 5 pipe diameters minimum downstream from pump discharge or changes in direction to avoid flow turbulence. Flow straighteners may be required in extreme cases.

Note: On pump discharge, the preferred check valves are: inline, spring assisted, center-guided, lift checks.

NIBCO® Check Valves may be installed in both horizontal and vertical lines with upward flow or in any intermediate position. They will operate satisfactorily in a declining plane (no more than 15°).

Warning – Do Not Use For Reciprocating Air Compressor Service.



T-413
Threaded



S-413
Solder

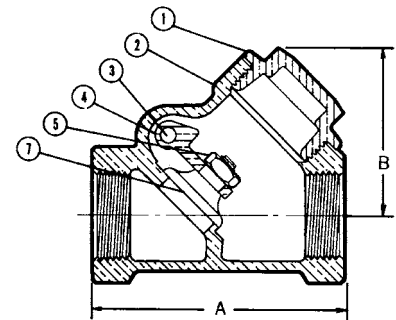

T-413-B
NPT x NPT

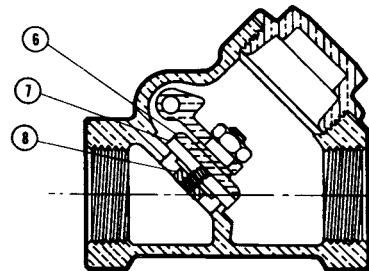

T-413-Y
NPT x NPT

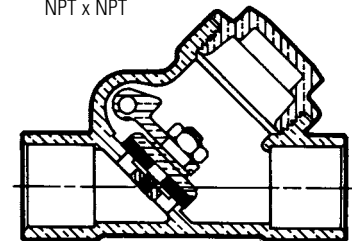

S-413-W
C x C

◆For detailed Operating Pressure, refer to Pressure Temperature Chart on page 114.

Visit our website for the most current information.

Class 150 Bronze Check Valves

Horizontal swing • regrinding type • Y-pattern • renewable seat and disc

150 PSI/10.3 bar saturated steam to 366° F/185° C
300 PSI/20.7 bar non-shock cold working pressure

CONFORMS TO MSS SP-80

MATERIAL LIST

PART	SPECIFICATION
1. Bonnet	Bronze ASTM B 62
2. Body	Bronze ASTM B 62
3. Hinge Pin	Bronze ASTM B 140 Alloy C31400 or B 134 Alloy C23000
4. Disc Hanger	Bronze ASTM B 62 or MPIF SS-316NI-25
5. Hanger Nut	Bronze ASTM B16
6. Disc Holder	Bronze ASTM B 62
7. Seat Disc	Steam (PTFE) (Y) Bronze ASTM B 62 C83600 (B)
8. Seat Disc Nut	Bronze ASTM B16 or B 62
9. Hinge Pin Plug	Bronze ASTM B 140 Alloy C31400 (not shown)
*10. Seat Disc Washer	ASTM B 98 Alloy C65500 or ASTM B 103

* Sizes ¾", 1", 1¼", 1½" and 2" only.

DIMENSIONS—WEIGHTS—QUANTITIES

Size	Dimensions								T-433		S-433		Master Ctn. Qty.	
	A		B		C		D		Lbs.	Kg.	Lbs.	Kg.		
In.	mm.	In.	mm.	In.	mm.	In.	mm.	In.	mm.	Lbs.	Kg.	Lbs.	Kg.	
¼	8	2.13	54	1.63	41	1.63	41	1.38	35	0.54	0.24	0.54	0.24	50
⅜	10	2.13	54	1.63	41	1.63	41	1.31	33	0.54	0.24	0.53	0.24	50
½	15	2.44	62	1.69	43	1.69	43	1.50	38	0.60	0.27	0.60	0.27	50
¾	20	2.94	75	1.88	48	1.88	48	1.88	48	0.98	0.44	0.99	0.45	50
1	25	3.56	90	2.31	59	2.31	59	2.25	57	1.58	0.72	1.57	0.71	30
1¼	32	4.19	106	2.69	68	2.69	68	2.75	70	2.39	1.08	2.34	1.06	20
1½	40	4.50	114	2.94	75	2.94	75	3.13	79	3.16	1.43	3.11	1.41	10
2	50	5.25	133	3.94	100	3.94	100	3.75	95	5.41	2.45	5.34	2.42	10
2½	65	8.00	203	5.06	129	5.06	129	5.31	135	11.48	5.21	11.20	5.08	5
3	80	9.25	235	6.25	159	6.25	159	6.25	159	17.53	7.95	16.91	7.67	4

Ordering: T-433 and S-433 normally furnished with Bronze Disc (T-433-B) or (S-433-B).
Both available with PTFE Steam Disc (T-433-Y), (S-433-Y).

Install 5 pipe diameters minimum downstream from pump discharge or changes in direction to avoid flow turbulence. Flow straighteners may be required in extreme cases.

Note: On pump discharge, the preferred check valves are:
- inline, spring assisted, center-guided, lift checks.

NIBCO® Check Valves may be installed in both horizontal and vertical lines with upward flow or in any intermediate position. They will operate satisfactorily in a declining plane (no more than 15°).

Warning – Do Not Use For Reciprocating Air Compressor Service.



T-433
Threaded

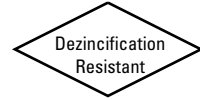

S-433
Solder

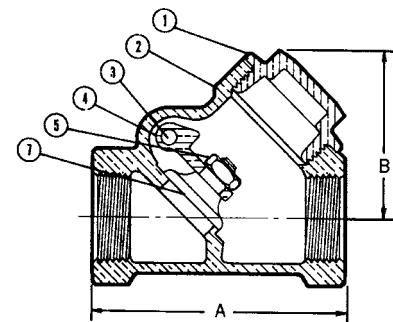

T-433-B
NPT x NPT

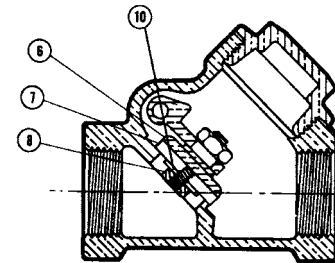

T-433-Y
NPT x NPT

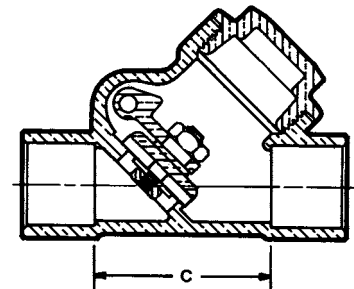

S-433-Y
C x C

◆ For detailed Operating Pressure, refer to Pressure Temperature Chart on page 114.

Visit our website for the most current information.

Class 150 Bronze Check Valves

Bolted bonnet • horizontal swing • regrinding type • renewable seat and disc

150 PSI/10.3 bar saturated steam to 366°F/185°C
300 PSI/20.7 bar non-shock cold working pressure

CONFORMS TO MSS SP-80

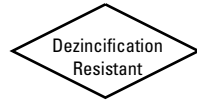

MATERIAL LIST

PART	SPECIFICATION
1. Bonnet	Bronze ASTM B 62
2. Body	Bronze ASTM B 62
3. Hinge Pin	ASTM B371 Alloy C69400
4. Disc Hanger	Bronze ASTM B 62 or MPIF SS-316NI-25
5. Hanger Nut	ASTM B 62 Alloy C83600
6. Disc	Bronze ASTM B 62 (B)
7. Hinge Pin Plug	Bronze ASTM B140 Alloy C31400
8. Seat Ring	Bronze ASTM B 62 C83600
9. Body Bolt	Zinc Plated Steel
10. Body Nut	Zinc Plated Steel
11. Gasket	Aramid Fibers with Graphite



S-433-B
Solder

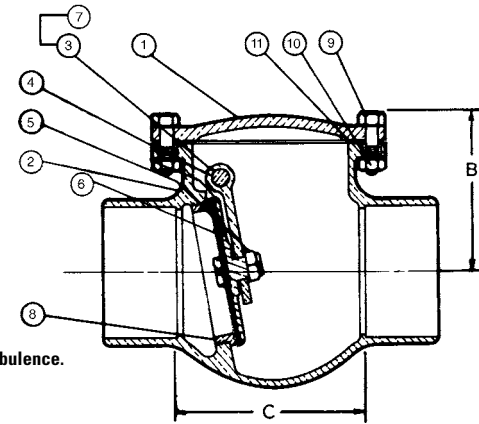

S-433-B
C x C

DIMENSIONS—WEIGHTS—QUANTITIES

Size	Dimensions				Weight		Master Ctn. Qty.	
	B		C		Lbs.	Kg.		
In.	mm.	In.	mm.	In.	mm.	Lbs.	Kg.	Ctn. Qty.
4	100	6.19	157	7.38	187	37	16.78	1

Install 5 pipe diameters minimum downstream from pump discharge or changes in direction to avoid flow turbulence. Flow straighteners may be required in extreme cases.

Note: On pump discharge, the preferred check valves are: inline, spring assisted, center-guided, lift checks.

NIBCO® Check Valves may be installed in both horizontal and vertical lines with upward flow or in any intermediate position. They will operate satisfactorily in a declining plane (no more than 15°).

Warning – Do Not Use For Reciprocating Air Compressor Service.

◆For detailed Operating Pressure, refer to Pressure Temperature Chart on page 114.

Visit our website for the most current information.

Class 200 Bronze Check Valves

Horizontal swing • regrinding type • renewable seat and disc • Y-pattern

200 PSI/13.8 bar saturated steam to 391° F/201° C
400 PSI/27.6 bar non-shock cold working pressure

CONFORMS TO MSS SP-80

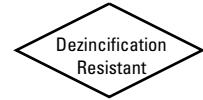

T-453-B
Threaded

MATERIAL LIST

PART	SPECIFICATION
1. Bonnet	Bronze ASTM B 61
2. Body	Bronze ASTM B 61
3. Hinge Pin	Bronze ASTM B 140 Alloy C31400 or B 134 Alloy C23000
4. Disc Hanger	Bronze ASTM B 61 or MPIF SS-316NI-25
5. Seat Disc	Bronze ASTM B 61 C92200
6. Hanger Nut	Bronze ASTM B 16 C31400
7. Hinge Pin Plug	ASTM B 140 Alloy C31600 (not shown)

DIMENSIONS—WEIGHTS—QUANTITIES

Size	Dimensions				Weight		Master Ctn.	Qty.
	A		B		Lbs.	Kg.		
In.	mm.	In.	mm.	In.	mm.			
¼	8	2.25	57	1.56	40	0.53	0.24	50
⅜	10	2.25	57	1.56	40	0.54	0.24	50
½	15	2.63	67	1.75	44	0.60	0.27	50
¾	20	3.13	79	2.06	52	0.99	0.45	25
1	25	3.75	95	2.44	62	1.56	0.71	30
1 ¼	32	4.38	111	3.13	79	2.33	1.06	10
1 ½	40	4.94	125	3.75	95	3.11	1.41	10
2	50	5.81	148	4.50	114	5.33	2.42	5
2 ½	65	8.00	203	5.31	135	13.72	6.22	5
3	80	9.25	235	6.25	159	17.64	8.00	4

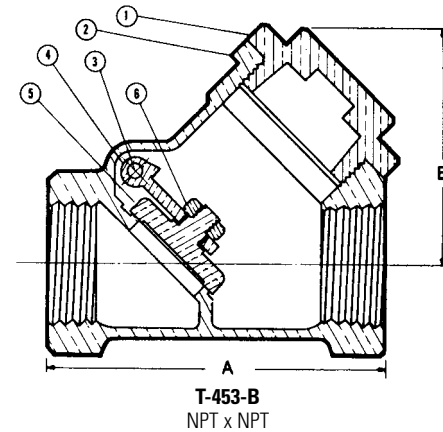

T-453-B
NPT x NPT

Install 5 pipe diameters minimum downstream from pump discharge or changes in direction to avoid flow turbulence. Flow straighteners may be required in extreme cases.

Note: On pump discharge, the preferred check valves are:
- inline, spring assisted, center-guided, lift checks.

NIBCO® Check Valves may be installed in both horizontal and vertical lines with upward flow or in any intermediate position. They will operate satisfactorily in a declining plane (no more than 15°).

Warning – Do Not Use For Reciprocating Air Compressor Service.

◆ For detailed Operating Pressure, refer to Pressure Temperature Chart on page 114.

Visit our website for the most current information.

Class 300 Bronze Check Valves

Horizontal swing • regrinding type • renewable seat and disc • Y-pattern

300 PSI/20.7 bar saturated steam to 421°F/216°C
600 PSI/41.4 bar non-shock cold working pressure

CONFORMS TO MSS SP-80

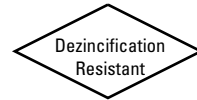

T-473
Threaded

MATERIAL LIST

PART	SPECIFICATION
1. Bonnet	Bronze ASTM B 61
2. Body	Bronze ASTM B 61
3. Hinge Pin	Bronze ASTM B 140 Alloy C31400 or B 134 Alloy C23000
4. Disc Hanger	Bronze ASTM B 61 or MPIF SS-316NI-25
5. Seat Disc	Bronze ASTM B 61 C92200 Steam (PTFE) (Y)
6. Hanger Nut	Bronze ASTM B16
7. Hinge Pin Plug	Bronze ASTM B 140 Alloy C31400 (not shown)
8. Disc Holder	Bronze ASTM B 61
9. Disc Nut	Bronze ASTM B 62 or B 16
*10. Seat Disc Washer	ASTM B 98 Alloy C65500 (not shown) or ASTM B 103 (not shown)

*Sizes 3/4", 1", 1 1/4", 1 1/2" and 2" only.

DIMENSIONS—WEIGHTS—QUANTITIES

Size	Dimensions				Weight	Master Ctn. Qty.	
	A		B				
In. mm.	In.	mm.	In.	mm.	Lbs.	Kg.	
1/4 8	2.25	57	1.56	40	0.57	0.26	50
3/8 10	2.25	57	1.56	40	0.57	0.26	50
1/2 15	2.63	67	1.75	44	0.69	0.31	50
3/4 20	3.13	79	2.06	52	1.02	0.46	25
1 25	3.75	95	2.44	62	1.65	0.75	30
1 1/4 32	4.38	111	3.13	79	2.98	1.35	10
1 1/2 40	4.94	125	3.75	95	4.81	2.18	10
2 50	5.81	148	4.50	114	8.13	3.69	5

Ordering: T-473 is normally furnished with Bronze Disc (T-473-B). Available with PTFE Steam Disc (T-473-Y).

Install 5 pipe diameters minimum downstream from pump discharge or changes in direction to avoid flow turbulence. Flow straighteners may be required in extreme cases.

Note: On pump discharge, the preferred check valves are:
- inline, spring assisted, center-guided, lift checks.

NIBCO® Check Valves may be installed in both horizontal and vertical lines with upward flow or in any intermediate position. They will operate satisfactorily in a declining plane (no more than 15°).

Warning – Do Not Use For Reciprocating Air Compressor Service.

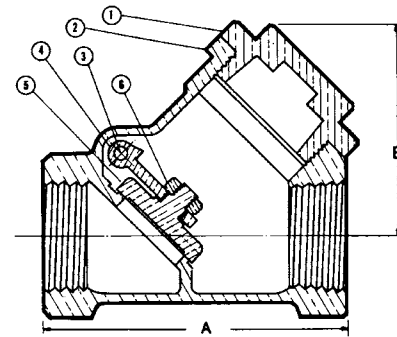

T-473-B
NPT x NPT

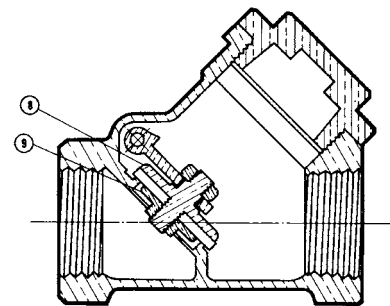

T-473-Y
NPT x NPT

◆For detailed Operating Pressure, refer to Pressure Temperature Chart on page 114.

Visit our website for the most current information.

Class 125 Bronze Ring Check® Valves

Inline lift type • resilient discs • spring actuated

125 PSI/8.6 bar saturated steam to 353° F/178° C (PTFE Disc)
250 PSI/17.2 bar non-shock cold working pressure

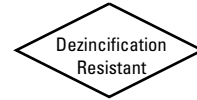

MATERIAL LIST

PART	SPECIFICATION
1. Body	Bronze ASTM B584 Alloy C84400
2. Stem	Stainless Steel ASTM A 582 Alloy C30300
3. Spring	316 Stainless Steel
4. Disc Holder	Stainless Steel Type 301
5. Disc	Water, Oil or Gas (Buna-N) Steam (PTFE) (Y)
6. Seat Screw	Stainless Steel ASTM A276 Alloy S43000
7. Body End	Bronze ASTM B584 Alloy C84400



T-480
Threaded



S-480
Solder

DIMENSIONS—WEIGHTS—QUANTITIES

Size	Dimensions						T-480		S-480		Master Ctn. Qty.	
	A		B		C		Lbs.	mm.	Lbs.	Kg.		
In.	mm.	In.	mm.	In.	mm.	In.	mm.	Lbs.	mm.	Lbs.	Kg.	
3/8	10	2.00	51	1.38	35	1.44	37	0.41	0.19	0.44	0.20	100
1/2	15	2.06	52	1.38	35	1.19	30	0.36	0.16	0.40	0.18	100
3/4	20	2.25	57	1.63	41	1.31	33	0.48	0.22	0.52	0.24	100
1	25	2.63	67	2.00	51	1.50	38	0.77	0.35	0.85	0.39	50
1 1/4	32	2.94	75	2.38	60	1.69	43	1.14	0.51	1.28	0.58	30
1 1/2	40	3.31	84	2.75	70	2.00	51	1.63	0.74	1.75	0.79	30
2	50	3.69	94	3.38	86	2.31	59	2.27	1.03	2.70	1.23	10

Ordering: The T-480 and S-480 both have standard Buna-N Discs.
Also available with PTFE (Y) Discs; specify T-480-Y or S-480-Y.
3/8" thru 2" require 1/2 pound pressure to open.

Install 5 pipe diameters minimum downstream from pump discharge or changes in direction to avoid flow turbulence. Flow straighteners may be required in extreme cases.

Note: On pump discharge, the preferred check valves are:
- inline, spring assisted, center-guided, lift checks.

NIBCO® Check Valves may be installed in both horizontal and vertical lines with upward flow or in any intermediate position.

Warning – Do Not Use For Reciprocating Air Compressor Service.

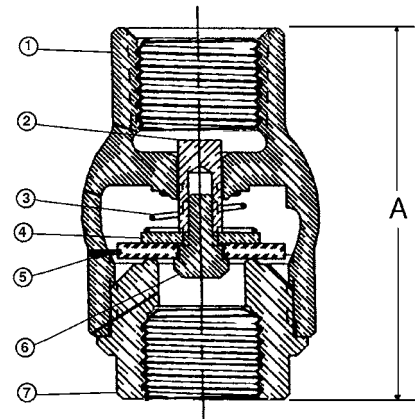

T-480-Y (PTFE Disc)
NPT x NPT

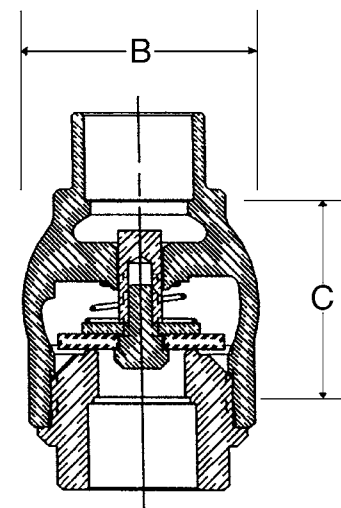

S-480-Y (PTFE Disc)
C x C

◆ For detailed Operating Pressure, refer to Pressure Temperature Chart on page 114.

Visit our website for the most current information.

Class 125 Bronze Y-Strainers

Screw-in cap • tapped cap w/ blow-off plug or solid cap •
20 mesh stainless steel screen or stainless steel perforated screen

125 PSI/8.6 bar saturated steam to 353°F/178°C
200 PSI/13.8 bar non-shock cold working pressure

CONFORMS TO ANSI B1.20.1 (NPT) OR B16.18 (SOLDER)

MATERIAL LIST

PART	SPECIFICATION
1. Body	Bronze ASTM B584 Alloy C84400 (Solder) Bronze ASTM B62 Alloy C83600 (Threaded)
2. Cap	Bronze ASTM B62 Alloy C83600
3. Gasket	PTFE
4. Screen	ASTM E2016 20 Mesh - 304 Stainless Steel or ASTM E674 Perforated - 304 Stainless Steel
5. Plug	Brass ASTM B16 Alloy C36000 or Bronze ASTM B584 Alloy C84400

END CONNECTION	SCREEN	CAP
S- Solder	221 - 20 Mesh (STD.)	A - Tapped Cap w/Plug (STD.)
T - Threaded	222 - Perforated*	B - Solid Cap

*331 1/32" perforations per square inch.

DIMENSIONS—WEIGHTS—QUANTITIES

Size	Dimensions								T-221		S-221		Master Ctn. Qty	
	A		B		C		D		Lbs.	Kg.	Lbs.	Kg.		
In.	mm.	In.	mm.	In.	mm.	In.	mm.	In.	mm.					
1/4	8	1.75	45	2.53	64	1.79	46	1/4	8	0.74	0.33	—	—	50
3/8	10	1.75	45	2.53	64	1.79	46	1/4	8	0.72	0.32	—	—	50
1/2	15	1.75	45	2.53	64	1.79	46	1/4	8	0.81	0.37	0.57	0.26	50
3/4	20	2.20	56	3.25	83	2.15	55	3/8	10	1.13	0.51	1.01	0.46	30
1	25	2.59	66	3.77	96	2.82	72	3/8	10	1.85	0.84	1.58	0.72	25
1 1/4	32	3.27	83	4.56	116	3.25	83	3/4	20	2.96	1.34	2.69	1.22	10
1 1/2	40	3.59	114	5.24	133	3.63	92	3/4	20	4.47	2.03	3.99	1.81	10
2	50	4.44	113	5.95	151	5.00	127	1	25	7.43	3.37	6.94	3.15	6
2 1/2	65	—	—	7.98	203	5.70	145	1 1/4	32	14.94	6.78	—	—	3
3	80	—	—	9.28	236	6.52	166	1 1/2	40	21.68	9.84	—	—	2

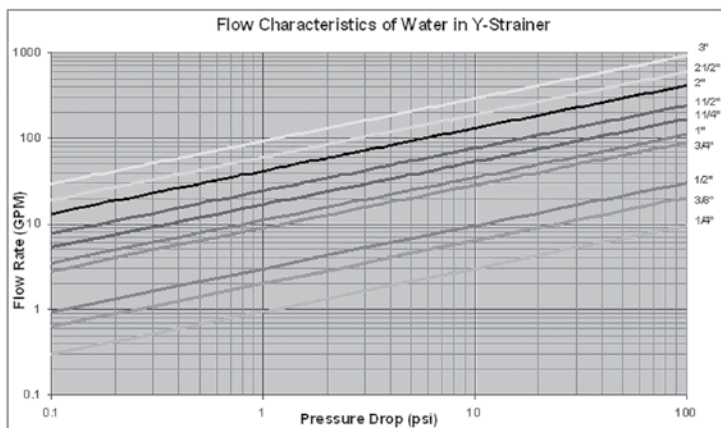

T-221/222-A
Threaded

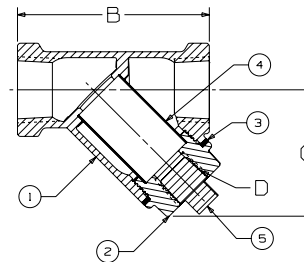

T-221/222-A
Threaded

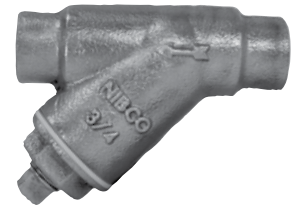

S-221/222-A
Solder

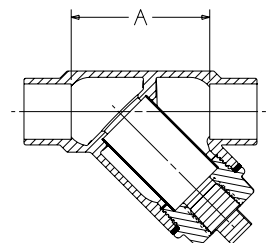

S-221/222-A
Solder



T-221/222-B
Threaded

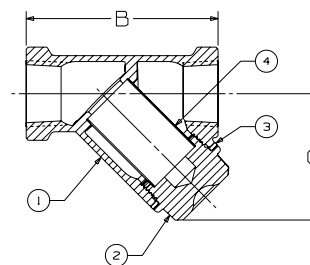

T-221/222-B
Threaded





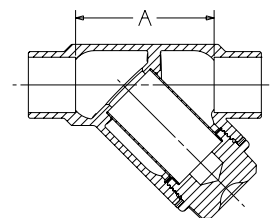



S-221/222-B
Solder



S-221/222-B
Solder

Visit our website for the most current information.

Iron Gate Valves Illustrated Index

<p>Iron Body Gate Valve Outside Screw and Yoke 125 lb. SWP 200 lb. CWP</p>  <p>F-617-O/F-617-ON T-617-O/T-617-ON Rising Stem • Solid Wedge Sizes 2" thru 24" Flanged Sizes 2" thru 4" only Threaded Page 39-42</p>	<p>Iron Body Gate Valve Inside Screw 125 lb. SWP 200 lb. CWP</p>  <p>F-619/F-619-N T-619/T-619-N Non-Rising Stem • Solid Wedge Sizes 2" thru 16" Flanged Sizes 2" thru 4" only Threaded Page 43, 44</p>	<p>Iron Body Gate Valve Outside Screw and Yoke Resilient Wedge 300 lb. CWP</p>  <p>F-607-RWS Rising Stem • Resilient Wedge Sizes 2½" thru 12" Flanged Page 45</p>
<p>Iron Body Gate Valve Inside Screw 250 lb. CWP</p>  <p>F-619-RWS/MJ-619-RWS P-619-RW/PCR-619-RW/FPCR-619-RW Non-Rising Stem • Resilient Wedge Sizes 2" thru 12" Flanged Sizes 3" thru 12" Mechanical Joint Sizes 2" thru 12" IPS Push On Sizes 4" thru 12" C509 Push On Sizes 4" thru 12" C509 Push On by Flanged Page 46-50</p>	<p>Iron Body Gate Valve Outside Screw and Yoke 250 lb. SWP 500 lb. CWP</p>  <p>F-667-O Rising Stem • Solid Wedge Sizes 2" thru 12" Flanged Page 51</p>	<p>Iron Body Gate Valve Inside Screw 250 lb. SWP 500 lb. CWP</p>  <p>F-669 Non-Rising Stem • Solid Wedge Sizes 2" thru 12" Flanged Page 52</p>

Chemical Compatibility

Please consult the most current edition of the NIBCO Chem-Guide for recommendations regarding chemical compatibility of material exposure to specific media and media-treatment additives. The NIBCO Chem-Guide is a general guide on the topic of chemical compatibility and is by no means an exhaustive resource on the subject. Ultimately, proper material selection is the responsibility of the installer and/or end-user, taking into account all aspects of a system's design and intended use.

Galvanic Potential in Piping Systems

Galvanic corrosion or dissimilar metal corrosion is an electrochemical process that is created through the electrical interaction of two different metals under the influence of a conductive media (i.e. an electrolyte). An electrolytic cell, much like a battery, is generated by these dissimilar metals using water as the electrolyte. The electrical charge, developed within the electrolytic cell, drives a preferential attack on the more electrically active metal with the water acting as the recipient of the discarded metal ions. Such galvanic attack is often encountered in service where iron or steel components are installed, and later corrode, in a largely copper piping system. Please consult NIBCO Technical Bulletin NTB-0714-01 Dielectric Products Relative to Electrolysis and Galvanic Corrosion.

Visit our website for the most current information.

Class 125 Iron Body Gate Valves

Bolted bonnet • outside screw and yoke • solid wedge • bronze mounted

200 PSI/13.8 bar non-shock cold working pressure to -20°F to 150°F/-29°C to 66°C

Maximum working temperature 450°F/232°C at 125 PSI/8.6 bar

125 PSI/8.6 bar saturated steam to 353°F/178°C

CONFORMS TO MSS SP-70

MATERIAL LIST

PART	SPECIFICATION
1. Stem	Brass ASTM B16 Alloy C36000
2. Handwheel Nut	Brass ASTM B584 Alloy C84400
3. Identification Plate	Aluminum
4. Yoke Bushing	Brass ASTM B584 Alloy C84400
5. Handwheel	Cast Iron ASTM A126 Class B
6. Bonnet Cap Nut	Steel ASTM A563
7. Bonnet Cap	Ductile Iron ASTM A536
8. Bonnet ¹	Cast Iron ASTM A126 Class B
9. Bonnet Cap Bolt	Steel ASTM A307/ SAE J429
10. Gland Follower Nut	Steel ASTM B563
11. Gland Follower	Ductile Iron ASTM A536
12. Packing Gland	Zinc Plated Powdered Iron ASTM B783 or Brass ASTM B16 Alloy C36000
13. Packing	Synthetic Fibers with Graphite
14. Gland Follower Bolt	Steel ASTM A307/ SAE J429
15. Backseat Bushing	Brass ASTM B584 Alloy C84400
16. Body Nut	Steel ASTM A563
17. Body Bolt	Steel ASTM A307/ SAE J429
18. Wedge Pin	ASTM B140 Alloy C31600
19. Body	Cast Iron ASTM A126 Class B
20. Seat Ring	Brass ASTM B584 Alloy C84400
21. Wedge Face Ring	Brass ASTM B584 Alloy C84400
22. Wedge ²	Cast Iron ASTM A126 Class B
23. Body Gasket	Synthetic Fibers
24. Stem Collar	Brass ASTM B16 Alloy C36000

¹Sizes thru 8" made with Yoke Integral with Bonnet. 10" and 12" sizes made with separate Yoke Bolted to Bonnet.

²Sizes 2" thru 6" are all Bronze Wedges. Sizes 8" thru 12" made with Cast Iron Wedge with Bronze Wedge Face Rings.



F-617-0
Flanged



T-617-0
Threaded

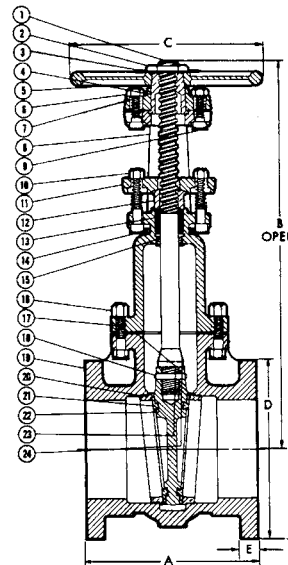

F-617-0
Flg x Flg

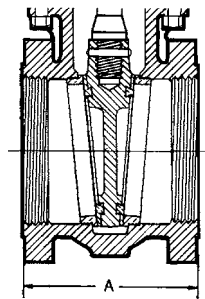

T-617-0
NPT x NPT

DIMENSIONS—WEIGHTS—QUANTITIES

Size	Dimensions																
	F-617-0		T-617-0		B	C	D	E	F-617-0		T-617-0						
	A	A	A	A					Lbs.	Kg.	Lbs.	Kg.					
2	50	7.00	178	5.63	143	16.31	414	8	203	6.00	152	.63	16	41	19	30	14
2½	65	7.50	191	5.88	149	17.19	437	8	203	7.00	178	.69	17	55	25	39	18
3	80	8.00	203	6.13	156	19.50	495	8	203	7.50	191	.75	19	67	30	47	21
4	100	9.00	229	6.50	165	24.00	610	10	254	9.00	229	.94	24	107	48	77	35
5	125	10.00	254	x	x	27.13	689	10	254	10.00	254	.94	24	145	66	x	x
6	150	10.50	267	x	x	31.06	789	12	305	11.00	279	1.00	25	178	81	x	x
8	200	11.50	292	x	x	40.19	1021	14	356	13.50	343	1.13	29	309	140	x	x
10	250	13.00	330	x	x	48.25	1226	16	406	16.00	406	1.19	30	481	218	x	x
12	300	14.00	356	x	x	56.88	1445	18	457	19.00	483	1.25	32	706	320	x	x

x = Not available this size.

FREEZING WEATHER PRECAUTION: Subsequent to testing a piping system, valves should be left in an open position to allow complete drainage.

VISIT WWW.NIBCO.COM FOR CURRENT CHEM-GUIDE AND GALVANIC POTENTIAL IN PIPING SYSTEMS INFORMATION.

Visit our website for the most current information.

◆For detailed Operating Pressure, refer to Pressure Temperature Chart on page 114.

Class 125 Iron Body Gate Valves

Bolted bonnet • outside screw and yoke • solid wedge • bronze mounted

150 PSI/10.3 bar non-shock cold working pressure from -20°F to 150°F/-29°C to 66°C*

Maximum working temperature 350°F/177°C at 100 PSI/6.9 bar

***100 PSI/6.9 bar saturated steam to 338°F/170°C**

****50 PSI/3.4 bar saturated steam to 297°F/147°C**

CONFORMS TO MSS SP-70

MATERIAL LIST

PART	SPECIFICATION
1. Handwheel Nut	Brass ASTM B584 Alloy C84400
2. I.D. Tag	Aluminum
3. Handwheel	Fabricated Steel
4. Yoke Bushing	Brass ASTM B584 Alloy C84400
5. Split Yoke Bolt	Steel ASTM A307/SAE J429
6. Split Yoke Bolt Nut	Steel ASTM A563
7. Yoke	Cast Iron ASTM A126 Class B
8. Gland Follower Nut	Brass ASTM B16 Alloy C36000
9. Gland Follower	Cast Iron ASTM A126 Class B or Ductile Iron ASTM A536
10. Yoke Bolt	Steel ASTM A307/SAE J429
11. Yoke Bolt Nut	Steel ASTM A563
12. Gland Follower Bolt	Steel ASTM A307/SAE J429
13. Packing Gland	Brass ASTM B584 Alloy C84400 or Brass ASTM B16 C36000
14. Packing	Synthetic Fibers with Graphite
15. Backseat Bushing	Brass ASTM B584 Alloy C84400
16. Bonnet	Cast Iron ASTM A126 Class B
17. Stem	Brass ASTM B16 Alloy C36000
18. Bonnet Bolt	Steel ASTM A307/SAE J429
19. Bonnet Bolt Nut	Steel ASTM A563
20. Bonnet Gasket	Synthetic Fibers
21. Body	Cast Iron ASTM A126 Class B
22. Wedge	Cast Iron ASTM A126 Class B
23. Seat Ring	Brass ASTM B584 Alloy C84400
24. Wedge Ring	Brass ASTM B584 Alloy C84400
25. Swing Nut	Steel ASTM A563
26. Swing Bolt	Steel ASTM A307/SAE J429
27. Grease Fitting	Alemite 1743B (not shown)
28. Stem Collar	Brass ASTM B16 Alloy C36000 (not shown)
29. Wedge Pin	Brass ASTM B 371 C69400 (not shown)
30. Wedge Nut	Bronze ASTM B 61 C92200 (not shown)



F-617-0
Flanged

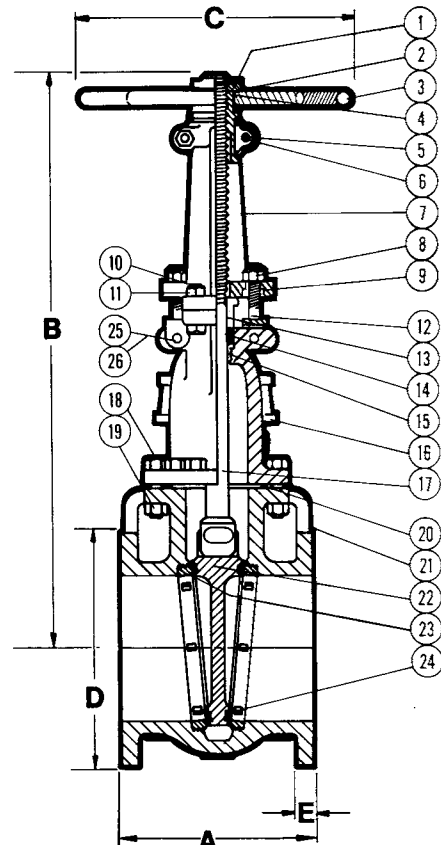

F-617-0
Fig x Fig

DIMENSIONS—WEIGHTS—QUANTITIES

Size	Dimensions										Turns to Open	Weight		
	A	B	C	D	E	A	B	C	D	E		Lbs.	Kg.	
14	350	15	381	65.50	1660	24	610	21.00	533	1.38	35	29.38	892	405
16	400	16	407	74.50	1892	24	610	23.50	597	1.44	37	33.50	1253	568
18	450	17	432	82.50	2096	24	610	25.00	635	1.56	40	37.63	1598	725
20	500	18	457	91.00	2311	30	762	27.50	699	1.69	43	41.88	2000	907
24	600	20	508	107.50	2731	30	762	32.00	813	1.88	48	50.06	2909	1319

*18", 20" and 24"

** 14" and 16"

FREEZING WEATHER PRECAUTION: Subsequent to testing a piping system, valves should be left in an open position to allow complete drainage.

◆ For detailed Operating Pressure, refer to Pressure Temperature Chart on page 114.

VISIT WWW.NIBCO.COM FOR CURRENT CHEM-GUIDE AND GALVANIC POTENTIAL IN PIPING SYSTEMS INFORMATION.

Visit our website for the most current information.

Class 125 All Iron Trim Iron Body Gate Valves

Bolted bonnet • outside screw and yoke • solid wedge

200 PSI/13.8 bar non-shock cold working pressure to -20°F to 150°F/-29°C to 66°C*

Maximum working temperature 450°F/232°C at 125 PSI/8.6 bar

125 PSI/8.6 bar saturated steam to 353°F/178°C

CONFORMS TO MSS SP-70

MATERIAL LIST

PART	SPECIFICATION
1. Stem	Steel ASTM A108 12L14 Electroless Ni-Pi
2. Handwheel Nut	Ductile Iron ASTM A536
3. Identification Plate	Aluminum
4. Yoke Bushing	Ductile Iron ASTM A536
5. Handwheel	Cast Iron ASTM A126 Class B
6. Bonnet Cap Nut	Steel ASTM A563
7. Bonnet Cap	Ductile Iron ASTM A536
8. Bonnet ¹	Cast Iron ASTM A126 Class B
9. Bonnet Cap Bolt	Steel ASTM A307/SAE J429
10. Gland Follower Nut	Steel ASTM A563
11. Gland Follower	Ductile Iron ASTM A536
12. Packing Gland	Zinc Plated Powdered Iron ASTM B783 or Brass ASTM B16 Alloy C3600
13. Packing	PTFE Braided Synthetic Fiber
14. Gland Follower Bolt	Steel ASTM A307/SAE J429
15. Backseat Bushing	Steel ASTM A108 12L14
16. Body Nut	Steel ASTM A563
17. Body Bolt	Steel ASTM A307/SAE J429
18. Wedge Pin	Steel ASTM A108 12L14
19. Body	Cast Iron ASTM A126 Class B
20. Seat Ring	Cast Iron ASTM A126 Class B
21. Wedge Face	Cast Iron ASTM A126 Class B
22. Wedge	Cast Iron ASTM A126 Class B
23. Body Gasket	Synthetic Fibers
24. Stem Collar	Steel ASTM A108 12L14
25. Grease Fitting	Alemite 1743B (not shown)

¹Sizes thru 8" made with Yoke Integral with Bonnet. 10" and 12" sizes made with separate Yoke Bolted to Bonnet.



F-617-ON
Flanged



T-617-ON
Threaded

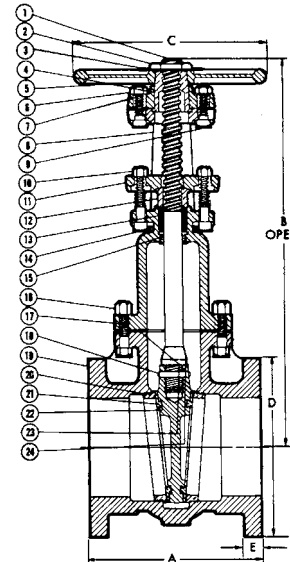

F-617-ON
Flg x Flg

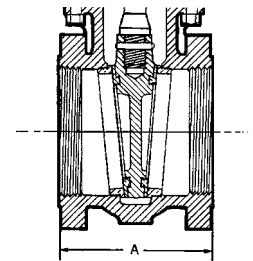

T-617-ON
NPT x NPT

DIMENSIONS—WEIGHTS—QUANTITIES

Dimensions

Size	F-617-ON		T-617-ON		B	C	D	E	F-617-ON		T-617-ON						
	In.	mm.	In.	mm.					Lbs.	Kg.	Lbs.	Kg.					
2	50	7.00	178	5.63	143	16.31	414	8	203	6.00	152	.63	16	41	18	30	14
2½	65	7.50	191	5.88	149	17.19	437	8	203	7.00	178	.69	17	55	25	39	18
3	80	8.00	203	6.13	156	19.50	495	8	203	7.50	191	.75	19	66	30	47	21
4	100	9.00	229	6.50	165	24.00	610	10	254	9.00	229	.94	24	104	47	77	35
5	125	10.00	254	x	x	27.13	689	10	254	10.00	254	.94	24	144	65	x	x
6	150	10.50	267	x	x	31.06	789	12	305	11.00	279	1.00	25	178	81	x	x
8	200	11.50	292	x	x	40.19	1021	14	356	13.50	343	1.13	29	309	140	x	x
10	250	13.00	330	x	x	48.25	1226	16	406	16.00	406	1.19	30	481	218	x	x
12	300	14.00	356	x	x	56.88	1445	18	457	19.00	483	1.25	32	702	318	x	x

x = Not available this size.

FREEZING WEATHER PRECAUTION: Subsequent to testing a piping system, valves should be left in an open position to allow complete drainage.

VISIT WWW.NIBCO.COM FOR CURRENT CHEM-GUIDE AND GALVANIC POTENTIAL IN PIPING SYSTEMS INFORMATION.

Visit our website for the most current information.

◆For detailed Operating Pressure, refer to Pressure Temperature Chart on page 114.

Class 125 All Iron Trim Iron Body Gate Valves

Bolted bonnet • outside screw and yoke • solid wedge

150 PSI/10.3 bar non-shock cold working pressure from -20°F to 150°F/-29°C to 66°C♦

Maximum working temperature 350°F/177°C at 100 PSI/6.9 bar

***100 PSI/6.9 bar saturated steam to 338°F/170°C**

****50 PSI/3.4 bar saturated steam to 297°F/147°C**

CONFORMS TO MSS SP-70

MATERIAL LIST

PART	SPECIFICATION
1. Handwheel Nut	Ductile Iron ASTM A536
2. Identification Tag	Aluminum
3. Handwheel	Fabricated Steel
4. Yoke Bushing	Ductile Iron ASTM A536
5. Split Yoke Bolt	Steel ASTM A307/SAE J429
6. Split Yoke Bolt Nut	Steel ASTM A307
7. Yoke	Cast Iron ASTM A126 Class B
8. Gland Follower Nut	Steel ASTM A563
9. Gland Follower	Ductile Iron ASTM A536
10. Yoke Bolt	Steel ASTM A307/SAE J429
11. Yoke Bolt Nut	Steel ASTM A563
12. Gland Follower Bolt	Steel ASTM A307/SAE J429
13. Packing Gland	Steel ASTM A 108 12L14
14. Packing	PTFE Braided
15. Backseat Bushing	Steel ASTM A108 12L14
16. Bonnet	Cast Iron ASTM A126 Class B
17. Stem	Steel ASTM A 108 12L14 Electroless NI-PI
18. Bonnet Bolt	Steel ASTM A307/SAE J429
19. Bonnet Bolt Nut	Steel ASTM A563
20. Bonnet Gasket	Synthetic Fibers
21. Body	Cast Iron ASTM A126 Class B
22. Wedge	Cast Iron ASTM A126 Class B
23. Seat Ring	Cast Iron ASTM A126 Class B
24. Grease Fitting	Alemite 1743B (not shown)
25. Swing Nut	Steel ASTM A563
26. Swing Bolt	Steel ASTM A307/SAE J429
27. Stem Collar	Steel ASTM A108 12L14 (not shown)
28. Wedge Pin	Steel ASTM A 108 12L14 (not shown)
29. Wedge Nut	Ductile Iron ASTM A536 (not shown)



F-617-ON
Flanged

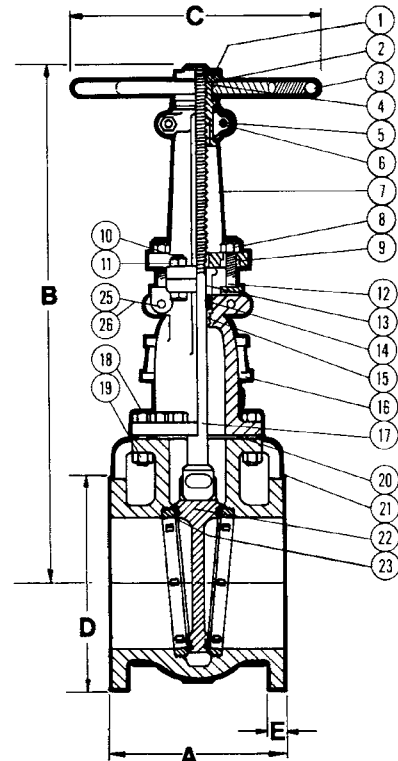

F-617-ON
Flg x Flg

DIMENSIONS—WEIGHTS—QUANTITIES

Size	Dimensions										Turns to Open	Weight		
	A		B		C		D		E			Lbs.	Kg.	
In.	mm.	In.	mm.	In.	mm.	In.	mm.	In.	mm.	In.	mm.			
14	350	15	381	65.50	1660	24	610	21.00	533	1.38	35	29.38	890	404
16	400	16	407	74.50	1892	24	610	23.50	597	1.44	37	33.50	1252	568
18*	450	17	432	82.50	2096	24	610	25.50	635	1.56	40	37.63	1595	724
20*	500	18	457	91.00	2311	30	762	27.50	699	1.69	43	41.88	2001	907
24*	600	20	508	107.50	2731	30	762	32.00	813	1.88	48	50.06	2879	1306

*18", 20" and 24"

** 14" and 16"

FREEZING WEATHER PRECAUTION: Subsequent to testing a piping system, valves should be left in an open position to allow complete drainage.

♦ For detailed Operating Pressure, refer to Pressure Temperature Chart on page 114.

VISIT WWW.NIBCO.COM FOR CURRENT CHEM-GUIDE AND GALVANIC POTENTIAL IN PIPING SYSTEMS INFORMATION.

Visit our website for the most current information.

Class 125 Iron Body Gate Valves

Bolted bonnet • non-rising stem • solid wedge • bronze mounted

200 PSI/13.8 bar non-shock cold working pressure from -20°F to 150°F/-29°C to 66°C

Maximum working temperature 450°F/232°C at 125 PSI/8.6 bar

125 PSI/8.6 bar saturated steam to 353°F/178°C

CONFORMS TO MSS SP-70

MATERIAL LIST

PART	SPECIFICATION
1. Handwheel Nut	Steel ASTM A307
2. Identification Plate	Aluminum
3. Handwheel or Square Operating Nut	Cast Iron ASTM A126 Class B
4. Stem	Brass ASTM B16 Alloy C36000
5. Gland Follower Nut	Brass ASTM F467 Alloy C27000
6. Gland Follower	Cast Iron ASTM A126 Class B or Ductile Iron ASTM A536
7. Gland Follower Bolt	Steel ASTM A307/SAE J429
8. Packing Gland	Zinc Plated Powdered Iron ASTM B783 or Brass ASTM B16
9. Stuffing Box	Cast Iron ASTM A126 Class B
10. Packing	Synthetic Fibers with Graphite
11. Stuffing Box Gasket	Synthetic Fibers
12. Bonnet	Cast Iron ASTM A126 Class B
13. Body Bolt	ASTM A307/SAE J429
14. Body Gasket	Synthetic Fibers
15. Body Nut	Steel ASTM A307/SAE J429
16. ¹ Wedge Bushing	Brass ASTM B584 Alloy C84400
17. Seat Ring	Brass ASTM B584 Alloy C84400
18. Wedge Face Ring	Brass ASTM B584 Alloy C84400
19. ¹ Wedge	Cast Iron ASTM A126 Class B
20. Body	Cast Iron ASTM A126 Class B
21. Stuffing Box Nut	Steel ASTM A307 (not shown) /SAE J429

¹Sizes thru 6" have Bronze Wedges. Sizes 8" thru 16" made with Cast Iron Wedge with Bronze Bushing and Wedge Face Rings.

NOTE: 14" thru 16" Maximum Steam Rating 100 PSI/6.9 Bar
Maximum Non-Shock Cold Working Pressure 150 PSI/10.3 Bar

DIMENSIONS—WEIGHTS—QUANTITIES

Size	Dimensions												F-619		T-619		
	A		A		B		C		D		E		Lbs.	Kg.	Lbs.	Kg.	
In.	mm.	In.	mm.	In.	mm.	In.	mm.	In.	mm.	In.	mm.	In.	mm.	Lbs.	Kg.	Lbs.	Kg.
2	50	7.00	178	5.63	143	11.00	279	7	178	6.00	152	.63	16	35	16	25	11
2½	65	7.50	191	5.88	149	12.50	318	7	178	7.00	178	.69	17	49	22	33	15
3	80	8.00	203	6.13	156	13.50	343	8	203	7.50	191	.75	19	60	27	42	19
4	100	9.00	229	6.50	165	15.75	400	10	254	9.00	229	.94	24	90	41	61	28
5	125	10.00	254	x	x	17.00	432	10	254	10.00	254	.94	24	129	59	x	x
6	150	10.50	267	x	x	21.00	533	12	305	11.00	279	1.00	25	161	73	x	x
8	200	11.50	292	x	x	25.00	635	14	356	13.50	343	1.13	29	277	126	x	x
10	250	13.00	330	x	x	29.00	737	16	406	16.00	406	1.19	30	415	188	x	x
12	300	14.00	356	x	x	34.50	876	18	457	19.00	483	1.25	32	631	287	x	x
14	350	15.00	381	x	x	40.38	1026	24	610	21.00	533	1.38	35	869	394	x	x
16	400	16.00	407	x	x	45.75	1162	24	610	23.50	597	1.44	37	1224	555	x	x

x = Not available this size.

VISIT WWW.NIBCO.COM FOR CURRENT CHEM-GUIDE AND GALVANIC POTENTIAL IN PIPING SYSTEMS INFORMATION.

Visit our website for the most current information.



T-619
Threaded



F-619-SON
Flanged
With Square Op. Nut



F-619
Flanged

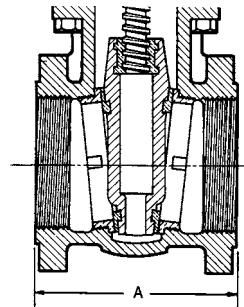

T-619
NPT x NPT

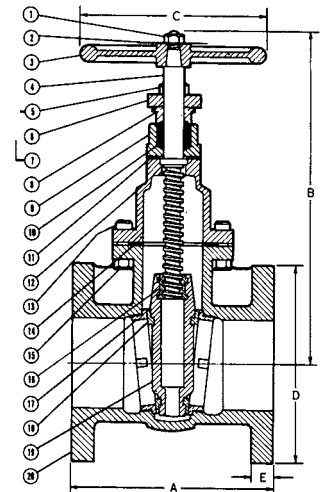

F-619
Flg x Flg

Position indicators available. See page 98.

FREEZING WEATHER PRECAUTION: Subsequent to testing a piping system, valves should be left in an open position to allow complete drainage.

◆For detailed Operating Pressure, refer to Pressure Temperature Chart on page 114.

Class 125 All Iron Trim Iron Body Gate Valves

Bolted bonnet • non-rising stem • solid wedge

200 PSI/13.8 bar non-shock cold working pressure to -20° F to 150° F/-29° C to 66° C*

Maximum working temperature 450°F/232°C at 125 PSI/8.6 bar

125 PSI/8.6 bar saturated steam to 353° F/178° C

CONFORMS TO MSS SP-70

MATERIAL LIST

PART	SPECIFICATION
1. Handwheel Nut	Steel ASTM A563
2. Identification Plate	Aluminum
3. Handwheel	Cast Iron ASTM A126 Class B
4. Stem	Steel ASTM A 108 12L14 Electroless NI-PI
5. Gland Follower Nut	Steel ASTM A563
6. Gland Follower	Ductile Iron ASTM A536
7. Gland Follower Bolt	Steel ASTM A307/SAE J429
8. Packing Gland	Zinc Plated Powdered Iron ASTM B783
9. Stuffing Box	Cast Iron ASTM A126 Class B
10. Packing	PTFE Braided
11. Stuffing Box Gasket	Synthetic Fibers
12. Bonnet	Cast Iron ASTM A126 Class B
13. Body Bolt	Steel ASTM A307/SAE J429
14. Body Gasket	Synthetic Fibers
15. Body Nut	Steel ASTM A563
16. Seat Ring	Cast Iron ASTM A126 Class B
17. Wedge	Cast Iron ASTM A126 Class B
18. Body	Cast Iron ASTM A126 Class B
19. Stuffing Box Nut	Steel ASTM A563 (not shown)

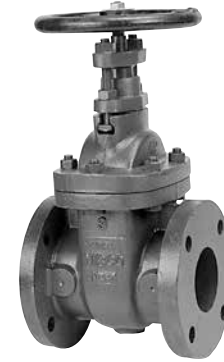

F-619-N
Flanged

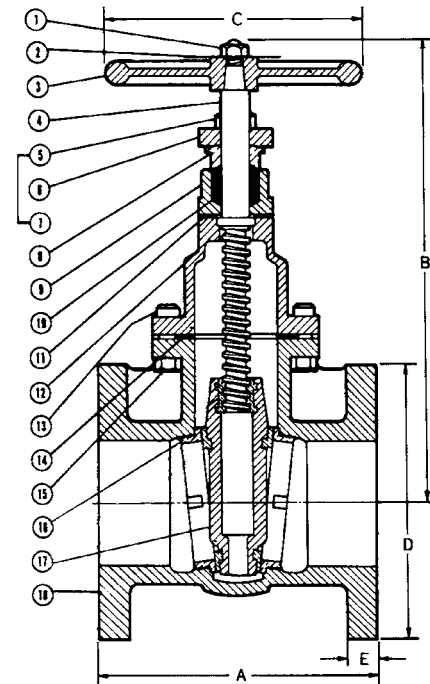

F-619-N
Flg x Flg

DIMENSIONS—WEIGHTS—QUANTITIES

Size	Dimensions										Weight		
	A		B		C		D		E		Lbs.	Kg.	
In. mm.	In.	mm.	In.	mm.	In.	mm.	In.	mm.	In.	mm.			
2	50	7.00	178	11.00	279	7	178	6.00	152	.63	16	35	16
2½	65	7.50	191	12.50	318	7	178	7.00	178	.94	17	49	22
3	80	8.00	203	13.50	343	8	203	7.50	191	.75	19	60	27
4	100	9.00	229	15.75	400	10	254	9.00	229	.94	24	90	41
5	125	10.00	254	17.00	432	10	254	10.00	254	.94	24	129	59
6	150	10.50	267	21.00	533	12	305	11.00	279	1.00	25	161	73
8	200	11.50	292	25.00	635	14	356	13.50	343	1.13	29	277	126
10	250	13.00	330	29.00	737	16	406	16.00	406	1.19	30	415	188
12	300	14.00	356	34.50	876	18	457	19.00	483	1.25	32	631	287
14*	350	15.00	381	40.38	1026	20	508	21.00	533	1.38	35	869	394
16*	400	16.00	407	45.75	1162	22	559	23.50	597	1.44	37	1224	555

* 14"-16" sizes rated to 100 PSI maximum steam service, 150 PSI Non-Shock Cold Working Pressure.
For higher pressures, see F-639.

x Not available this size.

Position indicators available. See page 98

FREEZING WEATHER PRECAUTION: Subsequent to testing a piping system, valves should be left in an open position to allow complete drainage.

◆ For detailed Operating Pressure, refer to Pressure Temperature Chart on page 114.

VISIT WWW.NIBCO.COM FOR CURRENT CHEM-GUIDE AND GALVANIC POTENTIAL IN PIPING SYSTEMS INFORMATION.

Visit our website for the most current information.



300 PSI CWP Iron Body Gate Valves

Fire protection valve • outside screw and yoke • resilient wedge • epoxy coated interior/exterior • pre-grooved stem for supervisory switch • drilled, tapped and plugged at boss location A**

300 PSI/20.6 bar non-shock cold working pressure

UL/ULC LISTED† • FM APPROVED • CERTIFIED LEAD-FREE* BY TRUESDAIL LABORATORIES TO NSF/ANSI 61 & 372



F-607-RWS
Flanged

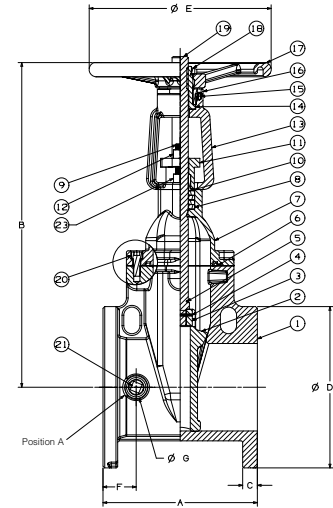

F-607-RWS
Flg x Flg

MATERIAL LIST	
PART	SPECIFICATION
1 Valve Body	Ductile Iron ASTM A536
2 Resilient Wedge	Ductile Iron ASTM A536/EPDM ASTM D2000
3 Wedge Nut	ASTM B584 UNS C83600
4 Dowel Pin	ASTM A276 SS304
5 Stem Back Seat O-Ring	EPDM ASTM D2000
6 Bonnet Gasket	EPDM ASTM D2000
7 Bonnet	Ductile Iron ASTM A536
8 Stem Packing	EPDM ASTM D2000
9 Threaded Rod	ASTM A276 SS304
10 Gland Bushing	ASTM B584 UNS C83600
11 Gland	Ductile Iron ASTM A536
12 Gland Nut	ASTM B148 C95200 Aluminum Bronze
13 Yoke	Ductile Iron ASTM A536
14 Yoke Bushing	ASTM B150 C61400
15 Flat Point Set Screw	ASTM F912M
16 Yoke Bushing Retainer	Cast Iron ASTM A126 Class B
17 Handwheel	Ductile Iron ASTM A536
18 Handwheel Nut	Carbon Steel Zinc Plated
19 Stem	Stainless Steel 304
20 Bonnet Screw	Corrosion-resistant Steel
21 NPT Pipe Plug	Steel ASME B16.14
22 UL/FM Label (not shown)	Aluminium
23 Yoke Nut	ASTM B148 C95200 Aluminum Bronze
24 Drive Screw Label (not shown)	Stainless Steel 304

Coating — Electrostatically applied fusion-bonded epoxy 8-20 mil. inside and outside. Meets or exceeds AWWA C550. Epoxy coating is not intended to serve as a dielectric barrier internal to the piping system

**Drilled, tapped and plugged at Position A with 1/2" valve sizes 2 1/2"-4", 3/4" on 6"-8", 1" on 10"-12".

† Compliance with the Standard for Gate Valves for Fire Protection Service, UL 262, and the Canadian Requirements, ULC/ORD-C262.

NOTE: Flanged valve is consistent with ANSI B16.1 Class 125.

DIMENSIONS—WEIGHTS—QUANTITIES

Size	Dimensions																Bolt Circle	Flange Holes	Turns To Open	Weight			
	A	B Open	B Closed	C	D	E	F	G	In.	mm.	In.	mm.	In.	mm.	In.	mm.				Lbs.	Kg.		
2 1/2"	65	7.5	190	17.8	453	14.9	378	0.69	17.5	7.0	178	7.9	200	1.50	38	1.42	36	5.50	140	4	6.3	39	18
3"	80	8.0	203	19.7	500	15.9	405	0.75	19.0	7.5	191	7.9	200	1.73	44	1.42	36	6.00	152	4	10.0	44	20
4"	100	9.0	229	21.0	534	16.6	422	0.94	24.0	9.0	229	10.2	260	2.13	54	1.42	36	7.50	191	8	10.0	72	33
6"	150	10.5	267	29.3	744	22.9	581	1.00	25.4	11.0	279	12.4	315	2.24	57	1.54	39	9.50	241	8	15.0	117	53
8"	200	11.5	292	37.0	939	28.5	724	1.13	28.6	13.5	343	14.8	375	2.48	63	1.54	39	11.75	298	8	16.7	198	90
10"	250	13.0	330	44.8	1139	34.5	877	1.19	30.2	16.0	406	16.4	416	3.15	80	1.82	46	14.25	362	12	20.8	374	170
12"	300	14.0	356	52.2	1326	39.9	1014	1.25	31.8	19.0	483	17.5	445	2.91	74	1.82	46	17.00	432	12	25.0	493	224
14*	350	15.0	375	62.2	1580	50.0	1270	1.38	35.0	21.0	533	19.7	500	2.95	75	3.20	81	18.75	476	12	43.8	620	284
16*	400	16.0	400	65.9	1674	50.4	1280	1.44	37.0	23.5	597	19.7	500	3.03	77	3.20	81	21.25	540	16	50.0	816	370

*14 and 16" valves 250 PSI CWP

*Weighted average lead content ≤ 0.25%

VISIT WWW.NIBCO.COM FOR CURRENT CHEM-GUIDE AND GALVANIC POTENTIAL IN PIPING SYSTEMS INFORMATION.

Visit our website for the most current information.

FREEZING WEATHER PRECAUTION: Subsequent to testing a piping system, valves should be left in an open position to allow complete drainage.

300 PSI CWP Iron Body Gate Valves

Bolted Bonnet • Non-Rising Stem • Resilient Wedge • Flanged Ends

300 PSI/20.6 bar non-shock cold working pressure

MEETS/EXCEEDS PERFORMANCE REQUIREMENTS OF AWWA C509 & C515
CERTIFIED LEAD-FREE* BY TRUESDAIL LABORATORIES
TO NSF/ANSI 61 AND 372



NSF/ANSI 61
NSF/ANSI 372



F-619-RWS
Flanged



F-619-RWS-SON
Flanged

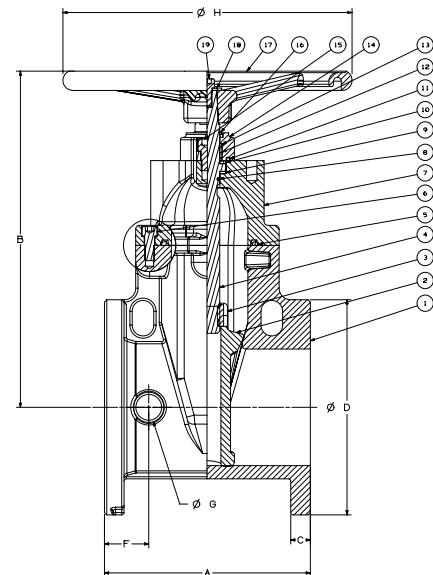

F-619-RWS

Flg x Flg

Shown with optional handwheel,
square operating nut not shown

MATERIAL LIST

PART	SPECIFICATION
1 Valve Body	Ductile Iron ASTM A536
2 Resilient Wedge	Ductile Iron ASTM A536 / EPDM ASTM D2000
3 Wedge Nut	ASTM B584 UNS C83600
4 Stem	Stainless Steel 304
5 Bonnet Gasket	EPDM ASTM D2000
6 Bonnet Screw	Corrosion-resistant Steel
7 Bonnet	Ductile Iron ASTM A536
8 Stem Primary O-Ring	EPDM ASTM D2000
9 Stem Thrust Washer (lower)	Bronze ASTM B584 UNS C83600
10 Stem Thrust Washer (upper)	Stainless Steel ASTM A276 UNS S41000
11 Gland Seal O-Ring	EPDM ASTM D2000
12 Stem Seal Bushing	ASTM B584 UNS C83600
13 Stem Secondary O-Ring	EPDM ASTM D2000
14 Gland Flange	Ductile Iron ASTM A536
15 Stem Ring Wiper	EPDM ASTM D2000

Coating — Electrostatically applied fusion-bonded epoxy 8-20 mil. inside and outside.
Meets or exceeds performance requirements of AWWA C550.
Epoxy coating is not intended to serve as a dielectric barrier internal to the piping system.

NOTE: Flanged valve is consistent with ANSI B16.1 Class 125.

NOTE: 14" & 16" sizes rated to 250 psi

DIMENSIONS—WEIGHTS—QUANTITIES

Size	Dimensions														Bolt Circle	Flange Holes	Turns to Open	Weight			
	A	B	C	D	F	G	H	In.	mm.	In.	mm.	Lbs.	Kg.								
2	50	7.0	178	10.0	255	0.63	16.0	6.0	152	1.42	36	1.6	40	7.9	200	4.75	121	4	6.3	22	10
2½	65	7.5	190	11.3	287	0.69	17.5	7.0	178	1.50	38	1.6	40	7.9	200	5.50	140	4	8.1	29	13
3	80	8.0	203	12.6	321	0.75	19.0	7.5	191	1.73	44	1.42	36	10.2	260	6.00	152	4	10.0	35	16
4	100	9.0	229	13.5	344	0.94	24.0	9.0	229	2.13	54	1.42	36	10.2	260	7.50	191	8	12.5	75	34
6	150	10.5	267	17.4	441	1.00	25.4	11.0	279	2.24	57	1.54	39	14.8	375	9.50	241	8	15.0	105	48
8	200	11.5	292	20.8	529	1.13	28.6	13.5	343	2.48	63	1.54	39	14.8	375	11.75	298	8	16.7	163	74
10	250	13.0	330	24.2	614	1.19	30.2	16.0	406	2.56	65	1.82	46	15.7	400	14.25	362	12	20.8	256	116
12	300	14.0	356	27.6	700	1.25	31.8	19.0	483	2.91	74	1.82	46	19.7	500	17.00	432	12	25.0	399	181
14	350	15.0	381	31.8	807	1.38	35.0	21.0	533	2.95	75	3.1	80	19.7	500	18.75	476	12	43.8	620	281
16	400	16.0	406	34.1	869	1.46	37.0	23.5	597	3.00	77	3.1	80	19.7	500	21.25	540	16	50.0	816	370

*Weighted average lead content ≤ 0.25%

VISIT WWW.NIBCO.COM FOR CURRENT CHEM-GUIDE AND GALVANIC POTENTIAL IN PIPING SYSTEMS INFORMATION.

Visit our website for the most current information.

FREEZING WEATHER PRECAUTION: Subsequent to testing a piping system, valves should be left in an open position to allow complete drainage.

300 PSI CWP Iron Body Gate Valves

Bolted bonnet • non-rising stem • resilient wedge • mechanical joint ends

300 PSI/20.6 bar non-shock cold working pressure

MEETS/EXCEEDS PERFORMANCE REQUIREMENTS OF AWWA C509 & C515
CERTIFIED LEAD-FREE* BY TRUESDAIL LABORATORIES
TO NSF/ANSI 61 & 372



MATERIAL LIST

PART	SPECIFICATION
1 Valve Body	Ductile Iron ASTM A536
2 Resilient Wedge	Ductile Iron ASTM A536 / EPDM ASTM D2000
3 Wedge Nut	ASTM B584 UNS C83600
4 Stem	Stainless Steel 304
5 Bonnet Gasket	EPDM ASTM D2000
6 Bonnet Screw	Corrosion-resistant Steel
7 Bonnet	Ductile Iron ASTM A536
8 Stem Primary O-Ring	EPDM ASTM D2000
9 Stem Thrust Washer (lower)	Bronze ASTM B584 UNS C83600
10 Stem Thrust Washer (upper)	Stainless Steel ASTM A276 UNS S41000
11 Gland Seal O-Ring	EPDM ASTM D2000
12 Stem Seal Bushing	ASTM B584 UNS C83600
13 Stem Secondary O-Ring	EPDM ASTM D2000
14 Gland Flange	Ductile Iron ASTM A536
15 Stem Ring Wiper	EPDM ASTM D2000

Coating — Electrostatically applied fusion-bonded epoxy 8-20 mil. inside and outside.
Meets or exceeds performance requirements of AWWA C550.
Epoxy coating is not intended to serve as a dielectric barrier internal to the piping system.

NOTE: Flanged valve is consistent with ANSI B16.1 Class 125.

NOTE: 14" & 16" sizes rated to 250 psi

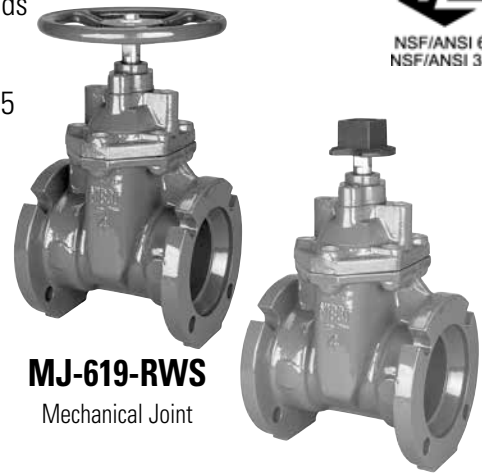

MJ-619-RWS

Mechanical Joint

MJ-619-RWS-SON

Mechanical Joint

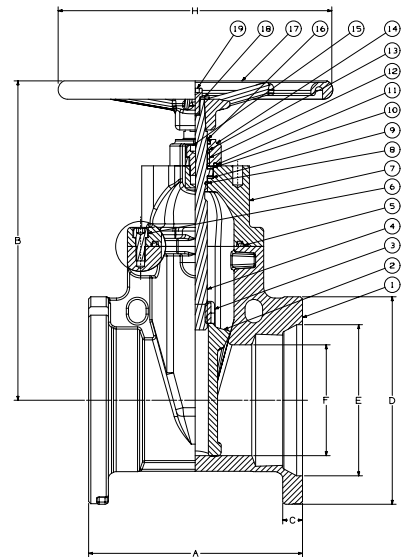

MJ-619-RWS

MJ x MJ

square operating nut not shown

DIMENSIONS—WEIGHTS—QUANTITIES

Size	Dimensions												Bolt Circle	Flange Holes	Turns to Open	Weight					
	A	B	C	D	E	F	H	In.	mm.	Lbs.	Kg.										
3	80	8.0	203	12.7	322	0.94	24	7.7	196	4.9	126	3.1	80	10.2	260	6.19	157	4	10.0	39	16
4	100	10.0	254	13.5	344	1.00	26	9.1	232	6.0	153	3.9	100	10.2	260	7.50	191	4	12.5	64	33
6	150	11.5	292	17.4	441	1.06	27	11.1	283	8.1	206	5.9	150	14.8	375	9.50	241	6	15.0	104	46
8	200	11.5	292	20.8	529	1.12	28	13.4	340	10.3	261	7.9	200	14.8	375	11.75	298	6	16.7	161	67
10	250	13.0	330	24.2	614	1.18	30	15.7	400	12.3	313	9.8	250	15.7	400	14.00	356	8	20.8	262	107
12	300	14.0	356	27.6	700	1.25	32	18.0	456	14.4	367	11.8	300	19.7	500	16.25	413	8	25.0	406	160
14	350	15.0	381	31.8	807	1.34	34	20.5	516	16.5	420	13.8	350	19.7	500	18.75	476	10	43.8	573	259
16	400	16.0	406	34.2	869	1.38	35	22.5	573	18.6	474	15.7	400	19.7	500	21.00	533	12	50.0	765	348

*Weighted average lead content ≤ 0.25%

VISIT WWW.NIBCO.COM FOR CURRENT CHEM-GUIDE AND GALVANIC POTENTIAL IN PIPING SYSTEMS INFORMATION.

Visit our website for the most current information.

FREEZING WEATHER PRECAUTION: Subsequent to testing a piping system, valves should be left in an open position to allow complete drainage.

250 PSI CWP Iron Body Gate Valves

Bolted bonnet • non-rising stem • resilient wedge • IPS PVC push-on

250 PSI/17.2 bar non-shock cold working pressure

CERTIFIED LEAD-FREE* BY IAPMO R&T TO NSF/ANSI 372
END CONNECTION DESIGNED FOR USE WITH PVC ASTM D1785,
PVC AND/OR ASME B36.10 STEEL



P-619-RW
IPS Push-On

MATERIAL LIST

PART	SPECIFICATION
1. Valve Body	Cast Iron ASTM A126-B
2. Resilient Wedge	Ductile Iron ASTM A536/EPDM ASTM D 2000
3. Wedge Nut	Bronze ASTM B584 UNS C83600 4" - 12" ASTM B584 UNS C92200 2" - 3"
4. Stem	Stainless Steel ASTM A 276 UNS S41000
5. Bonnet Gasket	EPDM ASTM D 2000
6. Bonnet Screw	18-8 Stainless Steel ASTM A193
7. Bonnet	Cast Iron ASTM A126-B
8. Stem Primary O-Ring	EPDM ASTM D 2000
9. Stem Thrust Washer (lower)	Nylon 1010
10. Stem Collar	Brass ASTM B 16 UNS C36000
11. Stem Thrust Washer (upper)	Stainless Steel ASTM A 276 UNS S41000
12. Gland Seal O-Ring	EPDM ASTM D 2000
13. Stem Seal Bushing	Nylon 1010
14. Stem Secondary O-Ring (2)	EPDM ASTM D 2000
15. Gland Flange	Ductile Iron ASTM A536
16. Stem Ring Wiper	EPDM ASTM D 2000
17. Square Operating Nut	Cast Iron ASTM A126-B
17A. Handwheel (Optional)	Ductile Iron ASTM A536
18. Operating Nut Washer	Carbon Steel Zinc Plated
19. Operating Nut Screw	Alloy Steel ASTM A 574M Zinc Plated
20. Gland Flange Screw	Alloy Steel ASTM A 574M Zinc Plated

Coating — Electrostatically applied fusion-bonded epoxy 8-20 mil. inside and outside.
Meets or exceeds performance requirements of AWWA C550.
Epoxy coating is not intended to serve as a dielectric barrier internal to the piping system.

Maximum operating temperature 160°F/71°C.

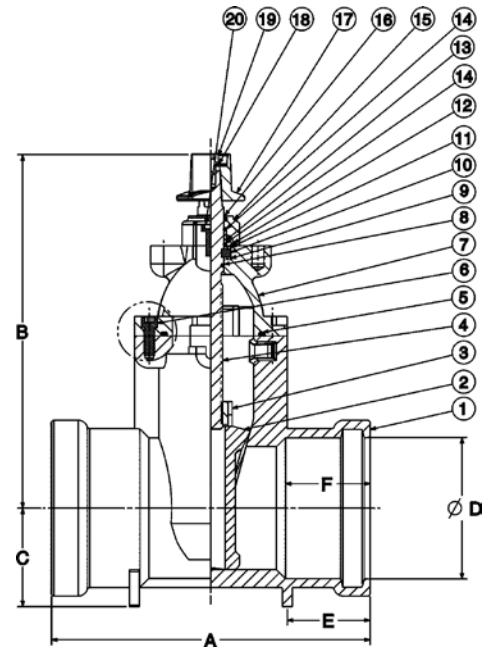

P-619-RW
IPS Push-On

DIMENSIONS—WEIGHTS—QUANTITIES

Size	Dimensions												Handwheel (Opt.) Turns to Open	Weight				
	A	B	C	D	E	F	In.	mm.	In.	mm.	Lbs.	Kg.						
2	50	11.4	289	10.2	259	2.4	60	2.48	63	2.3	58	2.7	69	7.9	200	6.5	24	11
2½	65	11.4	289	11.3	288	2.6	67	2.99	76	2.3	58	2.7	69	7.9	200	8.8	32	15
3	80	11.3	287	12.7	322	3.1	80	3.62	92	2.2	56	3.0	75	10.2	250	10.6	40	18
4	100	11.7	298	13.4	341	3.5	90	4.65	118	2.5	63	3.5	89	10.2	260	12.8	56	25
6	150	15.3	388	17.0	431	4.7	120	6.77	172	4.0	101	4.1	103	14.8	375	15.6	106	48
8	200	16.5	418	20.4	518	5.9	150	8.74	222	3.0	77	4.5	115	14.8	375	17.3	172	78
10	250	21.2	539	23.8	604	7.1	180	10.94	278	3.7	93	5.2	132	15.7	400	21.3	307	140
12	300	26.5	672	27.0	685	8.1	206	12.89	327.5	4.1	103	5.5	139	19.7	500	25.3	447	203

*Weighted average lead content ≤ 0.25%

VISIT WWW.NIBCO.COM FOR CURRENT CHEM-GUIDE AND GALVANIC POTENTIAL IN PIPING SYSTEMS INFORMATION.

Visit our website for the most current information.

FREEZING WEATHER PRECAUTION: Subsequent to testing a piping system, valves should be left in an open position to allow complete drainage.

250 PSI CWP Iron Body Gate Valve

Bolted bonnet • non-rising stem • resilient wedge

250 PSI/17.2 bar non-shock cold working pressure

CONFORMS TO AWWA C509

EPOXY MEETS OR EXCEEDS AWWA C550

END CONNECTIONS DESIGNED FOR USE WITH C900 PVC PIPE
CERTIFIED LEAD-FREE* BY IAPMO R&T TO NSF/ANSI 372



PCR-619-RW
Ductile IPS Push-On

MATERIAL LIST

PART	SPECIFICATION
1. Valve Body	Ductile Iron ASTM A536
2. Resilient Wedge	Ductile Iron Disc Encapsulated by EPDM ASTM D 2000
3. Wedge Nut	Bronze ASTM B584 Alloy C83600
4. Stem	Aluminum Bronze ASTM B 150 Alloy C61400
5. Bonnet Gasket	EPDM ASTM D 2000
6. Bonnet Screw	18-8 Stainless Steel ASTM A193
7. Bonnet	Ductile Iron ASTM A536
8. Stem Primary O-Ring	EPDM ASTM D 2000
9. Stem Thrust Washer (lower)	Bronze ASTM B584
10. Stem Thrust Washer (upper)	Stainless Steel ASTM A 276 UNS S 41000
11. Gland Seal O-Ring	EPDM ASTM D 2000
12. Stem Seal Bushing	Bronze ASTM B584
13. Stem Secondary O-Ring (2)	EPDM ASTM D 2000
14. Gland Flange	Ductile Iron ASTM A536
15. Wiper Ring - Stem	EPDM ASTM D 2000
16. Nut, Wrench - Square	Iron ASTM A126-B
17. Washer, Wrench Nut	Carbon Steel, DIN 9021 B
18. Screw WR Nut	Alloy Steel ASTM A 574 M Zinc Plated
19. Screw, Gland Flange	Alloy Steel ASTM A 574 M Zinc Plated
20. Handwheel (Optional)	Ductile ASTM A536 (not pictured)

Coating — Electrostatically applied fusion-bonded epoxy 8-20 mil. inside and outside.
Meets or exceeds performance requirements of AWWA C550.
Epoxy coating is not intended to serve as a dielectric barrier internal to the piping system.

Maximum operating temperature 160°F/71°C.

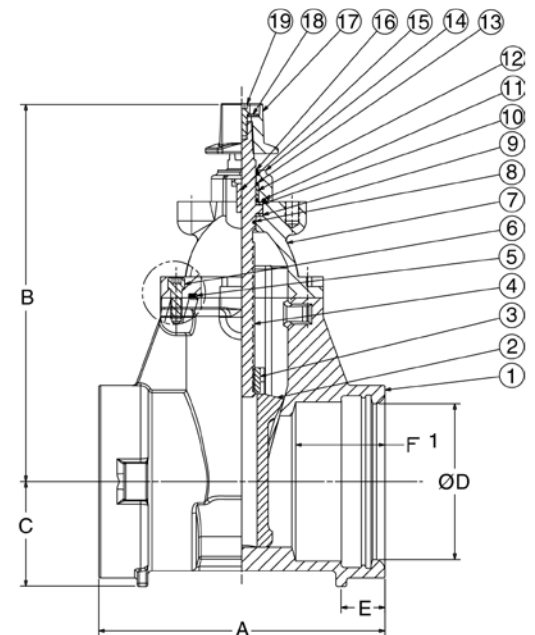

DIMENSIONS — WEIGHTS — QUANTITIES

Size	A		B		C		D		E		F		Hand Wheel (Optional)		Turns to Open	Weight		
	In.	mm.	In.	mm.	In.	mm.	In.	mm.	In.	mm.	In.	mm.	In.	mm.		Lbs.	Kg.	
4	100	10.7	272	13.5	342	3.5	90	4.9	125	1.8	46	3.5	89	10.2	260	13.0	62	28
6	150	12.9	327	17.0	432	4.7	120	7.0	178	2.0	50	4.0	102	14.8	375	15.6	106	48
8	200	15.6	396	20.4	519	5.9	150	9.2	233	2.5	64	4.5	114	14.8	375	17.3	187	85
10	250	17.0	432	23.8	605	8.0	203	11.2	285	2.4	60	5.2	132	15.7	400	21.4	286	130
12	300	18.0	457	27.0	686	9.5	242	13.3	338	2.5	64	5.5	140	19.7	500	25.3	418	190

*Weighted average lead content ≤ 0.25%

VISIT WWW.NIBCO.COM FOR CURRENT CHEM-GUIDE AND GALVANIC POTENTIAL IN PIPING SYSTEMS INFORMATION.

Visit our website for the most current information.

FREEZING WEATHER PRECAUTION: Subsequent to testing a piping system, valves should be left in an open position to allow complete drainage.

250 PSI CWP Iron Body Gate Valve

Bolted bonnet • non-rising stem • resilient wedge

250 PSI/17.2 bar non-shock cold working pressure

CONFORMS TO AWWA C509

EPOXY MEETS OR EXCEEDS AWWA C550

END CONNECTIONS DESIGNED FOR USE WITH C900 PVC PIPE

CERTIFIED LEAD-FREE* BY IAPMO R&T TO NSF/ANSI 372



FPCR-619-RW

MATERIAL LIST

PART	SPECIFICATION
1. Valve Body	Ductile Iron ASTM A536
2. Resilient Wedge	Ductile Iron Encapsulated by EPDM ASTM D 2000
3. Wedge Nut	Bronze ASTM B584 Alloy C83600
4. Stem	Aluminum Bronze ASTM B 150 Alloy C61400
5. Bonnet Gasket	EPDM ASTM D 2000
6. Bonnet Screw	18-8 Stainless Steel ASTM 193
7. Bonnet	Ductile Iron ASTM A536
8. Stem Primary O-Ring	EPDM ASTM D 2000
9. Stem Thrust Washer (lower)	Bronze ASTM B584
10. Stem Thrust Washer (upper)	Stainless Steel ASTM A 276 UNS S 41000
11. Gland Seal O-Ring	EPDM ASTM D 2000
12. Stem Seal Bushing	Bronze ASTM B584
13. Stem Secondary O-Ring (2)	EPDM ASTM D 2000
14. Gland Flange	Ductile Iron ASTM A536
15. Wiper Ring - Stem	EPDM ASTM D 2000
16. Nut, Wrench - Square	Iron ASTM A126-B
17. Washer, Wrench Nut	Carbon Steel, DIN 9021 B
18. Screw WR Nut	Alloy Steel ASTM A 574 M Zinc Plated
19. Screw, Gland Flange	Alloy Steel ASTM A 574 M Zinc Plated
20. Handwheel (Optional)	Ductile ASTM A536 (not pictured)

Coating — Electrostatically applied fusion-bonded epoxy 8-20 mil. inside and outside. Meets or exceeds performance requirements of AWWA C550. Epoxy coating is not intended to serve as a dielectric barrier internal to the piping system.
Maximum operating temperature 160°F/71°C.

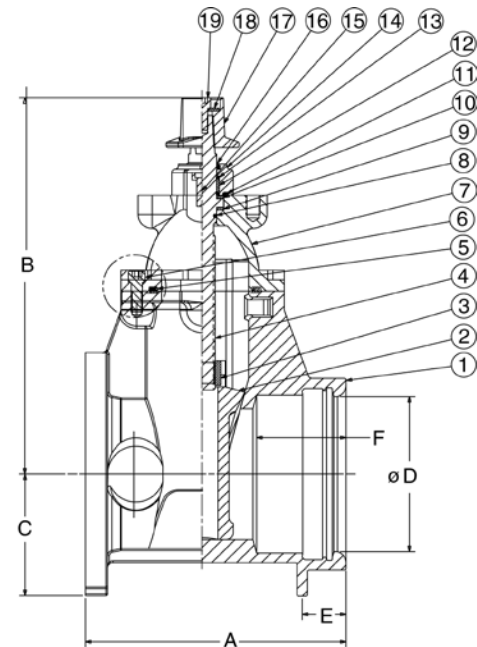

DIMENSIONS—WEIGHTS—QUANTITIES

Size	Dimensions						Hand Wheel (Optional)	Bolt Circle	Flange Holes	Turns to Open	Weight
	A	B	C	D	E	F					
In. mm.	In. mm.	In. mm.	In. mm.	In. mm.	In. mm.	In. mm.	In. mm.	In. mm.	In. mm.	Lbs. Kg.	
4 100	9.8 250	13.5 342	4.5 115	4.9 125	1.8 46	3.5 89	10.2 260	7.50 191	8	13.0 70	32
6 150	11.7 297	17.0 432	5.5 140	7.0 178	2.0 50	4.0 102	14.8 375	9.50 241	8	15.6 117	53
8 200	13.5 344	20.4 519	6.8 172	9.2 233	2.5 64	4.5 114	14.8 375	11.75 298	8	17.3 198	90
10 250	15.0 381	23.8 605	8.0 203	11.2 285	2.4 60	5.2 132	15.7 400	14.25 362	12	21.4 297	135
12 300	16.0 406	27.0 686	9.5 242	13.3 338	2.5 64	5.5 140	19.7 500	17.00 432	12	25.3 429	195

*Weighted average lead content ≤ 0.25%

VISIT WWW.NIBCO.COM FOR CURRENT CHEM-GUIDE AND GALVANIC POTENTIAL IN PIPING SYSTEMS INFORMATION.

Visit our website for the most current information.

FREEZING WEATHER PRECAUTION: Subsequent to testing a piping system, valves should be left in an open position to allow complete drainage.

Class 250 Iron Body Gate Valves

Bolted bonnet • outside screw and yoke • solid wedge • bronze mounted

500 PSI/34.5 bar non-shock cold working pressure to -20°F to 150°F/-29°C to 66°C*

Maximum working temperature 450°F/232°C at 250 PSI/17.2 bar

250 PSI/17.2 bar saturated steam to 406°F/208°C

CONFORMS TO MSS SP-70 • APPROVED BY THE NEW YORK CITY B.S.A. 143-69-SA AT 350 PSI NON-SHOCK COLD WATER

MATERIAL LIST

PART	SPECIFICATION
1. Stem	Brass ASTM B16 Alloy C36000
2. Handwheel Nut	Brass ASTM B584 Alloy C84400
3. Identification Plate	Aluminum
4. Yoke Bushing	Brass ASTM B584 Alloy C84400
5. Handwheel	Cast Iron ASTM A126 Class B
6. Bonnet Cap Nut	Steel ASTM A563
7. Bonnet Cap	Ductile Iron ASTM A536
8. Bonnet ¹	Cast Iron ASTM A126 Class B
9. Bonnet Cap Bolt	Steel ASTM A307/SAE J429
10. Gland Follower Nut	Brass ASTM F467 Alloy C27000
11. Gland Follower	Ductile Iron ASTM A536
12. Packing Gland	Zinc Plated Powdered Iron ASTM B783 or Brass ASTM B16 Alloy C3600
13. Packing	PTFE Braided Synthetic Fiber
14. Gland Follower Bolt	Steel ASTM A307/SAE J429
15. Backseat Bushing	Brass ASTM B584 Alloy C84400
16. Body Nut	Steel ASTM A563
17. Body Gasket	Reinforced Graphite
18. Body Bolt	Steel ASTM A307/SAE J429
19. Body	Cast Iron ASTM A126 Class B
20. Stem Collar	Brass ASTM B16 Alloy C36000
21. Wedge ²	Cast Iron ASTM A126 Class B
22. Wedge Nut ³	Brass ASTM B584 Alloy C84400
23. Wedge Pin	ASTM B140 Alloy C31400
24. Seat Ring	Brass ASTM B584 Alloy C84400
25. Wedge Face Ring ²	Brass ASTM B584 Alloy C84400

¹Sizes 2" thru 8" made with Yoke Integral with Bonnet. Sizes 8" thru 12" made with separate Yoke Bolted to Bonnet.

²Wedge construction - 2" thru 4" all bronze.

- 5" thru 12" Cast Iron with Bronze Wedge Face Rings.

³Bronze Wedge Nuts used on sizes 5" thru 12".

DIMENSIONS—WEIGHTS—QUANTITIES

Size	Dimensions										Weight	
	A		B		C		D		E		Lbs.	Kg.
In. mm.	In. mm.	In. mm.	In. mm.	In. mm.	In. mm.	In. mm.	In. mm.	In. mm.	In. mm.			
2 50	8.50 216	16.00 406	8 203	6.50 165	.88 22	56 25						
2½ 65	9.50 241	18.44 468	8 203	7.50 191	1.00 25	74 34						
3 80	11.13 283	20.50 521	10 254	8.25 210	1.13 29	122 55						
4 100	12.00 305	27.00 686	12 305	10.00 254	1.25 32	193 87						
5 125	15.00 381	31.50 800	12 305	11.00 279	1.38 35	297 135						
6 150	15.88 403	33.00 838	16 406	12.50 318	1.44 37	411 187						
8 200	16.50 419	45.50 1156	16 406	15.00 381	1.63 41	637 289						
10 250	18.00 457	56.00 1422	20 508	17.50 445	1.88 48	897 407						
12 300	19.75 502	60.00 1524	20 508	20.50 521	2.00 51	1172 532						



F-667-0
Flanged

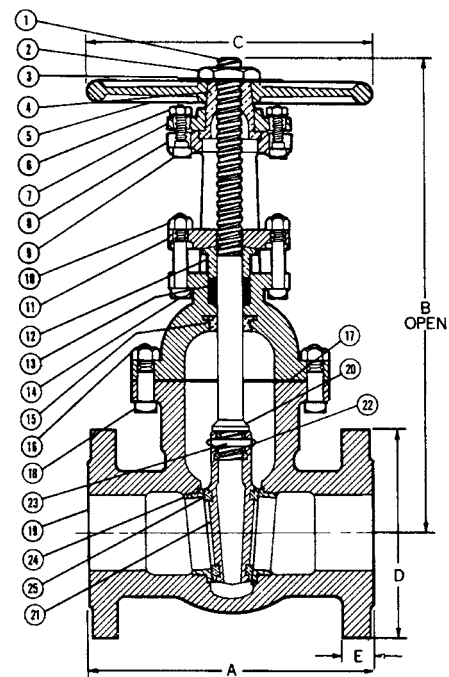

F-667-0
Flg x Flg

FREEZING WEATHER PRECAUTION: Subsequent to testing a piping system, valves should be left in an open position to allow complete drainage.

◆For detailed Operating Pressure, refer to Pressure Temperature Chart on page 114.

VISIT WWW.NIBCO.COM FOR CURRENT CHEM-GUIDE AND GALVANIC POTENTIAL IN PIPING SYSTEMS INFORMATION.

Visit our website for the most current information.

Class 250 Iron Body Gate Valves

Bolted bonnet • non-rising stem • solid wedge • bronze mounted

500 PSI/34.5 bar non-shock cold working pressure to -20°F to 150°F/-29°C to 66°C
Maximum working temperature 450°F/232°C at 250 PSI/17.2 bar
250 PSI/17.2 bar saturated steam to 406°F/208°C

CONFORMS TO MSS SP-70

MATERIAL LIST

PART	SPECIFICATION
1. Handwheel Nut	Steel ASTM A563
2. Identification Plate	Aluminum
3. Handwheel	Cast Iron ASTM A126 Class B
4. Stem	Brass ASTM B16 Alloy C36000
5. Gland Follower Nut	Brass ASTM F 467 Alloy C27000
6. Gland Follower	Cast Iron ASTM A126 Class B or Ductile Iron ASTM A536
7. Gland Follower Bolt	Steel ASTM A307/SAE J429
8. Packing Gland	Zinc Plated Powdered Iron ASTM B783 or Brass ASTM B16
9. Stuffing Box	Cast Iron ASTM A126 Class B
10. Packing	PTFE Braided
11. Stuffing Box Gasket	Reinforced Graphite
12. Stuffing Box Bolt	Steel ASTM A307/SAE J429
13. Stuffing Box Nut	Steel ASTM A563
14. Body Bolt	Steel ASTM A307/SAE J429
15. Bonnet	Cast Iron ASTM A126 Class B
16. Body Gasket	Reinforced Graphite
17. Body Nut	Steel ASTM A307
18. ² Wedge Nut	Brass ASTM B584 Alloy C84400
19. Seat Ring	Brass ASTM B584 Alloy C84400
20. ¹ Wedge Face Ring	Brass ASTM B584 Alloy C84400
21. ¹ Wedge	Cast Iron ASTM A126 Class B
22. Body	Cast Iron ASTM A126 Class B

¹Sizes thru 3" have Bronze Wedges. 4" thru 12" have Cast Iron Wedges with Bronze Wedge Face Rings.

²Bronze Wedge Bushing cast in place on 4" Wedge. Bronze Wedge Nut used in sizes 5" thru 12".



F-669
Flanged

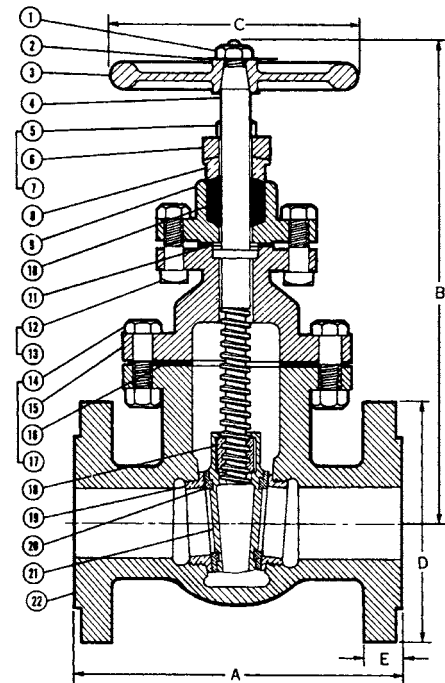

F-669
Flg x Flg

DIMENSIONS—WEIGHTS—QUANTITIES

Size	Dimensions										Weight		
	A		B		C		D		E		Lbs.	Kg.	
In. mm.	In.	mm.	In.	mm.	In.	mm.	In.	mm.	In.	mm.			
2	50	8.50	216	13.50	343	7	178	6.50	165	.88	22	53	24
2½	65	9.50	241	15.00	381	8	203	7.50	191	1.00	25	72	33
3	80	11.13	283	16.50	419	10	254	8.25	210	1.13	29	115	52
4	100	12.00	305	18.50	470	12	305	10.00	254	1.25	32	186	85
5	125	15.00	381	20.75	527	12	305	11.00	279	1.38	35	269	122
6	150	15.88	403	24.00	610	16	406	12.50	318	1.44	37	374	170
8	200	16.50	419	28.50	724	16	406	15.00	381	1.63	41	581	264
10	250	18.00	457	34.00	864	18	457	17.50	445	1.88	48	786	357
12	300	19.75	502	36.00	914	20	508	20.50	521	2.00	51	1098	498

Position indicators available. See page 98

FREEZING WEATHER PRECAUTION: Subsequent to testing a piping system, valves should be left in an open position to allow complete drainage.

◆ For detailed Operating Pressure, refer to Pressure Temperature Chart on page 114.

VISIT WWW.NIBCO.COM FOR CURRENT CHEM-GUIDE AND GALVANIC POTENTIAL IN PIPING SYSTEMS INFORMATION.

Visit our website for the most current information.

Iron Globe and Angle Valves Illustrated Index

Iron Body Globe Valve
Outside Screw and Yoke
125 lb. SWP
200 lb. CWP



F-718-B Brass Disc
F-718-N All Iron Trim
Sizes 2" thru 10" Flanged
Page 54, 55

Iron Body Globe Valve
Outside Screw and Yoke • Bronze Mounted
250 lb. SWP
500 lb. CWP



F-768-B
Brass Disc
Sizes 2" thru 8" Flanged
Page 56

Iron Body Angle Valve
Outside Screw and Yoke • Bronze Mounted
125 lb. SWP
200 lb. CWP



F-818-B
Brass Disc
Sizes 2" thru 8" Flanged
Page 57

Iron Body Stop Check Valve
Outside Screw and Yoke • Bronze Mounted
250 lb. SWP
500 lb. CWP



F-869-B
Brass Disc
Sizes 2½" thru 8" Flanged
Page 58

VISIT WWW.NIBCO.COM FOR CURRENT CHEM-GUIDE AND GALVANIC POTENTIAL IN PIPING SYSTEMS INFORMATION.

Visit our website for the most current information.

Class 125 Iron Body Globe Valves

Bolted bonnet • renewable seat and disc* • bronze mounted

200 PSI/13.8 bar non-shock cold working pressure to -20°F to 150°F/-29°C to 66°C†

Maximum working temperature 450°F/232°C at 125 PSI/8.6 bar

125 PSI/8.6 bar saturated steam to 353°F/178°C

CONFORMS TO MSS SP-85

MATERIAL LIST

PART	SPECIFICATION
1. Handwheel Nut	Steel ASTM A307
2. Identification Plate	Aluminum
3. Handwheel	Cast Iron ASTM A126 Class B
4. Yoke Bushing	Brass ASTM B584 Alloy C84400
5. Bonnet	Cast Iron ASTM A126 Class B
6. Stem	Brass ASTM B16 Alloy C36000
7. Gland Follower Nut	Brass ASTM F467 Alloy C27000
8. Gland Follower	Cast Iron ASTM A126 Class B or Ductile Iron ASTM A536
9. Packing Gland	Zinc Plated Powdered Iron ASTM B783 or Brass ASTM B16
10. Gland Follower Stud	Steel ASTM A307
11. Packing	Synthetic Fibers with Graphite
12. ¹ Body Bolt	Steel ASTM A307/SAE J429
13. Body Gasket	Synthetic Fibers
14. ¹ Body Nut	Steel ASTM A563
15. Swivel Nut	Brass ASTM B584 Alloy C84400
16. ² Disc Cage	Cast Iron ASTM A126 Class B
17. ³ Disc	Brass ASTM B584 Alloy C84400 (B)
**18. ⁴ Disc Plate	Cast Iron ASTM A126 Class B
**19. Disc Nut	Bronze
20. Seat Ring	Brass ASTM B584 Alloy C84400
21. Body	Cast Iron ASTM A126 Class B

¹2" and 10" have hex head steel capscrew.

²2" thru 5" are Cast Bronze ASTM B584 Alloy C84400

³For (B) Disc, 2" thru 6" have Bronze ASTM B584 Alloy C84400 Disc.

8" thru 10" have Iron Disc with Bronze Disc Face Rings and Brass Pilots.

⁴2" thru 4" are Cast Bronze ASTM B584 Alloy C84400.

**For PTFE Seat Valves Only.

DIMENSIONS—WEIGHTS—QUANTITIES

Size	Dimensions										Weight		
	A		B		C		D		E		Lbs.	Kg.	
In. mm.	In. mm.	In. mm.	In. mm.	In. mm.	In. mm.	In. mm.	In. mm.	In. mm.	In. mm.	Lbs.	Kg.		
2	50	8.00	203	10.19	259	7	178	6.00	152	.63	16	32	15
2½	65	8.50	216	11.81	300	8	203	7.00	178	.69	17	49	22
3	80	9.50	241	12.50	318	8	203	7.50	191	.75	19	65	30
4	100	11.50	292	15.81	402	10	254	9.00	229	.94	24	98	44
5	125	13.00	330	16.50	419	10	254	10.00	254	.94	24	140	63
6	150	14.00	356	18.88	479	12	305	11.00	279	1.00	25	182	83
8	200	19.50	495	21.13	537	16	406	13.50	343	1.13	29	361	164
10	250	24.50	622	25.19	640	18	457	16.00	406	1.19	30	586	266

*With proper machining facilities.



F-718-B

Flanged

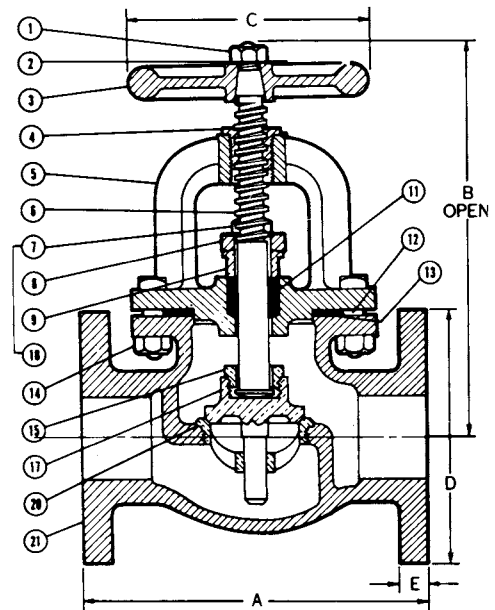

F-718-B

Flg x Flg

FREEZING WEATHER PRECAUTION: Subsequent to testing a piping system, valves should be left in an open position to allow complete drainage.

◆ For detailed Operating Pressure, refer to Pressure Temperature Chart on page 114.

VISIT WWW.NIBCO.COM FOR CURRENT CHEM-GUIDE AND GALVANIC POTENTIAL IN PIPING SYSTEMS INFORMATION.

Visit our website for the most current information.

Class 125 All Iron Trim Iron Body Globe Valves

Bolted bonnet • renewable seat and disc*

200 PSI/13.8 bar non-shock cold working pressure to -20°F to 150°F/-29°C to 66°C
Maximum working temperature 450°F/232°C at 125 PSI/8.6 bar
125 PSI/8.6 bar saturated steam to 353°F/178°C

CONFORMS TO MSS SP-85

MATERIAL LIST

PART	SPECIFICATION
1. Handwheel Nut	Steel ASTM A563
2. Identification Plate	Aluminum
3. Handwheel	Cast Iron ASTM A126 Class B
4. Yoke Bushing	Ductile Iron ASTM A536
5. Bonnet	Cast Iron ASTM A126 Class B
6. Stem	Steel ASTM A108 12L14 Electroless NI-PI
7. Gland Follower Nut	Steel ASTM A307/SAE J429
8. Gland Follower	Cast Iron ASTM A126 Class B or Ductile Iron ASTM A536
9. Packing Gland	Zinc Plated Powdered Iron ASTM B783
10. Gland Follower Stud	Steel ASTM A307/SAE J429
11. Packing	PTFE Braided
12. ¹ Body Bolt	Steel ASTM A307/SAE J429
13. Body Gasket	Synthetic Fibers
14. ¹ Body Nut	Steel ASTM A563
15. Swivel Nut	Cast Iron ASTM A126 Class B
16. Disc	Cast Iron ASTM A126 Class B
17. Seat Ring	Cast Iron ASTM A126 Class B
18. Body	Cast Iron ASTM A126 Class B

¹2" and 10" have hex head steel capscrew.



F-718-N
Flanged

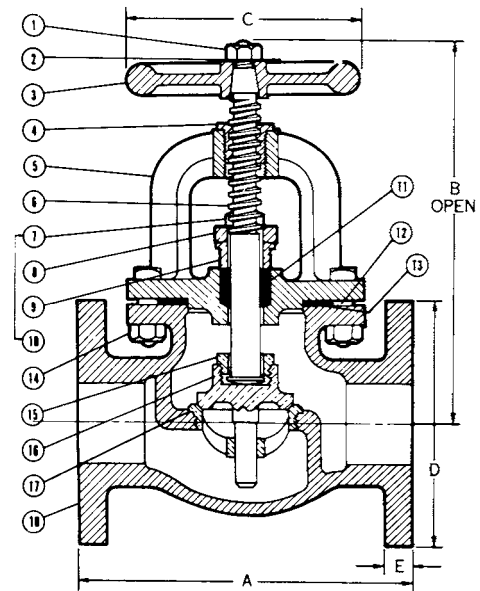

F-718-N
Flg x Flg

DIMENSIONS—WEIGHTS—QUANTITIES

Size	Dimensions										Weight		
	In.	mm.	A	B	C	D	E	In.	mm.	In.	mm.	Lbs.	Kg.
2	50	8.00	203	10.19	259	7	178	6.00	152	.63	16	33	15
2½	65	8.50	216	11.81	300	8	203	7.00	178	.69	17	49	22
3	80	9.50	241	12.50	318	8	203	7.50	191	.75	19	66	30
4	100	11.50	292	15.81	402	10	254	9.00	229	.94	24	97	44
5	125	13.00	330	16.50	419	10	254	10.00	254	.94	24	141	64
6	150	14.00	356	18.88	479	12	305	11.00	279	1.00	25	183	83
8	200	19.50	495	21.13	537	16	406	13.50	343	1.13	29	359	163
10	250	24.50	622	25.19	640	18	457	16.00	406	1.19	30	611	277

*With proper machining facilities available.

FREEZING WEATHER PRECAUTION: Subsequent to testing a piping system, valves should be left in an open position to allow complete drainage.

◆ For detailed Operating Pressure, refer to Pressure Temperature Chart on page 114.

VISIT WWW.NIBCO.COM FOR CURRENT CHEM-GUIDE AND GALVANIC POTENTIAL IN PIPING SYSTEMS INFORMATION.

Visit our website for the most current information.

Class 250 Iron Body Globe Valves

Bolted bonnet • renewable seat and disc* • bronze mounted

500 PSI/34.5 bar non-shock cold working pressure from -20°F to 150°F/-29°C to 66°C♦

Maximum working temperature 450°F/232°C at 250 PSI/17.2 bar

250 PSI/17.2 bar saturated steam to 406°F/208°C

CONFORMS TO MSS SP-85

MATERIAL LIST

PART	SPECIFICATION
1. Handwheel Nut	Steel ASTM A563
2. Identification Plate	Aluminum
3. Handwheel	Cast Iron ASTM A126 Class B
4. Stem	Brass ASTM B16 Alloy C36000
5. Yoke Bushing	Brass ASTM B584 Alloy C84400
6. Bonnet	Cast Iron ASTM A126 Class B
7. Gland Follower Nut	Brass ASTM F467 Alloy C27000
8. Gland Follower Stud	Steel ASTM A307/SAE J429
9. Gland Follower	Cast Iron ASTM A126 Class B or Ductile Iron ASTM A536
10. Packing Gland	Zinc Plated Powdered Iron ASTM B783 or Brass ASTM B16
11. Hex Head Cap Screw	Steel ASTM A307/SAE J429
12. Packing	PTFE Braided
13. Body Gasket	Reinforced Graphite
14. Swivel Nut	Brass ASTM B584 Alloy C84400 or ASTM B16 Alloy C36000
15. ¹ Disc	Cast Iron ASTM A126 Class B
16. Disc Ring	Brass ASTM B584 Alloy C84400
17. Disc Pilot	Brass ASTM B584 Alloy C84400
18. Seat Ring	Brass ASTM B584 Alloy C84400
19. Body	Cast Iron ASTM A126 Class B

†Sizes thru 4" have all Bronze Discs

Sizes 6" and 8" have Cast Iron Disc with Bronze Disc Face Rings and Brass Pilots.

DIMENSIONS—WEIGHTS—QUANTITIES

Size	Dimensions										Weight		
	A		B		C		D		E		Lbs.	Kg.	
In. mm.	In.	mm.	In.	mm.	In.	mm.	In.	mm.	In.	mm.			
2	50	10.50	267	10.31	262	7	178	6.50	165	.88	22	42	19
2½	65	11.50	292	13.56	344	8	203	7.50	191	1.00	25	78	35
3	80	12.50	318	14.00	356	10	254	8.25	210	1.13	29	96	44
4	100	14.00	356	16.50	419	11	279	10.00	254	1.25	32	154	70
6	150	17.50	445	23.50	597	14	356	12.50	318	1.44	37	360	163
8	200	21.00	533	26.50	673	16	406	15.00	381	1.63	41	546	248

*With proper machining facilities available.



F-768-B
Flanged

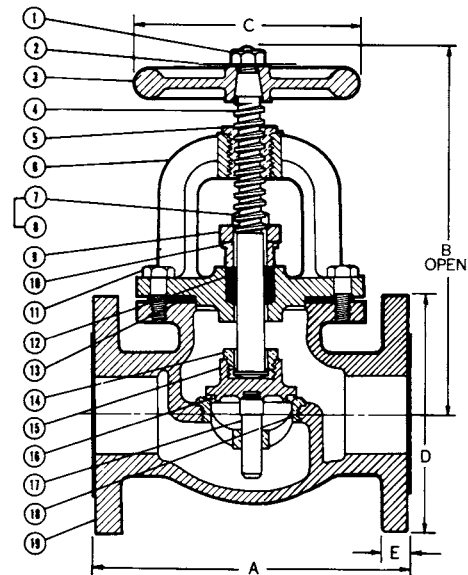

F-768-B
Fig x Fig

FREEZING WEATHER PRECAUTION: Subsequent to testing a piping system, valves should be left in an open position to allow complete drainage.

♦ For detailed Operating Pressure, refer to Pressure Temperature Chart on page 114.

VISIT WWW.NIBCO.COM FOR CURRENT CHEM-GUIDE AND GALVANIC POTENTIAL IN PIPING SYSTEMS INFORMATION.

Visit our website for the most current information.

Class 125 Iron Body Angle Valves

Bolted bonnet • renewable seat and disc* • bronze mounted

200 PSI/13.8 bar non-shock cold working pressure to -20°F to 150°F/-29°C to 66°C

Maximum working temperature 450°F/232°C at 125 PSI/8.6 bar

125 PSI/8.6 bar saturated steam to 353°F/178°C

CONFORMS TO MSS SP-85

MATERIAL LIST

PART	SPECIFICATION
1. Handwheel Nut	Steel ASTM A563
2. Identification Plate	Aluminum
3. Handwheel	Cast Iron ASTM A126 Class B
4. Yoke Bushing	Brass ASTM B584 Alloy C84400
5. Bonnet	Cast Iron ASTM A126 Class B
6. Stem	Brass ASTM B16 Alloy C36000
7. Gland Follower Nut	Brass ASTM F467 Alloy C27000
8. Gland Follower Stud	Steel ASTM A307/SAE J429
9. Gland Follower	Cast Iron ASTM A126 Class B or Ductile Iron ASTM A536
10. Packing Gland	Zinc Plated Powdered Iron ASTM B783 or ASTM B16
11. Packing	Synthetic Fibers with Graphite
12. ¹ Body Bolt	Steel ASTM A307/SAE J429
13. Body Gasket	Synthetic Fibers
14. ¹ Body Nut	Steel ASTM A563
15. Swivel Nut	Brass ASTM B584 Alloy C84400
16. ² Disc Cage	Cast Iron ASTM A126 Class B
17. ³ Disc	Bronze ASTM B584 Alloy C84400 (B)
18. ⁴ Disc Plate	Cast Iron ASTM A126 Class B
19. Disc Nut	Bronze
20. Seat Ring	Brass ASTM B584 Alloy C84400
21. Body	Cast Iron ASTM A126 Class B

¹ 2" have hex head steel capscrews.

² 2" thru 5" are Cast Bronze ASTM B584 Alloy C84400.

³ 8" have Cast Iron Disc with Bronze Disc Face Rings and Brass Pilots.

⁴ 2" thru 4" are Cast Bronze ASTM B584 Alloy C84400.

DIMENSIONS—WEIGHTS—QUANTITIES

Size	Dimensions										Weight		
	A		B		C		D		E		Lbs.	Kg.	
In. mm.	In.	mm.	In.	mm.	In.	mm.	In.	mm.	In.	mm.			
2	50	4.00	102	10.00	254	7	178	6.00	152	.63	16	30	14
2½	65	4.25	108	11.50	292	8	203	7.00	178	.69	17	50	23
3	80	4.75	121	12.25	311	8	203	7.50	191	.75	19	60	27
4	100	5.75	146	15.00	381	10	254	9.00	229	.94	24	99	45
5	125	6.50	171	16.50	419	10	254	10.00	254	.94	24	133	60
6	150	7.00	178	18.88	479	12	305	11.00	279	1.00	25	187	85
8	200	9.75	248	20.75	527	16	406	13.50	343	1.13	29	349	158

*With proper machining facilities available.



F-818-B
Flanged

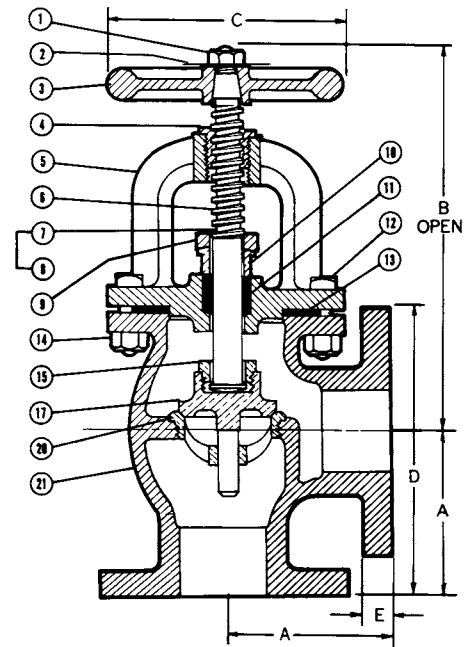

F-818-B
Flg x Flg

FREEZING WEATHER PRECAUTION: Subsequent to testing a piping system, valves should be left in an open position to allow complete drainage.

◆ For detailed Operating Pressure, refer to Pressure Temperature Chart on page 114.

VISIT WWW.NIBCO.COM FOR CURRENT CHEM-GUIDE AND GALVANIC POTENTIAL IN PIPING SYSTEMS INFORMATION.

Visit our website for the most current information.

Class 250 Iron Body Automatic Stop Check Valves

Bolted bonnet • angle pattern • renewable seat and disc* • bronze mounted

500 PSI/34.5 bar non-shock cold working pressure from -20°F to 150°F/-29°C to 66°C†

Maximum working temperature 450°F/232°C at 250 PSI/17.2 bar

250 PSI/17.2 bar saturated steam to 406°F/208°C

CONFORMS TO MSS SP-85

MATERIAL LIST

PART	SPECIFICATION
1. Handwheel Nut	Steel ASTM A307
2. Identification Plate	Aluminum
3. Handwheel	Cast Iron ASTM A126 Class B
4. Stem	Brass ASTM B 16 Alloy C36000
5. Yoke Bushing	Brass ASTM B584 Alloy C84400
6. Bonnet	Cast Iron ASTM A126 Class B
7. Gland Follower Stud	Steel ASTM A307 (not shown)
8. Gland Follower Nut	Brass ASTM F467 Alloy C27000 (not shown)
9. Gland Follower	Ductile Iron ASTM A536
10. Packing Gland	Zinc Plated Powdered Iron ASTM B783 or Brass ASTM B16
11. Packing	PTFE Braided
12. 1 Butterfly Handle Nut	Steel ASTM A307/SAE J429
13. 1 Butterfly Handle	Brass ASTM B584 Alloy C84400
14. 1 Control Valve Stem	Bronze ASTM B371 Alloy C69400
15. 1 Control Valve Pack Nut	Brass ASTM B584 Alloy C84400
16. 1 Control Valve Pack Gland	Brass ASTM B16 Alloy C36000
17. 1 Control Valve Packing	Synthetic Fibers with Graphite
18. 1 Control Valve Body	Brass ASTM B584 Alloy C84400
19. Hex Head Cap Screw	Steel ASTM A307/SAE J429
20. Body Gasket	Reinforced Graphite
21. 1 Dashpot Gasket	Reinforced Graphite
22. 1 Dashpot	Brass ASTM B584 Alloy C84400
23. 1 Piston-Disc	Cast Iron ASTM A126 Class B
24. 1 Piston Ring (2)	PTFE Composite Material
25. 1 Disc Face Ring	Brass ASTM B584 Alloy C84400
26. 1 Seat Ring	Brass ASTM B584 Alloy C84400
27. Body	Cast Iron ASTM A126 Class B
28. 2 Piston Ring Collar	Brass ASTM B16 Alloy C36000
29. 2 Disc Cage	Brass ASTM B584 Alloy C84400
30. 2 PTFE Disc	PTFE
31. 2 Disc Plate and Nut	Brass ASTM B584 C84400
32. 2 Piston Rod Plug	Brass ASTM B16 Alloy C36000
33. 2 Piston Rod Plug Pin	Bronze ASTM B 140 Alloy C31400

†4" thru 8" size only. (4" thru 8" have Cast Iron Disc with Bronze Disc Face Ring)
‡TFE Seat Disc in 2½" and 3" only. Maximum 150 psi saturated steam working pressure

DIMENSIONS—WEIGHTS—QUANTITIES

Size	Dimensions										Weight			
	In.	mm.	In.	mm.	In.	mm.	In.	mm.	In.	mm.	Lbs.	Kg.		
2½	65	1651	5.75	146	12.63	321	8	203	7.50	191	1.00	25	80	36
3	80	2032	6.25	159	14.00	356	10	254	8.25	210	1.13	29	102	46
4	100	2540	7.00	178	16.50	419	10	254	10.00	254	1.25	32	168	76
6	150	3810	8.75	222	20.75	527	14	356	12.50	318	1.44	37	311	141
8	200	5080	10.50	267	23.81	605	16	406	15.00	381	1.63	41	520	236

*With proper machining facilities available.
Valve must be installed vertically.



F-869-B
Flanged
Series D

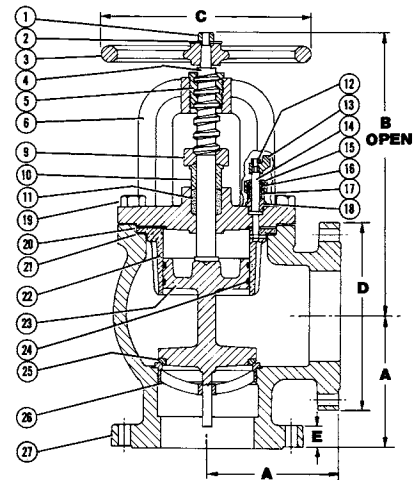

F-869-B
Flg x Flg

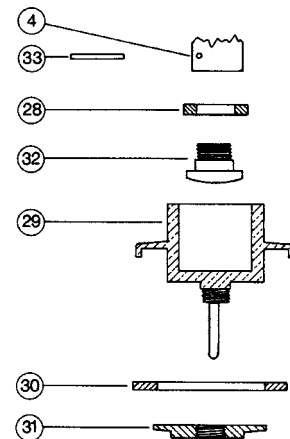

FREEZING WEATHER PRECAUTION: Subsequent to testing a piping system, valves should be left in an open position to allow complete drainage.

◆ For detailed Operating Pressure, refer to Pressure Temperature Chart on page 114.

VISIT WWW.NIBCO.COM FOR CURRENT CHEM-GUIDE AND GALVANIC POTENTIAL IN PIPING SYSTEMS INFORMATION.

Visit our website for the most current information.

Sizing NIBCO Automatic Stop Check Valves F-869-B

CALCULATED STEAM VOLUME SYSTEM REQUIREMENTS

HOUR	EXAMPLE 1 NORMAL VOLUME lbs/hr	EXAMPLE 2 WINTER VOLUME lbs/hr
12 AM	17,000	29,000
1	13,000	24,000
2	15,000	26,000
3	13,000	25,000
4	10,000	22,000
5	14,000	25,000
6	15,000	26,000
7	20,000	31,000
8	23,000	34,000
9	39,000	50,000
10	44,000	55,000
11	45,000	63,000
12 PM	40,000	51,000
1	22,000	32,000
2	35,000	46,000
3	37,000	49,000
4	34,000	45,000
5	35,000	45,000
6	33,000	44,000
7	33,000	44,000
8	34,000	46,000
9	29,000	43,000
10	27,000	40,000
11	20,000	33,000
DAILY TOTAL	647,000	928,000
HOURLY AVERAGE	26,958	38,667

STEP 1

- Calculate and chart the expected steam volume requirements for each hour of boiler operation. See example chart on left.
- Total the volume and divide by the number of hours the boiler is in operation to get steam Hourly Average volume in lbs/hour.

STEP 2

Example 1 - This is a typical boiler system where the steam volume is consistent throughout the year. Use the Sizing Chart below, left section with 2 psi pressure drop.

- Identify system steam working gauge pressure.
For our example we will use 125 psi.
- Use *Hourly Average* steam demand calculated in Step 1 above. For our example use 26,958 from chart on left, center column.
- Find the *Gauge Pressure* column in Sizing Chart below closest to the system pressure of our example, 125 psi, for each size valve (**120 psi** is closest).
- Find the *lbs/hr* in Sizing Chart below closest to calculated Hourly Average of our example, 26,958 lbs/hr (**23,100** is closest).
- Read across to choose a 6" size valve.

Example 2 - This is a typical boiler system where the steam volume is higher in the winter than in summer. Use the Sizing Chart below, right section with 5 psi pressure drop.

- Identify system steam working gauge pressure.
For our example we will use 125 psi.
- Use *Hourly Average* steam demand calculated in Step 1 above. For our example use 38,667 from chart on left, right column.
- Find the *Gauge Pressure* column in Sizing Chart below closest to the system pressure of our example, 125 psi, for each size valve (**120 psi** is closest).
- Find the *lbs/hr* in Sizing Chart below closest to calculated Hourly Average of our example, 38,667 lbs/hr (**37,400** is closest).
- Read across to choose a 6" size valve.

NOTE: It is better for control consistency to size the automatic stop check valve on the smaller side than on the larger side.

SIZING CHART

2 psi PRESSURE DROP for consistent steam volume						5 psi PRESSURE DROP for consistent steam volume					
STEAM VOLUME FLOW lbs/hr	SATURATED STEAM GAUGE PRESSURE				VALVE SIZE	STEAM VOLUME FLOW lbs/hr	SATURATED STEAM GAUGE PRESSURE				VALVE SIZE
	10 psi	50 psi	120 psi	250 psi			10 psi	50 psi	120 psi	250 psi	
	1,540	2,420	3,520	—	2½"		2,640	3,630	5,720	—	2½"
	2,200	3,520	4,840	—	3"		3,850	6,380	9,350	—	3"
	3,740	5,940	8,250	11,550	4"		7,150	11,000	16,500	23,100	4"
	9,900	15,400	23,100	33,000	6"		16,500	25,300	37,400	51,700	6"
16,500	27,500	38,500	55,000	8"	29,700	46,200	66,000	93,500	8"		

VISIT WWW.NIBCO.COM FOR CURRENT CHEM-GUIDE AND GALVANIC POTENTIAL IN PIPING SYSTEMS INFORMATION.

Visit our website for the most current information.

F-869 Automatic Stop Check Valve Sizing Guide

RATED BOILER HP	MAXIMUM BOILER CAPACITY (LBS/HR)	OPERATING PRESSURE (PSIG)									
		10	50	75	100	125	150	175	200	225	250
100	3450	4"	3"	3"	2½"	2½"	2½"	n/a	n/a		
125	4313	4"	3"	3"	3"	3"	2½"	n/a	n/a	n/a	n/a
150	5175	4"	4"	4"	3"	3"	3"	n/a	n/a	n/a	n/a
200	6900	6"	4"	4"	4"	4"	3"	n/a	n/a	n/a	n/a
250	8625	6"	4"	4"	4"	4"	4"	4"	n/a	n/a	n/a
300	10350	6"	4"	4"	4"	4"	4"	4"	4"	4"	4"
350	12075	6"	6"	4"	4"	4"	4"	4"	4"	4"	4"
400	13800	8"	6"	6"	4"	4"	4"	4"	4"	4"	4"
500	17250	8"	6"	6"	6"	6"	4"	4"	4"	4"	4"
600	20700		8"	6"	6"	6"	6"	6"	4"	4"	4"
700	24150		8"	6"	6"	6"	6"	6"	6"	6"	6"
750	25875		8"	8"	6"	6"	6"	6"	6"	6"	6"
800	27600		8"	8"	8"	6"	6"	6"	6"	6"	6"
900	31050		8"	8"	8"	8"	6"	6"	6"	6"	6"
1000	34500		8"	8"	8"	8"	8"	6"	6"	6"	6"
1100	37950			8"	8"	8"	8"	8"	6"	6"	6"
1200	41400			8"	8"	8"	8"	8"	8"	6"	6"
1300	44850				8"	8"	8"	8"	8"	8"	8"
1400	48300				8"	8"	8"	8"	8"	8"	8"
1500	51750					8"	8"	8"	8"	8"	8"
1600	55200						8"	8"	8"	8"	8"
1800	62100							8"	8"	8"	8"
2000	69000								8"	8"	8"

This chart assumes that the boiler will always run at maximum capacity (lbs/hr)

RATED BOILER HP	@ 90% BOILER CAPACITY (LBS/HR)	OPERATING PRESSURE (PSIG)									
		10	50	75	100	125	150	175	200	225	250
100	3105	4"	3"	2½"	2½"	2½"	2½"	n/a	n/a		
125	3881	4"	3"	3"	3"	2½"	2½"	n/a	n/a	n/a	n/a
150	4658	4"	3"	3"	3"	3"	3"	n/a	n/a	n/a	n/a
200	6210	4"	4"	4"	3"	3"	3"	n/a	n/a	n/a	n/a
250	7763	6"	4"	4"	4"	4"	3"	n/a	n/a	n/a	n/a
300	9315	6"	4"	4"	4"	4"	4"	4"	n/a	n/a	n/a
350	10868	6"	6"	4"	4"	4"	4"	4"	4"	4"	4"
400	12420	6"	6"	4"	4"	4"	4"	4"	4"	4"	4"
500	15525	8"	6"	6"	4"	4"	4"	4"	4"	4"	4"
600	18630	8"	6"	6"	6"	6"	4"	4"	4"	4"	4"
700	21735		8"	6"	6"	6"	6"	6"	6"	4"	4"
750	23288		8"	6"	6"	6"	6"	6"	6"	6"	6"
800	24840		8"	8"	6"	6"	6"	6"	6"	6"	6"
900	27945		8"	8"	6"	6"	6"	6"	6"	6"	6"
1000	31050		8"	8"	8"	6"	6"	6"	6"	6"	6"
1100	34155		8"	8"	8"	8"	6"	6"	6"	6"	6"
1200	37260			8"	8"	8"	8"	6"	6"	6"	6"
1300	40365			8"	8"	8"	8"	8"	6"	6"	6"
1400	43470			8"	8"	8"	8"	8"	8"	6"	6"
1500	46575				8"	8"	8"	8"	8"	8"	8"
1600	49680				8"	8"	8"	8"	8"	8"	8"
1800	55890					8"	8"	8"	8"	8"	8"
2000	62100						8"	8"	8"	8"	8"

This chart assumes that the boiler will always run between 75% and 100% of maximum capacity (lbs/hr) and average an output of 90% of boiler capacity.

- NOTES:
1. Automatic Stop Check Valve sizing must be sized only to the boiler steam demand, not the boiler nozzle outlet piping size.
 2. Specific operating conditions may require slightly different Automatic Stop Check Valve sizing requirements for any given boiler system.
 3. Automatic Stop Check Valve sizing is based on a target of 2 PSI pressure drop across the valve for optimum flow.
 4. Please contact NIBCO Technical Services for guidance if operating conditions differ from conditions stated in #2 above.
 5. This chart is to be used to assist in sizing Automatic Stop Check Valves, NIBCO assumes no liability for incorrect sizing.

F-869 Automatic Stop Check Valve Sizing Guide

RATED BOILER HP	@ 75% BOILER CAPACITY (LBS/HR)	OPERATING PRESSURE (PSIG)									
		10	50	75	100	125	150	175	200	225	250
100	2588	3"	2½"	2½"	2½"	2½"	2½"	n/a			
125	3234	4"	3"	2½"	2½"	2½"	2½"	n/a	n/a		
150	3881	4"	3"	3"	2½"	2½"	2½"	n/a	n/a	n/a	n/a
200	5175	4"	4"	3"	3"	3"	3"	n/a	n/a	n/a	n/a
250	6469	4"	4"	4"	3"	3"	3"	n/a	n/a	n/a	n/a
300	7763	6"	4"	4"	4"	4"	3"	n/a	n/a	n/a	n/a
350	9056	6"	4"	4"	4"	4"	4"	4"	n/a	n/a	n/a
400	10350	6"	4"	4"	4"	4"	4"	4"	4"	4"	4"
500	12938	6"	6"	4"	4"	4"	4"	4"	4"	4"	4"
600	15525	8"	6"	6"	4"	4"	4"	4"	4"	4"	4"
700	18113	8"	6"	6"	6"	6"	4"	4"	4"	4"	4"
750	19406	8"	6"	6"	6"	6"	6"	4"	4"	4"	4"
800	20700		6"	6"	6"	6"	6"	6"	6"	4"	4"
900	23288		8"	6"	6"	6"	6"	6"	6"	6"	6"
1000	25875		8"	8"	6"	6"	6"	6"	6"	6"	6"
1100	28463		8"	8"	8"	6"	6"	6"	6"	6"	6"
1200	31050		8"	8"	8"	8"	6"	6"	6"	6"	6"
1300	33638		8"	8"	8"	8"	6"	6"	6"	6"	6"
1400	36225		8"	8"	8"	8"	8"	6"	6"	6"	6"
1500	38813			8"	8"	8"	8"	8"	6"	6"	6"
1600	41400			8"	8"	8"	8"	8"	8"	6"	6"
1800	46575				8"	8"	8"	8"	8"	8"	8"
2000	51750					8"	8"	8"	8"	8"	8"

This chart assumes that the boiler will always run between 50% and 100% of maximum capacity (lbs/hr) and average an output of 75% of boiler capacity.

RATED BOILER HP	@ 50% BOILER CAPACITY (LBS/HR)	OPERATING PRESSURE (PSIG)									
		10	50	75	100	125	150	175	200	225	250
100	1725	2½"									
125	2156	3"	2½"	2½"							
150	2588	3"	2½"	2½"	2½"	2½"					
200	3450	4"	3"	3"	2½"	2½"	2½"	n/a			
250	4313	4"	3"	3"	3"	3"	2½"	n/a	n/a	n/a	n/a
300	5175	4"	4"	4"	3"	3"	3"	n/a	n/a	n/a	n/a
350	6038	4"	4"	4"	4"	3"	3"	n/a	n/a	n/a	n/a
400	6900	6"	4"	4"	4"	4"	3"	n/a	n/a	n/a	n/a
500	8625	6"	4"	4"	4"	4"	4"	4"	n/a	n/a	n/a
600	10350	6"	4"	4"	4"	4"	4"	4"	4"	4"	4"
700	12075	6"	6"	4"	4"	4"	4"	4"	4"	4"	4"
750	12938	6"	6"	6"	4"	4"	4"	4"	4"	4"	4"
800	13800	8"	6"	6"	4"	4"	4"	4"	4"	4"	4"
900	15525	8"	6"	6"	6"	4"	4"	4"	4"	4"	4"
1000	17250	8"	6"	6"	6"	6"	4"	4"	4"	4"	4"
1100	18975		6"	6"	6"	6"	6"	4"	4"	4"	4"
1200	20700		6"	6"	6"	6"	6"	6"	6"	4"	4"
1300	22425		8"	6"	6"	6"	6"	6"	6"	6"	6"
1400	24150		8"	8"	6"	6"	6"	6"	6"	6"	6"
1500	25875		8"	8"	6"	6"	6"	6"	6"	6"	6"
1600	27600		8"	8"	8"	6"	6"	6"	6"	6"	6"
1800	31050		8"	8"	8"	8"	6"	6"	6"	6"	6"
2000	34500		8"	8"	8"	8"	8"	8"	6"	6"	6"

This chart assumes that the boiler will always run between 25% & 100% of maximum capacity (lbs/hr) and average an output of 50% of boiler capacity.

- NOTES:
1. Automatic Stop Check Valve sizing must be sized only to the boiler steam demand, not the boiler nozzle outlet piping size.
 2. Specific operating conditions may require slightly different Automatic Stop Check Valve sizing requirements for any given boiler system.
 3. Automatic Stop Check Valve sizing is based on a target of 2 PSI pressure drop across the valve for optimum flow.
 4. Please contact NIBCO Technical Services for guidance if operating conditions differ from conditions stated in #2 above.
 5. This chart is to be used to assist in sizing Automatic Stop Check Valves, NIBCO assumes no liability for incorrect sizing.

Iron Check Valves & Y-Strainers

Illustrated Index

<p>Iron Body Swing Check Valve Bronze Mounted or All Iron 125 lb. SWP 200 lb. CWP</p>  <p>F-918-B/F-918-N/T-918-B Bronze or Cast Iron Disc Sizes 2" thru 12" Flanged or Threaded Page 63, 64</p>	<p>Iron Body Swing Check Valve Bronze Mounted 250 lb. SWP 500 lb. CWP</p>  <p>F-968-B Bronze Disc Sizes 2½" thru 6" Flanged Page 65</p>	<p>Lead Free Iron Body Silent Check Valve In-Line Lift • Wafer Style • Spring Actuated 125 lb. Class/200 lb. CWP 250 lb. Class/400 lb. CWP</p>  <p>W-910-LF, 125 lb. Class W-960-LF, 250 lb. Class Bronze or Buna-N Seat Sizes 2" thru 10" Wafer Style Page 66</p>	<p>Lead Free Iron Body Silent Check Valve In-Line Lift • Globe Style • Spring Actuated 125 lb. Class/200 lb. CWP 250 lb. Class/400 lb. CWP</p>  <p>F-910-LF, 125 lb. Class F-960-LF, 250 lb. Class Bronze or Buna-N Seat Sizes 2 ½" thru 36" Flanged Page 67</p>
<p>Iron Body Twin Disk Check Valve 125 lb. Class/250 lb. CWP</p>  <p>W-920-W / W-920-W-LF Buna-N Seat Sizes 2" thru 36" Wafer Style Page 68, 69, 70</p>	<p>Lead Free Iron Body Grooved Silent Check Valve Bronze Disc 250 lb. CWP</p>  <p>G-920-W-LF Buna-N Seat Sizes 2" thru 12" Grooved Page 71</p>	<p>Iron Y-Strainer Screw-in Cap • Blow-off Plug Class 250</p>  <p>T-751-A 20 Mesh or SS Perforated Screen Sizes 1/4" - 3" Threaded Page 72</p>	<p>Iron Y-Strainer Bolted Bonnet • Blow-off Plug Class 125</p>  <p>F-721-A 20 Mesh or SS Perforated Screen Sizes 2" - 16" Flanged Page 73</p>

NOTE: Check valves should never be installed immediately adjacent to a pump discharge or change in direction. Check Valves should be installed downstream from all sources of line turbulence, including fittings and valves, at a minimum of 5x the nominal pipe diameter (preferably 10x) with straight piping to provide laminar flow.

VISIT WWW.NIBCO.COM FOR CURRENT CHEM-GUIDE AND GALVANIC POTENTIAL IN PIPING SYSTEMS INFORMATION.

Visit our website for the most current information.

Class 125 Iron Body Check Valves

Bolted bonnet • horizontal swing • renewable seat and disc*

200 PSI/13.8 bar non-shock cold working pressure to -20°F to 150°F/-29°C to 66°C*

Maximum working temperature 450°F/232°C at 125 PSI/8.6 bar

125 PSI/8.6 bar saturated steam to 353°F/178°C

CONFORMS TO MSS SP-71 TYPE 1

MATERIAL LIST

PART	SPECIFICATION
1. Body Bolt	Steel ASTM A307
2. Identification Plate	Aluminum
3. Bonnet	Cast Iron ASTM A126 Class B
4. Body Gasket	Synthetic Fibers
5. Body Nut	Steel ASTM A563
6. Side Plug	Brass ASTM B16 Alloy C36000
7. Hanger Pin	Brass ASTM B16 Alloy C36000
8. Hanger	Ductile Iron ASTM A536
9. ¹ Disc	Brass ASTM B584 Alloy C84400 or ASTM A536 Ductile Iron with Brass Face Ring
10. Seat Ring	Brass ASTM B584 Alloy C84400
11. Disc Nut	Brass ASTM B16 Alloy C36000
12. Body	Cast Iron ASTM A126 Class B
13. ¹ Disc Bolt	Brass ASTM B16 Alloy C36000
14. Disc Plate**	Cast Iron ASTM A126 Class B
15. Disc Cage**	Cast Iron ASTM A126 Class B

¹12" thru 4" have Bronze ASTM B584 Disc.

¹5" thru 12" have Iron Disc with Bronze Disc Face Rings and Disc Bolt.

**These items are not in the -B, only the -W and -Y.



F-918-B
Flanged



T-918-B
Threaded

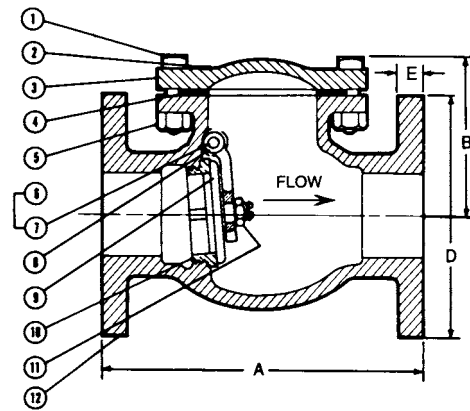

F-918-B
Flg x Flg

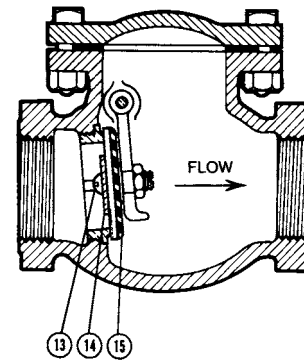

T-918
NPT x NPT
Buna-N Disc Shown

DIMENSIONS—WEIGHTS—QUANTITIES

Dimensions

Size	F-918-B		T-918-B		B	D	E	F-918-B		T-918-B					
	A	A	A	A				Lbs.	Kg.	Lbs.	Kg.				
2	50	8.00	203	6.50	165	3.94	100	6.00	152	.63	16	24	11	15	7
2½	65	8.50	216	7.50	191	4.50	114	7.00	178	.69	17	35	16	26	12
3	80	9.50	241	8.00	203	5.13	130	7.50	191	.75	19	47	21	31	14
4	100	11.50	292	9.38	238	6.13	156	9.00	229	.94	24	80	36	54	24
5	125	13.00	330	x	x	6.81	173	10.00	254	.94	24	100	45	80	36
6	150	14.00	356	x	x	8.00	203	11.00	279	1.00	25	146	66	121	54
8	200	19.50	495	x	x	9.44	240	13.50	343	1.13	29	274	124	x	x
10	250	24.50	622	x	x	12.06	306	16.00	406	1.19	30	426	193	x	x
12	300	27.50	699	x	x	16.13	410	19.00	483	1.25	32	675	306	x	x

Note: On pump discharge, the preferred check valves are:

- inline, spring assisted, center-guided, lift checks
- spring assisted twin (double) disc
- swing design with lever and weight or lever and spring

*Proper machining facilities required.

x = Not available this size.

2½" thru 12" are available with lever and weight or lever and spring.

Install 5 pipe diameters minimum downstream from pump discharge or changes in direction to avoid flow turbulence. Flow straighteners may be required in extreme cases.

NIBCO Iron Body Check Valves may be installed in both horizontal and vertical lines with upward flow or in any intermediate position.

Warning – Do Not Use For Reciprocating Air Compressor Service.

Visit our website for the most current information.

VISIT WWW.NIBCO.COM FOR CURRENT CHEM-GUIDE AND GALVANIC POTENTIAL IN PIPING SYSTEMS INFORMATION.

◆ For detailed Operating Pressure, refer to Pressure Temperature Chart on page 114.

Class 125 Iron Body Check Valves

Bolted bonnet • horizontal swing • renewable iron seat and disc*

200 PSI/13.8 bar non-shock cold working pressure to -20°F to 150°F/-29°C to 66°C†

Maximum working temperature 450°F/232°C at 125 PSI/8.6 bar

125 PSI/8.6 bar saturated steam to 353°F/178°C

CONFORMS TO MSS SP-71 TYPE 1

MATERIAL LIST

PART	SPECIFICATION
1. Body Bolt	Steel ASTM A307/SAE J429
2. Identification Plate	Aluminum
3. Bonnet	Cast Iron ASTM A126 Class B
4. Body Gasket	Synthetic Fibers
5. Body Nut	Steel ASTM A563
6. Side Plug	Steel ASTM A307
7. Hanger Pin	Steel ASTM A 108 1214L
8. Hanger	Ductile Iron ASTM A536
9. Disc	Cast Iron ASTM A126 Class B or ASTM A536 Ductile Iron (2"-4")
10. Seat Ring	Cast Iron ASTM A126 Class B
11. Disc Nut	Steel ASTM A563
12. Body	Cast Iron ASTM A126 Class B
13.† Disc Bolt	Mild Steel (not shown)

† 5" thru 12" only.



F-918-N
Flanged

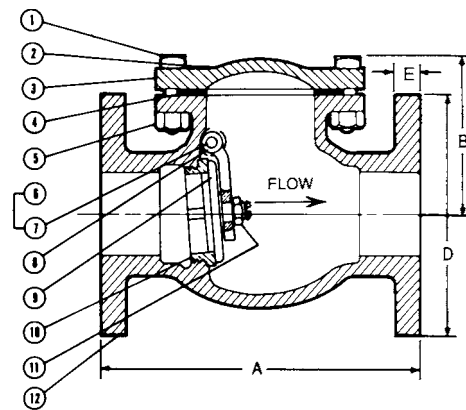

F-918-N
Flg x Flg

DIMENSIONS—WEIGHTS—QUANTITIES

Size	Dimensions								Weight		
	A		B		D		E		Lbs.	Kg.	
In.	mm.	In.	mm.	In.	mm.	In.	mm.	In.	mm.		
2	50	8.00	203	3.94	100	6.00	152	.63	16	24	11
2½	65	8.50	216	4.50	114	7.00	178	.69	17	35	16
3	80	9.50	241	5.13	130	7.50	191	.75	19	47	21
4	100	11.50	292	6.13	156	9.00	229	.94	24	80	36
5	125	13.00	330	6.81	173	10.00	254	.94	24	99	45
6	150	14.00	356	8.00	203	11.00	279	1.00	25	147	67
8	200	19.50	495	9.44	240	13.50	343	1.13	29	254	115
10	250	24.50	622	12.06	306	16.00	406	1.19	30	424	192
12	300	27.50	699	16.13	410	19.00	483	1.25	32	646	293

*Proper machining facilities required.

Note: On pump discharge, the preferred check valves are:

- inline, spring assisted, center-guided, lift checks
- spring assisted twin (double) disc
- swing design with lever and weight or lever and spring

Install 5 pipe diameters minimum downstream from pump discharge or changes in direction to avoid flow turbulence. Flow straighteners may be required in extreme cases.

NIBCO Iron Body Check Valves may be installed in both horizontal and vertical lines with upward flow or in any intermediate position.

WARNING: Do not use for Reciprocating Air Compressor Service.

VISIT WWW.NIBCO.COM FOR CURRENT CHEM-GUIDE AND GALVANIC POTENTIAL IN PIPING SYSTEMS INFORMATION.

Visit our website for the most current information.

◆ For detailed Operating Pressure, refer to Pressure Temperature Chart on page 114.

Class 250 Iron Body Check Valves

Bolted bonnet • horizontal swing • renewable bronze seat and disc*

500 PSI/34.5 bar non-shock cold working pressure to -20°F to 150°F/-29°C to 66°C*

Maximum working temperature 450°F/232°C at 250 PSI/17.2 bar

250 PSI/17.2 bar saturated steam to 406°F/208°C

CONFORMS TO MSS SP-71 TYPE 1 • APPROVED BY
THE NEW YORK CITY B.S.A. 143-69-SA AT 350 PSI
NON-SHOCK COLD WATER

MATERIAL LIST

PART	SPECIFICATION
1. Body Bolt	Steel ASTM A307/SAE J429
2. Identification Plate	Aluminum
3. Bonnet	Cast Iron ASTM A126 Class B
4. Body Gasket	Reinforced Graphite
5. Body Nut	Steel ASTM A563
6. Side Plug	Brass ASTM B16 Alloy C36000
7. Hanger Pin	Brass ASTM B16 Alloy C36000
8. Hanger	Brass ASTM B584 Alloy C84400
9. Disc Nut	Brass ASTM B584 Alloy C84400
10. Disc	Brass ASTM B584 Alloy C84400
11. Seat Ring	Brass ASTM B584 Alloy C84400
12. Body	Cast Iron ASTM A126 Class B



F-968-B
Flanged

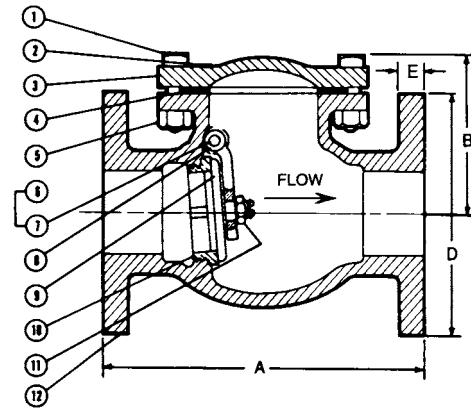

F-968-B
Flg x Flg

DIMENSIONS—WEIGHTS—QUANTITIES

Size	Dimensions								Weight	
	A		B		D		E		Lbs.	Kg.
In. mm.	In.	mm.	In.	mm.	In.	mm.	In.	mm.		
2½ 65	11.50	292	5.83	149	7.50	191	1.00	25	62	28
3 80	12.50	318	6.31	160	8.25	210	1.13	29	77	35
4 100	14.00	356	7.56	192	10.00	254	1.25	32	129	58
6 150	17.50	445	8.50	216	12.50	318	1.44	37	225	102

*Proper machining facilities required.

Note: On pump discharge, the preferred check valves are:

- inline, spring assisted, center-guided, lift checks
- spring assisted twin (double) disc
- swing design with lever and weight or lever and spring

Install 5 pipe diameters minimum downstream from pump discharge or changes in direction to avoid flow turbulence. Flow straighteners may be required in extreme cases.

NIBCO Iron Body Check Valves may be installed in both horizontal and vertical lines with upward flow or in any intermediate position.

Warning – Do Not Use For Reciprocating Air Compressor Service.

Lead-Free* Class 125/250 Iron Body Silent Check Valves

Wafer style • renewable seat and disc • spring actuated (1/2 PSI cracking pressure)

Class 125, 200 PSI/13.8 bar non-shock cold working pressure

Class 250, 400 PSI/27.6 bar non-shock cold working pressure

Maximum temperature to 200°F/93°C

W910-B-LF — 2" thru 10" ONLY

CERTIFIED LEAD-FREE* BY WQA TO NSF/ANSI 61 & 372
CONFORMS TO MSS SP-125 • FM APPROVED



C USA
COMPONENT LEAD-FREE

MATERIAL LIST

PART	SPECIFICATION
1. Body	Cast Iron ASTM 126 Class B
2. Seat	Bronze ASTM B584 Alloy C87600 (B)
2a. Seat	Buna-N Bonded to Bronze (W)
3. Disc	Bronze ASTM B584 Alloy C87600
4. Spring	Stainless Steel ASTM A313 UNS S31600
5. Bushing	Aluminum Bronze B505 C95400

DIMENSIONS—WEIGHTS—QUANTITIES

Size	Dimensions				W-910	W-960
	A		B			
In. mm.	In. mm.	In. mm.	In. mm.	Lbs. Kg.	Lbs. Kg.	
*2 50	4.25 108	2.63 67	6 5	6 3	3	
*2½ 65	5.00 127	2.88 73	7 3	7 3	3	
*3 80	5.75 146	3.13 79	12 5	12 5	5	
*4 100	7.00 178	4.00 102	18 8	18 8	8	
*5 125	8.38 213	4.63 117	27 12	27 12	12	
*6 150	9.75 248	5.50 140	42 19	42 19	19	
8 200	13.38 340	6.50 165	†85 39	86 39	39	
10 250	16.00 406	8.25 210	†146 66	†137 62	62	

*NOTE: Sizes 2" thru 6" have dual class ratings (125 lb. and 250 lb.) resulting in W-910 and W-960 being identical. 8" and 10" have special machining in accordance with Flange Class.

†Class 125 only.

*Class 250 only.

USE THIS VALVE ONLY WITH FLAT FACE FLANGE AND FULL FACE GASKET

WARNING: 1. Seat end of valve must be mated to a standard flat faced metal flange. Rubber flanges not acceptable.

2. These are not to be used as steam valves.

3. Valves are not to be used near a reciprocating air compressor.

Note: On pump discharge, the preferred check valves are:

- inline, spring assisted, center-guided, lift checks
- spring assisted twin (double) disc
- swing design with lever and weight or lever and spring

Install 5 pipe diameters minimum downstream from pump discharge or changes in direction to avoid flow turbulence. Flow straighteners may be required in extreme cases.

W-910-LF 125 lb. Class
W-960-LF 250 lb. Class

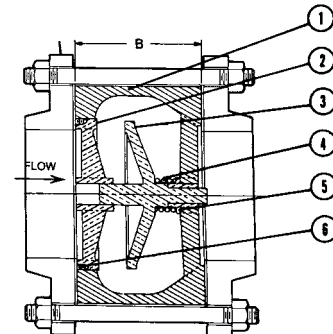

W-910-B-LF/W-960-B-LF
Wafer

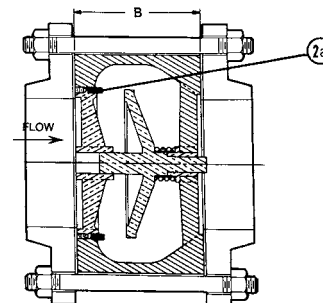

W-910-W-LF/W-960-W-LF
Wafer

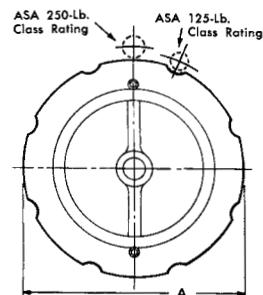

W-910-B-LF/W-960-B-LF
Wafer

*Weighted average lead content ≤ 0.25%

VISIT WWW.NIBCO.COM FOR CURRENT CHEM-GUIDE AND GALVANIC POTENTIAL IN PIPING SYSTEMS INFORMATION.

Visit our website for the most current information.

Lead-Free* Class 125/250 Iron Body Silent Check Valves

Flanged • globe style • renewable seat and disc • spring actuated (1/2 cracking pressure)

¹Class 125, 200 PSI/13.8 bar non-shock cold working pressure

²Class 250, 400 PSI/27.6 bar non-shock cold working pressure

Maximum temperature to 200°F/93°C

CERTIFIED LEAD-FREE* BY WQA TO NSF/ANSI 61 & 372 •
CONFORMS TO MSS SP-125 • CONFORMS TO MIL-V-18436F •
FM APPROVED — 2½" thru 10" ONLY (F-910-B-LF)



C USA
COMPONENT LEAD-FREE



F-910-LF, 125 lb. Class
F-960-LF, 250 lb. Class
Flanged

MATERIAL LIST

PART	SPECIFICATION
1. Body	Cast Iron ASTM 126 Class B
2. Seat	Bronze ASTM B584 Alloy C87600 (B)
2a. Seat	Buna-N Bonded to Bronze (W)
3. Disc	2½" - 10" - Bronze ASTM B584 Alloy C87600 12" - 36" - Class 250 Alloy ASTM B148 C95500
4. Spring	Stainless Steel ASTM A313 UNS S31600
5. Bushing	Aluminum Bronze B505 C95400
6. Set Screws	Stainless Steel Type 316 ASTM F879

DIMENSIONS—WEIGHTS—QUANTITIES

Size	Dimensions		F-910		F-960	
	In.	mm.	Lbs.	Kg.	Lbs.	Kg.
2½	65	5.50	140	24	11	30
3	80	6.00	152	29	13	36
4	100	7.25	184	42	19	59
5	125	8.50	216	52	24	78
6	150	9.75	248	73	33	103
8	200	12.50	318	126	57	179
10	250	15.50	394	205	93	253
12	300	14.25	362	306	139	401
14	350	15.75	400	350	172	511
16	400	17.63	448	501	227	697
18	450	18.75	476	724	328	959
20	500	20.63	524	890	404	1180
24	600	24.00	610	1220	553	1680
30	750	29.25	743	2000	907	2375
36	900	45.00	1143	4421	2005	5511

¹14" - 36" sizes - Class 125, 150 psi/10.3 bar CWP

²14" - 36" sizes - Class 250, 300 psi/20.7 bar CWP

NOTE: F-910 made to 125 lb. Flange dimensions.
F-960 made to 250 lb. Flange dimensions.

A Wafer Style Butterfly Valve can be mated on the down stream side of the F-910 2½"-10" sizes without use of spacers or adapters. 316 Stainless Steel Trim available - Consult Factory.

USE THIS VALVE ONLY WITH FLAT FACE FLANGE AND FULL FACE GASKET.

WARNING: 1. Seat end of valve must be mated to a standard flat faced metal flange. Rubber flanges not acceptable.

2. These are not to be used as steam valves.

3. Valves are not to be used near a reciprocating air compressor.

Note: On pump discharge, the preferred check valves are:

- inline, spring assisted, center-guided, lift checks
- spring assisted twin (double) disc
- swing design with lever and weight or lever and spring

Install 5 pipe diameters minimum downstream from pump discharge or changes in direction to avoid flow turbulence. Flow straighteners may be required in extreme cases.

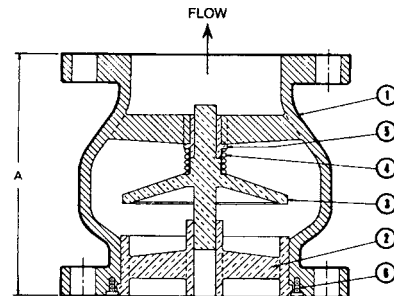

F-910-B-LF or F-960-B-LF
Flg x Flg Flg x Flg

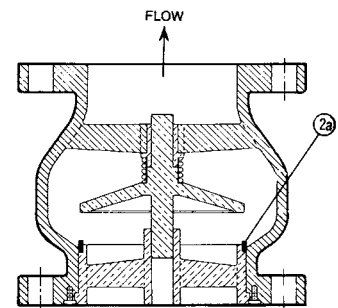

F-910-W-LF or F-960-W-LF
Flg x Flg Flg x Flg

*Weighted average lead content ≤ 0.25%

VISIT WWW.NIBCO.COM FOR CURRENT CHEM-GUIDE AND GALVANIC POTENTIAL IN PIPING SYSTEMS INFORMATION.

Visit our website for the most current information.

Lead-Free* Class 125 Iron Body Check Valves

Twin disc • wafer style • bronze disc • rubber seat • spring actuated

250 PSI/17.2 bar non-shock cold working pressure
Maximum temperature to 180°F/82°C

CERTIFIED LEAD-FREE* BY WQA TO NSF/ANSI 61 & 372 •
CONFORMS TO AWWA C518



C USA
COMPONENT LEAD-FREE



W-920-W-LF
Wafer

MATERIAL LIST

PART	SPECIFICATION
1. Body	Ductile Iron ASTM A536 Grade 65-45-12 w/Buna-N (Nitrile) resilient seat molded to body
2. Disc	Bronze ASTM B584 UNS C87600
3. Torsion Spring	Stainless Steel ASTM A313 UNS S31600
4. Disc Thrust Bearing	Stainless Steel ASTM A240 UNS S31600
5. Stabilization Sphere	Buna-N
6. Hinge Pin Retainer	Steel
7. Stop Pin Retainer	Steel
8. Disc Hinge Pin	Stainless Steel ASTM A276 UNS S31600
9. Spacer	Stainless Steel ASTM A276 UNS S31600
10. Disc Stop Pin	Stainless Steel ASTM A276 UNS S31600

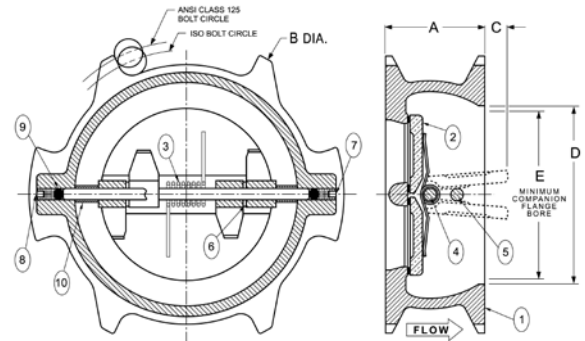

2" thru 12"

DIMENSIONS—WEIGHTS—QUANTITIES

Size	Dimensions										Weight		
	A		B		C		D		E		Lbs.	Kg.	
In.	mm.	In.	mm.	In.	mm.	In.	mm.	In.	mm.	In.	mm.		
2	50	2.13	54	5.13	130	—	—	2.88	73	—	—	4	2
2½	65	2.38	60	6.00	152	.13	3.3	3.50	89	1.31	33	5	2
3	80	2.63	67	5.63	143	.19	4.8	3.88	99	1.69	43	7	3
4	100	2.63	67	7.75	197	.63	16.0	4.75	121	3.06	78	9	4
5	125	3.25	83	7.56	192	.81	20.0	5.50	140	3.63	92	13	6
6	150	3.75	95	8.63	222	.81	32.0	6.25	171	4.25	146	19	9
8	200	5.00	127	12.25	279	1.00	33.0	8.00	222	5.50	197	37	17
10	250	5.50	140	14.75	340	2.06	64.0	10.25	276	8.50	248	65	30
12	300	7.13	181	17.38	410	1.94	60.0	12.00	327	9.25	279	94	43

NOTE: Twin Disc Check Valves can be installed horizontally or in the vertical position with flow up.

CAUTION: For horizontal flow applications, the valve must be installed with disc hinge pin in the vertical position, to insure proper operation.

WARNING: 1. Seat end of valve must be mated to a standard flat faced metal flange. Rubber flanges not acceptable.

2. These are not to be used as steam valves.

3. Valves are not to be used near a reciprocating air compressor.

Note: On pump discharge, the preferred check valves are:

- inline, spring assisted, center-guided, lift checks
- spring assisted twin (double) disc
- swing design with lever and weight or lever and spring

Install 5 pipe diameters minimum downstream from pump discharge or changes in direction to avoid flow turbulence. Flow straighteners may be required in extreme cases.

*Weighted average lead content ≤ 0.25%

VISIT WWW.NIBCO.COM FOR CURRENT CHEM-GUIDE AND GALVANIC POTENTIAL IN PIPING SYSTEMS INFORMATION.

Visit our website for the most current information.

Lead-Free* Class 125 Iron Body Check Valves

Twin disc • wafer style • bronze disc • rubber seat • spring actuated

150 PSI/10.3 bar non-shock cold working pressure
Maximum temperature to 180°F/82°C

CERTIFIED LEAD-FREE* BY WQA TO NSF/ANSI 61 & 372 •
CONFORMS TO AWWA C518



W-920-W-LF
Wafer

MATERIAL LIST — 14" thru 24"

PART	SPECIFICATION
1. Body	Cast Iron ASTM A126 Class B w/Buna-N (Nitrile) resilient seat molded to body
2. Disc	Aluminum Bronze ASTM B148 C95200
3. Torsion Spring	Stainless Steel ASTM A313 UNS S31600 or UNS S17400
4. Disc Thrust Bearing	Stainless Steel ASTM A240 UNS S31600
5. Stabilization Sphere	Buna-N
6. Hinge Pin Retainer	Steel
7. Stop Pin Retainer	Steel
8. Disc Stop Pin	Stainless Steel ASTM A276 UNS S31600
9. Disc Hing Pin	Stainless Steel ASTM A276 UNS S31600

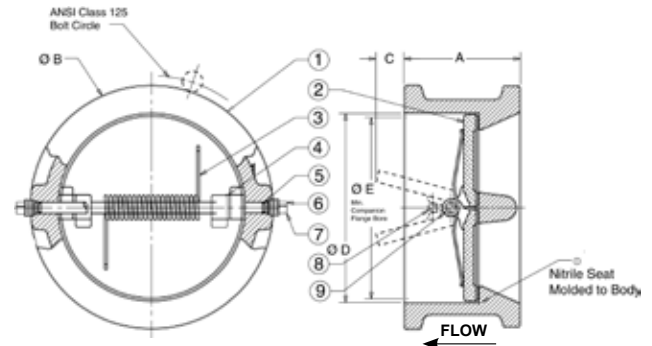

DIMENSIONS—WEIGHTS—QUANTITIES

Size	Dimensions										Weight		
	A		B		C		D		E		Lbs.	Kg.	
In.	mm.	In.	mm.	In.	mm.	In.	mm.	In.	mm.	In.	mm.		
14	350	7.25	184	17.75	451	3.25	83	14.38	365	12.50	318	187	85
16	400	7.50	191	20.25	514	4.50	114	16.38	416	15.00	381	270	122
18	450	8.00	203	21.63	549	5.38	137	18.38	467	17.00	432	350	150
20	500	8.38	213	23.88	606	6.38	162	20.25	514	19.00	483	424	192
24	600	8.75	222	28.25	718	8.50	216	24.25	616	23.00	584	589	267

NOTE: Twin Disc Check Valves can be installed horizontally or in the vertical position with flow up.

CAUTION:

For horizontal flow applications, the valve must be installed with disc hinge pin in the vertical position, to insure proper operation.

WARNING:

1. Seat end of valve must be mated to a standard flat faced metal flange. Rubber flanges not acceptable.
2. These are not to be used as steam valves.
3. Valves are not to be used near a reciprocating air compressor.
4. Install 5 pipe diameters minimum downstream from pump discharge or elbows to avoid flow turbulence. Flow straighteners may be required in extreme cases.

Note: On pump discharge, the preferred check valves are:

- inline, spring assisted, center-guided, lift checks
- spring assisted twin (double) disc
- swing design with lever and weight or lever and spring

Install 5 pipe diameters minimum downstream from pump discharge or changes in direction to avoid flow turbulence. Flow straighteners may be required in extreme cases.

*Weighted average lead content ≤ 0.25%

VISIT WWW.NIBCO.COM FOR CURRENT CHEM-GUIDE AND GALVANIC POTENTIAL IN PIPING SYSTEMS INFORMATION.

Visit our website for the most current information.

Class 125 Iron Body Check Valves

Twin disc • wafer style • bronze disc • rubber seat •
spring actuated • non slam • silent check

150 PSI/10.3 bar non-shock cold working pressure
Maximum temperature to 180°F/82°C

CONFORMS TO AWWA C518



W-920-W-LF
Wafer



C USA
COMPONENT LEAD-FREE

MATERIAL LIST — 30"

PART	SPECIFICATION
1. Body	Cast Iron ASTM A126 Class B w/Buna-N (Nitrile) resilient seat molded to body
2. Disc	Bronze ASTM A536 B584 UNS C87600
3. Torsion Spring	Stainless Steel ASTM A 313 UNS S31600 or UNS S17400
4. Disc Thrust Bearing	Stainless Steel ASTM A 240 UNS S31600
5. Stabilization Sphere	Nitrile ASTM D 2000
6. Hinge Pin Retainer	Steel
7. Stop Pin Retainer	Steel
8. Disc Stop Pin	Stainless Steel ASTM A 276 UNS S31600
9. Disc Hing Pin	Stainless Steel ASTM A 276 UNS S31600

MATERIAL LIST — 36"

PART	SPECIFICATION
1. Body	Cast Iron ASTM A126 Class B
2. Disc	Nickel Plated D.I. ASTM A536 Grade 65-45-12
3. Torsion Spring	Stainless Steel ASTM A 313 UNS S31600 or UNS S17400
4. Inner Thrust Bearing	Stainless Steel ASTM A 240 UNS S31600
5. Outer Thrust Bearing	Stainless Steel ASTM A 240 UNS S31600
6. Hinge Pin Retainer	Steel
7. Stop Pin Retainer	Steel
8. O-Ring	Nitrile ASTM D 2000
9. Shaft Collar	Stainless Steel ASTM A 240 UNS S31600
10. Stabilization Sphere	Nitrile ASTM D 2000
11. Stop Pin	Stainless Steel ASTM A 276 UNS S31600
12. Hinge Pin	Stainless Steel ASTM A 276 UNS S31600

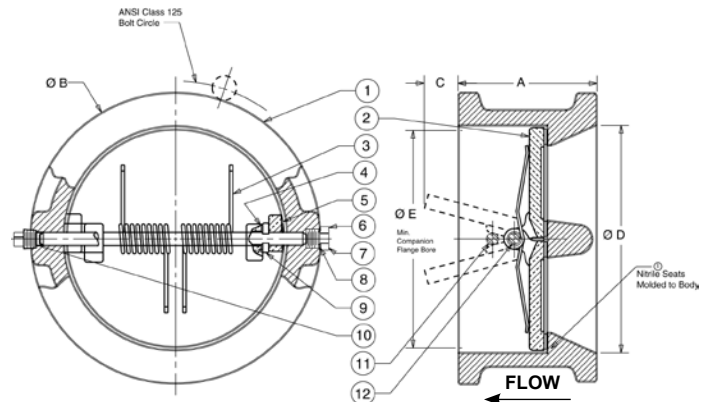
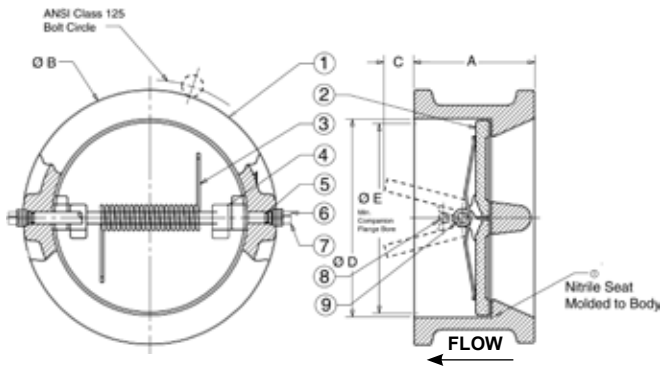

DIMENSIONS—WEIGHTS—QUANTITIES

Size	Dimensions										Weight		
	A		B		C		D		E		Lbs.	Kg.	
In.	mm.	In.	mm.	In.	mm.	In.	mm.	In.	mm.	In.	mm.		
30	750	12.00	305	34.75	883	9.50	241	30.00	762	28.50	724	1112	504
36	900	14.50	368	41.25	1048	12.00	305	36.00	914	34.50	876	1864	846

NOTE: Twin Disc Check Valves can be installed horizontally or in the vertical position with flow up.

Install 5 pipe diameters minimum downstream from pump discharge or changes in direction to avoid flow turbulence. Flow straighteners may be required in extreme cases.

CAUTION:

For horizontal flow applications, the valve must be installed with disc hinge pin in the vertical position, to insure proper operation.

WARNING:

1. Seat end of valve must be mated to a standard flat faced metal flange. Rubber flanges not acceptable.
2. These are not to be used as steam valves.
3. Valves are not to be used near a reciprocating air compressor.

Note: On pump discharge, the preferred check valves are:
- inline, spring assisted, center-guided, lift checks
- spring assisted twin (double) disc
- swing design with lever and weight or lever and spring

*Weighted average lead content ≤ 0.25%

VISIT WWW.NIBCO.COM FOR CURRENT CHEM-GUIDE AND GALVANIC POTENTIAL IN PIPING SYSTEMS INFORMATION.

Visit our website for the most current information.

Lead-Free* 250 PSI CWP Iron Body Grooved Silent Check Valves

Twin disc • grooved style • bronze disc • Buna-N seat • spring actuated

250 PSI/17.2 bar non-shock cold working pressure
Maximum temperature to 180°F/82°C at 220 PSI/15 bar

CERTIFIED LEAD-FREE* BY WQA TO NSF/ANSI 61 & 372
CONFORMS TO ANSI/AWWA C606 FOR STEEL IPS PIPE



G-920-W-LF
Grooved

MATERIAL LIST

PART	SPECIFICATION
1. Body	Ductile Iron ASTM A536 Grade 65-45-12 w/Buna-N (Nitrile) resilient seat molded to body
2. Disc	Bronze ASTM B584 Alloy C87600
3. Torsion Spring	Stainless Steel ASTM A313 UNS S31600
4. Disc Hinge Pin	Stainless Steel ASTM A276 UNS S31600
5. Disc Stop Pin	Stainless Steel ASTM A276 UNS S31600
6. Disc Thrust Bearing	Stainless Steel ASTM A240 UNS S31600
7. Hinge Pin Retainer	Steel
8. Stop Pin Retainer	Steel
9. Stabilization Sphere	Buna-N
10. Spacer	Stainless Steel ASTM A276 UNS S31600

Sizes 10" and 12" furnished with lifting eyebolt

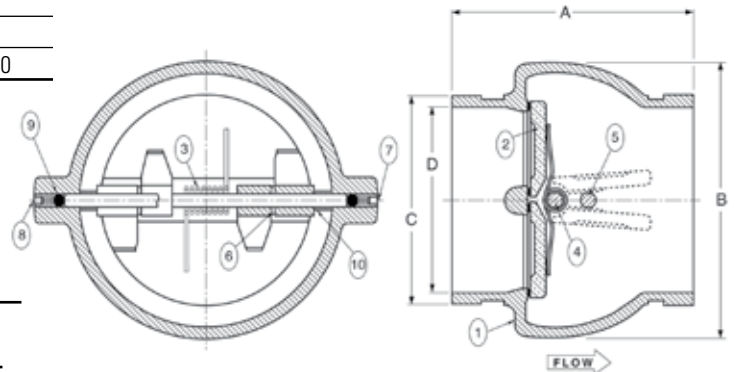

DIMENSIONS—WEIGHTS—QUANTITIES

Size	Dimensions								Weight	
	A		B		C		D		Lbs.	Kg.
In. mm.	In. mm.	In. mm.	In. mm.	In. mm.	In. mm.	In. mm.	In. mm.	Lbs.	Kg.	
2 50	4.66 111	4.13 105	2.38 60	2.00 51	3.30 84	1.49 35				
2½ 65	4.91 125	4.88 124	2.88 73	2.41 61	4.50 114	2.04 46				
3 80	5.31 135	5.38 137	3.50 89	2.94 75	7.30 185	3.31 74				
4 100	5.38 137	6.00 152	4.50 114	3.91 99	8.60 217	3.90 87				
5 125	5.72 145	7.06 179	5.56 141	4.89 124	13.00 293	5.90 132				
6 150	6.00 152	8.13 206	6.63 168	5.92 150	18.00 402	8.17 184				
8 200	6.72 171	10.03 255	8.63 219	7.91 201	30.00 669	13.6 305				
10 250	7.78 198	12.38 314	10.75 273	10.00 254	56.00 1245	25.4 571				
12 300	8.19 208	14.38 365	12.75 324	11.94 303	81.80 1827	36.7 827				

Groove dimensions conform to ANSI/AWWA specification C606 Table 4 (Cut Groove Dimensions)

NOTE: Twin Disc Check Valves can be installed horizontally or in the vertical position with flow up.

CAUTION: For horizontal flow applications, the valve must be installed with disc hinge pin in the vertical position to insure proper operation.

WARNING:

1. This valve is not to be used as a steam valve.
2. Valves are not to be used near a reciprocating air compressor.
3. Install 5 pipe diameters minimum downstream from pump discharge or elbows to avoid flow turbulence. Flow straighteners may be required in extreme cases.

Note: On pump discharge, the preferred check valves are:
- inline, spring assisted, center-guided, lift checks
- spring assisted twin (double) disc
- swing design with lever and weight or lever and spring

Install 5 pipe diameters minimum downstream from pump discharge or changes in direction to avoid flow turbulence. Flow straighteners may be required in extreme cases.

*Weighted average lead content ≤ 0.25%

VISIT WWW.NIBCO.COM FOR CURRENT CHEM-GUIDE AND GALVANIC POTENTIAL IN PIPING SYSTEMS INFORMATION.

Visit our website for the most current information.

Class 250 Iron Y-Strainers

Screw-in cap • blow-off plug • threaded ends • 20 mesh stainless steel screen or stainless steel perforated screen

250 PSI/17.2 bar saturated steam to 406°F/207°C
400 PSI/27.5 bar non-shock cold working pressure

CONFORMS TO ANSI B1.20.1 (NPT)

MATERIAL LIST

PART	SPECIFICATION
1. Body	Cast Iron ASTM A126 Class B
2. Cap	Cast Iron ASTM A126 Class B
3. Screen	Stainless Steel AISI 304
4. Gasket	Metal-Filled Graphite
5. Plug	Cast Iron ASTM A126 Class B



T-751-A
Threaded

DIMENSIONS—WEIGHTS—QUANTITIES

Size	Dimensions								Weight Lbs. Kg.		
	A		B		C		D				
In.	mm.	In.	mm.	In.	mm.	In.	mm.	In.	mm.		
1/4	8	3.19	81.0	2.1	52.4	1/4	8	1.63	41.4	1.39	0.63
3/8	10	3.19	81.0	2.1	52.4	1/4	8	1.63	41.4	1.39	0.63
1/2	15	3.19	81.0	2.1	52.4	1/4	8	1.63	41.4	1.39	0.63
3/4	20	3.75	95.3	2.4	61.9	3/8	10	1.77	45.0	2.20	0.99
1	25	4.00	101.6	2.3	58.7	3/8	10	2.19	55.6	3.08	1.39
1¼	32	5.00	127.0	3.4	85.8	3/4	20	2.52	64.0	5.06	2.29
1½	40	5.75	146.1	3.9	98.4	3/4	20	2.99	75.9	7.70	3.49
2	50	7.00	177.8	4.8	120.7	1	25	3.54	89.9	12.54	5.68
2½	65	9.25	235.0	5.9	149.2	1½	40	4.25	108.0	24.42	11.08
3	80	10	254.0	6.0	152.4	1½	40	5.00	127.0	29.26	13.27

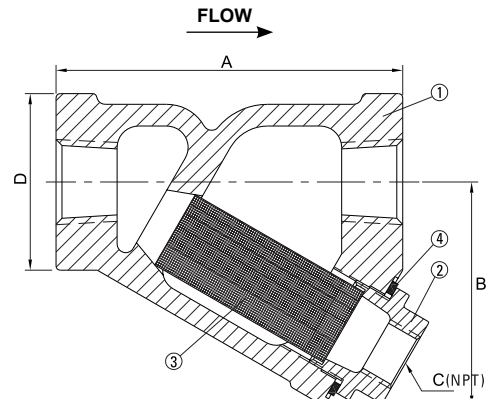

T-751-A
Threaded

FLOW COEFFICIENTS			
SIZE	C _v	SIZE	C _v
1/4"	9.2	1¼"	44
3/8"	9.2	1½"	61
1/2"	9.2	2"	97
3/4"	19	2½"	130
1"	29	3"	160

NOTE: strainer drain plugs are installed hand tight only allowing easy removal for installation of manual drain valve. If manual drain valves are not used, installer must tighten drain plug for proper seal.

Class 125 Iron Y-Strainer

Bolted bonnet • blow-off plug • flanged end • 20 mesh stainless steel screen or stainless steel perforated screen

2" - 12": 125 PSI/8.6 bar saturated steam to 353°F/178°C
200 PSI/13.8 bar non-shock cold working pressure

14" & 16": 100 PSI/6.9 bar saturated steam to 353°F/178°C
150 PSI/ 10.3 bar non-shock cold working pressure

CONFORMS TO ANSI B16.1 (FLANGE)

MATERIAL LIST

PART	SPECIFICATION
1. Body	Cast Iron ASTM A126 Class B
2. Bonnet	Cast Iron ASTM A126 Class B
3. Screen	Stainless Steel AISI 304
4. Bolt	Carbon Steel ASTM A307
5. Gasket	Metal-Filled Graphite
6. Plug	Cast Iron ASTM A126 Class B

DIMENSIONS—WEIGHTS

SIZE	Dimensions										Weight	
	A		B		C		D		E		Lbs.	Kg.
In. mm.	In. mm.	In. mm.	In. mm.	In. mm.	In. mm.	In. mm.	In. mm.	In. mm.	In. mm.			
2	50 7.87	199.9	5.25 133.4	1/2 15	6.0 152.4	2.00 50.8	18.00 457.2	2.00 50.8	18.00 457.2	18.00	8.16	
2½	65 10.00	254.0	6.50 165.1	1 25	7.0 177.8	2.50 63.5	28.00 711.2	2.50 63.5	28.00 711.2	28.00	12.70	
3	80 10.12	257.0	7.00 177.8	1 25	7.5 190.5	3.00 76.2	34.00 863.6	3.00 76.2	34.00 863.6	34.00	15.42	
4	100 12.12	307.8	8.25 209.6	1½ 40	9.0 228.6	4.00 101.6	60.00 1524.0	4.00 101.6	60.00 1524.0	60.00	27.22	
5	125 15.62	396.7	11.25 285.8	2 50	10.0 254.0	5.00 127.0	95.00 2413.0	5.00 127.0	95.00 2413.0	95.00	43.09	
6	150 18.50	469.9	13.50 342.9	2 50	11.0 279.4	6.00 152.4	133.00 3378.0	6.00 152.4	133.00 3378.0	133.00	60.33	
8	200 21.62	549.1	15.50 393.7	2 50	13.5 342.9	8.00 203.2	247.00 6248.0	8.00 203.2	247.00 6248.0	247.00	112.04	
10	250 26.00	660.4	18.50 469.9	2 50	16.0 406.4	10.00 254.0	320.00 8128.0	10.00 254.0	320.00 8128.0	320.00	145.15	
12	300 29.87	758.7	21.75 552.5	2 50	19.0 482.6	12.00 304.8	579.00 14698.0	12.00 304.8	579.00 14698.0	579.00	262.63	
14*	350 33.25	844.6	26.06 662.0	2 50	21.0 533.4	14.00 355.6	772.00 19608.0	14.00 355.6	772.00 19608.0	772.00	350.17	
16*	400 38.75	984.3	30.15 765.8	2 50	23.5 596.9	16.00 406.4	1133.00 28808.0	16.00 406.4	1133.00 28808.0	1133.00	513.92	

*Sizes 14" and 16" rated to 150 CWP, 100 SWP

FLOW COEFFICIENTS

SIZE	C _v	SIZE	C _v
2"	68	8"	925
2½"	125	10"	1692
3"	162	12"	2260
4"	273	14"	3200
5"	382	16"	4950
6"	557		

NOTE: 2" - 12": 125 psi saturated steam to 353°F/178°C and 200 psi CWP
14" and 16": 100 psi saturated steam to 85°F/150 psi CWP



F-721-A
Flanged

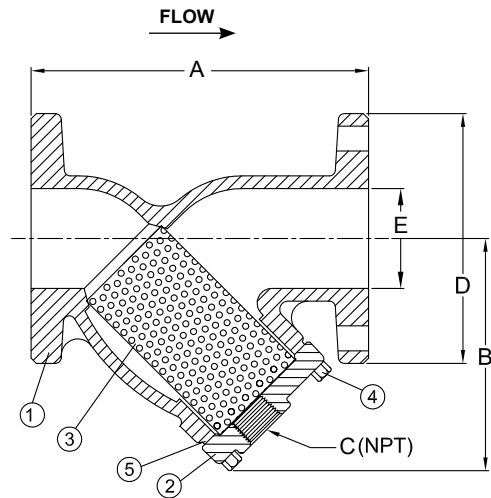

F-721-A
Flanged

NOTE: strainer drain plugs are installed hand tight only allowing easy removal for installation of manual drain valve. If manual drain valves are not used, installer must tighten drain plug for proper seal.









SCREEN SIZE:

2" - 4": 1/16" perforation (37% open area)

5" - 16": 1/8" perforation (40% open area)

Ductile and Alloy Iron Gate Valves

Illustrated Index

<p>3% Nickel Iron Body Gate Valve Outside Screw and Yoke Stainless Steel Trim Class 125 SWP 200 lb. CWP</p>  <p>F-617-13 Solid Wedge Sizes 2" thru 12" Flanged Ends Page 75</p>	<p>3% Nickel Iron Body Gate Valve Outside Screw and Yoke Stainless Steel Trim Class 125 SWP 150 lb. CWP</p>  <p>F-617-13 Solid Wedge Sizes 14" thru 24" Flanged Ends Page 76</p>	<p>Ductile Iron Body Gate Valve Outside Screw and Yoke Brass Trim Class 150 SWP 285 lb. CWP</p>  <p>F-637-31 Solid Wedge Sizes 2" thru 12" Flanged-Raised Face Page 77</p>	<p>Ductile Iron Body Gate Valve Outside Screw and Yoke Brass Trim Class 150 SWP 285 lb. CWP</p>  <p>F-637-31 Solid Wedge Sizes 14" thru 24" Flanged-Raised Face Page 78</p>
<p>Ductile Iron Body Gate Valve Outside Screw and Yoke 316SS Stainless Steel Trim Class 150 SWP 285 lb. CWP</p>  <p>F-637-33 Solid Wedge Sizes 2" thru 12" Flanged-Raised Face Page 79</p>	<p>Ductile Iron Body Gate Valve Outside Screw and Yoke 316SS Stainless Steel Trim Class 150 SWP 285 lb. CWP</p>  <p>F-637-33 Solid Wedge Sizes 14" thru 24" Flanged-Raised Face Page 80</p>	<p>Ductile Iron Body Gate Valve Inside Screw Brass Trim Class 150 SWP 285 lb. CWP</p>  <p>F-639-31 Non-Rising Stem • Solid Wedge Sizes 2" thru 16" Flanged-Raised Face Page 81</p>	<p>Ductile Iron Body Gate Valve Inside Screw 316SS Stainless Steel Trim Class 150 SWP 285 lb. CWP</p>  <p>F-639-33 Non-Rising Stem • Solid Wedge Sizes 2" thru 16" Flanged-Raised Face Page 82</p>

VISIT WWW.NIBCO.COM FOR CURRENT CHEM-GUIDE AND GALVANIC POTENTIAL IN PIPING SYSTEMS INFORMATION.

Visit our website for the most current information.

Class 125 3% Nickel Iron Body Gate Valves

Bolted bonnet • outside screw and yoke • solid wedge • stainless steel trim

200 PSI/13.8 bar non-shock cold working pressure to -20°F to 150°F/-29°C to 66°C

Maximum working temperature 450°F/232°C at 125 PSI/8.6 bar

125 PSI/8.6 bar saturated steam to 353°F/178°C

CONFORMS TO MSS SP-70

MATERIAL LIST

PART	SPECIFICATION
1. Stem	ASTM A 276 S31600SS
2. Handwheel Nut	Ductile Iron ASTM A536
3. Identification Plate	Aluminum
4. Yoke Bushing	Ductile Iron ASTM A536
5. Handwheel	Cast Iron ASTM A126 Class B
6. Bonnet Cap Nut	Steel ASTM A563
7. Bonnet Cap	Ductile Iron ASTM A536
8. ¹ Bonnet	ASTM A126 3% Nickel Iron Class B
9. Bonnet Cap Bolt	Steel ASTM A307/SAE J429
10. Gland Follower Nut	Steel ASTM A563
11. Gland Follower	Ductile Iron ASTM A536
12. Packing Gland	ASTM A276 S31600SS
13. Packing	PTFE Braided Synthetic Fiber
14. Gland Follower Bolt	Steel ASTM A307/SAE J429
15. Backseat Bushing	ASTM A276 S31600SS
16. Body Nut	Steel ASTM A563
17. Body Bolt	Steel ASTM A307/SAE J429
18. Wedge Pin	ASTM A276 S31600SS
19. Body	ASTM A126 3% Nickel Iron Class B
20. Seat Ring	ASTM A351 CF8M Stainless
21. Wedge Face Ring	ASTM A351 CF8M Stainless
22. ² Wedge	ASTM A126 3% Nickel Iron Class B
23. Body Gasket	Synthetic Fibers
24. Stem Collar	ASTM A276 S31600SS
25. Grease Fitting	Alemite 1743B (not shown)

¹Sizes thru 8" made with Yoke Integral with Bonnet. 10" and 12" sizes made with separate Yoke Bolted to Bonnet.

²Sizes 2" thru 3" have Solid ASTM A 351 CF8M Wedges. Sizes 4" thru 12" made with ASTM A126 3% Ni-Iron Wedge with ASTM A351 CF8M Wedge Face Rings.

DIMENSIONS—WEIGHTS—QUANTITIES

Size	Dimensions										Weight		
	A		B		C		D		E		Lbs.	Kg.	
In. mm.	In. mm.	In. mm.	In. mm.	In. mm.	In. mm.	In. mm.	In. mm.	In. mm.	In. mm.	Lbs.	Kg.		
2	50	7.00	178	16.31	414	8.00	203	6.00	152	.63	16	41	19
2½	65	7.50	191	17.19	437	8.00	203	7.00	178	.69	17	54	25
3	80	8.00	203	19.50	495	8.00	203	7.50	191	.75	19	66	30
4	100	9.00	229	24.00	610	10.00	254	9.00	229	.94	24	109	49
6	150	10.50	267	31.06	789	12.00	305	11.00	279	1.00	25	179	81
8	200	11.50	292	40.19	1021	14.00	356	13.50	343	1.13	29	309	140
10	250	13.00	330	48.25	1226	16.00	406	16.00	406	1.19	30	481	218
12	300	14.00	356	56.88	1445	18.00	457	19.00	483	1.25	32	706	320



F-617-13
Flanged

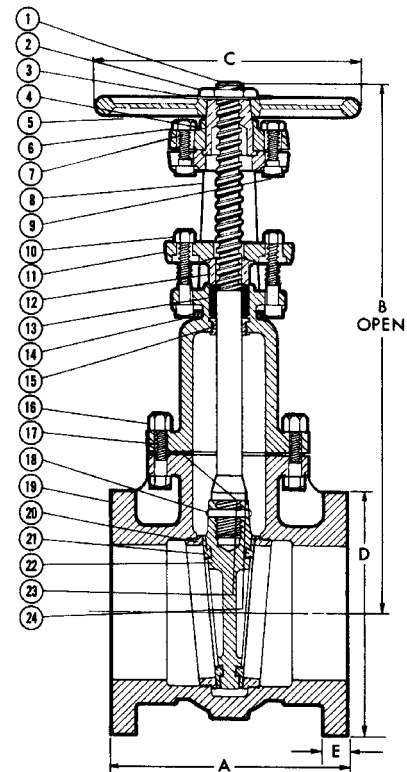

F-617-13
Flg x Flg

FREEZING WEATHER PRECAUTION: Subsequent to testing a piping system, valves should be left in an open position to allow complete drainage.

◆ For detailed Operating Pressure, refer to Pressure Temperature Chart on page 114.

VISIT WWW.NIBCO.COM FOR CURRENT CHEM-GUIDE AND GALVANIC POTENTIAL IN PIPING SYSTEMS INFORMATION.

Visit our website for the most current information.

Class 125 3% Nickel Iron Body Gate Valves

Bolted bonnet • outside screw and yoke • solid wedge • stainless steel trim

150 PSI/10.3 bar non-shock cold working pressure from -20°F to 150°F/-29°C to 66°C*

Maximum working temperature 350°F/177°C at 100 PSI/6.9 bar

***100 PSI/6.9 bar saturated steam to 338°F/170°C**

****50 PSI/3.4 bar saturated steam to 297°F/147°C**

CONFORMS TO MSS SP-70

MATERIAL LIST

PART	SPECIFICATION
1. Handwheel Nut	Ductile Iron ASTM A536
2. Identification Tag	Aluminum
3. Handwheel	Fabricated Steel
4. Yoke Bushing	Ductile Iron ASTM A536
5. Split Yoke Bolt	Steel ASTM A307/SAE J429
6. Split Yoke Bolt Nut	Steel ASTM A563
7. Yoke	ASTM A126 3% Nickel Iron Class B
8. Gland Follower Nut	Steel ASTM A307/SAE J429
9. Gland Follower	Ductile Iron ASTM A536
10. Yoke Bolt	Steel ASTM A307/SAE J429
11. Yoke Bolt Nut	Steel ASTM A563
12. Gland Follower Bolt	Steel ASTM A307/SAE J429
13. Packing Gland	ASTM A276 S31600SS
14. Packing	PTFE Braided
15. Backseat Bushing	ASTM A351 CF8M
16. Bonnet	ASTM A126 3% Nickel Iron Class B
17. Stem	ASTM A276 S31600SS
18. Bonnet Bolt	Steel ASTM A307/SAE J429
19. Bonnet Bolt Nut	Steel ASTM A563
20. Bonnet Gasket	Synthetic Fibers
21. Body	ASTM A126 3% Nickel Iron Class B
22. Wedge	ASTM A126 3% Nickel Iron Class B
23. Seat Ring	ASTM A351 CF8M
24. Wedge Ring	ASTM A351 CF8M
25. Swing Nut	Steel ASTM A563
26. Swing Bolt	Steel ASTM A307/SAE J429
27. Grease Fitting	Alemite 1743B (not shown)
28. Stem Collar	ASTM A276 S31600SS (not shown)
29. Wedge Pin	ASTM A276 S31600SS (not shown)
30. Wedge Nut	Ductile Iron ASTM A536 (not shown)



F-617-13
Flanged

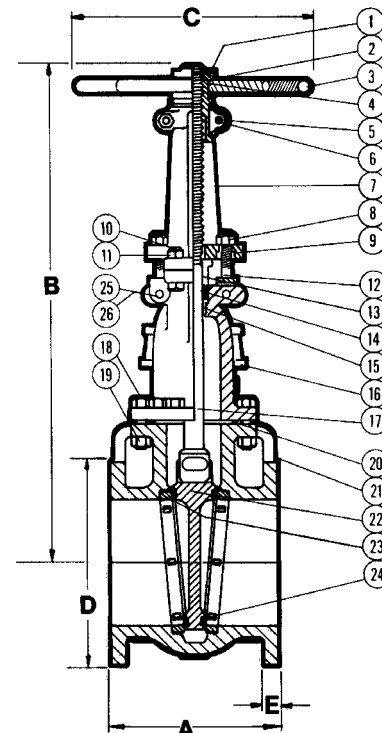

F-617-13
Flg x Flg

DIMENSIONS—WEIGHTS—QUANTITIES

Size	Dimensions										Weight		
	A		B		C		D		E		Lbs.	Kg.	
In.	mm.	In.	mm.	In.	mm.	In.	mm.	In.	mm.	In.	mm.		
14	350	15.00	381	65.50	1664	24.00	610	21.00	533	1.38	35	890	404
16	400	16.00	406	74.50	1892	24.00	610	23.50	597	1.44	37	1252	568
18	450	17.00	432	82.50	2096	24.00	610	25.00	635	1.56	40	1596	725
20	500	18.00	457	91.00	2311	30.00	762	27.50	699	1.69	43	2023	918
24	600	20.00	508	107.50	2731	30.00	762	32.00	813	1.88	48	2907	1320

*18", 20" and 24"

** 14" and 16"

FREEZING WEATHER PRECAUTION: Subsequent to testing a piping system, valves should be left in an open position to allow complete drainage.

VISIT WWW.NIBCO.COM FOR CURRENT CHEM-GUIDE AND GALVANIC POTENTIAL IN PIPING SYSTEMS INFORMATION.

Visit our website for the most current information.

◆ For detailed Operating Pressure, refer to Pressure Temperature Chart on page 114.

Class 150 Ductile Iron Body Gate Valves

Raised face flanges • bolted bonnet • outside screw and yoke • solid wedge • bronze trim

285 PSI/19.7 bar non-shock cold working pressure to -20°F to 100°F/-29°C to 38°C*

Maximum working temperature 650°F/343°C at 125 PSI/8.6 bar

150 PSI/10.3 bar saturated steam to 366°F/186°C

CONFORMS TO MSS SP-128

MATERIAL LIST

PART	SPECIFICATION
1. Stem	Brass ASTM B 371
2. Handwheel Nut	Brass ASTM B584
3. Identification Plate	Aluminum
4. Yoke Bushing	Brass ASTM B584 C84400
5. Handwheel	Iron ASTM A126 Class B
6. Bonnet Cap Nut	Steel ASTM A563
7. Bonnet Cap	Ductile Iron ASTM A536
8. ¹ Bonnet	Ductile Iron ASTM A395
9. Bonnet Cap Bolt	Steel ASTM A307/SAE J429
10. Gland Follower Nut	Steel ASTM A563
11. Gland Follower	Ductile Iron ASTM A536
12. Packing Gland	Zinc Plated Powdered Iron ASTM B783 or Brass ASTM B16 Alloy C3600
13. Packing	PTFE Braided Synthetic Fiber
14. Gland Follower Bolt	Steel ASTM A307/SAE J429
15. Backseat Bushing	Brass ASTM B584 C84400
16. Body Nut	Steel ASTM A563
17. Body Bolt	Steel ASTM A307/SAE J429
18. Wedge Pin	Brass ASTM B 371 C69430/C69400
19. Body	Ductile Iron ASTM A395
20. ³ Seat Ring	Bronze ASTM B584 C84400
21. Wedge Face Ring	Brass ASTM B584 C84400
22. ² Wedge	Ductile Iron ASTM A395
23. Body Gasket	Synthetic Fibers
24. Stem Collar	Brass ASTM B 371 C69430/C69400
25. Grease Fitting	Alemite 1743B (not shown)

¹Sizes thru 8" made with Yoke Integral with Bonnet. 10" and 12" sizes made with separate Yoke Bolted to Bonnet.

²Sizes 2" thru 6" are all Bronze (31 Trim).

Sizes 8" thru 12" Ductile Iron Wedge with Bronze Wedge Face Rings (31 Trim).

³Lugs may be removed at customer's request - POA.

DIMENSIONS—WEIGHTS—QUANTITIES

Size	Dimensions										Weight		
	A		B		C		D		E		Lbs.	Kg.	
In.	mm.	In.	mm.	In.	mm.	In.	mm.	In.	mm.	In.	mm.		
2	50	7.00	178	16.31	414	8.00	203	6.00	152	.63	16	41	19
2½	65	7.50	191	17.19	437	8.00	203	7.00	178	.69	17	55	25
3	80	8.00	203	19.50	495	8.00	203	7.50	191	.75	19	67	30
4	100	9.00	229	24.00	610	10.00	254	9.00	229	.94	24	107	48
5	125	10.00	254	27.13	689	10.00	254	10.00	254	.94	24	145	66
6	150	10.50	267	31.06	789	12.00	305	11.00	279	1.00	25	178	81
8	200	11.50	292	40.19	1021	14.00	356	13.50	343	1.13	29	309	140
10	250	13.00	330	48.25	1226	16.00	406	16.00	406	1.19	30	481	218
12	300	14.00	356	56.88	1445	18.00	457	19.00	483	1.25	32	706	320



F-637-31
Flanged-Raised Face

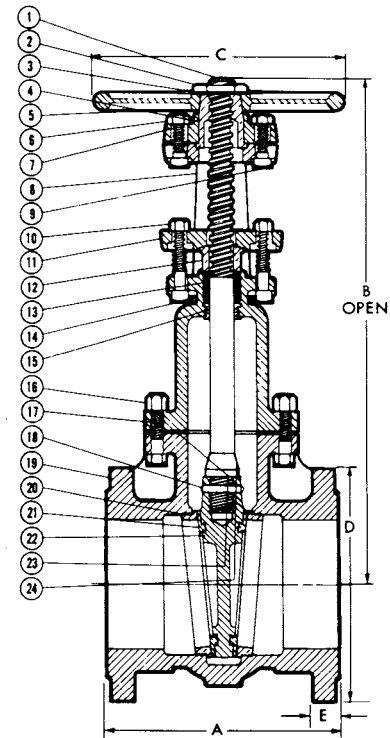

F-637-31
Flg x Flg

FREEZING WEATHER PRECAUTION: Subsequent to testing a piping system, valves should be left in an open position to allow complete drainage.

◆For detailed Operating Pressure, refer to Pressure Temperature Chart on page 114.

VISIT WWW.NIBCO.COM FOR CURRENT CHEM-GUIDE AND GALVANIC POTENTIAL IN PIPING SYSTEMS INFORMATION.

Visit our website for the most current information.

Class 150 Ductile Iron Body Gate Valves

Raised face flanges • bolted bonnet • outside screw and yoke • solid wedge • bronze trim

285 PSI/19.7 bar non-shock cold working pressure to -20°F to 100°F/-29°C to 38°C

Maximum working temperature 650°F/343°C at 125 PSI/8.6 bar

150 PSI/10.3 bar saturated steam to 366°F/186°C

CONFORMS TO MSS SP-128

MATERIAL LIST

PART	SPECIFICATION
1. Handwheel Nut	Brass ASTM B584 C84400
2. Identification Plate	Aluminum
3. Handwheel	Fabricated Steel
4. Yoke Bushing	Brass ASTM B584 C84400
5. Split Yoke Bolt	Steel ASTM A307/SAE J429
6. Split Yoke Bolt Nut	Steel ASTM A563
7. Yoke	Ductile Iron ASTM A536
8. Eye Bolt Nut	Brass ASTM F467
9. Gland Follower	Ductile Iron ASTM A536
10. Yoke Bolt	Steel ASTM A307/SAE J429
11. Yoke Bolt Nut	Steel ASTM A563
12. Gland Follower Eye Bolt	Steel ASTM A307/SAE J429
13. Packing Gland	Brass ASTM B584 C84400
14. Packing	PTFE Braided
15. Backseat Bushing	Brass ASTM B371
16. Bonnet	Ductile Iron ASTM A395
17. Stem	Brass ASTM B371
18. Bonnet Bolt	Steel ASTM A307/SAE J429
19. Bonnet Bolt Nut	Steel ASTM A563
20. Bonnet Gasket	Synthetic Fibers
21. Body	Ductile Iron ASTM A395
22. Wedge	Ductile Iron ASTM A395
23. ¹ Seat Ring	Brass ASTM B584 C84400
24. Wedge Ring	Brass ASTM B584 C84400
25. Swing Nut	Steel ASTM A563
26. Swing Bolt	Steel ASTM A307/SAE J429
27. Grease Fitting	Alemite 1743B (not shown)
28. Stem Collar	Brass ASTM B371 (not shown) C69430/C69400
29. Wedge Pin	Brass ASTM B371 (not shown) C69430/C69400
30. Wedge Nut	Brass ASTM B584 (not shown) C69430/C69400

¹Lugs may be removed at customer's request – POA.

DIMENSIONS—WEIGHTS—QUANTITIES

Size	Dimensions										Turns to Open	Weight		
	A		B		C		D		E			Lbs.	Kg.	
In.	mm.	In.	mm.	In.	mm.	In.	mm.	In.	mm.	In.	mm.			
14	350	15.00	381	65.50	1664	24.00	610	21.00	533	1.38	35	29.38	892	405
16	400	16.00	406	74.50	1892	24.00	610	23.50	597	1.44	37	33.50	1253	568
18	450	17.00	432	82.50	2096	24.00	610	25.00	635	1.56	40	37.63	1592	722
20	500	18.00	457	91.00	2311	30.00	762	27.50	699	1.69	43	41.88	2008	911
24	600	20.00	508	107.50	2731	30.00	762	32.00	813	1.88	48	50.06	2907	1318



F-637-31
Flanged-Raised Face

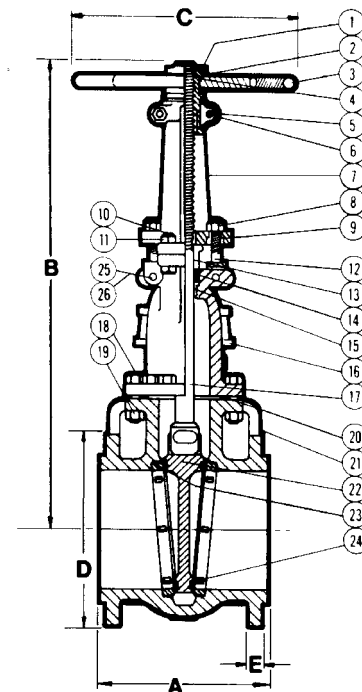

F-637-31
Flg x Flg

FREEZING WEATHER PRECAUTION: Subsequent to testing a piping system, valves should be left in an open position to allow complete drainage.

◆ For detailed Operating Pressure, refer to Pressure Temperature Chart on page 114.

VISIT WWW.NIBCO.COM FOR CURRENT CHEM-GUIDE AND GALVANIC POTENTIAL IN PIPING SYSTEMS INFORMATION.

Visit our website for the most current information.

Class 150 Ductile Iron Body Gate Valves

Raised face flanges • bolted bonnet • outside screw and yoke • solid wedge • 316 stainless steel trim

285 PSI/19.7 bar non-shock working pressure to -20°F to 100°F/-29°F to 38°C†

Maximum working temperature 650°F/343°C at 125 PSI/8.6 bar

150 PSI/10.3 bar saturated steam to 366°F/186°C

CERTIFIED LEAD-FREE* TO NSF/ANSI-61-8 (INCLUDES ANNEX F AND G) AND NSF/ANSI-372
CONFORMS TO MSS SP-128



NSF/ANSI 61
NSF/ANSI 372

MATERIAL LIST

PART	SPECIFICATION
1. Stem	Stainless Steel ASTM A 276 S31600
2. Handwheel Nut	Ductile Iron ASTM A395
3. Identification Plate	Aluminum
4. Yoke Bushing	Ductile Iron ASTM A536
5. Handwheel	Iron ASTM A126 Class B
6. Bonnet Cap Nut	Steel ASTM A563
7. Bonnet Cap	Ductile Iron ASTM A536
8. Bonnet ¹	Ductile Iron ASTM A395
9. Bonnet Cap Bolt	Steel ASTM A307/SAE J429
10. Gland Follower Nut	Steel ASTM A563
11. Gland Follower	Ductile Iron ASTM A536
12. Packing Gland	Stainless Steel ASTM A276 S31600
13. Packing	PTFE Braided Synthetic Fiber
14. Gland Follower Bolt	Steel ASTM A307/SAE J429
15. Backseat Bushing	Stainless Steel ASTM A276
16. Body Nut	Steel ASTM A563
17. Body Bolt	Steel ASTM A307/SAE J429
18. Wedge Pin	Stainless Steel ASTM A276
19. Body	Ductile Iron ASTM A 395
20. Seat Ring ²	Stainless Steel ASTM A 351 CF8M
21. Wedge Face Ring	Stainless Steel ASTM A 351 CF8M
22. Wedge ²	Ductile Iron ASTM A 395
23. Body Gasket	Synthetic Fibers
24. Stem Collar	Stainless Steel ASTM A276 S31600
25. Grease Fitting	Alemite 1743B (not shown)

¹Sizes 2" thru 8" made with Yoke Integral with Bonnet. 10" and 12" sizes made with separate Yoke Bolted to Bonnet.

²Size 2" thru 3" have solid wedges ASTM A351 CF8M.

Sizes 4" thru 12" made with ASTM A395 wedge with ASTM A351 CF8M face rings.

DIMENSIONS—WEIGHTS—QUANTITIES

Size	Dimensions										Weight		
	A		B		C		D		E				
	In.	mm.	In.	mm.	In.	mm.	In.	mm.	In.	mm.	Lbs.	Kg.	
2	50	7.00	178	16.31	414	8.00	203	6.00	152	.63	16	40	18
2½	65	7.50	191	17.19	437	8.00	203	7.00	178	.69	17	54	25
3	80	8.00	203	19.50	495	8.00	203	7.50	191	.75	19	66	30
4	100	9.00	229	24.00	610	10.00	254	9.00	229	.94	24	107	48
5	125	10.00	254	27.13	689	10.00	254	10.00	254	.94	24	144	66
6	150	10.50	267	31.06	789	12.00	305	11.00	279	1.00	25	178	81
8	200	11.50	292	40.19	1021	14.00	356	13.50	343	1.13	29	309	140
10	250	13.00	330	48.25	1226	16.00	406	16.00	406	1.19	30	479	217
12	300	14.00	356	56.88	1445	18.00	457	19.00	483	1.25	32	706	320



F-637-33
Flanged-Raised Face

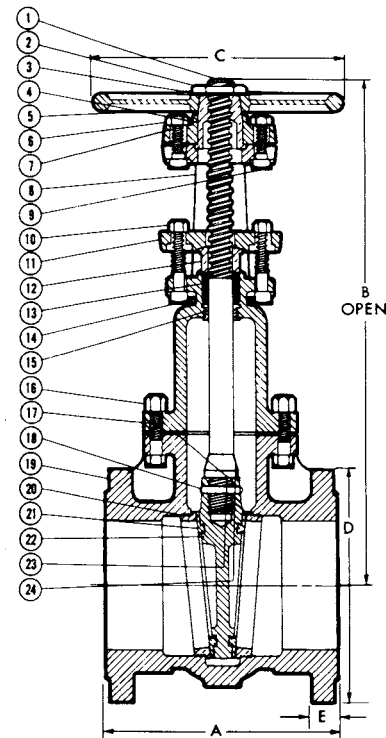

F-637-33
Flg x Flg

FREEZING WEATHER PRECAUTION: Subsequent to testing a piping system, valves should be left in an open position to allow complete drainage.

◆For detailed Operating Pressure, refer to Pressure Temperature Chart on page 114.

VISIT WWW.NIBCO.COM FOR CURRENT CHEM-GUIDE AND GALVANIC POTENTIAL IN PIPING SYSTEMS INFORMATION.

Visit our website for the most current information.

Class 150 Ductile Iron Body Gate Valves

Raised face flanges • bolted bonnet • outside screw and yoke • solid wedge • 316 stainless steel trim

285 PSI/19.7 bar non-shock cold working pressure to -20°F to 100°F/-29°C to 38°C[♦]

Maximum working temperature 650°F/343°C at 125 PSI/8.6 bar

150 PSI/10.3 bar saturated steam to 366°F/186°C

CERTIFIED LEAD-FREE* TO NSF/ANSI-61-8 (INCLUDES ANNEX F AND G) AND NSF/ANSI-372
CONFORMS TO MSS SP-128



NSF/ANSI 61
NSF/ANSI 372

MATERIAL LIST

PART	SPECIFICATION
1. Handwheel Nut	Ductile Iron ASTM A536
2. Identification Plate	Aluminum
3. Handwheel	Fabricated Steel
4. Yoke Bushing	Ductile Iron ASTM A536
5. Split Yoke Bolt	Steel ASTM A307/SAE J429
6. Split Yoke Bolt Nut	Steel ASTM A563
7. Yoke	Ductile Iron ASTM A536
8. Eye Bolt Nut	STEEL ASTM A563
9. Gland Follower	Ductile Iron ASTM A536
10. Yoke Bolt	Steel ASTM A307/SAE J429
11. Yoke Bolt Nut	Steel ASTM A563
12. Gland Follower Eye Bolt	Steel ASTM A307/SAE J429
13. Packing Gland	Stainless Steel ASTM A276
14. Packing	PTFE Braided
15. Backseat Bushing	Stainless Steel ASTM A276
16. Bonnet	Ductile Iron ASTM A395
17. Stem	Stainless Steel ASTM A 276
18. Bonnet Bolt	Steel ASTM A307/SAE J429
19. Bonnet Bolt Nut	Steel ASTM A563
20. Bonnet Gasket	Synthetic Fibers
21. Body	Ductile Iron ASTM A395
22. Wedge	Ductile Iron ASTM A395
23. ¹ Seat Ring	Stainless Steel ASTM A 351 CF8M
24. Wedge Ring	Stainless Steel ASTM A351 CF8M
25. Swing Nut	Steel ASTM A563
26. Swing Bolt	Steel ASTM A307/SAE J429
27. Grease Fitting	Alemite 1743B (not shown)
28. Stem Collar	Stainless Steel ASTM A276 (not shown)
29. Wedge Pin	Stainless Steel ASTM A276 (not shown)
30. Wedge Nut	Stainless Steel ASTM A276 (not shown)

¹Lugs may be removed at customer's request – POA.

DIMENSIONS—WEIGHTS—QUANTITIES

Size	Dimensions										Turns to Open	Weight		
	A	B	C	D	E	A	B	C	D	E		Lbs.	Kg.	
14	350	15.00	381	65.50	1664	24.00	610	21.00	533	1.38	35	29.38	890	405
16	400	16.00	406	74.50	1892	24.00	610	23.50	597	1.44	37	33.50	1253	570
18	450	17.00	432	82.50	2096	24.00	610	25.00	635	1.56	40	37.63	1598	726
20	500	18.00	457	91.00	2311	30.00	762	27.50	699	1.69	43	41.88	2000	909
24	600	20.00	508	107.50	2731	30.00	762	32.00	813	1.88	48	50.06	2908	1322



F-637-33
Flanged-Raised Face

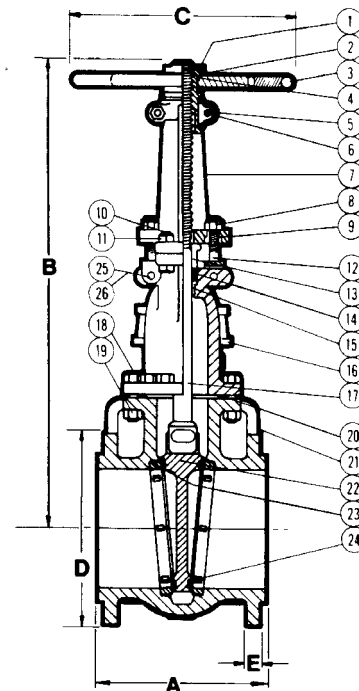

F-637-33
Flg x Flg

FREEZING WEATHER PRECAUTION: Subsequent to testing a piping system, valves should be left in an open position to allow complete drainage.

♦For detailed Operating Pressure, refer to Pressure Temperature Chart on page 114.

VISIT WWW.NIBCO.COM FOR CURRENT CHEM-GUIDE AND GALVANIC POTENTIAL IN PIPING SYSTEMS INFORMATION.

Visit our website for the most current information.

Class 150 Ductile Iron Body Gate Valves

Raised face flanges • bolted bonnet • non-rising stem •
solid wedge • B584 bronze trim

285 PSI/19.7 bar non-shock cold working pressure to -20°F to 100°F/-29°C to 38°C*

Maximum working temperature 650°F/343°C at 125 PSI/8.6 bar

150 PSI/10.3 bar saturated steam to 366°F/186°C

CONFORMS TO MSS SP-128

MATERIAL LIST

PART	SPECIFICATION
1. Handwheel Nut	Steel ASTM A563
2. Identification Plate	Aluminum
3. Handwheel	Iron ASTM A126 Class B
4. Stem	Brass ASTM B371 C69430/C69400
5. Gland Follower Nut	Brass ASTM F467
6. Gland Follower	Ductile Iron ASTM A536
7. Gland Follower Bolt	Steel ASTM A307/SAE J429
8. Packing Gland	Brass or Iron
9. Stuffing Box	Ductile Iron ASTM A536
10. Packing	PTFE Braided
11. Stuffing Box Gasket	Synthetic Fibers
12. Bonnet	Ductile Iron ASTM A395
13. Body Bolt	Steel ASTM A307/SAE J429
14. Body Gasket	Synthetic Fibers
15. Body Nut	Steel ASTM A563 C84400
16. ² Seat Ring	Brass ASTM B584 C84400
17. Wedge Face Ring	Brass ASTM B584
18. ¹ Wedge	Ductile Iron ASTM A395
19. Body	Ductile Iron ASTM A395
20. Stuffing Box Nut	Steel ASTM A563 (not shown)

¹Sizes thru 4" made with Bronze Wedges. Sizes 5" thru 12" made with Ductile Iron Wedge with Bronze Face Rings (31 Trim).

²Lugs may be removed at customer's request - POA.



F-639-31
Flanged-Raised Face

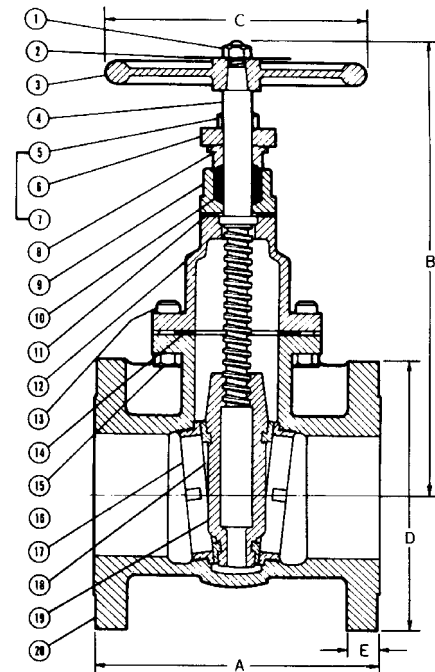

F-639-31
Flg x Flg

DIMENSIONS—WEIGHTS—QUANTITIES

Size	Dimensions										Weight		
	A		B		C		D		E		Lbs.	Kg.	
In. mm.	In. mm.	In. mm.	In. mm.	In. mm.	In. mm.	In. mm.	In. mm.	In. mm.	In. mm.				
2	50	7.00	178	11.00	279	7.00	178	6.00	152	.63	16	35	16
2½	65	7.50	191	12.50	318	7.00	178	7.00	178	.69	17	49	22
3	80	8.00	203	13.50	343	8.00	203	7.50	191	.75	19	60	27
4	100	9.00	229	15.75	400	10.00	254	9.00	229	.94	24	90	41
5	125	10.00	254	17.00	432	10.00	254	10.00	254	.94	24	129	59
6	150	10.50	267	21.00	533	12.00	305	11.00	279	1.00	25	161	73
8	200	11.50	292	25.00	635	14.00	356	13.50	343	1.13	29	278	126
10	250	13.00	330	29.00	737	16.00	406	16.00	406	1.19	30	419	190
12	300	14.00	356	34.50	876	18.00	457	19.00	483	1.25	32	631	286
14	350	15.00	381	40.38	1026	20.00	508	21.00	533	1.38	35	869	394
16	400	16.00	407	45.75	1162	22.00	559	23.50	597	1.44	37	1223	555

Position indicators available. See page 98

FREEZING WEATHER PRECAUTION: Subsequent to testing a piping system, valves should be left in an open position to allow complete drainage.

◆For detailed Operating Pressure, refer to Pressure Temperature Chart on page 114.

VISIT WWW.NIBCO.COM FOR CURRENT CHEM-GUIDE AND GALVANIC POTENTIAL IN PIPING SYSTEMS INFORMATION.

Visit our website for the most current information.

Class 150 Ductile Iron Body Gate Valves

Raised face flanges • bolted bonnet • non-rising stem •
solid wedge • 316 stainless steel trim

285 PSI/19.7 bar non-shock cold working pressure to -20°F to 100°F/-29°C to 38°C*

Maximum working temperature 650°F/343°C at 125 PSI/8.6 bar

150 PSI/10.3 bar saturated steam to 366°F/186°C

CONFORMS TO MSS SP-128

MATERIAL LIST

PART	SPECIFICATION
1. Handwheel Nut	Steel ASTM A307
2. Identification Plate	Aluminum
3. Handwheel	Iron ASTM A126 Class B
4. Stem	Stainless Steel ASTM A276
5. Gland Follower Nut	Steel ASTM A307
6. Gland Follower	Ductile Iron ASTM A536
7. Gland Follower Bolt	Steel ASTM A307/SAE J429
8. Packing Gland	Stainless Steel ASTM A276
9. Stuffing Box	Ductile Iron ASTM A536
10. Packing	PTFE Braided
11. Stuffing Box Gasket	Synthetic Fibers
12. Bonnet	Ductile Iron ASTM A395
13. Body Bolt	Steel ASTM A307/SAE J429
14. Body Gasket	Synthetic Fibers
15. Body Nut	Steel ASTM A307
16. ¹ Seat Ring	Stainless Steel ASTM A351 CF8M
17. Wedge Face Ring	Stainless Steel ASTM A351 CF8M
18. Wedge	Ductile Iron ASTM A395
19. Body	Ductile Iron ASTM A395
20. Stuffing Box Nut	Steel ASTM A307 (not shown)

¹Lugs may be removed at customer's request – POA.



F-639-33
Flanged-Raised Face

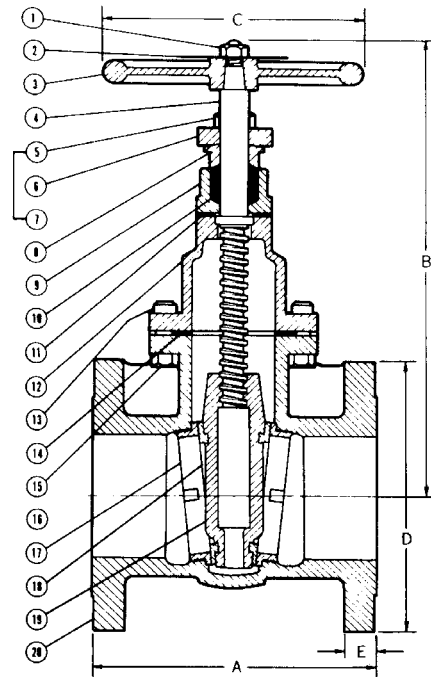

F-639-33
Flg x Flg

DIMENSIONS—WEIGHTS—QUANTITIES

Size	Dimensions										Weight		
	A		B		C		D		E		Lbs.	Kg.	
In.	mm.	In.	mm.	In.	mm.	In.	mm.	In.	mm.	In.	mm.	Lbs.	Kg.
2	50	7.00	178	11.00	279	7.00	178	6.00	152	.63	16	35	16
2½	65	7.50	191	12.50	318	7.00	178	7.00	178	.69	17	49	22
3	80	8.00	203	13.50	343	8.00	203	7.50	191	.75	19	60	27
4	100	9.00	229	15.75	400	10.00	254	9.00	229	.94	24	90	41
5	125	10.00	254	17.00	432	10.00	254	10.00	254	.94	24	129	59
6	150	10.50	267	21.00	533	12.00	305	11.00	279	1.00	25	161	73
8	200	11.50	292	25.00	635	14.00	356	13.50	343	1.13	29	278	126
10	250	13.00	330	29.00	737	16.00	406	16.00	406	1.19	30	419	190
12	300	14.00	356	34.50	876	18.00	457	19.00	483	1.25	32	631	286
14	350	15.00	381	40.38	1026	20.00	508	21.00	533	1.38	35	869	394
16	400	16.00	407	45.75	1162	22.00	559	23.50	597	1.44	37	1223	555

Position indicators available. See page 98.





FREEZING WEATHER PRECAUTION: Subsequent to testing a piping system, valves should be left in an open position to allow complete drainage.

◆ For detailed Operating Pressure, refer to Pressure Temperature Chart on page 114.

VISIT WWW.NIBCO.COM FOR CURRENT CHEM-GUIDE AND GALVANIC POTENTIAL IN PIPING SYSTEMS INFORMATION.

Visit our website for the most current information.

Ductile and Alloy Iron Globe, Angle and Check Valves Illustrated Index

<p>Ductile Iron Body Globe Valve Outside Screw and Yoke Brass Trim Class 150 SWP 250 lb. CWP</p>  <p>F-738-31 Brass Disc Sizes 2" thru 10" Flanged-Raised Face Page 84</p>	<p>Ductile Iron Body Angle Valve Outside Screw and Yoke Brass Trim Class 150 SWP 250 lb. CWP</p>  <p>F-838-31 Brass Disc Sizes 2" thru 8" Flanged-Raised Face Page 85</p>	<p>3% Nickel Iron Body Check Valve Stainless Steel Trim Class 125 SWP 200 lb. CWP</p>  <p>F-918-13 Stainless Steel Disc Sizes 2" thru 12" Flanged Ends Page 86</p>
<p>Lead Free Ductile Iron Body Swing Check Valve Brass Trim Class 150 SWP 250 lb. CWP</p>  <p>F-938-31 Brass Disc Sizes 2" thru 12" Flanged-Raised Face Page 87</p>	<p>Ductile Iron Body Swing Check Valve 316SS Stainless Steel Trim Class 150 SWP 250 lb. CWP</p>  <p>F-938-33 Stainless Steel Disc Sizes 2" thru 12" Flanged-Raised Face Page 88</p>	<p>Why Ductile Iron? Page 89</p> <p>How Ductile Iron Compares to Cast Iron and Cast Steel. Page 90</p> <p>Construction Features. Page 91</p> <p>Ductile Iron Valve Specifications . . Page 92</p>

NOTE: Check valves should never be installed immediately adjacent to a pump discharge or change in direction. Check Valves should be installed downstream from all sources of line turbulence, including fittings and valves, at a minimum of 5x the nominal pipe diameter (preferably 10x) with straight piping to provide laminar flow.

VISIT WWW.NIBCO.COM FOR CURRENT CHEM-GUIDE AND GALVANIC POTENTIAL IN PIPING SYSTEMS INFORMATION.

Visit our website for the most current information.

Class 150 Ductile Iron Body Globe Valves

Raised face flanges • bolted bonnet • outside screw and yoke • bronze trim

285 PSI/19.7 bar non-shock cold working pressure to -20°F to 100°F/-29°C to 38°C*

Maximum working temperature 650°F/343°C at 125 PSI/8.6 bar

150 PSI/10.3 bar saturated steam to 366°F/186°C

TESTING SPECIFICATION TO MSS SP-85

MATERIAL LIST

PART	SPECIFICATION
1. Handwheel Nut	Steel ASTM A563
2. Identification Plate	Aluminum
3. Handwheel	Iron ASTM A126 Class B
4. Yoke Bushing	Brass ASTM B584
5. Bonnet	Ductile Iron ASTM A395
6. Stem	Brass ASTM B371 Alloy C69400 or C69430
7. Gland Follower Nut	Brass ASTM F467 Alloy C27000
8. Gland Follower	Ductile Iron ASTM A536
9. Packing Gland	Zinc Plated Powdered Iron ASTM B 310 or Brass ASTM B371 C69300
10. Gland Follower Stud	Steel ASTM A307/SAE J429
11. Packing	PTFE Braided
12. ¹ Body Bolt	Steel ASTM A307/SAE J429
13. Body Gasket	Synthetic Fibers
14. ² Body Nut	Steel ASTM A563
15. Swivel Nut	Brass ASTM B584 Alloy C84400
16. ² Disc	Brass ASTM B584 Alloy C84400
17. Seat Ring	Brass ASTM B584 Alloy C84400
18. Body	Ductile Iron ASTM A395

¹2" and 10" have hex head steel capscrew.

²2" thru 6" have Bronze ASTM B584 Disc. 8" thru 10" have Ductile Iron Disc with Bronze ASTM B584 Disc Face Rings and Brass Pilots.



F-738-31
Flanged-Raised Face

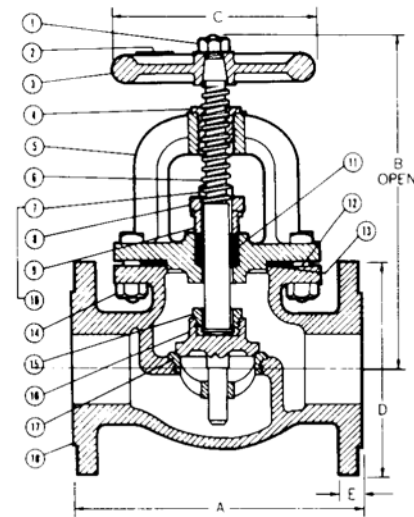

F-738-31
Flg x Flg

DIMENSIONS—WEIGHTS—QUANTITIES

Size	Dimensions										Weight		
	A		B		C		D		E		Lbs.	Kg.	
In.	mm.	In.	mm.	In.	mm.	In.	mm.	In.	mm.	In.	mm.		
2	50	8.00	203	10.19	259	7.00	178	6.00	152	.63	16	32	15
2½	65	8.50	216	11.81	300	8.00	203	7.00	178	.69	17	49	22
3	80	9.50	241	12.50	318	8.00	203	7.50	191	.75	19	66	30
4	100	11.50	292	15.81	402	10.00	254	9.00	229	.94	24	98	45
5	125	13.00	330	16.50	419	10.00	254	10.00	254	.94	24	139	63
6	150	14.00	356	18.88	479	12.00	305	11.00	279	1.00	25	183	83
8	200	19.50	495	21.13	537	16.00	406	13.50	343	1.13	29	362	164
10	250	24.50	622	25.19	640	18.00	457	16.00	406	1.19	30	582	264

Install 5 pipe diameters minimum downstream from pump discharge or changes in direction to avoid flow turbulence. Flow straighteners may be required in extreme cases.

FREEZING WEATHER PRECAUTION: Subsequent to testing a piping system, valves should be left in an open position to allow complete drainage.

VISIT WWW.NIBCO.COM FOR CURRENT CHEM-GUIDE AND GALVANIC POTENTIAL IN PIPING SYSTEMS INFORMATION.

Visit our website for the most current information.

◆ For detailed Operating Pressure, refer to Pressure Temperature Chart on page 114.

Class 150 Ductile Iron Body Angle Valves

Raised face flanges • bolted bonnet • outside screw and yoke • bronze trim

285 PSI/19.7 bar non-shock cold working pressure to -20°F to 100°F/-29°C to 38°C*

Maximum working temperature 650°F/343°C at 125 PSI/8.6 bar

150 PSI/10.3 bar saturated steam to 366°F/186°C

TESTING SPECIFICATION TO MSS SP-85

MATERIAL LIST

PART	SPECIFICATION
1. Handwheel Nut	Steel ASTM A563
2. Identification Plate	Aluminum
3. Handwheel	Iron ASTM A126 Class B
4. Yoke Bushing	Brass ASTM B584
5. Bonnet	Ductile Iron ASTM A395
6. Stem	Brass ASTM B371 Alloy C69400 or C69430
7. Gland Follower Nut	Brass ASTM F467 Alloy C27000
8. Gland Follower Stud	Steel ASTM A307/SAE J429
9. Gland Follower	Ductile Iron ASTM A536
10. Packing Gland	Zinc Plated Powdered Iron ASTM B 310 or Brass ASTM B 372 C69400
11. Packing	PTFE Braided
12. ¹ Body Bolt	Steel ASTM A307/SAE J429
13. Body Gasket	Synthetic Fibers
14. ¹ Body Nut	Steel ASTM A563
15. Swivel Nut	Brass ASTM B584 Alloy C84400
16. ² Disc	Brass ASTM B584 Alloy C84400
17. Seat Ring	Brass ASTM B584 Alloy C84400
18. Body	Ductile Iron ASTM A395

¹2" have hex head steel capscrew.

²For Disc 2" thru 6" have Bronze ASTM B584 Disc. 8" thru 10" have Ductile Iron Disc with Bronze ASTM B584 Disc Face Rings and Brass Pilots.

Consult Factory for non-return feature. Fig. No. F-838-31NR.



F-838-31
Flanged-Raised Face

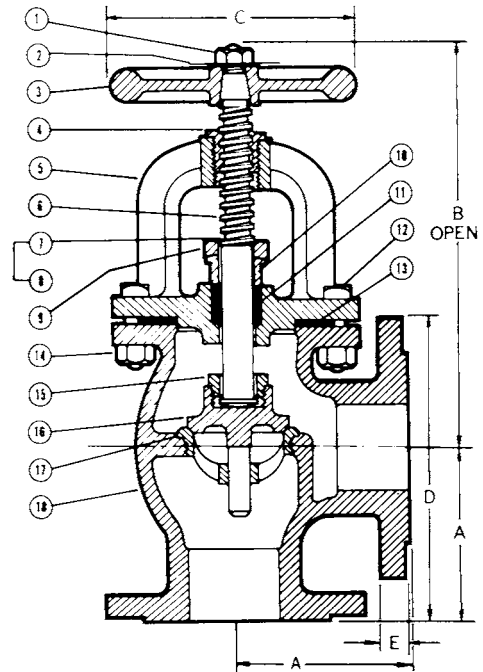

F-838-31
Flg x Flg

DIMENSIONS—WEIGHTS—QUANTITIES

Size	Dimensions										Weight	
	A		B		C		D		E		Lbs.	Kg.
In. mm.	In.	mm.	In.	mm.	In.	mm.	In.	mm.	In.	mm.		
2 50	4.00	102	10.00	254	7.00	178	6.00	152	.63	16	30	14
2½ 65	4.25	108	11.50	292	8.00	203	7.00	178	.69	17	51	23
3 80	4.75	121	12.25	311	8.00	203	7.50	191	.75	19	60	27
4 100	5.75	146	15.00	381	10.00	254	9.00	229	.94	24	99	45
5 125	6.50	171	16.50	419	10.00	254	10.00	254	.94	24	132	60
6 150	7.00	178	18.88	479	12.00	305	11.00	279	1.00	25	188	85
8 200	9.75	248	20.75	527	16.00	406	13.50	343	1.13	29	349	158

Install 5 pipe diameters minimum downstream from pump discharge or changes in direction to avoid flow turbulence. Flow straighteners may be required in extreme cases.

FREEZING WEATHER PRECAUTION: Subsequent to testing a piping system, valves should be left in an open position to allow complete drainage.

VISIT WWW.NIBCO.COM FOR CURRENT CHEM-GUIDE AND GALVANIC POTENTIAL IN PIPING SYSTEMS INFORMATION.

Visit our website for the most current information.

◆ For detailed Operating Pressure, refer to Pressure Temperature Chart on page 114.

Class 125 3% Nickel Iron Body Check Valves

Bolted bonnet • renewable seat and disc* • stainless steel trim

200 PSI/13.8 bar non-shock cold working pressure to -20°F to 150°F/-29°C to 66°C†
Maximum working temperature 450°F/232°C at 125 PSI/8.6 bar
125 PSI/8.6 bar saturated steam to 353°F/178°C

CONFORMS TO MSS SP-71

MATERIAL LIST

PART	SPECIFICATION
1. Body Bolt ¹	Steel ASTM A307
2. Identification Plate	Aluminum
3. Bonnet	ASTM A126 3% Nickel Iron Class B
4. Body Gasket	Synthetic Fibers
5. Nut	Steel ASTM A563
6. Side Plug	ASTM A 193 B8M S31600SS
7. Hanger Pin	Ductile Iron ASTM A536
8. Hanger	Ductile Iron ASTM A395
9. Disc ²	ASTM A351 CF8M
10. Seat Ring	ASTM A351 CF8M
11. Disc Nut	ASTM A194 B8M S31600 SS
12. Body	ASTM A126 3% Nickel Iron Class B
13. Disc Bolt ²	ASTM A276 S31600 Stainless Steel

¹2" and 10" have hex head steel capscrew

²2"-4" SST ASTM A351 CF8M disc

⁵5"-12" 3% nickel iron disc with SST disc face ring and disc bolt

DIMENSIONS—WEIGHTS—QUANTITIES

Size	Dimensions								Weight		
	A		B		D		E		Lbs.	Kg.	
In.	mm.	In.	mm.	In.	mm.	In.	mm.	In.	mm.		
2	50	8.00	203	3.94	100	6.00	152	.63	16	24	11
2½	65	8.50	216	4.50	114	7.00	178	.69	17	35	16
3	80	9.50	241	5.13	130	7.50	191	.75	19	47	21
4	100	11.50	292	6.13	156	9.00	229	.94	24	80	36
6	150	14.00	356	8.00	203	11.00	279	1.00	25	146	66
8	200	19.50	495	9.44	240	13.50	343	1.13	29	255	116
10	250	24.50	622	12.06	306	16.00	406	1.19	30	426	193
12	300	27.50	699	16.13	410	19.00	483	1.25	32	657	298

*Proper machining facilities required.

Note: On pump discharge, the preferred check valves are:

- inline, spring assisted, center-guided, lift checks
- spring assisted twin (double) disc
- swing design with lever and weight or lever and spring

Install 5 pipe diameters minimum downstream from pump discharge or changes in direction to avoid flow turbulence. Flow straighteners may be required in extreme cases.

NIBCO® Check Valves may be installed in both horizontal and vertical lines with upward flow or in any intermediate position.

Warning: Do not use for Reciprocating Air Compressor Service.



F-918-13
Flanged

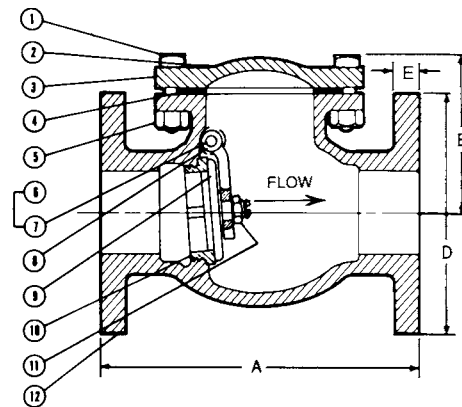

F-918-13
Flg x Flg

Class 150 Ductile Iron Body Swing Check Valves

Raised face flanges • bolted bonnet • bronze trim

285 PSI/19.7 bar non-shock cold working pressure to -20°F to 100°F/-29°C to 38°C*

Maximum working temperature 650°F/343°C at 125 PSI/8.6 bar

150 PSI/10.3 bar saturated steam to 366°F/186°C

CONFORMS TO MSS SP-136

MATERIAL LIST

PART	SPECIFICATION
1. Bolt	Steel ASTM A307
2. Identification Plate	Aluminum
3. Bonnet	Ductile Iron ASTM A395
4. Body Gasket	Synthetic Fibers
5. Nut	Steel ASTM A563
6. Side Plug	Brass ASTM B584 C84400
7. Hanger Pin	Brass ASTM B371 C69430/C69400
8. Hanger	Ductile Iron ASTM A536
9. Disc ¹	Brass ASTM B584 C84400
10. Seat Ring	Brass ASTM B584 C84400
11. Disc Nut	Brass ASTM B371 C69430/C69400
12. Body	Ductile Iron ASTM A395
13. Disc Bolt ¹	Brass ASTM B371 C69430/C69400

¹2"-4" bronze disc

¹5"-12" ductile iron disc with bronze face ring and disc bolt



F-938-31
Flanged-Raised Face

DIMENSIONS—WEIGHTS—QUANTITIES

Size	Dimensions										Weight	
	A		B		D		E		Lbs.	Kg.		
In.	mm.	In.	mm.	In.	mm.	In.	mm.	In.	mm.			
2	50	8.00	203	3.94	100	6.00	152	.63	16	24	11	
2½	65	8.50	216	4.50	114	7.00	178	.69	17	35	16	
3	80	9.50	241	5.13	130	7.50	191	.75	19	47	21	
4	100	11.50	292	6.13	156	9.00	229	.94	24	81	37	
5	125	13.00	330	6.81	173	10.00	254	.94	24	100	45	
6	150	14.00	356	8.00	203	11.00	279	1.00	25	146	66	
8	200	19.50	495	9.44	240	13.50	343	1.13	29	255	116	
10	250	24.50	622	12.06	306	16.00	406	1.19	30	426	193	
12	300	27.50	699	16.13	410	19.00	483	1.25	32	660	299	

Lever and Weight/Spring Options available only in 3", 4" and 6". (see page 101)

Note: On pump discharge, the preferred check valves are:

- inline, spring assisted, center-guided, lift checks
- spring assisted twin (double) disc
- swing design with lever and weight or lever and spring

Install 5 pipe diameters minimum downstream from pump discharge or changes in direction to avoid flow turbulence. Flow straighteners may be required in extreme cases.

NIBCO® Check Valves may be installed in both horizontal and vertical lines with upward flow or in any intermediate position.

WARNING: Do not use for Reciprocating Air Compressor Service.

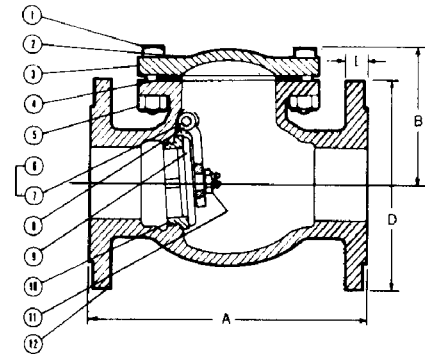

F-938-31
Flg x Flg

Class 150 Ductile Iron Body Swing Check Valves

Raised face flanges • bolted bonnet • 316 stainless steel trim

285 PSI/19.7 bar non-shock cold working pressure to -20° F to 100° F/-29° C to 38° C*
Maximum working temperature 650°F/343°C at 125 PSI/8.6 bar
150 PSI/10.3 bar saturated steam to 366°F/186°C



CERTIFIED LEAD-FREE* TO NSF/ANSI-61-8 (INCLUDES ANNEX F AND G) AND NSF/ANSI-372
CONFORMS TO MSS SP-136

MATERIAL LIST

PART	SPECIFICATION
1. Bolt	Steel ASTM A307
2. Identification Plate	Aluminum
3. Bonnet	Ductile Iron ASTM A395
4. Body Gasket	Synthetic Fibres
5. Nut	Steel ASTM A563
6. Side Plug	Stainless Steel ASTM A193 B8M
7. Hanger Pin	Stainless Steel ASTM A276
8. Hanger	Ductile Iron ASTM A395
9. Disc ¹	Stainless Steel ASTM A351 CF8M
10. Seat Ring	Stainless Steel ASTM A351 CF8M
11. Disc Nut	Stainless Steel ASTM A351 CF8M
12. Body	Ductile Iron ASTM A395
13. Disc Bolt ¹	Stainless Steel UNS S31600

¹2"-4" stainless steel disc

¹5"-12" ductile iron disc with SST disc face ring and disc bolt



F-938-33
Flanged-Raised Face

DIMENSIONS—WEIGHTS—QUANTITIES

Size	Dimensions								Weight		
	A		B		D		E		Lbs.	Kg.	
In.	mm.	In.	mm.	In.	mm.	In.	mm.	In.	mm.		
2	50	8.00	203	3.94	100	6.00	152	.63	16	24	11
2½	65	8.50	216	4.50	114	7.00	178	.69	17	35	16
3	80	9.50	241	5.13	130	7.50	191	.75	19	47	21
4	100	11.50	292	6.13	156	9.00	229	.94	24	80	36
5	125	13.00	330	6.81	173	10.00	254	.94	24	100	46
6	150	14.00	356	8.00	203	11.00	279	1.00	25	146	66
8	200	19.50	495	9.44	240	13.50	343	1.13	29	274	125
10	250	24.50	622	12.06	306	16.00	406	1.19	30	426	194
12	300	27.50	699	16.13	410	19.00	483	1.25	32	655	298

Lever and Weight/Spring Options available only in 3", 4" and 6". (see page 101)

Note: On pump discharge, the preferred check valves are:

- inline, spring assisted, center-guided, lift checks
- spring assisted twin (double) disc
- swing design with lever and weight or lever and spring

Install 5 pipe diameters minimum downstream from pump discharge or changes in direction to avoid flow turbulence. Flow straighteners may be required in extreme cases.

NIBCO® Check Valves may be installed in both horizontal and vertical lines with upward flow or in any intermediate position.

WARNING: Do not use for Reciprocating Air Compressor Service.

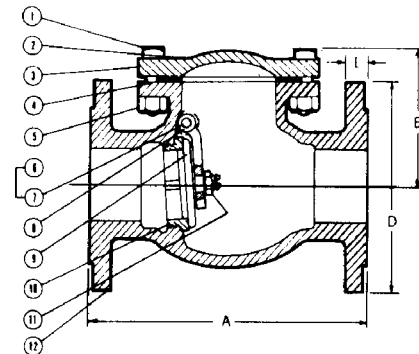

F-938-33
Flg x Flg

*Weighted average lead content ≤ 0.25%

VISIT WWW.NIBCO.COM FOR CURRENT CHEM-GUIDE AND GALVANIC POTENTIAL IN PIPING SYSTEMS INFORMATION.

Visit our website for the most current information.

◆ For detailed Operating Pressure, refer to Pressure Temperature Chart on page 114.

Why Ductile Iron?

NIBCO is the largest United States manufacturer of pressure rated Ductile Iron Valves. NIBCO Ductile Iron multi-turn valves are ideal for a wide variety of services: hydrocarbons, chemical, marine, fire protection services, pulp and paper applications where cast iron and/or cast steel valves could be installed.

Ductile Iron, also known as nodular iron, was developed in 1949 as a substitute for steel. Cast steel contains carbon of less than .3% by weight, while cast and ductile irons have at least 3% total carbon. This low carbon content in cast steel does not allow the carbon to form as free graphite resulting in a laminate type of structure. The natural form of carbon in cast iron is the free graphite flake form. In Ductile Iron, this graphite flake is modified by a specialized treatment process to form tiny spheres or nodules. These modified graphite nodules provide Ductile Iron with physical properties greater than cast iron and comparable to steel. It is this nodular microstructure of carbon in Ductile Iron which produces high ductility and shock resistance while the flake form of cast iron results in no malleability. Optimum ductility is obtained with a ferritic matrix, therefore, all NIBCO Ductile Iron pressure containing parts are treated with a ferritizing annealing cycle. In Ductile Iron spheroidal nodules also eliminate the crack effect of flake graphite which is exhibited in cast iron. In microscopic photos of Ductile Iron, cracks can be seen traveling to a graphite nodule and stopping. These graphite spheroids are known as "crack arresters" in the Ductile Iron industry because of their ability to stop cracks in their tracks.

In some circles, Ductile Iron is known as the metal that is the "best of both worlds" meaning that Ductile Iron combines the superior strength of cast steel with the excellent corrosion resistance of cast iron.

Ductile Iron vs. Cast (Gray) Iron

The strength of Ductile Iron when compared to cast iron is overwhelming. Ductile Iron tensile strength is 60k versus cast iron at 31k. Ductile Iron has a yield strength of 40k, whereas cast iron exhibits no yield, only ultimate fracture. Ductile Iron strength-to-cost ratio offers greater value for a marginal increase in cost over cast iron. (See page 89 for a complete comparison of mechanicals.) Ductile Iron offers excellent corrosion resistance that is equivalent to cast iron.

Ductile Iron vs. Cast Steel

The strengths of Ductile Iron and cast steel are comparable. Ductile Iron has a higher minimum yield strength at 40k versus cast steel at 36k. (See page 89 for a more complete comparison of mechanicals.) Ductile Iron has corrosion and oxidation resistance that surpasses cast steel in most general utility service applications. Because of Ductile Iron's spheroidal graphite microstructure, Ductile Iron is superior to steel in its ability to deaden vibration and therefore reduce stresses. An important factor in selecting Ductile Iron over cast steel is cost. The lower expense of Ductile Iron results from readily available materials, foundry operation efficiencies and reduced machining costs of Ductile Iron.



Cast (Gray) Iron
Flake Form

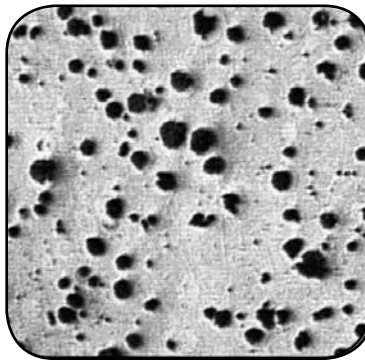

Ductile Iron
Spheroidal Graphite Nodules

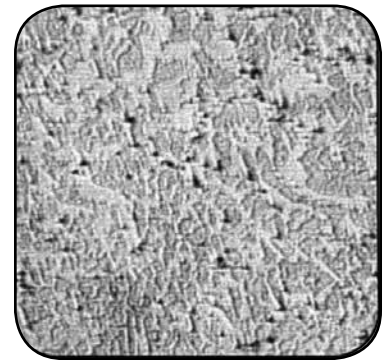

Cast Steel Form

NOTE: For our metal comparison, NIBCO has chosen to use ASTM A395 Ductile Iron, ASTM A126 Cast Iron and ASTM A216 WCB Cast Steel. Wherever Cast Iron is listed, we are referring to Gray Iron.

Visit our website for the most current information.

How Ductile Iron Compares to Cast Iron and Cast Steel

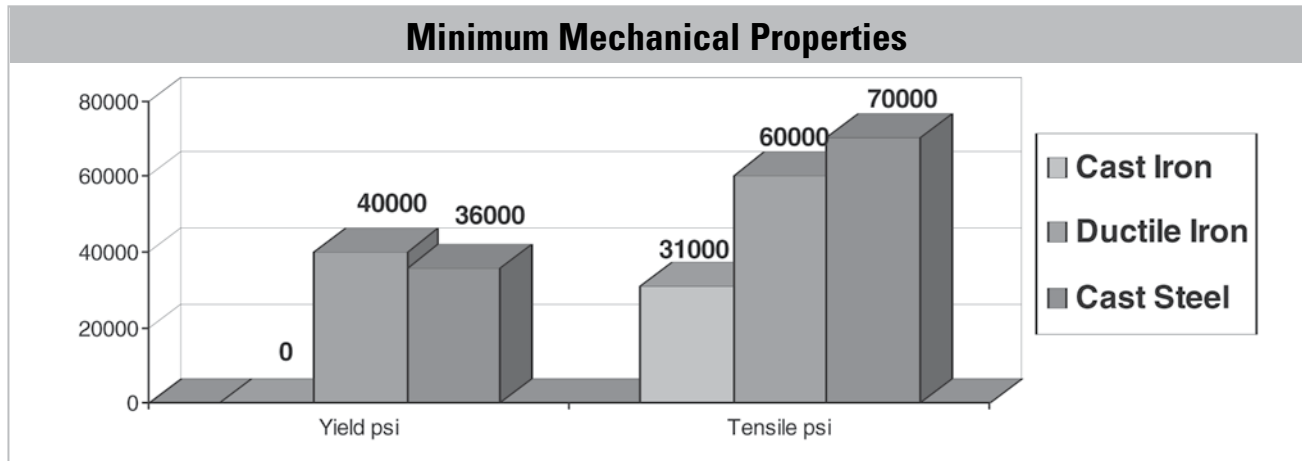

Chemical Analysis

	Cast Iron ASTM A126 Class B*	Ductile Iron ASTM A395	Cast Steel ASTM A216 WCB
Iron and Residuals%	94.0	94.5	98.1
Carbon%	3.3	3.0	0.3
Silicon%	2.0	2.5	0.6
Manganese%	0.7		1.0

* Typical composition, ASTM Standard does not specify materials to this detail.

Pressure/Temperature Ratings Comparing Cast Iron, Ductile Iron and Cast Steel

°F/°C Temperature	ASTM A126 Cast Iron		ASTM A395 *Ductile Iron	ASTM A216 WCB Cast Steel
	Class 125		Class 150	Class 150
	2"-12"	14"-24"	2"-24"	2"-24"
-20°F-100°F	200 psi	150 psi	250 psi	285 psi
150°F/66°C	200 psi	150 psi	243 psi	
200°F/93°C	190 psi	135 psi	235 psi	260 psi
250°F/121°C	175 psi	125 psi	225 psi	
300°F/149°C	165 psi	110 psi	215 psi	230 psi
350°F/177°C	150 psi	100 psi	210 psi	
400°F/204°C	140 psi		200 psi	200 psi
450°F/232°C	125 psi		185 psi	
500°F/260°C			170 psi	170 psi
550°F/288°C			155 psi	
600°F/316°C			140 psi	140 psi
650°F/343°C			125 psi	125 psi

* These ratings apply when temperature exceeds 450°F and the valve has 316 SS trim. When ASTM B584 trim is used, maximum temperature limit is 450°F.

Visit our website for the most current information.

Construction Features

Flanges	NIBCO® Ductile Iron Valves come standard ASME B16.42 Class 150 flanges and the same end-to-end dimensions as Class 125 iron or Class 150 steel valves. Thus Ductile Iron valves can easily replace cast iron or steel valves. NIBCO also offers PN10/16 flanges per BS 4504 and compliant to BS 5150 face-to-face dimensions.
Trim	Bronze ASTM B584, 316 Stainless Steel
Test Pressures	All NIBCO Ductile Iron Valves are tested to MSS requirements in our ISO 9002 quality certified manufacturing plant in Blytheville, Arkansas.
Color	NIBCO Ductile Iron valves are painted green in compliance with API 604.

Features and Benefits

Strength	Ductile Iron is a very strong material when compared to cast iron and comparable to cast steel. Ductile Iron has a higher yield strength than cast steel 40K vs. 30K. The strength of Ductile Iron when compared to cast iron is overwhelming. Ductile Iron tensile strength is 60K vs Cast Iron at 31K. Ductile Iron has yield strength of 40K and cast iron has none.
Corrosion Resistance	Ductile Iron has a corrosion and oxidation resistance in most cases that surpasses cast steel and is slightly better than cast iron. Oxide penetration can severely affect the strength and performance of valves.
Low Transition Temps	Ferrous metals are subject to brittle fractures with severe temperature changes. The chemical composition of NIBCO's Ductile Iron provides transition temperatures to -20°F. This property is important if physical shock loading is present in cold weather applications.
Cost Effective	These unique characteristics make Ductile Iron a cost-effective option for 150 psi steam service as well as hydrocarbon processing up to 650°F/343°C.

Applications

Steam Service	Ductile Iron gate, globe and check valves are excellent choices for 150 psi steam service. Available with ASTM B584 bronze trim and CF8M SS trim.
Hydrocarbon Service	Ductile Iron is an acceptable substitute for cast steel in a wide range of processing services both on the production and refining side up to 650°F/343°C.
General Service	Ductile Iron can substitute for standard Class 125 cast iron where there may be concerns with potential stresses and a stronger material is desired, i.e. in situations of unusual pipe movement due to the system or external forces, such as cold weather, earthquakes, etc. Ductile Iron may be substituted for Class 250 cast iron for intermediate pressure services using Class 150 flanges up to 250 psi wwp. (Should save on valve and flange costs.) Ductile Iron is a good choice for general service, fire protection and Hi-rise applications. Has a higher application temperature than PTFE seated flanged ball valves.
Marine Service	For shipboard application and tanker piping, many marine agencies recommend the use of Ductile Iron Valves because of its resistance to shock, vibration and superior corrosion-resistant properties. Approved by DOT and Certificate of Approval from Lloyds Register of Shipping.

Visit our website for the most current information.

Ductile Iron Valve Specifications

VALVES 2 1/2" AND LARGER — 250 PSI CWP APPLICATION

Gate Valves

Valves to be Class 150 and 250 PSI CWP, tested in accordance with Manufacturers Standardization Society, flanged, bolted bonnet, OS&Y or Non-Rising, Ductile Iron body, bronze trimmed, with body and bonnet conforming to ASTM A395 Ductile Iron. Packing and gaskets to be non-asbestos.

ACCEPTABLE VALVES: NIBCO F-637-31 (OS&Y) or F-639-31 (Non-Rising).

Globe/Angle Valves

Valves to be Class 150 and 250 PSI CWP, tested in accordance with Manufacturers Standardization Society, flanged, bolted bonnet, OS&Y, Ductile Iron body, bronze trimmed, with body and bonnet conforming to ASTM A395 Ductile Iron. Packing and gaskets to be non-asbestos.

ACCEPTABLE VALVES: Straight Globe NIBCO F-738-31; Angle Globe NIBCO F-838-31.

Check Valves

Valves to be Class 150 and 250 PSI CWP, shall be swing-type tested in accordance with Manufacturers Standardization Society, flanged, bolted bonnet, Ductile Iron body, bronze trimmed, with body and bonnet conforming to ASTM A395 Ductile Iron, non-asbestos gasket.

ACCEPTABLE VALVES: Swing-type NIBCO F-938-31; Swing-type with outside lever and spring/weight NIBCO F-938-31-BL&S (BL&W).

VALVES 2 1/2" AND LARGER — HIGH PRESSURE STEAM/HYDROCARBON

Gate Valves

Valves to be Class 150 and 250 PSI CWP, tested in accordance with Manufacturers Standardization Society, flanged, bolted bonnet, OS&Y, Ductile Iron body, 316 SS trimmed, with body and bonnet conforming to ASTM A395 Ductile Iron. Packing and gaskets to be non-asbestos.

ACCEPTABLE VALVES: NIBCO F-637-33.

Globe/Angle Valves

Valves to be Class 150 and 250 PSI CWP, tested in accordance with Manufacturers Standardization Society, flanged, bolted bonnet, OS&Y, Ductile Iron body, bronze trimmed, with body and bonnet conforming to ASTM A395 Ductile Iron. Packing and gaskets to be non-asbestos.

APPLICABLE VALVES: Straight Globe NIBCO F-738-31; Angle Globe NIBCO F-838-31 Bronze Trim for Steam Application ONLY.

Check Valves

Valves to be Class 150 and 250 PSI CWP, shall be swing-type tested in accordance with Manufacturers Standardization Society, flanged, bolted bonnet, Ductile Iron body, 316 SS trimmed, with body and bonnet conforming to ASTM A395 Ductile Iron, non-asbestos gasket.

ACCEPTABLE VALVES: Swing-type NIBCO F-938-33; Swing-type with outside lever and spring/weight NIBCO F-938-33-BL&S (BL&W).

GLOSSARY OF TERMS

Ductility:

The ability of a material to become permanently deformed—stretched, drawn, or hammered without failure while maintaining an appreciable load.

Tensile Strength:

Measures in force per unit area [i.e. pounds per square inch (PSI)] the ultimate stress that can be withstood by a material in tension prior to failure.

Yield Strength:

Measures in force per unit area, the stress at which a material will undergo a permanent change in shape (plastic deformation) in response to an applied force.

Elongation:

Measures by percentage, the amount of plastic deformation a material will exhibit in response to a force applied in tension.

Oxide Penetration:

The depth of material deterioration or loss displayed along the surface of a metal that is exposed to highly corrosive (oxidizing) environment.

Bronze and Iron Valves

Options and Accessories Index

Bronze Valve

Options and Accessories

Handles.....	94
Seating and Packing.....	95
Drain Cap.....	96
Stem Extensions.....	96
Oxygen Service.....	96
Use of Silicone Lubricants.....	96

Iron Valve

Options and Accessories

Seating.....	97
Packing and Gaskets.....	97
Square Operating Nut.....	98
Position Indicator.....	98
Sprocket Rims.....	98
Stem Extensions.....	99
Floor Stands.....	100
Wall Tapping.....	101
Boss Locations.....	101
By-Passes.....	101
Lever and Weight/Spring.....	102
Use of Silicone Lubricants.....	102
Parts for Lever and Weight/Spring.....	103
Gear Operators.....	103

Visit our website for the most current information.

Bronze Valve Options and Accessories - Handles

Matrix of Bronze Valve Handwheel Diameters

Valve	T062142 PP 2½" Dia.	T062459 PP 2½" Dia.	T062143 PP 3¼" Dia.	T065573 PP 3¼" Dia.	T062144 PP 4½" Dia.	T065574 PP 4½" Dia.	T062145 PP 5⅝" Dia.	T065575 PP 5⅝" Dia.	T062146 PP 7" Dia.	Valve
111	1/4 - 3/8	1/2 - 3/4	1	1¼ - 1½		2 - 2½		3		GATE
113	1/4 - 3/8	1/2 - 3/4	1	1¼ - 1½		2 - 2½		3		
124	1/4 - 3/8	1/2	3/4 - 1	1¼	1½	2	2½	3		
131	1/4 - 3/8	1/2	3/4 - 1	1¼	1½	2	2½	3		
133	1/4 - 3/8	1/2	3/4 - 1	1¼	1½	2	2½	3		
134	1/4 - 3/8	1/2	3/4 - 1	1¼	1½	2	2½	3		
136	1/4 - 3/8	1/2	3/4 - 1	1¼	1½	2	2½	3		
154A	1/4 - 3/8	1/2	3/4 - 1	1¼	1½	2				
174A	1/4 - 3/8	1/2	3/4 - 1	1¼	1½	2				
174SS		1/2	3/4 - 1	1¼	1½	2				
176A	1/4 - 3/8	1/2	3/4 - 1	1¼	1½	2				
176SS		1/2	3/4 - 1	1¼	1½	2				
211	1/8 - 1/2	3/4	1 - 1¼		1½	2		2½ - 3		
235	1/8 - 3/8	1/2	3/4	1	1¼	1½ - 2	2	2½	3	
256AP		1/4 - 1/2		3/4	1	1¼ - 1½	2	2½	3	
275B		1/8 - 3/8	1/2	3/4 - 1	1	1¼ - 1½	2	2½	3	
275Y		1/4 - 3/8	1/2	3/4 - 1		1¼ - 1½	2	2½	3	
276AP		1/4 - 3/8	1/2	3/4	1	1¼ - 1½	2	2½	3	
311	1/4 - 1/2	3/4	1 - 1¼			2		2½ - 3		
335	1/8 - 3/8	1/2	3/4	1	1¼	1½ - 2			3	
375B		1/4 - 3/8	1/2	3/4	1	1¼ - 1½	2		3	
376AP		1/4 - 3/8	1/2	3/4	1	1¼ - 1½	2			

Malleable Iron ASTM A47

Available as standard for NIBCO® Bronze Gate and Globe Valves. Class 125, 150, 200, 300 lb. SWP Bronze Body Valves. ¼" thru Square Stem only.



Malleable

Red Bronze 85-5-5-5% ASTM B62

Available for some NIBCO® 125 lb. SWP Bronze Body Valves ⅝" thru 3". Used where standard handwheel would be out of reach or hand space is restricted. Specify by adding (K) to Fig. No., i.e. T-000-K. For field replacement, specify valve type and size. Square Stem Only.



Cross

Red Bronze 85-5-5-5% ASTM B62

Available for some NIBCO® 125 lb. SWP Bronze Body Valves ⅝" thru 2". Used where code requirements or personal preference dictate a bronze handwheel. Specify by adding (BHW) to Fig. No., i.e. T-000-BHW. For field replacement, specify valve type and size. Square Stem Only.



Bronze

Red Bronze 85-5-5-5% ASTM B62

Available for some NIBCO® 125 lb. SWP Bronze Body Valves. Used where standard handwheel would be out of reach or hand space is restricted. Square Stem only.



Solid Tee

Red Bronze 85-5-5-5% ASTM B62 or ASTM B16

Available for some NIBCO® 125 lb. SWP Bronze Body Valves thru 3". Use where valve might be subject to unauthorized use or tampering. Specify by adding (L) to Fig. No., i.e. T-000-L. For field replacement, specify valve type and size. Square Stem Only.



Lockshield

Red Bronze 85-5-5-5% ASTM B62

Available for some NIBCO® 125 lb. SWP Bronze Body Valves thru 3". Used as handle for lockshields. Specify – "Lockshield Key." For field replacement, specify valve type and size. Square Stem Only.





Lockshield Key

NIBCO INC. reserves the right to change materials, options and accessories without notice.

Visit our website for the most current information.

Bronze Valve Options and Accessories

Seating and Packing

Seating Material		
<p>Material: PTFE</p> <p>Max. Pressure: 300 SWP/600 CWP</p> <p>Max. Temperature: -20°F to 400°F</p> <p>Service: Oxygen, steam, and all services where the media being handled is not corrosive to the metallic parts of the valve. Available for some NIBCO valves. Specify by adding (Y) to Fig. No., i.e. T-000-Y</p>		
<p>Material: FKM</p> <p>Max. Pressure: 125 SWP/200 CWP</p> <p>Max. Temperature: -20°F to 300°F</p> <p>Service: Hydrocarbon service, mineral acids and salt solutions that are not corrosive to the metallic parts of the valve. Available for some NIBCO valves. Specify by adding (V) to Fig. No., i.e. T-000-V</p>		
<p>Material: Buna-N (Nitrile)</p> <p>Max. Pressure: 200 CWP</p> <p>Max. Temperature: -40°F to 180°F</p> <p>Service: Water, Oil, Gas. Available for some NIBCO valves. Specify by adding (W) to Fig. No., i.e. T-000-W</p>		
<p>Material: Bronze ASTM B 62</p> <p>Max. Pressure: 150 SWP/300 CWP</p> <p>Max. Temperature: 406°F</p> <p>Service: Provides good seating properties for clean moderate service. Should not be used for close throttling or for handling material containing abrasive or corrosive particles.</p>		
<p>Material: Bronze ASTM B 61</p> <p>Max. Pressure: 300 SWP/600 CWP</p> <p>Max. Temperature: 550°F</p> <p>Service: Provides good seating properties for clean moderate service. Should not be used for close throttling or for handling material containing abrasive or corrosive particles.</p>		
<p>Material: Nickel Alloy, Semi Plug Only</p> <p>Max. Pressure: 300 SWP/600 CWP</p> <p>Max. Temperature: 550°F</p> <p>Service: General service, nickel alloy material is durable and resists wear and the corrosive action of some dilute acids and alkalis. Available for 300 SWP Globe Valves.</p>		
<p>Material: Hardened Stainless Steel, Full Plug Only</p> <p>Max. Pressure: 300 SWP/600 CWP</p> <p>Max. Temperature: 550°F</p> <p>Service: Recommended for close throttling and most all severe conditions, not to exceed the valve ratings. Available for 200 and 300 SWP Globe and Angle Valves.</p>		
Packing Material		
<p>Aramid Fibers with Graphite.</p> <p>Offered as standard on NIBCO Bronze Valves.</p>		
<p>Solid PTFE Packing</p> <p>Offered as a field retrofit option on NIBCO Bronze Valves. Consult factory for price and availability.</p>		

NIBCO INC. reserves the right to change materials, options and accessories without notice.

Visit our website for the most current information.

Bronze Valves Options and Accessories

Drain Cap, Oxygen Service, Stem Extensions

1/8" Drain Cap

A fast and convenient means for draining sections of line between valves.
Specify by adding (D) to Fig. No., i.e. T-111-D.
(Applicable to figure numbers 111, 113 and 211 only.)



Optional Squared Stem Extension

Available for all NIBCO® Bronze Valves.
Made from ASTM B371 62 Alloy C69400 (rod).
Used when valves must be operated from a distance.
Adequate and rigid support must be provided for long stem extension units.
Specify valve size, figure number and length to be added to existing stem length (dimension A). 3" minimum length, 18" maximum length.

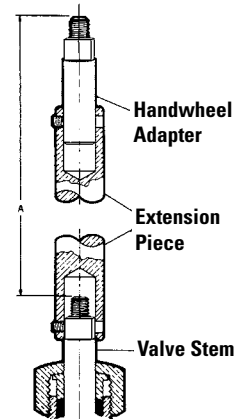

Oxygen Service; Bronze Gate, Globe and Check

The following valves are offered as oxygen cleaned and bagged. NIBCO figure number:
S/T-134-X
S/T-235-YX
S/T-413-YX
S/T-433-YX

Except for PTFE disc and packing, and identification tag, all parts are identical to standard valves.
Valves are thoroughly cleaned and degreased and individually packed in sealed polyethylene bags.
Consult with factory on availability for other bronze valves to be oxygen cleaned.



Silicone Lubricants in Nacogdoches, Texas, Plant

Below lists the two ways in which NIBCO® bronze gate, globe, check and ball valves are manufactured in our Nacogdoches plant:

1. Standard valves:

All pressure rated bronze gate, globe, check and bronze ball valves are manufactured in Nacogdoches, Texas. Silicone is **NOT** used in this plant in the production of valves or assembly of any component parts of the above listed products.

2. Valves can be cleaned for oxygen service:

- The steps involved are as follows:
- Clean ultrasonically all component parts with a degreaser in a warm water solution
- Rinse with warm water in an ultrasonic bath
- Rinse again in cold water
- Put all component parts under black light for inspection of any carbon. If carbon found, repeat steps above.
- Assemble and test valves
- Package the valves in a sealed plastic bag to avoid contamination

NOTE: Valves that are assembled and tested without silicone lubricants in this plant have a potential exposure to air-borne silicone as well as during shipping after they leave the plant. Therefore, NIBCO cannot certify valves produced in the Nacogdoches plant to be 100% silicone free.

NIBCO INC. reserves the right to change materials, options and accessories without notice.

Visit our website for the most current information.

Iron Valve Options and Accessories

Seating, Packing and Gasket Materials

Iron Valve Seating Material

Material: Bronze

Max. Pressure: 250 SWP/500 CWP
 Max. Temperature: 450°F
 Service: Steam-Water, Oil, and Gas. Standard on all NIBCO® Iron Body Valves unless otherwise specified.

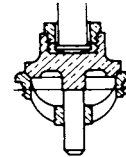

Material: PTFE

Max. Pressure: 250 SWP/500CWP
 Max. Temperature: 450°F
 Service: Oxygen, steam, and all services where the media being handled is not corrosive to the metallic parts of the valve. Standard on 2½" and 3" Automatic Stop Check.



NOTE: ASME B 31.1 Boiler and Pressure Vessel Code limits non-metallic seats to 150 PSI steam service.

Material: Iron

Max. Pressure: 200 CWP
 Max. Temperature: 250°F
 Service: Used where bronze trim is not permitted. Specify by adding (N) to Fig. No., i.e. F-000-N. Available for some NIBCO® Gate, Globe, Angle and Check Valves.

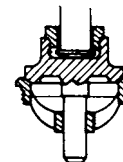

Packing and Gasket Materials

1. Standard NIBCO® iron valves are furnished with synthetic fibers and graphite packing, along with synthetic fibre gaskets. Temperature rated to 550°F. Class 250 iron valves are furnished with PTFE braided packing and reinforced graphite gaskets. For other special packing and gaskets, consult factory.
2. Alloy Iron Valves are furnished with PTFE braided packing and synthetic fibre gaskets.
3. Graphite packing and gaskets optional on some NIBCO Iron Valves. Consult factory.



NIBCO INC. reserves the right to change materials, options and accessories without notice.

Visit our website for the most current information.

Iron Valve Options and Accessories

Operating Nut, Position Indicator, Sprocket Rims

Square Operating Nut

The square operating nut can be substituted for the regular handwheel when an NRS (619 & 639) valve is to be installed in an inaccessible location. It may be operated by a key or a wrench. A directional arrow indicating "open" is cast on top of the nut. All square operating nuts have a standard 2" square which facilitates opening and closing the valve with a square socket wrench as used by the Water Works. Material: Cast Iron ASTM A126 Class B. Field retrofit is standard. Some factory installed versions are available.



Position Indicator

For non-rising stem (2"-12") metal seated, (not resilient wedge,) iron body gate valves. Indicates whether it is open, partly open or closed by the position of the needle which moves as the valve is operated. Field installed.
Ordering Information: Specify size and figure number of the valve to be fitted.

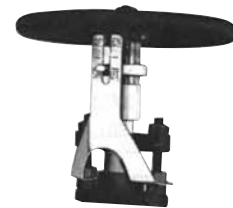

Adjustable Sprocket

The Adjustable Sprocket Rim will provide for remote operation of gate, globe and angle valves in high, normally out-of-reach locations. Attaches to valve wheel for instant valve open/close response. Sprocket rim made from cast iron, chain guide is malleable iron. When ordering, specify either the sprocket and chain number, or the NIBCO® valve figure number and size. The chain length must also be specified.

Size	Diameter of Sprocket Wheel (In.)	Weight (Lbs.)	O.D. of Valve Wheels Rim Will Fit	Chain Size	Chain Weight per 100' (Lbs.)
0	4.00	2	2-4	2	10.00
1	5.88	4	4 1/8-5 7/8	1/0	17.50
1 1/2	7.50	5	6-7 1/2	1/0	17.50
2	9.00	8	7 3/4-9	1/0	17.50
2 1/2	12.50	15	9 1/4-12 1/2	4/0	30.00
3	15.50	21	12 3/4-15 1/2	4/0	30.00
3 1/2	19.00	25	15 3/4-19	4/0	30.00
4	22.00	34	19 1/4-22	5/0	35.00
4 1/2	26.00	38	22 1/4-26	5/0	35.00
5	30.00	46	26 1/4-30	5/0	35.00

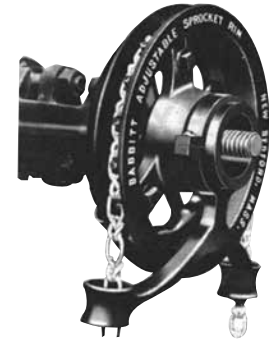

Hammer-Blow Sprocket

The Adjustable Hammer-Blow Sprocket Rim is for use with hard-to-operate gate, globe and angle valves in overhead locations. The Hammer-Blow plate and rim are made of tough, shock resistant ductile iron to withstand heavy, valve releasing impact. The chain guide is malleable iron. When ordering, specify the sprocket number, chain number and length, or the NIBCO valve figure number, size and the chain length.

Ductile Rim Guide with Hammer Blow Complete	Diameter of Sprocket Wheel (In.)	Weight (Lbs.)	Diameter of Valve Wheels Rim Will Fit	Chain Size	Chain Weight per 100' (Lbs.)
2	9.00	13	7 3/4-9	1/0	17.50
2 1/2	12.50	22	9 1/4-12 1/2	4/0	30.00
3	15.50	30	12 3/4-15 1/2	4/0	30.00
3 1/2	19.00	35	15 3/4-19	4/0	30.00
4	22.00	55	19 1/4-22	5/0	35.00
4 1/2	26.00	78	22 1/4-26	5/0	35.00
5	30.00	78	26 1/4-30	5/0	35.00

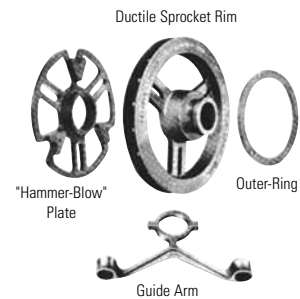

Sprocket Rim Selection Guide

	#1 1/2	#2	#2 1/2	#3	#3 1/2	#4	#4 1/2	#5
Fig. F-617-0 Size Valve Rim will fit		2, 2 1/2, 3	4, 5, 6	8	10, 12		14, 16, 18	20, 24
Fig. F-619 Size Valve Rim will fit	2, 2 1/2	3	4, 5, 6	8	10, 12		14, 16	
Fig. F-667-0 Size Valve Rim will fit		2, 2 1/2, 3	3, 4, 5		6, 8	10, 12		
Fig. F-669 Size Valve Rim will fit	2	2 1/2	3, 4, 5		6, 8, 10	12		

NIBCO INC. reserves the right to change materials, options and accessories without notice.

Visit our website for the most current information.

Iron Valve Options and Accessories

Stem Extensions

Stem Extension

Stem extensions are designed to permit remote operation of gate, globe or angle valves by providing an extension to the valve stem long enough to reach from the valve to the desired remote operating location.

The extension consists of a length of steel tube with a coupling on one end to attach to the valve, and a coupling on the other end to attach to a handwheel or some other type of operating device.

The stem extension is made to accept the handwheel from the valve to which it is being attached. Therefore, Extensions are not supplied with a handwheel unless it is special ordered.

Orders or inquiries for stem extensions to be attached to a NIBCO® valve must include the dimension from the center line of the valve waterway to the top of the handwheel. This dimension is the "A" distance as shown below. Please specify separately coupling sets for iron valve extensions.

Adequate support must be provided for long stem extensions exceeding 12 ft. of "A" dimension. This support should be rigid and of sufficient strength to prevent "wind-up," deflection or transfer of abnormal loads to the valve. This is a custom-built requirement provided by the customer.

Minimum "A" dimensions:

Rising Stem Valve

Valve Size	"A"	
	In.	mm.
2"	21.00	533
2½"	21.50	546
3"	23.50	597
4"	28.00	711
5"	31.00	787
6"	35.00	889
8"	45.00	1,143
10"	53.50	1,359
12"	63.00	1,600

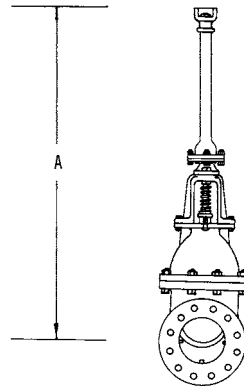

Non-Rising Stem Valve

Valve Size	"A"	
	In.	mm.
2"	19.56	497
2½"	21.06	535
3"	21.94	557
4"	24.25	616
5"	25.50	648
6"	29.50	749
8"	35.06	891
10"	38.88	988
12"	44.56	1,132

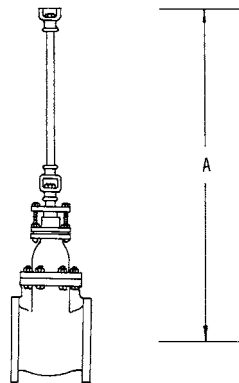

NIBCO INC. reserves the right to change materials, options and accessories without notice.

Visit our website for the most current information.

Iron Valve Options and Accessories

Floor Stands

Floor Stands

Floor stands are designed for operating gate, globe and angle valves that are installed in inaccessible places under a floor. For your convenience, they are available in two heights (20" and 32"). They are also available with an indicator so the position of the disc (wedge) can be read at a glance.

Floor Stand Base
Template

9" outside diameter
7½" bolt circle diameter
¾" hole diameter

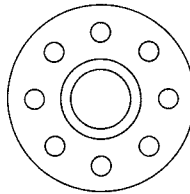

Without
Indicator

When ordering a floor stand – the dimension from the centerline of the valve waterway to the top of the floor must be furnished. This dimension is the "A" dimension pictured below. The NIBCO valve figure number and size must also be furnished and specify valve stem coupling for use with floor stand. Nothing extra is needed, except the floor mounting bolts which will vary depending on the floor construction.

Minimum "A" dimensions:

Rising Stem Valve

Valve Size	"A"	
	In.	mm.
2"	28.50	724
2½"	29.00	737
3"	31.00	787
4"	36.00	914
5"	39.00	991
6"	43.00	1,092
8"	53.00	1,346
10"	60.50	1,537
12"	70.00	1,778

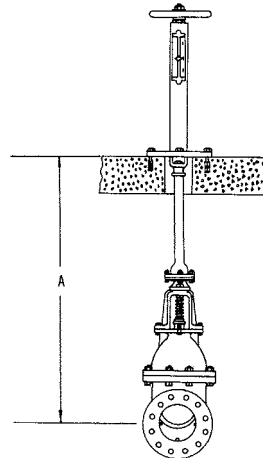

With
Indicator

Non-Rising Stem Valve

Valve Size	"A"	
	In.	mm.
2"	26.56	675
2½"	28.06	713
3"	28.75	730
4"	31.19	792
5"	32.44	824
6"	36.31	922
8"	42.69	1,084
10"	45.88	1,165
12"	52.06	1,322

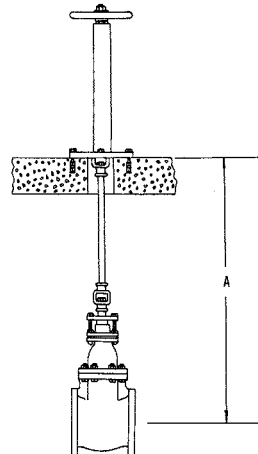

NIBCO INC. reserves the right to change materials, options and accessories without notice.

Visit our website for the most current information.

Iron Valve Options and Accessories

Tapping, Boss Locations, By-Passes*

Boss Locations

All NIBCO® iron valves are available with tapping for drain and special tapping. Boss locations and symbols and tapping procedures are in accordance with MSS By-Pass and Drain Connection Standard SP-45. All tapings are plugged at no extra charge. When Bosses are ordered tapped, the standard size of tapping is in accordance with the following table taken from MSS Specification SP-45, table 1.

Size of valve (In.)	2	2½	3	4	5	6	8	10	12	14	16	18	20	24
Size of Drain Tapping (In.)														
Series A (steam)	½	½	½	½	¾	¾	¾	1	1	1	1	1	1	1

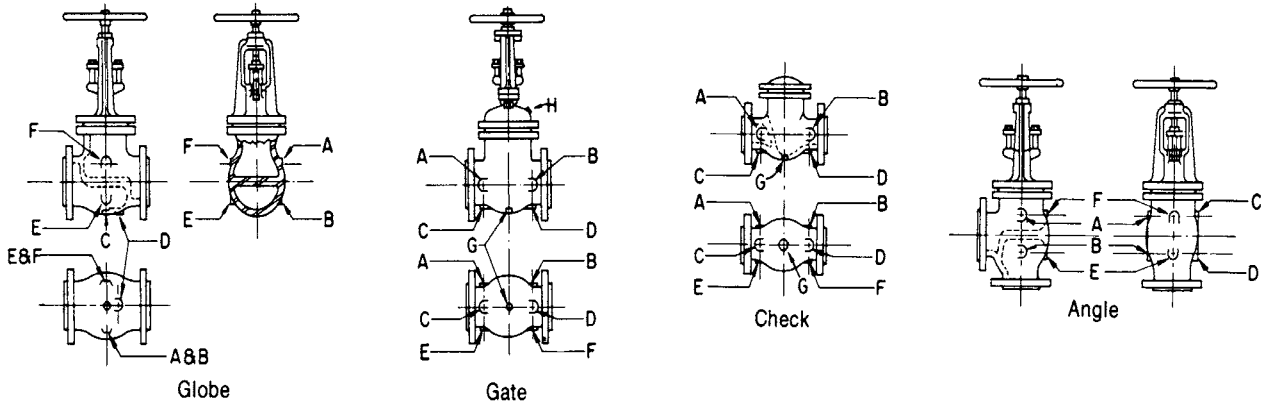

By-Passes*

A By-Pass can be used to equalize pressure at inlet and outlet before opening main valve; facilitates easy valve operation. Can also be used for preheating outlet lines and eliminate damage from too fast expansion. The built up type By-Pass is available on all NIBCO iron valves and is attached in accordance with MSS By-Pass and Drain Connection Standard SP-45. The By-Pass valve used on standard iron valves is a globe valve. Specify by adding (Z) to Fig. No, i.e. F-000-Z.

Main Valve Size (In.)	4	5	6	8	10	12	14	16	18	20	24
By-Pass Valve Size (In.)	½	¾	¾	¾	1	1	1	1	1	1	1

Sizes of By-Pass valves on NIBCO® Iron Gate, Globe, Angle and regular Swing Check Valves conform to MSS Specification SP-45, Table II, Series A for steam service.

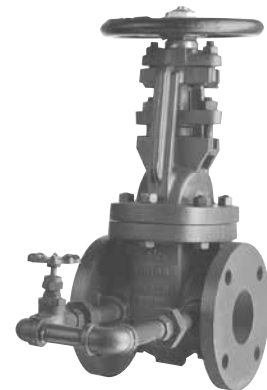

NIBCO INC. reserves the right to change materials, options and accessories without notice.

*By-Pass not available on F607-OTS

Visit our website for the most current information.

Iron Check Valve Options and Accessories

Lever and Weight/Spring (factory installed only)

Iron Body Swing Check Valves are available with Outside Lever and Weight or Lever and Spring

The lever and weight arrangement is used to maintain exterior control over disc movement. It is possible to assist the disc to close rapidly where quick action is necessary to avoid a sudden reversal of flow or set the lever and weight at any position to get desired operating performance.

Illustrated below are some commonly accepted positions of the lever and weight.

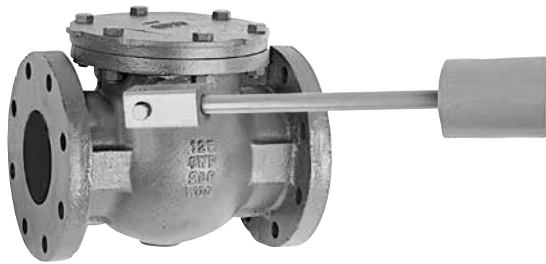

Lever and weight mounted to assist the disc in closing.

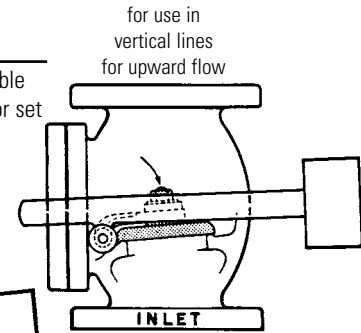
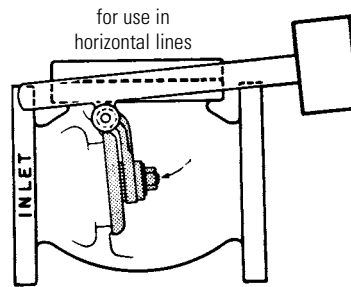

The lever and weight is mounted on the right side of the valve when facing the inlet. Available on Figure no. F-918 in sizes 2½"–12".

Lever and spring provides more positive control in closing the disc. Tension of the spring may be adjusted to control the pressure against the disc.

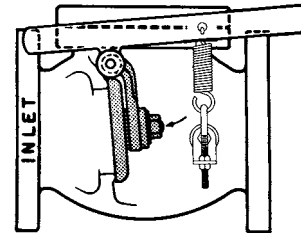

Fig. No. F-918-BL&S

Silicone lubricant usage in iron valves at the Blytheville, Arkansas, Plant

Multi-turn Iron Valves: Gate, Globe, Angle and Check

Of the valves that are produced at the Blytheville plant, the check valve is the only type that uses silicone during assembly. The silicone used is in the form of grease, and is applied to the seat.

NOTE: Valves that are assembled and tested without silicone lubricants in this plant have a potential exposure to air-borne silicone as well as during shipping after they leave the plant. Therefore, NIBCO cannot certify valves produced in the Blytheville plant to be 100% silicone free.

Special Ordered Check Valves:

We will, upon request, assemble check valves that are described as "Assembled-Dry". These valves are assembled **NOT** using the silicone grease.

NIBCO® Check Valves may be installed in both horizontal and vertical lines with upward flow or in any intermediate position. They will operate satisfactorily in a declining plane (no more than 15°).

WARNING: Do not use for reciprocating air compressor service.

NIBCO INC. reserves the right to change materials, options and accessories without notice.

Visit our website for the most current information.

Iron Check Valve Options and Accessories

Lever and Weight/Spring Parts • Gear Operators

(factory installed only)

Parts for Iron Body Swing Check Valves with Outside Lever and Weight or Lever and Spring

Parts for Lever and Weight (F-918-BL&W)

			Qty.
*1	Hanger and Spindle Key	Steel	1
*2	Hanger Pin	Brass ASTM B16	1
*3	Hanger	Ductile Iron	1
*4	Pack Nut	Brass	1
*5	Coupling	Steel	1
*6	Coupling Set Screw	Steel	2
7	Lever	Steel	1
8	Weight	Steel	1
9	Weight Set Screw	Steel	2
*10	Pack Gland	Zinc-Plated Powdered Iron	1
*11	Packing Rope	Non-Asbestos Fibers	1
*12	Stuffing Box	Brass ASTM B16	1
*13	Coupling and Lever Spring Pin	Steel	1

*Parts common to both F-918-BL&W and F-918-BL&S.

Parts for Lever and Spring (F-918-BL&S) (not pictured)

			Qty.
	Bracket Spacer	Steel 1020	1
	Bracket	Steel	1
	Bracket Bolt	Steel	2
	Eye Bolt	Steel	1
	Eye Bolt Nut	Steel	2
	Hanger and Spindle Key	Steel	1
	Lever	Steel	1
	Spring	Steel	1

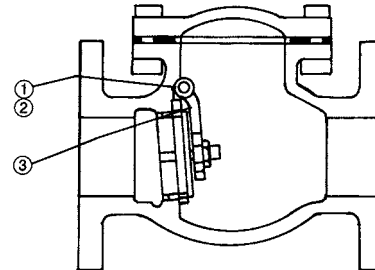
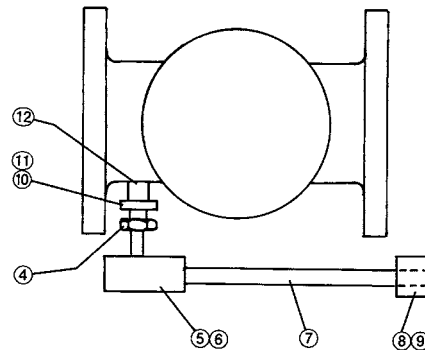

Gear Operators

Gearing is applied to valves to provide ease of operation.

Bevel Gears are the most versatile in that they have good efficiency.

Gears are weatherproofed and Babbitt® sprockets may be applied.

When ordering gear operators, always provide the following information:

1. Valve size
2. Figure number
3. Pressure of media
4. Temperature of media

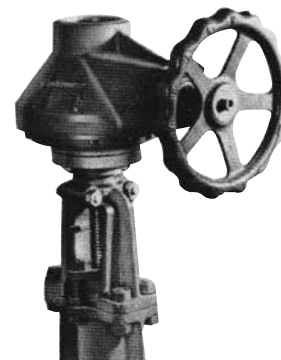

NIBCO INC. reserves the right to change materials, options and accessories without notice.

Visit our website for the most current information.

Engineering Data Index

Valve Terms and Piping Symbols	105
Properties of Valve Materials	106-109
Flow Data Cv Values for Valves	110-111
Reference Specifications	112
Marine Applications	113
Temperature Limits of Materials	114
Valve Installation Tips	115
Flange Dimensions	116-117
Steam Tables	118
Bronze Value Figure Number Comparisons	119
Iron Valve Figure Number Comparisons	120
Warranty	122

Chemical Compatibility

Please consult the most current edition of the NIBCO Chem-Guide for recommendations regarding chemical compatibility of material exposure to specific media and media-treatment additives. The NIBCO Chem-Guide is a general guide on the topic of chemical compatibility and is by no means an exhaustive resource on the subject. Ultimately, proper material selection is the responsibility of the installer and/or end-user, taking into account all aspects of a system's design and intended use.

Galvanic Potential in Piping Systems

Galvanic corrosion or dissimilar metal corrosion is an electrochemical process that is created through the electrical interaction of two different metals under the influence of a conductive media (i.e. an electrolyte). An electrolytic cell, much like a battery, is generated by these dissimilar metals using water as the electrolyte. The electrical charge, developed within the electrolytic cell, drives a preferential attack on the more electrically active metal with the water acting as the recipient of the discarded metal ions. Such galvanic attack is often encountered in service where iron or steel components are installed, and later corrode, in a largely copper piping system. Please consult NIBCO Technical Bulletin NTB-0714-01 Dielectric Products Relative to Electrolysis and Galvanic Corrosion.

Valve Terms and Piping Symbols

Common industry terms and abbreviations

AC	Alternating Current	EXP VLV	Expansion Valve	PSIA	Pounds Per Square Inch Absolute
ALL IRON	All-Iron Construction	F	Degree Fahrenheit	PSIG	Pounds Per Square Inch Gage
AMER STD	American Standard	FF	Flat Face	RECIRC	Recirculate(d)
AMS	Aeronautical Material Specifications of the Society of Automotive Engineers	FxF	Face to Face	RF	Raised Face
APPROX	Approximate	FLG	Flanged End	RPM	Revolutions per Minute
ASME	American Society of Mechanical Engineers	FM	Indicates product has been approved by Factory Mutual Laboratories	RS	Rising Stem
ASTM	American Society of Testing Materials	F/S	Factor of Safety	S.A.E.	Society of Automotive Engineers
ATM	Atmosphere	FSPS	Female Standard Pipe Size	SB	Screw-in Bonnet
BB	Bolted Bonnet	FT LB	Foot Pound	SE	Screwed (Threaded) End
BLR	Boiler	GPH	Gallons Per Hour	SJ	Solder Joint
B/M	Bill of Material	GPM	Gallons Per Minute	SPEC	Specification
BTU	British Thermal Unit(s)	IBBM	Iron Body, Bronze Mounted	STD	Standard
C	Degree Centigrade	IN LB	Inch-pound	SWP	Steam Working Pressure
CxC	Copper to Copper	IPS	Iron Pipe Size	TEMP	Temperature
CDA	Copper Development Association	MSS	Manufacturers Standardization Society of the Valve and Fitting Industry	TRIM	Term designating certain valve parts such as discs, seat rings, stems, and repacking seat bushings
COND	Condenser	NEC	National Electrical Code	UB	Union Bonnet
COP	Copper	NPT	American Standard Taper Pipe Thread	UL	Indicates product has been approved by Underwriter's Laboratories, Inc.
CSA	Canadian Standards Association	NRS	Non-Rising Stem	VAC	Vacuum
CV	Check Valve	OD	Outside Diameter	VOL	Volume
CWP	Cold Working Pressure	OS&Y	Outside Screw and Yoke	WOG	Water, Oil, Gas Working Pressure
CYL	Cylinder	PNEU	Pneumatic	WWP	Water Working Pressure
DC	Direct Current	PRESS	Pressure		
DD	Double Disc	PRV	Pressure Reducing Valve		
		PSI	Pounds Per Square Inch		

Piping Symbols

	Flanged	Threaded	Bell & Spigot	Welded	Soldered		Flanged	Threaded	Bell & Spigot	Welded	Soldered
1. Angle Valve						8. Globe Valve					
1.1 Check						8.1					
1.4 Globe (elevation)						8.2 Angle Globe	Same as Symbols 1.4 & 1.5				
1.5 Globe (plan)						8.3 Hose Globe	Same as Symbol 9.3				
1.6 Hose Angle	Same as Symbol 9.1					8.4 Motor-Operated					
2. Automatic Valve						9. Hose Valve					
2.1 By-Pass						9.1 Angle					
2.2 Governor-Operated						9.2 Gate					
2.3 Reducing						9.3 Globe					
3. Check Valve						10. Lockshield Valve					
3.1 Angle Check	Same as symbol 1.1					11. Quick-Opening Valve					
3.2 (straight way)						12. Safety Valve					
4. Cock						13. Stop Valve	Same as Symbol 7.1				
5. Diaphragm Valve						14. Tee					
6. Float Valve						14.7 Side Outlet (outlet down)					
7. Gate Valve						14.8 Side Outlet (outlet up)					
7*.1						15. Union					
7.4 Motor-Operated											

*Also used for general STOP VALVE symbol when amplified by specification.

Visit our website for the most current information.

Properties of Valve Materials

ALLOY	ASTM NO.	OTHER ALLOY DESIGNATION	NOMINAL OR MAXIMUM CHEMICAL COMPOSITION									
			CARBON		CHROME	COBALT	COPPER	IRON	LEAD	MANGA-NESE	MOLYB-DENUM	
			AL	C	Cr	Co	Cu	Fe	Pb	Mn	Mo	
Commercial Aluminum 380	SC 84 A (modified)	UNS A38000	87.0					1.0	1.3		.35	
Free Cutting Brass	B 16	UNS C36000						61.5		3.0		
Navy "M" (Steam Bronze)	B 61	UNS C92200	.005					88.0	.25	1.5		
Composition Bronze (Ounce Metal)	B 62	UNS C83600	.005					85.0	.30	5.0		
Copper-Silicon Alloy B	B 98/B 99	UNS C65100						96.0	.8	.05	.7	
Forging Brass	B 124	UNS C37700						60.0	.3	2.0		
Forging Brass	B 283	UNS C37700						58.0	.3	2.5		
Brass Wire (Red Brass)	B 134	UNS C23000						85.0	.05	.05		
Leaded Red Brass	B 140	UNS C31400						89.0	.10	1.9		
Aluminum Bronze (Cast)	B 148	UNS C95400	11.0					85.0	4.0			
Aluminum Bronze (Rod)	B 150	UNS C64200	7.0					91.0	.30	.05	.10	
Silicon Red Brass	B 371	UNS C69400						81.5	.20	.30		
Leaded Semi-Red Brass	B584	UNS C84400	.005					81.0	.40	7.0		
Leaded Red Brass		UNS C84500	.005					78.0	.40	7.0		
Leaded Nickel Bronze	B584	UNS C97600						64.0		4.0		
Copper (Wrot)	B 75	UNS C12200						99.9				
Gray Iron	A 126	Class B										
3% Ni Gray Iron	A 126 (modified)	Class B										
Austenitic Gray Iron (Ni-Resist)	A 436	Type 2		3.00	2.0			.5			1.0	
Ductile Iron (Ferritic)	A 395			3.20								
Austenitic Ductile Iron (Ductile)	A 536 65-45-12											
(Ductile)	A 536 80-55-06											
(Ni-Resist)	A 439 D2C			2.9	.5					2.4	1.0	

Visit our website for the most current information.

NOMINAL OR MAXIMUM CHEMICAL COMPOSITION							NOMINAL PHYSICAL PROPERTIES				
NICKEL Ni	PHOS P	SILICON Si	SULFUR S	TIN Sn	TITAN- IUM Ti	TUNG- STEN W	ZINC Zn	TENSILE STRENGTH Psi	YIELD STRENGTH Psi	% ELONGATION	HARDNESS
.50		12.0		.15			.50	42,000	19,000	3.5	
							35.5	50,000	20,000	15	75 HRB
1.0	.05	.005	.05	6.0			4.5	34,000	16,000	22	65 HB *500 kg
1.0	.05	.005	.08	5.0			5.0	30,000	14,000	20	60 HB 500 kg
		1.6					1.5	86,000**	20,000	11	65 HRB
							38.0	52,000	20,000	45	80 HRB
							38.0	52,000	20,000	45	78 HRB
							15.0	56,000			60 HRB
.7							9.1	50,000	30,000	7	60 HRB
								75,000	30,000	12	170 HB *3000 kg
.25		2.0		.20			.50	90,000	45,000	9	80 HRB
		4.0					14.5	80,000	40,000	15	85 HRB
	.02	.005	.08	3.0			9.0	29,000	13,000	18	55 HB *500 kg
1.0	.02	.005	.08	3.0			12.0	29,000	13,000	16	55 HB *500 kg
20.0				4.0			8.0	40,000	17,000	10	80 HB
	.02							36,000	30,000	25	45 T
	.75		.15					31,000			195 HB
3.00	.75		.15					31,000			195 HB
20.0		2.0	.12					25,000			118 HB
	.08	2.50						60,000	40,000	18	167 HB
	.08	2.50						65,000	45,000	12	160 HB
	.08	2.50						80,000	55,000	6	160 HB
24.0	.08	3.0						58,000	28,000	20	146 HB

*Load Applied During Testing
**Allowable Range is 75,000 to 95,000

Visit our website for the most current information.

Properties of Valve Materials

ALLOY	ASTM NO.	OTHER ALLOY DESIGNATION	NOMINAL OR MAXIMUM CHEMICAL COMPOSITION									
			CARBON		CHROME	COBALT	COPPER	IRON	LEAD	MANGA-NESE	MOLYB-DENUM	
			AL	C	Cr	Co	Cu	Fe	Pb	Mn	Mo	
Wrot 304	A 167 304	UNS S30400	.08		19						2	
Cast 316	A 351 CF8M	UNS S31600	.08		20						1.5	2.5
Cast 316	A 743 CF16F		.16		20						1.5	1.5
Cast 316	A 743 CF8M		.08		20						1.5	2.5
Stainless Steel												
Wrot 316	A 276 316	UNS S31600	.08		17						2	
Cast 410	A 217 CA 15		.15		13						1	2.5
Forged 410	A 182 F6A2		.15		13						1	
Wrot 410	A 276 410	UNS S41000	.15		13						1	
Wrot 416	A 582	UNS S41600	.15		13						1.25	
Wrot 420	A 276 420	UNS S42000	.15		13						1	
Cast Alloy 20	A 743 CN7M		.07		20			3.5			1.5	2.5
Wrot Alloy 20	B 473 20C63	UNS N08020	.07		20			3.5			2	2.5
Wrot 17-4PH	A 564 630	UNS S17400	.07		16			3.5			1	
Steels												
Forged Carbon Steel	A 105		.35								1	
Cast Carbon Steel	A 216 WCB		.3								1.1	
Cast Carbon Steel	A 216 WCC		.25								1.2	
1¼ Cast Cr. Moly Steel	A 217 WC6		.2		1.2						.7	.55
Cast Cr. Moly Steel	A 217 C5		.2		5						.55	.55
Cast Low Carbon Steel	A 352 LCB		.3								1.0	
Nickel-Low Carbon Steel	A 352 LC2		.25								.65	
B-7 Alloy Steel Studs	A 193 B7		.4		1						.85	.2
304 SS Nuts	A 194 GR8		.08		19						2	
2-H Alloy Steel Nuts	A 194 2H		.4									
Reg. Steel Bolting	A 307 Gr. A		.29								1.2	
Trim Steels												
Steel Bolting	A 449		.4								.6	
304SS Bolting	A 493 304	UNS S30400	.08		19						2	
Eyebolts	A 489		.48								1.0	
Gland Nuts	A 563 Gr. A		.37		.55			.35			1.0	
H/W Nuts	A 108 1020	UNS G10200	.20								.45	
Swing Bolt Pin	A 108 1212	UNS G12120	.13								.85	
Yoke Bushing Caps	A108 12L14		.15							.25	1.0	
Seat Ring Base	A 519 1026		.25								.75	
Monel H.F.												
(Trademark Materials like, Stellite 6*, Stody 6, and Wallex 6)		AWS 5.13	1.25		29		55		2.5			
Cast Monel		QQ-N-288-E	.5	.3				30	3.5		1.5	
Wrought Monel (K-500)		QQ-N-286-C1B	3.0	.1				24	2.0		1.5	

*Trademark by Cabot Corp.

Visit our website for the most current information.

NOMINAL OR MAXIMUM CHEMICAL COMPOSITION								NOMINAL PHYSICAL PROPERTIES			
NICKEL	PHOS	SILICON	SULFUR	TIN	TITANIUM	TUNGSTEN	ZINC	TENSILE	YIELD	%	HARDNESS
Ni	P	Si	S	Sn	Ti	W	Zn	STRENGTH	STRENGTH	ELONGATION	
								Psi	Psi		
9	.045	1.0	.03					75,000	30,000	40	202 HB
11	.04	2.0	.04					70,000	30,000	25	
11	.04	2.0	.04					70,000	30,000	30	
12	.045	1.0	.03					75,000	30,000	30	
12	.045	1.0	.03					75,000	30,000	30	
1	.04	1.5	.04					90,000	65,000	18	
	.04	1.0	.03					85,000	55,000	18	200/225 HB
.5	.04	1.0	.03					100,000	80,000	15	
	.06	1.0	.15					114,000	95,000	17	235 HB
	.04	1.0	.03								250/450 HB
28	.04	1.5	.04					62,000	25,000	35	
35	.045	1.0	.035					85,000	35,000	30	
4	.04	1.0	.03					115,000	75,000	18	255 HB
	.04	.035	.05					70,000	36,000	22	187 HB
	.04	.6	.045					70,000	36,000	22	
	.04	.6	.04					70,000	40,000	22	
	.04	.06	.045								
	.04	.75	.045								
	.04	.6	.045					65,000	35,000	24	
2.5	.04	.6	.045					70,000	40,000	24	
	.035	.25	.04					125,000	105,000	16	
9	.045	1.0	.03								126/300 HB
	.04		.05								250/300 HB
	.04		.15					60,000		18	121/241 HB
	.04		.05					120,000	92,000	14	
9	.045	1.0	.03					90,000			
	.04	.25	.05					75,000	30,000	30	
.35	.04	.2	.05								
	.04		.05								120/300 HB
	.10		.20								
	.07		.3					55,000	35,000	25	
	.04		.05								
3						5		105,000		10	350 HB
60		1.5						65,000	32,500	25	125/150 HB
67		.5	.01		.5			135,000	95,000	20	255 HB

Visit our website for the most current information.

Flow Data

C_v Values for Valves

Liquid Flow:

$$Q = C_v \sqrt{\frac{\Delta P}{S}} \quad \text{or} \quad \Delta P = S \left(\frac{Q}{C_v} \right)^2$$

where... Q = flow rate (gallons per minute)
 ΔP = pressure drop across valve (psi)
 S = specific gravity of media

This equation is good for turbulent flow and for liquids with viscosities near that of water.
 (C_v is defined as the flow in GPM that a valve will carry with a pressure drop of 1.0 psi when the media is water at 60°F.) (The specific gravity of water is 1 (one).)

Valve Size																
Size (mm.)	4	8	10	15	20	25	32	40	50	65	80	90	100	125	150	200
Size (In.)	1/8	1/4	3/8	1/2	3/4	1	1 1/4	1 1/2	2	2 1/2	3	3 1/2	4	5	6	8
GATES																
S/T-29	0.5	2	4.9	9.1	22	40	65	95	175							
S/T-111, 113, 131, 133 134, 136, 154, 174, 176	—	5.6	10.7	17.6	32	54	97	135	230	337	536	710	960	1,525	2,250	
T/F-617, 619, 667, 669, 607, 609 F-637, 639									215	335	510	710	945	1,525	2,250	4,150
GLOBES																
S/T-211, 235, 256 275-Y	0.61	1.16	2.2	3.64	6.65	11.1	20	28	48	70	111	—	198			
T-275-B	—	1.16	2.21	3.64	6.65	11.1	20	28	48	70	111					
F-718, F-738									45	70	105	—	195	315	465	860
CHECKS																
S/T-413, 433, 473 (Swing)	—	1.3	2.5	4.8	14.3	24	43	60	102	150	238	315	435	675	1,000	
S/T-480 (Poppet)	—	—	3.7	6.86	16.3	30	49	72	130							
F-908 (Swing)										243	356	—	665	1,073	1,584	2,937
T/F-918, 968, 938 (Swing)									137	221	327	—	605	975	1,440	2,670
KW-900-W									60	105	184	—	354	577	801	1,500
F-910, 960 (Poppet)										110	155	—	278	431	625	1,115
W-910, 960 (Poppet)									66	88	130	—	228	350	520	900
G-920-W									77	129	209	—	358	573	898	1,740
W-920-W									76	161	224	—	400	648	1060	1,890
BALL																
F-510, 530	—	—	—	11	25	45	—	137	217	—	482	—	790	—	1,144	2,164
F-515, 535	—	—	—	25	50	85	—	259	440	840	1,400	—	2,350	—	5,200	10,200
F-565	—	—	—	—	—	75	—	235	400	—	1,180	—	2,040	—	—	—
T-560-BR/CS/S6	—	4	4	5	12	22	35	52	95	—	—					
T-570	—	—	—	7	12	25	38	52	95	—	—					
T/S-580	—	—	—	5.8	13.9	27	44	64	100	—	—					
T/S-580-70	—	—	—	—	—	—	38.5	76	101.4	183	390					
T/S-585-70	—	4.2	6.2	15.3	30.4	48.8	103	143	245	—	—					
TM-585-70-66	—	—	—	15.3	30.4	48.8	103	143	245	—	—					
AT-585-70-66	—	—	—	—	—	—	—	—	—	183	—					
T-580-70-W3	—	—	—	—	—	—	21.6	38	48.5	—	—					
T/S-585-70-W3	—	—	—	6	12	19.5	—	—	—	—	—					
T-580 (CS-S6)	—	6	12	15	23	36	44	64	114	—	—					
T/S-590-Y	—	—	—	—	—	—	44	64	100	183	390					
T/S-595-Y	—	5.9	11.4	18.7	34	57	103	143	245	310	—					
TM/KM-595 (CS-S6)	—	6	12	19	37	64	103	143	245	—	—					
T/K-595 (CS-S6)	—	6	12	19	37	64	103	143	245	—	—					
BUTTERFLY																
LD/WD-1000, 2000, 3000									166	247	340	—	660	1,080	1,613	3,759
GD-4765, 4775 FC-2700, FD-5700									145	195	290	—	600	930	1,600	3,450

NOTE: Flow data for angle valves use globe Cv times 1.25:
 Bronze Angles — 311, 335, 375, 376-AP
 Iron Angles — 818, 869, 831

Visit our website for the most current information.

Gas Flow:

$$Q = 1360 C_v \sqrt{\frac{\Delta P \times P_1}{S T}}$$

- where . . . Q = gas flow (SCFH—std. cu. ft/hr)
- S = specific gravity of gas (air = 1.0)
- T = temp—degrees Rankine (°F + 460)
- ΔP = pressure drop across valve (psi)
- P₁ = upstream pressure (psia) absolute

NOTE: ΔP must be less than .5 P₁. (Flow is critical when ΔP is greater than .5 P₁.)

									Throttling Factors											
									For throttling use with disc partially open. Multiply C _v by factor.											
									NOTE: Gate Valves are not throttled.											
250	300	350	400	450	500	600	750	900	0	10	20	30	40	50	60	70	80	90	100	
10	12	14	16	18	20	24	30	36												
6,700	9,925	13,800	18,375	23,600	29,600	43,570														
									0	0.35	0.65	0.90	0.93	0.96	0.98	0.99	1.00	1.00	1.00	
									0	0.030	0.035	0.06	0.10	0.16	0.24	0.32	0.47	0.68	1.00	
1,390									0	0.35	0.65	0.90	0.93	0.96	0.98	0.99	1.00	1.00	1.00	
									WARNING											
									The Fluid Flow factors contained herein are calculated values. They are, therefore, approximations and cannot be used for highly critical flow or pressure drop calculations. For very precise flow measurements, tests must be conducted on any valve mentioned within this catalog. Throttling of ball valves is not recommended when valves are less than 45° open.											
4,730	6,985																			
4,300	6,350																			
2,357	3,742																			
1,770	2,500	3400	4400	5600	6900	10000	15400	22400												
1,450																				
3,180	4,950																			
3,340	5,270	5,700	7,200	9,400	12,000	18,500	33,000	50,000												
									0°	10°	20°	30°	40°	45°	50°	60°	70°	80°	90°	
3,507	5,516								0	0.01	0.05	0.16	0.3	0.37	0.45	0.58	0.71	0.87	1	
14,400	25,300								0	0.01	0.05	0.16	0.3	0.37	0.45	0.58	0.71	0.87	1	
									0	0.01	0.05	0.16	0.3	0.37	0.45	0.58	0.71	0.87	1	
									0	0.01	0.05	0.16	0.3	0.37	0.45	0.58	0.71	0.87	1	
									0	0.01	0.05	0.16	0.3	0.37	0.45	0.58	0.71	0.87	1	
									0	0.01	0.05	0.16	0.3	0.37	0.45	0.58	0.71	0.87	1	
									0	0.01	0.05	0.16	0.3	0.37	0.45	0.58	0.71	0.87	1	
									0	0.01	0.05	0.16	0.3	0.37	0.45	0.58	0.71	0.87	1	
									0	0.01	0.05	0.16	0.3	0.37	0.45	0.58	0.71	0.87	1	
									0	0.01	0.05	0.16	0.3	0.37	0.45	0.58	0.71	0.87	1	
									0	0.01	0.05	0.16	0.3	0.37	0.45	0.58	0.71	0.87	1	
									0	0.01	0.05	0.16	0.3	0.37	0.45	0.58	0.71	0.87	1	
									0	0.01	0.05	0.16	0.3	0.37	0.45	0.58	0.71	0.87	1	
5,300	7,969	11,917	16,383	21,705	27,908	43,116	63,328	86,375	0	0.03	0.06	0.12	0.18	0.22	0.27	0.4	0.56	0.8	1	
5,800	8,950								0	0.03	0.06	0.12	0.18	0.22	0.27	0.4	0.56	0.8	1	

Visit our website for the most current information.

Reference Specifications

NIBCO® valves are designed and manufactured to give maximum performance on recommended service at the lowest possible initial and upkeep cost. They also meet or exceed the following specifications developed through years of experience, research and many thousands of laboratory tests by technical researchers, producers, consumers, government agencies and universities.

NOTE: WW-V-51, WW-V-54, WW-V-58 have been cancelled and replaced by the corresponding MSS Specifications.

BRONZE

- Federal Specification WW-V-51e Class A, Type I Covers 125 lb. S.W.P. Globe Valves (MSS SP-80).
- Federal Specification WW-V-51e Class A, Type II Covers 125 lb. S.W.P. Angle Valves (MSS SP-80).
- Federal Specification WW-V-51e Class A, Type IV Covers 125 lb. S.W.P. Swing Check Valves (MSS SP-80).
- Federal Specification WW-V-51e Class B, Type I Covers 150 lb. S.W.P. Globe Valves (MSS SP-80).
- Federal Specification WW-V-51e Class B, Type II Covers 150 lb. S.W.P. Angle Valves (MSS SP-80).
- Federal Specification WW-V-51e Class B, Type IV Covers 150 lb. S.W.P. Swing Check Valves (MSS SP-80).
- Federal Specification WW-V-51e Class C, Type I Covers 200 lb. S.W.P. Globe Valves (MSS SP-80).
- Federal Specification WW-V-54d Class A, Type I Covers 125 lb. S.W.P. Wedge Disc, Non-Rising Stem Gate Valves (MSS SP-80).
- Federal Specification WW-V-51e Class C, Type II Covers 200 lb. S.W.P. Angle Valves (MSS SP-80).
- Federal Specification WW-V-51e Class C, Type IV Covers 200 lb. S.W.P. Swing Check Valves (MSS SP-80).
- Federal Specification WW-V-54d Class A, Type II Covers 125 lb. S.W.P. Wedge Disc, Rising Stem, Inside Screw Gate Valves (MSS SP-80).
- Federal Specification WW-V-54d Class A, Type III Covers 125 lb. S.W.P. Double Disc, Rising Stem, Inside Screw Gate Valves (MSS SP-80).
- Federal Specification WW-V-54d Class B, Type I Covers 150 lb. S.W.P. Wedge Disc, Non-Rising Stem Gate Valves (MSS SP-80).
- Federal Specification WW-V-54d Class B, Type II Covers 150 lb. S.W.P. Wedge Disc, Rising Stem, Inside Screw Gate Valves (MSS SP-80).
- Federal Specification WW-V-54d Class B, Type III Covers 150 lb. S.W.P. Double Disc, Rising Stem, Inside Screw Gate Valves (MSS SP-80).
- Federal Specification WW-V-54d Class C, Type I Covers 200 lb. S.W.P. Wedge Disc, Non-Rising Stem Gate Valves (MSS SP-80).
- Federal Specification WW-V-54d Class C, Type II Covers 200 lb. S.W.P. Wedge Disc, Rising Stem, Inside Screw Gate Valves (MSS SP-80).
- Federal Specification WW-V-35b Covers 150 lb. S.W.P. Ball Valves.

IRON

- Federal Specification WW-V-58b Class 1, Type I Covers 125 lb. S.W.P. Wedge Disc, OS&Y, Screwed End, Cast Iron Gate Valves (MSS SP-70).
- Federal Specification WW-V-58b Class 2, Type I Covers 250 lb. S.W.P. Wedge Disc, OS&Y, Screwed End, Cast Iron Gate Valves (MSS SP-70).
- Federal Specification WW-V-58b Class 1, Type I Covers 125 lb. S.W.P. Non-Rising Stem, Inside Screw, Screwed End, Cast Iron Gate Valves (MSS SP-70).

- Federal Specification WW-V-58b Class 2, Type I Covers 250 lb. S.W.P. Non-Rising Stem, Inside Screw, Screwed End, Cast Iron Gate Valves (MSS SP-70).
- Federal Specification WW-V-58b Class 1, Type I Covers 125 lb. S.W.P. OS&Y, Flanged End, Cast Iron Gate Valves (MSS SP-70).
- Federal Specification WW-V-58b Class 2, Type I Covers 250 lb. S.W.P. OS&Y, Flanged End, Cast Iron Gate Valves (MSS SP-70).
- Federal Specification WW-V-58b Class 1, Type I Covers 125 lb. S.W.P. Non-Rising Stem, Inside Screw, Flanged End, Cast Iron Gate Valves (MSS SP-70).
- Federal Specification WW-V-58b Class 2, Type I Covers 250 lb. S.W.P. Non-Rising Stem, Inside Screw, Flanged End, Cast Iron Gate Valves (MSS SP-70).

STANDARDS—FOR INFORMATION PURPOSES ONLY

- MSS SP-25 Standard Marking System for Valves, Fittings, Flanges and Unions.
- MSS SP-45 Covers By-Pass and Drain Connections.
- MSS SP-67 Covers Butterfly Valves of the Single Flange Type (Lug Wafer).
- MSS SP-67 Covers Butterfly Valves of the Flangeless Type (Wafer).
- MSS SP-70 Covers Cast Iron Gate Valves, Flanged and Threaded Ends.
- MSS SP-71 Covers Cast Iron Swing Check Valves, Flanged and Threaded Ends.
- MSS SP-72 Covers Ball Valves with Flanged or Butt-Welding Ends for general service.
- MSS SP-80 Covers Bronze Gate, Globe, Angle and Check Valves.
- MSS SP-85 Covers Cast Iron Globe and Angle Valves, Flanged and Threaded Ends.
- MSS SP-110 Covers Ball Valves, Threaded, Socket-Welding, Solder Joint, Grooved and Flared Ends.
- ASME Standard B1.1—The Unified Screw Threads Standard that covers manufacturing tolerances of screw threads.
- ASME Standard B1.20.1—This standard controls NIBCO pipe threads.
- ASME Standard B2.4—This standard controls NIBCO hose coupling screw threads.
- ASME Standard B16.18—This standard controls NIBCO valve solder cups.
- ASME Standard B16.1—Covers cast iron pipe flanges and flanged fittings (Class 125 and 250).
- ASME Standard B16.10—Covers face-to-face and end-to-end dimensions of ferrous valves.
- MILITARY Standard MIL-V-18436—Applies to bronze and iron check valves sizes 1/2" thru 12".
- NIBCO Federal code No. is 12168. It has been assigned to NIBCO by the Defense Logistics Service Center, Battle Creek, Michigan. Used for coding NIBCO as spare parts for valves used on other equipment.

Marine Applications

CG190 **COAST GUARD**
Now called "CIMDTINST - M16714.3"
"Equipment Lists"
"Items approved, certified or accepted under Marine Inspection and Navigation Laws."
NIBCO Valves, Fittings and Flanges are listed in this document.

Code of Federal Regulations Title 46 Shipping Parts 41 to 69 The Code of Federal Regulations is a codification of the general and permanent rules published in the Federal Regulations by the Executive Departments and Agencies of the Federal Government.

This regulation is constantly revised to reference the latest ANSI, ASTM & MSS Standards to which NIBCO conforms to when building products.

APL, CID, NSN **NAVY**
"Department of the Navy"
"Navy Ships Parts Control Center"
Mechanicsburg, PA
The Department of the Navy, when using standard commodity type valves, assigns APL-CID numbers to each individual valve manufactured by a company. Valves of the same figure number, but of different size get different CID numbers.

The (APL) Allowance Parts List, (CID) Code Identification Numbers and (NSN) National Stock Numbers are used by the Navy in the Parts Control Center to order replacement valves or parts for valves that are installed on board United States Navy vessels.

When a Navy vessel is being built, the ship yard doing the construction must apply to the Parts Control Center for CID numbers on all valves before the Navy will accept delivery of the vessel.

On many NIBCO valves, the CID and NSN numbers have been assigned. Consult NIBCO for more information.

Rules for Building **AMERICAN BUREAU OF SHIPPING**
The American Bureau of Shipping states in Article 36.15.1; All valves are to be constructed and tested in accordance with a recognized standard, such as ANSI, MSS or other, acceptable to the Bureau. They are to bear the trademark of the manufacturer legibly stamped or cast on the exterior of the valve, as well as the pressure rating class for which the manufacturer guarantees the valve will meet the requirements of the standards.

The following iron gate, globe and check valves are approved by ABS for marine service: F-617, F-619, F-637, F-639, F-718, F-738, F-918, and F-938 series.

Manufacturers Federal Code: NIBCO - 12168

LLOYD'S REGISTER OF SHIPPING
NIBCO iron valves are approved by Lloyd's Register.

Certificate No. NOS 9603021

Temperature Limits of Materials

Rated Internal Working Pressures of Joints made with Copper Water Tube and Solder Type Fittings, PSI (Bar)

Solder or Brazing Alloy Used in Joints	Service Temperature ° F (° C)		Copper Water Tube K, L and M Nominal Sizes, In Inches (mm)					Saturated Steam LB (kg) All Sizes
			Water A					
			¼" to 1"	1¼" to 2"	2½" to 4"	5" to 8"	10" to 12"	
50-50 Tin-Lead ^{B, G}	100	(38)	200 (14)	175 (12)	150 (10)	135 (9)	100 (7)	15 ^D (6.8) ^D
	150	(66)	150 (19)	125 (8)	100 (7)	90 (6)	70 (4)	
	200	(93)	100 (9)	90 (6)	75 (5)	70 (40)	50 (3)	
	250	(121)	85 (6)	75 (5)	50 (3)	45 (3)	40 (2)	
95-5 Tin-Antimony ^C	100	(38)	635 (43)	560 (39)	375 (26)	340 (23)	150 (10)	15 ^D (6.8) ^D
	150	(66)	635 (43)	560 (39)	375 (26)	340 (23)	150 (10)	
	200	(93)	630 (43)	480 (33)	375 (26)	340 (23)	140 (10)	
	250	(121)	435 (30)	330 (23)	265 (18)	245 (16)	110 (7)	
Brazing Alloys, Melting at or above 1000° F (538°C)	100-150-200	(32-66-93)	H	H	H	H	H	120 ^E (54.4) ^E
	250 ^F	(121) ^F	H	H	H	H	H	
	350	(177)	H	H	H	H	H	

The values in the above table are based on data in the National Bureau of Standards publications, "Building Materials and Structures Reports" BMS 58 and BMS 83.

^AIncluding other non-corrosive liquids and gases.

^BASTM B 32, Alloy Grade Sn50.

^CASTM B 32, Alloy Grade Sb5.

^DThis pressure is determined by the temperature of saturated steam at 15 lb. (6.8 kg) pressure at 250°F (121°C).

^EThis pressure is determined by the temperature of saturated steam at 120 lb. (54.4 kg) pressure at 350°F (177°C).

^FFor service temperatures lower than 250°F (121°C), the solders as above may be used.

^GThe Safe Drinking Water Act Amendment of 1986 prohibits the use in potable water systems of any solder having a lead content in excess of 0.2%.

^HRated internal pressure is that of the tube being joined. While solders can be used, brazing alloys are recommended.

Pressure/Temperature Ratings for Threaded Bronze Pressure Rated Valves†

Press. Class	125 ^{2,3}	150 ³	200 ³	300 ³
Temperature	Thd.	Thd.	Thd.	Thd.
°F	°C	ASTM B 62	ASTM B 61	
-20 to 150	-28.8 to 65.5	200	300	400 600
200	93.3	185	270	375 560
250	121.1	170	240	350 525
300	148.8	155	210	325 490
350	176.6	140	180	300 450
400	204.4	—	—	275 410
406	207.7	125	150	— —
450	232.2	120 ¹	145 ¹	250 375
500	260.0	—	—	225 340
550	287.7	—	—	200 300

¹Some codes (i.e. ASME BPVC, SECTION 1) limit the rating temperatures of the indicated material to 406° F temperatures.

²Buna-N disc valves limited to 180° F temperatures.

³PTFE disc valves limited to 450° F temperatures.

⁴Solder end valves are limited by temperatures which affect the strength of the solder joint.

†Tables from MSS SP-80

Pressure/Temperature Ratings for NIBCO® Gray Iron and Ductile Iron Valves

¹ Temperature		Gray Iron				Ductile Iron	
		Class 125 200 WOG		Class 250 500 WOG		Class 150	
°F	°C	2"-12"	14"-24"	30"-48"	2"-12"	14"-24"	2"-12"
-20 to 100	-28.8 to 37.7	200	150	150	500	300	250
150	65.5	200	150	—	500	300	243
200	93.3	190	135	115	460	280	235
225	107.2	180	130	100	440	270	—
250	121.1	175	125	85	415	260	225
275	135.0	170	120	65	395	250	—
300	148.8	165	110	50	375	240	215
325	162.7	155	105	—	355	230	—
350	176.6	150	100	—	335	220	210
375	190.5	145	—	—	315	210	—
400	204.4	140	—	—	290	200	200
425	218.3	130	—	—	270	—	—
*450	232.2	125	—	—	250	—	185
500	260.0	—	—	—	—	—	170
550	287.7	—	—	—	—	—	155
600	315.5	—	—	—	—	—	140
650	343.3	—	—	—	—	—	125

The temperature shown for the corresponding rating shall be the metal temperature of the pressure retaining parts. It shall be assumed that the metal temperature will be the temperature of the contained fluid. Use of a pressure rating at a metal temperature other than that of the contained fluid shall be the responsibility of the user.

¹Buna-N Disc Valves limited to 180° F or EPDM Disc Valves limited to 250° F.

*Maximum temperature for bronze trim or PTFE

Valve Installation Tips

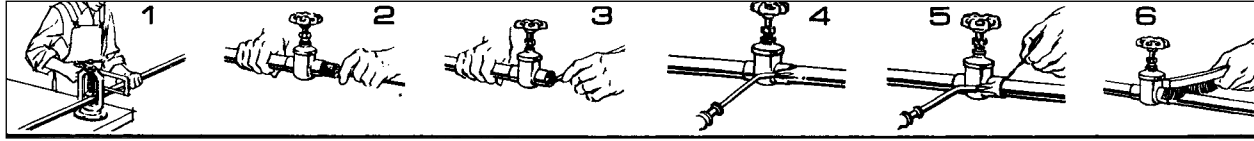

SOLDERING AND SILVER BRAZING

Analyze the application to determine which valve is best suited for installations, keeping in mind the service for which the valve is recommended. Before installing the correct valve, review the installation instructions to prevent damage to the valve and to assure its maximum efficiency.

1. Cut tube end square. Ream, burr and size.
2. Use sand cloth or steel wire brush to clean both ends to a bright metal finish. Steel wool is *not* recommended.
3. Apply flux to outside of tube and inside of solder cup. Surfaces to be joined must be completely covered. Use flux sparingly.
4. Be sure that valve is fully open. Apply heat to tube first. Transfer as much heat as possible through tube into valve. Avoid prolonged heating of valve itself.
- 4a. Silver Brazing Method: Assemble parts to be brazed. If fluxed parts are allowed to stand, the water in the flux will evaporate, and dried flux is liable to flake off, exposing metal surfaces to oxidation. Assemble joint by inserting tube into socket hard against the stop. The assembly should be firmly supported so that it will remain in alignment during the brazing operation.

NOTE: On one-inch and larger valves, it is difficult to bring the whole joint up to temperature at one time. It will frequently be found desirable to use a double-tip torch to maintain the proper temperature over the larger area. A mild pre-heating of the whole socket area is recommended. Apply heat to parts to be joined. The preferred method is by oxy-acetylene flame. Heat tube first, beginning one inch from edge of valve. Sweep flame around tube in short strokes up and down at right angles to run of tube. To avoid burning through tube, the flame should be in continuous motion and not allowed to remain on any one point.

Apply flame to valve at base of socket. Heat uniformly, sweeping flame from valve to tube until flux on valve becomes quiet. Avoid excessive heating of valve.

When flux appears liquid and transparent on both tube and valve, start sweeping flame back and forth along axis of joint to maintain heat on parts to be joined, especially toward base of valve socket.

5. Use just enough solder: with wire solder, use 3/4" for a 3/4" valve, etc. If too much solder is used, it may flow past tube stop and clog sealing area. When joint is filled, a continuous run of solder or brazing alloy will be visible.
- 5a. Silver Brazing Method: Apply brazing wire or rod at point where tube enters valve socket. Keep flame away from rod or wire as it is fed into the joint. Move flame back and forth as alloy is drawn into joint. When the proper temperature is reached alloy will flow readily

into space between tube outer wall and valve socket. When joint is filled, a continuous rim of brazing alloy will be visible.

6. Remove excess solder with small brush while plastic, leaving a fillet around end of valve as it cools.

SILVER BRAZING

The strength of a brazed joint does not vary appreciably with the different brazing materials, but depends to a large extent upon the maintenance of proper clearance between the outside of the tube and the valve socket. The interior dimensions of silver brazing valve sockets are machined to the closest tolerances and finished smooth to promote full capillary attraction.

NOTE: Care should be observed in cleaning and in removing residues of the cleaning medium. Attempting to braze a contaminated or improperly cleaned surface will result in an unsatisfactory joint. Silver brazing alloys will not flow over or bond to oxides. Oily or greasy surfaces repel fluxes, leaving bare spots which oxidize and result in voids and inclusions.

THREADING

Grit, dirt or any foreign matter accumulated in the pipe can hinder efficient valve operation and seriously damage vital valve parts. Thoroughly clean pipe internally with air or steam.

When threading pipe, gauge pipe threads for size and length to avoid jamming pipe against seat and disc. Thoroughly clean threaded end to remove any harmful steel or iron deposits. For a good joint, use PTFE tape or pipe dope. If pipe dope is used, apply sparingly on pipe threads, *never* on valve threads. Do not allow any pipe dope into valve body in order to avoid damage to disc and seat.

Before installation, check line of flow through valve so that valve will function properly. Close valve completely before installation. Apply wrench to hex next to pipe and guard against possible distortion. After installation of valve, support line; a sagging pipe line can distort valve and cause failure.

FLANGED

There are several steps to follow to make sure that a flanged joint will be properly assembled. First, clean the joint carefully. Then loosely assemble the joint by putting in the bottom two or three bolts. Then carefully insert the gasket into place. The bottom bolts will help locate the gasket and hold it in position. Then insert the rest of the bolts into place and tighten all of the bolts evenly—not in rotation, but by the cross-over method to load the bolts evenly and eliminate concentrated stresses. The bolts should be checked for tightness after an appropriate interval of use and retightened if necessary.

Visit our website for the most current information.

Engineering Data

Flange Dimensions

Class 125 Bronze Flange Dimensions

Meets 125 lb. ASME/ANSI Standard

Nominal Size	Dim. A Flange O.D.	Dim. B Bolt Circle	Dim. C Thickness of Flange	Dia. Bolt Hole	Dia. Bolt	No. Bolt Holes
1/2	3.50	2.38	.19	.63	.50	4
3/4	3.88	2.75	.19	.63	.50	4
1	4.25	3.13	.25	.63	.50	4
1 1/4	4.63	3.50	.25	.63	.50	4
1 1/2	5.00	3.88	.31	.63	.50	4
2	6.00	4.75	.38	.75	.63	4
2 1/2	7.00	5.50	.38	.75	.63	4
3	7.50	6.00	.44	.75	.63	4
3 1/2	8.50	7.00	.44	.75	.63	8
4	9.00	7.50	.44	.75	.63	8
5	10.00	8.50	.44	.88	.75	8
6	11.00	9.50	.50	.88	.75	8
8	13.50	11.75	.63	.88	.75	8
10	16.00	14.25	.63	1.00	.88	12
12	19.00	17.00	.69	1.00	.88	12

Class 300 Bronze Flange Dimensions

Meets ASME/ANSI STD B16.24

Nominal Size	Dim. A Flange Diam.	Dim. B Min. Flange Thickness	Dim. C Bolt Circle	Dim. F Bolt Hole Diam.	Bolt Diam.	No. of ¹ Bolts
1/2	3.75	.50	2.63	.63	.50	4
3/4	4.63	.53	3.25	.75	.63	4
1	4.88	.59	3.50	.75	.63	4
1 1/4	5.25	.63	3.88	.75	.63	4
1 1/2	6.13	.69	4.50	.88	.75	4
2	6.50	.75	5.00	.75	.63	8
2 1/2	7.50	.81	5.88	.88	.75	8
3	8.25	.91	6.63	.88	.75	8
3 1/2	9.00	.97	7.25	.88	.75	8
4	10.00	1.06	7.88	.88	.75	8
5	11.00	1.13	9.25	.88	.75	8
6	12.50	1.19	10.63	.88	.75	12
8	15.00	1.38	13.00	1.00	.88	12

¹When flanges are integral with fittings or valves, holes for bolts are drilled to straddle the center line.

Class 150 Bronze Flange Dimensions

Meets ASME/ANSI STD B16.24 and Federal Spec. WW-F-406

Nominal Size	Dim. A Flange O.D.	Dim. B Bolt Circle	Dim. C Thickness of Flange	Dia. Bolt Hole	Dia. Bolt	No. Bolt Holes
1/2	3.50	2.38	.31	.63	.50	4
3/4	3.88	2.75	.34	.63	.50	4
1	4.25	3.13	.38	.63	.50	4
1 1/4	4.63	3.50	.40	.63	.50	4
1 1/2	5.00	3.88	.44	.63	.50	4
2	6.00	4.75	.50	.75	.63	4
2 1/2	7.00	5.50	.56	.75	.63	4
3	7.50	6.00	.63	.75	.63	4
3 1/2	8.50	7.00	.69	.75	.63	8
4	9.00	7.50	.69	.75	.63	8
5	10.00	8.50	.75	.88	.75	8
6	11.00	9.50	.81	.88	.75	8
8	13.50	11.75	.94	.88	.75	8

Corresponding sizes of class 150 (ASME B16.24) flange diameters and drilling templates are the same as those of the American Class 125 Cast Iron Flange Standard (ASME B16.1) and of the American Class 150 Steel Flange Standard (ASME B16.5). Class 300 (ASME B16.24) flange diameters and drilling templates are the same as those of the American Class 250 Cast Iron Flange Standard (ASME B16.1) and of the American Class 300 Steel Flange Standard (ASME B16.5).

Full face gaskets extending to the flange face edge as given in American Standard Non-Metal Gaskets for Pipe Flanges ASME B16.21 are required. Metal gaskets should not be used.

Flange Dimensions

Class 125 Cast Iron Flanges - ASME/ANSI Standard B16.1

Mates with 150-lb. Steel Flanges ASME Standard B16.5

Dimension in Inches

Size	Diameter of Flange	Thickness of Flange	Diameter of Bolt Circle	Bolt Hole Diameter	Number of Bolts	Diameter of Bolts	*Length of Bolts
2	6.00	.63	4.75	.75	4	.63	2.25
2½	7.00	.69	5.50	.75	4	.63	2.50
3	7.50	.75	6.00	.75	4	.63	2.50
3½	8.50	.81	7.00	.75	8	.63	2.75
4	9.00	.94	7.50	.75	8	.63	3.00
5	10.00	.94	8.50	.88	8	.75	3.00
6	11.00	1.00	9.50	.88	8	.75	3.25
8	13.50	1.13	11.75	.88	8	.75	3.50
10	16.00	1.19	14.25	1.00	12	.88	3.75
12	19.00	1.25	17.00	1.00	12	.88	3.75
14	21.00	1.38	18.75	1.13	12	1.00	4.25
16	23.50	1.44	21.25	1.13	16	1.00	4.50
18	25.00	1.56	22.75	1.25	16	1.13	4.75
20	27.50	1.69	25.00	1.25	20	1.13	5.00
24	32.00	1.88	29.50	1.38	20	1.25	5.50

*When bolting to steel flanges, longer bolts or stud may be required.

Class 250 Cast Iron Flanges - ASME/ANSI Standard B16.1

Mates with 300 lb. Steel Flanges ASME Standard B16.5

Dimension in Inches

Size	Diameter of Flange	Thickness of Flange	Diameter of Bolt Circle	Bolt Hole Diameter	Number of Bolts	Diameter of Bolts	*Length of Bolts
2	6.50	.88	5.00	.75	8	.63	2.75
2½	7.50	1.00	5.88	.88	8	.75	3.25
3	8.25	1.13	6.63	.88	8	.75	3.50
3½	9.00	1.19	7.25	.88	8	.75	3.50
4	10.00	1.25	7.88	.88	8	.75	3.75
5	11.00	1.38	9.25	.88	8	.75	4.00
6	12.50	1.44	10.63	.88	12	.75	4.00
8	15.00	1.63	13.00	1.00	12	.88	4.50
10	17.50	1.88	15.25	1.13	16	1.00	5.25
12	20.50	2.00	17.75	1.25	16	1.13	5.50
14	23.00	2.13	20.25	1.25	20	1.13	6.00
16	25.50	2.25	22.50	1.38	20	1.25	6.25
18	28.00	2.38	24.75	1.38	24	1.25	6.50
20	30.50	2.50	27.00	1.38	24	1.25	6.75
24	36.00	2.75	32.00	1.63	24	1.50	7.50

*When bolting to steel flanges, longer bolts or stud may be required

Visit our website for the most current information.

Steam Tables

Reprinted by permission from Macmillan Company, "Problems on Applied Thermodynamics," 1953 edition.

Abs. Press. Lb./Sq. In. p	Gage Pressure	Temp. Fah. t	SPECIFIC VOLUME			ENTHALPY			ENTROPY			Gage Pressure	Abs. Press. Lb./Sq. In. p
			Sat. Liquid vf	Evap. vfg	Sat. Vapor vg	Sat. Liquid hf	Evap. hfg	Sat. Vapor hg	Sat. Liquid sf	Evap. sfg	Sat. Vapor sg		
0.0886		32.00	0.01602	3305.7	3305.7	0	1075.1	1075.1	0	2.1865	2.1865		0.0886
0.125		40.69	0.01602	2383.7	2383.7	8.74	1070.2	1078.9	0.0176	2.1388	2.1564		0.125
0.250		59.31	0.01603	1235.8	1235.8	27.38	1059.5	1086.9	0.0542	2.0414	2.0956		0.250
0.500		79.58	0.01607	641.71	641.73	47.60	1048.0	1095.6	0.0924	1.9434	2.0358		0.500
1		101.76	0.01614	333.77	333.79	69.72	1035.5	1105.2	0.1326	1.8443	1.9769		1
5		162.26	0.01641	73.584	73.600	130.13	1000.7	1130.8	0.2347	1.6437	1.8437		5
10		193.21	0.01659	38.445	38.462	161.17	982.1	1143.3	0.2834	1.5042	1.7876		10
14.696	0	212.00	0.01672	26.811	26.828	180.07	970.3	1150.4	0.3120	1.4446	1.7566		14.696
15	.3	213.03	0.01672	26.303	26.320	181.11	969.6	1150.7	0.3135	1.4413	1.7548	.3	14.696
20	5.3	227.96	0.01683	20.093	20.110	196.16	959.9	1156.1	0.3356	1.3959	1.7315	5.3	20
30	15.3	250.34	0.01700	13.746	13.763	218.83	945.2	1164.0	0.3680	1.3312	1.6992	15.3	30
40	25.3	267.24	0.01715	10.489	10.506	236.02	933.7	1169.7	0.3919	1.2844	1.6763	25.3	40
50	35.3	281.01	0.01727	8.505	8.522	250.09	923.9	1174.0	0.4110	1.2473	1.6583	35.3	50
60	45.3	292.71	0.01738	7.162	7.179	262.10	915.4	1177.5	0.4271	1.2166	1.6427	45.3	60
70	55.3	302.92	0.01748	6.193	6.210	272.61	907.9	1180.5	0.4409	1.1905	1.6314	55.3	70
80	65.3	312.03	0.01757	5.458	5.476	282.02	901.1	1183.1	0.4532	1.1677	1.6209	65.3	80
90	75.3	320.27	0.01766	4.880	4.898	290.57	894.8	1185.4	0.4641	1.1472	1.6113	75.3	90
100	85.3	327.83	0.01774	4.415	4.433	298.43	888.9	1187.3	0.4741	1.1287	1.6028	85.3	100
110	95.3	334.79	0.01782	4.032	4.050	305.69	883.3	1189.0	0.4832	1.1118	1.5950	95.3	110
120	105.3	341.26	0.01789	3.710	3.728	312.46	878.1	1190.6	0.4916	1.0963	1.5879	105.3	120
130	115.3	347.31	0.01796	3.437	3.455	318.81	873.2	1192.0	0.4995	1.0820	1.5815	115.3	130
140	125.3	353.03	0.01803	3.202	3.220	324.83	868.5	1193.3	0.5089	1.0686	1.5755	125.3	140
150	135.3	358.43	0.01809	2.998	3.016	330.53	863.9	1194.4	0.5138	1.0560	1.5698	135.3	150
160	145.3	363.55	0.01815	2.816	2.834	335.95	859.6	1195.5	0.5204	1.0442	1.5646	145.3	160
170	155.3	368.42	0.01821	2.656	2.674	341.11	855.7	1196.3	0.5266	1.0327	1.5593	155.3	170
180	165.3	373.08	0.01827	2.564	2.532	346.07	851.1	1197.0	0.5325	1.0220	1.5545	165.3	180
190	175.3	377.55	0.01833	2.386	2.404	350.83	847.2	1198.0	0.5382	1.0119	1.5501	175.3	190
200	185.3	381.82	0.01839	2.270	2.288	355.40	843.3	1198.7	0.5436	1.0021	1.5457	185.3	200
210	195.3	385.93	0.01844	2.165	2.183	359.80	839.6	1199.4	0.5488	0.9929	1.5417	195.3	210
220	205.3	389.89	0.01849	2.067	2.086	364.05	835.8	1199.9	0.5538	0.9838	1.5376	205.3	220
230	215.3	393.70	0.01855	1.9803	1.9989	368.16	832.2	1200.4	0.5585	0.9752	1.5337	215.3	230
240	225.3	397.40	0.01860	1.8990	1.9176	372.16	828.7	1200.9	0.5632	0.9669	1.5297	225.3	240
250	235.3	400.97	0.01866	1.8244	1.8431	376.04	825.4	1201.4	0.5677	0.9590	1.5257	235.3	250
260	245.3	404.43	0.01870	1.7555	1.7742	379.78	822.0	1201.8	0.5720	0.9513	1.5213	245.3	260
270	255.3	407.79	0.01875	1.6913	1.7101	383.43	818.8	1202.2	0.5761	0.9439	1.5200	255.3	270
280	265.3	411.06	0.01880	1.6316	1.6504	386.99	815.5	1202.5	0.5802	0.9365	1.5167	265.3	280
290	275.3	414.24	0.01885	1.5758	1.5947	390.47	812.4	1202.9	0.5841	0.9296	1.5137	275.3	290
300	285.3	417.33	0.01890	1.5237	1.5426	393.85	809.3	1203.2	0.5879	0.9228	1.5107	285.3	300
350	335.3	431.71	0.01912	1.3064	1.3255	409.70	794.7	1204.4	0.6057	0.8915	1.4972	335.3	350
400	385.3	444.58	0.0193	1.1416	1.1609	424.02	780.9	1204.9	0.6215	0.8635	1.4850	385.3	400
450	435.3	456.27	0.0195	1.0123	1.0318	437.18	767.8	1205.0	0.6357	0.8382	1.4739	435.3	450
500	485.3	467.00	0.0197	0.9077	0.9274	449.40	755.5	1204.9	0.6488	0.8153	1.4641	485.3	500
550	535.3	476.94	0.0199	0.8217	0.8416	460.83	743.6	1204.4	0.6609	0.7939	1.4548	535.3	550
600	585.3	486.21	0.0201	0.7494	0.7695	471.59	731.0	1203.7	0.6721	0.7739	1.4460	585.3	600
650	635.3	494.90	0.0203	0.6879	0.7082	481.73	721.0	1202.7	0.6826	0.7563	1.4379	635.3	650
700	685.3	503.09	0.0205	0.6347	0.6552	491.49	710.1	1201.6	0.6925	0.7376	1.4301	685.3	700
750	735.3	510.83	0.0207	0.5884	0.6091	500.8	699.4	1200.2	0.7019	0.7206	1.4225	735.3	750
800	785.3	518.20	0.0209	0.5476	0.5685	509.7	689.1	1198.8	0.7108	0.7047	1.4155	785.3	800
850	835.3	525.23	0.0210	0.5116	0.5326	518.3	678.9	1197.2	0.7194	0.6893	1.4087	835.3	850
900	885.3	531.94	0.0212	0.4799	0.5006	526.6	669.0	1195.6	0.7276	0.6746	1.4022	885.3	900
950	935.3	538.38	0.0214	0.4503	0.4717	534.6	659.2	1193.8	0.7355	0.6605	1.3960	935.3	950
1000	985.3	544.56	0.0216	0.4240	0.4456	542.4	649.5	1191.9	0.7431	0.6468	1.3899	985.3	1000
1050	1035.3	550.52	0.0218	0.4011	0.4219	550.0	640.0	1190.0	0.7504	0.6335	1.3839	1035.3	1050
1100	1085.3	556.26	0.0219	0.3783	0.4002	557.4	630.4	1187.8	0.7575	0.6205	1.3780	1085.3	1100
1150	1135.3	561.81	0.0221	0.3583	0.3804	564.6	621.0	1185.6	0.7644	0.6079	1.3723	1135.3	1150
1200	1185.3	567.19	0.0223	0.3397	0.3620	571.7	611.5	1183.2	0.7712	0.5955	1.3667	1185.3	1200
1250	1235.3	572.39	0.0225	0.3228	0.3453	578.6	602.2	1180.8	0.7777	0.5835	1.3612	1235.3	1250
1300	1285.3	577.43	0.0227	0.3067	0.3294	585.4	592.9	1178.3	0.7840	0.5717	1.3557	1285.3	1300
1350	1335.3	582.32	0.0229	0.2918	0.3147	592.1	583.7	1175.8	0.7902	0.5602	1.3504	1335.3	1350
1400	1385.3	587.07	0.0231	0.2780	0.3011	598.6	574.6	1173.2	0.7963	0.5489	1.3452	1385.3	1400
1450	1435.3	591.70	0.0233	0.2652	0.2885	605.0	565.5	1170.5	0.8022	0.5379	1.3401	1435.3	1450
1500	1485.3	596.20	0.0235	0.2530	0.2765	611.4	556.3	1167.7	0.8081	0.5269	1.3350	1485.3	1500
1550	1535.3	600.59	0.0237	0.2416	0.2653	617.7	547.1	1164.8	0.8138	0.5160	1.3298	1535.3	1550
1600	1585.3	604.87	0.0239	0.2309	0.2548	623.9	538.0	1161.9	0.8195	0.5054	1.3249	1585.3	1600
1650	1635.3	609.05	0.0241	0.2207	0.2448	630.0	528.8	1158.8	0.8250	0.4948	1.3198	1635.3	1650
1700	1685.3	613.12	0.0243	0.2111	0.2354	636.1	519.6	1155.7	0.8304	0.4843	1.3147	1685.3	1700
1750	1735.3	617.11	0.0245	0.2020	0.2265	642.1	510.4	1152.5	0.8359	0.4740	1.3099	1735.3	1750
1800	1785.3	621.00	0.0247	0.1933	0.2180	648.0	501.3	1149.3	0.8412	0.4639	1.3051	1785.3	1800
1850	1835.3	624.82	0.0249	0.1850	0.2099	653.9	492.0	1145.9	0.8465	0.4537	1.3002	1835.3	1850
1900	1885.3	628.55	0.0252	0.1770	0.2022	659.9	482.5	1142.4	0.8517	0.4434	1.2951	1885.3	1900
1950	1935.3	632.20	0.0254	0.1695	0.1949	665.8	473.0	1138.8	0.8569	0.4332	1.2901	1935.3	1950
2000	1985.3	635.78	0.0257	0.1622	0.1879	671.7	463.5	1135.2	0.8620	0.4231	1.2851	1985.3	2000

Bronze Valve Figure Number Comparisons

NIBCO	Milwaukee	Stockham	Crane	Jenkins	Powell	Hammond	Walworth	NIBCO
S-111	149	B-109	1334	991	1821	IB635	55SJ	S-111
S-113	115	B-104	1324	993	1822	IB647	4SJ	S-113
S-134	1169	B-124		1242		IB648		S-134
S-136				1240				S-136
S-211-B	1502	B-17		995		IB418	3058SJ	S-211-B
S-211-Y		B-14-T	1310					S-211-Y
S-235-Y	1590-T	B-24-T		1200	1823	IB423		S-235-Y
S-311-Y								S-311-Y
S-413-B	1509	B-309	1342	997	1825	IB912	3406SJ	S-413-B
S-413-W		B-310-B						S-413-W
S-413-Y	1509-T	B-310-T						S-413-Y
S-433-B				1222				S-433-B
S-433-Y	1510-T					IB945		S-433-Y
T-104-O		B-133	459	275U				T-104-O
T-111	148	B-100	428	990	500	IB640	55	T-111
T-113	105	B-103	438	992	507	IB645	4	T-113
T-124	1152			47U	2700	IB617		T-124
T-131	1150	B-122	431	47	514	IB641	56	T-131
T-133	1140	B-128	437	670	512	IB646	14	T-133
T-134	1151	B-120	431UB	49U	2714	IB629	11	T-134
T-136	1141	B-130			2712	IB638		T-136
T-154-A	1156	B-135			375	IB650	37	T-154-A
T-174-A	1182	B-144			377	IB652	3048	T-174-A
T-174-SS	1184	B-145	634E		2377	IB654		T-174-SS
T-176-A								T-176-A
T-176-SS	1186	B-147	636E		2382	IB656		T-176-SS
T-211-B	502	B-16	1	746	650	IB440	3058	T-211-B
T-211-Y		B-13-T						T-211-Y
T-235-Y	590-T	B-22	7TF	106-A	150	IB413T	3095	T-235-Y
T-256-AP	592-A	B-62	212P		2608	IB434	3160	T-256-AP
T-275-B	572	B-66		750	120	IB412	3205	T-275-B
T-275-Y								T-275-Y
T-276-A				576	1202			T-276-A
T-276-AP	593-A	B-74	382P	576-P	2612	IB444	3260P	T-276-AP
T-311-Y	504	B-216	2			IB463		T-311-Y
T-335-Y	595-T	B-222-T	17TF	108A	151	IB454-T	3096	T-335-Y
T-375-B	582	B-237				IB469		T-375-B
T-376-AP		B-274	384P	578-P	2614	IB471		T-376-AP
T-413-B	509	B-319	37	92A	578	IB904	3406	T-413-B
T-413-W	511	B-320-B						T-413-W
T-413-Y	509-T	B-320-T				IB940		T-413-Y
T-433-B	508	B-321	137					T-433-B
T-433-Y	510-T			352	596	IB946	3412	T-433-Y
T-453-B	508	B-345	36	762A	560Y	IB944	3420	T-453-B
T-473-B	507	B-375	76E	962B	563Y	IB949	3428	T-473-B
T-473-Y								T-473-Y
T-480-Y								T-480-Y

To be used as a guide only. Some variations in detail are possible.

Visit our website for the most current information.

Iron Valve Figure Number Comparisons

NIBCO	Milwaukee	Stockham	Crane	Jenkins	Powell	Hammond	Walworth	NIBCO
F-617-O	F2885-A	G-623	465-1/2	651A	1793	IR1140	8726F	F-617-O
F-617-ON	F2891-A	G-624	475-1/2	100A	1816	IR1146HI	8727F	F-617-ON
F-619	F2882-A	G-612	461	326	1787	IR1138	8719F	F-619
F-619-N	F2890	G-613	473	98	1799	IR1144HI	8720F	F-619-N
F-667-O	F2894-A	F-667	7-1/2E	204	1797	IR330	8786F	F-667-O
F-669		F-661	3E	203			8775F	F-669
F-718-B	F2981-A	G-512	351	613	241	IR116	8906F	F-718-B
F-718-N	F2892		351-1/4		457		8906-1/2F	F-718-N
F-768-B	F2983	F-532	21E	923	256	IR313	8955F	F-768-B
F-818-B	F2988	G-515	353	614	243		8907F	F-818-B
F-869-B		F-541	30E	293	368			F-869-B
F-918-B	F2974-A	G-931	373	624	559	IR1124	8928F	F-918-B
F-918-N	F2971	G-933	373-1/2	85	1259	IR1126HI	8928-1/2F	F-918-N
F-968-B	F2970	F-947	39E	339R	576	IR322	8970F	F-968-B
Wafer Checks								
F-910	1800					IR9354		F-910
F-960						IR9355		F-960
W-910/960	1400					IR9253/9255		W-910/960
W-920-W		WG-970						W-920-W
Alloy Iron								
F-617-13	F2885-13	AG-642	14477	7651N	1893	IR1913HI	725FS	F-617-13
F-918-13	F2974-13	AG-931	14493	7624N	559P	IR1937HI	928FS	F-918-13

Comparing Ductile Iron Valves to Cast Steel Valves

Ductile Iron	Cast Steel				
	Crane	Powell	Stockham	Kitz	Velan
OS & Y Gate F-637-31 or F-637-33	47	1503	15-OF	K150-SCL	F-006C-02
NRS Gate F-639-31 or F-639-33	Not Available	Not Available	Not Available	Not Available	Not Available
Globe F-738-31	143	1531	15-GSF	K-150-SCJ	F-007C-02
Angle Globe F-838-31	145	1533	15-APF	Not Available	Not Available
Swing Check F-938-31 or F-938-33	147	1561	15-SF	K150-SCO	F-001C-02

NOTE: -31 is B584 Bronze Trim -33 is CF8M Stainless Steel Trim.

When determining valve selection, care should be taken regarding the capabilities of the materials used.
To be used as a guide only. Some variations in detail are possible.

Notes

Visit our website for the most current information.

5 year
125%
warranty

NIBCO INC. 125% LIMITED WARRANTY

Applicable to NIBCO INC. Pressure Rated Metal Valves

NIBCO INC. warrants each NIBCO pressure rated metal valve to be free from defects in materials and workmanship under normal use and service for a period of five (5) years from date put into service.

In the event any defect occurs which the owner believes is covered by this warranty, the owner should immediately contact NIBCO Technical Services, either in writing or by telephone at (888) 446-4226 or (574) 295-3000. The owner will be instructed to return said product, at the owner's expense, to NIBCO INC., or an authorized representative for inspection. In the event said inspection discloses to NIBCO INC.'s satisfaction that said valve is defective, it will be replaced at NIBCO INC.'s expense. Replacements shall be shipped free of charge to the owner. In the event of the replacement of any valve, NIBCO INC. shall further pay the owner the greater of Twenty-Five (25%) Percent of the price of the valve according to NIBCO INC.'s published suggested list price schedule in effect at the time of purchase, or Ten (\$10.00) Dollars, to apply on the cost of the installation of said replacement valve.

TO THE EXTENT PERMITTED BY LAW, THIS WARRANTY SPECIFICALLY EXCLUDES INCIDENTAL AND CONSEQUENTIAL DAMAGES OF EVERY TYPE AND DESCRIPTION RESULTING FROM ANY CLAIMED DEFECT IN MATERIAL OR WORKMANSHIP, INCLUDING BUT NOT LIMITED TO, PERSONAL INJURIES AND PROPERTY DAMAGES. Some states or countries do not allow the exclusion or limitation of incidental or consequential damages so these limitations may not apply to you. TO THE EXTENT PERMITTED BY LAW, IMPLIED WARRANTIES OF MERCHANTABILITY AND FITNESS FOR A PARTICULAR PURPOSE ARE LIMITED IN DURATION.

This warranty gives you specific legal rights, and you may also have other rights which vary from state to state and country to country.



How to Order

State quantity, figure number and size for each valve you wish to order. See individual valve catalog pages for specific or special product designations.

HOW MANY TO ORDER

NIBCO® valves are decimal packed for your convenience in handling, shipping and stock-keeping. Number in master carton varies with item.

POLICY ON RETURNS TO FACTORY

NO NIBCO valves are to be returned without prior written agreement. Transportation must be prepaid. A 20% charge will be made to cover cost of rehandling and reinspection.

TECHNICAL ASSISTANCE

Engineers, contractors, wholesalers or manufacturers may obtain special or technical assistance from any factory representative of NIBCO. Write, fax or phone.

NIBCO INC.
World Headquarters
1516 Middlebury Street
Elkhart, IN 46516-4740
USA

Phone: 1.574.295.3000
Fax: 1.574.295.3307
Technical Service Phone: 1.888.446.4226
Fax: 1.888.336.4226

To the best of our knowledge the information contained in this publication is accurate. However, NIBCO does not assume any liability whatsoever for the accuracy or completeness of such information. Final determinations of the suitability of any information or product for the use to be contemplated is the sole responsibility of the user. The manner of that use, and whether there is any infringement of patents, is also the sole responsibility of the user.

Visit our website for the most current information.

globally connecting you at all levels

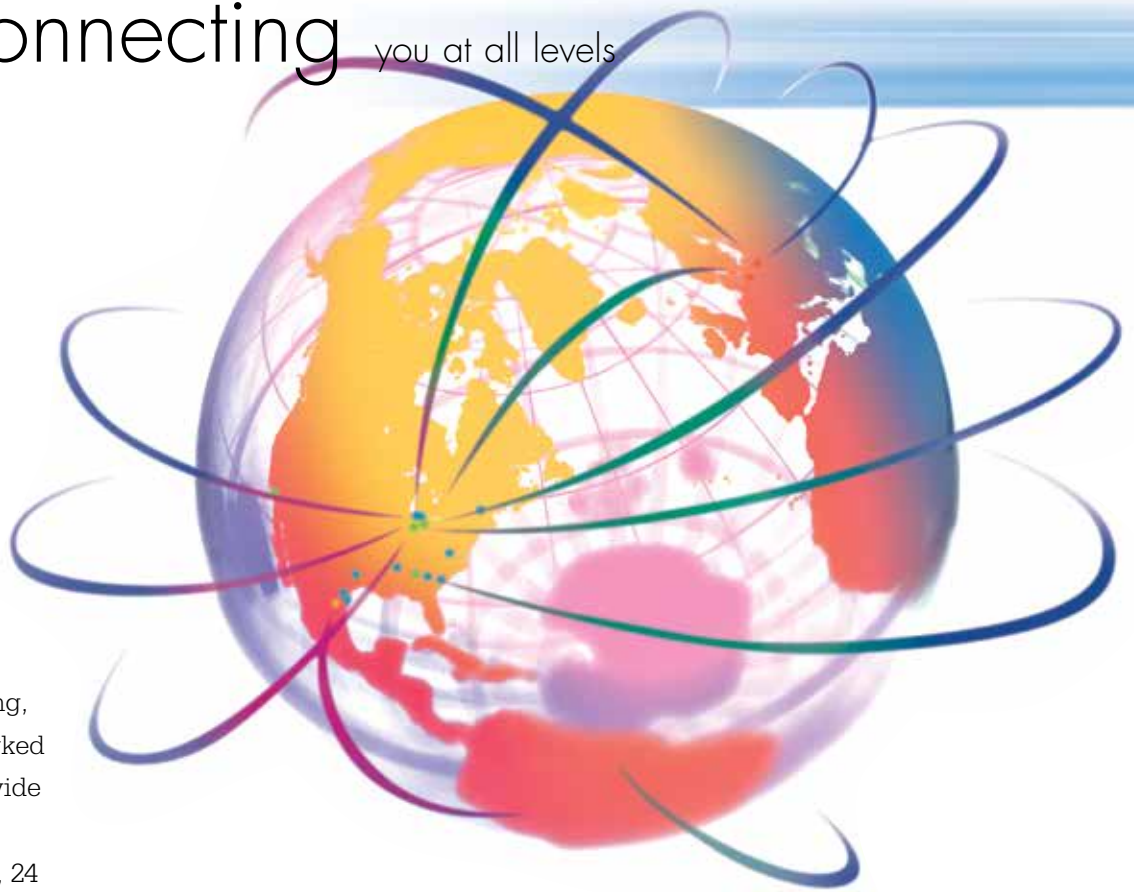

It's a new age of business, and a new way at NIBCO. From Elkhart, Indiana to Lodz, Poland, and points beyond, our company has integrated manufacturing, distribution, and networked communications to provide a seamless source of information and service, 24 hours a day, 7 days a week. But this integration hasn't happened overnight. It's been part of a long-term strategic process that has pushed us to reconsider every aspect of our business. The result? We're a vertically integrated manufacturer with the products and systems in place to deliver low cost and high quality. NIBCO products are manufactured under a Quality Management System conforming to the current revision of ISO-9001 International Standards. We know the flow control industry is only going to get more demanding, and we are more than ready. We will continue to lead. That's what NIBCO is all about.



VALVES



Pressure-rated bronze, iron and alloy-iron gate, globe and check valves • Pressure-rated bronze ball valves • Boiler specialty valves • Commercial and industrial butterfly valves • Lined butterfly valves • Circuit balancing valves • Carbon and stainless steel ball valves • ANSI flanged steel ball valves • Lined ball valves • Pneumatic and electric actuators and controls • Grooved ball and butterfly valves • High performance butterfly valves • UL/FM fire protection valves • MSS specification valves • Bronze specialty valves • Low pressure gate, globe, check and ball valves • Frostproof sillcocks • Quarter-turn supply stops • Quarterturn low pressure valves • PVC and CPVC plumbing and industrial ball valves • Bronze & Iron Y-strainers • Sample valves • Sanitary valves • Lead-Free* valves • Coil-Connect® Kits

*Weighted average lead content ≤0.25%

FITTINGS

Wrot and cast copper pressure and drainage fittings • Cast copper alloy flanges • Wrot and cast press fittings • ABS and PVC DWV fittings • Schedule 40 PVC pressure fittings • CPVC CTS fittings • CPVC CTS-to-metal transition fittings • Schedule 80 PVC and CPVC systems • CPVC BlazeMaster® fire protection fittings • Lead-Free* fittings

BlazeMaster® is a registered trademark of The Lubrizol Corporation.

*Weighted average lead content ≤0.25%

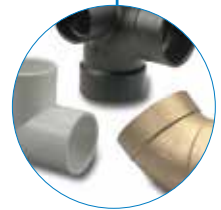

FLEXIBLE PIPING SYSTEMS



PE-RT and PEX tubing for potable and radiant applications • Insulated tubing • Risers • Ice maker tubing • Silicon Performance Bronze® fittings • Poly alloy fittings • Home Run Manifold® • Radiant heat manifolds • Ball valves and supply stops • Connections, tools and accessories • Radiant heat controls and panels

INDUSTRIAL PLASTICS

Thermoplastic pipe, valves, and fittings in PVC, Corzan® CPVC, polypropylene and PVDF Kynar® • Pneumatic and electric actuation systems • BlazeMaster® CPVC fire protection fittings

BlazeMaster® and Corzan® are registered trademarks of the Lubrizol Corporation • Kynar® is a registered trademark of Arkema Inc.



eNIBCO

EDI—Electronic Data Interchange • VMI—Vendor Managed Inventory • NIBCO.com • NIBCOpartner.com



NIBCO®
AHEAD OF THE FLOW®

NIBCO INC.
WORLD HEADQUARTERS
WEB: www.nibco.com

1516 MIDDLEBURY STREET
ELKHART, IN 46516-4740
USA

DOMESTIC CUSTOMER SERVICE
PHONE: 800.234.0227
FAX: 800.234.0557

TECHNICAL SERVICE
PHONE: 888.446.4226
FAX: 888.336.4226

INTERNATIONAL OFFICE
PHONE: +1/574.295.3327
FAX: +1/574.295.3455