



**NIBCO®**

# Fire Protection Valves Catalog

C-FPV-0324

Gate, Globe, Check, Ball, and Butterfly Valves  
for Fire Protection Applications



## QUALITY PRODUCTS SINCE 1904

A recognized brand leader bringing flow control products and technologies to market, NIBCO has a history of success and innovation in the plumbing industry.

Headquartered in Elkhart, Indiana, we operate multiple manufacturing plants and distribution centers strategically located throughout the United States and globally, and offer more than 36,000 SKUs, including our NIBCO® family brands, Webstone®, Chemtrol® and Sure Seal®.

We have vertically integrated manufacturing, distribution and networked communications to provide a seamless source of information and service, 24/7. We place great emphasis on personal connections with our factory direct sales, live customer service and technical service support. We also offer unique programs to support our customers' success, including our NIBCO Partner program, Vendor Managed Inventory and EDI for wholesalers.

More than 90 percent of NIBCO-branded products are manufactured in the U.S. using high-quality materials and innovative processes and technologies to improve product performance and quality. For every high-quality valve or fitting made at NIBCO, each is made with pride by the hundreds of NIBCO associates who work there.

Today, NIBCO is a fifth-generation, family- and associate-owned business. Since 1904, we've pioneered many products and processes. As the flow control industry continues to become more demanding, we remain focused on what has made us successful: delivering more than a product and making business better for each of our customers.



[VISIT OUR WEBSITE TO LEARN MORE](#)

# Table of Contents



Visit our website for the most current information .

	Page		Page
<b>Bronze UL/FM Valves and Trim</b> .....	<b>4-17</b>	<b>Hi Rise Valves</b> .....	<b>34-39</b>
Illustrated Index .....	4	Illustrated Index .....	34
T-104-O .....	5	F-637-31 .....	35
KT/KG-505 .....	6	F-667-0 .....	36
T-103-HC .....	7	F-697-0 .....	37
T-331-HC .....	8	F-938-31 .....	38
KT-65-UL .....	9	F-968-B .....	39
KT-211-W-UL .....	10	<b>Iron UL/FM Butterfly Valves</b> .....	<b>40-48</b>
KT-67-UL .....	11	Illustrated Index .....	40
T-301-W .....	12	WD/LD-3510-4/8 .....	41
KT-291-W3 .....	13	WD/LD-3510-C-8 .....	42
KT-403-W .....	14	GD-4865-8N .....	43
T-480 .....	15	GD-4865-C-8N .....	44
T-585-70 .....	16	GD-6865-8N .....	45
KT-580/585-70-UL .....	17	GD-6865-C-8N .....	46
<b>Iron UL/FM Valves</b> .....	<b>18-33</b>	Butterfly Indicator Post .....	48
Illustrated Index .....	18	<b>Adjustable Height Upright</b>	
F-607-OTS .....	19	<b>Indicator Posts Series NIP-1AU</b> .....	<b>49-58</b>
F-607-RWS .....	20	<b>Wall Mount Indicator Posts</b>	
F-607-RWSB .....	21	<b>Series NIP-2AW</b> .....	<b>59-68</b>
F/M-609 .....	22	TS-2M Replacement Instructions .....	67
F/M-609-RWS .....	23	TS4 Replacement Instructions .....	68
FM609-RWS .....	24	<b>Properties of Valve Materials</b> .....	<b>70-71</b>
NIP-1AU .....	25	<b>Flow Data</b> .....	<b>72</b>
NIP-2AW .....	27	<b>Gate Valve Dimensions for Supv. Switch</b> .....	<b>73</b>
KG-900-W-LF .....	28	<b>Grooved Pipe Specification</b> .....	<b>74</b>
KG-900-W-LF 350 .....	29	<b>Figure Number Comparisons</b> .....	<b>75</b>
KW-900-W-LF .....	30	<b>Typical Fire Sprinkler System</b> .....	<b>76</b>
F-908-W .....	31	<b>Replacement Handwheel Charts</b> .....	<b>77-78</b>
G-917-W .....	32	<b>Warranty</b> .....	<b>82</b>
G-997 .....	33		



De-alloying corrosion, known as "Dezincification," was effectively eradicated from valve products in the 1950s. Today, however, this problem has returned with the increased use of high-zinc alloys (commonly referred to as 'Yellow Brass') in forged and cast valves typically produced outside the United States.

Dezincification selectively removes zinc from the alloy, leaving behind a porous, copper-rich structure that has little mechanical strength. The physical attributes of an in-service valve with dezincification includes a white powdery substance or mineral stains on its exterior surface.

What's the cure? On all bronze valves the metal components in the waterway must not contain more than 15% zinc in their chemical makeup. As a standard NIBCO bronze fire protection valves are made to be "Dezincification Resistant," which is a seal of quality and longevity.

# Bronze UL/FM & Trim Valves

## Illustrated Index



<p>UL/ULC Listed • FM Approved Bronze Gate Valve Outside screw and yoke 175 PSI WWP</p>  <p><b>T-104-0</b> Sizes ½" thru 2" Threaded ends <b>Page 5</b></p>	<p>UL Listed • FM Approved Bronze Ball Valve with weather-proof indicating gear operator 300 PSI WWP</p>  <p><b>KT-505-W-8</b> Threaded ends <b>KG-505-W-8</b> Grooved ends <b>Page 6</b></p>	<p>UL Listed • FM Approved Bronze Hose Gate Valve with cap and chain 175 PSI WWP</p>  <p><b>T-103-HC</b> Size 2½" Threaded ends <b>Page 7</b></p>	<p>UL Listed • FM Approved Bronze Angle Valve with cap and chain 300 PSI WWP</p>  <p><b>T-331-HC</b> Size 2½" Threaded ends <b>Page 8</b></p>
<p>UL Listed Bronze Globe Valve Rubber Disc 175 PSI WWP</p>  <p><b>KT-65-UL</b> Sizes ¼" thru 1" Threaded ends <b>Page 9</b></p>	<p>UL Listed Bronze Globe Valve Rubber Disc 175 PSI WWP</p>  <p><b>KT-211-W-UL</b> Sizes 1¼" thru 3" Threaded ends <b>Page 10</b></p>	<p>UL Listed Bronze Angle Valve Rubber Disc 175 PSI WWP</p>  <p><b>KT-67-UL</b> Sizes ½" thru 1" Threaded ends <b>Page 11</b></p>	<p>UL/ULC Listed Bronze Angle Valve Rubber Disc 175 PSI WWP</p>  <p><b>T-301-W</b> Sizes 1¼" thru 3" Threaded ends <b>Page 12</b></p>
<p>Bronze Side Outlet Globe Valve Rubber Disc 400 PSI WWP</p>  <p><b>KT-291-W3</b> Size ¼" Threaded ends <b>Page 13</b></p>	<p>Bronze Check Valve Horizontal swing Rubber Disc 200 PSI WWP</p>  <p><b>KT-403-W</b> Sizes ½" thru 3" Threaded ends <b>Page 14</b></p>	<p>Bronze Check Valve Spring Actuated Inline Lift Rubber Buna-N Disc 250 PSI WWP</p>  <p><b>T-480</b> Sizes ¾" thru 2" Threaded ends <b>Page 15</b></p>	<p>Bronze Ball Valve Full Port PTFE Seats 600 PSI WWP</p>  <p><b>T-585-70</b> Sizes ¼" thru 2" Threaded ends <b>Page 16</b></p>
<p>UL 258 Listed • FM Approved Bronze Ball Valve PTFE Seats 300 PSI WWP</p>  <p><b>KT-580-70-UL</b> <b>KT-585-70-UL</b> Sizes ¼" thru 3" Threaded ends <b>Page 17</b></p>			

Visit our website for the most current information.

## 175 PSI WWP Bronze Gate Valves

Fire Protection Valve • Screw-Over Bonnet •  
Outside Screw and Yoke • Solid Wedge

**175 PSI/12.1 Bar Non-Shock Cold Water  
(400 PSI Non-Shock CWP General Service)**



**T-104-0**  
Threaded

UL/ULC LISTED\* • FM APPROVED •  
APPROVED BY THE NEW YORK CITY B.S.A. 143-69-SA

### MATERIAL LIST

PART	SPECIFICATION
1. Set Screw	Steel ASTM A307
2. Handwheel	Malleable Iron
3. Yoke Bushing	Brass ASTM B16
4. Gland Bolts	Steel ASTM A307 Zinc Plated
5. Packing Gland	Bronze ASTM B62
6. Packing	Non Asbestos Aramid Fibers w/Graphite
7. Bonnet	Bronze ASTM B62
8. Stem	Silicon Bronze ASTM B371 Alloy C69430
9. Stem Collar	Silicon Bronze ASTM B371 Alloy C69430
10. Wedge Pin	Bronze ASTM B140 Alloy C31400
11. Wedge	Bronze ASTM B62
12. Body	Bronze ASTM B62

### DIMENSIONS—WEIGHTS—QUANTITIES

Size	Dimensions				Handwheel		Box Qty.	Master Ctn. Qty.			
	A		B		Weight						
In. mm.	In.	mm.	In.	mm.	In.	mm.	Lbs.	Kg.			
½	15	2.19	59	5.88	149	3.25	88	2.28	1.04	1	20
¾	20	2.44	62	6.44	164	3.25	88	2.83	1.29	1	20
1	25	2.88	73	7.44	189	3.25	88	3.67	1.67	1	10
1¼	32	3.13	79	8.69	221	4.00	100	5.83	2.65	1	10
1½	40	3.38	84	9.38	238	4.00	100	6.84	3.11	1	10
2	50	3.44	87	10.59	269	3.50	89	9.74	4.44	1	6

\* Compliance with Standard for Gate Valves for Fire Protection Service, UL 262, and the Canadian Requirements.

**WARNING:** This product can expose you to chemicals including lead, which is known to the State of California to cause cancer and birth defects or other reproductive harm. For more information go to [www.P65Warnings.ca.gov](http://www.P65Warnings.ca.gov).

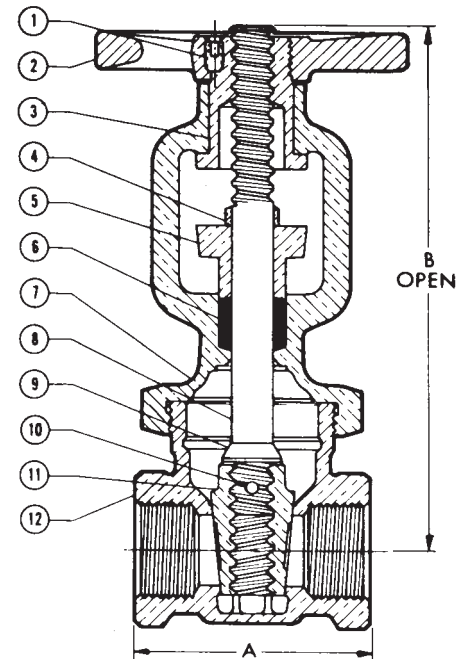

**T-104-0**  
NPT x NPT

Visit our website for the most current information.

# 300 PSI WWP Bronze Ball Valves

Fire Protection Valve • Threaded or Grooved Body Style • Full Port Design 1" - 2" • Standard Port Design 2½"

## 300 PSI/20.7 Bar Non-Shock Cold Water

CONFORMS TO MSS SP-110 • FM APPROVED FOR INDOOR AND OUTDOOR SERVICE • UL LISTED FOR INDOOR AND OUTDOOR SERVICE\* • CALIFORNIA STATE FIRE MARSHAL LISTING NO. 7770-1243:103

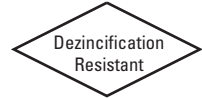

**KT-505-W-8**  
Threaded

**KG-505-W-8**  
Grooved (2" & 2½" only)

MATERIAL LIST	
PART	SPECIFICATION
1. Body	Bronze ASTM B584 Alloy C84400
2. Ball	Chrome Plated Brass ASTM B124 Alloy C37700
3. Seat Ring	Carbon-filled PTFE
4. Thrust Washer	Reinforced PTFE
5. Stem	Bronze ASTM B371 Alloy C69430
6. Stem O-Ring	Nitrile
7. Retaining Washer	Brass
8. Retaining Ring	Steel
9. Ground Wire Screw	Steel
10. 505-8 Act Assy.	Brass
11. Body End	Bronze ASTM B584 Alloy C84400
12. Mounting Screw	Steel
13. Lock Washer	Steel
14. Handle Pin	Brass
15. Hand Wheel	Steel/plastisol coated (1¼" - 2½") Brass Tee Handle (1")
16. Indicator Flag	Painted Steel
17. Body Gasket	Elastomer
18. Lead Screw O-Ring	Nitrile
19. Thrust Washer	Anti-friction Polymer
20. Cover Gasket	Buna-N
21. Flag Seal O-Ring	Nitrile
22. Tamper-Proof Screw	Stainless Steel
23. Pipe Plug (-4 units)	Stainless Steel (Not shown)

Refer to page 67 for details for TS-2M Switch Kit.

\* Compliance with the applicable requirements of the Standard for Butterfly Valves for Fire Protection Service, UL 1091B.

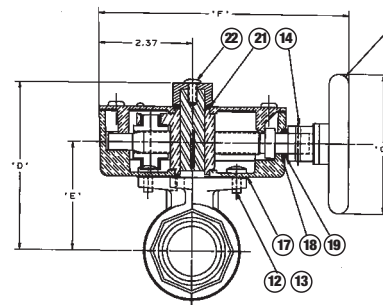
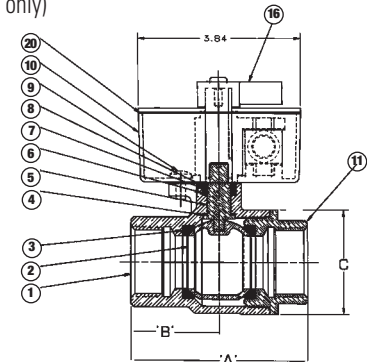

KT-505-W

## DIMENSIONS—WEIGHTS—QUANTITIES

Size	Dimensions										C <sub>v</sub> †	Weight														
	A		B		C	D	E	F	G	H		Threaded		Grooved		Box Qty.	Master Ctn. Qty.									
	In. mm.	In. mm.	In. mm.	In. mm.								Lbs.	Kg.	Lbs.	Kg.											
1	25	3.33	85	—	—	1.66	42	—	—	2.11	54	3.81	97	2.31	59	6.14	156	1.75	44	57	6.1	2.77	—	—	1	10
1¼	32	4.18	106	—	—	2.09	53	—	—	2.46	62	4.21	107	2.72	69	6.33	161	3.50	89	103	7.1	3.23	—	—	1	8
1½	40	4.70	119	—	—	2.35	60	—	—	2.95	74	4.46	113	2.97	75	6.33	161	3.50	89	143	8.1	3.68	—	—	1	4
2	50	5.15	131	6.71	170	2.57	65	3.36	85	3.69	94	4.67	119	3.18	81	6.33	161	3.50	89	245	10.7	4.86	9.7	4.40	1	4
2½	65	5.65	144	7.28	185	2.92	74	3.64	93	3.75	95	4.67	119	3.18	81	6.33	161	3.50	89	183	13.0	5.91	12.6	5.73	1	4

† Note: C<sub>v</sub> is defined as the flow in GPM that a valve will carry with a pressure drop of 1.0 psi when the media is water at 60° F.

DO NOT USE FOR NATURAL GAS

**WARNING:** This product can expose you to chemicals including lead, which is known to the State of California to cause cancer and birth defects or other reproductive harm. For more information go to [www.P65Warnings.ca.gov](http://www.P65Warnings.ca.gov).

Visit our website for the most current information.

# 175 PSI WWP Bronze Hose Gate Valves

Fire Protection Valve • Screw-In Bonnet • Non-Rising Stem • Solid Wedge

175 PSI/12.1 Bar Non-Shock Cold Water

CONFORMS TO MSS SP-80 • UL LISTED\* •  
FM APPROVED

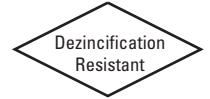

**T-103-HC**  
Threaded  
w/Cap and Chain

### MATERIAL LIST

PART	SPECIFICATION
1. Handwheel Nut	Brass ASTM B16
2. Handwheel	Malleable Iron
3. Stem	Silicon Bronze ASTM B371 Alloy C69430
4. Packing Nut	Bronze ASTM B62
5. Packing Gland	Brass ASTM B16
6. Packing	Non Asbestos Aramid Fibers w/Graphite
7. Stuffing Box	Bronze ASTM B62
8. Bonnet	Bronze ASTM B62
9. Body	Bronze ASTM B62
10. Wedge	Bronze ASTM B62
11. Hose Cap	Bronze ASTM B62
12. Hose Cap Gasket	Rubber
13. Safety Chain	Brass

\* Compliance with the Standard for Hose Valves for Fire Protection Service, UL 668.

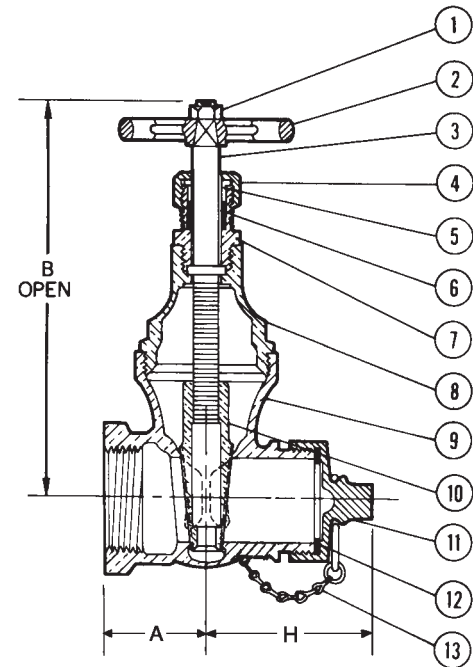

### DIMENSIONS—WEIGHTS—QUANTITIES

Size	Dimensions						Weight		Box Qty.	Master Ctn. Qty.
	A		B		H		Lbs.	Kg.		
In. mm.	In.	mm.	In.	mm.	In.	mm.				
2½ 65	3.00	80	11.38	288	4.75	121	18.52	8.39	1	2

NOTE: National Fire Hose Threads

**WARNING:** This product can expose you to chemicals including lead, which is known to the State of California to cause cancer and birth defects or other reproductive harm. For more information go to [www.P65Warnings.ca.gov](http://www.P65Warnings.ca.gov).

**T-103-HC**  
NPT x ANFH (NFPA)  
Hose 7.5 Threads  
Per Inch

Visit our website for the most current information.

# 300 PSI WWP Bronze Hose Angle Valves

Fire Protection Valve • Rising Stem • Renewable Disc • Screw-in Bonnet

300 PSI/20.7 Bar Non-Shock Cold Water

CONFORMS TO MSS SP-80 • UL LISTED\* •  
FM APPROVED

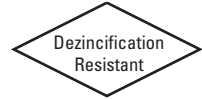

## MATERIAL LIST

PART	SPECIFICATION
1. Handwheel Nut	Brass ASTM B16
2. Handwheel	Malleable Iron
3. Stem	Silicon Bronze ASTM B371 Alloy C69430
4. Packing Nut	Bronze ASTM B62
5. Packing Gland	Bronze ASTM B16 or ASTM B62
6. Packing	Non Asbestos Aramid Fibers w/Graphite
7. Bonnet	Bronze ASTM B62
8. Body	Bronze ASTM B62
9. Disc Holder Nut	Bronze ASTM B62
10. Drive Screw	18-8SS or Silicon Bronze ASTM B 411 Alloy C64700
11. Disc Holder	Bronze ASTM B62
12. Hose Cap	Bronze ASTM B62
13. Seat Disc	Rubber
14. Hose Cap Gasket	Rubber
15. Safety Chain	Brass
16. Seat Disc Nut	Bronze ASTM B62
17. Cotter Key	Brass

\* Compliance with the Standard for Hose Valves for Fire Protection Service, UL 668.



**T-331-HC**  
Threaded  
w/Cap and Chain

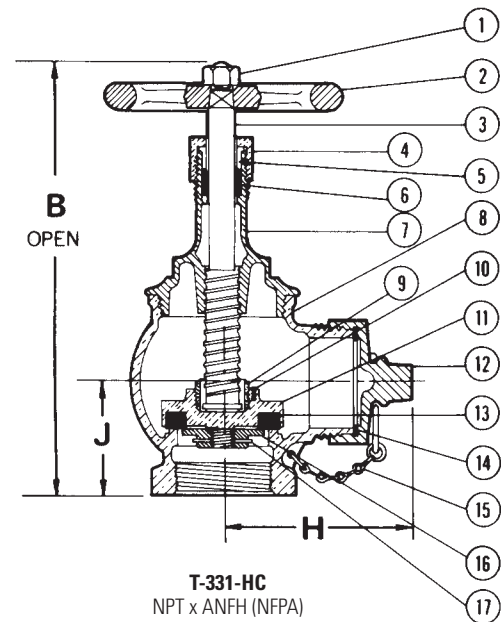

**T-331-HC**  
NPT x ANFH (NFPA)  
Hose 7.5 Threads  
Per Inch

## DIMENSIONS—WEIGHTS—QUANTITIES

Size	Dimensions						Weight		Box Qty.	Master Ctn. Qty.
	B		H		J		Lbs.	Kg.		
In. mm.	In. mm.	In. mm.	In. mm.	In. mm.	In. mm.	Lbs.	Kg.			
2½ 65	10.50 267	5.13 130	3.06 78	15.61 7.08				1	4	

NOTE: National Fire Hose Threads

**WARNING:** This product can expose you to chemicals including lead, which is known to the State of California to cause cancer and birth defects or other reproductive harm. For more information go to [www.P65Warnings.ca.gov](http://www.P65Warnings.ca.gov).

Visit our website for the most current information.

# 175 PSI WWP Bronze Globe Valves

Fire Protection Valve • Threaded Ends • Rubber Disc • Screw Over Bonnet

175 PSI/12.1 Bar Non-Shock Cold Water

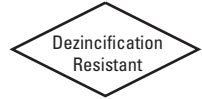

UL LISTED\*

## MATERIAL LIST

PART	SPECIFICATION
1. Handwheel	Aluminum
2. Handwheel Screw	Carbon Steel Stainless Steel (1")
3. Stem	Bronze ASTM B584 Alloy C84400 or ASTM B505 Alloy C84400
4. Packing Nut	Bronze ASTM B584 Alloy C83600 or ASTM B16
5. Packing	Graphite Impregnated (Non Asbestos)
6. Bonnet	Bronze ASTM B584 Alloy C84400
7. Body	Bronze ASTM B584 Alloy C84400
8. Seat Disc	EPDM Rubber (1/4" - 3/8") Nitrile (1/2" - 1")
9. Seat Screw	Stainless Steel
10. Pack Washer	Sheet Brass

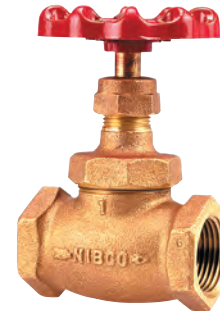

**KT-65-UL**  
Threaded

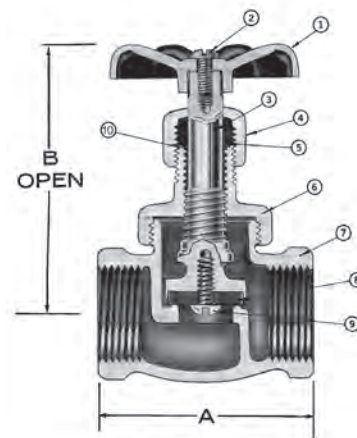

**KT-65-UL**  
NPT x NPT

## DIMENSIONS—WEIGHTS—QUANTITIES

Size	Dimensions				Weight		Box Qty.	Master Ctn. Qty.	
	In.	mm.	In.	mm.	Lbs.	Kg.			
†1/4	8	2.00	50	2.75	70	.48	.22	10	100
†3/8	10	2.00	50	2.75	70	.45	.20	10	100
1/2	15	2.28	58	3.12	79	.68	.31	10	60
3/4	20	2.28	58	3.12	79	.74	.34	10	60
1	25	3.12	79	4.50	114	1.68	.76	5	25

\* UL Listed for Trim and Drain use (Subject 258) – sizes 1/2", 3/4", 1".

† Size 1/4" and 3/8" supplied as KT-65 (Not UL Listed). Subject to AHJ Approval.

NOTE: See KT-211-W-UL for 1 1/4" - 2" sizes.

**WARNING:** This product can expose you to chemicals including lead, which is known to the State of California to cause cancer and birth defects or other reproductive harm. For more information go to [www.P65Warnings.ca.gov](http://www.P65Warnings.ca.gov).

Visit our website for the most current information.

# 175 PSI WWP Bronze Globe Valves

Fire Protection Valve • Screw-In Bonnet • Integral Seat • Renewable Disc

175 PSI/12.1 Bar Non-Shock Cold Water

CONFORMS TO MSS SP-80 • UL LISTED\*

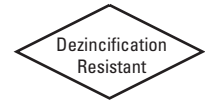

**KT-211-W-UL**  
Threaded

## MATERIAL LIST

PART	SPECIFICATION
1. Handwheel Nut	300 Series Stainless Steel
2. Identification Plate	Aluminum
3. Handwheel	Aluminum Commercial Alloy 380
4. Stem	Silicon Bronze ASTM B371 Alloy C69430
5. Packing Gland	Bronze ASTM B62 or ASTM B584 Alloy C84400 or ASTM B282 or ASTM B16
6. Packing Nut	Bronze ASTM B62 or ASTM B584 Alloy C84400 or ASTM B16
7. Packing	Non Asbestos Aramid Fibers w/Graphite
8. Bonnet	Bronze ASTM B62
9. Disc Holder Nut	Bronze ASTM B140 Alloy C31400 or B62
10. Disc Holder	Bronze ASTM B62±/ ASTM B 9 Alloy C65100 w/SS Washer
11. Seat Disc	Nitrile (W) (1¼" - 2") PTFE (Y) (2½" - 3")
‡12. Disc Nut	Bronze ASTM B62/ASTM 89 Alloy C65100 w/SS Washer
13. Body	Bronze ASTM B62

‡ 2½" and 3" size only.

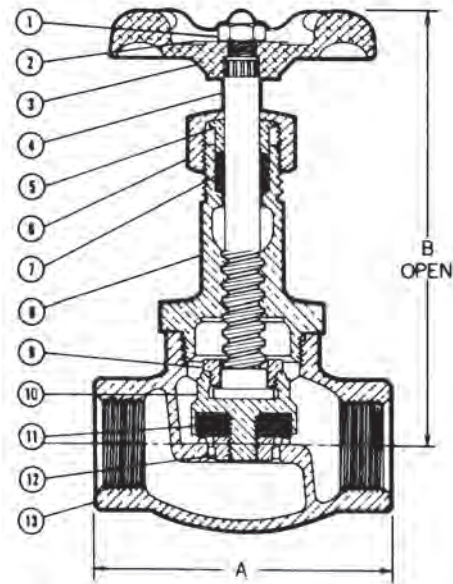

**KT-211-W-UL**  
NPT x NPT

## DIMENSIONS—WEIGHTS—QUANTITIES

Size	Dimensions				Weight		Box Qty.	Master Ctn. Qty.
	A		B		Lbs.	Kg.		
In. mm.	In.	mm.	In.	mm.				
1¼ 32	4.31	110	6.13	156	3.55	1.61	2	10
1½ 40	4.69	119	7.19	183	5.50	2.49	2	10
2 50	5.63	143	7.94	202	8.25	3.75	2	6
**2½ 65	6.63	168	10.19	259	15.40	7.00	1	2
**3 80	7.75	197	11.19	284	22.44	10.20	1	2

\* UL Listed for Trim and Drain use (Subject 258) – sizes 1¼", 1½", 2".

\*\* Sizes 2½" and 3" supplied as T-211-Y with PTFE seat disc. Subject to AHJ Approval.

NOTE: See KT-65-UL for ½"-1" sizes.

**WARNING:** This product can expose you to chemicals including lead, which is known to the State of California to cause cancer and birth defects or other reproductive harm. For more information go to [www.P65Warnings.ca.gov](http://www.P65Warnings.ca.gov).

Visit our website for the most current information.

# 175 PSI WWP Bronze Angle Valves

Fire Protection Valve • Threaded Ends • Rubber Disc • Screw Over Bonnet

175 PSI/12.1 Bar Non-Shock Cold Water

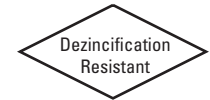

UL LISTED\*

## MATERIAL LIST

PART	SPECIFICATION
1. Handwheel	Aluminum
2. Handwheel Screw	Carbon Steel (1/2" & 3/4") Stainless Steel (1")
3. Stem	Bronze ASTM B584 Alloy C84400
4. Packing Nut	Bronze ASTM B584 Alloy C83600 or ASTM B16
5. Packing	Graphite Impregnated (Non Asbestos)
6. Bonnet	Bronze ASTM B584 Alloy C84400
7. Body	Bronze ASTM B584 Alloy C84400
8. Seat Disc	Nitrile Rubber
9. Seat Screw	Stainless Steel
10. Pack Washer	Sheet Brass



**KT-67-UL**  
Threaded

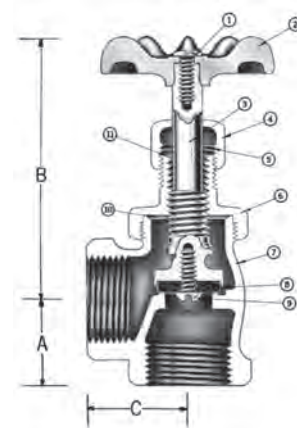

**KT-67-U**  
NPT x NPT

## DIMENSIONS—WEIGHTS—QUANTITIES

Size	Dimensions						Weight		Box Qty.	Master Ctn. Qty.	
	A		B		C		Lbs.	Kg.			
In.	mm.	In.	mm.	In.	mm.	In.	mm.				
1/2	15	.94	24	3.25	83	1.06	27	.62	.28	10	60
3/4	20	1.02	26	3.12	79	1.20	30	.70	.32	10	60
1	25	1.80	46	4.50	114	1.62	41	1.57	.71	5	25

\* UL Listed for Trim and Drain Use, (Subject 258).

NOTE: See T-301-W for 1 1/4" -2" sizes.

**⚠ WARNING:** This product can expose you to chemicals including lead, which is known to the State of California to cause cancer and birth defects or other reproductive harm. For more information go to [www.P65Warnings.ca.gov](http://www.P65Warnings.ca.gov).

Visit our website for the most current information.

# 175 PSI WWP Bronze Angle Valves

Fire Protection Valve • Screw-in Bonnet • Integral Seat • Renewable Disc

175 PSI/12.1 Bar Non-Shock Cold Water

CONFORMS TO MSS SP-80 • UL/ULC LISTED\*

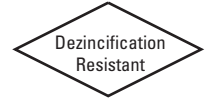

**T-301-W**  
Threaded

## MATERIAL LIST

PART	SPECIFICATION
1. Handwheel Nut	300 Series Stainless Steel
2. Identification Plate	Aluminum
3. Handwheel	Aluminum Commercial Alloy C38000
4. Stem	Silicon Bronze ASTM B371 Alloy C69430
5. Packing Gland	Bronze ASTM B62/ ASTM B16†/ ASTM B584 Alloy C84400
6. Packing Nut	Bronze ASTM B62/ ASTM B584 Alloy C84400/ASTM B16
7. Packing	Non Asbestos Aramid Fibers w/Graphite
8. Bonnet	Bronze ASTM B62 Alloy C83600
9. Disc Holder Nut	Bronze ASTM B62 Alloy C83600
10. Disc Holder	Bronze ASTM B62 Alloy C83600
11. Seat Disc	Nitrile (W) (1 1/4" - 2") PTFE (Y) (2 1/2" - 3")
12. Seat Disc Nut	Bronze ASTM B62†/ ASTM B96 Alloy C65100 w/SS Washer
13. Body	Bronze ASTM B62/B584 Alloy C83600

‡ 2 1/2" and 3" size only.  
† Not on 2"

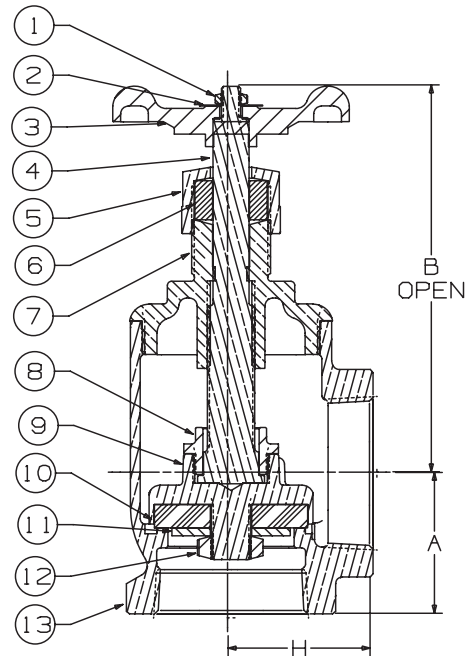

**T-301-W**  
NPT x NPT

## DIMENSIONS—WEIGHTS—QUANTITIES

Size	Dimensions						Weight		Box Qty.	Master Ctn. Qty.
	A		B		H		Lbs.	Kg.		
In. mm.	In.	mm.	In.	mm.	In.	mm.				
1 1/4 32	2.19	56	6.13	156	2.19	56	3.71	1.69	1	10
1 1/2 40	2.38	60	7.19	183	2.38	60	5.54	2.52	1	10
2 50	2.25	57	7.25	184	2.25	57	6.72	3.05	1	10
**2 1/2 65	3.19	81	10.56	268	3.19	81	16.13	7.33	1	2
**3 80	3.88	86	11.13	283	3.88	86	21.72	9.87	1	2

\* UL/ULC Listed for sizes for trim and drain use (Subject 258) - Sizes 1 1/4", 1 1/2", 2".

\*\* Sizes 2 1/2" and 3" supplied as T-311-Y with PTFE seat disc. Subject to AHJ Approval.

NOTE: See KT-67-UL for 1/2"-1" sizes.

**WARNING:** This product can expose you to chemicals including lead, which is known to the State of California to cause cancer and birth defects or other reproductive harm. For more information go to [www.P65Warnings.ca.gov](http://www.P65Warnings.ca.gov).

Visit our website for the most current information.

## 400 PSI WWP Bronze Side Outlet Globe Valves

Fire Protection Valve • 3-Way Valve • Screw-In Bonnet • Integral Seat • Renewable Disc

400 PSI/27.6 Bar Non-Shock Cold Water

Dezincification  
Resistant

### MATERIAL LIST

PART	SPECIFICATION
1. Handwheel Screw	Zinc Plated Steel
2. Handwheel	Aluminum ASTM B85 Alloy C38000
3. Stem	ASTM B133 Alloy C10200
4. Packing Nut	ASTM B16 Alloy C36000
5. Packing	Non Asbestos Aramid Fibers w/Graphite
6. Bonnet	Bronze ASTM B584 Alloy C84400
7. Disc	Nitrile
8. Disc Screw	Stainless Steel ASTM A276 Alloy S43000
9. Body	Bronze ASTM B584 Alloy C84400



**KT-291-W3**  
Threaded

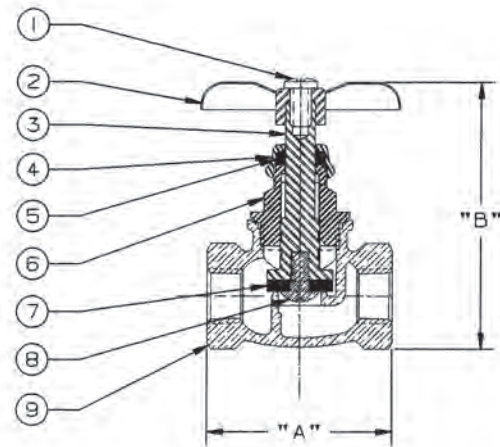

**KT-291-W3**  
NPT x NPT x NPT

### DIMENSIONS—WEIGHTS—QUANTITIES

Size	Dimensions						Weight		Box Qty.	Master Ctn.	Qty.
	A		B		C		Lbs.	Kg.			
In.	mm.	In.	mm.	In.	mm.	In.	mm.				
1/4	8	1.75	44	2.25	57	.94	24	.41	.19	10	100

**⚠ WARNING:** This product can expose you to chemicals including lead, which is known to the State of California to cause cancer and birth defects or other reproductive harm. For more information go to [www.P65Warnings.ca.gov](http://www.P65Warnings.ca.gov).

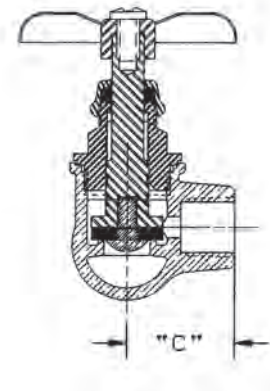

Visit our website for the most current information.

# 200 PSI WWP Bronze Check Valves

Fire Protection Valve • Horizontal Swing • Rubber Disc

200 PSI/13.8 Bar Non-Shock Cold Water

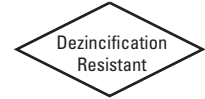

CONFORMS TO MSS SP-80

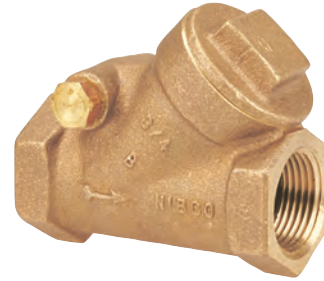

**KT-403-W**  
Threaded

### MATERIAL LIST

PART	SPECIFICATION
1. Bonnet	Bronze ASTM B 62 C83600
2. Body	Bronze ASTM B 62 C83600
3. Hinge Pin	ASTM A276 S30400 or S31600
4. Disc Hanger	Bronze ASTM B 62 C83600 or MPIF SS-316N1-25
5. Hanger Nut	Bronze ASTM B 16 C36000
6. Disc Holder	Bronze ASTM B 62 C83600
7. Seat Disc	Nitrile (W) PTFE (Y)‡
8. Seat Disc Nut	Brass ASTM B 16 C36000 or B 96 C65100
9. Hinge Pin Plug	Bronze ASTM B 140 C31400 or B 16 C36000 (Not Shown)
*10. Seat Disc Washer	ASTM F594 S30400 or S31600

\* Sizes 1", 1¼" and 1½" only. No Seat Disc Washers on 1/2" and 3/4" with PTFE (Y) discs.

‡ 2½" and 3" size only.

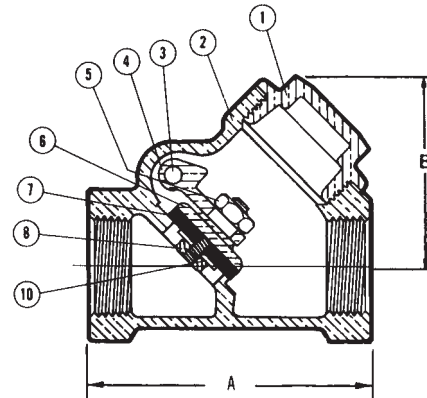

**KT-403-W**  
NPT x NPT

### DIMENSIONS—WEIGHTS—QUANTITIES

Size	Dimensions				Weight		Box Qty.	Master Ctn. Qty.
	A		B		Lbs.	Kg.		
In. mm.	In.	mm.	In.	mm.				
½ 15	2.44	62	1.69	43	.58	.26	10	50
¾ 20	2.94	75	1.88	48	.92	.42	10	50
1 25	3.56	90	2.31	59	1.55	.70	5	30
1¼ 32	4.19	106	2.69	68	2.32	1.05	5	20
1½ 40	4.50	114	2.94	75	3.00	1.36	2	10
2 50	5.25	133	3.81	97	4.87	2.21	2	10
2½ 65	8.00	203	5.06	129	11.48	5.22	1	5
3 80	9.25	235	6.25	159	17.53	7.97	1	4

Sizes 2½" and 3" supplied as T-433-Y with PTFE seat disc.

NIBCO check valves may be installed in both horizontal and vertical lines with upward flow or in any intermediate position.

**WARNING** - Valve must be installed downstream of receiver tank if used in line with reciprocating air compressor.

**WARNING:** This product can expose you to chemicals including lead, which is known to the State of California to cause cancer and birth defects or other reproductive harm. For more information go to [www.P65Warnings.ca.gov](http://www.P65Warnings.ca.gov).

Visit our website for the most current information.

# 250 PSI WWP Bronze Ring Check® Valves

Fire Protection Valve • Inline Lift Type • Rubber Discs • Spring Actuated

**250 PSI/17.2 Bar Non-Shock Cold Working Pressure** ♦



## MATERIAL LIST

PART	SPECIFICATION
1. Body	Bronze ASTM B584 Alloy C84400
2. Stem	Stainless Steel ASTM A582 Alloy C30300
3. Spring	316 Stainless Steel
4. Disc Holder	Stainless Steel Type 301
5. Disc	Water, Oil or Gas (Buna-N) Steam (PTFE) (Y)
6. Seat Screw	Stainless Steel ASTM A276 Alloy S43000
7. Body End	Bronze ASTM B584 Alloy C84400



**T-480**  
Threaded

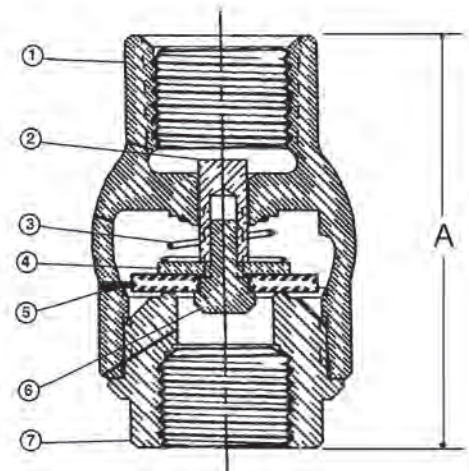

**T-480**  
NPT x NPT

## DIMENSIONS—WEIGHTS—QUANTITIES

Size	Dimensions						T-480		Master Ctn. Qty.	
	A		B		C		In.	mm.		
In.	mm.	In.	mm.	In.	mm.	In.	mm.	In.	mm.	
3/8	10	2.00	51	1.38	35	1.44	37	0.41	0.19	100
1/2	15	2.06	52	1.38	35	1.19	30	0.36	0.16	100
3/4	20	2.25	57	1.63	41	1.31	33	0.48	0.22	100
1	25	2.63	67	2.00	51	1.50	38	0.77	0.35	50
1 1/4	32	2.94	75	2.38	60	1.69	43	1.14	0.51	30
1 1/2	40	3.31	84	2.75	70	2.00	51	1.63	0.74	30
2	50	3.69	94	3.38	86	2.31	59	2.27	1.03	10

Ordering: The T-480 has standard Buna-N Discs.

Also available with PTFE (Y) Discs; specify T-480-Y.

3/8" thru 2" require 1/2 pound pressure to open.

NIBCO check valves may be installed in both horizontal and vertical lines with upward flow or in any intermediate position.

**WARNING** - Valve must be installed downstream of receiver tank if used in line with reciprocating air compressor.

Do Not Use as a Footvalve.

Warning – Do Not Use For Reciprocating Air Compressor Service.

**WARNING:** This product can expose you to chemicals including lead, which is known to the State of California to cause cancer and birth defects or other reproductive harm. For more information go to [www.P65Warnings.ca.gov](http://www.P65Warnings.ca.gov).

Visit our website for the most current information.

# 600 PSI WWP Bronze Ball Valves

Fire Protection Valve • Two-Piece Body • Chrome Plated Ball •  
Blowout-Proof Stem • Reinforced PTFE Seats • Full Port



**600 PSI/41.4 Bar Non-Shock Cold Water**

CONFORMS TO MSS SP-110

## MATERIAL LIST

PART	SPECIFICATION
1. Handle Nut	Zinc Plated Steel
2. Handle	Zinc Plated Steel Clear Chromate Plastisol Coated
3. Threaded Pack Gland	Brass ASTM B16 Alloy C36000
4. Packing	PTFE
5. Stem	Silicon Bronze ASTM B371 Alloy C69430 or ASTM B99 Alloy C65100
6. Thrust Washer	Reinforced PTFE
7. Ball	Brass ASTM B124 Alloy C37700 or ASTM B16 Alloy C36000 EACH with Hard Chrome Plate
8. Seat Ring (2)	Reinforced PTFE
9. Body	Cast Red Bronze ASTM B584 Alloy C84400
10. Body End Piece	Cast Red Bronze ASTM B584 Alloy C84400

¼" and ¾" size only has A304 stainless steel grounding washer.



**T-585-70**  
Threaded

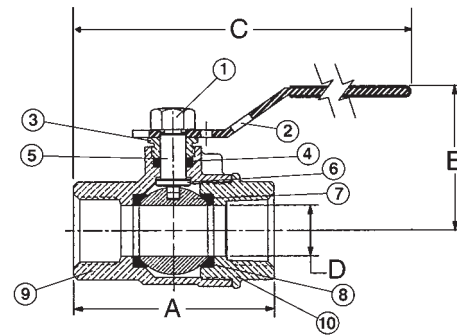

**T-585-70**  
NPT x NPT

## DIMENSIONS—WEIGHTS—QUANTITIES

Size	Dimensions								Weight	Box Qty.	Master Ctn. Qty.	
	A		B		C		D Port					Lbs.
In. mm.	In.	mm.	In.	mm.	In.	mm.	In.	mm.	In.	mm.		
¼ 8	2.00	51	1.75	44	5.00	127	.38	10	.45	.20	10	100
¾ 10	2.00	51	1.75	44	5.00	127	.38	10	.45	.20	10	100
½ 15	2.44	62	1.88	48	5.19	132	.50	13	.64	.29	10	100
¾ 20	2.94	75	2.25	57	6.25	159	.75	19	1.33	.60	5	50
1 25	3.34	85	2.38	60	6.44	164	1.00	25	1.79	.81	5	20
1¼ 32	4.19	106	3.00	76	6.75	171	1.25	32	2.17	.99	5	20
1½ 40	4.72	120	3.16	80	9.06	230	1.25	32	3.27	1.49	5	10
2 50	5.16	131	3.50	89	9.25	235	2.00	51	5.09	2.31	2	8

**WARNING:** This product can expose you to chemicals including lead, which is known to the State of California to cause cancer and birth defects or other reproductive harm. For more information go to [www.P65Warnings.ca.gov](http://www.P65Warnings.ca.gov).

Visit our website for the most current information.

## 300 PSI WWP Bronze Ball Valves

Fire Protection Valve • Two-Piece Body • Chrome Plated Ball •  
Blowout-Proof Stem • Reinforced PTFE Seats

**300 PSI/20.7 Bar Non-Shock Cold Water**

CONFORMS TO MSS SP-110 • UL 258 LISTED† •  
FM APPROVED†



### MATERIAL LIST

PART	SPECIFICATION
1. Handle Nut	Zinc Plated Steel
2. Handle	Zinc Plated Steel Clear Chromate with Plastisol Grip
3. Threaded Pack Gland	Brass ASTM B16
4. Packing	PTFE
5. Stem	Silicon Bronze ASTM B371 Alloy C69430 or ASTM B99 Alloy C65100
6. Thrust Washer	Reinforced PTFE
7. Ball	Brass ASTM B124 Alloy C37700 or ASTM B16 Alloy C36000 with Hard Chrome Plate
8. Seat Ring (2)	Reinforced PTFE
9. Body	Cast Red Bronze ASTM B584 Alloy C84400
10. Body End Piece	Cast Red Bronze ASTM B584 Alloy C84400

¼" and ¾" size only has A304 stainless steel grounding washer.



### KT-585-70-UL

¼" - 1" Full Port  
Threaded

### KT-580-70-UL

1¼" - 2" Standard Port  
Threaded

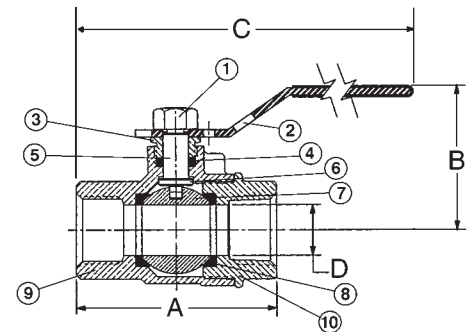

**KT-585-70-UL**  
Full Port  
NPT x NPT

**KT-580-70-UL**  
Standard Port  
NPT x NPT

### DIMENSIONS—WEIGHTS—QUANTITIES

KT-585-70-UL Dimensions													
Size	A		B		C		D Port		Weight		Box Qty.	Master Ctn. Qty.	
In. mm.	In.	mm.	In.	mm.	In.	mm.	In.	mm.	Lbs.	Kg.			
¼	8	2.00	51	1.75	44	5.00	127	.38	10	.45	.20	10	100
¾	10	2.00	51	1.75	44	5.00	127	.38	10	.45	.20	10	100
½	15	2.44	62	1.88	48	5.19	132	.50	13	.64	.29	10	100
¾	20	2.94	75	2.25	57	6.25	159	.75	19	1.33	.60	5	50
1	25	3.34	85	2.38	59	6.44	164	1.00	25	1.79	.81	5	20

KT-580-70-UL Dimensions													
Size	A		B		C		D Port		Weight		Box Qty.	Master Ctn. Qty.	
In. mm.	In.	mm.	In.	mm.	In.	mm.	In.	mm.	Lbs.	Kg.			
1 ¼	32	3.94	100	2.63	67	6.75	171	1.00	25	2.17	.99	5	20
1 ½	40	4.31	110	3.00	76	8.91	228	1.25	32	3.27	1.49	5	20
2	50	4.63	117	3.25	83	9.06	230	1.50	38	5.09	2.31	5	10
*2 ½	65	5.84	148	3.53	90	9.66	245	2.00	51	8.25	3.79	2	6
*3	80	7.09	202	4.41	112	11.53	293	2.50	64	15.65	7.11	1	4

† UL Listed, FM Approved for trim and drain use (UL Subject 258) – 585-70-UL ¼" thru 1" – 580-70-UL 1¼" thru 2".













\*2½"-3" supplied as T-580-70-UL subject to AHJ approval.

**DO NOT USE FOR NATURAL GAS**

**⚠ WARNING:** This product can expose you to chemicals including lead, which is known to the State of California to cause cancer and birth defects or other reproductive harm. For more information go to [www.P65Warnings.ca.gov](http://www.P65Warnings.ca.gov).

Visit our website for the most current information.

# UL/FM Iron Valve Illustrated Index

<p>UL/ULC Listed • FM Approved Iron Body Gate Valve Outside screw and yoke Rising stem, solid wedge 175 PSI WWP</p>  <p><b>F-607-OTS</b> Sizes 2 1/2" thru 12" Flanged ends <b>Page 19</b></p>	<p>UL/ULC Listed • FM Approved DI Body Gate Valve Rising stem, solid resilient wedge Outside screw and yoke 300 PSI WWP</p>  <p><b>F-607-RWS</b> (Flanged) <b>F-607-RWSB</b> (Flanged) Sizes 2 1/2" thru 16" <b>Page 20, 21</b></p>	<p>UL/ULC Listed • FM Approved Iron Body Gate Valve Indicator post pattern non-rising stem 175 PSI WWP</p>  <p><b>M-609</b> (Mechanical) <b>F-609</b> (Flanged) Sizes 4" thru 12" <b>Page 22</b></p>	<p>UL/ULC Listed • FM Approved DI Body Gate Valve (Resilient Wedge) Indicator post pattern Non-rising stem 300 PSI WWP</p>  <p><b>M-609-RWS</b> (Mechanical) <b>F-609-RWS</b> (Flanged) Sizes 4" thru 16" <b>Page 23</b></p>
<p>UL/ULC Listed • FM Approved DI Body Gate Valve Non-rising stem, resilient wedge 300 PSI WWP</p>  <p><b>FM609-RWS</b> Sizes 4" thru 12" Flanged x Mechanical <b>Page 24</b></p>	<p>UL/ULC Listed • FM Approved Gate Valve Indicator Post</p>  <p><b>NIP-1AU</b> Upright Indicator Post <b>Page 25 - 26</b></p>	<p>UL/ULC Listed • FM Approved Gate Valve Indicator Post</p>  <p><b>NIP-2AW</b> Wall Indicator Post <b>Page 27</b></p>	<p>UL/ULC Listed • FM Approved Iron Body Silent Check Valve Twin Disc, Spring Actuated Nitrile Rubber Seat 250 PSI WWP</p>  <p><b>KG-900-W-LF</b> Sizes 2 1/2" thru 12" Grooved <b>Page 28</b></p>
<p>UL/ULC Listed Iron Body Silent Check Valve Twin Disc, Spring Actuated Nitrile Rubber Seat 350 PSI WWP</p>  <p><b>KG-900-W-LF 350</b> Sizes 2 1/2", 3", 4", 6", 8", 10" Grooved <b>Page 29</b></p>	<p>UL/ULC Listed • FM Approved Iron Body Check Valve Double-Door Style, Spring Actuated Nitrile Rubber Seat 250 PSI WWP</p>  <p><b>KW-900-W-LF</b> Sizes 2 1/2" thru 16" Wafer Style <b>Page 30</b></p>	<p>UL/ULC Listed • FM Approved Iron Body Swing Check Valve Rubber Disc 175 PSI WWP</p>  <p><b>F-908-W</b> Sizes 2 1/2" thru 12" Flanged ends <b>Page 31</b></p>	<p>UL/ULC Listed • FM Approved Iron Body Swing Check Valve 250 PSI WWP</p>  <p><b>G-917-W</b> Sizes 2 1/2" thru 6" Grooved ends <b>Page 32</b></p>
<p>UL/ULC Listed • FM Approved Iron Body Swing Check Valve 300 PSI WWP</p>  <p><b>G-997</b> Sizes 2" thru 12" Grooved ends <b>Page 33</b></p>			

Visit our website for the most current information.

## 175 PSI WWP Iron Body Gate Valves

Fire Protection Valve • Bolted Bonnet • Outside Screw and Yoke • Solid Wedge •  
Pre-Grooved Stem for Supervisory Switch Mounting



### 175 PSI/12.1 Bar Non-Shock Cold Water

CONFORMS TO MSS SP-70 •

UL/ULC LISTED\* • FM APPROVED •

APPROVED BY THE NEW YORK CITY B.S.A. 143-69-SA

#### MATERIAL LIST

PART	SPECIFICATION
1. Stem	Copper Alloy, ASTM B16 C36000
2. Nut, Handwheel	Cast Copper Alloy, ASTM B584 C84400
3. Handwheel, Orange	Cast Iron, ASTM A126-B
4. Bushing, Yoke	Cast Copper Alloy, ASTM B584 C84400
5. Screw, Hex - Bonnet Cap	Steel, ASTM A307 / SAE J429
6. Cap, Bonnet	Ductile Iron ASTM A536
7. Nut, Square - Bonnet Cap	Steel, ASTM A563
8. Bonnet <sup>1</sup>	Cast Iron, ASTM A126-B
9. Nut, Heavy Hex - Gld Follow	Stainless Steel, ASTM A240
10. Gland Follower	Ductile Iron ASTM A536
11. Pack Gland	Powdered Metal ASTM B783
12. Pack Ring	Aramid Fiber / Graphite
13. Bolt, Sq Head - Gld Follow	Steel, ASTM A307 / SAE J429
14. Screw, Hex - Body	Steel, ASTM A307 / SAE J429
15. Gasket, Body	Synthetic Fiber / Nitrile
16. Nut, Hex - Body	Steel, ASTM A563
17. Collar, Stem	Copper Alloy, ASTM B16 C36000
18. Pin, Wedge	Copper Alloy, ASTM B140 C31600
19. Ring, Seat - Wedge	Cast Copper Alloy, ASTM B584 C84400
20. Wedge <sup>2</sup>	Cast Iron, ASTM A126-B
21. Ring, Seat - Body	Cast Copper Alloy, ASTM B584 C84400
22. Body	Cast Iron, ASTM A126-B

<sup>1</sup> Sizes thru 8", Yoke and Bonnet are intergral. 10" and 12" sizes separate Yoke is bolted to Bonnet.

<sup>2</sup> Sizes 2½" thru 6" have Cast Copper Alloy Wedges.

Sizes 8" thru 12" made with Cast Iron Wedge with Cast Copper Alloy Face Rings.

TS: Pre-grooved Stem for Supervisory Switch Activation.

NOTE: 1. Valve Flanges per ASME B16.1, Class 125

2. NIBCO may substitute Ductile Iron ASTM A395 (60-40-18) for ASTM A126 Class B Cast Iron for the Body, Bonnet, Wedge, or Disc. NIBCO may substitute Ductile Iron ASTM A395 (60-40-18) or ASTM A536 (65-45-12) for all other ASTM A126 Class B Cast Iron components.

\* Compliance with the Standard for Gate Valves for Fire Protection Service, UL 262, and the Canadian Requirements.

#### DIMENSIONS—WEIGHTS—QUANTITIES

Size	Dimensions										Weight		
	A		B		C		D		E		Lbs.	Kg.	
In. mm.	In.	mm.	In.	mm.	In.	mm.	In.	mm.	In.	mm.			
2½	65	7.50	191	17.26	438	8.00	203	7.00	178	0.69	18	55	25
3	80	8.00	203	19.44	494	8.00	203	7.50	191	0.75	19	67	30
4	100	9.00	229	23.54	598	10.25	260	9.00	229	0.94	24	107	49
5	125	10.00	254	27.01	686	10.25	260	10.00	254	0.94	24	145	66
6	150	10.50	267	30.73	781	12.00	305	11.00	279	1.00	25	178	81
8	200	11.50	292	40.29	1023	14.00	356	13.50	343	1.12	28	309	140
10	250	13.00	330	48.45	1231	16.25	413	16.00	406	1.19	30	481	219
12	300	14.00	356	56.26	1429	18.00	457	19.00	483	1.25	32	706	321

**WARNING:** This product can expose you to chemicals including lead, which is known to the State of California to cause cancer and birth defects or other reproductive harm. For more information go to [www.P65Warnings.ca.gov](http://www.P65Warnings.ca.gov).



**F-607-OTS**

Flanged

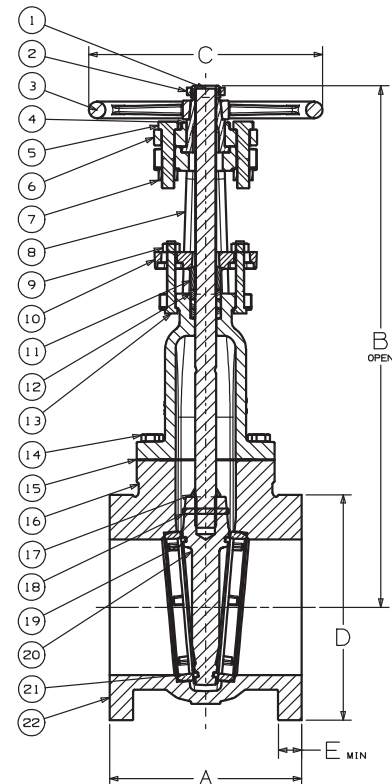

**F-607-OTS**

Flg x Flg

**FREEZING WEATHER PRECAUTION:** Subsequent to testing a piping system, gate valve should be in an open position to allow complete drainage.

Visit our website for the most current information.

# 300 PSI CWP Iron Body Gate Valves

Fire Protection Valve • Outside Screw and Yoke • **Resilient Wedge** • Epoxy Coated Interior/Exterior • Pre-Grooved Stem for Supervisory Switch • Drilled, Tapped and Plugged at Boss Location A\*\*



**300 PSI/20.6 Bar Non-Shock Cold Working Pressure**

UL/ULC LISTED† • FM APPROVED • CERTIFIED LEAD-FREE BY TRUESDAIL LABORATORIES TO NSF/ANSI/CAN 61 & 372



**F-607-RWS**  
Flanged

## MATERIAL LIST

PART	SPECIFICATION
1. Valve Body	Ductile Iron ASTM A536
2. Resilient Wedge	Ductile Iron ASTM A536/EPDM ASTM D2000
3. Wedge Nut	ASTM B584 UNS C83600
4. Dowel Pin	ASTM A276 SS304
5. Stem Back Seat O-Ring	EPDM ASTM D2000
6. Bonnet Gasket	EPDM ASTM D2000
7. Bonnet	Ductile Iron ASTM A536
8. Stem Packing	EPDM ASTM D2000
9. Threaded Rod	ASTM A276 SS304
10. Gland Bushing	ASTM B584 UNS C83600
11. Gland	Ductile Iron ASTM A536
12. Gland Nut	ASTM B148 C95200 Aluminum Bronze
13. Yoke	Ductile Iron ASTM A536
14. Yoke Bushing	ASTM B150 C61400
15. Flat Point Set Screw	ASTM F912M
16. Yoke Bushing Retainer	Cast Iron ASTM A126 Class B
17. Handwheel	Ductile Iron ASTM A536
18. Handwheel Nut	Carbon Steel Corrosion Resistant
19. Stem	Stainless Steel 304
20. Bonnet Screw	Corrosion-resistant Steel
21. NPT Pipe Plug	Steel ASME B16.14
22. UL/FM Label (not shown)	Aluminum
23. Yoke Screw	Steel Plated ASTM A307
24. Drive Screw Label (not shown)	Stainless Steel 304

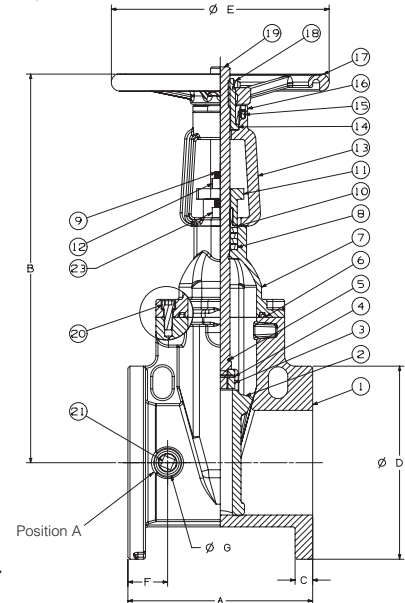

**F-607-RWS**  
Flg x Flg

Coating — Electrostatically applied fusion-bonded epoxy 8-20 mil. inside and outside meets or exceeds AWWA C550.

\*\*Drilled, tapped and plugged at Position A with 1/2" valve sizes 2 1/2"-4", 3/4" on 6"-8", 1" on 10"-16".

† Compliance with the Standard for Gate Valves for Fire Protection Service, UL 262, and the Canadian Requirements, ULC/ORD-C262.

NOTE: Flanged valve is consistent with ANSI B16.1 Class 125.

## DIMENSIONS—WEIGHTS—QUANTITIES

Size	Dimensions														Bolt Circle	Flange Holes	Turns to Open	Weight					
	A	B Open		B Closed		C		D		E		F		G				Lbs.	Kg.				
In.	mm.	In.	mm.	In.	mm.	In.	mm.	In.	mm.	In.	mm.	In.	mm.	In.	mm.	In.	mm.						
2 1/2	65	7.5	190	17.2	437	14.5	368	0.69	17.5	7.0	178	7.9	200	1.48	38	1.4	36	5.50	140	4	6.30	39	18
3	80	8.0	203	18.6	472	15.4	391	0.75	19.0	7.5	191	7.9	200	1.73	44	1.4	36	6.00	152	4	10.00	44	20
4	100	9.0	229	21.4	544	17.3	439	0.94	24.0	9.0	229	10.2	260	2.13	54	1.4	36	7.50	191	8	10.00	72	33
6	150	10.5	267	28.4	721	22.4	569	1.00	25.4	11.0	279	12.4	315	2.26	57	1.5	39	9.50	241	8	15.00	117	53
8	200	11.5	292	36.1	917	28.0	711	1.13	28.7	13.5	343	14.8	375	2.46	63	1.5	39	11.75	298	8	16.70	198	90
10	250	13.0	330	44.5	1130	34.4	874	1.19	30.2	16.0	406	16.4	416	3.15	80	1.8	46	14.25	362	12	20.80	374	170
12	300	14.0	356	51.7	1313	39.7	1008	1.25	31.8	19.0	483	17.5	445	2.91	74	1.8	46	17.00	432	12	25.00	493	224
14*	350	15.0	381	62.8	1595	50.0	1270	1.38	35.0	21.0	533	19.7	500	2.95	75	3.2	81	18.75	476	12	43.80	620	284
16*	400	16.0	406	66.5	1689	50.7	1288	1.44	37.0	23.5	597	19.7	500	3.03	77	3.2	81	21.25	540	16	50.00	816	370

\*14 and 16" valves 250 PSI CWP

**WARNING:** This product can expose you to chemicals including lead, which is known to the State of California to cause cancer and birth defects or other reproductive harm. For more information go to [www.P65Warnings.ca.gov](http://www.P65Warnings.ca.gov).

**FREEZING WEATHER PRECAUTION:** Subsequent to testing a piping system, gate valve should be in an open position to allow complete drainage.

Visit our website for the most current information.

LEAD-FREE: Weighted average lead content <0.25%

# 300 PSI CWP Iron Body Gate Valves

Fire Protection Valve • Outside Screw and Yoke • Resilient Wedge • Epoxy Coated Interior/Exterior • Pre-Grooved Stem for Supervisory Switch • Boss Position A Not Tapped

**300 PSI/20.6 Bar Non-Shock Cold Working Pressure**

UL/ULC LISTED† • FM APPROVED • CERTIFIED LEAD-FREE BY TRUESDAIL LABORATORIES TO NSF/ANSI/CAN 61 & 372



**F-607-RWSB**  
Flanged

## MATERIAL LIST

PART	SPECIFICATION
1. Valve Body	Ductile Iron ASTM A536
2. Resilient Wedge	Ductile Iron ASTM A536/EPDM ASTM D2000
3. Wedge Nut	ASTM B584 UNS C83600
4. Dowel Pin	ASTM A276 SS304
5. Stem Back Seat O-Ring	EPDM ASTM D2000
6. Bonnet Gasket	EPDM ASTM D2000
7. Bonnet	Ductile Iron ASTM A536
8. Stem Packing	EPDM ASTM D2000
9. Threaded Rod	ASTM A276 SS304
10. Gland Bushing	ASTM B584 UNS C83600
11. Gland	Ductile Iron ASTM A536
12. Gland Nut	ASTM B148 C95200 Aluminum Bronze
13. Yoke	Ductile Iron ASTM A536
14. Yoke Bushing	ASTM B150 C61400
15. Flat Point Set Screw	ASTM F912M
16. Yoke Bushing Retainer	Cast Iron ASTM A126 Class B
17. Handwheel	Ductile Iron ASTM A536
18. Handwheel Nut	Carbon Steel Zinc Plated
19. Stem	Stainless Steel 304
20. Bonnet Screw	Corrosion-resistant Steel
21. Drive Screw Label (not shown)	Stainless Steel 304
22. UL/FM Label (not shown)	Aluminum
23. Yoke Screw	Steel Plated ASTM A307

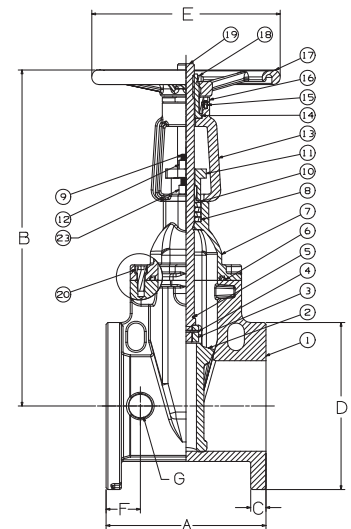

**F-607-RWSB**  
Flg x Flg

Coating — Electrostatically applied fusion-bonded epoxy 8-20 mil. inside and outside meets or exceeds AWWA C550.

† Compliance with the Standard for Gate Valves for Fire Protection Service, UL 262, and the Canadian Requirements, ULC/ORD-C262.

NOTE: Flanged valve is consistent with ANSI B16.1 Class 125.

## DIMENSIONS—WEIGHTS—QUANTITIES

Size	Dimensions												Bolt Circle	Flange Holes	Turns to Open	Weight				
	A	B Open		B Closed		C		D		E		F				G		Lbs.	Kg.	
In. mm.	In. mm.	In. mm.	In. mm.	In. mm.	In. mm.	In. mm.	In. mm.	In. mm.	In. mm.	In. mm.	In. mm.	In. mm.	In. mm.	In. mm.	In. mm.	In. mm.	In. mm.			
2½	65 7.5	190 17.8	453 14.9	378 15.9	0.69 0.75	17.5 19.0	7.0 7.5	178 191	7.9 7.9	200 200	1.50 1.73	38 44	1.42 1.42	36 36	5.50 6.00	140 152	4 4	6.3 10.0	39 44	18 20
3	80 8.0	203 19.7	500 15.9	405 15.9	0.75 0.94	19.0 24.0	7.5 9.0	191 229	7.9 10.2	200 260	1.73 2.13	44 54	1.42 1.42	36 36	6.00 7.50	152 191	4 8	10.0 10.0	44 72	18 33
4	100 9.0	229 21.0	534 16.6	422 16.6	0.94 1.00	24.0 25.4	9.0 11.0	229 279	12.4 12.4	260 315	2.13 2.24	54 57	1.42 1.54	36 39	7.50 9.50	191 241	8 8	10.0 15.0	72 117	33 53
6	150 10.5	267 29.3	744 22.9	581 22.9	1.00 1.13	25.4 28.6	11.0 13.5	279 343	12.4 14.8	315 375	2.24 2.48	57 63	1.54 1.54	39 39	9.50 11.75	241 298	8 8	15.0 16.7	117 198	53 90
8	200 11.5	292 37.0	939 28.5	724 28.5	1.13 1.19	28.6 30.2	13.5 16.0	343 406	14.8 16.4	375 416	2.48 3.15	63 80	1.54 1.82	39 46	11.75 14.25	298 362	8 12	16.7 20.8	198 374	90 170
10	250 13.0	330 44.8	1139 34.5	877 34.5	1.19 1.25	30.2 31.8	16.0 19.0	406 483	16.4 17.5	416 445	3.15 2.91	80 74	1.82 1.82	46 46	14.25 17.00	362 432	12 12	20.8 25.0	374 493	170 224
12	300 14.0	356 52.2	1326 39.9	1014 39.9	1.25 1.38	31.8 35.0	19.0 21.0	483 533	17.5 19.7	445 500	2.91 2.95	74 75	1.82 3.20	46 81	17.00 18.75	432 476	12 12	25.0 43.8	493 620	224 284
14*	350 15.0	375 62.2	1580 50.0	1270 50.0	1.38 1.44	35.0 37.0	21.0 23.5	533 597	19.7 19.7	500 500	2.95 3.03	75 77	3.20 3.20	81 81	18.75 21.25	476 540	12 16	43.8 50.0	620 816	284 370
16*	400 16.0	400 65.9	1674 50.4	1280 50.4	1.44 1.44	37.0 37.0	23.5 23.5	597 597	19.7 19.7	500 500	3.03 3.03	77 77	3.20 3.20	81 81	21.25 21.25	540 540	16 16	50.0 50.0	816 816	370 370

\*14 and 16" valves 250 PSI CWP

**WARNING:** This product can expose you to chemicals including lead, which is known to the State of California to cause cancer and birth defects or other reproductive harm. For more information go to [www.P65Warnings.ca.gov](http://www.P65Warnings.ca.gov).

**FREEZING WEATHER PRECAUTION:** Subsequent to testing a piping system, gate valve should be in an open position to allow complete drainage.

LEAD-FREE: Weighted average lead content <0.25%

Visit our website for the most current information.

# 175 PSI WWP Iron Body Gate Valves

Fire Protection Post Indicator Valve • Bolted Bonnet • Indicator Post Pattern  
• Non-Rising Stem • Solid Wedge



## 175 PSI/12.1 Bar Non-Shock Cold Water

UL/ULC LISTED • FM APPROVED

### MATERIAL LIST

PART	SPECIFICATION
1. Nut	Steel ASTM A307
2. Square Oper. Nut	Cast Iron ASTM A126 Class B
3. Stem	Brass ASTM B16 Alloy C36000
4. Ind. Post Flange Nut	Steel ASTM A307
5. Ind. Post Flange	Cast Iron ASTM A126 Class B
6. Ind. Post Flange Bolt	Steel ASTM A307
7. O-Ring Seal	Buna-N Rubber
8. Bonnet	Cast Iron ASTM A126 Class B
9. Ind. Post Flange Gasket	Aramid Fiber / Graphite
10. Body Bolt	Steel ASTM A307
11. Body Gasket	Aramid Fiber/Graphite
12. Body Nut	Steel ASTM A307
13. Body	Cast Iron ASTM A126 Class B
14. Wedge Bushing*	Cast Bronze B584 Alloy C84400
15. Wedge	Cast Iron ASTM A126 Class B
16. Wedge Face Ring	Cast Bronze B584 Alloy C84400
17. Seat Ring	Cast Bronze B584 Alloy C84400



**F-609**  
Flanged

**M-609**  
Mechanical

**NOTE:** 1. Flanged valve is consistent with ANSI B16.1 Class 125.  
2. Post Flange has a 12 OD and 10.5" bolt circle.  
3. NIBCO may substitute Ductile Iron ASTM A395 (60-40-18) for ASTM A126 Class B Cast Iron for the Body, Bonnet, Wedge, or Disc. NIBCO may substitute Ductile Iron ASTM A395 (60-40-18) or ASTM A536 (65-45-12) for all other ASTM A126 Class B Cast Iron components.  
\* Compliance with the Standard for Gate Valves for Fire Protection Service, UL 262, and the Canadian Requirements, ULC/ORD-C262.

### DIMENSIONS—WEIGHTS—QUANTITIES

Size	F-609 Dimensions										Weight		
	A		B		C		D		E		Lbs.	Kg.	
In. mm.	In.	mm.	In.	mm.	In.	mm.	In.	mm.	In.	mm.			
4	100	9.00	229	14.13	359	9.00	229	.94	24	3.66	93	105	48
6	150	10.50	267	18.56	471	11.00	279	1.00	25	3.44	87	170	77
8	200	11.50	292	22.13	562	13.50	343	1.13	29	4.00	102	277	125
10	250	13.00	330	25.75	654	16.00	406	1.19	30	3.88	98	399	181
12	300	14.00	356	29.50	749	19.00	483	1.25	32	4.94	125	623	283

Size	M-609 Dimensions										Weight		
	A		B		C		D		E		Lbs.	Kg.	
In. mm.	In.	mm.	In.	mm.	In.	mm.	In.	mm.	In.	mm.			
4	100	9.25	235	14.13	359	9.00	229	1.00	25	3.66	93	100	45
6	150	10.75	273	18.56	471	11.09	282	1.03	26	3.44	87	153	69
8	200	11.50	292	22.13	562	13.31	338	1.09	28	4.00	102	250	113
10	250	13.00	330	25.75	654	15.63	397	1.13	29	3.88	98	390	176
12	300	14.00	356	29.50	749	18.00	457	1.25	32	4.94	125	556	253

**FREEZING WEATHER PRECAUTION:** Subsequent to testing a piping system, gate valve should be in an open position to allow complete drainage.

**NOTE:** Number of turns required to open 4", 9", 6", 13½", 8", 17½", 10", 30¼", 12", 38¾" turns.  
Tolerance ± ½ turn on all sizes.

**NOTE:** Available to ISO Flange dimensions. Specify F-609-I.

**WARNING:** This product can expose you to chemicals including lead, which is known to the State of California to cause cancer and birth defects or other reproductive harm. For more information go to [www.P65Warnings.ca.gov](http://www.P65Warnings.ca.gov).

Visit our website for the most current information.

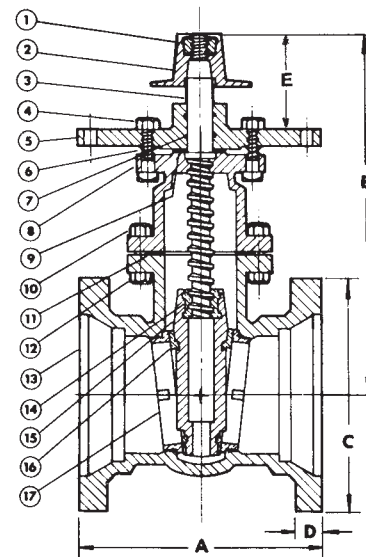

**M-609**  
MJ x MJ

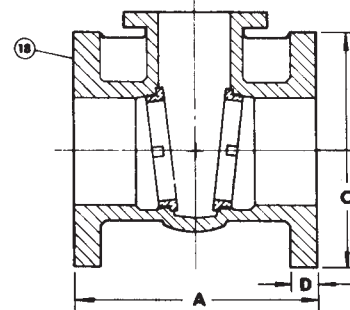

**F-609**  
Flg x Flg

## 300 PSI CWP Iron Body Gate Valves

Fire Protection Post Indicator Valve • Bolted Bonnet • Indicator Post Pattern • Non-Rising Stem • Resilient Wedge • Epoxy Coated Interior/Exterior



### 300 PSI/20.6 Bar Non-Shock Cold Working Pressure

UL/ULC LISTED • FM APPROVED • CERTIFIED LEAD-FREE BY TRUESDAIL LABORATORIES TO NSF/ANSI/CAN 61 & 372



#### MATERIAL LIST

PART	SPECIFICATION
1 Valve Body	Ductile Iron ASTM A536
2 Resilient Wedge	Ductile Iron ASTM A536 / EPDM ASTM D2000
3 Wedge Nut	ASTM B584 UNS C83600
4 Stem	Stainless Steel 304
5 Bonnet Gasket	EPDM ASTM D2000
6 Bonnet Screw	Corrosion-resistant Steel
7 Bonnet	Ductile Iron ASTM A536
8 Stem Primary O-Ring	EPDM ASTM D2000
9 Stem Thrust Washer (lower)	Bronze ASTM B584 UNS C83600
10 Stem Thrust Washer (upper)	Stainless Steel ASTM A276 UNS S41000
11 Gland Seal O-Ring	EPDM ASTM D2000
12 Stem Seal Bushing	ASTM B584 UNS C83600
13 Stem Secondary O-Ring	EPDM ASTM D2000
14 Gland Flange	Ductile Iron ASTM A536
15 Stem Ring Wiper	EPDM ASTM D2000
16 Square Operating Nut	Cast Iron ASTM A126-B
17 Operating Nut Washer	ASTM A276 SS304
18 Operating Nut Screw	Alloy Steel ASTM A574M Zinc Plated
19 Gland Flange Screw	Alloy Steel ASTM A574M Zinc Plated
20 Indicator Flange Screw	Alloy Steel ASTM A574M Zinc Plated
21 Indicator Post Flange	Cast Iron ASTM A126-B
22 UL/FM Label (not shown)	Aluminum
23 Drive Screw, Label (not shown)	Stainless Steel 304



**F-609-RWS**  
Flanged



**M-609-RWS**  
Mechanical

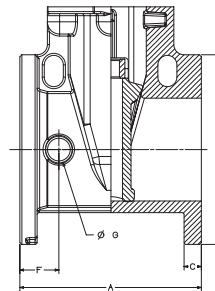

**F-609-RWS**  
Flg x Flg

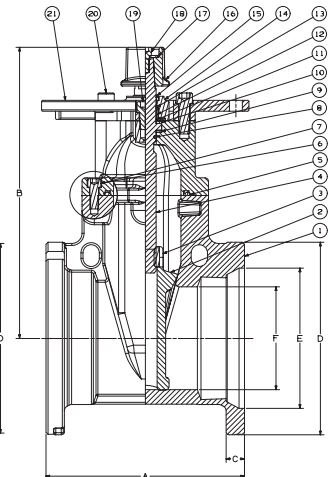

**M-609-RWS**  
MJ x MJ

Coating — Electrostatically applied fusion-bonded epoxy 8-20 mil. inside and outside meets or exceeds AWWA C550.

NOTE: Flanged valve is consistent with ANSI B16.1 Class 125.

#### DIMENSIONS—WEIGHTS—QUANTITIES

Size	M-609-RWS Dimensions						Bolt				Weight	
	A	B	C	D	E	F	Circle	Flange	Turns			
In. mm.	In. mm.	In. mm.	In. mm.	In. mm.	In. mm.	In. mm.	In. mm.	In. mm.	Holes	To Open	Lbs.	Kg.
4 100	10.0 254	13.4 340	1.00 25	9.1 232	6.02 153	3.98 100	7.50 191	4	12.5	72	33	
6 150	11.5 292	16.9 429	1.06 27	11.1 283	8.12 206	5.96 150	9.50 241	6	15.0	101	46	
8 200	11.5 292	20.6 523	1.13 29	13.4 340	10.27 261	7.91 200	11.75 298	6	16.7	148	67	
10 250	13.0 330	23.7 602	1.19 30	15.6 397	12.34 313	9.90 250	14.00 356	8	20.8	236	107	
12 300	14.0 356	27.1 688	1.25 32	18.0 456	14.44 367	11.81 300	16.25 413	8	25.0	353	160	

Size	F-609-RWS Dimensions						Bolt				Weight	
	A	B	C	D	F	G	Circle	Flange	Turns			
In. mm.	In. mm.	In. mm.	In. mm.	In. mm.	In. mm.	In. mm.	In. mm.	In. mm.	Holes	To Open	Lbs.	Kg.
4 100	9.0 229	13.4 340	0.94 23.9	9.0 229	2.13 54	1.4 36	7.50 191	8	12.5	75	34	
6 150	10.5 267	16.9 429	1.00 25.4	11.0 279	2.26 57	1.5 39	9.50 241	8	15.0	106	48	
8 200	11.5 292	20.6 523	1.13 28.7	13.5 343	2.46 62	1.5 39	11.75 298	8	16.7	163	74	
10 250	13.0 330	23.7 602	1.19 30.2	16.0 406	3.15 80	1.8 46	14.25 362	12	20.8	256	116	
12 300	14.0 356	27.1 688	1.25 31.8	19.0 483	2.91 74	1.8 46	17.00 432	12	25.0	394	181	
14 350	15.0 381	31.7 805	1.38 35.0	21.0 533	2.95 75	3.2 80	18.75 476	12	43.8	625	284	
16 400	16.0 406	34.1 866	1.50 38.0	23.5 597	3.07 78	3.2 80	21.25 540	16	50.0	825	375	

**FREEZING WEATHER PRECAUTION:** Subsequent to testing a piping system, gate valve should be in an open position to allow complete drainage.



**WARNING:** This product can expose you to chemicals including lead, which is known to the State of California to cause cancer and birth defects or other reproductive harm. For more information go to [www.P65Warnings.ca.gov](http://www.P65Warnings.ca.gov).

LEAD-FREE: Weighted average lead content <0.25%

Visit our website for the most current information.

# 300 PSI CWP Iron Body Gate Valves

Fire Protection Post Indicator Valve • Bolted Bonnet • Indicator Post Pattern •  
Non-Rising Stem • Resilient Wedge • Epoxy Coated Interior/Exterior

**300 PSI/20.6 Bar Non-Shock Cold Working Pressure**  
**(160° F/71° C max. operating temperature)**

UL/ULC LISTED • FM APPROVED • CERTIFIED LEAD-FREE BY  
TRUESDAIL LABORATORIES TO NSF/ANSI/CAN 61 & 372



**FM609-RWS**  
Flanged x Mechanical Joint

## MATERIAL LIST

PART	SPECIFICATION
1 Valve Body	Ductile Iron ASTM A536
2 Resilient Wedge	Ductile Iron ASTM A536 / EPDM ASTM D2000
3 Wedge Nut	ASTM B584 UNS C83600
4 Stem	Stainless Steel 304
5 Bonnet Gasket	EPDM ASTM D2000
6 Bonnet Screw	Corrosion-resistant Steel
7 Bonnet	Ductile Iron ASTM A536
8 Stem Primary O-Ring	EPDM ASTM D2000
9 Stem Thrust Washer (lower)	Bronze ASTM B584 UNS C83600
10 Stem Thrust Washer (upper)	Stainless Steel ASTM A276 UNS S41000
11 Gland Seal O-Ring	EPDM ASTM D2000
12 Stem Seal Bushing	ASTM B584 UNS C83600
13 Stem Secondary O-Ring	EPDM ASTM D2000
14 Gland Flange	Ductile Iron ASTM A536
15 Stem Ring Wiper	EPDM ASTM D2000
16 Square Operating Nut	Cast Iron ASTM A126-B
17 Operating Nut Washer	ASTM A276 SS304
18 Operating Nut Screw	Alloy Steel ASTM A574M Zinc Plated
19 Gland Flange Screw	Alloy Steel ASTM A574M Zinc Plated
20 Indicator Flange Screw	Alloy Steel ASTM A574M Zinc Plated
21 Indicator Post Flange	Cast Iron ASTM A126-B
22 UL/FM Label (not shown)	Aluminum
23 Drive Screw, Label (not shown)	Stainless Steel 304

Coating — Electrostatically applied fusion-bonded epoxy 8-20 mil. inside and outside meets or exceeds AWWA C550.

NOTE: Flanged valve is consistent with ANSI B16.1 Class 125.

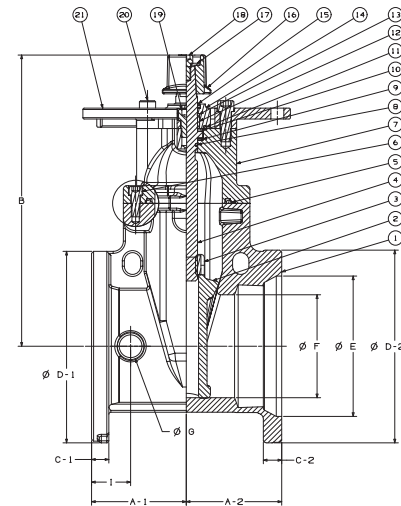

**FM609-RWS**  
Flg x MJ

## DIMENSIONS—WEIGHTS—QUANTITIES

Size	Dimensions																
	A-1		A-2		B		C-1		C-2		D-1		D-2		E		F
In. mm.	In. mm.	In. mm.	In. mm.	In. mm.	In. mm.	In. mm.	In. mm.	In. mm.	In. mm.	In. mm.	In. mm.	In. mm.	In. mm.	In. mm.	In. mm.	In. mm.	In. mm.
4	100	4.75 121	4.75 121	13.4 339	0.94 24	1.00 25	9.0 229	9.1 232	6.02 153	3.98 100							
6	150	5.50 140	5.50 140	16.9 428	1.00 25	1.06 27	11.0 279	11.1 282	8.12 206	5.96 150							
8	200	5.75 146	5.75 146	20.4 517	1.13 29	1.13 29	13.5 343	13.4 340	10.27 261	7.91 200							
10	250	6.50 165	6.50 165	23.7 603	1.19 30	1.19 30	16.0 406	15.6 397	12.34 313	9.90 250							
12	300	7.00 178	7.00 178	27.1 688	1.25 32	1.25 32	19.0 483	17.9 454	14.44 367	11.81 300							

Size	G		I		Flanged B.C.		MJ B.C.		No. Holes		Turns		Weight	
	In. mm.	In. mm.	In. mm.	In. mm.	In. mm.	In. mm.	In. mm.	In. mm.	Flanged	M-Joint	To Open	Lbs.	Kg.	
4	100	1.4 36	2.13 54	7.50 191	7.50 191	8	4	12.5	72	33				
6	150	1.5 39	2.24 57	9.50 241	9.50 241	8	6	15.0	103	47				
8	200	1.5 39	2.48 63	11.75 296	11.75 298	8	6	16.7	99	45				
10	250	1.8 46	3.15 65	14.25 362	14.00 356	12	8	20.8	247	112				
12	300	1.8 46	2.91 74	17.01 432	16.25 413	12	8	25.0	377	171				

**FREEZING WEATHER PRECAUTION:**  
Subsequent to testing a piping system, gate valve should be in an open position to allow complete drainage.

**WARNING:** This product can expose you to chemicals including lead, which is known to the State of California to cause cancer and birth defects or other reproductive harm. For more information go to [www.P65Warnings.ca.gov](http://www.P65Warnings.ca.gov).

Visit our website for the most current information.

LEAD-FREE: Weighted average lead content <0.25%

# Upright Indicator Posts

PATENT #US 9,541,218

Fire Protection • Upright Style • For Use with Non-Rising Stem Indicator Post Style Gate Valves

UL/ULC LISTED • FM APPROVED



## MATERIAL LIST

PART	SPECIFICATION
1. Upper Body	Ductile Iron ASTM A536 Gr. 65-45-12
2. Cap	Ductile Iron ASTM A536 Gr. 65-45-12
3. T-Head Bolt, Cap (2)	Steel, Zinc Plated ASTM A105
4. Nut, Cap (2)	Steel, Zinc Plated ASTM A105
5. Operating Stem	Bronze ASTM B584 C84400 / B62 C83600
6. Retaining Ring	Stainless Steel ASTM A276 S30400
7. Leading Bogle	Bronze ASTM B584 C84400 / B62 C83600
8 Target Plate, OPEN (2)	Aluminum ASTM B26
9. Target Plate, SHUT (2)	Aluminum ASTM B26
10. Extension Plate (2)	Steel, Painted Black ASTM A1008
11. Target Rod (2)	Brass ASTM B16 C36000
12. View Window (2)	Polycarbonate Commercial
13. Gasket, Window (2)	Rubber ASTM D2000 EPDM
14. Guard, Window (2)	Cast Iron ASTM B124 Gr. B
19. Screw, Hex Head Cap (4)	Stainless Steel S30400
20. Washer (4)	Stainless Steel S30400
21. Screw, Slotted Flat Head (4)	Stainless Steel S30400
22. Plug, 1/2" Pipe	Steel, Zinc Plated Commercial
23. U-Bolt	Forged Steel ASTM A105
24. Cotter Pin	Stainless Steel S30400
25. Coupling, Operating Rod	Ductile Iron ASTM A536 Gr. 65-45-12
26. Operating Rod	Steel ASTM A105
28. Screw, Hex Head Cap	Stainless Steel S30400
29. Wrench, Operating	Ductile Iron ASTM A536 Gr. 65-45-12
30. Center Body	Ductile Iron ASTM A536 Gr. 65-45-12
31. Base Body	Ductile Iron ASTM A536 Gr. 65-45-12
32. Barrel	Ductile Iron ASTM A536 Gr. 65-45-12
33. Screw, Hex Head Cap (3)	Stainless Steel S30400
35. Screw, Hex Head Cap (2)	Stainless Steel S30400
37. Screw, Socket Head Set (6)	Stainless Steel S30400
38. Washer, Flat	Stainless Steel S30400
39. Washer, Lock	Stainless Steel S30400



**NIP-1AU**  
Upright  
Shown with  
post indicator  
valve

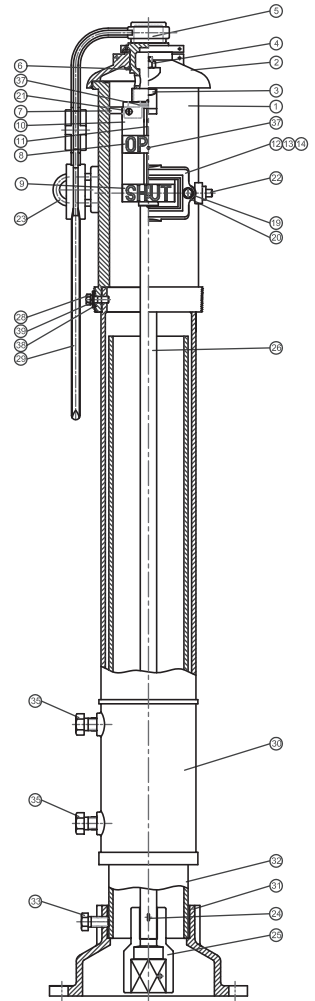

**NIP-1AU**

## DIMENSIONAL DATA FOR NIBCO RWGV AND IBBM GATE VALVES

Valve Size	NIBCO RESILIENT WEDGE GATE VALVES (RWGV)							NIBCO IRON BODY BRONZE MOUNTED GATE VALVES (IBBM)						
	TURNS TO OPEN	A		B		1/2 Pipe OD		TURNS TO OPEN	A		B		1/2 Pipe OD	
		In.	mm.	In.	mm.	In.	mm.		In.	mm.	In.	mm.	In.	mm.
4"	13	13.46	342	10.12	257	2.40	61	9	14.13	359	10.47	266	2.40	61
6"	15.7	17.01	432	13.78	350	3.45	88	13.5	18.54	471	16.30	414	3.45	88
8"	17.3	20.47	520	17.32	440	4.53	115	17.5	22.13	562	18.11	460	4.53	115
10"	21.4	23.82	605	20.71	526	5.50	140	30.3	25.75	654	21.89	556	5.50	140
12"	25.3	27.01	686	23.86	606	6.60	168	38.3	29.49	749	24.57	624	6.60	168
14"	44	31.81	808	28.58	726	7.65	194							
16"	50	34.21	869	30.98	787	8.70	221							

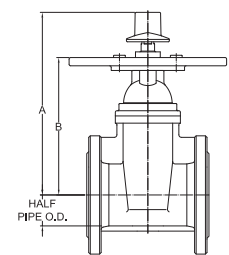
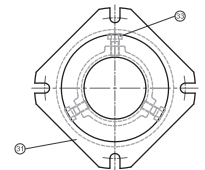

**WARNING:** This product can expose you to chemicals including lead, which is known to the State of California to cause cancer and birth defects or other reproductive harm. For more information go to [www.P65Warnings.ca.gov](http://www.P65Warnings.ca.gov).

Visit our website for the most current information.

# Upright Indicator Posts

## NIBCO UPRIGHT INDICATOR POST VALVE BURY DEPTH

Valve Size	Rounded Adjustable Bury Depth Range	NIBCO RESILIENT WEDGE GATE VALVES (RWGV)								NIBCO IRON BODY BRONZE MOUNTED GATE VALVES (IBBM)							
		NIP-1AU		NIP-1AU E		NIP-1AU EE		NIP-1AU EEE		NIP-1AU		NIP-1AU E		NIP-1AU EE		NIP-1AU EEE	
		Bury Depth		Bury Depth		Bury Depth		Bury Depth		Bury Depth		Bury Depth		Bury Depth		Bury Depth	
		In.	mm.	In.	mm.	In.	mm.	In.	mm.	In.	mm.	In.	mm.	In.	mm.	In.	mm.
4"	MINIMUM	28	724	46	1181	64	1638	82	2095	29	733	47	1190	65	1647	83	2104
	MAXIMUM	48	1232	66	1689	84	2146	102	2603	49	1241	67	1698	85	2155	103	2612
6"	MINIMUM	33	844	51	1301	69	1758	87	2215	36	908	54	1365	72	1822	90	2279
	MAXIMUM	53	1352	71	1809	89	2266	107	2723	56	1416	74	1873	92	2330	110	2787
8"	MINIMUM	38	961	56	1418	74	1875	92	2332	39	981	57	1438	75	1895	93	2352
	MAXIMUM	58	1469	76	1926	94	2383	112	2845	59	1489	77	1946	95	2403	113	2860
10"	MINIMUM	42	1072	60	1529	78	1986	96	2443	43	1102	61	1559	79	2016	97	2473
	MAXIMUM	62	1580	80	2037	98	2494	116	2951	63	1610	81	2067	99	2524	117	2981
12"	MINIMUM	46	1180	64	1637	82	2094	100	2551	47	1198	65	1655	83	2112	101	2569
	MAXIMUM	66	1688	84	2145	102	2602	120	3059	67	1706	85	2163	103	2620	121	3077
14"	MINIMUM	52	1326	70	1783	88	2240	106	2697								
	MAXIMUM	72	1834	90	2291	108	2748	126	3205								
16"	MINIMUM	56	1414	74	1871	92	2328	110	2785								
	MAXIMUM	76	1922	94	2379	112	2836	130	3293								

## NIBCO UPRIGHT INDICATOR POST ADJUSTABLE HEIGHT RANGE

Adjustable Height Range	NIP-1AU		NIP-1AU E		NIP-1AU EE		NIP-1AU EEE	
	H		H		H		H	
	In.	mm.	In.	mm.	In.	mm.	In.	mm.
MINIMUM	16	406	34	864	52	1321	70	1778
MAXIMUM	36	914	54	1372	72	1829	90	2286

### WEIGHTS\*

Fig. No.	Lbs.	KG
NIP-1AU	178	81
NIP-1AU E	204	93
NIP-1AU EE	230	104
NIP-1AU EEE	256	116

\* Includes rod and coupling

**WARNING:** This product can expose you to chemicals including lead, which is known to the State of California to cause cancer and birth defects or other reproductive harm. For more information go to [www.P65Warnings.ca.gov](http://www.P65Warnings.ca.gov).

Visit our website for the most current information.

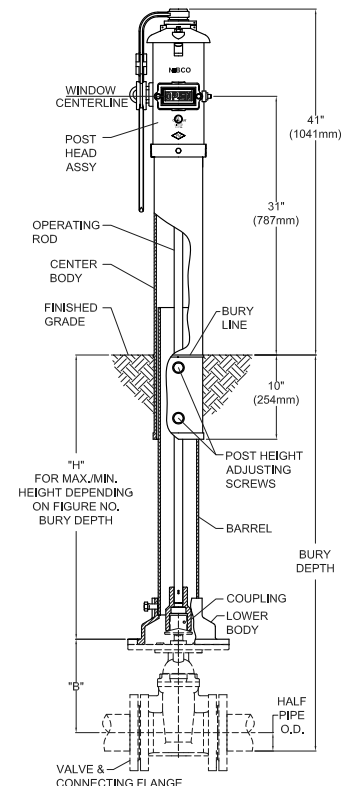

# Wall Mount Indicator Posts

PATENT #US 9,541,218

Fire Protection • Wall Mount Style • For Use with Non-Rising Stem Indicator Post Style Gate Valves



UL/ULC LISTED • FM APPROVED

## MATERIAL LIST

PART	SPECIFICATION
1. Upper Body	Ductile Iron ASTM A536 Gr. 65-45-12
2. Cap	Ductile Iron ASTM A536 Gr. 65-45-12
3. T-Head Bolt, Cap (2)	Zinc Plated Steel ASTM A105
4. Nut, Cap (2)	Zinc Plated Steel ASTM A105
5. Operating Stem	Bronze ASTM B584 C84400 / B62 C83600
6. Retaining Ring, Stem	Stainless Steel ASTM A276 S30400
7. Leading Bogie	Bronze ASTM B584 C84400 / B62 C83600
8. Target Plate, OPEN (2)	Aluminum ASTM B26
9. Target Plate, SHUT (2)	Aluminum ASTM B26
10. Extension Plate (2)	Steel, Painted Black ASTM A1008
11. Target Rod (2)	Brass ASTM B16 C36000
12. View Window (2)	Polycarbonate Commercial
13. Gasket, Window (2)	Rubber ASTM D2000 EPDM
14. Guard, Window (2)	Cast Iron ASTM B124 Gr. B
15. Handwheel	Ductile Iron ASTM A536 Gr. 65-45-12
16. Eyebolt, Handwheel	Zinc Plated Forged Steel ASTM A105
17. Washer, Handwheel Retainer	Zinc Plated Steel Commercial
19. Screw, Hex Head Cap (4)	Stainless Steel S30400
20. Washer (4)	Stainless Steel S30400
21. Screw, Slotted Flat Head (4)	Stainless Steel S30400
22. Plug 1/2" Pipe	Zinc Plated Steel Commercial
23. U-Bolt	Forged Steel ASTM A105
24. Cotter Pin	Stainless Steel S30400
25. Coupling, Operating Rod	Ductile Iron ASTM A536 Gr. 65-45-12
26. Operating Rod	Steel ASTM A105
27. Flange, Threaded	Ductile Iron ASTM A536 Gr. 65-45-12
37. Screw, Socket Head Set (6)	Stainless Steel S30400

## WEIGHT\*

Fig. No.	Lbs.	KG
NIP-2AW	89	40

\* Includes rod and coupling

\*\* Longer operating rods available. See installation operation guide on page 59.



**NIP-2AW**  
Wall Mount

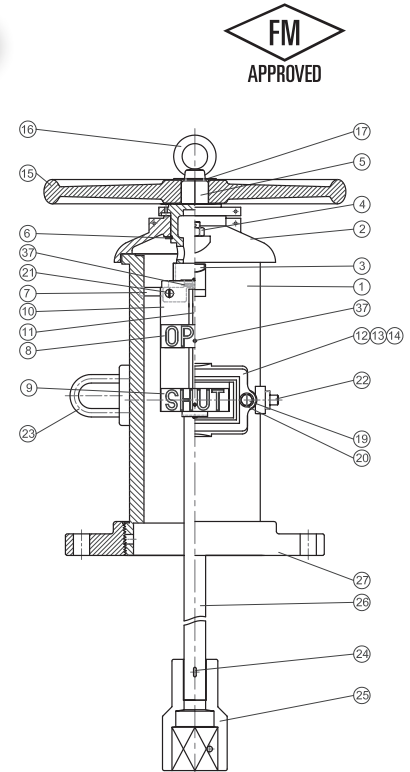

**NIP-2AW**

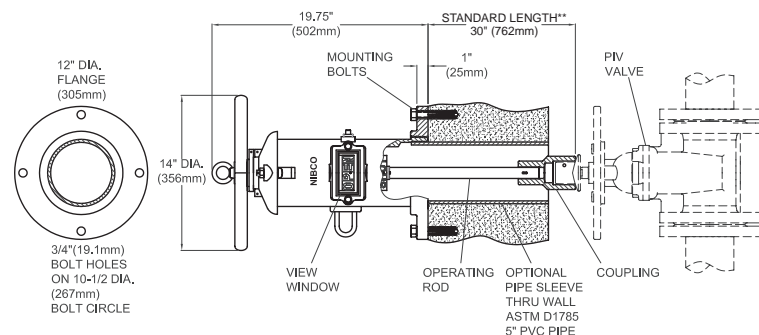

## DIMENSIONAL DATA FOR NIBCO RWGV AND IBBM GATE VALVES

Valve Size	NIBCO RESILIENT WEDGE GATE VALVES (RWGV)							NIBCO IRON BODY BRONZE MOUNTED GATE VALVES (IBBM)						
	TURNS TO OPEN	A		B		1/2 Pipe OD		TURNS TO OPEN	A		B		1/2 Pipe OD	
		In.	mm.	In.	mm.	In.	mm.		In.	mm.	In.	mm.	In.	mm.
4"	13	13.46	342	10.12	257	2.40	61	9	14.13	359	10.47	266	2.40	61
6"	15.7	17.01	432	13.78	350	3.45	88	13.5	18.54	471	16.30	414	3.45	88
8"	17.3	20.47	520	17.32	440	4.53	115	17.5	22.13	562	18.11	460	4.53	115
10"	21.4	23.82	605	20.71	526	5.50	140	30.3	25.75	654	21.89	556	5.50	140
12"	25.3	27.01	686	23.86	606	6.60	168	38.3	29.49	749	24.57	624	6.60	168
14"	44	31.81	808	28.58	726	7.65	194							
16"	50	34.21	869	30.98	787	8.70	221							

**WARNING:** This product can expose you to chemicals including lead, which is known to the State of California to cause cancer and birth defects or other reproductive harm. For more information go to [www.P65Warnings.ca.gov](http://www.P65Warnings.ca.gov).

Visit our website for the most current information.

# Lead-Free 250 PSI CWP Iron Body Grooved Silent Check Valves

Fire Protection • Twin Disc • Grooved Style • Bronze Disc • Nitrile • Spring Actuated

**250 PSI/17.2 Bar Non-Shock Cold Working Pressure**  
**Maximum Temperature to 180°F/82°C @ 220 PSI/15 Bar**

CERTIFIED LEAD-FREE BY WQA TO NSF/ANSI 372  
CONFORMS TO ANSI/AWWA C606 FOR STEEL IPS PIPE  
• UL/ULC LISTED • FM APPROVED



**C USA**  
**COMPONENT**  
**LEAD-FREE**



**KG-900-W-LF**  
Grooved

## MATERIAL LIST

PART	SPECIFICATION
1. Body	Ductile Iron ASTM A536 Grade 65-45-12 w/Buna-N (Nitrile) resilient seat molded to body
2. Disc	Bronze ASTM B584 Alloy C87600
3. Torsion Spring	Stainless Steel UNS 31600 ASTM A313
4. Disc Hinge Pin	Stainless Steel UNS 31600 ASTM A276
5. Disc Stop Pin	Stainless Steel UNS 31600 ASTM A276
6. Disc Thrust Bearing	Stainless Steel UNS 31600 ASTM A240
7. Hinge Pin Retainer	Stainless Steel UNS 31600
8. Stop Pin Retainer	Stainless Steel UNS 31600
9. Stabilization Sphere	Buna-N
10. Spacer	Stainless Steel UNS 31600 ASTM A276

Sizes 10" and 12" furnished with lifting eyebolt

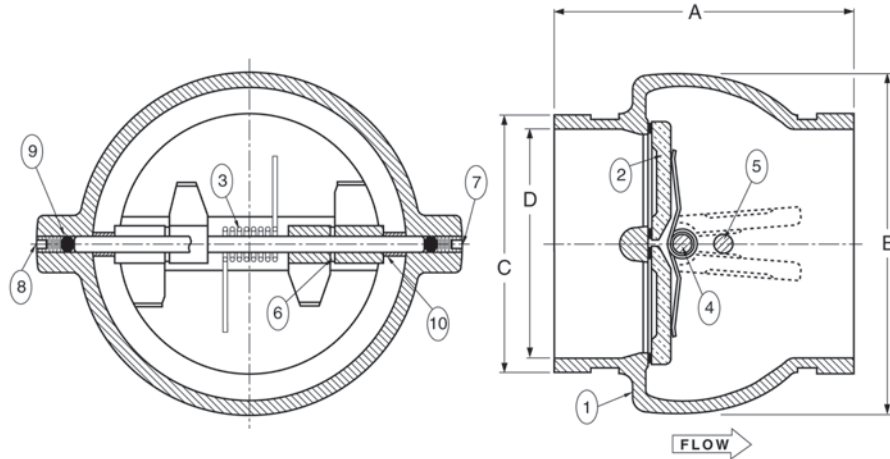

## DIMENSIONS—WEIGHTS—QUANTITIES

Size	Dimensions								KG-900-W-LF	
	A		B		C		D		Lbs.	Kg.
In. mm.	In. mm.	In. mm.	In. mm.	In. mm.	In. mm.	In. mm.	In. mm.			
2½ 65	4.91 125	4.88 124	2.88 73	2.41 61	4.50 114	2.94 75	7.30 165	2.04	0.92	
3 80	5.31 135	5.38 137	3.50 89	2.94 75	7.30 181	2.94 75	7.30 165	2.30	1.04	
4 100	5.38 137	6.00 152	4.50 114	3.91 99	8.60 215	2.94 75	7.30 165	2.60	1.18	
5 125	5.72 145	7.06 179	5.56 141	4.89 124	13.00 329	2.94 75	7.30 165	3.00	1.36	
6 150	6.00 152	8.13 206	6.63 168	5.92 150	18.00 457	2.94 75	7.30 165	3.40	1.54	
8 200	6.72 171	10.03 255	8.63 219	7.91 201	30.00 762	2.94 75	7.30 165	4.00	1.81	
10 250	7.78 198	12.38 314	10.75 273	10.00 254	56.00 1417	2.94 75	7.30 165	4.80	2.18	
12 300	8.19 208	14.38 365	12.75 324	11.94 303	81.80 2077	2.94 75	7.30 165	5.60	2.54	

Groove dimensions conform to ANSI/AWWA specification C606 Table 4 (Cut Groove Dimensions)

\*Lead Free refers to the wetted surface of pipe, fittings and fixtures in potable water systems that have a weighted average lead content ≤ 0.25% per the Safe Drinking Water Act (Sec. 1417) amended 1-4-2011 and other equivalent state regulations.

**NOTE:** Twin Disc Check Valves can be installed horizontally or in the vertical position with flow up.

**CAUTION:** For horizontal flow applications, the valve must be installed with disc hinge pin in the vertical position to insure proper operation.

**WARNING:**

1. These are not to be used as steam valves
2. Valves are not to be used near a reciprocating air compressor
3. Install 5 pipe diameters minimum downstream from pump discharge or elbows to avoid flow turbulence. Flow straighteners may be required in extreme cases.

**NOTE:** On pump discharge, the preferred check valves are in-line spring loaded.

**WARNING:** This product can expose you to chemicals including lead, which is known to the State of California to cause cancer and birth defects or other reproductive harm. For more information go to [www.P65Warnings.ca.gov](http://www.P65Warnings.ca.gov).

Visit our website for the most current information.

LEAD-FREE: Weighted average lead content <0.25%

# 350 PSI CWP Iron Body Grooved Silent Check Valve

Fire Protection • Twin Disc • Grooved Style • Bronze Disc • Nitrile • Spring Actuated

**350 PSI/24 Bar Non-Shock Cold Working Pressure**  
**Maximum Temperature to 180°F/82°C @ 220 PSI/15 Bar**

CERTIFIED LEAD-FREE\* BY WQA TO NSF/ANSI 372  
CONFORMS TO ANSI/AWWA C606 FOR STEEL IPS PIPE  
• UL/ULC LISTED



**C USA**  
**COMPONENT LEAD-FREE**

## MATERIAL LIST

PART	SPECIFICATION
1. Body	Ductile Iron ASTM A536 Grade 65-45-12 w/Buna-N (Nitrile) resilient seat molded to body
2. Disc	Bronze ASTM B584 Alloy C83600
3. Torsion Spring	Stainless Steel UNS 31600 ASTM A313
4. Disc Hinge Pin	Stainless Steel UNS 31600 ASTM A276
5. Disc Stop Pin	Stainless Steel UNS 31600 ASTM A276
6. Disc Thrust Bearing	Stainless Steel UNS 31600 ASTM A240
7. Hinge Pin Retainer	Stainless Steel UNS 31600
8. Stop Pin Retainer	Stainless Steel UNS 31600 I
9. Stabilization Sphere	Buna-N
10. Spacer	Stainless Steel UNS 31600 ASTM A276

Size 10" furnished with lifting eyebolt



**KG-900-W-LF 350**  
Grooved

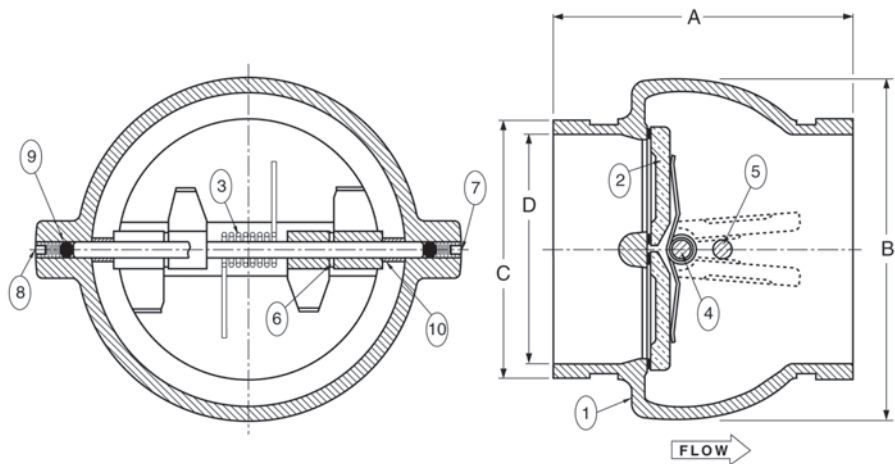

## DIMENSIONS—WEIGHTS—QUANTITIES

Size	Dimensions								KG-900-W-LF 350		
	In.	mm.	In.	mm.	In.	mm.	In.	mm.	Lbs.	Kg.	
2½	65	4.91	125	4.88	124	2.88	73	2.41	61	4.50	2.04
3	80	5.31	135	5.38	137	3.50	89	2.94	75	7.30	3.31
4	100	5.38	137	6.00	152	4.50	114	3.91	99	8.60	3.90
6	150	6.00	152	8.13	206	6.63	168	5.92	150	18.00	8.17
8	200	6.72	171	10.03	255	8.63	219	7.91	201	30.00	13.60
10	250	7.78	198	12.38	314	10.75	273	10.00	254	56.00	25.40

Groove dimensions conform to ANSI/AWWA specification C606 Table 4 (Cut Groove Dimensions)

\*Lead Free refers to the wetted surface of pipe, fittings and fixtures in potable water systems that have a weighted average lead content ≤ 0.25% per the Safe Drinking Water Act (Sec. 1417) amended 1-4-2011 and other equivalent state regulations.

**NOTE:** Twin Disc Check Valves can be installed horizontally or in the vertical position with flow up.

**CAUTION:** For horizontal flow applications, the valve must be installed with disc hinge pin in the vertical position to insure proper operation.

**WARNING:**

1. These are not to be used as steam valves
2. Valves are not to be used near a reciprocating air compressor
3. Install 5 pipe diameters minimum downstream from pump discharge or elbows to avoid flow turbulence. Flow straighteners may be required in extreme cases.

**NOTE:** On pump discharge, the preferred check valves are in-line spring loaded.

**WARNING:** This product can expose you to chemicals including lead, which is known to the State of California to cause cancer and birth defects or other reproductive harm. For more information go to [www.P65Warnings.ca.gov](http://www.P65Warnings.ca.gov).

Visit our website for the most current information.

# Lead-Free 250 PSI WWP Iron Body Check Valves

Fire Protection Valve • UL listed FM Approved  
Double-Door • Wafer Style • Rubber Seat • Spring Actuated

CERTIFIED LEAD-FREE BY WQA TO NSF/ANSI 372  
UL/ULC LISTED • FM APPROVED\*

## MATERIAL LIST

PART	SPECIFICATION
1. Body	Ductile Iron ASTM A536, Grade 65-45-12 - 2½" thru 12" 14" thru 16" Cast Iron ASTM 126, Class B w/ Buna-N (Nitrile) resilient seat molded to body
2. Disc	Bronze ASTM B584 Alloy C87600 (2½" - 12") Aluminum Bronze ASTM B148, C95200 (14"-16")
3. Torsion Spring	Stainless Steel UNS 31600 ASTM A313
4. Hinge Pin	Stainless Steel UNS 31600 ASTM A276
5. Stop Pin	Stainless Steel UNS 31600 ASTM A276
6. Thrust Bearing	Stainless Steel UNS 31600 ASTM A240
7. Hinge Pin Retainer	Stainless Steel UNS 31600
8. Stop Pin Retainer	Stainless Steel UNS 31600
9. Stabilization Sphere	Buna-N
10. Spacer	Stainless Steel UNS S31600 ASTM A276



**KW-900-W-LF**  
Wafer Style  
2½" - 12"  
(excluding 5" & 6")



**C USA**  
**COMPONENT LEAD-FREE**

**UL US LISTED**  
sizes  
2-1/2" - 12" only



- NOTE:** Twin Disc Check Valves can be installed horizontally or in the vertical position with flow up.
- CAUTION:** For horizontal flow applications, the valve must be installed with disc hinge pin in the vertical position to insure proper operation.
- WARNING:**
- These are not to be used as steam valves
  - Valves are not to be used near a reciprocating air compressor
  - Install 5 pipe diameters minimum downstream from pump discharge or elbows to avoid flow turbulence. Flow straighteners may be required in extreme cases.
- NOTE:** On pump discharge, the preferred check valves are in-line spring loaded.

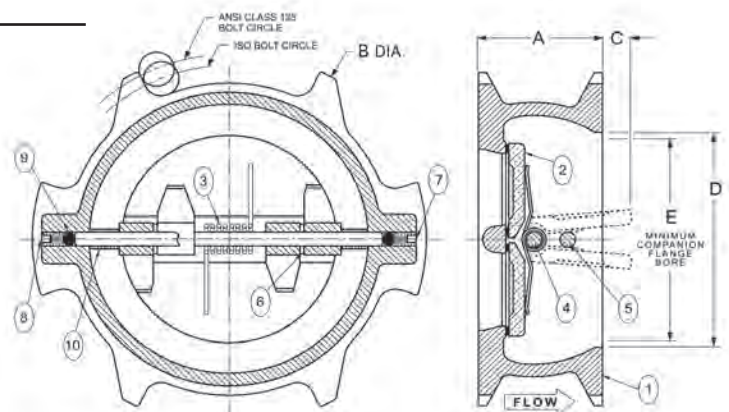

Drawing for sizes 2½" thru 12"

**KW-900-W-LF**  
Wafer

## DIMENSIONS—WEIGHTS—QUANTITIES

Size	Dimensions										Weight		
	A		B		C		D		E		C/V	Lbs.	Kg.
In. mm.	In.	mm.	In.	mm.	In.	mm.	In.	mm.	In.	mm.			
2½ 65	2.38	60	6.00	152	.125	3	3.50	89	1.313	33	108	4.3	1.95
3 80	2.63	67	5.63	143	.188	5	3.875	98	1.688	43	178	6.1	2.77
4 100	2.63	67	7.75	197	.625	16	4.75	121	3.063	78	440	8.8	3.99
5 125	3.25	83	7.56	192	.813	21	5.50	140	3.625	92	560	13.0	5.90
6 150	3.75	95	8.63	219	.813	21	6.25	159	4.250	108	840	18.0	8.16
8 200	5.00	127	12.25	311	1.000	25	8.00	203	5.500	140	1600	37.0	16.78
10 250	5.50	140	14.75	375	2.060	54	10.25	257	8.500	216	2700	65.0	29.48
12 300	7.13	181	17.38	441	1.938	49	12.00	305	9.250	235	4700	94.0	42.64
14 350	7.25	184	17.75	451	3.250	83	14.38	—	12.500	330	5200	200.0	90.75
16 400	7.50	191	20.25	514	4.500	114	16.38	—	15.000	381	7200	285.0	129.28

\*Note: 14" and 16" sizes, 150 PSI WWP, FM approved only – P.O.A.

### Features

- Spring loaded for fast closure, eliminating reverse flow slam and water hammer.
- Easily installed, with gasket, between standard class 125 flanges.
- Only one set of flange studs is needed.
- May be installed in both horizontal and vertical lines with upward flow.

\*Lead Free refers to the wetted surface of pipe, fittings and fixtures in potable water systems that have a weighted average lead content ≤ 0.25% per the Safe Drinking Water Act (Sec. 1417) amended 1-4-2011 and other equivalent state regulations.

Visit our website for the most current information.

**WARNING:** This product can expose you to chemicals including lead, which is known to the State of California to cause cancer and birth defects or other reproductive harm. For more information go to [www.P65Warnings.ca.gov](http://www.P65Warnings.ca.gov).

LEAD-FREE: Weighted average lead content <0.25%



**KW-900-W-LF**

Wafer Style  
Body Style 5", 6", 14" & 16"

# 175 PSI WWP Iron Body Check Valves

Fire Protection Valve • Bolted Bonnet • Horizontal Swing • Renewable Seat and Disc •  
Drilled and Tapped for Ball Drip Outlet



## 175 PSI/12.1 Bar Non-Shock Cold Water

CONFORMS TO MSS SP-71 • UL/ULC LISTED\* •  
FM APPROVED • APPROVED BY THE NEW YORK CITY  
B.S.A. 143-69-SA

### MATERIAL LIST

PART	SPECIFICATION
1. Pipe Plug	Cast Iron or Steel
2. Bonnet	Cast Iron ASTM A126 Class B
3. Bonnet Gasket	Non Asbestos
4. Bonnet Bolt and Nut	Steel ASTM A307
5. Hinge Plug	Cast Bronze B584 Alloy C84400 (not shown)
6. Hinge Pin	Brass ASTM B16
7. Disc Hanger Nut	Cast Bronze B584 Alloy C84400
8. Disc Stud Bolt	Brass ASTM B16 Alloy C36000
9. Disc Cage	Cast Iron ASTM A126 Class B or Malleable Iron ASTM A 47 (not shown)
10. Disc Plate	Cast Bronze B584 Alloy C84400
11. Disc Hanger	Cast Bronze B584 Alloy C84400
12. Disc Nut	Brass ASTM B16 Alloy C36000
13. Seat Ring	Cast Bronze B584 Alloy C84400
14. Disc	Rubber (W)
15. Body	Cast Iron ASTM A126 Class B

**NOTE:** 1.Sizes 2½, 3, 5, & 10 are manufactured, listed and approved by Kennedy Valve and distributed by NIBCO.  
2. Material list applies to sizes 4", 6", 8", 12" only.  
3. All sizes are drilled and tapped ¾" at Boss "C" for ball drip.  
4. NIBCO may substitute Ductile Iron ASTM A395 (60-40-18) for ASTM A126 Class B Cast Iron for the Body, Bonnet, Wedge, or Disc. NIBCO may substitute Ductile Iron ASTM A395 (60-40-18) or ASTM A536 (65-45-12) for all other ASTM A126 Class B Cast Iron components.



**F-908-W**  
Flanged

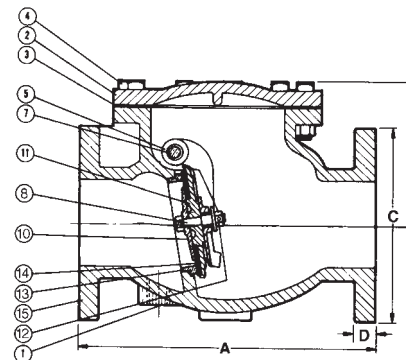

**F-908-W**  
Flg x Flg

### DIMENSIONS—WEIGHTS—QUANTITIES

Size	Dimensions								Weight	
	A		B		C		D		Lbs.	Kg.
In. mm.	In.	mm.	In.	mm.	In.	mm.	In.	mm.		
2½ 65	10.00	254	6.44	164	7.00	178	.69	17	53	24
3 80	10.25	260	6.63	168	7.50	191	.75	19	62	28
4 100	13.00	330	8.00	203	9.00	229	.94	24	103	47
5 125	15.00	381	9.19	233	10.00	254	1.00	25	145	66
6 150	16.25	413	10.31	262	11.00	279	1.00	25	174	79
8 200	19.50	495	11.50	292	13.50	343	1.13	29	290	132
10 250	22.00	559	13.31	338	16.00	406	1.19	30	490	223
12 300	27.50	699	15.56	395	19.00	483	1.25	32	683	310

NIBCO Iron Body check valves may be installed in both horizontal and vertical lines with upward flow.

\* Compliance with the Canadian Requirements per ULC Subject 312 and the Standard for Check Valves, UL 312.

**WARNING:** This product can expose you to chemicals including lead, which is known to the State of California to cause cancer and birth defects or other reproductive harm. For more information go to [www.P65Warnings.ca.gov](http://www.P65Warnings.ca.gov).



Ball Drip

An automatic ball drip is available for NIBCO Underwriter's check valves. The ball drip is installed at boss location "C" on the check valve of the fire department connection. It will close against pressure, but will open when pressure is off allowing water to drain from the fire department connection.

**NOTE:** Must be installed in horizontal position.

¾" Ball Drip # RG 22100  
90° Street Elbow #T046227 PP

Visit our website for the most current information.

## 250 PSI WWP Iron Body Check Valves

Reliable Automatic Sprinkler "G" Series Fire Protection Valve •  
Drilled & Tapped for Ball Drip Outlet • EPDM Seal • Bronze Seat •  
Stainless Steel Disc & Spring Actuated

### 250 PSI/17.2 Bar Non-Shock Cold Water

GROOVES CONFORM TO ANSI AWWA C-606 FOR  
STEEL PIPE • UL/ULC LISTED • FM APPROVED •  
APPROVED BY THE NEW YORK CITY MEA 258-93-E



**G-917-W**  
**(Reliable "G" Series)**

Grooved

### MATERIAL LIST

PART	SPECIFICATION
*1. Valve Body	Cast Iron, ASTM A48 Class 30A
2. Seat	Bronze C83600 or C93200, ASTM B505
3. Clapper	Stainless Steel 304, ASTM A240
**4. Facing Seal	EPDM Rubber
5. Clamping Ring	Stainless Steel 304, ASTM A240
**6. Gasket	EPDM Rubber
7. Spring	Stainless Steel 302, ASTM A313
8. Hinge Pin	Stainless Steel 303, ASTM A582
9. Bolt	Stainless Steel 304, ASTM F593
**10. Locknut	Stainless Steel 303, ASTM F594
11. Plug 1/8" NPT	Steel
12. Plug 1/2" NPT	Steel

\* Not field replaceable.

\*\* Replacement seal kit.

NOTE: All sizes are manufactured, listed and approved by Automatic Sprinkler and distributed by NIBCO.

All sizes drilled and tapped 1/2" for a ball drip.

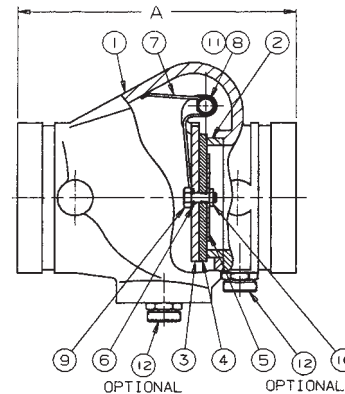

G-917-W

### DIMENSIONS—WEIGHTS—QUANTITIES

Size	Dimension		Weight	
	In.	mm.	Lbs.	Kg.
2 1/2	65	179	9	4
3	80	194	11	5
4	100	214	17	8
6	150	260	38	17

**WARNING:** This product can expose you to chemicals including lead, which is known to the State of California to cause cancer and birth defects or other reproductive harm. For more information go to [www.P65Warnings.ca.gov](http://www.P65Warnings.ca.gov).



Ball Drip

An automatic ball drip is available for NIBCO Underwriter's check valves. The ball drip is installed at boss location "C" on the check valve of the fire department connection. It will close against pressure, but will open when pressure is off allowing water to drain from the fire department connection.

NOTE: Must be installed in horizontal position.

1/2" Ball Drip # RG 22000  
90° Street Elbow #T046212 PP

Visit our website for the most current information.

# Iron Body Grooved Check Valve

Horizontal Swing • Renewable Seat and Disc • AWWA C550 Epoxy Coated

**300 PSI (20.7 BAR) Non-Shock Cold Water to 32°F (0°C) to 180°F (82°C)**  
**Grooved End Connections 2" through 12" Sizes for Fire Protection Water Service**

UL LISTED\* • FM APPROVED\*\*



## MATERIAL LIST

PART	SPECIFICATION
1. Body	Ductile Iron ASTM A536 65-45-12
2. Spring <sup>1</sup>	Stainless Steel S30400
3. Hanger Pin	Stainless Steel S42000
4. Hanger Arm	Ductile Iron ASTM A536 65-45-12
5. Seat	Bronze ASTM B62
6. Seat Disc <sup>1</sup>	EPDM
7. Plate	Ductile Iron ASTM A536 65-45-12
8. Washer <sup>1</sup>	Stainless Steel S30400
9. Nut <sup>1</sup>	Stainless Steel S30400
10. Stud <sup>1</sup>	Stainless Steel S30400
11. Plug	Malleable Iron Galvanized
12. Plug	Malleable Iron Galvanized
13. Plug	Malleable Iron Galvanized
14. Eyebolt	Steel Zinc Plated



**G-997**

**Repair Kit Available**

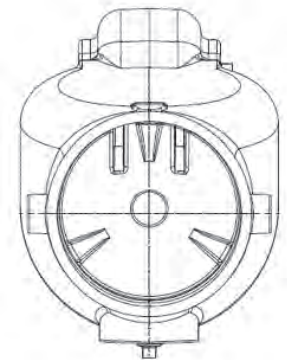
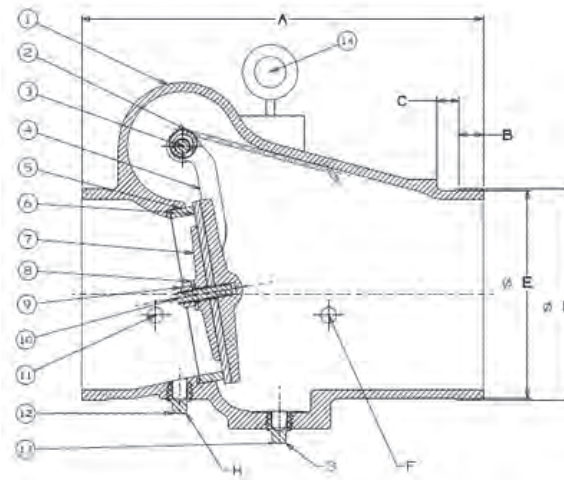

## DIMENSIONS — WEIGHTS

VALVE SIZE	A	B	C	ØD	ØE	F	G	H	WEIGHT	REPAIR KIT
inch mm	inch mm	inch mm	inch mm	inch mm	inch mm	threads	threads	threads	lbs kg	number
2 50	6.75 171	0.63 16	0.31 8	2.38 60	2.25 57	1/2" NPT	1/2" NPT	3/8" NPT	7 3.3	NLN303DS
2½ 65	7.25 184	0.63 16	0.31 8	2.88 73	2.72 69	1/2" NPT	1/2" NPT	3/8" NPT	8 3.6	NLN303ES
3 80	7.75 197	0.63 16	0.31 8	3.50 89	3.34 85	1/2" NPT	1/2" NPT	3/8" NPT	10 4.7	NLN303FS
4 100	8.25 210	0.63 16	0.38 9.5	4.50 114	4.33 110	1/2" NPT	1/2" NPT	1/2" NPT	16 7.3	NLN303HS
5 125	9.85 248	0.63 16	0.38 9.5	5.56 141	5.39 137	1/2" NPT	1/2" NPT	1/2" NPT	20 9.9	NLN303JS
6 150	12.75 324	0.63 16	0.38 9.5	6.63 168	6.45 164	1/2" NPT	1/2" NPT	1/2" NPT	36 16.2	NLN303KS
8 200	14.62 371	0.75 19	0.44 11	8.63 219	8.44 214	1/2" NPT	1/2" NPT	1/2" NPT	60 27.2	NLN303LS
10 250	18.00 457	0.75 19	0.50 12.5	10.75 273	10.56 268	1/2" NPT	1/2" NPT	1/2" NPT	114 25.0	NLN303MS
12 300	21.00 535	0.75 19	0.50 12.5	12.75 324	12.53 318	1/2" NPT	1/2" NPT	1/2" NPT	166 75.7	NLN303NS

Visit our website for the most current information.

# Hi Rise Valves

## Illustrated Index

Ductile Iron Body Gate Valve  
Outside screw and yoke  
Bronze Trim, Solid Wedge  
285 PSI WWP



**F-637-31**  
Sizes 2" thru 12"  
Class 150 Flanged-Raised Face  
**Page 35**

Iron Body Gate Valve  
Outside screw and yoke  
Bronze Trim, Solid Wedge  
500 PSI WWP



**F-667-0**  
Sizes 2" thru 12"  
Class 250 Flanged Ends  
**Page 36**

UL - FM Approved  
Iron Body Gate Valve  
Outside screw and yoke  
Bronze Trim, Solid Wedge  
350 PSI WWP UL/300 PSI WWP FM



**F-697-0**  
Sizes 2 1/2" thru 10"  
Class 250 Flanged Ends  
**Page 37**

Ductile Iron Body Swing Check Valve  
Bronze Trim  
285 PSI WWP



**F-938-31**  
Sizes 2" thru 12"  
Class 150 Flanged-Raised Face  
**Page 38**

Iron Body Swing Check Valve  
Bronze Trim  
500 PSI WWP



**F-968-B**  
Sizes 2 1/2" thru 6"  
Class 250 Flanged Ends  
**Page 39**

Visit our website for the most current information.

# 285 PSI WWP Ductile Iron Body Gate Valves

Fire Protection Valve • Raised Face Flanges Class 150 • Bolted Bonnet •  
Outside Screw and Yoke • Solid Wedge • B584 Bronze Trim

**285 PSI/19.7 Bar Non-Shock Cold Working Pressure**  
**to -20° F to 100° F / -29° C to 38° C**

TESTING SPECIFICATION TO MSS SP-128

## MATERIAL LIST

PART	SPECIFICATION
1. Stem	Copper Alloy, ASTM B371 C69430
2. Nut, Handwheel	Cast Copper Alloy, ASTM B584 C84400
3. Nameplate, I.D.	Aluminum
4. Handwheel, Blue	Cast Iron, ASTM A126-B
5. Bushing, Yoke	Cast Copper Alloy, ASTM B584 C84400
6. Screw, Hex - Bonnet Cap	Steel, ASTM A307 / SAE J429
7. Cap, Bonnet	Ductile Iron ASTM A536
8. Grease Fitting (Not Shown)	Steel
9. Nut, Square - Bonnet Cap	Steel, ASTM A563
10. Bonnet	Ductile Iron ASTM A395
11. Nut, Heavy Hex - Gld Follow	Steel, ASTM A563
12. Gland Follower	Ductile Iron ASTM A536
13. Pack Gland	Powdered Metal ASTM B783
14. Pack Ring	Aramid Fiber / Graphite
15. Bolt, Sq Head - Gld Follow	Steel, ASTM A307 / SAE J429
16. Screw, Hex - Body	Steel, ASTM A193 B7 / SAE J429 Gr 8
17. Gasket, Body	Synthetic Fiber / Nitrile
18. Nut, Hex - Body	Steel, ASTM A194 2H / SAEJ995 Gr 8
19. Collar, Stem	Copper Alloy, ASTM B371 C69400
20. Pin, Wedge	Copper Alloy, ASTM B140 C31600
21. Ring, Seat - Wedge	Cast Copper Alloy, ASTM B584 C84400
22. Wedge	Ductile Iron ASTM A395
23. Ring, Seat - Body	Cast Copper Alloy, ASTM B584 C84400
24. Body	Ductile Iron ASTM A395

<sup>1</sup> Sizes thru 8", Yoke and Bonnet are integral.  
<sup>10"</sup> and <sup>12"</sup> sizes separate Yoke is bolted to Bonnet.

<sup>2</sup> Sizes 2" thru 6" have Cast Copper Alloy Wedges.  
Sizes 8" thru 12" made with Ductile Iron Wedge with Cast Copper Alloy Face Rings.

<sup>3</sup> Lugs may be removed per customer's request - POA.

## DIMENSIONS—WEIGHTS—QUANTITIES

Size	Dimensions										F-637-31 Weight		
	A		B		C		D		E		Lbs.	Kg.	
In.	mm.	In.	mm.	In.	mm.	In.	mm.	In.	mm.	In.	mm.		
2	50	7.00	178	16.26	413	8.00	203	6.00	152	0.62	16	41	19
2½	65	7.50	191	17.26	438	8.00	203	7.00	178	0.69	18	55	25
3	80	8.00	203	19.44	494	8.00	203	4.50	114	0.75	19	67	30
4	100	9.00	229	23.54	598	10.25	260	9.00	229	0.94	24	107	49
5	125	10.00	254	27.01	686	10.25	260	10.00	254	0.94	24	145	66
6	150	10.50	267	30.73	781	12.00	305	11.00	279	1.00	25	178	81
8	200	11.50	292	40.29	1023	14.00	356	13.50	343	1.12	28	309	140
10	250	13.00	330	48.45	1231	16.25	413	16.00	406	1.19	30	481	219
12	300	14.00	356	56.26	1429	18.00	457	19.00	483	1.25	32	706	321

**FREEZING WEATHER PRECAUTION:** Subsequent to testing a piping system, valves should be left in an open position to allow complete drainage.



**F-637-31**  
Flanged-Raised Face

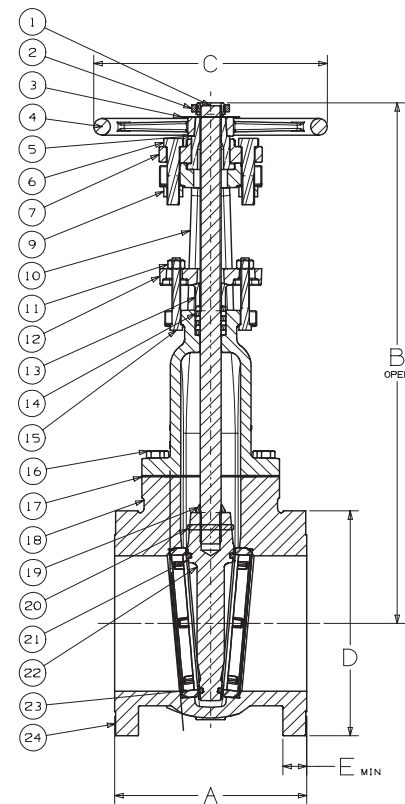

**F-637-31**  
Flg x Flg

**WARNING:** This product can expose you to chemicals including lead, which is known to the State of California to cause cancer and birth defects or other reproductive harm. For more information go to [www.P65Warnings.ca.gov](http://www.P65Warnings.ca.gov).

Visit our website for the most current information.

# 500 PSI WWP Iron Body Gate Valves

Fire Protection Valve • Bolted Bonnet • Outside Screw and Yoke • Solid Wedge • Bronze Mounted • Class 250 Flanges

**500 PSI/34.5 Bar Non-Shock Cold Working Pressure**  
**-20° F to 150° F/-29° C to 66° C**

CONFORMS TO MSS SP-70 • APPROVED BY THE  
NEW YORK CITY B.S.A. 143-69-SA AT 350 PSI  
NON-SHOCK COLD WATER

## MATERIAL LIST

PART	SPECIFICATION
1. Stem	Copper Alloy, ASTM B16 C36000
2. Nut, Handwheel	Cast Copper Alloy, ASTM B584 C84400
3. Nameplate, I.D.	Aluminum
4. Handwheel, Blue	Cast Iron, ASTM A126-B
5. Bushing, Yoke	Cast Copper Alloy, ASTM B584 C84400
6. Screw, Hex - Bonnet Cap	Steel, ASTM A307 / SAE J429
7. Cap, Bonnet	Ductile Iron ASTM A536
8. Nut, Square - Bonnet Cap	Steel, ASTM A563
9. Bonnet	Cast Iron, ASTM A126-B
10. Nut, Heavy Hex - Gld Follow	Steel, ASTM A563
11. Gland Follower	Ductile Iron ASTM A536
12. Pack Gland	Powdered Metal ASTM B783
13. Pack Ring	Aramid Fibers / Graphite
14. Bolt, Sq Head - Gld Follow	Steel, ASTM A307 / SAE J429
15. Screw, Hex - Body	Steel, ASTM A307 / SAE J429
16. Gasket, Body	Reinforced Flexible Graphite
17. Nut, Hex - Body	Steel, ASTM A563
18. Collar, Stem	Copper Alloy, ASTM B16 C36000
19. Nut, Wedge	Cast Copper Alloy, ASTM B584 C84400
20. Ring, Seat - Wedge	Cast Copper Alloy, ASTM B584 C84400
21. Pin, Wedge	Copper Alloy, ASTM B140 C31600
22. Wedge	Cast Iron, ASTM A126-B
23. Ring, Seat - Body	Cast Copper Alloy, ASTM B584 C84400
24. Body	Cast Iron, ASTM A126-B

- <sup>1</sup> Sizes thru 6", Yoke and Bonnet are integral. 8" and 12" sizes separate Yoke is bolted to Bonnet.  
<sup>2</sup> Sizes 2" thru 3" have Cast Copper Alloy Wedges. Sizes 4" thru 12" made with Cast Iron Wedge with Cast Copper Alloy Face Rings.  
<sup>3</sup> Cast Copper Wedge Nuts used on Sizes 5" thru 12".  
<sup>4</sup> 2" thru 8" have Aramid Fibers/Graphite packings. 10" & 12" have Wire reinforced carbon yarn with resilient core/Graphite & Zinc finish.

**NOTE:** NIBCO may substitute Ductile Iron ASTM A395 (60-40-18) for ASTM A126 Class B Cast Iron for the Body, Bonnet, Wedge, or Disc. NIBCO may substitute Ductile Iron ASTM A395 (60-40-18) or ASTM A536 (65-45-12) for all other ASTM A126 Class B Cast Iron components.

## DIMENSIONS—WEIGHTS—QUANTITIES

Size	Dimensions										F-667-0 Weight		
	A		B		C		D		E		Lbs.	Kg.	
In. mm.	In.	mm.	In.	mm.	In.	mm.	In.	mm.	In.	mm.			
2	50	8.50	216	16.06	408	8.00	203	6.50	165	0.87	22	56	25
2½	65	9.50	241	18.31	465	8.00	203	7.50	191	1.00	25	74	34
3	80	11.12	282	21.46	545	10.25	260	8.25	210	1.12	28	122	55
4	100	12.00	305	23.53	598	10.25	260	10.00	254	1.25	32	193	88
5	125	15.00	381	29.74	755	14.00	356	11.00	279	1.37	35	297	135
6	150	15.87	403	33.11	841	16.25	413	12.50	318	1.44	37	411	187
8	200	16.50	419	45.84	1164	16.25	413	15.00	381	1.62	41	637	290
10	250	18.00	457	54.43	1383	20.00	508	17.50	445	1.87	47	897	408
12	300	19.75	502	57.96	1472	20.00	508	20.50	521	2.00	51	1172	533

Visit our website for the most current information.



**F-667-0**  
Flanged

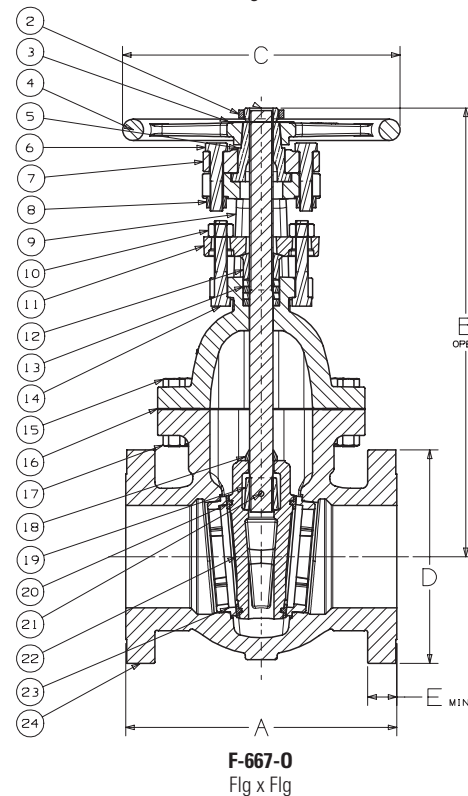

**WARNING:** This product can expose you to chemicals including lead, which is known to the State of California to cause cancer and birth defects or other reproductive harm. For more information go to [www.P65Warnings.ca.gov](http://www.P65Warnings.ca.gov).

**FREEZING WEATHER PRECAUTION:** Subsequent to testing a piping system, valves should be left in an open position to allow complete drainage.

## 300/350 PSI WWP Iron Body Gate Valves

Fire Protection Valve • Bolted Bonnet • Outside Screw and Yoke • Solid Wedge • Class 250 Flanges

### 300/350 PSI/20.7/24 Bar Non-Shock Cold Water



CONFORMS TO MSS SP-70 • UL LISTED 350 PSI •

FM APPROVED 300 PSI • APPROVED BY NEW YORK CITY

M.E.A. 420-92-E VOL. 2 AT 350 PSI NON-SHOCK COLD WATER

### MATERIAL LIST

PART	SPECIFICATION
1. Stem	Copper Alloy, ASTM B16 C36000
2. Nut, Handwheel	Cast Copper Alloy, ASTM B584 C84400
3. Handwheel, Orange	Cast Iron, ASTM A126-B
4. Bushing, Yoke	Cast Copper Alloy, ASTM B584 C84400
5. Screw, Hex - Bonnet Cap	Steel, ASTM A307 / SAE J429
6. Cap, Bonnet	Ductile Iron ASTM A536
7. Nut, Square - Bonnet Cap	Steel, ASTM A563
8. Bonnet <sup>1</sup>	Cast Iron, ASTM A126-B
9. Nut, Heavy Hex - Gld Follow	Stainless Steel, ASTM A240
10. Gland Follower	Ductile Iron ASTM A536
11. Pack Gland	Powdered Metal ASTM B783
12. Pack Ring <sup>4</sup>	Aramid Fibers / Graphite
13. Bolt, Sq Head - Gld Follow	Steel, ASTM A307 / SAE J429
14. Screw, Hex - Body	Steel, ASTM A307 / SAE J429
15. Gasket, Body	Reinforced Flexible Graphite
16. Nut, Hex - Body	Steel, ASTM A563
17. Collar, Stem	Copper Alloy, ASTM B16 C36000
18. Nut, Wedge <sup>3</sup>	Cast Copper Alloy, ASTM B584 C84400
19. Pin, Wedge	Copper Alloy, ASTM B140 C31600
20. Wedge <sup>2</sup>	Cast Iron, ASTM A126-B
21. Ring, Seat - Wedge	Cast Copper Alloy, ASTM B584 C84400
22. Ring, Seat - Body	Cast Copper Alloy, ASTM B584 C84400
23. Body	Cast Iron, ASTM A126-B

<sup>1</sup> Sizes thru 6", Yoke and Bonnet are intergral.

8" and 10" sizes separate Yoke is bolted to Bonnet.

<sup>2</sup> Sizes 2 1/2" and 3" have Cast Copper Alloy Wedges.

Sizes 4" thru 10" made with Cast Iron Wedge with Cast Copper Alloy Face Rings.

<sup>3</sup> Cast Copper Wedge Nuts used on Sizes 5" thru 10".

<sup>4</sup> 2 1/2" thru 8" have Aramid Fiber/Graphite packings. 10" has wire reinforced carbon yarn with resilient core/ Graphite & Zinc finish.

**NOTE:** Supervisory Switch Use Requires Modification to Stem.

**NOTE:** NIBCO may substitute Ductile Iron ASTM A395 (60-40-18) for ASTM A126 Class B Cast Iron for the Body, Bonnet, Wedge, or Disc. NIBCO may substitute Ductile Iron ASTM A395 (60-40-18) or ASTM A536 (65-45-12) for all other ASTM A126 Class B Cast Iron components.



**F-697-0**  
Flanged

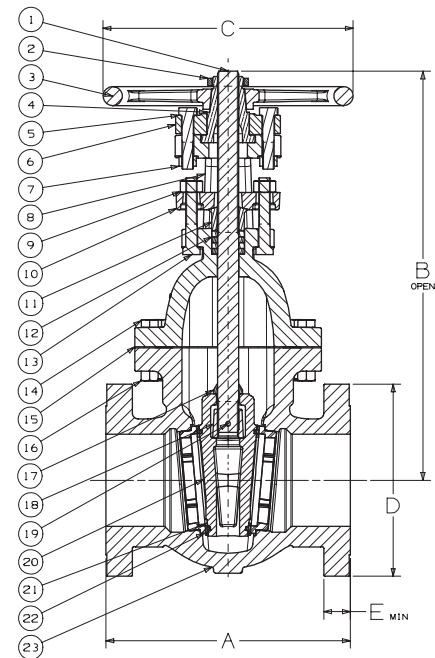

**F-697-0**  
Flg x Flg

### DIMENSIONS—WEIGHTS—QUANTITIES

Size	Dimensions										Weight		
	A		B		C		D		E		Lbs.	Kg.	
In. mm.	In.	mm.	In.	mm.	In.	mm.	In.	mm.	In.	mm.			
2 1/2	65	9.50	241	18.17	462	8.00	203	7.50	191	1.00	25	74	34
3	80	11.12	282	21.46	545	10.25	260	8.25	210	1.12	28	122	55
4	100	12.00	305	23.53	598	10.25	260	10.00	254	1.25	32	193	88
6	150	15.87	403	33.62	854	16.25	413	12.50	318	1.44	37	411	187
8	200	16.50	419	45.84	1164	16.25	413	15.00	381	1.62	41	637	290
10	250	18.00	457	54.44	1383	20.00	508	17.50	445	1.87	47	897	408

**FREEZING WEATHER PRECAUTION:** Subsequent to testing a piping system, gate valves should be left in an open position to allow complete drainage.

**WARNING:** This product can expose you to chemicals including lead, which is known to the State of California to cause cancer and birth defects or other reproductive harm. For more information go to [www.P65Warnings.ca.gov](http://www.P65Warnings.ca.gov).

Visit our website for the most current information.

# 285 PSI WWP Ductile Iron Body Swing Check Valves

Fire Protection Valve • Class 150 • Raised Face Flanges • Bolted Bonnet • B584 Bronze Trim

**285 PSI/19.7 Bar Non-Shock Cold Working Pressure**  
-20° F to 100° F/-29° C to 38° C

TESTING SPECIFICATION TO MSS SP-136

## MATERIAL LIST

PART	SPECIFICATION
1. Bolt	Steel ASTM A193 B7 /SAE J429 Gr8
2. Identification Plate	Aluminum
3. Bonnet	Ductile Iron ASTM A395
4. Body Gasket	Synthetic Fibres
5. Nut	Steel ASTM A194 2H/SAE J995 Gr8
6. Side Plug	Bronze ASTM B584
7. Hanger Pin	Bronze ASTM B371
8. Hanger	Bronze ASTM B584 or Ductile Iron ASTM A536
*9. Disc	Bronze ASTM B584
10. Seat Ring	Bronze ASTM B584
11. Disc Nut	Bronze ASTM B371
12. Body	Ductile Iron ASTM A395



**F-938-31**  
Flanged-Raised Face

## DIMENSIONS—WEIGHTS—QUANTITIES

Size	Dimensions								F-938-31 Weight	
	A		B		D		E		Lbs.	Kg.
In. mm.	In.	mm.	In.	mm.	In.	mm.	In.	mm.		
2 50	8.00	203	3.94	100	6.00	152	.63	16	24	11
2½ 65	8.50	216	4.50	114	7.00	178	.69	17	35	16
3 80	9.50	241	5.13	130	7.50	191	.75	19	47	21
4 100	11.50	292	6.13	156	9.00	229	.94	24	81	37
5 125	13.00	330	6.81	173	10.00	254	.94	24	100	45
6 150	14.00	356	8.00	203	11.00	279	1.00	25	146	66
8 200	19.50	495	9.44	240	13.50	343	1.13	29	255	116
10 250	24.50	622	12.06	306	16.00	406	1.19	30	426	193
12 300	27.50	699	16.13	410	19.00	483	1.25	32	660	299

Lever and Weight/Spring Options available.

\*2"-4" have bronze disc; 5"-12" have ductile iron disc with bronze seat ring

NIBCO Check Valves may be installed in both horizontal and vertical lines with upward flow or in any intermediate position.

Warning: Do not use for Reciprocating Air Compressor Service.

**⚠ WARNING:** This product can expose you to chemicals including lead, which is known to the State of California to cause cancer and birth defects or other reproductive harm. For more information go to [www.P65Warnings.ca.gov](http://www.P65Warnings.ca.gov).

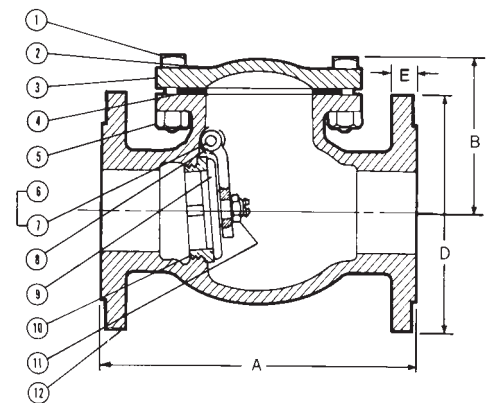

**F-938-31**  
Flg x Flg

Visit our website for the most current information.

# 500 PSI WWP Iron Body Check Valves

Fire Protection Valve • Bolted Bonnet • Horizontal Swing • \*Renewable Bronze Seat and Disc • Class 250 Flanges

**500 PSI/34.5 Bar Non-Shock Cold Working Pressure**  
**-20° F to 150° F/-29° C to 66° C**

CONFORMS TO MSS SP-71 TYPE 1 • APPROVED BY  
NEW YORK CITY B.S.A. 143-69-SA AT 350 PSI  
NON-SHOCK COLD WATER



**F-968-B**  
Flanged

## MATERIAL LIST

PART	SPECIFICATION
1. Body Bolt	Steel ASTM A307
2. Identification Plate	Aluminum
3. Bonnet	Cast Iron ASTM A126 Class B
4. Body Gasket	Reinforced Graphite
5. Body Nut	Steel ASTM A307
6. Side Plug	Brass ASTM B16 Alloy C36000
7. Hanger Pin	Brass ASTM B16 Alloy C36000
8. Hanger	Cast Bronze ASTM B584 Alloy C84400
9. Disc Nut	Cast Bronze ASTM B584 Alloy C84400
10. Disc	Cast Bronze ASTM B584 Alloy C84400
11. Seat Ring	Cast Bronze ASTM B584 Alloy C84400
12. Body	Cast Iron ASTM A126 Class B

**NOTE:** NIBCO may substitute Ductile Iron ASTM A395 (60-40-18) for ASTM A126 Class B Cast Iron for the Body, Bonnet, Wedge, or Disc. NIBCO may substitute Ductile Iron ASTM A395 (60-40-18) or ASTM A536 (65-45-12) for all other ASTM A126 Class B Cast Iron components.

## DIMENSIONS—WEIGHTS—QUANTITIES

Size	Dimensions										F-968-B Weight	
	A		B		D		E		Lbs.	Kg.		
In.	mm.	In.	mm.	In.	mm.	In.	mm.	In.	mm.			
2½	65	11.50	292	5.83	149	7.50	191	1.00	25	62	28	
3	80	12.50	318	6.31	160	8.25	210	1.13	29	77	35	
4	100	14.00	356	7.56	192	10.00	254	1.25	32	129	58	
6	150	17.50	445	8.50	216	12.50	318	1.44	37	225	102	

\* Proper machining facilities required.

NIBCO Iron Body Check Valves may be installed in both horizontal and vertical lines with upward flow or in any intermediate position.

**WARNING:** Do not use for Reciprocating Air Compressor Service.

**WARNING:** This product can expose you to chemicals including lead, which is known to the State of California to cause cancer and birth defects or other reproductive harm. For more information go to [www.P65Warnings.ca.gov](http://www.P65Warnings.ca.gov).

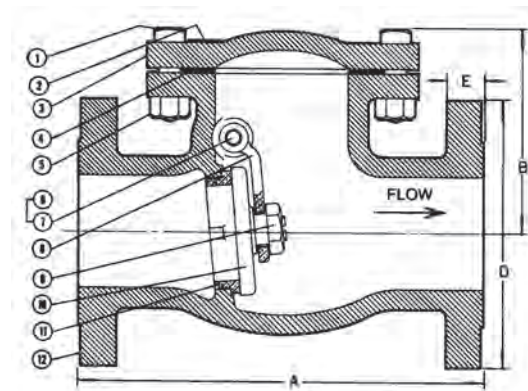







**F-968-B**  
Fig x Flg

Visit our website for the most current information.

# Iron UL/FM Butterfly Valves

## Illustrated Index

<p>UL Listed • FM Approved Ductile Iron Butterfly Valve • Gear Operator with Flag 250 PSI WWP</p>  <p><b>WD-3510-4/8</b> Wafer Style Body Sizes 2" thru 12" <b>Page 41</b></p>	<p>UL Listed • FM Approved Ductile Iron Butterfly Valve • Gear Operator with Flag 250 PSI WWP</p>  <p><b>LD-3510-4/8</b> Lug Style Body Sizes 2" thru 12" <b>Page 41</b></p>	<p>UL Listed • FM Approved Designed for normally closed position monitoring Ductile Iron Butterfly Valve • Gear Operator with Flag 250 PSI WWP</p>  <p><b>WD-3510-C-8</b> Wafer Style Body Sizes 2½" thru 8" <b>Page 42</b></p>
<p>UL Listed • FM Approved Designed for normally closed position monitoring Ductile Iron Butterfly Valve • Gear Operator with Flag</p>  <p><b>LD-3510-C-8</b> Lug Style Body Sizes 2½" thru 8" <b>Page 42</b></p>	<p>UL Listed • FM Approved Nylon Coated Ductile Iron Body • Gear Operator with Flag 300 PSI WWP</p>  <p><b>GD-4865-4N (No Switches)</b> <b>GD-4865-8N</b> Grooved Mechanical Style Sizes 2½" thru 10" <b>Page 43</b></p>	<p>UL Listed • FM Approved Designed for normally closed position monitoring Nylon Coated Ductile Iron Body • Gear Operator with Flag 300 PSI WWP</p>  <p><b>GD-4865-C-8N</b> Grooved Mechanical Style Sizes 2½" thru 10" <b>Page 44</b></p>
<p>UL Listed Nylon Coated Ductile Iron Body • Gear Operator with Flag 350 PSI WWP</p>  <p><b>GD-6865-4N (No Switches)</b> <b>GD-6865-8N</b> Grooved Mechanical Style Sizes 2½" thru 10" <b>Page 45</b></p>	<p>UL Listed • FM Approved Designed for normally closed position monitoring Nylon Coated Ductile Iron Body • Gear Operator with Flag 350 PSI WWP</p>  <p><b>GD-6865-C-8N</b> Grooved Mechanical Style Sizes 2½" thru 10" <b>Page 46</b></p>	

Visit our website for the most current information.

## 250 PSI WWP UL/FM Butterfly Valves

Fire Protection Valve • Wafer or Lug Style Body • Molded in Seat • Accepts Internal Supervisory Switches • Mates with C.I. Class 125/Steel Class 150 Flanges



### 250 PSI/17.2 Bar Non-Shock Cold Water

DESIGNED TO COMPLY WITH MSS SP-67 • UL/ULC LISTED • FM APPROVED •  
2" - 12" UL/FM LISTED FOR INDOOR AND OUTDOOR SERVICE • APPROVED BY NEW  
YORK CITY MEA 90-07-E • CALIFORNIA STATE FIRE MARSHAL  
LISTING NO. 7770-1243:104 • U.S. COAST GUARD "Category A"

#### MATERIAL LIST

PART	SPECIFICATION
1. Stem	Stainless Steel ASTM 582 Type 416
2. Collar Bushing	Brass ASTM B124
3. Upper Bushing	Copper Alloy CDA 122
4. Stem Seal	EPDM
5. Body Seal	EPDM
6. Disc	Ductile Iron ASTM 395 (Nickel Plated)
7. Liner	EPDM
8. Lower Bushing	Copper Alloy CDA 122
9. Nameplate	Aluminum
10. Body	Ductile Iron ASTM A536
11. Gear Operator	Cast Iron and Steel
12. Indicator Flag	Cast Iron
13. Handwheel	Cast Iron



**LD-3510-8\*\***  
Lug



**WD-3510-8\*\***  
Wafer  
(4" Shown)

\*\*-8 version has two factory mounted internal supervisory switches.  
-4 version has no switches.

Note: Wafer body will mate with ANSI or ISO flanges. O.D. of wafer body notched to fit ISO bolt circle.  
For dead-end service use lug style (rated 200 PSI for this service).

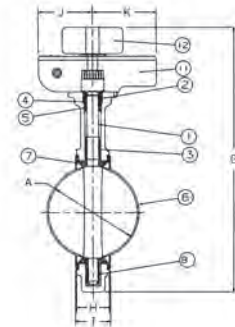
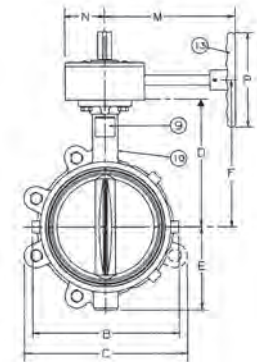

(10" Shown)

#### DIMENSIONS—WEIGHTS—QUANTITIES

Size	Dimensions																				
	A	B	C	D	E	F	G	H	I	J											
2	50	2.53	64	4.88	124	4.62	117	5.38	137	2.88	73	6.89	175	12.75	324	1.68	43	1.81	46	2.91	74
2½	65	2.90	74	5.62	143	5.12	130	5.88	149	3.25	83	7.36	187	13.63	346	1.81	46	1.94	49	2.91	74
3	80	3.17	81	6.12	155	5.50	140	6.12	155	3.38	86	7.60	193	14.00	356	1.81	46	1.94	49	2.91	74
4	100	4.17	106	7.00	178	8.25	210	6.88	175	4.00	102	8.39	213	15.38	391	2.06	52	2.19	56	2.91	74
5	125	5.17	131	8.25	210	9.38	238	7.38	187	4.75	121	8.86	225	16.63	422	2.19	56	2.31	59	2.91	74
6	150	6.17	157	9.25	235	10.25	260	8.00	203	5.25	133	9.49	241	17.75	451	2.19	56	2.31	59	2.91	74
8	200	8.17	208	11.62	295	12.38	314	9.25	235	6.50	165	10.75	273	20.25	514	2.38	60	2.50	64	2.91	74
10	250	10.17	258	14.25	362	15.50	394	10.50	267	8.00	203	12.28	312	23.50	597	2.68	69	2.81	71	3.90	99
12	300	12.17	309	16.75	425	18.25	464	12.00	305	9.25	235	13.78	350	26.25	667	3.00	76	3.12	79	3.90	99

Size	Dimensions					No.	Flange/Stud Data				Weight											
	K	M	N	P	Dia		Wafer	Lug	BC	Lug	Wafer											
2	50	3.54	90	5.82	148	2.13	54	5.9	150	4	⅝	16	4.00	101	1.25	32	4.75	121	23	11	21	10
2½	65	3.54	90	5.82	148	2.13	54	5.9	150	4	⅝	16	4.25	108	1.50	38	5.50	140	25	11	24	11
3	80	3.54	90	5.82	148	2.13	54	5.9	150	4	⅝	16	4.25	108	1.50	38	6.00	152	26	12	24	11
4	100	3.54	90	5.82	148	2.13	54	5.9	150	8	⅝	16	5.00	127	2.00	51	7.50	191	31	14	27	12
5	125	3.54	90	7.64	194	2.13	54	5.9	150	8	¾	20	5.25	133	2.00	51	8.50	216	37	17	31	14
6	150	3.54	90	7.64	194	2.13	54	5.9	150	8	¾	20	5.25	133	2.00	51	9.50	241	40	18	34	15
8	200	3.54	90	7.91	201	2.13	54	9.8	250	8	¾	20	5.75	146	2.25	57	11.75	298	55	25	49	22
10	250	3.98	101	9.49	241	3.03	77	18.0	457	12	⅞	22	6.25	159	2.50	64	14.25	362	95	43	78	35
12	300	3.98	101	9.49	241	3.03	77	18.0	457	12	⅞	22	6.75	171	2.50	64	17.00	432	123	56	103	47

**WARNING:** This product can expose you to chemicals including lead, which is known to the State of California to cause cancer and birth defects or other reproductive harm. For more information go to [www.P65Warnings.ca.gov](http://www.P65Warnings.ca.gov).

Visit our website for the most current information.

# 250 PSI WWP UL/FM Butterfly Valves

Designed for normally closed position monitoring

Fire Protection Valve • Lug or Wafer Style Body • Factory Mounted Monitoring Switches • Mates with C.I. Class 125 and Steel Class 150 Flanges

**250 PSI/17.2 bar non-shock cold water**

THIRD PARTY CERTIFIED BY QAI TO MEET MSS SP-67 STANDARD •  
UL/ULC LISTED\*\* • FM APPROVED\*\* • CERTIFIED LEAD FREE BY TRUESDAIL LABS  
2½" - 8" UL LISTED FOR INDOOR AND OUTDOOR SERVICE  
• CALIFORNIA FIRE MARSHALL

**Warning: these valves are not to be used between the water source and sprinkler head.**



## MATERIAL LIST

PART	SPECIFICATION
1. Stem	Stainless Steel ASTM 582 Type 416
2. Collar Bushing	Brass ASTM B16
3. Upper Bushing	Copper Alloy CDA 122
4. Stem Seal	EPDM
5. Body Seal	EPDM
6. Disc	Ductile Iron ASTM 395 (Nickel Plated)
7. Liner	EPDM
8. Lower Bushing	Copper Alloy CDA 122
9. Nameplate	Aluminum
10. Body	Ductile Iron ASTM A536
11. Gear Operator	Cast Iron and Steel
12. Indicator Flag	Cast Iron
13. Handwheel	Cast Iron

Note: wafer body will mate with ANSI or ISO flanges. O.D. of wafer body notched to fit ISO bolt circle.

For dead-end service use lug style (rated 250 PSI for this service).

Comes with two factory mounted internal supervisory switches. Use switch Figure No. TS-4. See Section VI of the Rubber-Seated Butterfly Valve O&M Manual.

**WARNING:** This product can expose you to chemicals including lead, which is known to the State of California to cause cancer and birth defects or other reproductive harm. For more information go to www.P65Warnings.ca.gov.

## DIMENSIONS—WEIGHTS—QUANTITIES

Size	Dimensions										
	A	B	C	D	E	F	G	H	I	J	
In. mm.	In. mm.	In. mm.	In. mm.	In. mm.	In. mm.	In. mm.	In. mm.	In. mm.	In. mm.	In. mm.	
2½	65 2.90	74 5.62	143 5.12	130 5.88	149 3.25	83 7.36	187 13.63	346 1.81	46 1.94	49 2.91	74
3	80 3.17	81 6.12	155 5.50	140 6.12	155 3.38	86 7.60	193 14.00	356 1.81	46 1.94	49 2.91	74
4	100 4.17	106 7.00	178 8.25	210 6.88	175 4.00	102 8.39	213 15.38	391 2.06	52 2.19	56 2.91	74
6	150 6.17	157 9.25	235 10.25	260 8.00	203 5.25	133 9.49	241 17.75	451 2.19	56 2.31	59 2.91	74
8	200 8.17	208 11.62	295 12.38	314 9.25	235 6.50	165 10.75	273 20.25	514 2.38	60 2.50	64 2.91	74

Size	Dimensions				Flange/Stud Data				Weight		
	K	M	N	P	Dia	Wafer	Lug	BC	Lug	Wafer	
In. mm.	In. mm.	In. mm.	In. mm.	In. mm.	No.	In. mm.	In. mm.	In. mm.	Lbs. Kg.	Lbs. Kg.	
2½	65 3.54	90 5.82	148 2.13	54 5.9	150 4	5/8 16	4.25 108	1.50 38	5.50 140	25 11	24 11
3	80 3.54	90 5.82	148 2.13	54 5.9	150 4	5/8 16	4.25 108	1.50 38	6.00 152	26 12	24 11
4	100 3.54	90 5.82	148 2.13	54 5.9	150 8	5/8 16	5.00 127	2.00 51	7.50 191	31 14	27 12
6	150 3.54	90 7.64	194 2.13	54 5.9	150 8	¾ 20	5.25 133	2.00 51	9.50 241	40 18	34 15
8	200 3.54	90 7.91	201 2.13	54 9.8	250 8	¾ 20	5.75 146	2.25 57	11.75 298	55 25	49 22

\*\*Compliance with standards for butterfly valves for fire protection UL1091 & FM1112

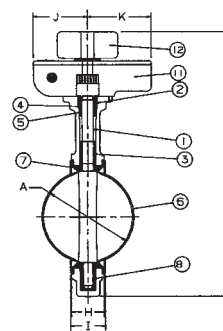
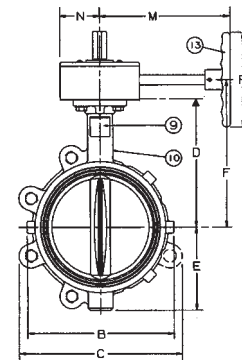

\*Lead Free refers to the wetted surface of pipe, fittings and fixtures in potable water systems that have a weighted average lead content ≤ 0.25% per the Safe Drinking Water Act (Sec. 1417) amended 1-4-2011 and other equivalent state regulations.

Visit our website for the most current information.

# 300 PSI WWP UL/FM Butterfly Valves

Designed for normally open position monitoring

Fire Protection Valve • Grooved Mechanical Style • Nylon Coated Ductile Iron Body •  
Extended Neck • Elastomer Encapsulated Disc • Accepts Internal Supervisory Switches •  
Compatible with IPS Pipe†

## 300 PSI/20.7 Bar Non-Shock Cold Water

UL/ULC LISTED\*\* • UL/FM LISTED FOR INDOOR AND  
OUTDOOR SERVICE • THIRD PARTY CERTIFIED  
TO NSF/ANSI/CAN 61 AND 372 • CALIFORNIA STATE FIRE  
MARSHALL LISTING NO. 7770-1243:104

### MATERIAL LIST

PART	SPECIFICATION
1 Indicator Flag	Painted Steel
2 Stem Adapter	Steel
3 Gear Operator	Cast Iron and Steel
4 Retaining Ring	Carbon Steel
5 Cartridge Seal	Brass ASTM C36000
6 Stem Seals	EPDM
7 Upper Stem	Stainless Steel ASTM A582 Type 416
8 Upper Bushing	Plated Steel with PTFE Lining
9 Body	Ductile Iron ASTM A395 with Polyamide Coating
10 Disc	Ductile Iron ASTM A536 with EPDM Encapsulation
11 Lower Bushing	Steel with PTFE Lining
12 Lower Stem	Stainless Steel ASTM A582 Type 416
13 Handwheel	Cast Iron

Factory mounted with two internal supervisory switches.  
Uses NIBCO model T1446762 PP switch.  
Ground post (-GP) and wall post (-WP) available.  
Normally open monitored only.  
See Section VI of the Rubber-Seated Butterfly Valve O&M Manual.

**WARNING:** This product can expose you to chemicals including lead, which is known to the State of California to cause cancer and birth defects or other reproductive harm. For more information go to www.P65Warnings.ca.gov.



**GD-4865-4N**  
(not shown)  
No Switches

**GD-4865-8N**  
Grooved  
2½", 3", 4", 6", 8", 10"

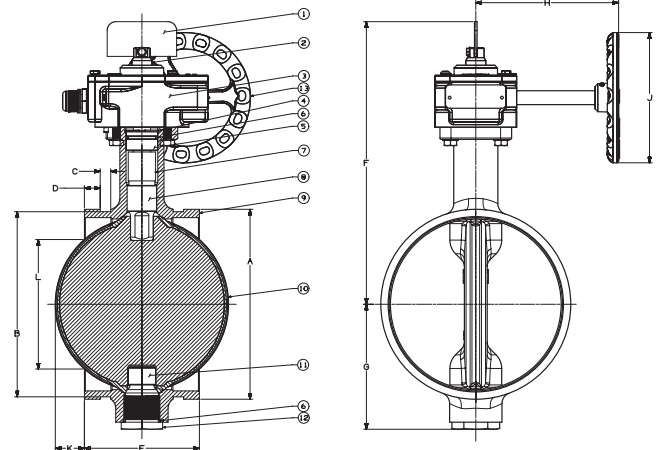

### DIMENSIONS—WEIGHTS

SIZE	Dimensions																Weight								
	A	B	C	D	E	F	G	H	J	K	L	Lbs.	Kg.												
2½"	65	2.88	73	2.72	69	0.31	8	0.63	16	3.81	97	8.95	227	2.20	56	4.92	125	4.25	108	—	—	—	—	9.5	4.3
3 OD	76.1	3.00	76.1	2.85	72	0.31	8	0.63	16	3.81	97	9.16	233	2.47	63	4.92	125	4.25	108	—	—	—	—	11.3	5.2
3	80	3.50	80.0	3.34	85	0.31	8	0.63	16	3.81	97	9.16	233	2.47	63	4.92	125	4.25	108	—	—	—	—	11.6	5.3
4	100	4.50	114.3	4.33	110	0.38	10	0.63	16	4.56	116	10.00	254	3.00	76	4.92	125	4.25	108	—	—	—	—	15.0	6.8
6 OD	165.1	6.50	165.1	6.33	161	0.38	10	0.63	16	5.81	148	11.92	303	4.33	110	6.48	165	6	152	—	—	—	—	31.5	14.3
6	150	6.63	168.3	6.45	164	0.38	10	0.63	16	5.81	148	11.92	303	4.33	110	6.48	165	6	152	—	—	—	—	31.3	14.2
8	200	8.63	219	8.44	214	0.44	11	0.75	19	5.25	133	12.85	326	5.67	114	6.48	165	6	152	1.32	34	5.87	149	43.0	19.5
10	250	10.77	250	10.55	268	0.50	13	0.75	19	6.25	159	15	381	6.77	172	8.74	222	6	152	1.74	44	7.44	189	77.0	35

\*\* Compliance with the Standard for Butterfly Valves for Fire Protection Service, UL 1091, and Indicating Valves, FM Class Number 1112.

† See Grooved Pipe Specification section

Visit our website for the most current information.

# 300 PSI WWP UL/FM Butterfly Valves

Designed for normally closed position monitoring

Fire Protection Valve • Grooved Mechanical Style • Nylon Coated Ductile Iron Body • Extended Neck • Elastomer Encapsulated Disc • Factory Installed Internal Monitoring Switches • Compatible with IPS Pipe†



**300 PSI/20.7 Bar Non-Shock Cold Water 2½" - 10"**

**Warning: These valves are not to be used between the water source and sprinkler head.**

UL/ULC LISTED\*\* • 2½" -10" LISTED FOR INDOOR AND OUTDOOR SERVICE • THIRD PARTY CERTIFIED TO NSF/ANSI/CAN 61 AND 372 • CALIFORNIA STATE FIRE MARSHALL LISTING NO. 7770-1243:0500

## MATERIAL LIST

PART	SPECIFICATION
1 Indicator Flag	Painted Steel
2 Stem Adapter	Steel
3 Gear Operator	Cast Iron and Steel
4 Retaining Ring	Carbon Steel
5 Cartridge Seal	Brass ASTM C36000
6 Stem Seals	EPDM
7 Upper Stem	Stainless Steel ASTM A582 Type 416
8 Upper Bushing	Plated Steel with PTFE Lining
9 Body	Ductile Iron ASTM A395 with Polyamide Coating
10 Disc	Ductile Iron ASTM A536 with EPDM Encapsulation
11 Lower Bushing	Steel with PTFE Lining
12 Lower Stem	Stainless Steel ASTM A582 Type 416
13 Handwheel	Cast Iron

**Note:** Comes with two factory mounted internal supervisory switches. Uses NIBCO model T1447532 PP switch. See Section VI of the Rubber-Seated Butterfly Valve O&M Manual. Ground post or wall post not available. Normally closed monitored.

**WARNING:** This product can expose you to chemicals including lead, which is known to the State of California to cause cancer and birth defects or other reproductive harm. For more information go to [www.P65Warnings.ca.gov](http://www.P65Warnings.ca.gov).



**GD-4865-C-8N**

2½", 3", 4", 6", 8", 10"

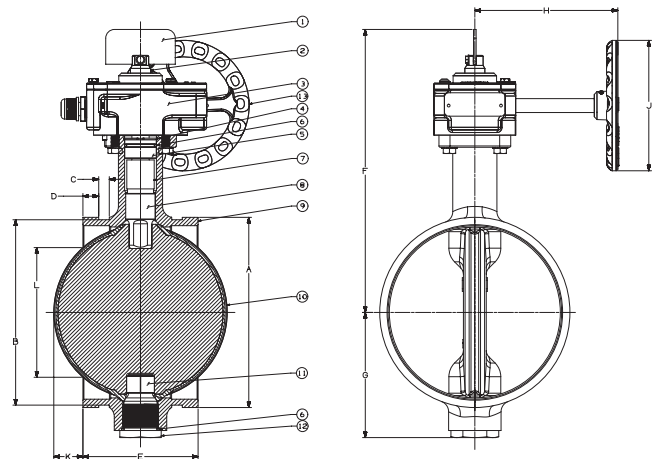

## DIMENSIONS—WEIGHTS

SIZE	Dimensions																				Weight				
	A	B	C	D	E	F	G	H	J	K	L	Lbs.	Kg.												
In. mm.	In. mm.	In. mm.	In. mm.	In. mm.	In. mm.	In. mm.	In. mm.	In. mm.	In. mm.	In. mm.	In. mm.	In. mm.	In. mm.	In. mm.	In. mm.	In. mm.	In. mm.	In. mm.	In. mm.	In. mm.	Lbs.	Kg.			
2½"	65	2.88	73	2.72	69	0.31	8	0.63	16	3.81	97	8.95	227	2.20	56	4.92	125	4.25	108	—	—	—	—	9.5	4.3
3 OD	76.1	3.00	76.1	2.85	72	0.31	8	0.63	16	3.81	97	9.16	233	2.47	63	4.92	125	4.25	108	—	—	—	—	11.3	5.2
3	80	3.50	80.0	3.34	85	0.31	8	0.63	16	3.81	97	9.16	233	2.47	63	4.92	125	4.25	108	—	—	—	—	11.6	5.3
4	100	4.50	114.3	4.33	110	0.38	10	0.63	16	4.56	116	10.00	254	3.00	76	4.92	125	4.25	108	—	—	—	—	15.0	6.8
6 OD	165.1	6.50	165.1	6.33	161	0.38	10	0.63	16	5.81	148	11.92	303	4.33	110	6.48	165	6	152	—	—	—	—	31.5	14.3
6	150	6.63	168.3	6.45	164	0.38	10	0.63	16	5.81	148	11.92	303	4.33	110	6.48	165	6	152	—	—	—	—	31.3	14.2
8	200	8.63	219	8.44	214	0.44	11	0.75	19	5.25	133	12.85	326	5.67	114	6.48	165	6	152	1.32	34	5.87	149	43.0	19.5
10	250	10.77	250	10.55	268	0.50	13	0.75	19	6.25	159	15	381	6.77	172	8.74	222	6	152	1.74	44	7.44	189	77.0	35

\*\* Compliance with the Standard for Butterfly Valves for Fire Protection Service, UL 1091 and Indicating Valves, FM Class Number 1112.

† See Grooved Pipe Specification section

Visit our website for the most current information.

## 350 PSI WWP UL/FM Butterfly Valves

Designed for normally open position monitoring

Fire Protection Valve • Grooved Mechanical Style • Nylon Coated Ductile Iron Body • Extended Neck • Elastomer Encapsulated Disc • Internal Supervisory Switches • Compatible with IPS Pipe†



### 350 PSI/24 Bar Non-Shock Cold Water 2½" - 10"

UL/ULC LISTED\*\* • UL/FM LISTED FOR INDOOR AND OUTDOOR SERVICE • THIRD PARTY CERTIFIED TO NSF/ANSI/CAN 61 AND 372 • CALIFORNIA STATE FIRE MARSHALL LISTING NO. 7770-1243:0500

#### MATERIAL LIST

PART	SPECIFICATION
1 Indicator Flag	Painted Steel
2 Stem Adapter	Steel
3 Gear Operator	Cast Iron and Steel
4 Retaining Ring	Carbon Steel
5 Cartridge Seal	Brass ASTM C36000
6 Stem Seals	EPDM
7 Upper Stem	Stainless Steel ASTM A582 Type 416
8 Upper Bushing	Steel with PTFE Lining
9 Body	Ductile Iron ASTM A395 with Polyamide Coating
10 Disc	Ductile Iron ASTM A536 with EPDM Encapsulation
11 Lower Bushing	Steel with PTFE Lining
12 Lower Stem	Stainless Steel ASTM A582 Type 416
13 Handwheel	Cast Iron

Factory mounted with two internal supervisory switches. Uses NIBCO model T1446762 PP switch. Ground post (-GP) and wall post (-WP) available. Normally open monitored only. Section VI of the Rubber-Seated Butterfly Valve O&M Manual.

**WARNING:** This product can expose you to chemicals including lead, which is known to the State of California to cause cancer and birth defects or other reproductive harm. For more information go to www.P65Warnings.ca.gov.



**GD-6865-4N**  
(not shown)  
No Switches

**GD-6865-8N**  
Grooved  
2½", 3", 4", 6", 8", 10"

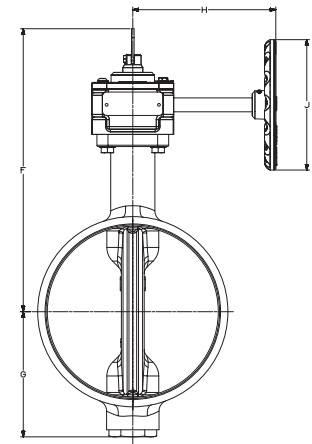
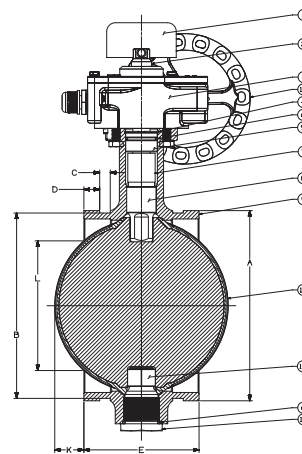

#### DIMENSIONS—WEIGHTS

SIZE	Dimensions												Weight		
	A	B	C	D	E	F	G	H	J	K	L	Lbs.	Kg.		
In. mm.	In. mm.	In. mm.	In. mm.	In. mm.	In. mm.	In. mm.	In. mm.	In. mm.	In. mm.	In. mm.	In. mm.	In. mm.	In. mm.	In. mm.	In. mm.
2½"	65 2.88	73 2.72	69 0.31	8 0.63	16 3.81	97 8.95	227 2.20	56 4.92	125 4.25	108 —	— —	— —	— —	9.5	4.3
3 OD	76.1 3.00	76.1 2.85	72 0.31	8 0.63	16 3.81	97 9.16	233 2.47	63 4.92	125 4.25	108 —	— —	— —	— —	11.3	5.2
3	80 3.50	80.0 3.34	85 0.31	8 0.63	16 3.81	97 9.16	233 2.47	63 4.92	125 4.25	108 —	— —	— —	— —	11.6	5.3
4	100 4.50	114.3 4.33	110 0.38	10 0.63	16 4.56	116 10.00	254 3.00	76 4.92	125 4.25	108 —	— —	— —	— —	15.0	6.8
6 OD	165.1 6.50	165.1 6.33	161 0.38	10 0.63	16 5.81	148 11.92	303 4.33	110 6.48	165 6	152 —	— —	— —	— —	31.5	14.3
6	150 6.63	168.3 6.45	164 0.38	10 0.63	16 5.81	148 11.92	303 4.33	110 6.48	165 6	152 —	— —	— —	— —	31.3	14.2
8	200 8.63	219 8.44	214 0.44	11 0.75	19 5.25	133 12.85	326 5.67	114 6.48	165 6	152 1.32	34 5.87	149 43.0	19.5	43.0	19.5
10	250 10.77	250 10.55	268 0.50	13 0.75	19 6.25	159 15	381 6.77	172 8.74	222 6	152 1.74	44 7.44	189 77.0	35	77.0	35

\*\* Compliance with the Standard for Butterfly Valves for Fire Protection Service, UL 1091, and Indicating Values, FM Class Number 1112.

† See Grooved Pipe Specification section

Visit our website for the most current information.

# 350 PSI WWP UL/FM Butterfly Valves

Designed for normally closed position monitoring

Fire Protection Valve • Grooved Mechanical Style • Nylon Coated Ductile Iron Body • Extended Neck • Elastomer Encapsulated Disc • Factory Installed Internal Monitoring Switches • Compatible with IPS Pipe



**350 PSI/24 Bar Non-Shock Cold Water 2½" - 10"**

**Warning: These valves are not to be used between the water source and sprinkler head.**

UL/ULC LISTED\*\* • 2½" - 10" LISTED FOR INDOOR AND OUTDOOR SERVICE • THIRD PARTY CERTIFIED TO NSF/ANSI/CAN 61 AND 372 • CALIFORNIA STATE FIRE MARSHALL LISTING NO. 7770-1243:0500



**GD-6865-C-8N**

2½", 3", 4", 6", 8", 10"

## MATERIAL LIST

PART	SPECIFICATION
1 Indicator Flag	Painted Steel
2 Stem Adapter	Steel
3 Gear Operator	Cast Iron and Steel
4 Retaining Ring	Carbon Steel
5 Cartridge Seal	Brass ASTM C36000
6 Stem Seals	EPDM
7 Upper Stem	Stainless Steel ASTM A582 Type 416
8 Upper Bushing	Steel with PTFE Lining
9 Body	Ductile Iron ASTM A395 with Polyamide Coating
10 Disc	Ductile Iron ASTM A536 with EPDM Encapsulation
11 Lower Bushing	Steel with PTFE Lining
12 Lower Stem	Stainless Steel ASTM A582 Type 416
13 Handwheel	Cast Iron

**Note:** Comes with two factory mounted internal supervisory switches. Uses NIBCO model T1447532 PP switch. See Section VI of the Rubber-Seated Butterfly Valve O&M Manual.

Ground post or wall post not available. Normally closed monitored.

**WARNING:** This product can expose you to chemicals including lead, which is known to the State of California to cause cancer and birth defects or other reproductive harm. For more information go to [www.P65Warnings.ca.gov](http://www.P65Warnings.ca.gov).

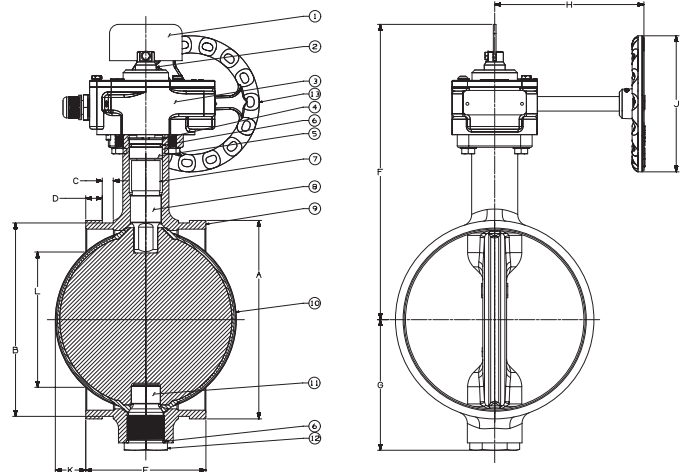

## DIMENSIONS—WEIGHTS

SIZE	Dimensions												Weight												
	A	B	C	D	E	F	G	H	J	K	L	Lbs.	Kg.												
2½"	65	2.88	73	2.72	69	0.31	8	0.63	16	3.81	97	8.95	227	2.20	56	4.92	125	4.25	108	—	—	—	—	9.5	4.3
3 OD	76.1	3.00	76.1	2.85	72	0.31	8	0.63	16	3.81	97	9.16	233	2.47	63	4.92	125	4.25	108	—	—	—	—	11.3	5.2
3	80	3.50	80.0	3.34	85	0.31	8	0.63	16	3.81	97	9.16	233	2.47	63	4.92	125	4.25	108	—	—	—	—	11.6	5.3
4	100	4.50	114.3	4.33	110	0.38	10	0.63	16	4.56	116	10.00	254	3.00	76	4.92	125	4.25	108	—	—	—	—	15.0	6.8
6 OD	165.1	6.50	165.1	6.33	161	0.38	10	0.63	16	5.81	148	11.92	303	4.33	110	6.48	165	6	152	—	—	—	—	31.5	14.3
6	150	6.63	168.3	6.45	164	0.38	10	0.63	16	5.81	148	11.92	303	4.33	110	6.48	165	6	152	—	—	—	—	31.3	14.2
8	200	8.63	219	8.44	214	0.44	11	0.75	19	5.25	133	12.85	326	5.67	114	6.48	165	6	152	1.32	34	5.87	149	43.0	19.5
10	250	10.77	250	10.55	268	0.50	13	0.75	19	6.25	159	15	381	6.77	172	8.74	222	6	152	1.74	44	7.44	189	77.0	35

\*\* Compliance with the Standard for Butterfly Valves for Fire Protection Service, UL 1091, and Indicating Valves, FM Class Number 1112.

† See Grooved Pipe Specification section

Visit our website for the most current information.

# NIBCO Fire Protection Butterfly Valves

ITEM	VALVE SIZE	VALVE ASSEMBLY FIGURE NUMBER	BUSHING REFERENCE NUMBER	BUSHING ASSEMBLY PART NUMBER	DRIVE KEY PART NUMBER	DRIVE KEY SIZE	DRIVE KEY MATERIAL
1	2"	WD/LD 3510	01	T117725 PP	T117850 PP	1/8" SQ. X .38 LG.	BRASS
2	2 1/2" & 3"	WD/LD 3510	02	T117726 PP	T117851 PP	1/8" SQ. X .68 LG.	BRASS
3	2 1/2" & 3"	GD-4765/6765	02	T117726 PP	T117850 PP	1/8" SQ. X .38 LG.	BRASS
4	2 1/2" & 3"	GD-4865/6865	—	T118778 PP	T117852 PP	1/8" SQ. X .44 LG.	STEEL
5	4"	WD/LD 3510	03	T117727 PP	T117852 PP	1/8" SQ. X .44 LG.	STEEL
6	4"	GD-4865/6865	—	T1427913 PP	T117852 PP	1/8" SQ. X .44 LG.	STEEL
7	4" & 5"	GD-4765/6765	04	T117728 PP	T117853 PP	1/8" SQ. X .29 LG.	STEEL
8	5" & 6"	WD/LD 3510	04	T117728 PP	T117854 PP	1/8" SQ. X .41 LG.	STEEL
9	6" & 8"	GD-4765/6765	05	T117729 PP	T117856 PP	1/8" SQ. X .91 LG.	STEEL
10	6" & 8"	GD-4865/6865	—	T118780 PP	T117856 PP	1/8" SQ. X .91 LG.	STEEL
11	8"	WD/LD 3510	05	T117729 PP	T117856 PP	1/8" SQ. X .91 LG.	STEEL
12	10"	GD-4765/6765	06	T117730 PP	T117858 PP	3/16" SQ. X 1.00 LG	STEEL
13	10"	GD-4865/6865	—	T118781 PP	T117858 PP	3/16" SQ. X 1.00 LG	STEEL
14	10" & 12"	WD/LD 3510	07	T117731 PP	T117858 PP	3/16" SQ. X 1.00 LG	STEEL

Visit our website for the most current information.



# Butterfly Valves Indicator Post Assemblies

Available as Wall Post (WP\*) or Underground (GP\*\*)

Available with Internal Supervisory Switch 2" - 8" (UL Listed Indoor/Outdoor) - (8N Version)

Available with Grooved, Wafer or Lug Style Valves (UL Listed, Not FM Approved)

See Tech Bulletin on nibco.com for proper post sizing

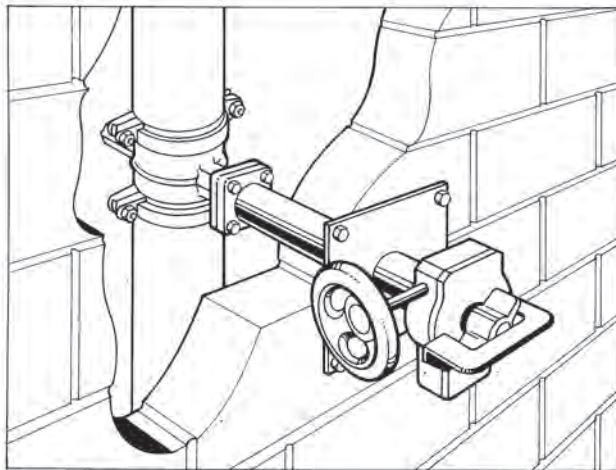

## GD-4865-8WP

Grooved Butterfly  
Wall Post Assembly  
(22" standard length)

## Mounting Hole Size

2" - 8" — 5 1/2" hole diameter  
10" - 12" — 7 1/2" hole diameter

## LD-3510-4GP

Lug/Wafer Butterfly  
Underground Post Assembly \*\*  
(66" standard length)

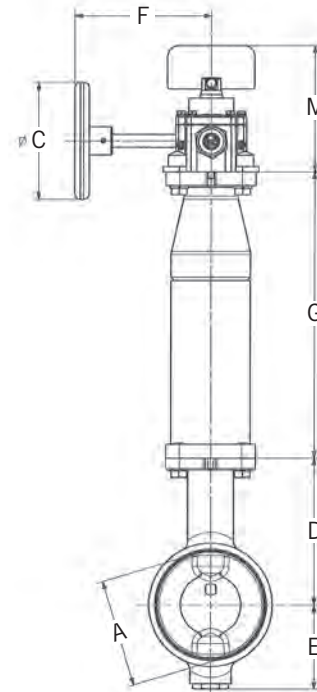

See NIBCO Butterfly Catalog for stem extension information

# Butterfly Post Assembly

## DIMENSIONS—WEIGHTS—QUANTITIES

Valve Size	A		C	D		E		F	G	M	Approx. Net Wt. 22" WP Incl. Wall Plate		
	Grooved	Wafer/Lug		Grooved	Wafer/Lug	Grooved	Wafer/Lug				Grooved	Wafer	Lug
2	—	4.25	6	—	5.38	—	2.88	4.92	A S  R E Q U I R E D	4.6	—	50	51
2½	2.44	4.25	6	4.26	5.88	2.20	3.25	4.92		4.6	51	52	53
3	2.96	4.25	6	4.49	6.13	2.48	3.38	4.92		4.6	53	53	54
4	3.86	4.25	6	5.32	6.88	3.05	4.00	6.5		4.6	56	56	59
5	—	5.17	6	—	7.38	—	4.75	6.5		5.5	—	59	63
6	5.76	6.17	6	7.09	8.00	4.33	5.25	6.5		4.8	—	62	68
8	7.75	8.17	9	8.03	9.25	5.67	6.50	6.5		4.8	76	74	80
10	—	10.17	9	9.84	10.50	6.75	8.00	8.75		5.1	—	91	104
12	—	12.17	9	—	12.00	—	9.25	8.75		5.1	—	108	128

\* 9" x 9" painted steel wall plate included with wall post assembly.

\*\* Ground line to top of indicator should be at least 36".



**WARNING:** This product can expose you to chemicals including lead, which is known to the State of California to cause cancer and birth defects or other reproductive harm. For more information go to [www.P65Warnings.ca.gov](http://www.P65Warnings.ca.gov).

Visit our website for the most current information.

# INSTALLATION, OPERATION, and MAINTENANCE GUIDE

## NIBCO Adjustable Height Upright Indicator Posts

### Series NIP-1AU

NIBCO Series NIP-1AU Adjustable Height Indicator Posts are designed and manufactured to:

- Operate non-rising stem (NRS) post indicator valves (PIV) that are buried underground
- Operate multi-turn post indicator valves (PIV) with an operating range from 10 to 50 turns
- Visually indicate if the underground valve is in the OPEN or SHUT position
- Provide a means to lock the valve into a desired position (usually OPEN)

NIBCO Indicator Posts are listed by Underwriters Laboratories Inc. (UL), Underwriters Laboratories Inc. for use in Canada (C-UL), and approved by Factory Mutual Research Corp. (FM).

It is important to follow the instructions below to assure proper installation and safe trouble-free operation. Failure to follow these instructions may result in reduced product performance and may cause loss of manufacturer's warranty.

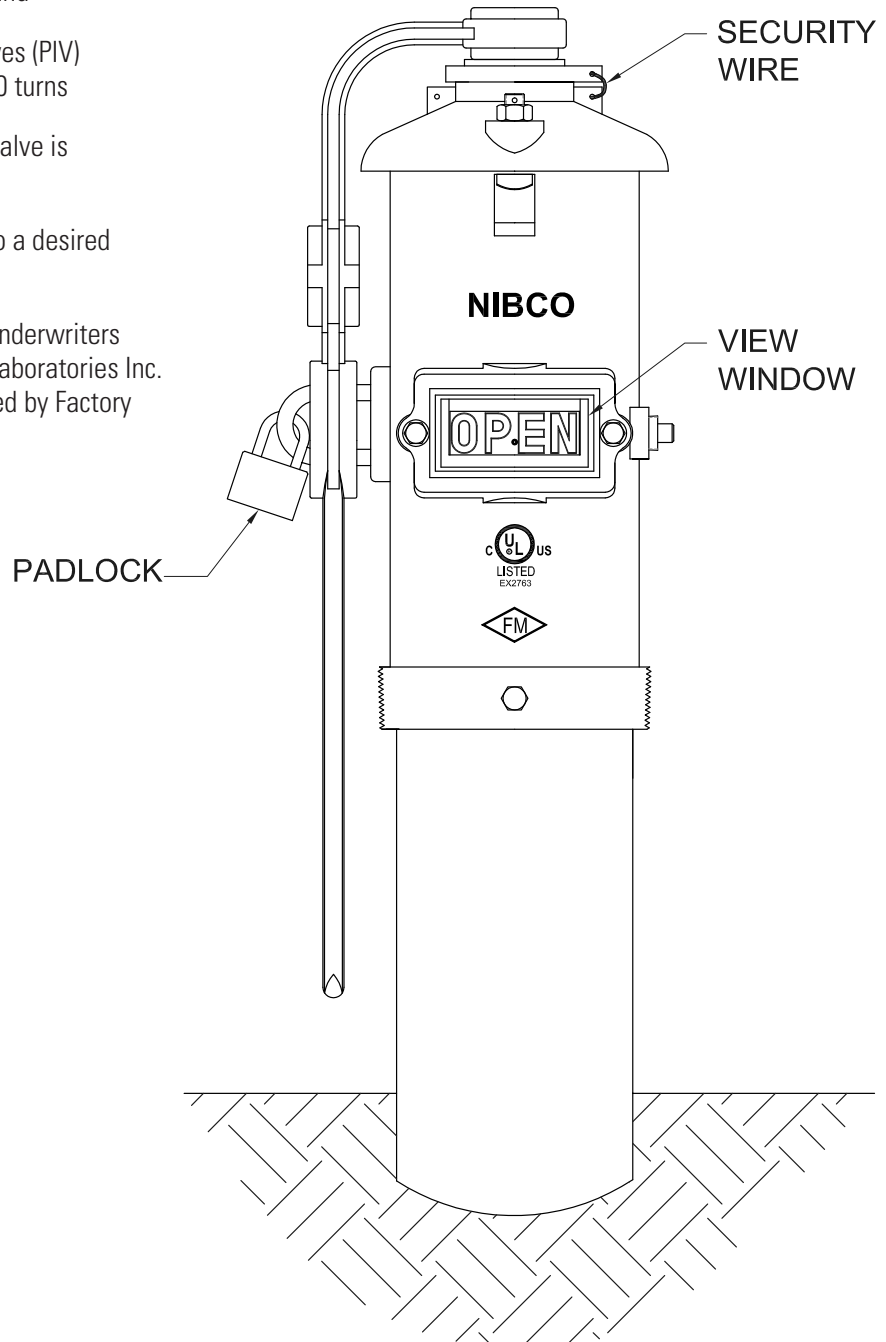

Visit our website for the most current information.

## 1. Application

- 1.1 NIBCO Indicator Posts are primarily used with multi-turn non-rising stem (NRS) post indicator valves (PIV) controlling water supplies to sprinkler, deluge, water spray, foam, and standpipe systems used in fire protection service.
- 1.2 NIBCO Indicator Posts are designed for outdoor service and are coated with electrostatically applied fusion bonded epoxy resin to resist corrosion.
- 1.3 NIBCO Upright Indicator Posts have a 20" adjustment range, and can be ordered to accommodate various bury depths.
- 1.4 NIBCO Indicator Post view targets are adjustable to accommodate valves of various sizes.
- 1.5 NIBCO Indicator Posts are shipped for use with "left-hand" (counter-clockwise) opening valves.
- 1.6 NIBCO Indicator Posts are designed to allow the attachment of a Control Valve Supervisory Switch for electronic monitoring of the OPEN valve position. Simply follow the instructions provided with the Supervisory Switch for proper installation and operation.
- 1.7 NIBCO Upright Indicator Posts are designed to mate and bolt directly to the Post Indicator Valve (PIV) flange; four ¾" holes on a 10½" diameter bolt circle.
- 1.8 Indicator Posts should be inspected on a regular basis.

## 2. Indicator Post Selection

- 2.1 NIBCO Indicator Posts are designed to work with 4" thru 16" size NIBCO Resilient Wedge Gate Valves (RWGVs) and 4" thru 12" sizes NIBCO Iron Body Bronze Mounted (IBBM) Gate Valves. See Table 1 and Fig. 1 for valve dimensional data. They will also work with any manufacturers non-rising stem Post Indicator Valve (PIV) that operates from 10 to 50 turns, and a maximum operating torque of 900 ft-lbs.

### DIMENSIONAL DATA FOR NIBCO RWGV AND IBBM GATE VALVES

VALVE SIZE	NIBCO RESILIENT WEDGE GATE VALVES (RWGV)							NIBCO IRON BODY BRONZE MOUNTED GATE VALVES (IBBM)						
	TURNS TO OPEN	A		B		1/2 PIPE OD		TURNS TO OPEN	A		B		1/2 PIPE OD	
		INCH	MM	INCH	MM	INCH	MM		INCH	MM	INCH	MM	INCH	MM
4"	13	13.46	342	10.12	257	2.40	61	9	14.13	359	10.47	266	2.40	61
6"	15.7	17.01	432	13.78	350	3.45	88	13.5	18.54	471	16.30	414	3.45	88
8"	17.3	20.47	520	17.32	440	4.53	115	17.5	22.13	562	18.11	460	4.53	115
10"	21.4	23.82	605	20.71	526	5.50	140	30.3	25.75	654	21.89	556	5.50	140
12"	25.3	27.01	686	23.86	606	6.60	168	38.3	29.49	749	24.57	624	6.60	168
14"	44	31.81	808	28.58	726	7.65	194							
16"	50	34.21	869	30.98	787	8.70	221							

Table 1

Visit our website for the most current information.

2.2 For Upright Indicator Posts, four Figure No. options are available. See Table 2.

- NIP-1AU, Standard height
- NIP-1AU E, Extended height
- NIP-1AU EE, Double extended height
- NIP-1AU EEE, Triple extended height

See Table 2 for adjustable height ranges, and Table 3 for Bury Depths.

**NIBCO UPRIGHT INDICATOR POST  
ADJUSTABLE HEIGHT RANGE**

ADJUSTABLE HEIGHT RANGE	NIP-1AU		NIP-1AU E		NIP-1AU EE		NIP-1AU EEE	
	H*		H		H		H	
	INCH	MM	INCH	MM	INCH	MM	INCH	MM
MINIMUM	16	406	34	864	52	1321	70	1778
MAXIMUM	36	914	54	1372	72	1829	90	2286

**Table 2**

\*For dimension "H" see Fig. 3

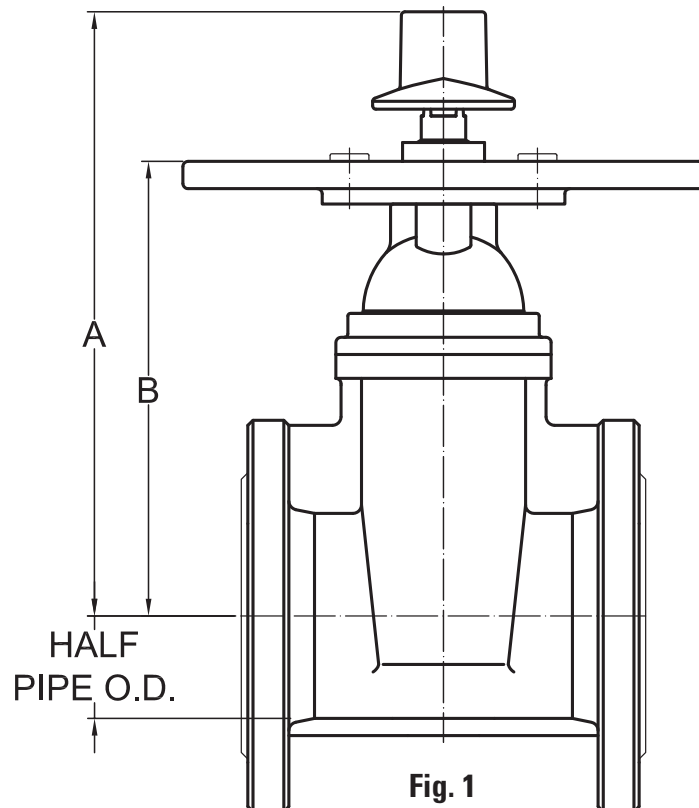

**Fig. 1**

Visit our website for the most current information.

Table 3

**NIBCO UPRIGHT INDICATOR POST VALVE BURY DEPTH**

VALVE SIZE	*ROUNDED ADJUSTABLE BURY DEPTH RANGE	NIBCO RESILIENT WEDGE GATE VALVES (RWGV)							
		NIP-1AU		NIP-1AU E		NIP-1AU EE		NIP-1AU EEE	
		BURY DEPTH		BURY DEPTH		BURY DEPTH		BURY DEPTH	
		INCH	MM	INCH	MM	INCH	MM	INCH	MM
4"	MINIMUM	28	724	46	1181	64	1638	82	2095
	MAXIMUM	48	1232	66	1689	84	2146	102	2603
6"	MINIMUM	33	844	51	1301	69	1758	87	2215
	MAXIMUM	53	1352	71	1809	89	2266	107	2723
8"	MINIMUM	38	961	56	1418	74	1875	92	2332
	MAXIMUM	58	1469	76	1926	94	2383	112	2845
10"	MINIMUM	42	1072	60	1529	78	1986	96	2443
	MAXIMUM	62	1580	80	2037	98	2494	116	2951
12"	MINIMUM	46	1180	64	1637	82	2094	100	2551
	MAXIMUM	66	1688	84	2145	102	2602	120	3059
14"	MINIMUM	52	1326	70	1783	88	2240	106	2697
	MAXIMUM	72	1834	90	2291	108	2748	126	3205
16"	MINIMUM	56	1414	74	1871	92	2328	110	2785
	MAXIMUM	76	1922	94	2379	112	2836	130	3293

\* INCH DIMENSIONS SHOWN ARE ROUNDED TO THE NEAREST INCH

VALVE SIZE	*ROUNDED ADJUSTABLE BURY DEPTH RANGE	NIBCO IRON BODY BRONZE MOUNTED GATE VALVES (IBBM)					
		NIP-1AU		NIP-1AU E		NIP-1AU EE	
		BURY DEPTH		BURY DEPTH		BURY DEPTH	
		INCH	MM	INCH	MM	INCH	MM
4"	MINIMUM	29	733	47	1190	65	1647
	MAXIMUM	49	1241	67	1698	85	2155
6"	MINIMUM	36	908	54	1365	72	1822
	MAXIMUM	56	1416	74	1873	92	2330
8"	MINIMUM	39	981	57	1438	75	1895
	MAXIMUM	59	1489	77	1946	95	2403
10"	MINIMUM	43	1102	61	1559	79	2016
	MAXIMUM	63	1610	81	2067	99	2524
12"	MINIMUM	47	1198	65	1655	83	2112
	MAXIMUM	67	1706	85	2163	103	2620

\* INCH DIMENSIONS SHOWN ARE ROUNDED TO THE NEAREST INCH

Visit our website for the most current information.

### 3. Installation of Upright Style Indicator Post

- 3.1 Fully OPEN the gate valve to which the Indicator Post is being attached.
- 3.2 Loosen but do not remove 2 Body Bolts (35) 3 turns. Remove Barrel (32) and Body Base (31) from inside Center Body (30). Remove Operating Rod (26) from Indicator Post by sliding it out the bottom, See Fig. 2.
- 3.3 Position Body Base (31) on top of buried valve PIV plate and secure with 4 customer supplied bolts, washers, & nuts, See Fig. 3.
- 3.4 Remove Bolt (28), Flatwasher (38), and Lockwasher (39) from Upper Body (1) and lift Head Assembly from Center Body (30).
- 3.5 Slide Center Body (30) over Barrel (32) and slide down until BURY line cast on Center Body is even with planned finished grade soil level. Securely tighten 2 Body Bolts (35). See Fig. 2 & 3.
- 3.6 Insert 1" square Operating Rod (26) with attached Coupling (25) inside Barrel (32) and fully engage Coupling onto Operating Nut of valve as shown in Fig. 3. Mark Operating Rod at a distance 10¾" from top edge of Center Body (30), See Fig. 4. Remove Operating Rod (26) from Barrel (32) and cut off the top section of the 1" square Rod at location you just marked. Remove any sharp edges from the Rod with a file.
- 3.7 Reinstall the shortened Operating Rod (26) into Barrel (32), making sure the Coupling (25) is fully engaged on Operating Nut of valve, See Fig. 3.
- 3.8 Reinstall the Head Assembly by sliding the 1" square pocket located in bottom side of Head Assembly onto Operating Rod (26). Secure Head Assembly to Center Body (30) with Screw (28), Flatwasher (38), and Lockwasher (39).

*Visit our website for the most current information.*

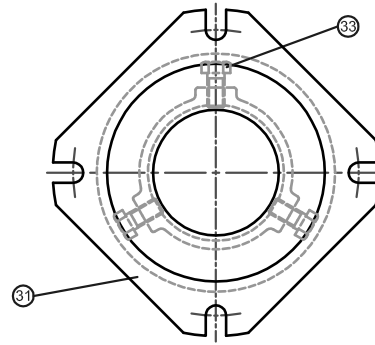
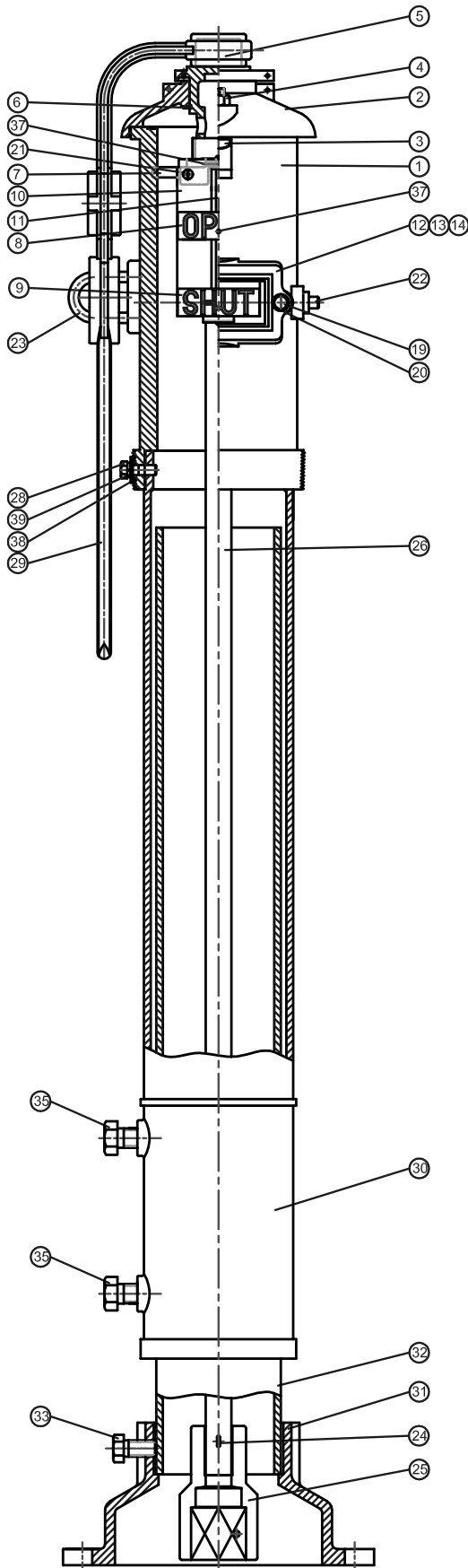

**Table 4**

**UPRIGHT STYLE INDICATOR POST PARTS LIST**

NO.	DESCRIPTION	MATERIAL	SPECIFICATION	QTY.
1	UPPER BODY	DUCTILE IRON	ASTM A536 Gr. 65-45-12	1
2	CAP	DUCTILE IRON	ASTM A536 Gr. 65-45-12	1
3	T-HEAD BOLT, CAP	STEEL, ZINC PLATED	ASTM A105	2
4	NUT, CAP	STEEL, ZINC PLATED	ASTM A105	2
5	OPERATING STEM	BRONZE	ASTM B584 C84400 / B62 C83600	1
6	RETAINING RING, STEM	STAINLESS STEEL	ASTM A276 S30400	1
7	LEADING BOGIE	BRONZE	ASTM B584 C84400 / B62 C83600	1
8	TARGET PLATE, OPEN	ALUMINUM	ASTM B26	2
9	TARGET PLATE, CLOSED	ALUMINUM	ASTM B26	2
10	EXTENSION PLATE	STEEL, PAINTED BLACK	ASTM A1008	2
11	TARGET ROD	BRASS	ASTM B16 C36000	2
12	VIEW WINDOW	POLYCARBONATE	COMMERCIAL	2
13	GASKET, WINDOW	RUBBER	ASTM D2000 EPDM	2
14	GUARD, WINDOW	CAST IRON	ASTM B124 Gr. B	2
19	SCREW, HEX HEAD CAP	STAINLESS STEEL	S30400	4
20	WASHER	STAINLESS STEEL	S30400	4
21	SCREW, SLOTTED FLAT HD.	STAINLESS STEEL	S30400	4
22	PLUG, 1/2" PIPE	STEEL, ZINC PLATED	COMMERCIAL	1
23	U-BOLT	FORGED STEEL	ASTM A105	1
24	COTTER PIN	STAINLESS STEEL	S30400	1
25	COUPLING, OPERATING ROD	DUCTILE IRON	ASTM A536 Gr. 65-45-12	1
26	OPERATING ROD	STEEL	ASTM A105	1
28	SCREW, HEX HEAD CAP	STAINLESS STEEL	S30400	1
29	WRENCH, OPERATING	DUCTILE IRON	ASTM A536 Gr. 65-45-12	1
30	CENTER BODY	DUCTILE IRON	ASTM A536 Gr. 65-45-12	1
31	BASE BODY	DUCTILE IRON	ASTM A536 Gr. 65-45-12	1
32	BARREL	DUCTILE IRON	ASTM A536 Gr. 65-45-12	1
33	SCREW, HEX HEAD CAP	STAINLESS STEEL	S30400	3
35	SCREW, HEX HEAD CAP	STAINLESS STEEL	S30400	2
37	SCREW, SOCKET HD. SET	STAINLESS STEEL	S30400	6
38	WASHER, FLAT	STAINLESS STEEL	S30400	1
39	WASHER, LOCK	STAINLESS STEEL	S30400	1

**Fig. 2**

Visit our website for the most current information.

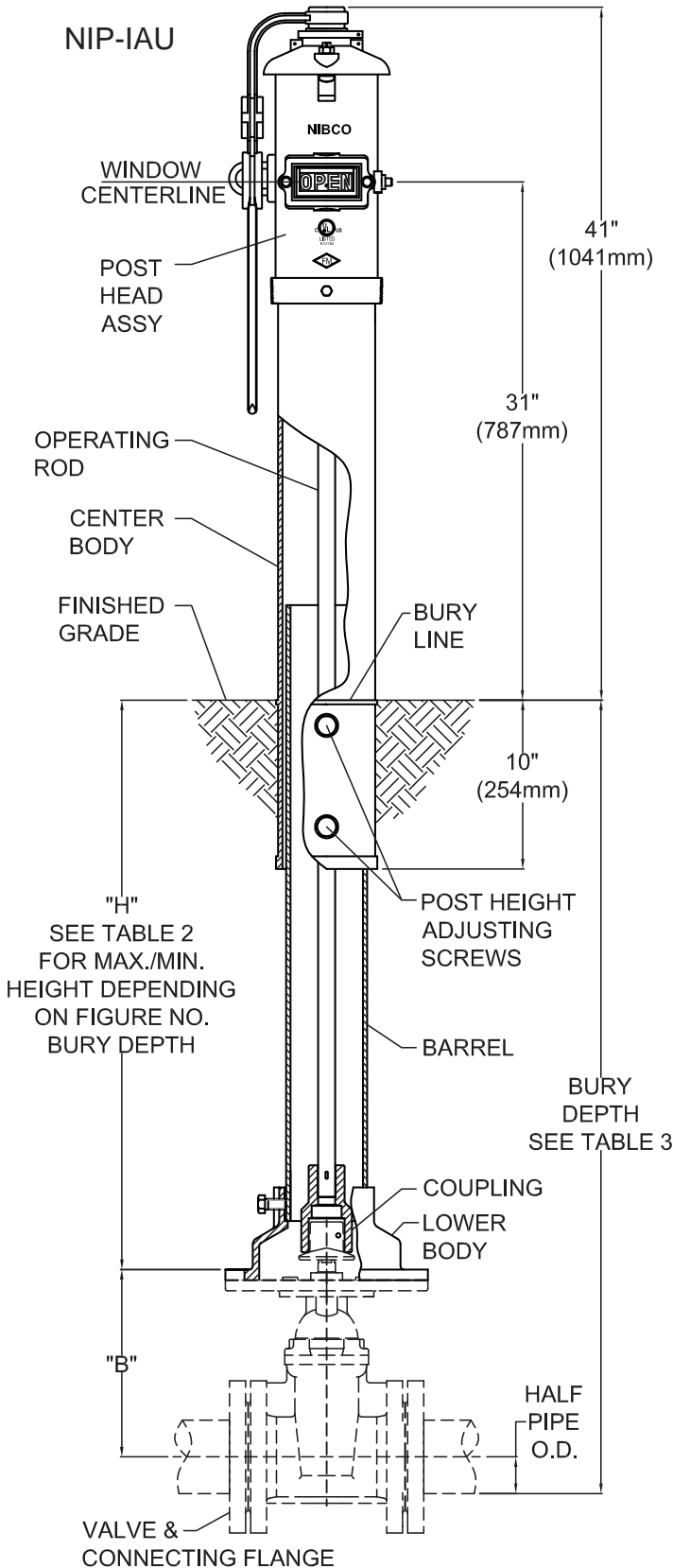

**Fig. 3**

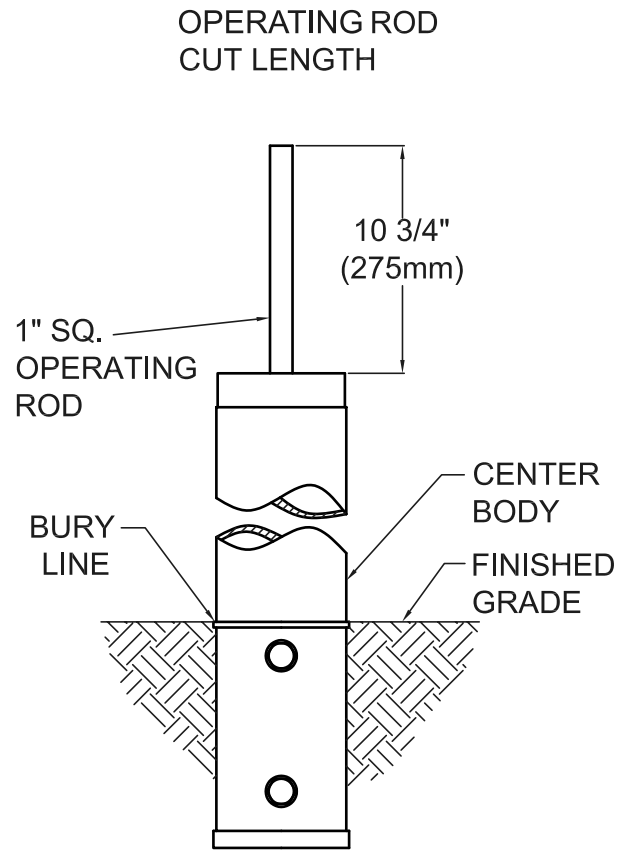

**Fig. 4**

**4. OPEN and SHUT Target Adjustment**

- 4.1 All NIBCO Indicator Posts are shipped for use with "left-hand" (counter-clockwise) opening valves.
- 4.2 Remove two Nuts (4) and two T-Head Bolts (3) that secure Cap (2) to Indicator Post. See Fig. 2.
- 4.3 Grasp Cap (2) and remove from Indicator Post by lifting upward until Target assembly is clear.
- 4.4 Target Plates (8 & 9) must be positioned with the OPEN Plate (8) above the SHUT Plate (9) for "left-hand" (counter-clockwise) opening valves. See Fig. 5.

Visit our website for the most current information.

**Table 5**

**TARGET ASSEMBLY PARTS LIST**

NO.	DESCRIPTION	MATERIAL	SPECIFICATION	QTY.
7	LEADING BOGIE	BRONZE	ASTM B584 C84400 / B62 C83600	1
8	TARGET PLATE, OPEN	ALUMINUM	ASTM B26	2
9	TARGET PLATE, SHUT	ALUMINUM	ASTM B26	2
10	EXTENSION PLATE	STEEL, PAINTED BLACK	ASTM A1008	2
11	TARGET ROD	BRASS	ASTM B16 C36000	2
21	SCREW, SLOTTED FLAT HD.	STAINLESS STEEL	S30400	4
37	SCREW, SOCKET HD. SET	STAINLESS STEEL	S30400	6

**TARGET ASSEMBLY**

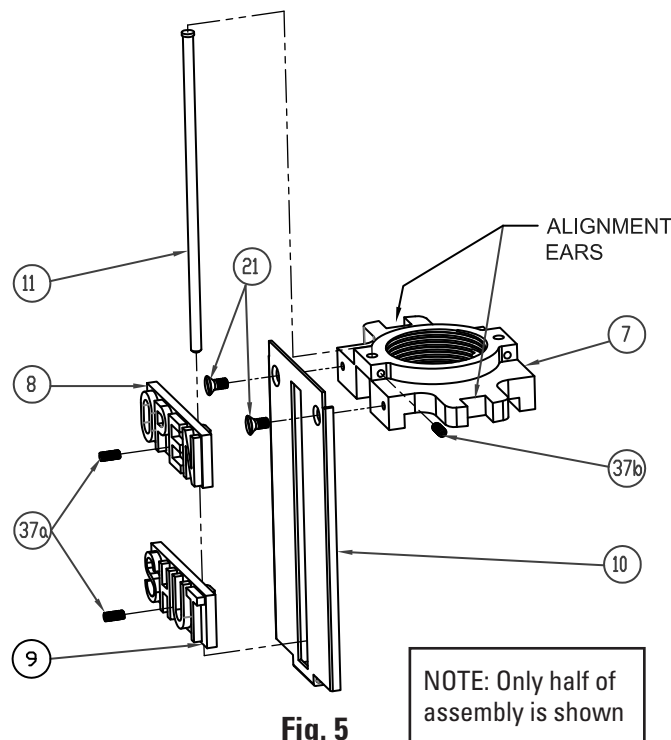

- 4.5 Position OPEN Target Plates (8) so they are in the full upward position for “left-hand” (counter-clockwise) opening valves. Secure OPEN Target Plates (8) by tightening Screws (37a). See Fig. 6.
- 4.6 Determine the number of turns required to fully open the valve. See Table 1 for NIBCO valves. You should always confirm actual turns required to open the valve by counting them.
- 4.7 Using Table 6, choose the closest “Number of Turns to Open Valve” and the corresponding “Distance Between Targets” dimension “X”.
- 4.8 Measure and position both SHUT Target Plates (9) at dimension “X” from OPEN Target Plates (8). See Fig. 6.
- 4.9 Secure both SHUT Target Plates (9) by tightening Screws (37a) with an Allen wrench.

Visit our website for the most current information.

Table 6

## ADJUSTMENT OF TARGET PLATES

NUMBER OF TURNS TO OPEN VALVE	DISTANCE BETWEEN TARGETS	
	X	
	INCH	MM
10	0.000	0.0
11	0.050	1.3
12	0.150	3.8
13	0.250	6.4
14	0.350	8.9
15	0.450	11.4
16	0.550	14.0
17	0.650	16.5
18	0.750	19.1
19	0.850	21.6
20	0.950	24.1
21	1.050	26.7
22	1.150	29.2
23	1.250	31.8

NUMBER OF TURNS TO OPEN VALVE	DISTANCE BETWEEN TARGETS	
	X	
	INCH	MM
24	1.350	34.3
25	1.450	36.8
26	1.550	39.4
27	1.650	41.9
28	1.750	44.5
29	1.850	47.0
30	1.950	49.5
31	2.050	52.1
32	2.150	54.6
33	2.250	57.2
34	2.350	59.7
35	2.450	62.2
36	2.550	64.8
37	2.650	67.3

NUMBER OF TURNS TO OPEN VALVE	DISTANCE BETWEEN TARGETS	
	X	
	INCH	MM
38	2.750	69.9
39	2.850	72.4
40	2.950	74.9
41	3.050	77.5
42	3.150	80.0
43	3.250	82.6
44	3.350	85.1
45	3.450	87.6
46	3.550	90.2
47	3.650	92.7
48	3.750	95.3
49	3.850	97.8
50	3.950	100.3
51	4.050	102.9

## POSITIONING OF OPEN TARGET PLATES FOR VIEW WINDOW

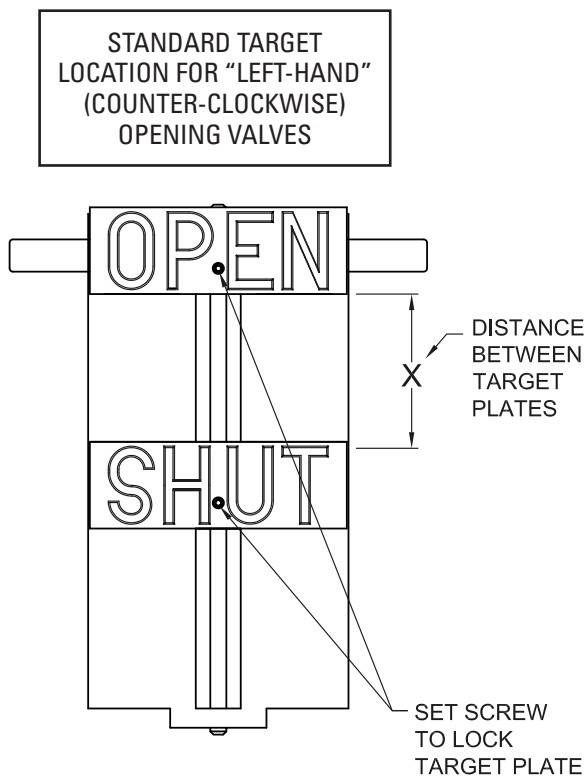

Fig. 6

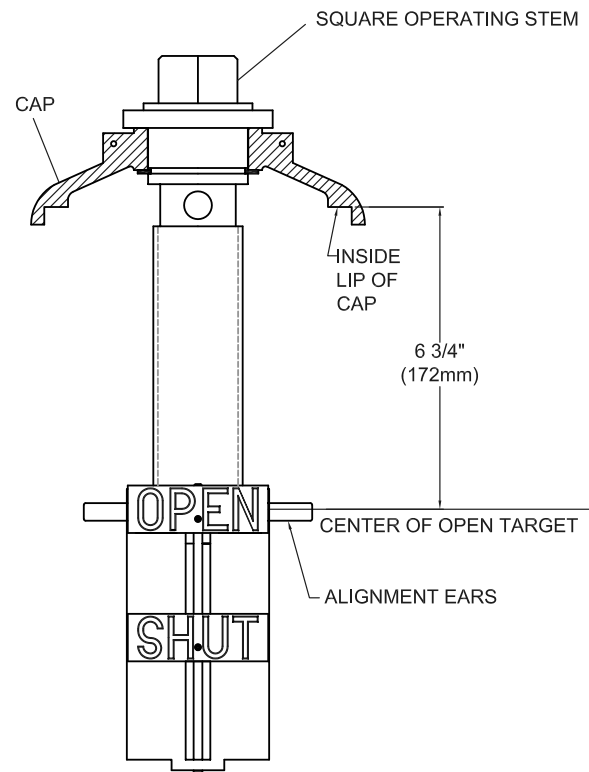

Fig. 7

Visit our website for the most current information.

## 6. Positioning of Targets in View Window

- 6.1 Rotate Square Operating Stem (5) positioning the center of the OPEN Target Plate (8) until it is located 6¾" from the inside lip of Cap (2). See Fig. 7.
- 6.2 Verify that the valve is in full OPEN position.
- 6.3 Reinstall the Cap (2) & Target assembly into the Upper Body (1) making sure both alignment ears on bronze Leading Bogie (7) straddle the guides cast on the inside of the Upper Body. See Fig. 2.
- 6.4 Reinstall 2 T-Head Bolts (3) in Cap and secure with 2 Nuts (4).
- 6.5 Check to assure that the OPEN Target Plate (8) is centered in both sides of the view window.

## 7. Operation

- 7.1 The post indicator valve (PIV) can be opened or shut by simply placing the Operating Wrench (29) onto Operating Stem (5) and rotating in the desired direction. To open the valve, simply turn the wrench in the counter-clockwise direction as indicated on Cap (2). To shut the valve, simply turn the wrench in the clockwise direction. See Fig. 2.
- 7.2 The Target Plates (8) (9) can be visually checked in the view windows to determine if PIV is open or shut.
- 7.3 After installation, the PIV should be cycled to the full shut position and both view windows should be visually inspected to assure the SHUT target plates are centered. The PIV should then be cycled to the full open position and both view windows should be visually inspected to assure the OPEN target plates are centered.
- 7.4 Valve position can be secured by simply placing the Operating Wrench (29) over the Operating Stem (5) and over U-bolt (23). A customer supplied lock can be installed into the U-bolt securing Operating Wrench to the indicator post, preventing valve operation.
- 7.5 NIBCO Indicator Posts have provisions to add a Security Wire thru the Cap T-bolts (3) and Operating Stem (5) to prevent valve operation.

## 8. Maintenance

- 8.1 Lubrication should be added to oil hole located in top of Operating Stem (5) on an annual basis. Note: it is necessary to remove the Operating Wrench (29) to expose the oil hole.
- 8.2 Periodic visual inspection is recommended.
- 8.3 Exercising (cycling) of the valve to assure proper function is recommended.

## 9. Repair Parts

- 9.1 Some specialty components are available for replacement if needed. See Table 7.
- 9.2 Common fasteners such as nuts, bolts, and washers are available at your local hardware.

**Table 7 REPAIR PARTS ADJUSTABLE HEIGHT UPRIGHT STYLE**

NO.	DESCRIPTION	PART NO.
3	T-HEAD BOLT	NP1AU10
12	VIEW WINDOW	NP1AU06
13	WINDOW GASKET	NP1AU09
14	WINDOW GUARD	NP1AU07
24	COTTER PIN	NP1AU21

NO.	DESCRIPTION	PART NO.
25	OPERATING ROD COUPLING	NP1AU22
26	OPERATING ROD 72"	NP1AU16
26	OPERATING ROD 90"	NP1AU16E
26	OPERATING ROD 108"	NP1AU16EE
26	OPERATING ROD 126"	NP1AU16EEE
29	OPERATING WRENCH	NP1AU17

Visit our website for the most current information.

# INSTALLATION, OPERATION, and MAINTENANCE GUIDE

## NIBCO Wall Mount Indicator Posts

### Series NIP-2AW

- NIBCO Series NIP-2AW Wall Mount Indicator Posts are designed and manufactured to:
- Operate non-rising stem (NRS) post indicator valves (PIV) located through building walls
- Operate multi-turn post indicator valves (PIV) with an operating range from 10 to 50 turns
- Visually indicate if the valve is in the OPEN or SHUT position
- Provide a means to lock the valve into a desired position (usually OPEN)

NIBCO Indicator Posts are listed by Underwriters Laboratories Inc. (UL), Underwriters Laboratories Inc. for use in Canada (C-UL), and approved by Factory Mutual Research Corp. (FM).

It is important to follow the instructions below to assure proper installation and safe trouble-free operation. Failure to follow these instructions may result in reduced product performance and may cause loss of manufacturer's warranty.

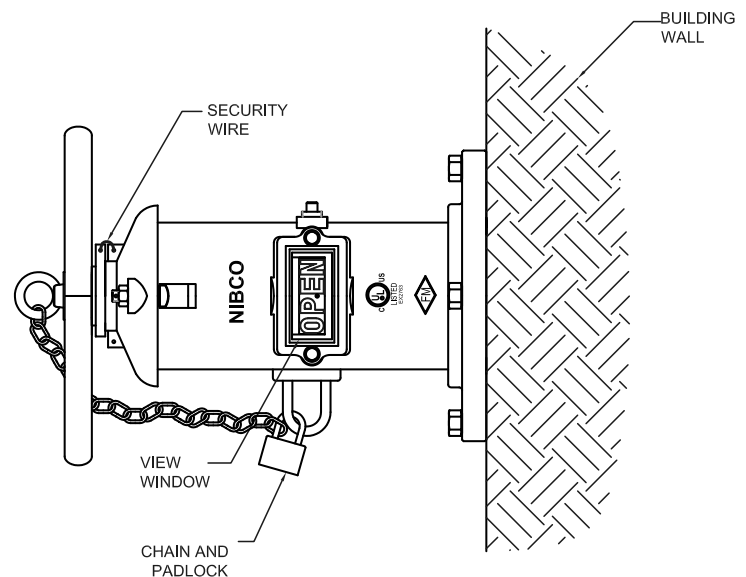

## 1. Application

- 1.1 NIBCO Indicator Posts are primarily used with multi-turn non-rising stem (NRS) post indicator valves (PIV) controlling water supplies to sprinkler, deluge, water spray, foam, and standpipe systems used in fire protection service.
- 1.2 NIBCO Indicator Posts are designed for outdoor service and are coated with electrostatically applied fusion bonded epoxy resin to resist corrosion.
- 1.3 NIBCO Indicator Post view targets are adjustable to accommodate valves of various sizes.
- 1.4 NIBCO Indicator Posts are shipped for use with "left-hand" (counter-clockwise) opening valves.
- 1.5 NIBCO Indicator Posts are designed to allow the attachment of a Control Valve Supervisory Switch for electronic monitoring of the OPEN valve position. Simply follow the instructions provided with the Supervisory Switch for proper installation and operation.
- 1.6 NIBCO Wall Indicator Posts are designed to attach directly to the exterior of the building wall; four 3/4" holes on a 10 1/2" diameter bolt circle.
- 1.7 Indicator Posts should be inspected on a regular basis.

Visit our website for the most current information.

## 2. Indicator Post Selection

- 2.1 NIBCO Indicator Posts are designed to work with 4" thru 16" size NIBCO Resilient Wedge Gate Valves (RWGVs) and 4" thru 12" sizes NIBCO Iron Body Bronze Mounted (IBBM) Gate Valves. See Table 1 and Fig. 1 for valve dimensional data. They will also work with any manufacturers non-rising stem Post Indicator Valve (PIV) that operates from 10 to 50 turns, and a maximum operating torque of 900 ft-lbs.

### DIMENSIONAL DATA FOR NIBCO RWGV AND IBBM GATE VALVES

VALVE SIZE	NIBCO RESILIENT WEDGE GATE VALVES (RWGV)							NIBCO IRON BODY BRONZE MOUNTED GATE VALVES (IBBM)						
	TURNS TO OPEN	A		B		1/2 PIPE OD		TURNS TO OPEN	A		B		1/2 PIPE OD	
		INCH	MM	INCH	MM	INCH	MM		INCH	MM	INCH	MM	INCH	MM
4"	13	13.46	342	10.12	257	2.40	61	9	14.13	359	10.47	266	2.40	61
6"	15.7	17.01	432	13.78	350	3.45	88	13.5	18.54	471	16.30	414	3.45	88
8"	17.3	20.47	520	17.32	440	4.53	115	17.5	22.13	562	18.11	460	4.53	115
10"	21.4	23.82	605	20.71	526	5.50	140	30.3	25.75	654	21.89	556	5.50	140
12"	25.3	27.01	686	23.86	606	6.60	168	38.3	29.49	749	24.57	624	6.60	168
14"	44	31.81	808	28.58	726	7.65	194							
16"	50	34.21	869	30.98	787	8.70	221							

Table 1

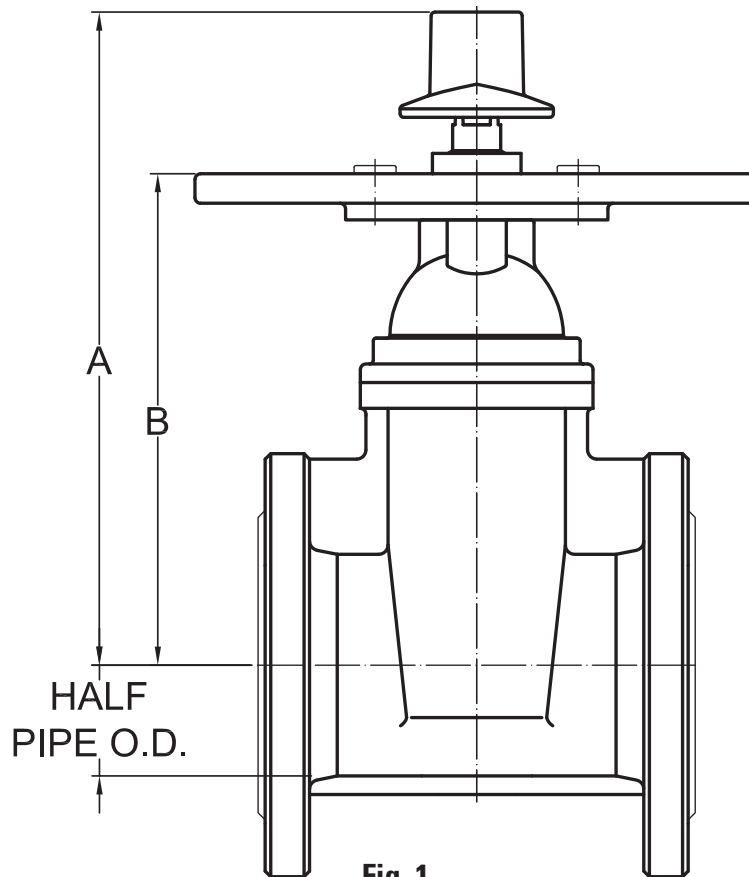
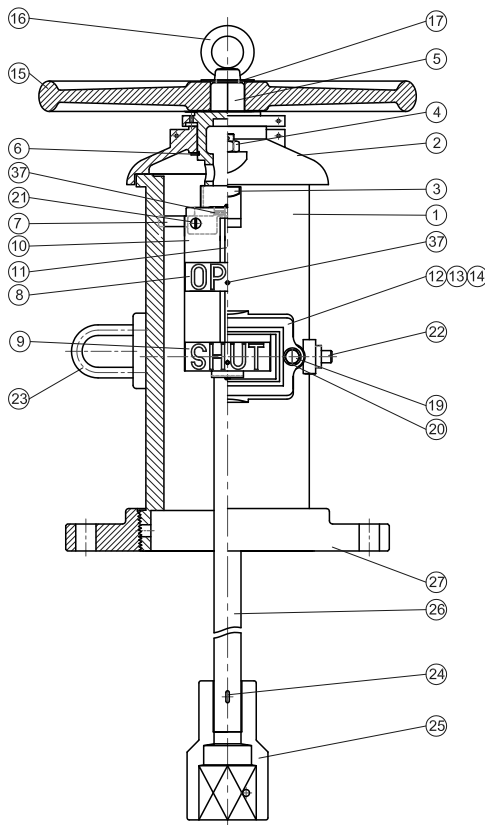

Fig. 1

Visit our website for the most current information.

### 3. Installation of Wall Mount Style Indicator Post

- 3.1 Fully OPEN the gate valve to which the Indicator Post is being attached.
- 3.2 Remove 1" square Operating Rod (26) with attached Coupling (25) from Indicator Post by sliding it out from bottom, See Fig. 2.
- 3.3 Insert Operating Rod (26) thru exterior wall and fully engage Coupling onto Operating Nut of Valve as shown in Fig. 3. Mark the Operating Rod (26) at a distance of 12¼" from exterior face of wall. Remove Operating Rod (26) from wall and cut-off the top section of the 1" square Rod at location you just marked. Remove any sharp edges from the Rod with a file.
- 3.4 Reinstall the shortened Operating Rod (26) into the Wall Indicator Post by sliding it into the 1" square pocket in bottom side, See Fig. 2.
- 3.5 Lift Wall Indicator Post assembly and insert Operating Rod (26) thru exterior wall and fully engage Coupling (25) onto Operating Nut of valve as shown in Fig. 4. Rotate and Orient Wall Post assembly until desired location of View Windows is obtained. Align and level Operating Rod with valve Operating Nut then mark position of 4 wall mounting holes thru Flange (27).
- 3.6 Remove Wall Indicator Post assembly from the wall. Drill exterior wall as marked for appropriate size (customer supplied) mounting bolts.
- 3.7 Reinstall Wall Indicator Post assembly onto wall making sure the Coupling (25) is fully engaged on Operating Nut of valve. Secure Post assembly to wall with 4 bolts.



**Fig. 2**

**Table 2**

### WALL MOUNT STYLE INDICATOR POST PARTS LIST

NO.	DESCRIPTION	MATERIAL	SPECIFICATION	QTY.
1	UPPER BODY	DUCTILE IRON	ASTM A536 Gr. 65-45-12	1
2	CAP	DUCTILE IRON	ASTM A536 Gr. 65-45-12	1
3	T-HEAD BOLT, CAP	STEEL, ZINC PLATED	ASTM A105	2
4	NUT, CAP	STEEL, ZINC PLATED	ASTM A105	2
5	OPERATING STEM	BRONZE	ASTM B584 C84400 / B62 C83600	1
6	RETAINING RING, STEM	STAINLESS STEEL	ASTM A276 S30400	1
7	LEADING BOGIE	BRONZE	ASTM B584 C84400 / B62 C83600	1
8	TARGET PLATE, OPEN	ALUMINUM	ASTM B26	2
9	TARGET PLATE, SHUT	ALUMINUM	ASTM B26	2
10	EXTENSION PLATE	STEEL, PAINTED BLACK	ASTM A1008	2
11	TARGET ROD	BRASS	ASTM B16 C36000	2
12	VIEW WINDOW	POLYCARBONATE	COMMERCIAL	2
13	GASKET, WINDOW	RUBBER	ASTM D2000 EPDM	2
14	GUARD, WINDOW	CAST IRON	ASTM B124 Gr. B	2
15	HANDWHEEL	DUCTILE IRON	ASTM A536 Gr. 65-45-12	1
16	EYEBOLT, HANDWHEEL	FORGED STEEL, ZINC PL.	ASTM A105	1
17	WASHER, H.W. RETAINER	STEEL, ZINC PLATED	COMMERCIAL	1
19	SCREW, HEX HEAD CAP	STAINLESS STEEL	S30400	4
20	WASHER	STAINLESS STEEL	S30400	4
21	SCREW, SLOTTED FLAT HD.	STAINLESS STEEL	S30400	4
22	PLUG, 1/2" PIPE	STEEL, ZINC PLATED	COMMERCIAL	1
23	U-BOLT	FORGED STEEL	ASTM A105	1
24	COTTER PIN	STAINLESS STEEL	S30400	1
25	COUPLING, OPERATING ROD	DUCTILE IRON	ASTM A536 Gr. 65-45-12	1
26	OPERATING ROD	STEEL	ASTM A105	1
27	FLANGE, THREADED	DUCTILE IRON	ASTM A536 Gr. 65-45-12	1
37	SCREW, SOCKET HD. SET	STAINLESS STEEL	S30400	6

Visit our website for the most current information.

## INSTALLATION LAYOUT

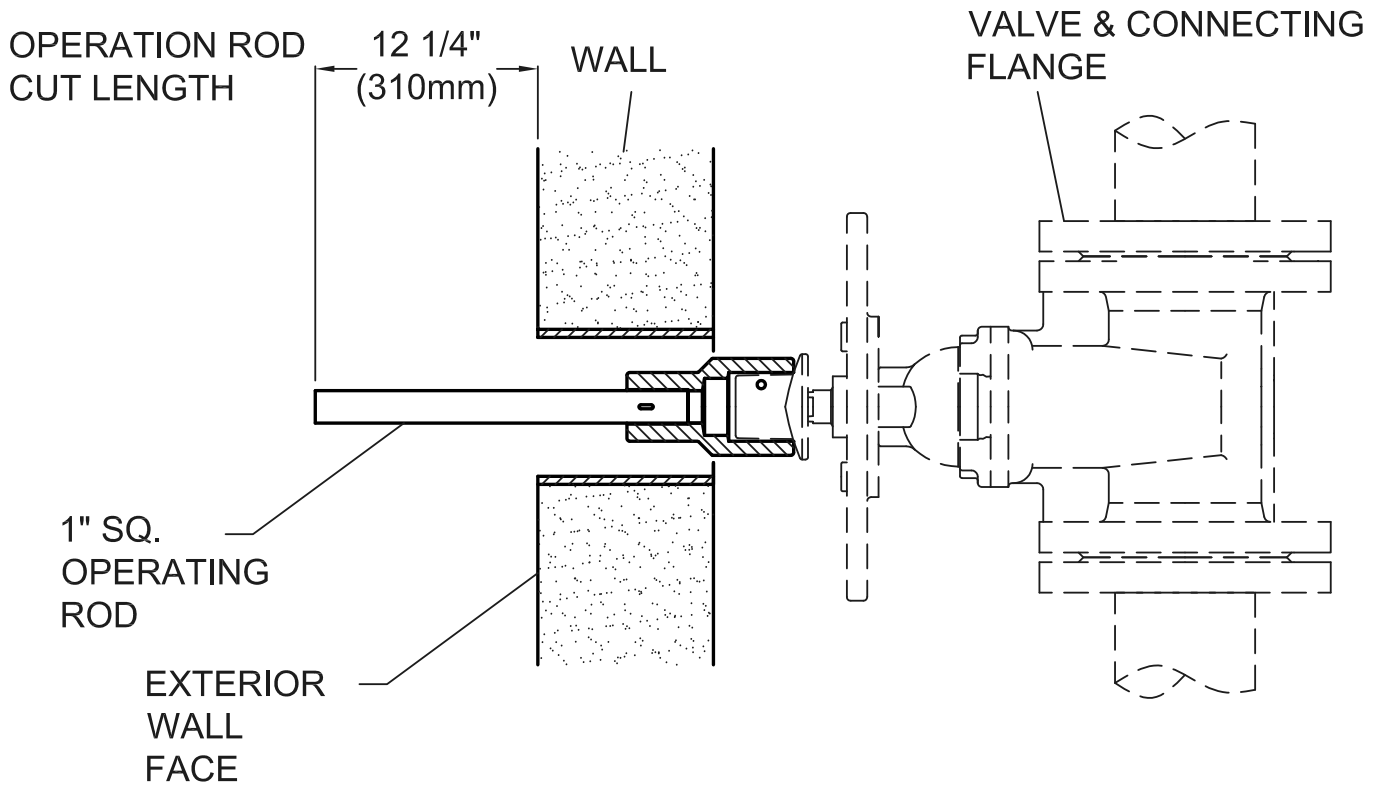

Fig. 3

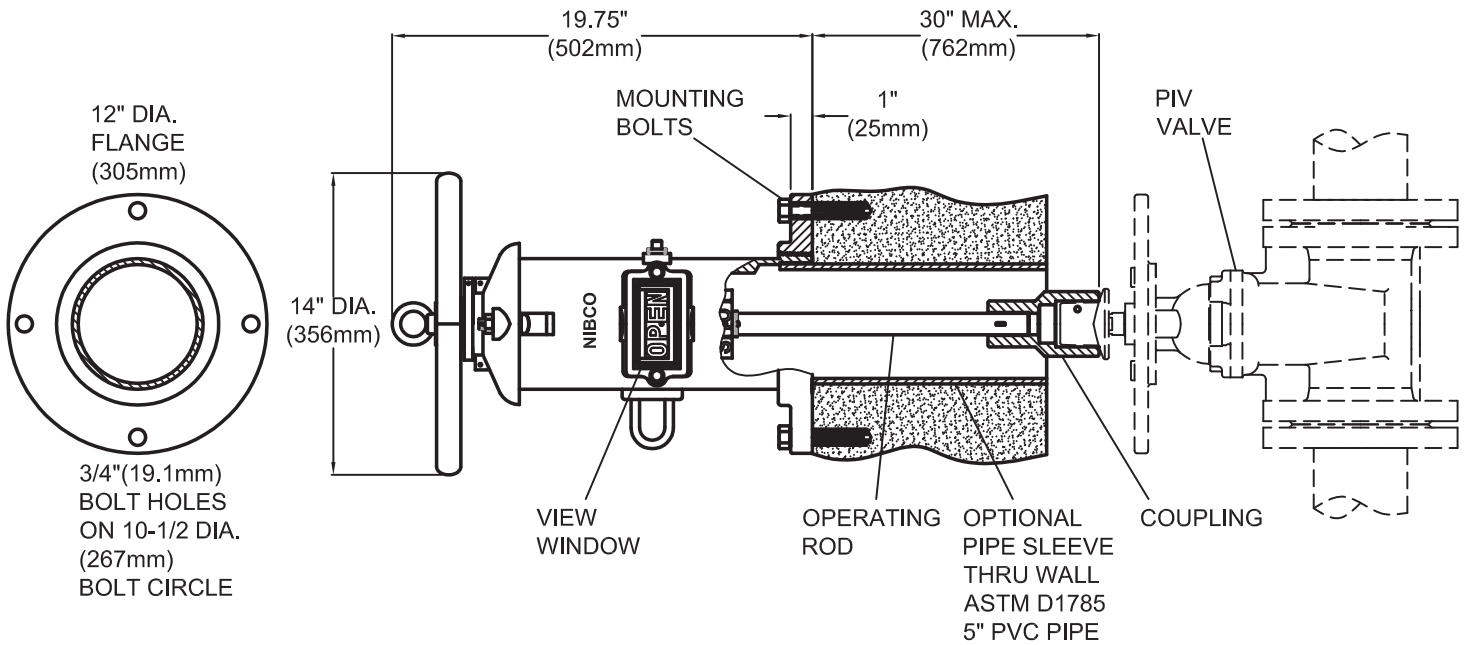

Fig. 4

Visit our website for the most current information.

**4. OPEN and SHUT Target Adjustment**

- 4.1 All NIBCO Indicator Posts are shipped for use with “left-hand” (counter-clockwise) opening valves.
- 4.2 Remove 2 Nuts (4) and 2 T-Head Bolts (3) that secure Cap (2) to Indicator Post. See Fig. 2.
- 4.3 Grasp Cap (2) and remove from Indicator Post by lifting upward until Target assembly is clear.
- 4.4 Target Plates (8 & 9) must be positioned with the OPEN Plate (8) above the SHUT Plate (9) for “left-hand” (counter-clockwise) opening valves. See Fig. 5.

**Table 3**

**TARGET ASSEMBLY PARTS LIST**

NO.	DESCRIPTION	MATERIAL	SPECIFICATION	QTY.
7	LEADING BOGIE	BRONZE	ASTM B584 C84400 / B62 C83600	1
8	TARGET PLATE, OPEN	ALUMINUM	ASTM B26	2
9	TARGET PLATE, SHUT	ALUMINUM	ASTM B26	2
10	EXTENSION PLATE	STEEL, PAINTED BLACK	ASTM A1008	2
11	TARGET ROD	BRASS	ASTM B16 C36000	2
21	SCREW, SLOTTED FLAT HD.	STAINLESS STEEL	S30400	4
37	SCREW, SOCKET HD. SET	STAINLESS STEEL	S30400	6

**TARGET ASSEMBLY**

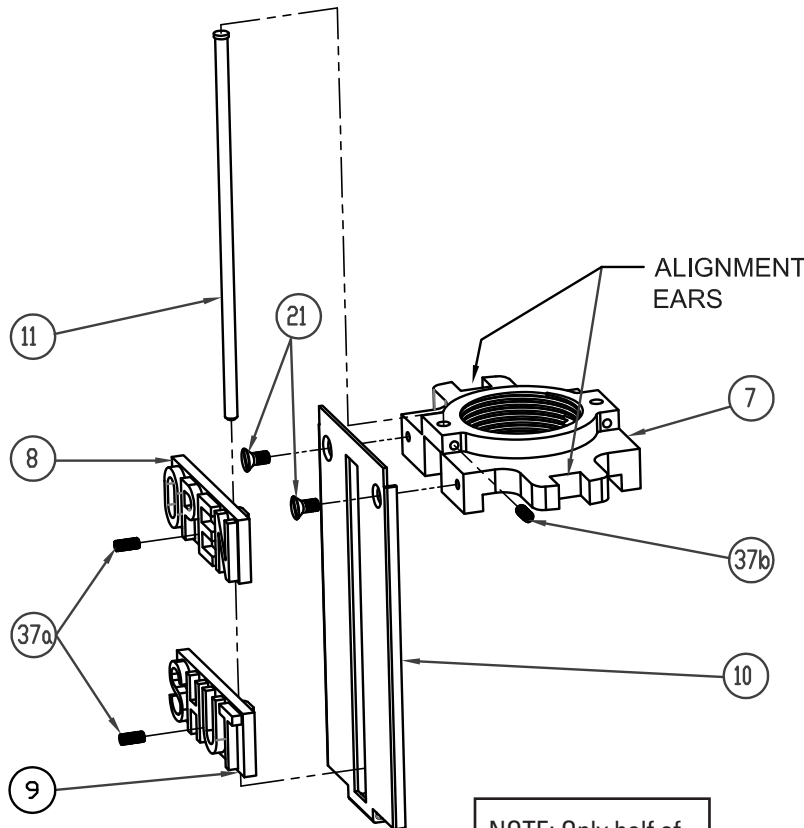

**Fig. 5**

NOTE: Only half of assembly is shown

Visit our website for the most current information.

- 4.5 Position OPEN Target Plates (8) so they are in the full upward position for “left-hand” (counter-clockwise) opening valves. Secure OPEN Target Plates (8) by tightening Screws (37a). See Fig. 6.
- 4.6 Determine the number of turns required to fully open the valve. See Table 1 for NIBCO valves. You should always confirm actual turns required to open the valve by counting them.
- 4.7 Using Table 6, choose the closest “Number of Turns to Open Valve” and the corresponding “Distance Between Targets” dimension “X”.
- 4.8 Measure and position both SHUT Target Plates (9) at dimension “X” from OPEN Target Plates (8). See Fig. 6.
- 4.9 Secure both SHUT Target Plates (9) by tightening Screws (37a) with an Allen wrench.

**Table 4**

## ADJUSTMENT OF TARGET PLATES

NUMBER OF TURNS TO OPEN VALVE	DISTANCE BETWEEN TARGETS	
	X	
	INCH	MM
10	0.000	0.0
11	0.050	1.3
12	0.150	3.8
13	0.250	6.4
14	0.350	8.9
15	0.450	11.4
16	0.550	14.0
17	0.650	16.5
18	0.750	19.1
19	0.850	21.6
20	0.950	24.1
21	1.050	26.7
22	1.150	29.2
23	1.250	31.8

NUMBER OF TURNS TO OPEN VALVE	DISTANCE BETWEEN TARGETS	
	X	
	INCH	MM
24	1.350	34.3
25	1.450	36.8
26	1.550	39.4
27	1.650	41.9
28	1.750	44.5
29	1.850	47.0
30	1.950	49.5
31	2.050	52.1
32	2.150	54.6
33	2.250	57.2
34	2.350	59.7
35	2.450	62.2
36	2.550	64.8
37	2.650	67.3

NUMBER OF TURNS TO OPEN VALVE	DISTANCE BETWEEN TARGETS	
	X	
	INCH	MM
38	2.750	69.9
39	2.850	72.4
40	2.950	74.9
41	3.050	77.5
42	3.150	80.0
43	3.250	82.6
44	3.350	85.1
45	3.450	87.6
46	3.550	90.2
47	3.650	92.7
48	3.750	95.3
49	3.850	97.8
50	3.950	100.3
51	4.050	102.9

Visit our website for the most current information.

## POSITIONING OF OPEN TARGET PLATES FOR VIEW WINDOW

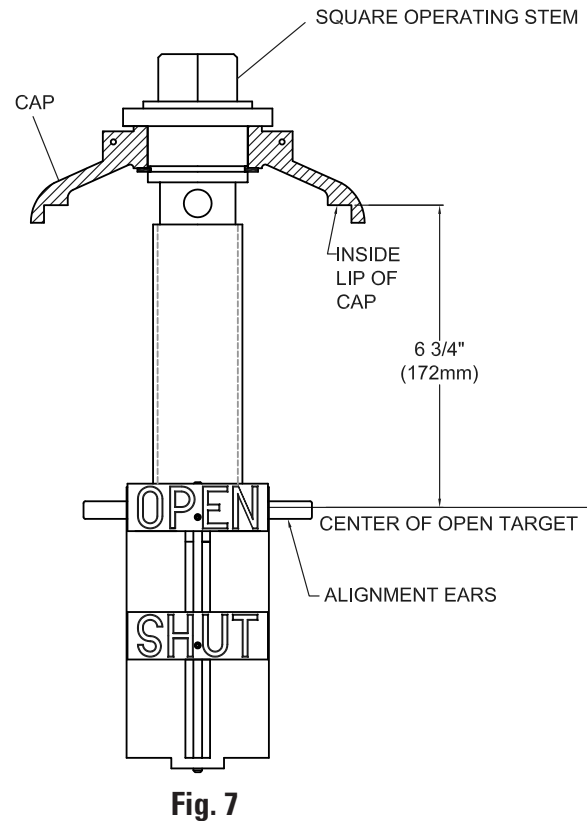
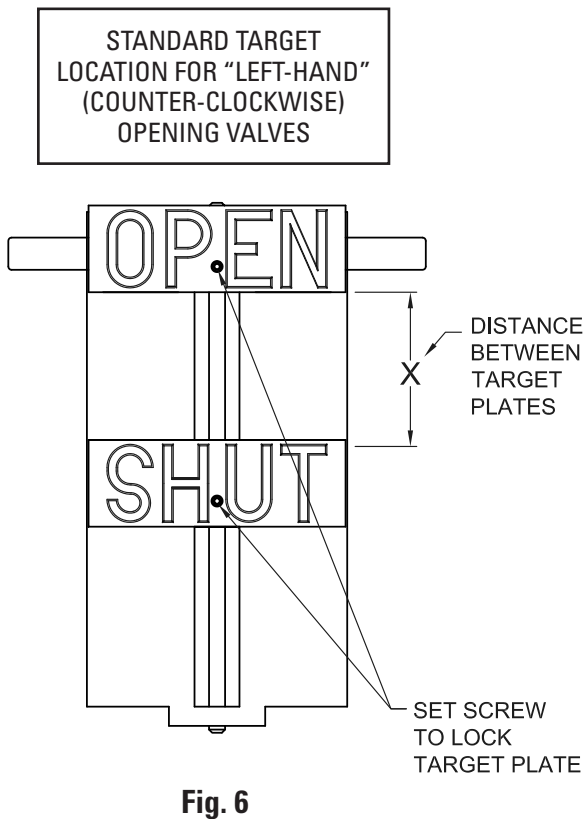

### 6. Positioning of Targets in View Window

- 6.1 Rotate Square Operating Stem (5) positioning the center of the OPEN Target Plate (8) until it is located 6¾" from the inside lip of Cap (2). See Fig. 7.
- 6.2 Verify that the valve is in full OPEN position.
- 6.3 Reinstall the Cap (2) & Target assembly into the Upper Body (1) making sure both alignment ears on bronze Leading Boogie (7) straddle the guides cast on the inside of the Upper Body. See Fig. 2.
- 6.4 Reinstall 2 T-Head Bolts (3) in Cap and secure with 2 Nuts (4).
- 6.5 Check to assure that the OPEN Target Plate (8) is centered in both sides of the view window.

Visit our website for the most current information.

## 7. Operation

- 7.1 The post indicator valve (PIV) can be opened or shut by rotating Handwheel (15) in the desired direction. To open the valve, turn in the counter-clockwise direction as indicated on Cap (2). To shut the valve, turn in the clockwise direction. See Fig. 2.
- 7.2 The Target Plates (8) (9) can be visually checked in the view windows to determine if PIV is open or shut.
- 7.3 After installation, the PIV should be cycled to the full shut position and both view windows should be visually inspected to assure the SHUT target plates are centered. The PIV should then be cycled to the full open position and both view windows should be visually inspected to assure the OPEN target plates are centered.
- 7.4 Valve position can be secured by placing a customer supplied chain through U-bolt (23), and Handwheel (15). A customer supplied lock can be installed into the chain and U-bolt securing Handwheel, preventing valve operation.
- 7.5 NIBCO Indicator Posts have provisions to add a Security Wire thru the Cap T-bolts (3) and Operating Stem (5) to prevent valve operation.

## 8. Maintenance

- 8.1 Lubrication should be added to oil hole located in top of Operating Stem (5) on an annual basis. Note: it is necessary to remove Eyebolt (16), Washer (17), and Handwheel (15) to expose the oil hole.
- 8.2 Periodic visual inspection is recommended.
- 8.3 Exercising (cycling) of the valve to assure proper function is recommended.

## 9. Repair Parts

- 9.1 Some specialty components are available for replacement if needed. See Table 5.
- 9.2 Common fasteners such as nuts, bolts, and washers are available at your local hardware.

**Table 5**

### REPAIR PARTS WALL MOUNT STYLE

NO.	DESCRIPTION	PART NO.
3	T-HEAD BOLT	NP1AU10
12	VIEW WINDOW	NP1AU06
13	WINDOW GASKET	NP1AU09
14	WINDOW GUARD	NP1AU07
15	HANDWHEEL	NP2AW31

NO.	DESCRIPTION	PART NO.
24	COTTER PIN	NP1AU21
25	OPERATING ROD COUPLING	NP1AU22
26	OPERATING ROD 36"	NP2AW16
26	OPERATING ROD 72"	NP1AU16
26	OPERATING ROD 90"	NP1AU16E

# TS-2M Replacement Instructions

CSA Approved • SEV Approved • UL Listed • FM Approved

## Factory Installed Supervisory Switches For Figure No. 505 Ball Valve



### Supervisory / tamper switch voltage and current ratings:

**Supervisory Switch** - for valve position supervisory / tamper indication used with U.L. listed fire alarm control panel - two (2) leads per terminal; 6 amps @ 125 volts AC 60 Hz, or 1 amp @ 28 volts DC non-inductive. **See Note 2.**

**Auxiliary Switch** - auxiliary switch which may be connected per authority having jurisdiction of auxiliary devices - one (1) lead per terminal; 6 amps @ 125 volts AC 60 Hz, or 1 amp @ 28 volts DC non-inductive.

### NOTES:

- 1) Circuit shown in set condition when valve is in non-open position.
- 2) For connection to system meeting current N.F.P.A requirements, leads A," B," "C," and "D" are used. Connections "E," "F," and "G" are for proprietary use only - **NOT intended for electrical supervision.** Please consult local authority for acceptable connection.
- 3) Refer to N.F.P.A. 13 (Installation of Sprinkler Systems), 70 (National Electrical Code), 72 (Installation, Maintenance, and Use of Protective Signaling Systems), and any other applicable standards prior to installation.
- 4) Supervisory switch is preset and tested in accordance with all applicable agency requirements at the factory. No adjustment is possible once the valve is assembled.
- 5) All lead wires are 18 AWG, 18 inches long and exit the actuator housing through a single threaded hole designed for 1/2-inch conduit fittings.

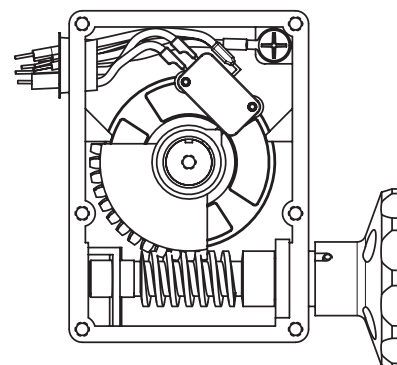
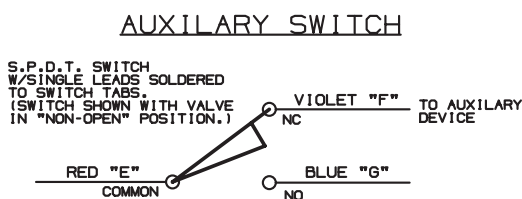
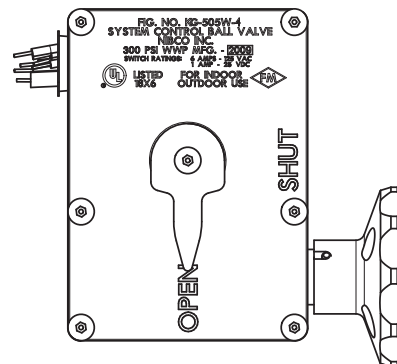
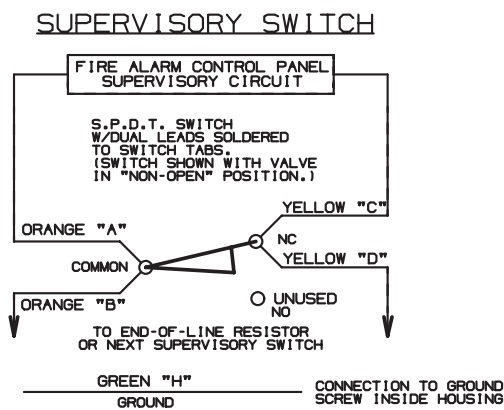

Visit our website for the most current information.

# TS4 Replacement Instructions

CSA Approved • UL Listed • FM Approved



## Factory Installed Supervisory Switches For Figure No. GD-4765-8N/GD-6765-8N Grooved Butterfly Valves and WD/LD-3510-8, 2002 and later Wafer/Lug Butterfly Valves

### Tools required:

- 1/8" Allen wrench
- 5/32" Socket Pin Head Wrench (2" - 8")
- 3/16" Socket Pin Head Wrench (10" - 12")
- 9/16" Socket Wrench (2" - 8")
- 3/4" Socket Wrench (10" - 12")
- 3/16" Standard Screwdriver

1. Remove flag (A) by backing out (approximately 2 turns) hex socket set screw (B).
2. Remove one socket pin head screw (C), three socket head bolts (D) and gear operator cover (E).
3. Remove two screws holding switch assembly into housing, and one screw holding ground wire to housing and remove switch assembly.
4. Feed electrical wires of new switch assembly through hole in rear of housing. Put new switch assembly (F) into gear case with actuating arms against quadrant gear. Reinstall hold down screws and ground wire to housing.
- Before installing cover plate, a continuity test should be performed to assure that switches are properly set.
5. Reinstall cover plate. (D)
6. Reinstall flag. (A)
7. Use and connection of auxiliary switch to be reviewed and accepted by local authority having jurisdiction.

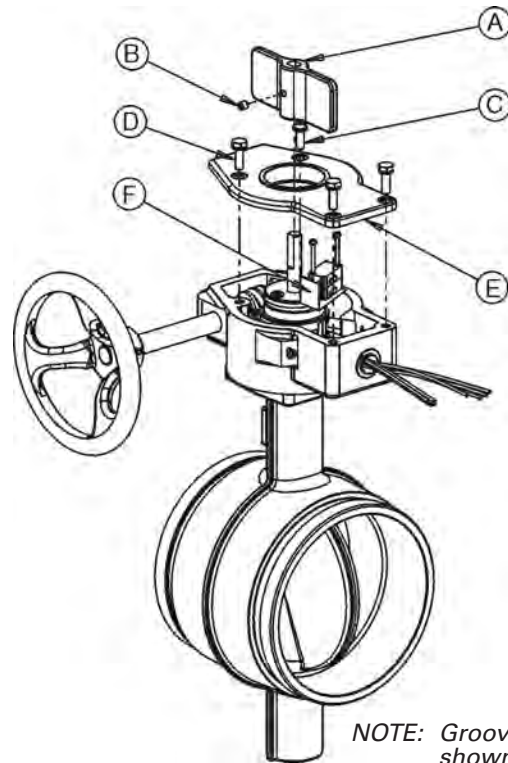

**NOTE:** Grooved end valve shown for illustration purposes only.

**\*Instructions are same regardless of valve end connections.**

**Note:** Reference Section VI of the Rubber-Seated Butterfly Valve O&M Manual.

## TS4 Replacement Instructions cont.

### TS-4 Switch Specifications:

1 - S.P.S.T. / 1 - S.P.D.T.

Rating: 11 amps @ 125 VAC 60 Hz or  
1 amp @ 28 VDC non-inductive.

Wiring: All lead wires are 18 AWG, 18 inches long and exit actuator housing through a single hole designed for 1/2" conduit fittings.

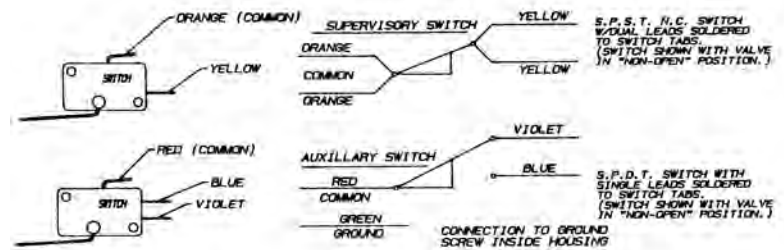

VALVE SERIES	SUPERVISION POSITION	SWITCH KIT NUMBER
GD4765-8N WD/LD3510-8*	Valve Open	T117774 PP (TS-4)
GD4765C-8N WD/LD3510C-8*	Valve Closed	T118542 PP
GD4865-8N GD6865-8N	Valve Open	T1446762 PP
GD4865C-8N GD6865C-8N	Valve Closed	T1447532 PP

**\*2002 or Newer Model Wafer & Lug UL/FM Butterfly Valves**

**NOTE: Reference Section VI of the Rubber-Seated Butterfly Valve O&M Manual.**

Visit our website for the most current information.

# Properties of Valve Materials

ALLOY	ASTM NO.	OTHER ALLOY DESIGNATION	NOMINAL OR MAXIMUM CHEMICAL COMPOSITION								
			CARBON		CHROME	COBALT	COPPER	IRON	LEAD	MANGA-NESE	MOLYB-DENUM
			AL	C	Cr	Co	Cu	Fe	Pb	Mn	Mo
Commercial Aluminum 380	SC 84 A	UNS A38000	87.0				1.0	1.3			.35
Free Cutting Brass	B16	UNS C36000					61.5				3.0
(Steam Bronze)	B61	UNS C92200					88.0	.25			1.5
(Ounce Metal)	B62	UNS C83600					85.0	.30			5.0
Copper-Silicon Alloy B	B98/B99	UNS C65100					96.0	.8	.05		.7
Forging Brass	B124	UNS C37700					60.0	.3			2.0
Forging Brass	B283	UNS C37700					58.0	.3	2.5		
Brass Wire (Red Brass)	B134	UNS C23000					85.0	.05			.05
Leaded Red Brass	B140	UNS C31400					89.0	.10			1.9
(Cast)	B148	UNS C95400					85.0				4.0
Aluminum Bronze (Rod)	B150	UNS C64200	7.0				91.0	.30	.05		.10
Silicon Red Brass	B371	UNS C69400					81.5	.20	.30		
Brass	B584	UNS C84400					81.0	.40			7.0
Leaded Red Brass		UNS C84500	.005				78.0	.40			7.0
Leaded Nickel Bronze	B584	UNS C97600					64.0				4.0
(Wrot)	B 75	UNS C12200									99.9
Gray Iron	A126										Class B
3% Ni Gray Iron	A126										Class B
(Ni-Resist)	A436	Type 2									1.0
Ductile Iron (Ferritic)	A395										3.20
Austenitic Ductile Iron (Ductile)	A536 65-45-12										
(Ductile)	A536 80-55-06										
(Ni-Resist)	A439 D2C		2.9		.5					2.4	1.0

Visit our website for the most current information.

NOMINAL OR MAXIMUM CHEMICAL COMPOSITION								NOMINAL PHYSICAL PROPERTIES				
NICKEL Ni	PHOS P	SILICON Si	SULFUR S	TIN Sn	TITAN- IUM Ti	TUNG- STEN W	ZINC Zn	TENSILE STRENGTH Psi	STRENGTH Psi	YIELD ELONGATION	% HARDNESS	
.50		12.0		.15			.50	42,000	19,000		3.5	
							35.5	50,000	20,000	15	75 HRB	
1.0	.05	.005	.05	6.0			4.5	34,000	16,000	22	65 HB *500 kg	
1.0	.05	.005	.08	5.0			5.0	30,000	14,000	20	60 HB 500 kg	
		1.6					1.5	86,000**	20,000	11	65 HRB	
							38.0	52,000	20,000	45	80 HRB	
							38.0	52,000	20,000	45	78 HRB	
							15.0	56,000			60 HRB	
.7							9.1	50,000	30,000	7	60 HRB	
								75,000	30,000	12	170 HB *3000 kg	
.25		2.0		.20			.50	90,000	45,000	9	80 HRB	
		4.0					14.5	80,000	40,000	15	85 HRB	
	.02	.005	.08	3.0			9.0	29,000	13,000	18	55 HB *500 kg	
1.0	.02	.005	.08	3.0			12.0	29,000	13,000	16	55 HB *500 kg	
20.0				4.0			8.0	40,000	17,000	10	80 HB	
	.02							36,000	30,000	25	45 T	
	.75		.15					31,000			195 HB	
3.00	.75		.15					31,000			195 HB	
20.0		2.0	.12					25,000			118 HB	
	.08	2.50						60,000	40,000	18	167 HB	
	.08	2.50						65,000	45,000	12	160 HB	
	.08	2.50						80,000	55,000	6	160 HB	
24.0	.08	3.0						58,000	28,000	20	146 HB	

\*Load Applied During Testing  
 \*\*Allowable Range is 75,000 to 95,000

Visit our website for the most current information.

# Flow Data

## Cv Values for Valves

**Liquid Flow:**

$$Q = C_v \sqrt{\frac{\Delta P}{S}} \quad \text{or} \quad \Delta P = S \left( \frac{Q}{C_v} \right)^2$$

where . . . Q = flow rate (gallons per minute)  
 ΔP = pressure drop across valve (psi)  
 S = specific gravity of media

This equation is good for turbulent flow and for liquids with viscosities near that of water.  
 (Cv is defined as the flow in GPM that a valve will carry with a pressure drop of 1.0 PSI when the media is water at 60° F.)  
 (The specific gravity of water is 1 (one). )

**WARNING**

The Fluid Flow factors contained herein are calculated values. They are, therefore, approximations and cannot be used for highly critical flow or pressure drop calculations. For very precise flow measurements, tests must be conducted on any valve mentioned within this catalog. Throttling of Ball Valves is not recommended when valves are less than 45° open.

### VALVE SIZE

Fig. Nos.	¼	½	¾	1	1¼	1½	2	2½	3	4	5	6	8	10	12
<b>GATES</b>															
T-103-HC/104-0	5.6	17.6	32	54	97	135	230	337							
F-607-609-637 -667-697															
M-609							215	335	510	945	1,525	2,250	4,150	6,700	9,925
<b>GLOBES</b>															
KT-211-WUL/ KT-65-UL	1.16	3.64	6.65	11.1	20	28	48	70	111						
<b>CHECKS</b>															
KT-403-W(SWING)	2.5	4.8	14.3	24	43	60	102	150	238						
T-480(POPPET)	3.70	6.86	16.3	30	49	72	130								
F938/F968 (SWING F908)							137	221	327	605	975	1,440	2,670	—	—
KG-900-W/350 G920W (GROOVED)							76	161	224	400	648	1,060	1,890	3,340	5,270
KW-900-W (WAFER)/ W920W (WAFER)							60	105	184	354	577	801	1,500	2,357	3,742
<b>BALL</b>															
KT-505W	—	—	—	57	103	143	245	183							
KG-505W	—	—	—	—	—	143	245	183							
T-580-70	—	—	—	—	44	76.1	101.4	183	390						
T-585-70	5.6	18.7	34	57	103	143	245	310							
KT-580-70UL	—	—	—	—	44	76.1	101.4	—							
KT-585-70UL	5.6	18.7	34	57	—	—	—	—							
<b>BUTTERFLY</b>															
WD/LD-3510							166	247	340	660	1,080	1,613	3,759	5,300	7,969
GD-4765/6765							145	195	290	600	—	1,600	3,450	5,800	—
GD-4865/6865							158	235	323	627	1,026	1,532	3,571	5,035	—
GD-1765							—	—	—	—	—	—	—	5,800	—

**NOTE: Angle Globe Valves (KT67, T301W) flow is 1.25 x straight (KT65, KT211) configuration.**

Visit our website for the most current information.

# Gate Valve Dimensions for Supervisory Switch Application

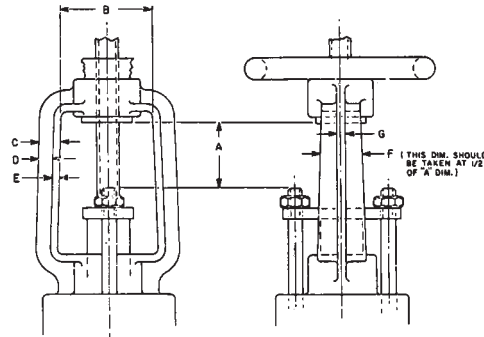

Valve	Size	A	B	C	D	E	F	G	Pitch	Stem Dia. and Thds/in	Lead	Thread Type
<b>T-104-O</b>	½	0.33	1.50	0.28	—	—	0.63	—	.08	0.44-12.00	Dble.	60° STUB
	¾	0.33	1.50	0.31	—	—	0.63	—	.08	0.44-12.00	Dble.	60° STUB
	1	0.70	1.63	0.31	—	—	0.75	—	.08	0.50-12.00	Dble.	60° STUB
	1¼	0.35	2.63	0.31	—	—	0.81	—	.11	0.56-9.00	Dble.	60° STUB
	1½	0.35	2.63	0.31	—	—	0.88	—	.11	0.56-9.00	Dble.	60° STUB
	2	0.84	2.50	0.44	—	—	0.88	—	.13	0.69-8.00	Dble.	60° STUB
<b>F-607-OTS</b>	2½	1.13	2.38	0.88	0.44	0.44	1.19	0.38	.17	0.75-6.00	Dble.	STUB ACME
	3	1.75	2.50	0.88	0.50	0.38	1.63	0.38	.17	0.75-6.00	Dble.	STUB ACME
	4	1.63	3.13	1.50	0.75	0.75	2.00	0.50	.25	1.00-4.00	Dble.	STUB ACME
	5	2.50	3.38	1.50	0.75	0.75	2.25	0.75	.25	1.00-4.00	Dble.	STUB ACME
	6	2.50	3.38	1.50	0.75	0.75	2.25	0.75	.25	1.13-4.00	Dble.	STUB ACME
	8	4.75	4.50	1.63	0.75	0.88	2.03	0.75	.25	1.25-4.00	Dble.	STUB ACME
	10	6.63	4.50	2.25	1.25	1.00	3.00	0.75	.33	1.38-3.00	Sggle.	STUB ACME
12	6.63	4.50	2.25	1.00	1.00	3.00	0.75	.33	1.50-3.00	Sggle..	STUB ACME	
<b>F-667-O/F-697-O</b>	2½	1.13	2.25	0.50	—	—	2.00	—	.17	0.75-6.00	Dble.	STUB ACME
	3	1.56	2.75	1.00	0.50	0.50	2.25	0.50	.25	1.00-4.00	Dble.	STUB ACME
	4	1.63	3.75	1.50	0.75	0.75	2.00	0.50	.25	1.13-4.00	Dble.	STUB ACME
	5	1.25	4.50	1.63	0.75	0.88	3.00	0.75	.25	1.25-4.00	Dble.	STUB ACME
	6	1.25	4.38	1.63	0.75	0.88	2.88	0.75	.33	1.38-3.00	Dble.	STUB ACME
	8	7.63	4.50	2.44	1.38	1.63	4.75	0.75	.33	1.50-3.00	Dble.	STUB ACME
	10	8.25	4.50	2.50	1.75	0.75	4.75	0.75	.50	1.88-2.00	Sggle.	STUB ACME
12	8.88	4.50	2.50	1.75	0.75	4.00	0.75	.50	1.88-2.00	Sggle.	STUB ACME	
<b>F-607-RW</b>	2½	1.55	2.56	0.76	0.45	0.31	1.43	0.31	.16	0.79 X 6.25	Sggle.	ACME
	3	2.04	2.56	0.75	0.43	0.31	1.42	0.31	.16	0.79 X 6.25	Sggle.	ACME
	4	2.55	2.95	0.79	0.39	0.39	1.67	0.39	.20	0.98 X 5.00	Sggle.	ACME
	6	4.04	3.54	0.81	0.38	0.43	1.73	0.43	.20	1.70 X 5.00	Sggle.	ACME
	8	6.04	3.98	0.92	0.45	0.47	2.11	0.47	.24	1.26 X 4.20	Sggle.	ACME
	10	7.84	4.33	0.99	0.44	0.55	2.52	0.55	.24	1.42 X 4.20	Sggle.	ACME
12	9.84	4.33	0.94	0.39	0.55	2.48	0.55	.24	1.57 X 3.60	Sggle.	ACME	

Note: All valves have left hand thread.

Visit our website for the most current information.

# Grooved Pipe Specification

Conforms to ANSI/AWWA C-606

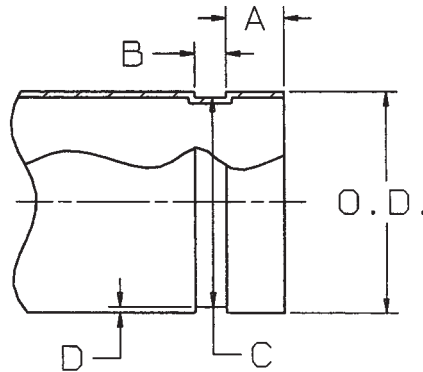

1 Nominal Size Inches	2 Pipe Outside Diameter O.D.		3 Gasket Seal A +/-0.03	4 Groove Width B +/-0.03		5 Groove Diameter		6 Groove Depth (Ref.) D	7 Min. Allowable Wall Thickness		8 Maximum Allow Flare Diameter Roll Groove
	Actual O.D.	Tolerance		Roll Groove	Cut Groove	Actual	Tolerance +0.000		Roll Groove TR	Cut Groove TR	
1 1/4	1.600	+0.016 -0.016	0.625	0.281	0.313	1.535	-0.015	0.063	0.065	0.140	1.77
1 1/2	1.900	+0.019 -0.019	0.625	0.281	0.313	1.775	-0.015	0.063	0.065	0.145	2.01
2	2.375	+0.024 -0.024	0.625	0.344	0.313	2.250	-0.015	0.063	0.065	0.154	2.48
2 1/2	2.875	+0.029 -0.029	0.625	0.344	0.313	2.720	-0.018	0.078	0.083	0.188	2.98
3	3.500	+0.035 -0.031	0.625	0.344	0.313	3.344	-0.018	0.078	0.083	0.188	3.60
4	4.500	+0.045 -0.031	0.625	0.344	0.375	4.344	-0.020	0.083	0.083	0.203	4.60
5	5.563	+0.056 -0.031	0.625	0.344	0.375	5.395	-0.022	0.084	0.109	0.203	5.66
6	6.625	+0.063 -0.031	0.625	0.344	0.375	6.455	-0.022	0.085	0.109	0.219	6.73
8	8.625	+0.063 -0.031	0.750	0.469	0.438	8.441	-0.025	0.092	0.019	0.238	8.80
10	10.750	+0.063 -0.031	0.750	0.469	0.500	10.562	-0.027	0.094	0.134	0.250	10.92
12	12.750	+0.063 -0.031	0.750	0.469	0.500	12.531	-0.030	0.109	0.156	0.279	12.92

**COLUMN 1:**

-Normal IPS pipe size outside diameter.

**COLUMN 2:**

-Maximum Deviation from square-cut ends for 1.25" thru 3" is 0.03"; for 4" thru 6" is 0.045" and for 8" and above is 0.06".

**COLUMN 3:**

-To provide a leak-tight seal, the gasket seating area pipe shall be free from roll marks, indentations, paint scale, dirt, chips, grease and rust, etc.

**COLUMN 4:**

-Groove Width: Groove bottom to be free from loose dirt, chips, rust and scales. Bottom and grooves to be radiused and the vertical wall of grooves must provide at least 0.03" vertical side for proper assembly and coupling.

**COLUMN 5:**

-Groove Outside Diameter: The groove must be concentric to the pipe circumference. Groove must be within the diameter tolerance indicated.

**COLUMN 6:**

-Groove Depth: For reference only. (Refer to Column 5)

**COLUMN 7:**

-Minimum allowable wall thickness to which the pipe may be roll grooved or cut grooved.

**COLUMN 8:**

-Maximum allowable pipe end flare diameter. Measured at the most extreme pipe ends.

Visit our website for the most current information.

## Figure Number Comparisons

### GATE, GLOBE, CHECK AND INDICATOR POST

NIBCO	KENNEDY	MUELLER	UNITED	CLOW	VICTAULIC
T-103-HC	39NS	—	—	—	—
T-104-0	66	—	18	—	—
KT-65-UL, KT-211-UL	97SD*	—	1255UL	—	—
KT-291-W3*	220*	—	76*	—	—
KT-67-UL, T-301-W	98SD	—	1265UL	—	—
T-331-HC	936	—	—	—	—
KT-403-W*	440SD*	—	995*	—	—
F-607-OTS	68	A2073-6	—	F5733	—
F-607-RW	8068A (C509)	R-2361-6	—	F6136	—
	7068A (C515)				
F-609	701	A2052-6	—	F5722	—
F-609-RW	8701ASS (C509)	P2361-6	—	F6102	—
	7701SS (C515)				
M-609	71	A2052-20	—	F5725	—
M-609-RW	8071SS (C509)	P2361-16	—	F6100	—
	7071SS (C515)				
F-697-0	3068	—	—	—	—
F-908W	126A	A2122-6	—	F5347R	—
KW-900-W	706	A2102	90	—	—
NIP-1AU	2945A	A20806	—	2945A	773
NIP-2AW	641-13	A20813	—	F5761	774

\*Not UL Listed

### BALL & BUTTERFLY

NIBCO	MILWAUKEE	VICTAULIC	STOCKHAM	UNITED	KENNEDY
T-585-70*†	—	—	T285	—	775*†
KT-505W-8	BB-SC502	728	—	—	—
KG-505W-8	BB-SC100				
WD3510-8	—	—	—	—	W300
LD3510-8	—	—	—	—	93WI
GD-4865-8N	—	705	—	—	G300
KT-580/585-70UL	—	722	—	—	—

\*Not UL Listed

†Not FM Approved

Visit our website for the most current information.

# A Typical Fire Protection Sprinkler System

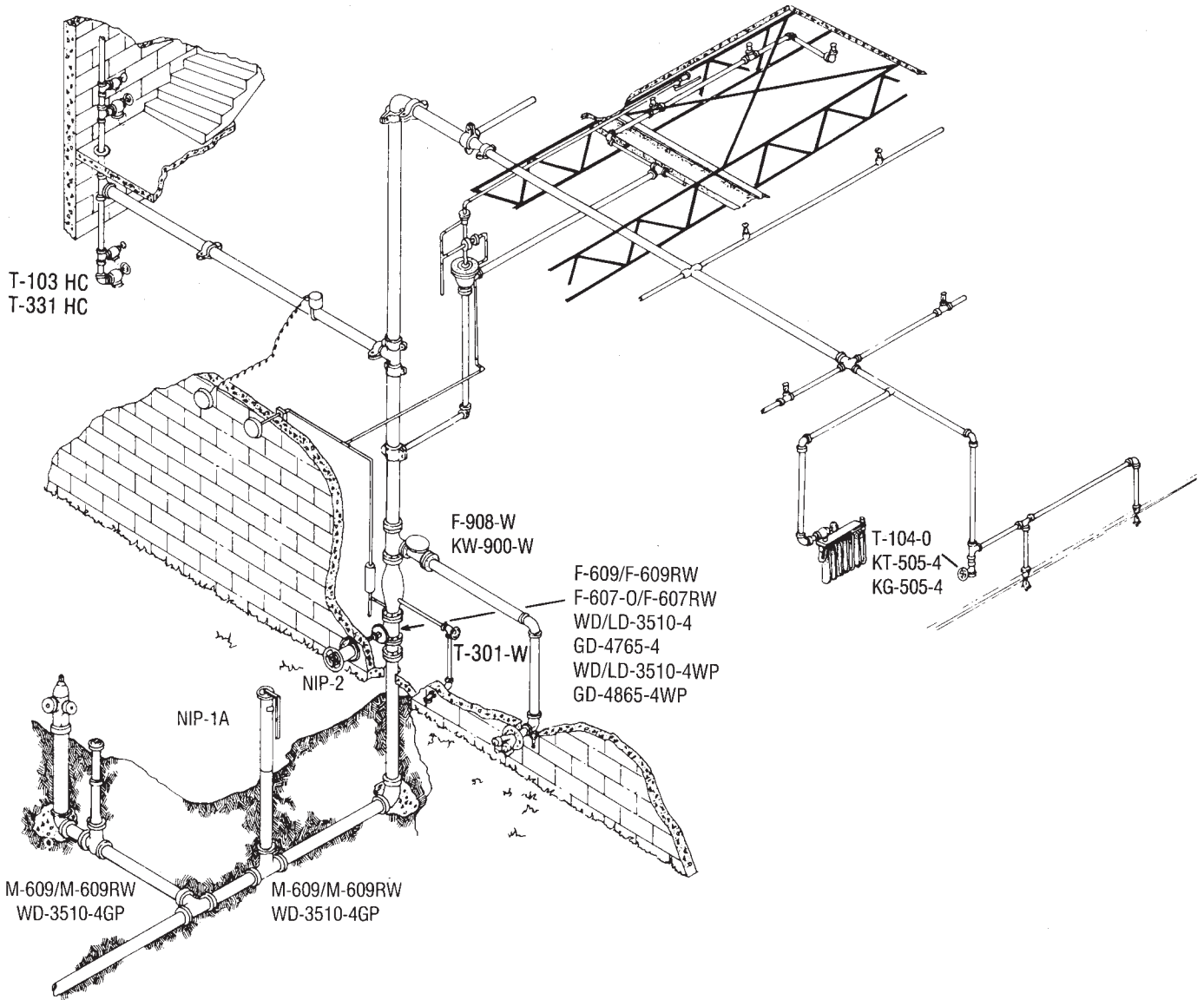

*Schematic courtesy of Rick Perella*

Visit our website for the most current information.

## REPLACEMENT HANDWHEELS F607RW & F607RWS GATE VALVES

VALVE SIZE	F607RWS	F607RW
2½"	T1447559 PP	T117454 PP
3"		
4"	T1447560 PP	T117422 PP
6"	T1447561 PP	T117427 PP
8"	T1447562 PP	T117400 PP
10"	T117485 PP	
12"	T117371 PP	

## REPLACEMENT HANDWHEEL NUTS F607RW & F607RWS GATE VALVES

VALVE SIZE	F607RWS			F607RW		
	MATERIAL NO	NUT OD X TK	THREAD SIZE	MATERIAL NO	NUT OD X TK	THREAD SIZE
2½"	T1470614 PP	52 X 10	M30 X 1.5	T1098244 PP	52 X 10	M33 X 1.5
3"						
4"	T1470615 PP	58 x 10	M39 X 1.5	USE T1470616 PP	68 X 10	M45 X 1.5
6"						
8"	T1470616 PP	68 x 10	M45 x 1.5	T1470616 PP	72 X 12	M48 X 1.5
10"	T1471723 PP	72 x 12	M48 x 1.5			
12"	T1470617 PP	78 X 12	M52 X 1.5	T1470617 PP	78 X 12	M52 X 1.5
14"	T1470618 PP	90 X 12	M60 X 2			
16"						

Visit our website for the most current information.

# Fire Protection Butterfly Valves

## Gear Operator Repair Parts

ITEM	VALVE SIZE	VALVE ASSEMBLY FIGURE NUMBER	BUSHING REFERENCE NUMBER	BUSHING ASSEMBLY PART NUMBER	DRIVE KEY PART NUMBER	DRIVE KEY SIZE	DRIVE KEY MATERIAL	FLAG PART NUMBER (YELLOW)	HAND-WHEEL PART NUMBER	HAND-WHEEL PIN PART NUMBER
1	2"	WD/LD 3510	01	T117725 PP	T117850 PP	1/8" SQ X .38" LG	BRASS	T117865 PP	T117122 PP	T117877 PP
2	2½" & 3"	WD/LD 3510	02	T117726 PP	T117851 PP	1/8" SQ X .68" LG	BRASS	T117865 PP	T117122 PP	T117877 PP
3	2½" & 3"	GD-4765/6765	02	T117726 PP	T117850 PP	1/8" SQ X .38" LG	BRASS	T117865 PP	T117122 PP	T117877 PP
4	2½" & 3"	GD-4865/6885	-	T118778 PP	T117852 PP	1/8" SQ X .44" LG	STEEL	T1446767 PP	T1446759 PP	INCLUDED
5	4"	WD/LD 3510	03	T117727 PP	T117852 PP	1/8" SQ X .44" LG	STEEL	T117865 PP	T117122 PP	T117877 PP
6	4"	GD-4865/6885	-	T118779 PP	T117852 PP	1/8" SQ X .44" LG	STEEL	T1446767 PP	T1446759 PP	INCLUDED
7	4" & 5"	GD-4765/6765	04	T117728 PP	T117853 PP	1/8" SQ X .29" LG	STEEL	T117865 PP	T117122 PP	T117877 PP
8	5" & 6"	WD/LD 3510	04	T117728 PP	T117854 PP	1/8" SQ X .41" LG	STEEL	T117865 PP	T117122 PP	T117877 PP
9	6"	GD-4765/6765	05	T117729 PP	T117856 PP	1/8" SQ X .91" LG	STEEL	T117865 PP	T117122 PP	T117877 PP
10	6" & 8"	GD-4865/6885	-	T118780 PP	T117856 PP	1/8" SQ X .91" LG	STEEL	T1446767 PP	T1446760 PP	INCLUDED
11	8"	WD/LD 3510	05	T117729 PP	T117856 PP	1/8" SQ X .91" LG	STEEL	T117865 PP	T117123 PP	T117877 PP
12	8"	GD-4765/6765	05	T117729 PP	T117856 PP	1/8" SQ X .91" LG	STEEL	T117865 PP	T117123 PP	T117877 PP
13	10"	WD/LD 3510	06	T117730 PP	T117858 PP	3/16" SQ X 1.00 LG	STEEL	T117865 PP	T118472 PP	T117877 PP
14	10"	GD-1765/6765	07	T117731 PP	T117858 PP	3/16" SQ X 1.00 LG	STEEL	T117865 PP	T118472 PP	T117877 PP
15	10"	GD-4865/6885	-	T118781 PP	T117858 PP	3/16" SQ X 1.00 LG	STEEL	T1446767 PP	T1446760 PP	INCLUDED
16	12"	WD/LD 3510	07	T117731 PP	T117858 PP	3/16" SQ X 1.00 LG	STEEL	T117865 PP	T118472 PP	T117877 PP

- Notes: 1. T117865 PP flag is painted yellow. For red painted flag use part number T1414066 PP.  
 2. T1446767 PP flag is painted yellow. For red painted flag use part number T1446768 PP.  
 3. Thread cutting screw T1430191 PP is included with T1446767 PP & T1446768 flags.  
 4. Handwheel pin is included with T1446759 PP & T1446760 PP handwheels.

## Supervisory Switches

ITEM	VALVE ASSEMBLY SERIES FIGURE NUMBER	SUPERVISION POSITION	SWITCH KIT PART NUMBER	
17	WL/LD3510-8* & GD4765-8N	VALVE OPEN	T117774 PP (TS-4)	* 2002 OR NEWER MODEL WAFER & LUG UL/FM BUTTERFLY VALVES
18	WL/LD3510C-8* & GD4765C-8N	VALVE CLOSED	T118542 PP	
19	GD4865-8N & GD6865-8N	VALVE OPEN	T1446762 PP	
20	GD4865C-8N & GD6865C-8N	VALVE CLOSED	T1447532 PP	
21	WL/LD3510-8* & GD4765-8N	VALVE OPEN	T118855 ASBLY	FOR HARSH ENVIRONMENT SERVICE

Visit our website for the most current information.

## Notes:

*Visit our website for the most current information.*

## Notes:

*Visit our website for the most current information.*

## Notes:

*Visit our website for the most current information.*

# NIBCO® Pressure Rated Metal Valves Limited Warranty



## NIBCO INC. 125% LIMITED WARRANTY

Applicable to NIBCO Pressure Rated Metal Valves

NIBCO INC. warrants each NIBCO pressure rated metal valve ("Valves") to be free from defects in materials and workmanship under normal use, service, and maintenance in accordance with the product specifications (including, but not limited to installation recommendations) for a period of five (5) years from the Warranty Commencement Date. The Warranty Commencement Date shall be the date upon which a Valve is installed.

NIBCO will repair or replace – at its option and at no charge – Valves that have been determined by NIBCO, or an authorized representative or agent thereof, to have failed solely because of a defect in materials or workmanship under normal use, service, and maintenance during the warranty period. Replacements shall be shipped free of charge to the owner. In the event of the replacement of any Valve, NIBCO shall further pay the owner the greater of twenty-five (25%) percent of the price of the Valve according to the published suggested list price schedule of NIBCO in effect at the time of purchase, or ten (\$10.00) dollars, to apply on the cost of the installation of said replacement Valve.

This limited warranty applies to all Valves installed, tested, applied, and used in accordance with NIBCO's approved and published recommendations and instructions.

This warranty does not cover any failure or damage for or caused by:

1. any product, parts, or systems which are not manufactured or sold by NIBCO;
2. any Valve which is used for purposes other than a purpose authorized by NIBCO;
3. any Valve not installed, tested, applied, used, or maintained in accordance with NIBCO's recommended installation guidelines and instructions;
4. any Valve not installed or used in accordance with applicable codes;
5. any damage caused by, contributed in whole or in part by, or resulting from, any of the following:
  - a. abuse, misuse, mishandling, alteration, tampering, neglect, or accidental damage such as, without limitation, vandalism;
  - b. natural disasters, such as, without limitation, flooding, windstorm, and lightning;
  - c. attachments or modifications not authorized by NIBCO;
  - d. external, physical or chemical qualities, or an unsuitable or hostile environment,;
  - e. any defects other than those in material or workmanship; or
  - f. any other cause beyond the control of NIBCO.

NIBCO DISCLAIMS ANY AND ALL LIABILITY FOR ANY OTHER DIRECT OR INDIRECT, INCIDENTAL, OR CONSEQUENTIAL DAMAGES OF ANY KIND, INCLUDING BUT NOT LIMITED TO, ECONOMIC LOSS, LOSS OF BUSINESS, LOST PROFITS, PUNITIVE DAMAGES, MOLD INTRUSION, WATER DAMAGE, ETC.

Some states do not allow the exclusion or limitation of damages, so the above limitation or exclusion may not apply to you.

THIS WARRANTY IS THE ONLY WARRANTY FOR THE VALVES PROVIDED BY NIBCO, AND IS AND SHALL BE IN LIEU OF ANY AND ALL OTHER WARRANTIES, EXPRESSED OR IMPLIED, INCLUDING, BUT NOT LIMITED TO, AN IMPLIED WARRANTY OF MERCHANTABILITY OR FITNESS FOR A PARTICULAR PURPOSE, AND FOR ALL OTHER OBLIGATIONS OR LIABILITIES ON THE PART OF A MANUFACTURER. NO EMPLOYEE OF NIBCO, OR ANY OTHER DISTRIBUTOR, AGENT, OR OTHER PERSON OR BUSINESS, IS AUTHORIZED TO MAKE ANY OTHER WARRANTY ON BEHALF OF NIBCO.

Some states do not allow limitations on implied warranties, so the above limitation may not apply to you.

In the event any defect occurs which is believed to be covered by this warranty, NIBCO Technical Services must immediately be contacted by calling 888.446.4226 or emailing CS-TechnicalServices@nibco.com. NIBCO Technical Services after being contacted will make further arrangements for the product's return to NIBCO at the customer's expense for review and evaluation.

This warranty gives you specific legal rights, and you may also have other rights which vary from state to state.



Visit our website for the most current information.



# NIBCO®

## Global Locations

### MANUFACTURING PLANTS

#### **Metal Fittings & Valves**

Blytheville, Arkansas

McAllen, Texas

Nacogdoches, Texas

Stuarts Draft, Virginia

Worcester, Massachusetts

#### **Plastic Pipe, Valves, & Fittings**

Goshen, Indiana

Greensboro, Georgia

#### **International**

Lodz, Poland

Reynosa, Mexico



### INTERNATIONAL OFFICES

#### **World Headquarters**

Elkhart, Indiana

#### **European Office**

Lodz, Poland



VISIT OUR WEBSITE TO LEARN MORE



Press Webstone PressACR Bench  
system Chemtrol NIBCO  
SURE SEAL FLO-BOSS Press  
NIBCO wrot racer FAST PUSH FITTINGS Bench PressG  
Bench Press Webstone PressACR  
presssystem NIBCO Chem  
PressG SURE SEAL FLO-BOSS  
G NIBCO wrot racer FAST PUSH FITTINGS Bench Press  
Press Webstone PressACR Bench  
system Chemtrol NIBCO pr  
SURE SEAL FLO-BOSS Press  
NIBCO wrot racer FAST PUSH FITTINGS Bench PressG  
Bench Press Webstone Press  
NIBCO presssystem Chemtro  
OSS PressG SURE SEAL FLO  
essACR Bench

# NIBCO®

NIBCO INC.  
WORLD HEADQUARTERS

1516 MIDDLEBURY STREET  
ELKHART, IN 46516-4740 USA  
WEB: [www.nibco.com](http://www.nibco.com)

DOMESTIC CUSTOMER SERVICE  
PHONE: 800.234.0227  
FAX: 800.234.0557

TECHNICAL SERVICE  
PHONE: 888.446.4226  
FAX: 888.336.4226

INTERNATIONAL OFFICE  
PHONE: +1/574.295.3327  
FAX: +1/574.295.3455