

NIBCO®

AHEAD OF THE FLOW®

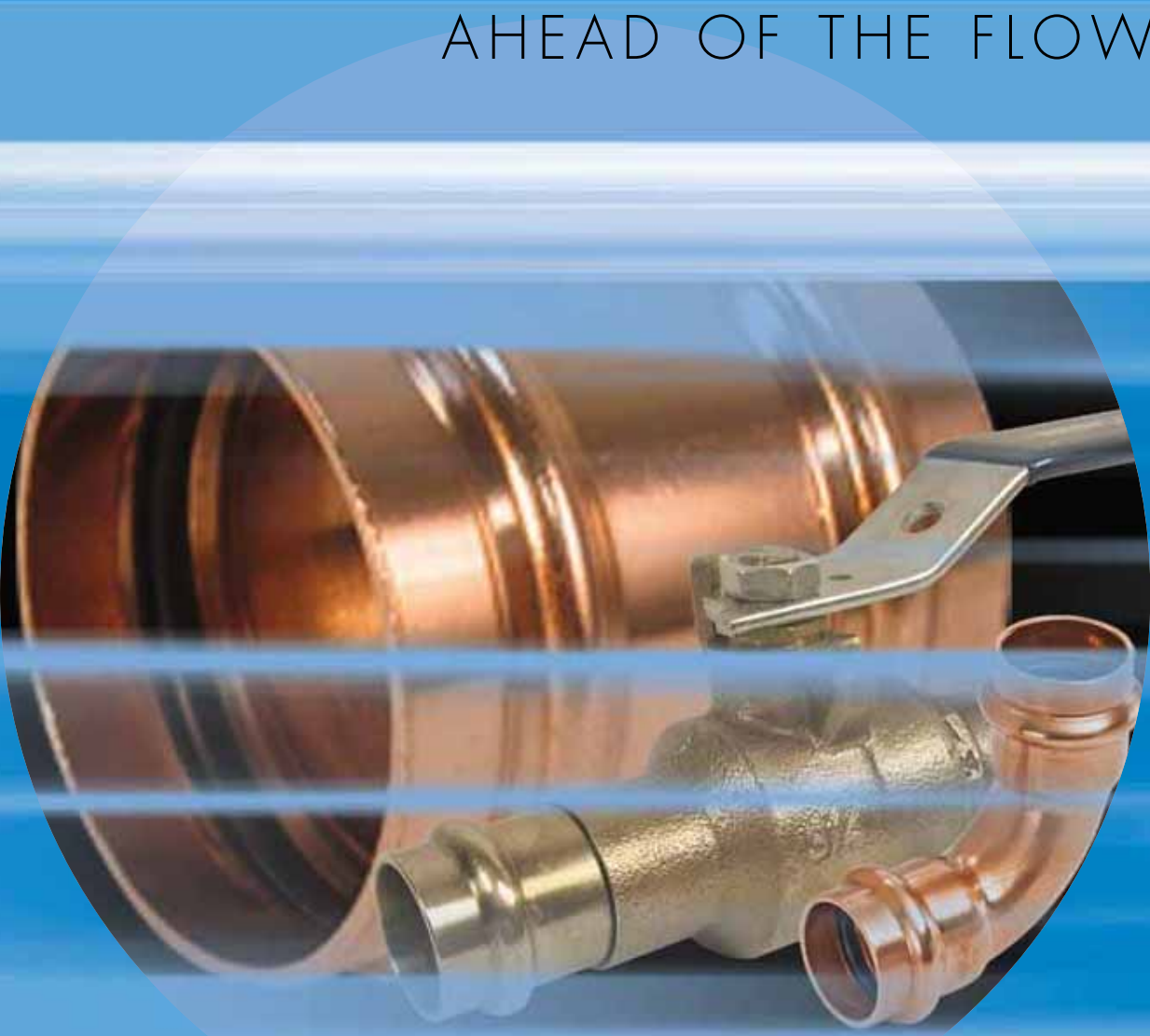

RTC GLOBAL
International Procurement & Trading Company

TO ORDER | +1613 276 8098
| +1613 249 7144
| sales@rtcglobal.ca
| www.rtcglobal.ca

NIBCO® Press System®

Business-to-Business Solutions

Look to NIBCO for technology leadership.

The velocity with which e-business evolves demands that new products and services be continuously developed and introduced to keep our customers at the center of our business efforts. NIBCO provides an entire suite of business-to-business solutions that is changing the way we interact with customers.



RTC GLOBAL
International Procurement & Trading Company

TO ORDER

T +1613 276 8698
F +1613 249 7144
E yazeed@rtcglobal.ca
W www.rtcglobal.ca



Electronic Data Interchange (EDI) makes it possible to trade business documents at the speed of light. This technology cuts the cost of each transaction by eliminating the manual labor and paperwork involved in traditional order taking. This amounts to cost-savings, increased accuracy and better use of resources.

With EDI, you can trade:

- Purchase orders
- PO Acknowledgements
- Invoices
- Product activity data
- Advanced ship notices
- Remittance advice



Vendor Managed Inventory (VMI), a sophisticated service for automated inventory management, reduces your overhead by transferring inventory management, order entry and forecasting to NIBCO. This is an on-going, interactive partnership with NIBCO.

Through automation, VMI brings results:

- Improves customer service
- Optimum inventory efficiencies
- Better forecasting
- Cuts transaction costs
- Peace of mind
- Relief from day-to-day management



NIBCO® Press System®

Table of Contents



Visit our website for the most current information.

Contents		Page			Page
Contents		1			
Fittings		3-9			
Adapters		4	Handle Options and Accessories		35
Caps		4	NIB-SEAL® Technical Data		36
Couplings		4	Butterfly Valve Options and Accessories		37
Elbows		5	Butterfly Valve Technical Information		38
Fitting Reducers		7	Tools and Jaws		39-43
Flanges		7	NIBCO® Standard Pressing Tool - PC-280		40
Manifolds		7	NIBCO® Mini Pressing Tool - PC-20M		41
Tees		8	NIBCO® PC-10M and PC-100 Accessories		42
Unions		9	Approved Tool and Jaw Compatibility Matrix		43
Accessories		9	Engineering Data		44-47
Valves		10-43	Copper and Copper Alloy Fittings		45
Illustrated Index		11-12	Sample Specification - Fittings		46
PC585-70 Ball Valve		13	Sample Specification - Valves		47
PC585-70-66 Ball Valve		14	Installation Instructions		48-64
PC585-70-NS Ball Valve w/ NIB-SEAL® Handle		15	1/2" - 2" Fittings and Valves		49
PC585-70-66-NS Ball Valve w/ NIB-SEAL® Handle		16	2 1/2" - 4" Fitting and Valves		52
PC585-70-LL Ball Valve w/ Locking Lever Handle		17	Testing Instructions for Leak Detection		54
PC585-70-66-LL Ball Valve w/ Locking Lever Handle		18	Miscellaneous Technical Information		55
PC585-70-HC Ball Valve-Hose Connection w/Cap & Chain		19	Frequently Asked Questions		56
PC585-70-66-HC Ball Valve-Hose Connection w/Cap & Chain		20	NIBCO® Press System® Fittings Warranty		57
PC585-80-LF Lead-Free* Ball Valve		21	NIBCO® Pressure Rated Metal Valves Warranty		58
PC585-66-LF Lead-Free* Ball Valve		22			
PFFP600 Ball Valve		23			
PF111 Gate Valve		24			
PF113 Gate Valve		25			
PF211-Y Globe Valve		26			
PF311-Y Angle Valve		27			
PF413-Y Check Valve		28			
PF480-Y In-line Check Valve		29			
PFD2000 Butterfly Valve		30			
PS585-70 Ball Valve		31			
PS585-70-66 Ball Valve		32			
PS585-70-HC Ball Valve-Hose Connection w/Cap & Chain		33			
PF221/222-A/B Bronze Y-Strainer		34			

*Lead Free refers to the wetted surface of pipe, fittings and fixtures in potable water systems that have a weighted average lead content ≤ 0.25% per the Safe Drinking Water Act (Sec. 1417) amended 1-4-2011 and other equivalent state regulations.

NIBCO® pres@system®

EXPERIENCE THE CONNECTION™

Quick and Easy

The NIBCO® Press System® is user friendly, quick and easy to install. Installation can be completed in less time than traditional solder, threaded, brazed or grooved copper systems. Significant time savings means tight budgets and deadlines are met while project delays and cost overruns are avoided.

Full System Product Offering

The NIBCO® Press System® is more than just 1/2" to 4" fittings. Our offering also includes the industry's widest and most specified range of ball, gate, globe, angle, check and butterfly valves in addition to a full line of NIBCO® tools necessary to complete a total system installation.

Flameless

The NIBCO® Press System® is easier and safer to use because there is no flame, solder or flux required. Connections can even be made on a wet tube!

Reliable

With the NIBCO® Press System®, a watertight joint is formed between the EPDM seal and the crimped fitting or valve providing a permanent connection. Reliability you can count on ... NIBCO® Press Fittings are backed by a 107-year-old company and a 50-year written guarantee.

Approvals, Standards and Performance

The NIBCO® Press System® has undergone extensive and rigorous internal and external testing and meets various worldwide, industry and governmental standards and codes, including NSF-61, CSA and UPC. All valves and fittings are manufactured under a Quality Management System conforming to the current version of ISO-9001 standards. For a complete listing of testing criteria and results or certifications and approvals please contact NIBCO Technical Services or visit www.nibco.com.

Applications

The NIBCO® Press System® can be used in new construction or repair work and is designed for potable water, HVAC and process water systems for commercial, industrial and residential applications.

Professional Appearance

The NIBCO® Press System® creates a clean joint without the mess of excess solder or discoloration.

Joint Integrity

The NIBCO® Press System® uses engineered tools, jaws and chains that are tested and approved to ensure a consistent, reliable crimp.

NIBCO[®] **pres@system**[®] **Fittings**



ADAPTERS

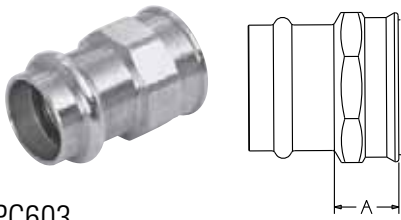

PC603
Adapter P x F – Brass Rod (*Wrot)

NOM. SIZE	APPROX. NET WT./LBS.	DIM. A INCHES
1/2	.097	1 ³ / ₁₆
*1/2 x 3/8	.081	2 ¹ / ₃₂
1/2 x 3/4	.151	3 ¹ / ₃₂
3/4	.162	2 ⁷ / ₃₂
3/4 x 1/2	.153	2 ⁵ / ₃₂
1	.237	1 ⁵ / ₁₆
*1 x 1/2	.129	3/4
1 x 3/4	.217	1 ³ / ₁₆
*1 x 1 1/4	.436	2 ¹ / ₄
1 1/4	.372	1 ¹ / ₁₆
1 1/4 x 1	.302	1 ¹ / ₁₆
*1 1/4 x 1 1/2	.602	2 ¹¹ / ₃₂
1 1/2	.518	1 ¹ / ₁₆
*1 1/2 x 3/4	.335	2 ¹ / ₈
1 1/2 x 1 1/4	.648	1
2	.714	1
*2 1/2	1.222	1 ¹³ / ₃₂
*3	1.884	1 ²³ / ₃₂
*4	3.238	1 ⁷ / ₈

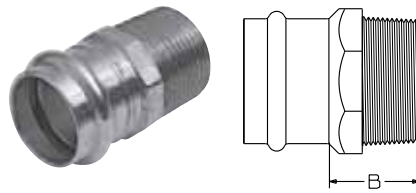

PC604
Adapter P x M – Brass Rod (*Wrot)

NOM. SIZE	APPROX. NET WT./LBS.	DIM. B INCHES
1/2	.106	7/8
*1/2 x 3/8	.105	2 ⁷ / ₃₂
1/2 x 3/4	.248	1 ¹ / ₄
3/4	.195	1 ¹ / ₁₆
3/4 x 1/2	.189	3 ¹ / ₃₂
1	.268	1 ³ / ₃₂
1 x 3/4	.253	1 ¹ / ₃₂
1 x 1 1/4	.662	1 ¹⁷ / ₃₂
1 1/4	.467	1 ¹³ / ₃₂
1 1/4 x 1	.408	1 ³ / ₁₆
1 1/4 x 1 1/2	.630	1 ¹ / ₂
1 1/2	.696	1 ¹ / ₂
1 1/2 x 1 1/4	.670	1 ³ / ₈
2	.927	1 ⁷ / ₁₆
*2 1/2	1.322	1 ²⁷ / ₃₂
*3	2.104	2 ¹ / ₈
*4	3.298	2 ⁹ / ₃₂

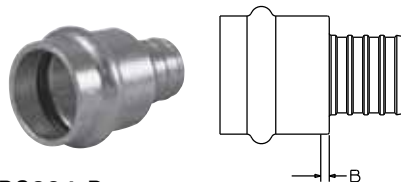

PC604-P
Adapter PEX x P – Wrot

NOM. SIZE	APPROX. NET WT./LBS.	DIM. B INCHES
1/2 x 1/2	.055	1/8
1/2 x 3/4	.108	13/64
3/4 x 1/2	.150	5/64
3/4 x 3/4	.108	5/32
1 x 1	.148	11/64

CAPS

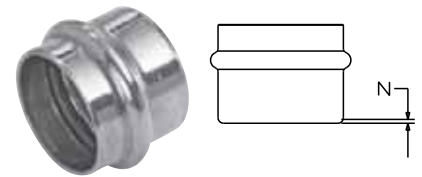

PC617
Cap P – Wrot

NOM. SIZE	APPROX. NET WT./LBS.	DIM. N INCHES
1/2	.046	5/32
3/4	.091	5/32
1	.125	1/8
1 1/4	.171	1/8
1 1/2	.314	3/16
2	.493	3/16
2 1/2	.476	7/32
3	.713	7/32
4	1.491	1/4

COUPLINGS

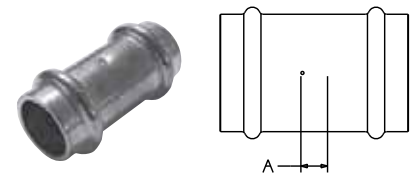

PC600-DS
Coupling P x P – Wrot

NOM. SIZE	APPROX. NET WT./LBS.	DIM. A INCHES
1/2	.080	3/16
3/4	.153	5/32
1	.190	5/32
1 1/4	.250	5/32
1 1/2	.511	3/16
2	.741	3/16
2 1/2	.669	1/8
3	.979	1/8
4	1.969	7/32

NOTE: Some items not certified by NSF to NSF/ANSI 61. See manufacturer's listing for approved sizes and applications, or contact NIBCO Technical Services for a complete listing of current certifications.

COUPLINGS (Cont.)

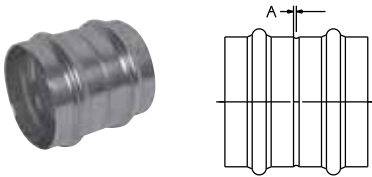

PC600-RS
Coupling P x P – Wrot

NOM. SIZE	APPROX. NET WT./LBS.	DIM. A INCHES
2 1/2	.688	1/16
3	.979	1/16
4	1.969	1/8

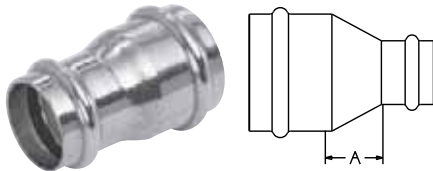

PC600-R
Reducing Coupling P x P – Wrot

NOM. SIZE	APPROX. NET WT./LBS.	DIM. A INCHES
3/4 x 1/2	.116	11/32
1 x 1/2	.159	11/32
1 x 3/4	.184	7/16
1 1/4 x 3/4	.245	5/16
1 1/4 x 1	.231	1/2
1 1/2 x 3/4	.382	1/2
1 1/2 x 1	.370	13/32
1 1/2 x 1 1/4	.399	1/14
2 x 3/4	.516	27/32
2 x 1	.552	11/16
2 x 1 1/4	.570	11/16
2 x 1 1/2	.662	7/16
2 1/2 x 1	.594	29/32
2 1/2 x 1 1/4	.587	13/16
2 1/2 x 1 1/2	.697	11/16
2 1/2 x 2	.735	9/16
3 x 1 1/2	.938	11/32
3 x 2	1.002	31/32
3 x 2 1/2	.951	1/2
4 x 2	1.935	1 1/4
4 x 2 1/2	1.807	1
4 x 3	1.960	27/32

COUPLINGS (Cont.)

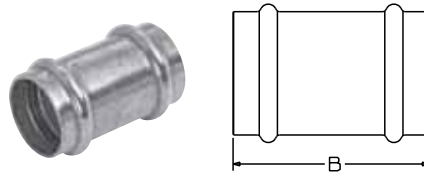

PC601 (No Stop)
Repair Coupling P x P – Wrot

NOM. SIZE	APPROX. NET WT./LBS.	DIM. B INCHES
1/2	.080	1 3/4
3/4	.151	2 1/4
1	.190	2 1/4
1 1/4	.250	2 15/32
1 1/2	.511	3 11/32
2	.741	3 5/8
2 1/2	.669	2 15/16
3	.979	3 5/16
4	1.878	4 5/16

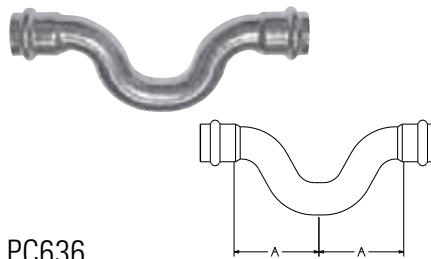

PC636
Crossover Coupling P x P – Wrot

NOM. SIZE	APPROX. NET WT./LBS.	DIM. A INCHES
1/2	0.402	1 29/32
3/4	.402	2 1/4

ELBOWS

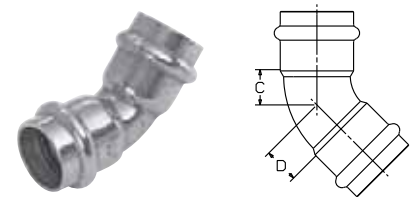

PC606
45° Elbow P x P – Wrot

NOM. SIZE	APPROX. NET WT./LBS.	DIM. C INCHES	DIM. D INCHES
1/2	.092	25/64	25/64
3/4	.204	31/64	31/64
1	.251	5/8	5/8
1 1/4	.378	25/32	25/32
1 1/2	.666	7/8	7/8
2	1.096	1 11/64	1 11/64
2 1/2	1.041	29/32	29/32
3	1.536	1 1/8	1 1/8
4	3.375	1 11/16	1 11/16

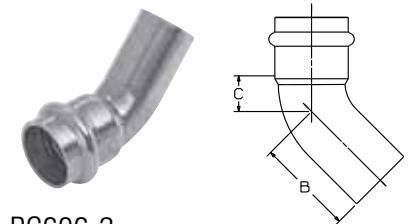

PC606-2
45° Elbow Ftg x P – Wrot

NOM. SIZE	APPROX. NET WT./LBS.	DIM. B INCHES	DIM. C INCHES
1/2	.086	1 11/32	1 1/32
3/4	.174	1 15/32	9/16
1	.248	1 19/32	9/16
1 1/4	.368	1 27/32	1 1/16
1 1/2	.673	2 3/8	7/8
2	1.098	2 5/8	1 3/32
2 1/2	1.050	2 3/16	29/32
3	1.526	2 19/32	1 5/32
4	3.284	3 3/32	1 1/2

NOTE: Some items not certified by NSF to NSF/ANSI 61. See manufacturer's listing for approved sizes and applications, or contact NIBCO Technical Services for a complete listing of current certifications.

ELBOWS (Cont.)

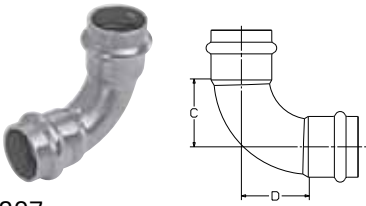

PC607
90° Elbow P x P – Wrot

NOM. SIZE	APPROX. NET WT./LBS.	DIM. C INCHES	DIM. D INCHES
1/2	.135	1 ³ / ₃₂	1 ³ / ₃₂
3/4	.223	1 ⁵ / ₆₄	1 ⁵ / ₆₄
3/4 x 1/2	.190	1 ³ / ₁₆	1 ¹ / ₁₆
1	.323	1 ⁷ / ₁₆	1 ⁷ / ₁₆
1 1/4	.554	1 ¹¹ / ₁₆	1 ¹¹ / ₁₆
1 1/2	.863	2 ¹³ / ₆₄	2 ¹³ / ₆₄
2	1.562	2 ¹⁵ / ₁₆	2 ¹⁵ / ₁₆
2 1/2	1.224	1 ²⁷ / ₃₂	1 ²⁷ / ₃₂
3	1.998	2 ³ / ₃₂	2 ³ / ₃₂
4	4.060	2 ²⁵ / ₃₂	2 ²⁵ / ₃₂

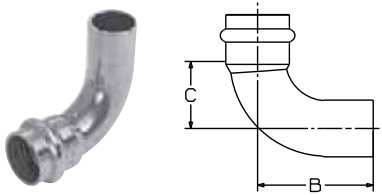

PC607-2
90° Elbow Ftg x P – Wrot

NOM. SIZE	APPROX. NET WT./LBS.	DIM. B INCHES	DIM. C INCHES
1/2	.125	1 ²³ / ₃₂	2 ⁵ / ₃₂
3/4	.212	2 ¹³ / ₆₄	1 ³ / ₆₄
1	.319	2 ¹ / ₂	1 ¹³ / ₃₂
1 1/4	.490	2 ³¹ / ₃₂	1 ⁷ / ₈
1 1/2	.871	3 ²¹ / ₃₂	2 ¹ / ₄
2	1.622	4 ¹⁵ / ₃₂	2 ¹⁵ / ₁₆
2 1/2	1.356	3 ¹⁵ / ₃₂	1 ²⁹ / ₃₂
3	2.065	3 ¹³ / ₁₆	2 ³ / ₃₂
4	3.920	4 ³ / ₄	2 ²⁵ / ₃₂

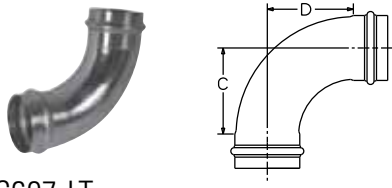

PC607-LT
90° Long Radius Elbow
P x P – Wrot

NOM. SIZE	APPROX. NET WT./LBS.	DIM. C INCHES	DIM. D INCHES
2 1/2	2.066	3 ¹¹ / ₁₆	3 ¹¹ / ₁₆
3	3.037	4 ¹ / ₃₂	4 ¹ / ₃₂
4	5.696	5 ¹ / ₄	5 ¹ / ₄

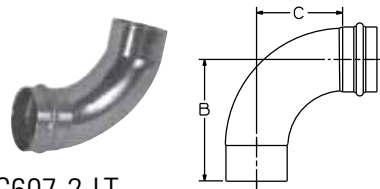

PC607-2-LT
90° Long Radius Elbow
Ftg x P - Wrot

NOM. SIZE	APPROX. NET WT./LBS.	DIM. B INCHES	DIM. C INCHES
2 1/2	2.114	5 ⁷ / ₃₂	3 ¹¹ / ₁₆
3	3.037	5 ³ / ₄	4 ¹ / ₃₂

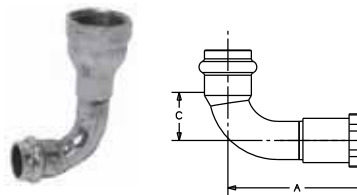

PC607-3
90° Elbow P x F - Wrot

NOM. SIZE	APPROX. NET WT./LBS.	DIM. A INCHES	DIM. C INCHES
1/2	.213	2 ¹³ / ₁₆	1 ³ / ₃₂
3/4	.361	3 ²¹ / ₆₄	1 ³ / ₆₄
1/2 x 3/8	.148	2 ¹ / ₄	2 ⁵ / ₃₂
1/2 x 3/4	.243	2 ¹³ / ₁₆	1 ³ / ₆₄
1	.513	3 ¹⁵ / ₃₂	1 ¹³ / ₃₂

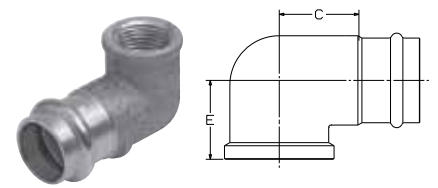

PC707-3
90° Elbow P x F – Cast

NOM. SIZE	APPROX. NET WT./LBS.	DIM. C INCHES	DIM. E INCHES
3/4 x 1/2	.318	1 ³ / ₆₄	1 ⁵³ / ₆₄
1 1/4	.901	1 ¹⁹ / ₃₂	1 ¹⁹ / ₃₂
1 1/2	1.327	1 ¹⁹ / ₃₂	1 ¹¹ / ₁₆
2	1.327	2 ¹ / ₄	2 ⁵ / ₃₂

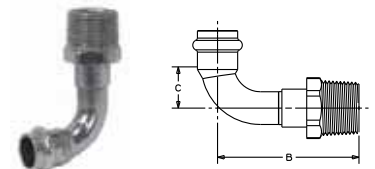

PC607-4
90° Elbow P x M - Wrot

NOM. SIZE	APPROX. NET WT./LBS.	DIM. B INCHES	DIM. C INCHES
1/2 x 3/4	.245	2 ¹¹ / ₁₆	2 ⁵ / ₃₂
3/4	.373	3 ¹ / ₆₄	1 ³ / ₆₄
3/4 x 1/2	.340	3 ³ / ₆₄	1 ³ / ₆₄
1 1/2	1.433	4 ³¹ / ₃₂	2 ⁹ / ₃₂
2	2.080	6 ²¹ / ₃₂	2 ⁵⁹ / ₆₄

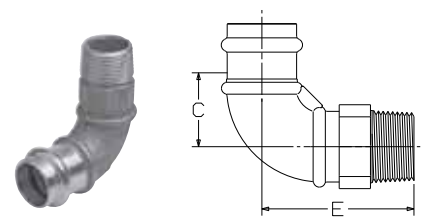

PC707-4
90° Elbow P x M – Cast

NOM. SIZE	APPROX. NET WT./LBS.	DIM. C INCHES	DIM. E INCHES
1/2	.263	1 ¹ / ₈	1 ²³ / ₃₂
1	.714	1 ¹¹ / ₃₂	2 ¹³ / ₁₆
1 1/4	1.273	1 ¹³ / ₁₆	3 ¹ / ₂

NOTE: Some items not certified by NSF to NSF/ANSI 61. See manufacturer's listing for approved sizes and applications, or contact NIBCO Technical Services for a complete listing of current certifications.

ELBOWS (Cont.)

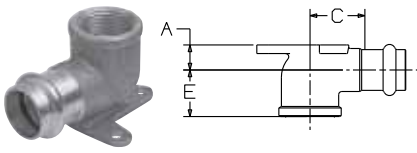

PC707-3-5
90° Drop Elbow P x F – Cast

NOM. SIZE	APPROX. NET WT. LBS.	DIMENSIONS INCHES		
		A	C	E
1/2	.172	17/32	7/8	27/32
3/4	.316	11/16	1 1/4	31/32

FITTING REDUCERS

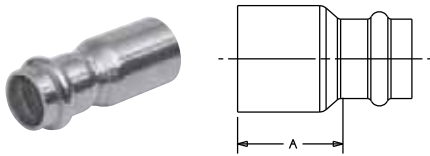

PC600-2
Fitting Reducer Ftg x P – Wrot

NOM. SIZE	APPROX. NET WT./LBS.	DIM. A INCHES
3/4 x 1/2	.108	1 3/8
1 x 1/2	.133	1 15/32
1 x 3/4	.167	1 1/32
1 1/4 x 3/4	.211	5/16
1 1/4 x 1	.191	1 15/32
1 1/2 x 1/2	.242	37/64
1 1/2 x 3/4	.298	15/32
1 1/2 x 1	.294	1 13/16
1 1/2 x 1 1/4	.311	1 3/4
2 x 1/2	.443	2 1/4
2 x 3/4	.470	3/4
2 x 1	.433	2 7/32
2 X 1 1/4	.459	1 15/16
2 x 1 1/2	.543	1 7/8
2 1/2 x 1	.507	2 11/32
2 1/2 x 1 1/4	.658	2 9/32
2 1/2 x 1 1/2	.806	2 13/32
2 1/2 x 2	.810	1 31/32
3 x 1 1/4	.882	3 9/32
3 x 1 1/2	.812	2 5/8
3 x 2	1.041	2 9/16
3 x 2 1/2	.820	2 1/4
4 x 2	1.670	3 13/32
4 x 2 1/2	1.837	3 1/32
4 x 3	2.013	3 1/32

FLANGES

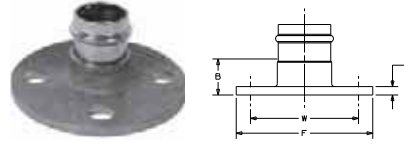

PC741
Companion Flange
P x Flange - Bronze Flange/Wrot
Outlet

NOM. SIZE	APPROX. NET WT. LBS.	DIMENSIONS INCHES			
		B	F	G	W
1	1.419	1 5/32	4 1/4	1/4	3 1/8
1 1/4	1.632	1 5/16	4 5/8	1/4	3 1/2
1 1/2	2.186	1 7/16	5	5/16	3 7/8
2	3.352	1 11/16	6	3/8	4 3/4

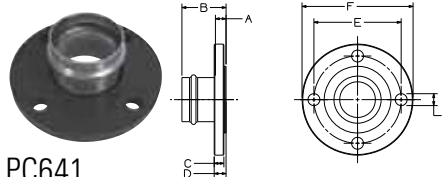

PC641
Companion Flange
P x Flange - Wrot

NOM. SIZE	APPROX. NET WT. LBS.	DIMENSIONS INCHES		
		A	B	C
2 1/2	6.177	1 9/32	2 25/32	5/8
3	7.554	3/4	2 15/16	2 1/32
4	11.211	2 9/32	3 3/8	2 7/32

NOM. SIZE	DIMENSIONS INCHES			
	D	E	F	G
2 1/2	3/4	5 1/2	7	3/4
3	1 3/16	6	7 1/2	3/4
4	1	7 1/2	9	3/4

NOTE: 4" requires (8) "G" holes equally spaced.
NOTE: Mates with ANSI Class 125/150 flanges.

MANIFOLDS

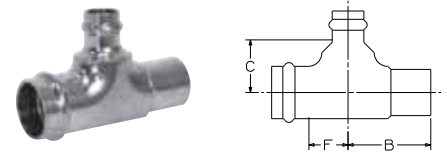

PC695
1-Outlet Manifold
P x Ftg x P - Wrot

NOM. SIZE	APPROX. NET WT. LBS.	DIMENSIONS INCHES		
		B	C	F
1 x 1 x 1/2	.504	1 15/16	1 1/8	1 5/16

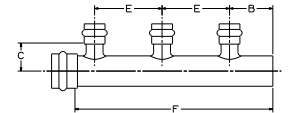

PC696
3-Outlet Manifold
P x Ftg x P - Wrot

NOM. SIZE	APPROX. NET WT. LBS.	DIMENSIONS INCHES			
		B	C	E	F
1 x 1 x 1/2	.882	1 21/32	3/4	1 31/32	6 3/8

*See online catalog at www.nibco.com

Cont. next page

NOTE: Some items not certified by NSF to NSF/ANSI 61. See manufacturer's listing for approved sizes and applications, or contact NIBCO Technical Services for a complete listing of current certifications.

TEES

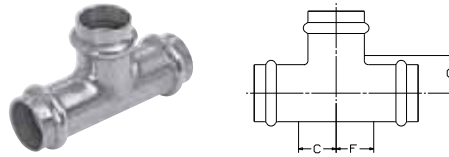

PC611
Tee P x P x P – Wrot

NOM. SIZE	APPROX. NET WT. LBS.	DIMENSIONS INCHES		
		C	F	G
1/2	.182	11/16	11/16	15/32
1/2 x 1/2 x 3/4	.261	13/16	13/16	5/8
1/2 x 1/2 x 1	.491	17/32	17/32	63/64
3/4	.340	23/32	23/32	5/8
3/4 x 1/2 x 1/2	.329	23/32	13/16	11/16
3/4 x 1/2 x 3/4	.333	23/32	13/16	5/8
3/4 x 3/4 x 1/2	.339	23/32	23/32	11/16
3/4 x 3/4 x 1	.461	13/32	13/32	29/32
1	.486	7/8	7/8	29/32
1 x 1/2 x 1	.513	15/16	13/16	29/32
1 x 3/4 x 1/2	.368	7/8	13/32	13/16
1 x 3/4 x 3/4	.465	7/8	13/32	11/16
1 x 3/4 x 1	.521	7/8	11/8	29/32
1 x 1 x 1/2	.457	7/8	7/8	17/32
1 x 1 x 3/4	.480	27/32	27/32	11/16
1 x 1 x 1 1/4	.723	17/32	17/32	29/32
1 1/4	.714	1	1	29/32
1 1/4 x 1 x 3/4	.753	1	17/32	13/8
1 1/4 x 1 x 1	.725	1	19/64	117/64
1 1/4 x 1 1/4 x 1/2	.747	1	1	17/16
1 1/4 x 1 1/4 x 3/4	.767	1	1	13/8
1 1/4 x 1 1/4 x 1	.690	1	1	1 1/4
1 1/2	1.179	15/16	15/16	13/32
1 1/2 x 1/2 x 1 1/2	1.227	31/32	17/8	1
1 1/2 x 3/4 x 3/4	1.101	61/64	155/64	113/16
1 1/2 x 1 x 3/4	1.101	61/64	111/16	113/16
1 1/2 x 1 x 1	1.105	1	147/64	141/64
1 1/2 x 1 x 1 1/2	1.146	31/32	15/8	1
1 1/2 x 1 1/4 x 1	1.105	61/64	141/64	15/8
1 1/2 x 1 1/4 x 1 1/4	1.160	31/32	17/16	115/32
1 1/2 x 1 1/2 x 1/2	1.209	15/16	15/16	131/32
1 1/2 x 1 1/2 x 3/4	1.070	15/16	15/16	113/16
1 1/2 x 1 1/2 x 1	1.074	15/16	15/16	1 19/32
1 1/2 x 1 1/2 x 1 1/4	1.166	61/64	61/64	111/16
2	1.771	113/32	113/32	113/32
2 x 1/2 x 2	1.663	113/32	23/8	113/32
2 x 1 x 1	1.764	123/64	21/4	27/32
2 x 1 x 2	1.564	113/32	27/32	127/32
2 x 1 1/4 x 1 1/4	1.471	113/32	127/32	17/8

NOM. SIZE	APPROX. NET WT. LBS.	DIMENSIONS INCHES		
		C	F	G
2 x 1 1/2 x 3/4	1.542	113/32	111/16	27/32
2 x 1 1/2 x 1	1.546	113/32	123/32	23/32
2 x 1 1/2 x 1 1/4	1.543	113/32	111/16	21/16
2 x 1 1/2 x 1 1/2	1.670	113/32	123/32	123/32
2 x 2 x 1/2	1.576	113/32	113/32	25/16
2 x 2 x 3/4	1.573	113/32	113/32	29/32
2 x 2 x 1	1.633	113/32	113/32	27/32
2 x 2 x 1 1/4	1.576	113/32	113/32	131/32
2 x 2 x 1 1/2	1.770	11/8	11/8	17/16
2 1/2	2.082	15/8	15/8	15/8
2 1/2 x 3/4 x 2 1/2	2.296	19/16	23/16	17/8
2 1/2 x 1 x 2 1/2	2.297	19/16	219/32	17/8
2 1/2 x 1 1/4 x 2 1/2	2.202	19/16	219/32	17/8
2 1/2 x 1 1/2 x 2 1/2	2.223	19/16	21/4	17/8
2 1/2 x 2 x 3/4	2.233	19/16	21/4	229/32
2 1/2 x 2 x 1	2.090	19/16	21/4	219/32
2 1/2 x 2 x 1 1/4	2.151	19/16	21/4	29/16
2 1/2 x 2 x 1 1/2	2.155	19/16	21/4	25/8
2 1/2 x 2 x 2	2.694	19/16	21/4	21/4
2 1/2 x 2 x 2 1/2	2.282	19/16	21/32	17/8
2 1/2 x 2 1/2 x 1/2	2.296	19/16	19/16	31/16
2 1/2 x 2 1/2 x 3/4	2.029	19/16	19/16	31/16
2 1/2 x 2 1/2 x 1	2.089	19/16	19/16	29/16
2 1/2 x 2 1/2 x 1 1/4	2.066	19/16	19/16	25/8
2 1/2 x 2 1/2 x 1 1/2	2.078	19/16	19/16	25/8
2 1/2 x 2 1/2 x 2	2.531	19/16	19/16	27/32
3	3.122	17/8	17/8	21/32
3 x 3/4 x 3	3.136	113/16	31/4	23/16
3 x 1 x 3	3.146	113/16	39/32	23/16
3 x 1 1/4 x 3	3.070	113/16	27/8	23/16
3 x 1 1/2 x 3	3.110	113/16	215/16	23/16
3 x 2 x 2	3.158	113/16	213/16	225/32
3 x 2 x 2 1/2	3.089	113/16	213/16	21/2
3 x 2 x 3	3.164	113/16	211/16	23/16
3 x 2 1/2 x 2	3.153	113/16	215/32	225/32
3 x 2 1/2 x 2 1/2	3.010	113/16	215/32	21/2
3 x 2 1/2 x 3	3.194	113/16	215/32	23/16
3 x 3 x 1/2	2.891	113/16	113/16	33/8
3 x 3 x 3/4	2.462	113/16	113/16	313/32

NOM. SIZE	APPROX. NET WT. LBS.	DIMENSIONS INCHES		
		C	F	G
3 x 3 x 1	2.978	113/16	113/16	31/4
3 x 3 x 1 1/4	2.963	113/16	113/16	215/16
3 x 3 x 1 1/2	3.006	113/16	113/16	3
3 x 3 x 2	3.113	113/16	113/16	215/32
3 x 3 x 2 1/2	3.034	129/32	129/32	23/8
4	7.169	213/32	213/32	217/32
4 x 2 x 4	7.332	23/8	41/32	223/32
4 x 2 1/2 x 4	6.984	23/8	325/32	223/32
4 x 3 x 2	7.160	23/8	39/16	33/4
4 x 3 x 2 1/2	6.990	23/8	39/16	329/32
4 x 3 x 3	7.085	23/8	39/16	31/2
4 x 3 x 4	6.993	23/8	323/32	223/32
4 x 4 x 1/2	6.770	23/8	23/8	415/32
4 x 4 x 3/4	6.756	23/8	23/8	41/8
4 x 4 x 1	6.929	23/8	23/8	45/32
4 x 4 x 1 1/4	6.902	23/8	23/8	41/32
4 x 4 x 1 1/2	7.099	23/8	23/8	33/4
4 x 4 x 2	7.072	23/8	23/8	315/16
4 x 4 x 2 1/2	6.925	23/8	23/8	329/32
4 x 4 x 3	7.083	23/8	23/8	31/2

TEES (Cont.)

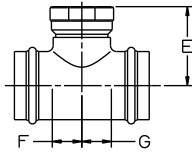

PC612
Tee P x P x F – Wrot

NOM. SIZE	APPROX. NET WT./LBS.	DIMENSIONS INCHES		
		E	F	G
1/2	.266	1 ³¹ / ₃₂	1 ¹¹ / ₁₆	1 ¹¹ / ₁₆
3/4 x 3/4 x 1/2	.423	2 ⁵ / ₈	2 ³ / ₃₂	2 ³ / ₃₂
1 x 1 x 1/2	.541	2 ¹¹ / ₁₆	7/8	7/8
1 x 1 x 3/4	.673	2 ²⁷ / ₃₂	2 ⁷ / ₃₂	2 ⁷ / ₃₂
1 1/4 x 1 1/4 x 1/2	.832	2 ⁷ / ₈	1	1
1 1/4 x 1 1/4 x 3/4	.922	3 ¹ / ₁₆	1	1
1 1/2 x 1 1/2 x 1/2	1.141	3 ¹⁹ / ₆₄	1 ⁵ / ₁₆	1 ⁵ / ₁₆
1 1/2 x 1 1/2 x 3/4	1.291	3 ³ / ₈	3 ¹ / ₃₂	3 ¹ / ₃₂
2 x 2 x 1/2	1.699	3 ¹³ / ₁₆	1 ¹³ / ₃₂	1 ¹³ / ₃₂
2 x 2 x 3/4	1.693	3 ³¹ / ₃₂	1 ¹³ / ₃₂	1 ¹³ / ₃₂
2 1/2 x 2 1/2 x 3/4	1.049	2 ¹⁵ / ₃₂	1 ¹¹ / ₁₆	1 ¹¹ / ₁₆
2 1/2 x 2 1/2 x 2	1.925	3 ⁷ / ₃₂	1 ⁹ / ₃₂	1 ⁹ / ₃₂
3 x 3 x 3/4	1.435	2 ³ / ₄	1 ¹¹ / ₁₆	1 ¹¹ / ₁₆
3 x 3 x 2	2.097	3 ¹⁵ / ₃₂	1 ⁹ / ₃₂	1 ⁹ / ₃₂
4 x 4 x 3/4	2.786	3 ¹ / ₄	1 ¹¹ / ₁₆	1 ¹¹ / ₁₆
4 x 4 x 2	3.675	4	1 ⁹ / ₃₂	1 ⁹ / ₃₂

UNIONS

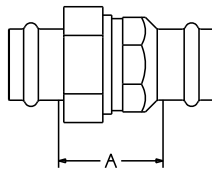

PC633
Union P x P – Wrot

NOM. SIZE	APPROX. NET WT./LBS.	DIM. A INCHES
1/2	.383	1 ⁵ / ₁₆
3/4	.590	1 ⁹ / ₃₂
1	.850	1 ¹¹ / ₃₂
1 1/4	1.126	1 ³⁷ / ₆₄
1 1/2	1.723	1 ⁵ / ₈
2	2.627	1 ²⁷ / ₃₂

UNIONS (Cont.)

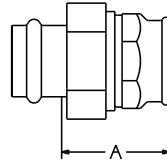

PC733-3
Union P x F – Brass Rod

NOM. SIZE	APPROX. NET WT./LBS.	DIM. A INCHES
1 1/4	1.098	1 ⁵⁹ / ₆₄
1 1/2	1.885	1 ⁵⁵ / ₆₄

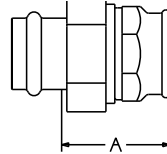

PC633-3
Union P x F – Wrot

NOM. SIZE	APPROX. NET WT./LBS.	DIM. A INCHES
1/2	.374	1 ⁷ / ₁₆
3/4	.559	1 ¹⁷ / ₃₂
1	.918	1 ³⁹ / ₆₄
2	2.445	2 ¹¹ / ₆₄

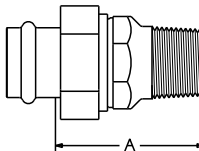

PC733-4
Union P x M – Brass Rod

NOM. SIZE	APPROX. NET WT./LBS.	DIM. A INCHES
1 1/4	1.269	2 ²⁵ / ₆₄

PC633-4
Union P x M – Wrot

NOM. SIZE	APPROX. NET WT./LBS.	DIM. A INCHES
1/2	.397	1 ¹³ / ₁₆
3/4	.574	1 ²⁹ / ₃₂
1	.904	2 ⁵ / ₃₂
1 1/2	1.769	2 ¹¹ / ₃₂
2	2.789	2 ⁴⁹ / ₆₄

ACCESSORIES



EPDM Seal

SIZE	PART No.
1/2	T048052
3/4	T048054
1	T048056
1 1/4	T048058
1 1/2	T048060
2	T048062
2 1/2	T048064
3	T048066
4	T048070



EPDM Seal (leak detection)

SIZE	PART No.
1/2	T048352
3/4	T048354
1	T048356
1 1/4	T048358
1 1/2	T048360
2	T048362

NIBCO[®] pres@system[®] Valves



NIBCO® Press System® Illustrated Valve Index

<p>PC585-70 PC585-70-66 Bronze Ball Valve</p>  <ul style="list-style-type: none"> • Press x Press Female End • Full Port, Blowout-Proof Stem • Standard Lever Handle • 250 PSI CWP • Sizes 1/2" thru 2" <p>Page 13, 14</p>	<p>PC585-70-NS PC585-70-66-NS Bronze Ball Valve</p>  <ul style="list-style-type: none"> • Press Female End x Hose • Full Port, Blowout-Proof Stem • NIB-SEAL® Handle • 250 PSI CWP • Sizes 1/2" thru 2" <p>Page 15, 16</p>
<p>PC585-70-LL PC585-70-66-LL Bronze Ball Valve</p>  <ul style="list-style-type: none"> • Press x Press Female End • Full Port, Blowout-Proof Stem • Locking Lever Handle • 250 PSI CWP • Sizes 1/2" thru 2" <p>Page 17, 18</p>	<p>PC585-70-HC PC585-70-66-HC Bronze Ball Valve</p>  <ul style="list-style-type: none"> • Press Female End x Hose • Full Port, Blowout-Proof Stem • Standard Lever Handle • Blow Down, End of Line • Hose Cap with Chain • 250 PSI CWP • Sizes 1/2" and 3/4" <p>Page 19, 20</p>
<p>PC585-80-LF PC585-66-LF Bronze Ball Valve</p>  <ul style="list-style-type: none"> • Lead-Free* • Press x Press Female End • Full Port, Blowout-Proof Stem • Standard Lever Handle • 250 PSI CWP • Sizes 1/2" thru 2" <p>Page 21, 22</p>	<p>PFFP-600 Brass Ball Valve</p>  <ul style="list-style-type: none"> • Press x Press Female End • Full Port, Blowout-Proof Stem • Standard Lever Handle • 600 PSI CWP • Sizes 1/2" thru 2" <p>Page 23</p>
<p>PF111 Bronze Gate Valve</p>  <ul style="list-style-type: none"> • Press x Press Female End • Rising Stem • 200 PSI CWP • Sizes 1/2" thru 2" <p>Page 24</p>	<p>PF113 Bronze Gate Valve</p>  <ul style="list-style-type: none"> • Press x Press Female End • Non-Rising Stem • 200 PSI CWP • Sizes 1/2" thru 2" <p>Page 25</p>

Note: Ball valves are down-rated from 600 PSI CWP to 200 PSI CWP to match the Press System.

*Lead Free refers to the wetted surface of pipe, fittings and fixtures in potable water systems that have a weighted average lead content $\leq 0.25\%$ per the Safe Drinking Water Act (Sec. 1417) amended 1-4-2011 and other equivalent state regulations.

NIBCO® Press System® Illustrated Valve Index

<p>PF211-Y Bronze Globe Valve</p>  <ul style="list-style-type: none"> • Press x Press Female End • PTFE Resilient Seat • 200 PSI CWP • Sizes 1/2" thru 2" <p>Page 26</p>	<p>PF311-Y Bronze Angle Valve</p>  <ul style="list-style-type: none"> • Press x Press Female End • PTFE Resilient Seat • 200 PSI CWP • Sizes 1/2" thru 2" <p>Page 27</p>
<p>PF413-Y Bronze Swing Check Valve</p>  <ul style="list-style-type: none"> • Press x Press Female End • PTFE Seat • 200 PSI CWP • Sizes 1/2" thru 2" <p>Page 28</p>	<p>PF480-Y Bronze In-Line Check Valve</p>  <ul style="list-style-type: none"> • Press x Press Female End • PTFE Seat, Stainless Internals • 250 PSI CWP • Sizes 1/2" thru 2" <p>Page 29</p>
<p>PFD2000 Series Ductile Iron Butterfly Valve</p>  <ul style="list-style-type: none"> • Press x Press Female End • Molded-in Liner • Aluminum Bronze Disc • Standard Lever Handle or Gear Operated • 200 PSI CWP • Sizes 2 1/2" thru 4" <p>Page 30</p>	<p>PS585-70 PS585-70-66 Bronze Ball Valve</p>  <ul style="list-style-type: none"> • Press x Press Male End • 2" Type L Copper • Full Port, Blowout-Proof Stem • Standard Lever Handle • 600 PSI CWP • Sizes 1/2" thru 2" <p>Page 31, 32</p>
<p>PS585-70-HC Bronze Ball Valve</p>  <ul style="list-style-type: none"> • Press x Press Male End • 2" Type L Copper • Full Port, Blowout-Proof Stem • Standard Lever Handle • Blown Down, End of Line • Hose Cap with Chain • 600 PSI CWP • Sizes 1/2" and 3/4" <p>Page 33</p>	<p>PF221/222-A/B Bronze Y-Strainer</p>  <ul style="list-style-type: none"> • Press x Press Female End • Tapped cap w/ blow-off plug or solid cap • 20 Mesh SS Screen or SS Perforated Screen • 200 PSI CWP • Sizes 1/2" thru 2" <p>Page 34</p>

Note: Ball valves are down-rated from 600 PSI CWP to 200 PSI CWP to match the Press System.

Note: Check valves are down-rated from 250 PSI CWP to 200 PSI CWP to match the Press System.

NIBCO® Press System® Bronze Ball Valves

Two-Piece Body • Full Port • Bronze Trim • Blowout-Proof Stem

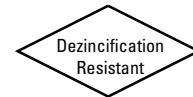

250 PSI/17.2 Bar Non-Shock Cold Working Pressure
250°F Maximum Operating Temperature

CONFORMS TO MSS SP-110

MATERIAL LIST

PART	SPECIFICATION
1. Body	Bronze ASTM B584 Alloy C84400
2. Body End	Bronze ASTM B584 Alloy C84400
3. Press End Adapter (2)	Bronze ASTM B61 Alloy C92200
4. Ball	Brass ASTM B16 Alloy C36000 or ASTM B283 Alloy C37700 (Chrome/Nickel Plated)
5. Seat Ring (2)	Reinforced PTFE
6. Boss seal o-ring (2)	EPDM
7. O-Ring (2)	EPDM
8. Packing	PTFE
9. Pack Gland	Brass ASTM B16 Alloy C36000
10. Stem	Silicon Bronze ASTM B371 Alloy C69430 or ASTM B371 Alloy C69430
11. Handle Nut	Zinc Plated Steel
12. Thrust Washer	Reinforced PTFE
13. Handle Assembly	Zinc Plated Steel with Plastisol Coating



PC585-70

Press x Press
Female End

DIMENSIONS—WEIGHTS

SIZE	Dimensions						Weight						
	A	B	C	D	E	Lbs.	Kg.						
1/2"	13	2.76	70	1.90	48	6.00	152	.50	13	4.15	105	.80	.36
3/4"	19	3.28	83	2.28	58	7.29	185	.75	19	5.05	128	1.56	.71
1"	25	3.59	91	2.41	61	7.34	186	1.00	25	5.36	136	2.13	1.00
1 1/4"	32	4.62	117	3.05	77	10.04	255	1.25	32	6.64	169	3.73	1.69
1 1/2"	38	5.23	133	3.30	84	10.72	272	1.50	38	8.00	203	5.53	2.51
2"	50	5.63	143	3.51	89	11.05	281	2.00	50	8.65	220	7.95	3.61

NIBCO® Press System® ball valves are designed to meet MSS SP-110 with the exception of the end connection. Ball valves are down-rated from 600 PSI CWP to 250 PSI CWP to match the Press System®. Male and female press-to-connect ends are new technology not yet covered in the current edition of this specification.

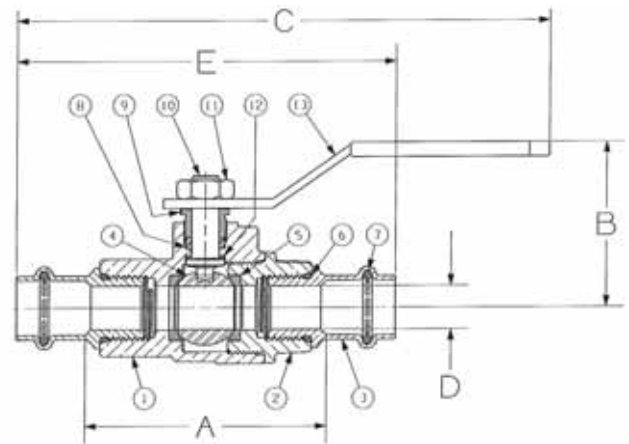

PC585-70
P x P

NIBCO® Press System® Bronze Ball Valves

Two-Piece Body • Full Port • Stainless Trim • Blowout-Proof Stem • Vented Ball



250 PSI/17.2 Bar Non-Shock Cold Working Pressure
250°F Maximum Operating Temperature

CONFORMS TO MSS SP-110

MATERIAL LIST

PART	SPECIFICATION
1. Body	Bronze ASTM B584 Alloy C84400
2. Body End	Bronze ASTM B584 Alloy C84400
3. Female Adapter (2)	Bronze ASTM B61 Alloy C92200
4. Ball (vented)	Stainless Steel ASTM A276 Type 316 or ASTM A351 Type CF8M
5. Seat Ring (2)	Reinforced PTFE
6. Boss Seal O-Ring (2)	EPDM
7. O-Ring (2)	EPDM
8. Packing	PTFE
9. Pack Gland	Brass ASTM B16 Alloy C36000
10. Stem	Stainless Steel ASTM A276 Type 316
11. Handle Nut	300 Series Stainless Steel
12. Thrust Washer	Reinforced PTFE
13. Handle Assembly	Zinc Plated Steel with Plastisol Coating



PC585-70-66

Press x Press
Female End

DIMENSIONS—WEIGHTS

SIZE	Dimensions										Weight		
	A		B		C		D		E		Lbs.	Kg.	
In. mm.	In.	mm.	In.	mm.	In.	mm.	In.	mm.	In.	mm.			
1/2"	13	2.76	70	1.90	48	6.00	152	.50	13	4.15	105	.77	.35
3/4"	19	3.28	83	2.28	58	7.29	185	.75	19	5.05	128	1.55	.70
1"	25	3.59	91	2.40	61	7.34	186	1.00	25	5.36	136	2.29	1.04
1 1/4"	32	4.62	117	3.05	77	10.04	255	1.25	32	6.64	169	3.80	1.72
1 1/2"	38	5.23	133	3.30	84	10.72	272	1.50	38	8.00	203	5.60	2.54
2"	50	5.63	143	3.51	89	11.05	281	2.00	50	8.65	220	8.69	3.94

NIBCO® Press System® ball valves are designed to meet MSS SP-110 with the exception of the end connection. Ball valves are down-rated from 600 PSI CWP to 250 PSI CWP to match the Press System®. Male and female press-to-connect ends are new technology not yet covered in the current edition of this specification.

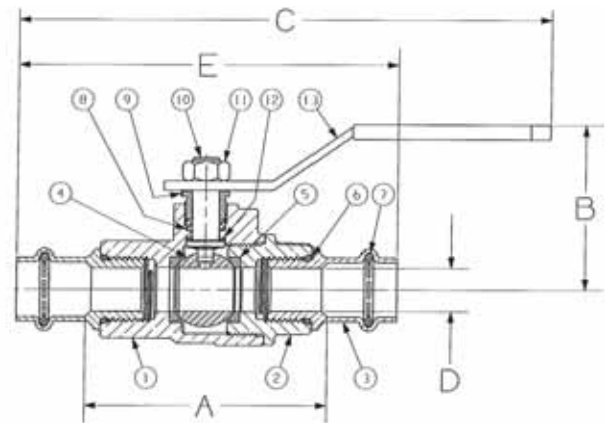

PC585-70-66
P x P

NIBCO® Press System® Bronze Ball Valves

Two-Piece Body • Full Port • NIB-SEAL® Handle

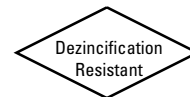

250 PSI/17.2 Bar Non-Shock Cold Working Pressure
250°F Maximum Operating Temperature

CONFORMS TO MSS SP-110

MATERIAL LIST

PART	SPECIFICATION
1. Body	Bronze ASTM B584 Alloy C84000
2. Body End	Bronze ASTM B584 Alloy C84400
3. Female Adapter (2)	Bronze ASTM B61 Alloy C92200
4. Ball	Brass ASTM B16 Alloy C36000 or ASTM B283 Alloy C37700 (Chrome/Nickel Plated)
5. Seat Ring (2)	Reinforced PTFE
6. Boss Seal O-Ring (2)	EPDM
7. O-Ring (2)	EPDM
8. Packing	PTFE
9. Thread Pack Gland	Brass ASTM B16 Alloy C36000
10. Stem	Silicon Bronze ASTM B371 Alloy C69300 or ASTM B371 Alloy C69430
11. Handle Nut	Zinc Plated Steel
12. Thrust Washer	Reinforced PTFE
13. NIB-SealHandle Assembly	Zinc Plated Steel & Plastic



PC585-70-NS

Press x Press
Female End

DIMENSIONS—WEIGHTS

SIZE	Dimensions						Weight						
	A		B		C		D		E				
In. mm.	In.	mm.	In.	mm.	In.	mm.	In.	mm.	In.	mm.	Lbs.	Kg.	
1/2"	13	2.76	70	3.55	90	4.25	108	.50	13	4.15	105	.88	.40
3/4"	19	3.28	83	3.84	98	4.25	108	.75	19	5.05	128	1.62	.73
1"	25	3.59	91	4.03	102	4.25	108	1.00	25	5.36	136	2.18	.99
1 1/4"	32	4.62	117	5.19	132	6.5	165	1.25	32	6.64	169	3.53	1.60
1 1/2"	38	5.23	133	5.44	138	6.5	165	1.50	38	8.00	203	5.61	2.54
2"	50	5.63	143	5.66	144	6.5	165	2.00	50	8.65	220	8.03	3.64

NIBCO® Press System® ball valves are designed to meet MSS SP-110 with the exception of the end connection. Ball valves are down-rated from 600 PSI CWP to 250 PSI CWP to match the Press System®. Male and female press-to-connect ends are new technology not yet covered in the current edition of this specification.

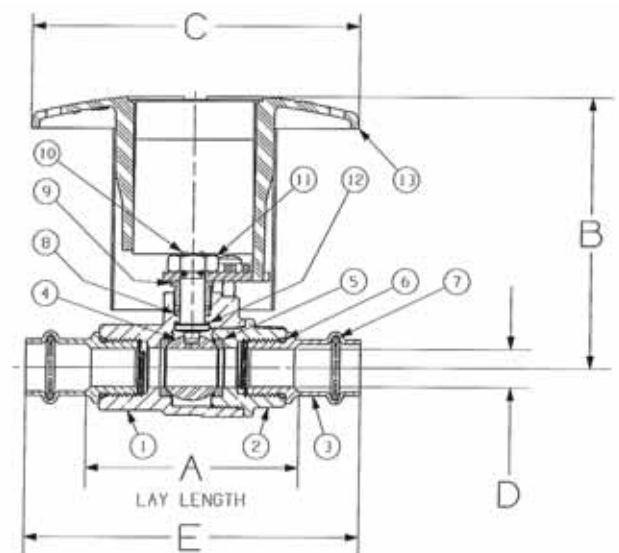

PC585-70-NS
P x P

NIBCO® Press System® Bronze Ball Valves

Two-Piece Body • Full Port • 316 SS Ball & Stem • NIB-SEAL® Handle • Vented Ball

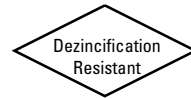

250 PSI/17.2 Bar Non-Shock Cold Working Pressure
250°F Maximum Operating Temperature

CONFORMS TO MSS SP-110

CONFORMS TO MSS SP-110

MATERIAL LIST

PART	SPECIFICATION
1. Body	Bronze ASTM B584 Alloy C84400
2. Body End	Bronze ASTM B584 Alloy C84400
3. Female Adapter (2)	Bronze ASTM B61 Alloy C92200
4. Ball (vented)	ASTM A276 Type 316 Stainless Steel or ASTM A351 Type CF8M
5. Seat Ring (2)	Reinforced PTFE
6. Boss Seal O-Ring (2)	EPDM
7. O-Ring (2)	EPDM
8. Packing	PTFE
9. Pack Gland	Brass ASTM B16 Alloy C36000
10. Stem	ASTM A276 Alloy Type 316 Stainless Steel
11. Handle Nut	300 Series Stainless Steel
12. Thrust Washer	Reinforced PTFE
13. NIB-SealHandle Assembly	Zinc Plated Steel & Plastic



PC585-70-66-NS

Press x Press
Female End

DIMENSIONS—WEIGHTS

SIZE	Dimensions										Weight		
	A		B		C		D		E		Lbs.	Kg.	
In.	mm.	In.	mm.	In.	mm.	In.	mm.	In.	mm.	In.	mm.		
1/2"	13	2.76	70	3.55	90	4.25	108	.50	13	4.15	105	.90	.41
3/4"	19	3.28	83	3.84	98	4.25	108	.75	19	5.05	128	1.60	.73
1"	25	3.59	91	4.03	102	4.25	108	1.00	25	5.36	136	2.34	1.06
1 1/4"	32	4.62	117	5.19	132	6.50	165	1.25	32	6.69	169	3.88	1.76
1 1/2"	38	5.23	133	5.44	138	6.50	165	1.50	38	8.00	205	5.68	2.58
2"	50	5.63	143	5.66	144	6.50	165	2.00	50	8.65	220	8.77	3.98

NIBCO® Press System® ball valves are designed to meet MSS SP-110 with the exception of the end connection. Ball valves are down-rated from 600 PSI CWP to 250 PSI CWP to match the Press System®. Male and female press-to-connect ends are new technology not yet covered in the current edition of this specification.

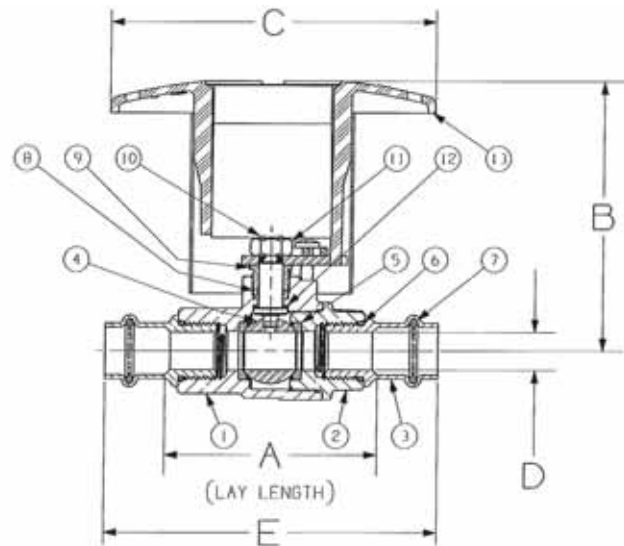

PC585-70-66-NS
P x P

NIBCO® Press System® Bronze Ball Valves

Two-Piece Body • Full Port • Bronze Trim • Blowout-Proof Stem • Locking Handle

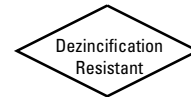

250 PSI/17.2 Bar Non-Shock Cold Working Pressure
250°F Maximum Operating Temperature

CONFORMS TO MSS SP-110

MATERIAL LIST

PART	SPECIFICATION
1. Body	Bronze ASTM B584 Alloy C84400
2. Body End	Bronze ASTM B584 Alloy C84400
3. Female Adapter (2)	Bronze ASTM B61 Alloy C92200
4. Ball	Brass ASTM B16 Alloy C36000 or ASTM B283 C37700 (Chrome/Nickel Plated)
5. Seat Ring (2)	Reinforced PTFE
6. Boss Seal O-Ring (2)	EPDM
7. O-Ring (2)	EPDM
8. Packing	PTFE
9. Pack Gland	Brass ASTM B16 Alloy C36000
10. Stem	Silicon Bronze ASTM B371 Alloy C69300 or ASTM B371 Alloy C69430
11. Handle Nut	Zinc Plated Steel
12. Thrust Washer	Reinforced PTFE
13. Locking Handle	Zinc Plated Steel with Plastisol Coating
14. Locking Device	300 Series Stainless Steel



PC585-70-LL

Press x Press
Female End

DIMENSIONS—WEIGHTS

SIZE	Dimensions										Weight		
	A		B		C		D		E		Lbs.	Kg.	
In.	mm.	In.	mm.	In.	mm.	In.	mm.	In.	mm.	In.	mm.		
1/2"	13	2.76	70	1.90	48	6.00	152	.50	13	4.15	105	.79	.36
3/4"	19	3.28	83	2.21	56	7.18	182	.75	19	5.05	128	1.62	.73
1"	25	3.59	91	2.41	61	7.34	186	1.00	25	5.36	136	2.18	.99
1 1/4"	32	4.62	117	3.05	77	10.04	255	1.25	32	6.04	169	3.64	1.65
1 1/2"	38	5.23	133	3.30	84	10.72	272	1.50	38	6.64	203	5.59	2.54
2"	50	5.63	143	3.51	89	11.05	281	2.00	50	8.65	220	8.02	3.64

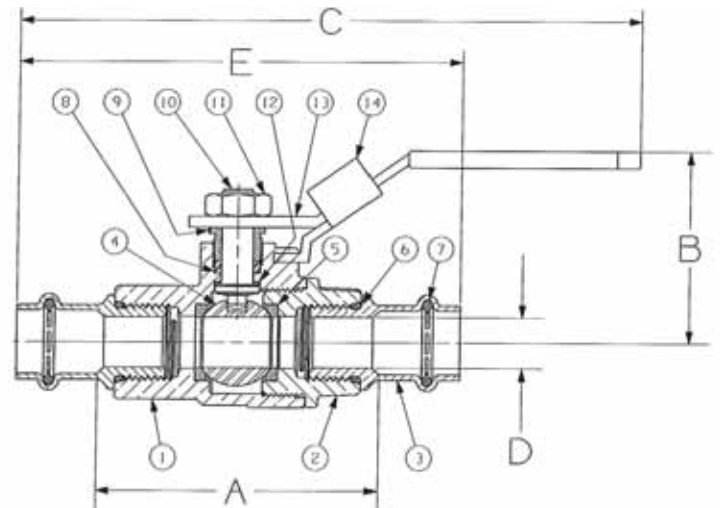

PC585-70-LL
P x P

NIBCO® Press System® ball valves are designed to meet MSS SP-110 with the exception of the end connection. Ball valves are down-rated from 600 PSI CWP to 250 PSI CWP to match the Press System®. Male and female press-to-connect ends are new technology not yet covered in the current edition of this specification.

NIBCO® Press System® Bronze Ball Valves

Two-Piece Body • Full Port • Stainless Trim • Blowout-Proof Stem • Vented Ball
• Locking Handle

250 PSI/17.2 Bar Non-Shock Cold Working Pressure
250°F Maximum Operating Temperature

CONFORMS TO MSS SP-110

MATERIAL LIST

PART	SPECIFICATION
1. Body	Bronze ASTM B584 Alloy C84400
2. Body End	Bronze ASTM B584 Alloy C84400
3. Female Adapter (2)	Bronze ASTM B61 Alloy C92200
4. Ball (vented)	Stainless Steel ASTM A276 Type 316 or ASTM A351 Type CF8M
5. Seat Ring (2)	Reinforced PTFE
6. Boss Seal O-Ring (2)	EPDM
7. O-Ring (2)	EPDM
8. Packing	PTFE
9. Pack Gland	Brass ASTM B16 Alloy C36000
10. Stem	Stainless Steel ASTM A276 Type 316
11. Handle Nut	300 Series Stainless Steel
12. Thrust Washer	Reinforced PTFE
13. Locking Handle Assembly	Zinc Plated Steel with Plastisol Coating
14. Locking Device	300 Series Stainless Steel

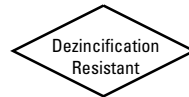

PC585-70-66-LL

Press x Press
Female End

DIMENSIONS—WEIGHTS

SIZE	Dimensions										Weight		
	A		B		C		D		E		Lbs.	Kg.	
In. mm.	In.	mm.	In.	mm.	In.	mm.	In.	mm.	In.	mm.			
1/2"	13	2.76	70	1.90	48	6.00	152	.50	13	4.15	105	.81	.37
3/4"	19	3.28	83	2.21	56	7.18	182	.75	19	5.05	128	1.61	.73
1"	25	3.59	91	2.40	61	7.34	186	1.00	25	5.36	136	2.34	1.06
1 1/4"	32	4.62	117	3.05	77	10.04	255	1.25	32	6.64	169	3.64	1.65
1 1/2"	38	5.23	133	3.30	84	10.72	272	1.50	38	8.00	203	5.59	2.54
2"	50	5.63	143	3.51	89	11.05	281	2.00	50	8.65	220	8.02	3.64

NIBCO® Press System® ball valves are designed to meet MSS SP-110 with the exception of the end connection. Ball valves are down-rated from 600 PSI CWP to 250 PSI CWP to match the Press System®. Male and female press-to-connect ends are new technology not yet covered in the current edition of this specification.

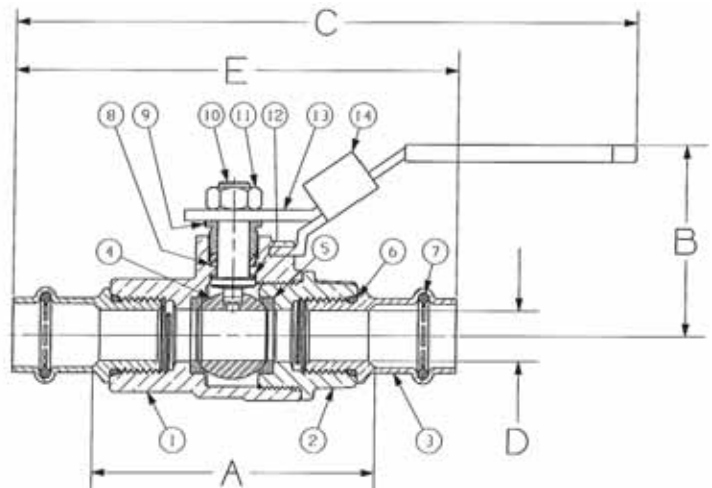

PC585-70-66-LL
P x P

NIBCO® Press System® Bronze Ball Valves

Two-Piece Body • Full Port • Bronze Trim • Blowout-Proof Stem
• 3/4" Hose Connection w/Cap and Chain

250 PSI/17.2 Bar Non-Shock Cold Working Pressure
250°F Maximum Operating Temperature

CONFORMS TO MSS SP-110

MATERIAL LIST

PART	SPECIFICATION
1. Press End Adapter	Bronze ASTM B61 Alloy C92200
2. Body	Bronze ASTM B584 Alloy C84400
3. Hose Body End	Brass ASTM B124 Alloy C37700
4. Cap	Die Cast Brass
5. O-Ring	EPDM
6. Boss seal o-ring	EPDM
7. Ball	Brass ASTM B16 Alloy C36000 or ASTM B283 Alloy C37700 (Chrome/Nickel Plated)
8. Packing	PTFE
9. Pack Gland	Brass ASTM B16 Alloy C36000
10. Stem	Silicon Bronze ASTM B371 Alloy C69300 or ASTM B371 Alloy C69430
11. Handle Nut	Zinc Plated Steel
12. Thrust Washer	Reinforced PTFE
13. Handle Assembly	Zinc Plated Steel with Plastisol Coating
14. Seat Ring (2)	Reinforced PTFE



PC585-70-HC
Press Female x Hose End

DIMENSIONS—WEIGHTS

SIZE	Dimensions				Weight						
	A	B	C	D	Lbs.	Kg.					
1/2"	13	3.06	78	1.88	48	6.09	155	.50	13	.92	.42
3/4"	19	4.47	114	2.25	57	7.36	187	.75	19	1.70	.77

NIBCO® Press System® ball valves are designed to meet MSS SP-110 with the exception of the end connection. Ball valves are down-rated from 600 PSI CWP to 250 PSI CWP to match the Press System®. Male and female press-to-connect ends are new technology not yet covered in the current edition of this specification.

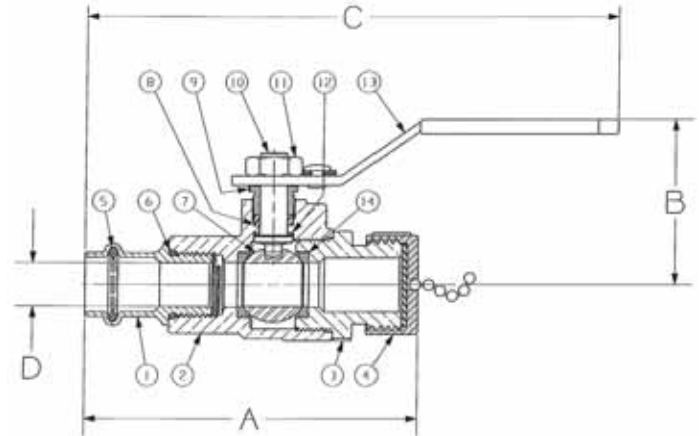

PC585-70-HC
P x Hose

NIBCO® Press System® Bronze Ball Valves

Two-Piece Body • Full Port • Stainless Trim • Blowout-Proof Stem • Vented Ball
• 3/4" Hose Connection w/Cap and Chain

250 PSI/17.2 Bar Non-Shock Cold Working Pressure
250°F Maximum Operating Temperature

CONFORMS TO MSS SP-110

MATERIAL LIST

PART	SPECIFICATION
1. Female Adapter	Bronze ASTM B61 Alloy C92200
2. Body	Bronze ASTM B584 Alloy C84400
3. Hose Body End	Brass ASTM B124 Alloy C37700
4. Cap	Die Cast Brass
5. O-Ring	EPDM
6. Boss seal o-ring	EPDM
7. Ball (vented)	Stainless Steel ASTM A276 Type 316 or ASTM A351 Type CF8M
8. Packing	PTFE
9. Pack Gland	Brass ASTM B16 Alloy C36000
10. Stem	Stainless Steel ASTM A276 Type 316
11. Handle Nut	300 Series Stainless Steel
12. Thrust Washer	Reinforced PTFE
13. Handle Assembly	Zinc Plated Steel with Plastisol Coating
14. Seat Ring (2)	Reinforced PTFE



PC585-70-66-HC
Press Female x Hose End

DIMENSIONS—WEIGHTS

SIZE	Dimensions				Weight						
	A	B	C	D	Lbs.	Kg.					
1/2"	13	2.76	70	1.88	48	6.09	155	.50	13	.92	.42
3/4"	19	3.28	83	2.25	57	7.36	187	.75	19	1.70	.77

NIBCO® Press System® ball valves are designed to meet MSS SP-110 with the exception of the end connection. Ball valves are down-rated from 250 PSI CWP to 250 PSI CWP to match the Press System®. Male and female press-to-connect ends are new technology not yet covered in the current edition of this specification.

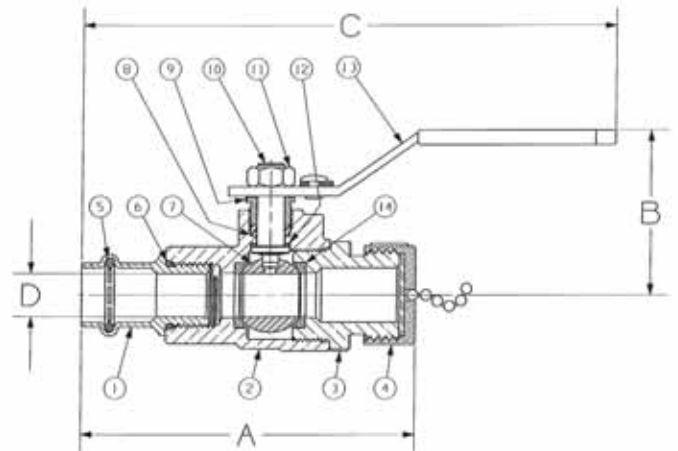

PC585-70-66-HC
P x Hose

NIBCO® Press System® Lead-Free* Bronze Ball Valves

Silicon Performance Bronze™ Two-Piece Body • Copper Ends •
Full Port • Blowout-Proof Stem • MSS SP-110 • UPC-IGC-157 •
NSF/ANSI-61-8 Commercial Hot 180°F (includes Annex F and G) and NSF/ANSI-372

Size Range: 1/2" - 2"

Pressure Rating: 250 PSI CWP

Body Design Pressure: 600 PSI CWP

Maximum Operating Temperature: 250°F

Lead-Free* markings:

Double oval in body casting, white handle and blue hang tag

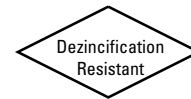
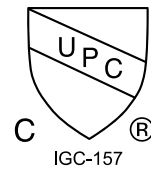

MATERIAL LIST

PART	SPECIFICATION
1. Handle Nut	Plated Steel
2. Stem	Silicon Bronze ASTM B371 Alloy C69300
3. Pack Gland	Brass ASTM B16 Alloy C36000
4. Packing, Stem	PTFE
5. Thrust Washer	Reinforced PTFE
6. Handle Assembly	Plated Steel with Plastisol Coating
7. Body End	Silicon Bronze ASTM B584 Alloy C87600
8. Seat Ring (2)	Reinforced PTFE
9. Ball	Silicon Bronze ASTM B283 Alloy C69300
10. Body	Silicon Bronze ASTM B584 Alloy C87600
11. Boss seal o-ring (2)	EPDM
12. O-Ring (2)	EPDM
13. Press End Adapter (2)	Wrot Copper ASTM B75 Alloy C12200



PC585-80-LF

Press x Press
Female End

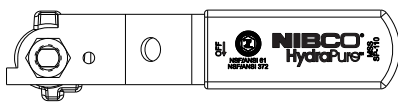

Handle Markings

DIMENSIONS—WEIGHTS

SIZE	Dimensions										Weight		
	A		B		C		D		E		Lbs.	Kg.	
In. mm.	In. mm.	In. mm.	In. mm.	In. mm.	In. mm.	In. mm.	In. mm.	In. mm.	In. mm.	In. mm.			
1/2	15	3.93	99.82	3.96	100.58	1.96	49.78	0.50	12.70	2.53	64.26	0.80	0.36
3/4	20	5.00	127.00	4.76	120.90	2.28	57.91	0.75	19.05	3.23	82.04	1.56	0.71
1	25	5.61	142.49	4.76	120.90	2.48	62.99	1.00	25.40	3.84	97.54	2.13	1.00
1¼	32	6.23	158.24	6.76	171.70	3.10	78.74	1.25	31.75	4.21	106.93	3.73	1.69
1½	40	7.56	192.02	6.76	171.70	3.32	84.33	1.50	38.10	4.79	121.67	5.53	2.51
2	50	8.40	213.36	6.76	171.70	3.56	90.42	2.00	50.80	5.36	136.14	7.95	3.61

NIBCO® Press System® ball valves are designed to meet MSS SP-110 with the exception of the end connection. Ball valves are down-rated from 600 PSI CWP to 250 PSI CWP to match the Press System®.

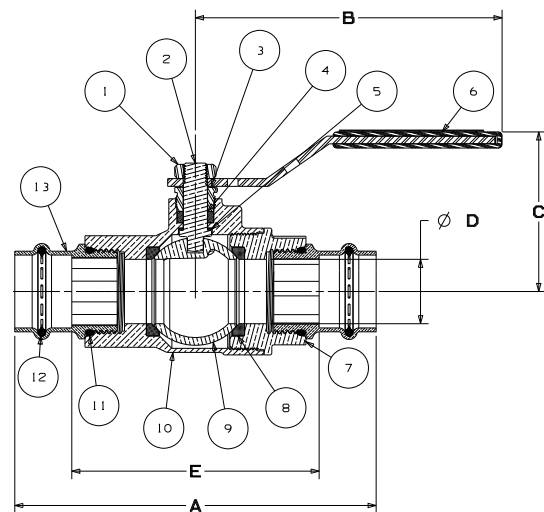

PC585-80-LF
P x P

Handle Options:

- NIB-Seal®
- Locking lever
- Memory stop
- Extended lever w/ memory stop
- Round
- Wing
- Horizontal and vertical chain

*Lead Free refers to the wetted surface of pipe, fittings and fixtures in potable water systems that have a weighted average lead content ≤ 0.25% per the Safe Drinking Water Act (Sec. 1417) amended 1-4-2011 and other equivalent state regulations.

NIBCO® Press System® Lead-Free* Bronze Ball Valves

Silicon Performance Bronze™ Two-Piece Body • Copper Ends •
Full Port • Blowout-Proof Stem • Stainless Trim • MSS SP-110 • UPC-IGC-157 •
NSF/ANSI-61-8 Commercial Hot 180°F (includes Annex F and G) and NSF/ANSI-372

Size Range: 1/2" - 2"

Pressure Rating: 250 PSI CWP

Body Design Pressure: 600 PSI CWP

Maximum Operating Temperature: 250°F

Lead-Free* markings:

Double oval in body casting, white handle and blue hang tag

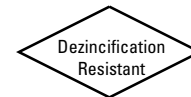
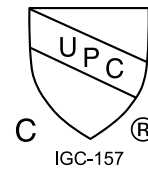

MATERIAL LIST

PART	SPECIFICATION
1. Handle Nut	Plated Steel
2. Stem	Stainless Steel ASTM A276 Type 316
3. Pack Gland	Brass ASTM B16 Alloy C36000
4. Packing, Stem	PTFE
5. Thrust Washer	Reinforced PTFE
6. Handle Assembly	Plated Steel with Plastisol Coating
7. Body End	Silicon Bronze ASTM B584 Alloy C87600
8. Seat Ring (2)	Reinforced PTFE
9. Ball (vented)	Stainless Steel ASTM A276 Type 316
10. Body	Silicon Bronze ASTM B584 Alloy C87600
11. Boss seal o-ring (2)	EPDM
12. O-Ring (2)	EPDM
13. Press End Adapter (2)	Wrot Copper ASTM B75 Alloy C12200



PC585-66-LF

Press x Press
Female End

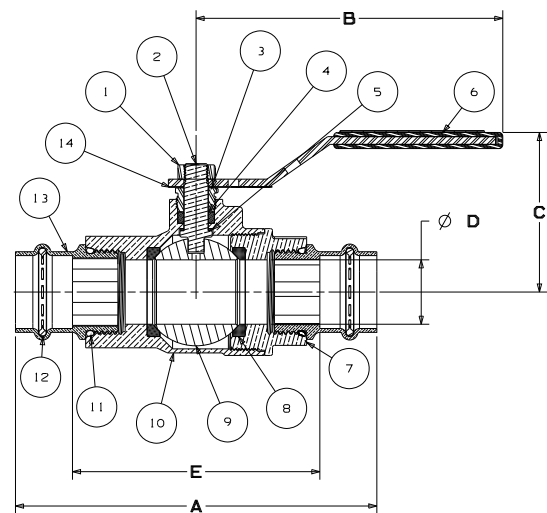

PC585-66-LF
P x P

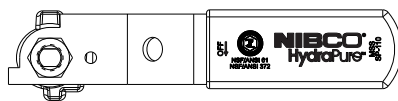

Handle Markings

DIMENSIONS—WEIGHTS

SIZE	Dimensions										Weight	
	A		B		C		D		E			
In. mm.	In. mm.	In. mm.	In. mm.	In. mm.	In. mm.	In. mm.	In. mm.	In. mm.	In. mm.	Lbs.	Kg.	
1/2	15 3.93	99.82	3.96	100.58	1.96	49.78	0.50	12.70	2.53	64.26	0.80	0.36
3/4	20 5.00	127.00	4.76	120.90	2.28	57.91	0.75	19.05	3.23	82.04	1.56	0.71
1	25 5.61	142.49	4.76	120.90	2.48	62.99	1.00	25.40	3.84	97.54	2.13	1.00
1¼	32 6.23	158.24	6.76	171.70	3.10	78.74	1.25	31.75	4.21	106.93	3.73	1.69
1½	40 7.56	192.02	6.76	171.70	3.32	84.33	1.50	38.10	4.79	121.67	5.53	2.51
2	50 8.40	213.36	6.76	171.70	3.56	90.42	2.00	50.80	5.36	136.14	7.95	3.61

NIBCO® Press System® ball valves are designed to meet MSS SP-110 with the exception of the end connection. Ball valves are down-rated from 600 PSI CWP to 250 PSI CWP to match the Press System®.

Handle Options:

- NIB-Seal®
- Locking lever
- Memory stop
- Extended lever w/ memory stop
- Round
- Wing
- Horizontal and vertical chain

*Lead Free refers to the wetted surface of pipe, fittings and fixtures in potable water systems that have a weighted average lead content ≤ 0.25% per the Safe Drinking Water Act (Sec. 1417) amended 1-4-2011 and other equivalent state regulations.

NIBCO® Press System® Brass Ball Valves

Two-Piece Body • Full Port • Brass Trim • Blowout-Proof Stem • PTFE Seats

200 PSI/41.4 Bar Non-Shock Cold Working Pressure
250°F Maximum Operating Temperature

CONFORMS TO MSS SP-110

MATERIAL LIST

PART	SPECIFICATION
1. Handle	Plated Steel with Plastisol Cover
2. Handle Nut	Plated Steel
3. Pack Gland	Brass ASTM B16 Alloy C36000
4. Packing, Stem	Virgin PTFE
5. Flat Washer	430 Stainless
6. O-Ring (Stem Seal)	Fluorocarbon (FKM)
7. Thrust Washer	Reinforced PTFE
8. Stem	$\frac{1}{2}$ " - 1" Brass ASTM B16 Alloy C36000 $1\frac{1}{4}$ " - 2" Silicon Bronze ASTM B371 Alloy 69400 or 69430
9. Body	Forged Brass ASTM B283 Alloy C37700
10. Seat Ring (2)	Virgin PTFE
11. Ball	$\frac{1}{2}$ " - $\frac{3}{4}$ " Brass ASTM B16 Alloy C36000 (Chrome/Nickel Plated) 1" - 2" Forged Brass ASTM B124 Alloy C37700 (Chrome/Nickel Plated)
12. Body End Piece	Forged Brass ASTM B283 Alloy C37700
13. Female Adapter (2)	Bronze ASTM B61 Alloy C92200
14. O-Ring (2)	EPDM



PFFP60

Press x Press
Female End

DIMENSIONS—WEIGHTS

Size	Dimensions				Weight						
	A	B	C	D	Lbs.	Kg.					
$\frac{1}{2}$	15	2.37	60	3.90	99	1.95	50	0.50	13	.54	1.19
$\frac{3}{4}$	20	3.18	81	4.66	118	2.30	58	0.75	19	1.16	2.55
1	25	3.84	98	4.66	118	2.50	64	1.00	25	1.61	3.54
$1\frac{1}{4}$	32	4.34	110	6.69	170	3.05	78	1.25	32	2.63	5.79
$1\frac{1}{2}$	40	4.88	124	6.69	170	3.23	82	1.50	38	3.69	8.12
2	50	6.04	153	6.69	170	3.55	90	2.00	51	5.76	12.68

NIBCO® Press System® ball valves are designed to meet MSS SP-110 with the exception of the end connection. Ball valves are down-rated from 600 PSI CWP to 200 PSI CWP to match the Press System®. Male and female press-to-connect ends are new technology not yet covered in the current edition of this specification.

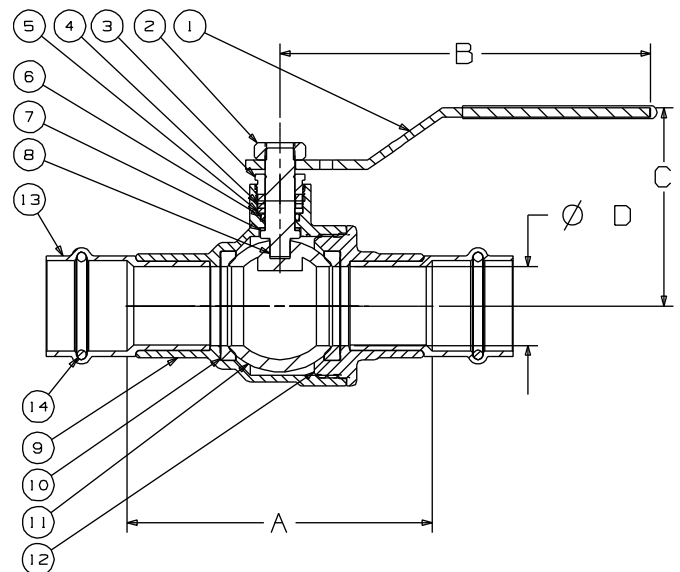

PFFP60
P x P

NIBCO® Press System® Bronze Gate Valves

Screw-in Bonnet • Rising Stem • Solid Wedge



200 PSI/13.8 Bar Non-Shock Cold Working Pressure
250°F Maximum Operating Temperature

CONFORMS TO MSS SP-80

MATERIAL LIST

PART	SPECIFICATION
1. Handwheel Nut	300 Series Stainless Steel
2. Identification Plate	Aluminum
3. Handwheel	Malleable Iron ASTM A 47
4. Stem	Silicon Bronze ASTM B 371 Alloy C69430 or ASTM B 99 Alloy C65100
5. Pack Nut	Brass ASTM B 16 Alloy C36000
6. Pack Gland	Brass ASTM B 16 Alloy C36000
7. Packing	Aramid Fibers with Graphite
8. Bonnet	Bronze ASTM B 62 Alloy C83600
9. Body Assembly	Bronze ASTM B 62 Alloy C83600
10. Wedge	Bronze ASTM B 62 Alloy C83600
11. Female Adapter (2)	Bronze ASTM B 61 Alloy C92200
12. O-Ring (2)	EPDM



PF111

Press x Press
Female End

DIMENSIONS—WEIGHTS

Size	Dimensions						Weight		
	A		B		C		Lbs.	Kg.	
In.	mm.	In.	mm.	In.	mm.	In.	mm.		
½ †	15	1.97	50	4.81	122	.50	13	.84	.38
¾	20	2.62	67	5.81	148	.75	19	1.30	.59
1	25	3.07	78	7.09	180	1.00	25	2.09	.95
1¼	32	3.36	85	8.13	206	1.25	32	2.95	1.34
1½	40	3.70	94	9.81	249	1.50	38	4.16	1.89
2	50	4.28	109	11.56	294	2.00	51	6.79	3.09

† No packing gland, packing only in this size.

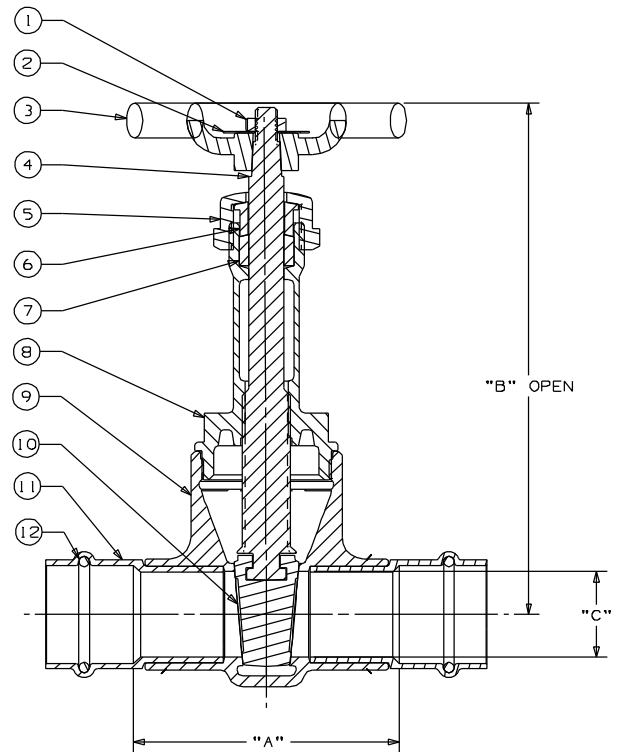

PF111
P x P

NIBCO® Press System® gate valves are designed to meet MSS SP-80 with the exception of the end connection. Male and female press-to-connect ends are new technology not yet covered in the current edition of this specification.

NIBCO® Press System® Bronze Gate Valves

Screw-in Bonnet • Non-Rising Stem • Solid Wedge

200 PSI/13.8 Bar Non-Shock Cold Working Pressure
250°F Maximum Operating Temperature

CONFORMS TO MSS SP-80

MATERIAL LIST

PART	SPECIFICATION
1. Handwheel Nut	300 Series Stainless Steel
2. Identification Plate	Aluminum
3. Handwheel	Malleable Iron ASTM A 47
4. Stem	Silicon Bronze ASTM B 371 Alloy C69430 or ASTM B 99 Alloy C65100
5. Pack Nut	Brass ASTM B 16 Alloy C36000
6. Pack Gland	Brass ASTM B 16 Alloy C36000
7. Packing	Aramid Fibers with Graphite
8. Stuffing Box	Bronze ASTM B 62 Alloy C83600
9. Bonnet	Bronze ASTM B 62 Alloy C83600
10. Body Assembly	Bronze ASTM B 62 Alloy C83600
11. Wedge	Bronze ASTM B 62 Alloy C83600
12. Female Adapter (2)	Bronze ASTM B 61 Alloy C92200
13. O-Ring (2)	EPDM

DIMENSIONS—WEIGHTS

Size	Dimensions						Weight		
	A		B		C		Lbs.	Kg.	
In.	mm.	In.	mm.	In.	mm.	In.	mm.		
½ †	15	1.97	50	3.63	92	.50	13	.78	.36
¾	20	2.62	67	3.91	99	.75	19	1.21	.55
1	25	3.07	78	4.69	119	1.00	25	1.92	.88
1¼	32	3.36	85	5.22	133	1.25	32	2.69	1.22
1½	40	3.70	94	6.25	159	1.50	38	3.91	1.78
2	50	4.28	109	7.06	179	2.00	51	6.21	2.83

†No packing gland, packing only in this size.



PF113
Press x Press
Female End

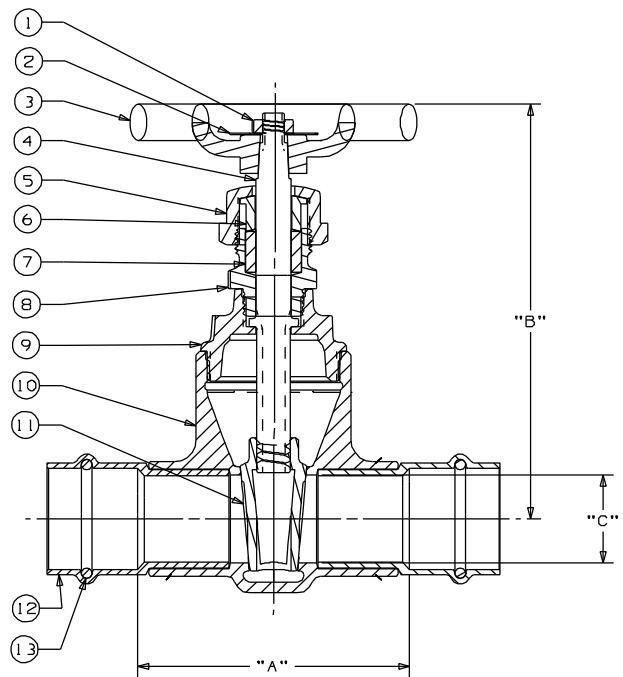

PF113
P x P

NIBCO® Press System® gate valves are designed to meet MSS SP-80 with the exception of the end connection. Male and female press-to-connect ends are new technology not yet covered in the current edition of this specification.

NIBCO® Press System® Bronze Globe Valves

Screw-in Bonnet • Integral Seat • Renewable Seat and Disc

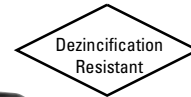

200 PSI/13.8 Bar Non-Shock Cold Working Pressure
250°F Maximum Operating Temperature

CONFORMS TO MSS SP-80

MATERIAL LIST

PART	SPECIFICATION
1. Handwheel Nut	300 Series Stainless Steel
2. Identification Plate	Aluminum
3. Handwheel	Malleable Iron ASTM A 47
4. Stem	Silicon Bronze ASTM B 371 Alloy C69430
5. Pack Gland	Brass ASTM B 16 Alloy C36000
6. Pack Nut	Brass ASTM B 16 Alloy C36000
7. Packing	Aramid Fibers with Graphite
8. Bonnet	Bronze ASTM B 62 Alloy C83600
9. Disc Holder Nut	Bronze ASTM B 62 Alloy C83600
10. Disc Holder	Bronze ASTM B 62 Alloy C83600
11. Disc	PTFE
12. Disc Washer	304 Stainless Steel
13. Disc Nut	Bronze ASTM B 98 Alloy C65100
14. Body Assembly	Bronze ASTM B62 Alloy C83600
15. Female Adapter (2)	Bronze ASTM B 61 Alloy C92200
16. O-Ring (2)	EPDM



PF211-Y

Press x Press
Female End

DIMENSIONS—WEIGHTS

Size	Dimensions						Weight			
	A		B		C		Lbs.		Kg.	
In.	mm.	In.	mm.	In.	mm.	In.	mm.	Lbs.	Kg.	
*½†	15	2.91	74	3.38	86	.50	13	1.07	.48	
¾	20	3.99	101	4.88	124	.75	19	2.04	.93	
1	25	4.88	124	5.69	145	1.00	25	3.13	1.42	
1¼	32	5.23	133	6.13	156	1.25	32	4.00	1.82	
1½	40	6.01	153	7.38	187	1.50	38	6.44	2.93	
2	50	7.41	188	7.94	202	2.00	51	10.16	4.62	

† No packing gland, packing only in this size.

* Stem and disc (or disc holder) are integral.

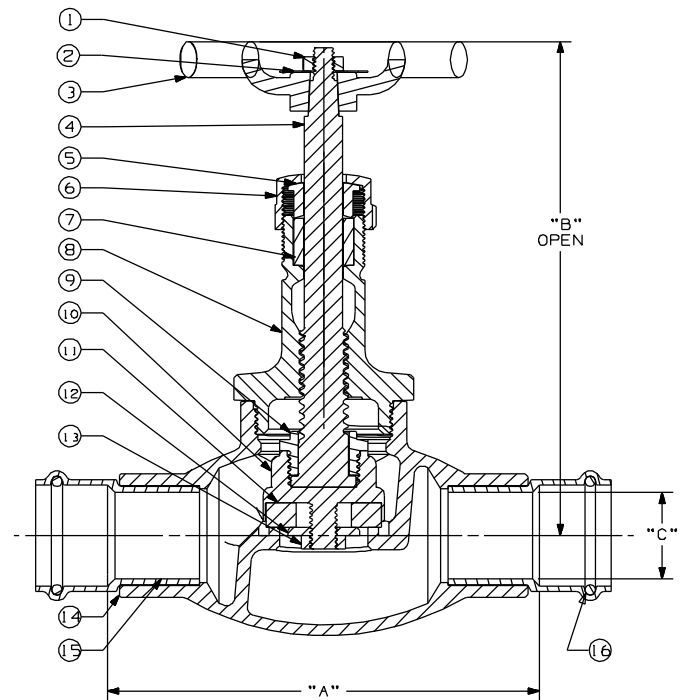

PF211-Y
P x P

NIBCO® Press System® globe valves are designed to meet MSS SP-80 with the exception of the end connection. Male and female press-to-connect ends are new technology not yet covered in the current edition of this specification.

NIBCO® Press System® Bronze Angle Valves

Screw-in Bonnet • Integral Seat • Renewable Seat and Disc

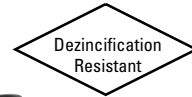

200 PSI/13.8 Bar Non-Shock Cold Working Pressure
250°F Maximum Operating Temperature

CONFORMS TO MSS SP-80

MATERIAL LIST

PART	SPECIFICATION
1. Handwheel Nut	300 Series Stainless Steel
2. Identification Plate	Aluminum
3. Handwheel	Malleable Iron ASTM A 47
4. Stem	Silicon Bronze ASTM B 371 Alloy C69430
5. Pack Gland	Brass ASTM B 16 Alloy C36000
6. Pack Nut	Brass ASTM B 16 Alloy C36000
7. Packing	Aramid Fibers with Graphite
8. Bonnet	Bronze ASTM B 62 Alloy C83600
9. Disc Holder Nut	Bronze ASTM B 62 Alloy C83600
10. Disc Holder	Bronze ASTM B 62 Alloy C83600
11. Disc	PTFE
12. Disc Washer	304 Stainless Steel
13. Disc Nut	Silicon Bronze ASTM B 96 Alloy C65100
14. Body	Bronze ASTM B 62 Alloy C83600
15. Female Adapter (2)	Bronze ASTM B 61 Alloy C92200
16. O-Ring (2)	EPDM



PF311-Y
Press x Press
Female End

DIMENSIONS—WEIGHTS

Size	Dimensions				Weight				
	B		H		J				
In.	mm.	In.	mm.	In.	mm.	In.	mm.	Lbs.	Kg.
*1/2†	15	3.50	89	1.49	38	1.49	38	1.07	.48
3/4	20	4.94	126	2.00	51	2.00	51	1.94	.88
1	25	5.75	146	2.48	63	2.48	63	3.12	1.42
1 1/4	32	6.13	156	2.59	66	2.59	66	4.21	1.92
1 1/2	40	7.25	179	2.98	76	2.98	76	5.44	2.47
2	50	8.13	206	3.64	93	3.64	93	9.98	4.54

† No packing gland, packing only in this size.

* Stem and Disc or Disc Holder are integral.

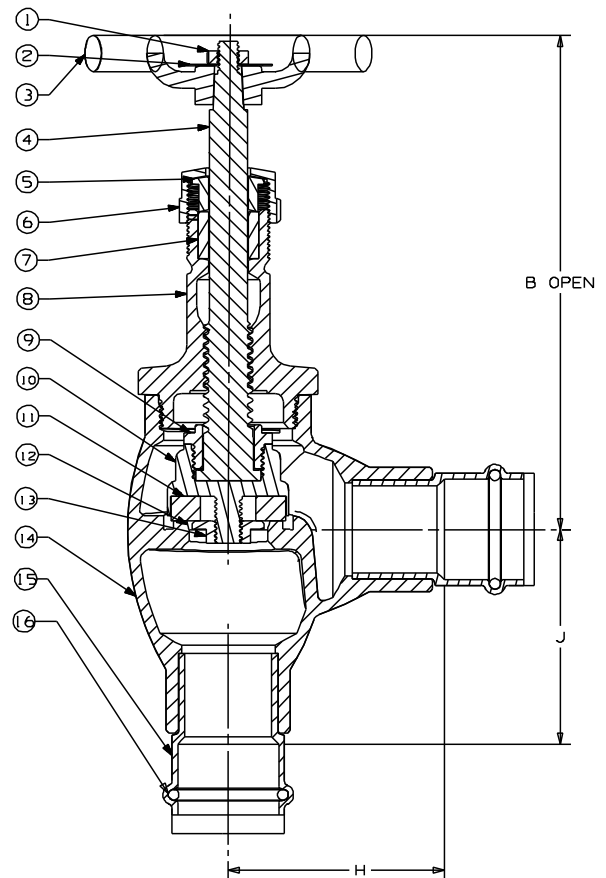

PF311-Y
P x P

NIBCO® Press System® angle valves are designed to meet MSS SP-80 with the exception of the end connection. Male and female press-to-connect ends are new technology not yet covered in the current edition of this specification.

NIBCO® Press System® Bronze Check Valves

Horizontal Swing • Regrinding Type • Y-Pattern • Renewable Seat and Disc

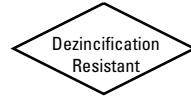

200 PSI/13.8 Bar Non-Shock Cold Working Pressure
250°F Maximum Operating Temperature

CONFORMS TO MSS SP-80

MATERIAL LIST

PART	SPECIFICATION
1. Bonnet	Bronze ASTM B 62 Alloy C83600
2. Body	Bronze ASTM B 62 Alloy C83600
3. Hinge Pin	Bronze ASTM B 140 Alloy C31400
4. Disc Hanger	Bronze ASTM B 62 Alloy C83600 or 304 SS 1/2" and 3/4" sizes only
5. Hanger Nut	Brass ASTM B 16 Alloy C36000
6. Disc Holder	Bronze ASTM B 62 Alloy C83600
7. Seat Disc	PTFE
8. Seat Disc Nut	Brass ASTM B 16 Alloy C36000
9. Hinge Pin Plug	Bronze ASTM B 140 Alloy C32000 (not shown)
*10. Seat Disc Washer	ASTM B 98 Alloy C65500 or ASTM B 103
11. Female Adapter (2)	Bronze ASTM B 61 Alloy C92200
12. O-Ring (2)	EPDM

* Sizes 3/4" thru 2" only.



PF413-Y

Press x Press
Female End

DIMENSIONS—WEIGHTS

Size	Dimensions				Weight		
	A		B		Lbs.	Kg.	
In.	mm.	In.	mm.	In.	mm.		
1/2	15	2.72	69	1.54	39	.58	.26
3/4	20	3.62	92	1.83	46	.96	.44
1	25	4.32	110	2.21	56	1.51	.69
1 1/4	32	4.92	125	2.69	68	2.29	1.04
1 1/2	40	5.58	142	2.94	75	3.30	1.50
2	50	6.72	171	3.61	92	5.45	2.48

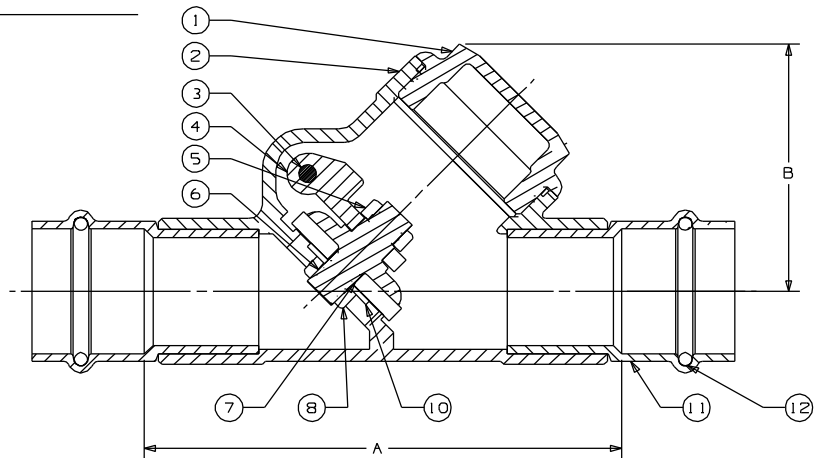

PF413-Y
P x P

NIBCO® Press System® check valves are designed to meet MSS SP-80 with the exception of the end connection. Male and female press-to-connect ends are new technology not yet covered in the current edition of this specification.

WARNING — Do not use for Reciprocating Air Compressor Service

NIBCO check valves may be installed in both horizontal and vertical lines with upward flow or in any intermediate position. They will operate satisfactorily in a declining plane (no more than 15°).

NIBCO® Press System® Bronze In-line Lift Check Valves

In-line Lift Type • Resilient Discs • Spring Actuated

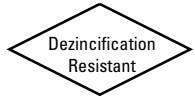

200 PSI/17.2 Bar Non-Shock Cold Working Pressure
250°F Maximum Operating Temperature

MATERIAL LIST

PART	SPECIFICATION
1. Body	Bronze ASTM B584 Alloy C84400
2. Stem	Stainless Steel ASTM A582 Alloy C30300
3. Spring	316 Stainless Steel
4. Disc Holder	Stainless Steel Type 301
5. Disc	PTFE
6. Seat Screw	Stainless Steel ASTM A276 Alloy S43000
7. Body End	Bronze ASTM B584 Alloy C84400
8. Adapter (2)	Bronze ASTM B61 Alloy C92200
9. O-Ring (2)	EPDM



PF480-Y
Press x Press
Female End

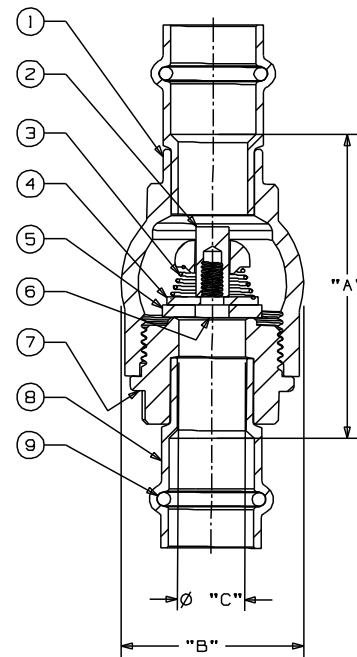

PF480-Y (PTFE Disc)
P x P

DIMENSIONS—WEIGHTS

Size	Dimensions								Weight		
	A		B		C		Lbs.	Kg.			
In.	mm.	In.	mm.	In.	mm.	In.	mm.				
½	15	2.41	61	1.38	35	.50	13	0.52	0.24		
¾	20	3.05	77	1.63	41	.75	19	0.75	0.34		
1	25	3.56	90	2.00	51	1.00	25	1.18	0.54		
1¼	32	3.86	98	2.38	60	1.25	32	1.72	0.78		
1½	40	4.45	113	2.75	70	1.50	38	2.49	1.13		
2	50	5.28	134	3.38	86	2.00	51	3.96	1.80		

NIBCO® Press System® check valves may be installed in both horizontal and vertical lines with upward flow or in any intermediate position.

WARNING - Do Not Use for reciprocating air compressor service.

NOTE: 0.5 PSI pressure required to open spring.

NOTE: Check valves are down-rated from 250 PSI CWP to 200 PSI CWP to match the Press System.

NIBCO® Press System® Butterfly Valves

Ductile Iron Body • Extended Neck • Geometric Drive
Molded-in Seat Liner • Lug Style with Press x Press Female Ends

Sizes 2 1/2" through 4"

200 PSI/13.8 Bar Non-Shock Cold Working Pressure
250°F Maximum Operating Temperature

CONFORMS TO MSS-SP67 • MSS-SP25 • API-609

MATERIAL LIST

PART	SPECIFICATION
1. Stem	Stainless Steel ASTM A 582 Type 416
2. Collar Bushing	Brass ASTM B 124
3. Stem Seal	EPDM Rubber
4. Body Seal	EPDM Rubber
5. Nameplate	Aluminum
6. Upper Bushing	Wrot Copper ASTM B 75 Alloy C12200
7. Liner	EPDM Rubber
8. Disc	Alum. Brz. ASTM B 148 Alloy 954/955
9. Lower Bushing	Wrot Copper ASTM B 75 Alloy C12200
10. Body Lug	Ductile Iron ASTM A 536
11. Flange Body (2)	Carbon Steel
12. Flange Gasket (2)	EPDM
13. Flange Press Ends (2)	Wrot Copper ASTM B 75 Alloy C12200
14. O-Ring (2)	EPDM
15. Cap Screws	Carbon Steel



PFD2000

Lug Style
EPDM Liner
and Aluminum
Bronze Disc
Press x Press
Female End

Available with lock lever handle or gear operator.

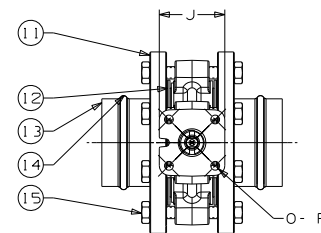
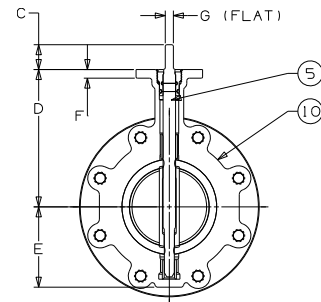
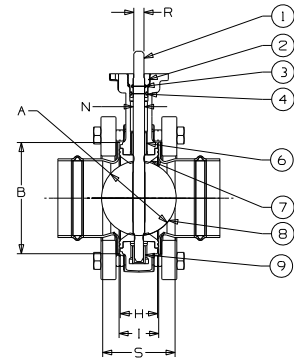

DIMENSIONS — WEIGHTS

Size	DIMENSIONS						G Flat	Metal H	Rubber I	
	A	B	C	D	E	F				
2 1/2	65	2.90	4.69	1.25	5.88	3.27	.38	.370	1.812	1.938
3	80	3.15	5.12	1.25	6.12	3.40	.38	.370	1.812	1.938
4	100	4.09	6.12	1.25	6.88	4.00	.38	.403	2.062	2.188

Size	J Square	N Dia.	O B.C.	P Dia.	R Dia.	S No.	Lug Length	Total Weight		
								Lbs.	Kg.	
2 1/2	65	3.25	.562	3.25	.437	.500	3.13	Refer to page 47 for bolt lengths	24.00	10.88
3	80	3.25	.562	3.25	.437	.500	3.44		26.00	11.78
4	100	3.25	.625	3.25	.437	.562	4.00		38.00	17.23

NIBCO® Press System® butterfly valves are designed to meet MSS SP-67 with the exception of the end connection. Male and female press-to-connect ends are new technology not yet covered in the current edition of this specification.

NOT RECOMMENDED FOR STEAM SERVICE

NIBCO® Press System® Bronze Ball Valves

Two-Piece Body • Full Port • Bronze Trim • Blowout-Proof Stem



600 PSI/41.4 Bar Non-Shock Cold Working Pressure

250°F Maximum Operating Temperature

CONFORMS TO MSS SP-110

MATERIAL LIST

PART	SPECIFICATION
1. Handle Nut	Zinc Plated Steel
2. Handle Assembly	Zinc Plated Steel with Plastisol Cover
3. Pack Gland	Brass ASTM B 16 Alloy C36000
4. Packing	PTFE
5. Stem	Silicon Bronze ASTM B 371 Alloy C69430
6. Thrust Washer	RPTFE
7. Ball	Brass ASTM B 16 Alloy C36000 or ASTM B 124 Alloy C37700 (Chrome/Nickle Plated)
8. Seat Ring (2)	RPTFE
9. Body	Bronze ASTM B 584 Alloy C84400
10. Body End Piece	Bronze ASTM B 584 Alloy C84400
11. Stub Out (2)	Type "L" Copper Tube



PS585-70

Press x Press
Male End

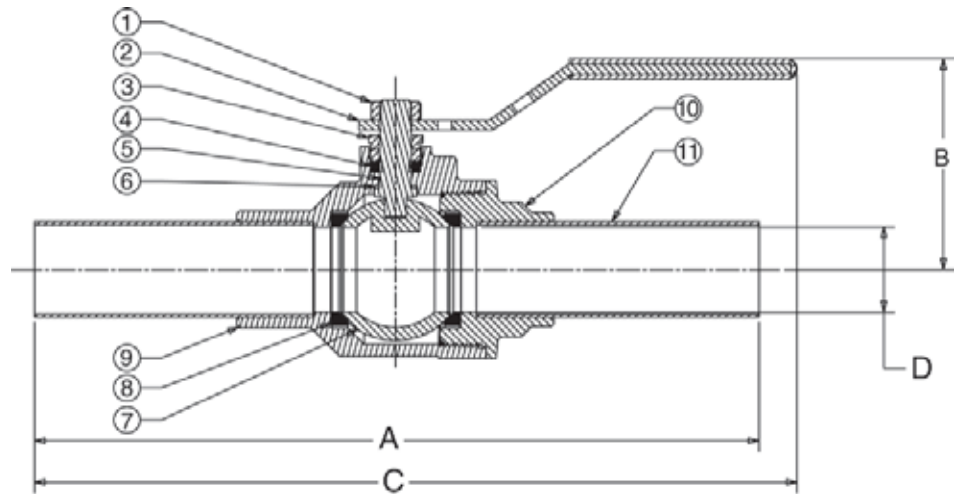

PS585-70
P x P

DIMENSIONS—WEIGHTS

Size	Dimensions								Weight	
	A		B		C		D		Lbs.	Kg.
In. mm.	In. mm.	In. mm.	In. mm.	In. mm.	In. mm.	In. mm.	In. mm.	Lbs.	Kg.	
½	15 6.56	167 1.88	48 7.25	184 2.50	13 .73	.99				
¾	20 7.25	184 2.25	57 8.25	210 2.75	19 1.50	.68				
1	25 7.75	197 2.38	60 8.63	219 3.00	25 2.05	.93				
1¼	32 9.06	230 3.00	76 9.19	233 1.25	32 3.64	1.65				
1½	40 9.99	254 3.16	80 11.69	297 1.50	38 5.73	2.60				
2	50 10.72	272 3.50	89 12.06	306 2.00	51 8.11	3.68				

NIBCO® Press System® ball valves are designed to meet MSS SP-110 with the exception of the end connection. Ball valves are down-rated from 600 PSI CWP to 200 PSI CWP to match the Press System®. Male and female press-to-connect ends are new technology not yet covered in the current edition of this specification.

NIBCO® Press System® Bronze Ball Valves

Two-Piece Body • Full Port • Stainless Trim • Blowout-Proof Stem • Vented Ball

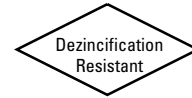

600 PSI/41.4 Bar Non-Shock Cold Working Pressure
250°F Maximum Operating Temperature
Nominal sizes 1/2" through 1" are UL certified to NSF/ANSI 61
CONFORMS TO MSS SP-110



PS585-70-66

Press x Press
Male End

MATERIAL LIST	
PART	SPECIFICATION
1. Handle Nut	Zinc Plated Steel
2. Handle Assembly	Zinc Plated Steel with Plastisol Cover
3. Pack Gland	Brass ASTM B 16 Alloy C36000
4. Packing	PTFE
5. Stem	ASTM A 276 Alloy S31600 Stainless Steel
6. Thrust Washer	RPTFE
7. Ball	ASTM A 276 Alloy S31600 Stainless Steel
8. Seat Ring (2)	RPTFE
9. Body	Bronze ASTM B 584 Alloy C84400
10. Body End Piece	Bronze ASTM B 584 Alloy C84400
11. Stub Out (2)	Type "L" Copper Tube

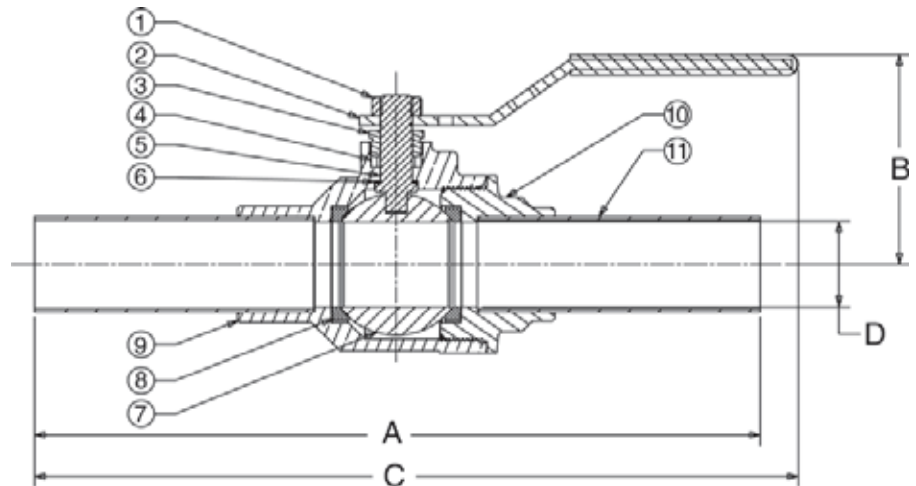

PS585-70-66
P x P

DIMENSIONS—WEIGHTS

Size	Dimensions				Weight						
	A	B	C	D	Lbs.	Kg.					
1/2	15	6.56	167	1.88	48	7.25	184	.50	13	.73	.33
3/4	20	7.25	184	2.25	57	8.25	210	.75	19	1.50	.68
1	25	7.75	197	2.38	60	8.63	219	1.00	25	2.05	.93
1 1/4	32	9.06	230	3.00	76	9.19	233	1.25	32	3.86	1.75
1 1/2	40	9.99	254	3.16	80	11.69	297	1.50	38	5.79	2.63
2	50	10.72	272	3.50	89	12.06	306	2.00	51	8.84	4.00

NIBCO® Press System® ball valves are designed to meet MSS SP-110 with the exception of the end connection. Ball valves are down-rated from 600 PSI CWP to 200 PSI CWP to match the Press System®. Male and female press-to-connect ends are new technology not yet covered in the current edition of this specification.

NIBCO® Press System® Bronze Ball Valves

Two-Piece Body • Full Port • Bronze Trim • ¾" Hose Connection
with Cap and Chain • Blowout-Proof Stem

600 PSI/41.4 Bar Non-Shock Cold Working Pressure
250°F Maximum Operating Temperature

CONFORMS TO MSS SP-110

MATERIAL LIST

PART	SPECIFICATION
1. Handle Nut	Zinc Plated Steel
2. Handle	Zinc Plated Steel
3. Pack Gland	Brass ASTM B 16 Alloy C36000
4. Packing	PTFE
5. Thrust Washer	RPTFE
6. Stem	Silicon Bronze ASTM B 371 Alloy C69430
7. Ball	Brass ASTM B 16 Alloy C36000 or ASTM B 124 Alloy C37700 (Chrome/Nickle Plated)
8. Seat Rings	Reinforced PTFE
9. Body Assembly	Bronze ASTM B 584 Alloy C84400
10. Hose Body End	Brass ASTM B 124 Alloy C37700
11. Cap	Die Cast Brass
12. Gasket	Rubber
13. Chain	Brass
14. Stub Out	Type "L" Copper Tube

Cap is for hose end thread protection only. Not to be used for pressure containing purposes.



PS585-70-HC
Press Male x Hose End

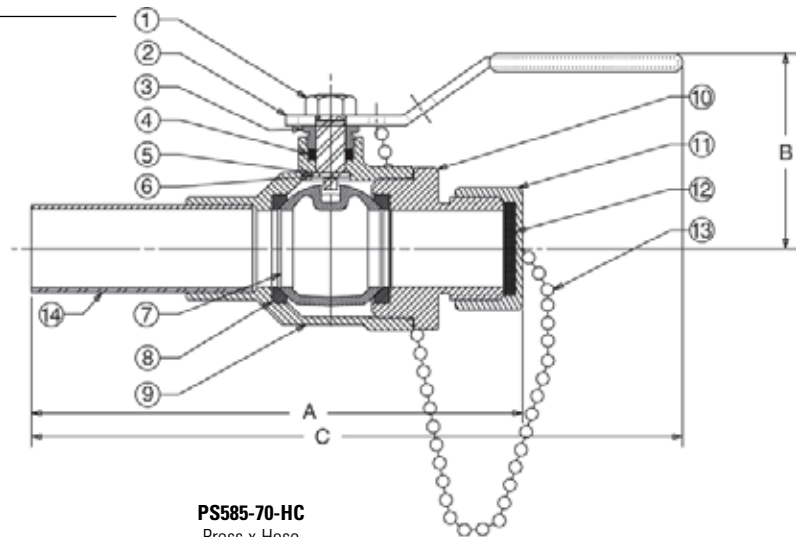

PS585-70-HC
Press x Hose

DIMENSIONS—WEIGHTS

Size	Dimensions						Weight		
	A		B		C		Lbs.	Kg.	
In.	mm.	In.	mm.	In.	mm.	In.	mm.		
½	15	4.90	124	1.88	48	7.19	183	.81	.37
¾	20	5.47	139	2.25	57	8.25	210	1.54	.70

NIBCO® Press System® ball valves are designed to meet MSS SP-110 with the exception of the end connection. Ball valves are down-rated from 600 PSI CWP to 200 PSI CWP to match the Press System®. Male and female press-to-connect ends are new technology not yet covered in the current edition of this specification.

Class 125 Bronze Y-Strainers

Screw-in Cap • Tapped Cap w/ Blow-off Plug or Solid Cap
• 20 Mesh SS Screen or SS Perforated Screen

200 PSI/13.8 Bar Non-Shock Cold Working Pressure
250° F Maximum Operating Temperature

CONFORMS TO MSS SP-110

MATERIAL LIST

PART	SPECIFICATION
1. Body	Bronze ASTM B584 Alloy C84400
2. Cap	Bronze ASTM B62 Alloy C83600
3. Gasket	PTFE
4. Screen	ASTM E2016 20 Mesh - 304 Stainless Steel or ASTM E674 Perforated - 304 Stainless Steel
5. Plug	Brass ASTM B16 Alloy C36000 or Bronze ASTM B584 Alloy C84400
6. Female Adapter (2)	Bronze ASTM B61 Alloy C92200
7. O-Ring (2)	EPDM

END CONNECTION	SCREEN	CAP
PF- Female Press	221 - 20 Mesh (STD.)	A - Tapped Cap w/Plug (STD.)
PF- Female Press	222 - Perforated	B - Solid Cap

DIMENSIONS—WEIGHTS—QUANTITIES

Dimensions									
Size		A		C		D	Weight		
In.	mm.	In.	mm.	In.	mm.	Threads	Lbs.	Kg.	
½	15	2.96	75	1.79	45	1/4 NPT	0.66	0.30	
¾	20	3.94	100	2.14	54	3/8 NPT	1.21	0.55	
1	25	4.66	118	2.79	71	3/8 NPT	1.88	0.86	
1¼	32	5.47	139	3.23	82	3/4 NPT	3.10	1.41	
1½	40	6.05	154	3.61	92	3/4 NPT	4.64	2.10	
2	50	7.40	188	4.99	127	1 NPT	7.48	3.39	

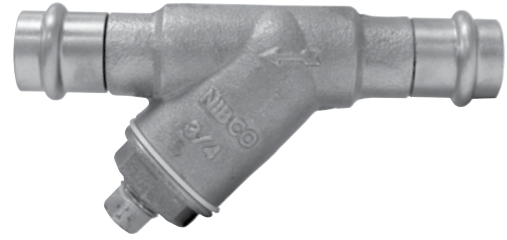
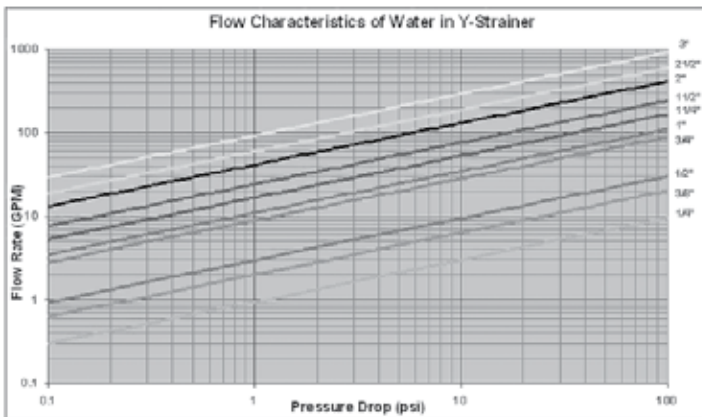

PF221/222-A

Press x Press
Female End

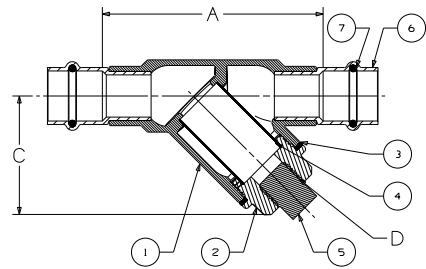

PF221/222-A

P x P

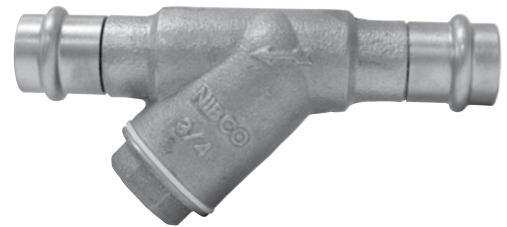

PF221/222-B

Press x Press
Female End

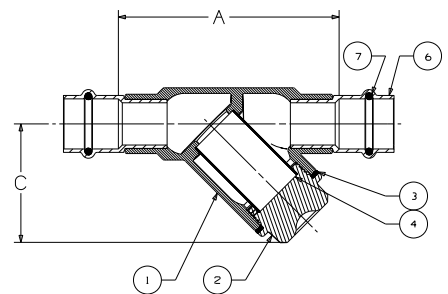

PF221/222-B

P x P

NIBCO® Press System® Ball Valve Handle Options

A wide variety of handles are available to fulfill safety and operation requirements in various processing and manufacturing industries. The lever handle with plastic cover is standard. Other handle options are shown. Stainless steel lever handles are available, as an option, also with plastic covers. If an optional handle is desired, please indicate which one when ordering. Many of these options are field assembly only.

 <p>CS Standard Lever Handle</p>	 <p>CS Extended Lever Handle with Memory Stop</p>	 <p>NIB-SEAL® Handle</p>
 <p>CS Locking Lever Handle</p>	 <p>CS Round Handle</p>	 <p>Vertical Chain Lever</p>
 <p>SS Standard Lever Handle</p>	 <p>CS Extended Round Handle</p>	 <p>Horizontal Chain Lever</p>
 <p>SS Locking Lever Handle</p>	 <p>CS Wing Handle</p>	 <p>Memory Stop Kit</p>
 <p>CS Extended Lever Handle</p>		

NIBCO® Press System® Bronze Ball Valves

NIB-SEAL® Technical Data

NIBCO® bronze ball valves installed with NIB-SEAL® insulated handles are the only approach that keeps your insulated piping system completely intact.

The revolutionary NIB-SEAL® bronze ball valve stops condensate cold. Its unique thermal barrier design keeps moisture from infiltrating your insulated system while preventing thermal energy loss through exposed metal handles.

Designed for new installations or retrofitting existing systems, NIB-SEAL bronze ball valves offer a wide range of advantages for typical commercial HVAC systems as well as industrial applications where insulated piping is desirable.

- Protective sleeve provides a stationary surface to affix the insulation, allowing operation and maintenance of the valve without destroying the integrity of the insulated system.
- High-strength cylindrical handle design features easy access to standard adjustable memory stop for system balancing. The valve packing is also readily accessible for routine maintenance.
- Cap and insulating plug provide a vapor seal to prevent exchange of air to maximize the efficiency of your insulated piping system.
- Position indicators allow at-a-glance determination of whether valve is in open or closed position.
- Pre-formed hole allows for convenient tagging.

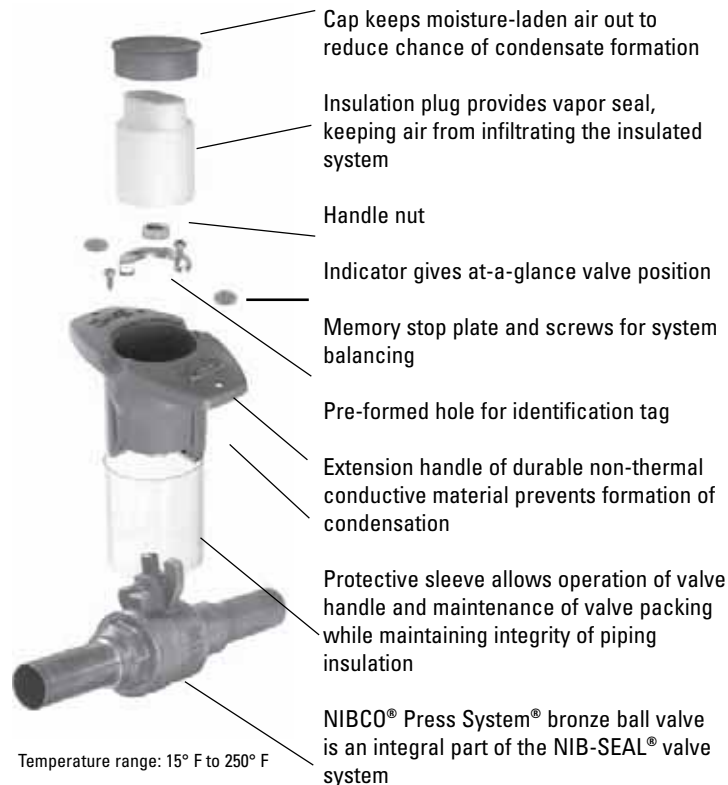

US PATENT 5,236,006

Butterfly Valve Options and Accessories

Lever-Lock Operator (Standard) PFD2000

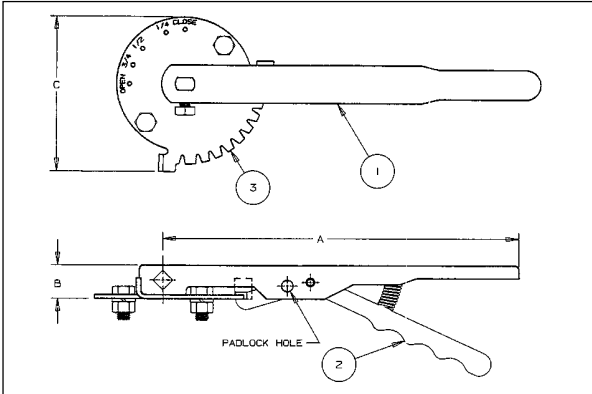

The lever-lock handle and throttling plate provide throttling notches every 10° for excellent manual control in balancing up to 90° or shut off service. The valve may be padlocked in any one of the positions including opened or closed by virtue of a locking hole located in the handle and lever.

Position-Lock Operator (Optional) PFD2000

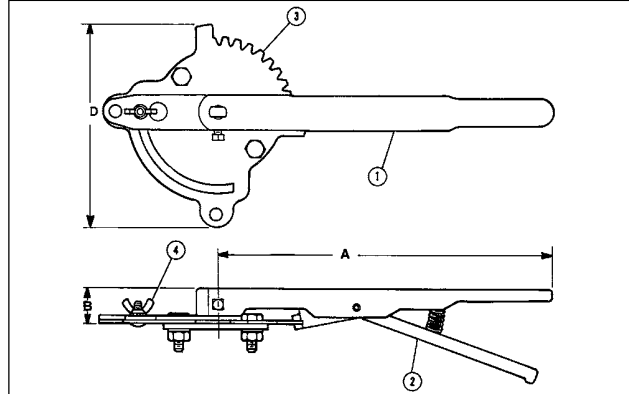

The position-lock can be used to set the valve in any position or as a memory stop so the valve may be reopened to the previous position. The valve may be padlocked in full open or full closed position.

Ordering: Sold as a field retrofitable kit only.

MATERIAL LIST

PART	SPECIFICATION
1. Handle	Polymer Coated Iron
2. Lever-Lock	Zinc Plated Steel
3. Throttle Plate	Zinc Plated Steel

DIMENSIONS AND TORQUE OUTPUT

PFD Lever Size	Throttle Plate (STD)	Throttle Plate/Infinite Pos. Kit	Dimensions				Torque Rated Output in Inch-Pounds		
			A	B	C	D	At 60 pounds Pull	At 100 pounds Pull	
2½"-3"	T115107PP	T115138PP	T114841FG	10½	1	4¾	6¾/16	540 In-Lbs.	900 In-Lbs.
4	T115108PP	T115138PP	T114842FG	10½	1	4¾	6¾/16	540 In-Lbs.	900 In-Lbs.

Gear Operator options and accessories (2 1/2" through 4" 2000 series only)

2" Square Operating Nut

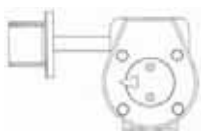

Memory Stop



Flag Indicator

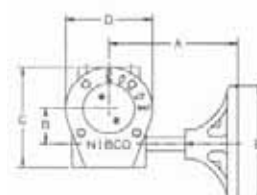

Consult factory for: Square Operating Nut, Memory Stop and Flag Indicator

2 1/2"-4"

Cast Iron Gear Operator

The NIBCO® butterfly valve can be provided with heavy-duty operator and indicator. Recommended for valves 8" and larger, for trouble-free operation in all moisture and weather conditions (not submersible). Operator is a self-locking worm gear type. Equipped with adjustable stops at open and shut positions. Ordering: Specify by adding (-5) to Fig. No., i.e., PFD2000-5. Babbit Sprocket may be added to handwheel. See below for sizing information. Available options: Memory Stop Gear Operator Kit, 2" Square Operating Nut, Flag Indicator and Handwheel for GO.

PFD VALVE	GEAR OPERATOR NUMBER	RATIO	GEAR OP WEIGHT	DIMENSIONS (INCHES)						GEAR OPERATOR ACCESSORIES & REPLACEMENT PARTS					
				A	B	C	D	E	F	STEM ADAPTER BUSHING	SPROCKET RIM MODEL	SQUARE OPERATING NUT	FLAG INDICATOR	MEMORY STOP KIT	REPLACEMENT HANDWHEEL
2½ - 3	T117118PP	24:1	10	7.64	1.77	5.04	4.24	5.91	2.79	T046653PP	#1½	T117792FC	T116682PP	T026196PP	T117122PP
4	T117118PP	24:1	10	7.64	1.77	5.04	4.24	5.91	2.79	T046654PP	#1½	T117792FC	T116682PP	T026196PP	T117122PP

Notes - 1. Stem adapter bushing must be ordered separately when needed for smaller size valves.

2. All other accessories must be ordered separately. (Sprocket rim, square operator nut, flag indicator & memory stop kit.)

3. Gear operator comes with handwheel.

Butterfly Valve Technical Information

Valve Installation Procedure

Always position the connecting pipe flanges accurately in the line, allowing sufficient space between the flanges for the valve. Make sure the pipe flange faces are clean of any foreign material such as scale, metal shavings or welding slag. Valves should be installed with the disc in the closed position to prevent damage to sealing surfaces.

- Carefully insert the valves between the pipe flanges. Do not apply any lubricants to the seat faces as this may damage them.
- Line up, center and secure the valve between flanges using desired bolts or studs as listed in Table 4.
Do not tighten bolts at this time.
- Carefully open the valve to assure free unobstructed disc movement. Disc interference may result when valves are installed in pipelines having smaller than normal inside diameters, such as heavy wall pipe, plastic-lined pipe, as-cast flanges or reducing flanges. Interference can also occur when connecting directly to a swing check or silent check. Suitable corrective measures must be taken to remove these obstructions, such as taper boring the pipe or installing a spacer or spool piece.
- After proper operation is verified, tighten the bolts using a cross-over pattern (Fig. 1) to the minimum recommended bolt torques listed in Table 3.
- Pressurize piping to valve and inspect for leakage. If leakage is observed, tighten bolts using cross-over pattern, increasing torque until leak stops.
DO NOT EXCEED MAXIMUM TORQUES LISTED IN TABLE 3.
- Recommended torques are made without warranty. Installer must verify proper strength bolts for application. Bolts shall be clean and un-lubricated.

Caution

- Class 250 cast iron and Class 300 steel flanges **can not** be used on these valves.
- Rubber faced or mechanical flanges are **not** recommended.
- This valve is **not recommended** for steam service.
- Valves should **not** be assembled to the flanges and then welded into the piping system.
- Do not install EPDM liner in compressed air lines.

Table 3 Recommended Bolt Tightening Torques

Flange Size	Bolt Size	Minimum Bolt Torque (ft.●lbs.)	Maximum Bolt Torque (ft.●lbs.)
2 1/2" - 4"	5/8"	20	70

Table 4 Recommended Bolt Lengths

VALVE SIZE 1000/2000/3000 SERIES ONLY	TOTAL VALVE BODY WIDTH	ANSI B16.1 CLASS 125 CAST IRON FLANGE THICKNESS	ANSI B16.5 CLASS 150 STEEL FLANGE THICKNESS	ANSI B16.47 (SERIES A) CLASS 150 STEEL MSS SP-44 FLANGE THICKNESS	ANSI B16.47 (SERIES B) CLASS 150 STEEL WELD NECK FLANGE THICKNESS	ANSI B16.47 (SERIES B) CLASS 150 STEEL BLIND STYLE FLANGE THICKNESS	RECOMMENDED CAP SCREW LENGTH (LUGGED VALVES) (C)	TOTAL QUANTITY CAP SCREWS/BOLTS (TO MOUNT 2 FLANGES)	CAP SCREW SIZE
2 1/2"	1.81	0.69	—	—	—	—	1.50	8/4	5/8-11 UNC
		—	0.88	—	—	—	1.75	8/4	
3"	1.81	0.75	—	—	—	—	1.50	8/4	5/8-11 UNC
		—	0.94	—	—	—	1.75	8/4	
4"	2.06	0.94	0.94	—	—	—	1.75	16/8	5/8-11 UNC

Bolt Tightening
Cross Over Pattern

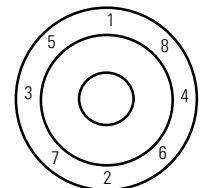
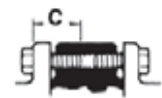

Fig. 1

Suggested
Bolting Method



LUG STYLE

Resilient Liner Materials

EPDM – EPDM is a terpolymer elastomer made from ethylene-propylene diene monomer. EPDM has good abrasion and tear resistance and offers excellent chemical resistance to a variety of acids and alkalines. It is susceptible to attack by oils and is not recommended for applications involving petroleum oils, strong acids or strong alkalines. EPDM should not be used on compressed air lines. It has exceptionally good weather aging and ozone resistance. It is fairly good in ketones and alcohols.

Liner Temperature Ratings

Liner Material	Temperature
EPDM**	-20°F to + 250°F

** EPDM is rated at 250°F intermittent service and 225°F continuous service.

Proprietary compound formulas are used for each of the elastomers to provide the right combination of seat compression, abrasion resistance and chemical resistance to match your application. Elastomeric seat materials are not suitable for steam service.

NIBCO[®] pres@system[®]



NIBCO® Press System® Tools

PC-280

1/2" through 4"



MATERIAL LIST

MODEL NO.	DESCRIPTION	LBS.
PC-280	Pressing Tool with 2 - 18V, 3.0 Ah Lithium-ion batteries, 110V battery charger & case	25.40
PC-10S	1/2" Standard Pressing Jaw (for PC-100 or PC-280)	4.14
PC-11S	3/4" Standard Pressing Jaw (for PC-100 or PC-280)	4.18
PC-12S	1" Standard Pressing Jaw (for PC-100 or PC-280)	4.52
PC-13S	1 1/4" Standard Pressing Jaw (for PC-100 or PC-280)	4.30
PC-14S	1 1/2" Standard Pressing Jaw (for PC-100 or PC-280)	9.61
PC-15S	2" Standard Pressing Jaw (for PC-100 or PC-280)	9.26
PC-16S	1/2"-1 1/4" (4 jaws) Standard Press Jaw Kit w/Case (for PC-100 or PC-280)	25.25
PC-17S	1 1/2"-2" (2 jaws) Standard Press Jaw Kit w/Case (for PC-100 or PC-280)	23.76
PC-2	2 1/2" Pressing Chain w/Case (for PC-100 or PC-280)	18.58
PC-3	3" Pressing Chain w/Case (for PC-100 or PC-280)	19.40
PC-4	4" Pressing Chain w/Case (for PC-100 or PC-280)	23.81
PC-234	2 1/2", 3" & 4" Pressing Chain Kit (for PC-100 or PC-280)	44.42
PC-5	PC-5 Pressing Chain Adapter Jaw (note: must be used with 2 1/2", 3" & 4" chains)	7.01
PC-7L	18V, 3.0Ah Lithium-ion Battery (for PC-280 or PC-20M)	1.30
PC-8L	110V Battery Charger (for PC-4ML or PC-7L)	2.20
PC-9L	AC Adapter (for PC-280 or PC-20M)	1.70
PC-280C	Plastic Replacement Case for PC-280 Tool	7.50
PC-2C	Metal Replacement Case for PC-2 or PC-3 Chain	8.10
PC-4C	Metal Replacement Case for PC-4 Chain	8.10
PC-234C	Plastic Replacement Case for PC-234 Chain Kit	7.72
PC-16SC	Metal Replacement Case for PC-16S (1/2" - 1 1/4" Jaws)	8.10
PC-17SC	Metal Replacement Case for PC-17S (1 1/2" - 2" Jaws)	4.40
PC-51	1/2" - 2" Deburring Tool	0.92



PC-10S thru PC-15S

Standard Pressing Jaw

PC-280

Pressing Tool



PC-2 thru PC-4

Pressing Chain



PC-5

Pressing Chain Adapter Jaw



PC-7L

18V, 3.0 Ah
Lithium-ion Battery



PC-8L

110V Battery Charger



PC-51

1/2" - 2" Deburring Tool



PC-9L

AC Adapter

NIBCO® Press System® Tools

PC-20M 1/2" through 1"

MATERIAL LIST

MODEL NO.	DESCRIPTION	LBS.
PC-20M	Mini Pressing Tool, 2 - 18V, 1.3 Ah Lithium-ion batteries, 110V charger & case (NO jaws)	11.00
PC-200M	Mini Pressing Tool, 3 Jaws, 2 - 18V, 1.3 Ah Lithium-ion batteries, 110V charger & case	18.00
PC-1M	1/2" Jaw (for Mini Pressing Tool - PC-10M or PC-20M)	2.09
PC-2M	3/4" Jaw (for Mini Pressing Tool - PC-10M or PC-20M)	2.05
PC-3M	1" Jaw (for Mini Pressing Tool - PC-10M or PC-20M)	2.07
PC-4ML	18V, 1.3Ah Lithium-ion Battery (for PC-20M)	0.80
PC-7L	18V, 3.0Ah Lithium-ion Battery (for PC-280 or PC-20M)	1.30
PC-8L	110V Battery Charger (for PC-4ML and PC-7L)	2.20
PC-9L	AC Adapter (for PC-280 or PC-20M)	1.70
PC-20MC	Plastic Replacement Case for PC-10M & PC-20M)	4.00
PC-50	1/2" - 1" Deburring Tool	0.42



PC-20M
Mini Pressing Tool



PC-200M
Mini Pressing Tool with
1/2", 3/4" and 1" Jaws



PC-1M, 2M, 3M
Mini Pressing Jaw



PC-4ML
18V, 1.3 Ah
Lithium-ion Battery



PC-8L
110V Battery Charger



PC-50
1/2" - 1" Deburring Tool



PC-7L
18V, 3.0 Ah
Lithium-ion Battery



PC-9L
AC Adapter

NIBCO® Press System® Tools

PC-280 & PC-20M FEATURES

TOOLS

Light weight

PC-20M Mini: 3.7 lbs. (without jaw)
PC-280: 9.4 lbs. (without jaw)

Easy to handle / simple design

Jaws rotate 350°
No calibration necessary
No complicated switches or controls
Mini: Ergonomic compact design is easy to use in tight spaces

Interruptible crimp cycle

Safety feature prevents injuries
Can begin crimp, stop to align and level fitting / tube, and complete crimp

Battery

Can be changed during crimp cycle
Lithium-ion has short charging cycle and larger capacity

- PC-4ML: 15 minute recharge time
- PC-7L: 22 minute recharge time

AC Power Adapter

Converts the tool to electric power
Allows continuous use

Service light

Illuminates at 10,000 cycles
Tool will not stop operating when light illuminates

- RED indicates battery charge status, service intervals, tool functions & faults
- WHITE illuminates the work area

Hydraulic Pressure Check (HPC)

An audible warning signal sounds if adequate working pressure is not achieved

PRESSING CHAINS (2 1/2" to 4" ONLY)

Uniform crimp

Maintains proper pipe alignment

Easy to install and remove

Once secured to fitting, chain cannot fall off prior to crimp
Chain easily removed post crimp

Crimp Identification

Easy to identify crimp has been made from a distance

PC-100 and PC-10M Accessories

MATERIAL LIST

MODEL NO.	DESCRIPTION	LBS.
PC-6	12V, NiMH Battery - 2.6Ah for PC-100	1.51
PC-7	12V, NiMH Battery - 3.0Ah for PC-100	1.57
PC-8	120V Standard Battery Charger for PC-6 or PC-7	1.10
PC-9	AC Adapter for PC-100 Press Tool	1.32
PC-4M	1.3 Ah NiCd 9.6V Battery for Mini Pressing Tool	0.85
PC-5M	120V Charger for Mini Pressing Tool	1.13
PC-100C	Metal Case for PC-100 Tool	14.30



PC-4M

9.6V, 1.3 Ah
NiMH Battery



PC-7

12V, 3.0 Ah
NiMH Battery



PC-8

120V Battery Charger



PC-9

AC Adapter

NIBCO® Press System®

Approved Tool and Jaw Compatibility Matrix

Pressing tool, jaw and chain sets are an integral part of ensuring a reliable, permanent connection between NIBCO® Press System® fittings, valves and copper piping. **Only use pressing tools, jaws and chain sets that have been tested and approved for use with NIBCO Press System fittings and valves.**

The following table details compatibility of **approved** pressing tools, chains and jaws with the NIBCO Press System fittings and valves:

	SIZE	1/2" - 1"					1/2" - 2"						2 1/2" - 4"
		1/2" - 1" NIBCO PressSystem Mini Pressing Jaws (PC-1M, PC-2M, PC-3M)	1/2" - 1" RIDGID® ProPress® Compact Pressing Jaws	1/2" - 1-1/4" RIDGID® ProPress® C1 Compact Kit (C1 Actuator & Press Rings)	Rothenberger Compact Pressing Jaws	Stanley® VIRAX® Press Inserts	1/2" - 2" NIBCO PressSystem Standard Pressing Jaws (PC-10S, PC-11S, PC-12S, PC-13S, PC-14S, PC-15S)	1/2" - 2" RIDGID® ProPress® Standard Pressing Jaws	1/2" - 1-1/4" RIDGID® ProPress® V1 Kit (V1 Actuator & Press Rings)	1/2" - 2" Rothenberger Standard Pressing Jaws	1/2" 2" REMS Standard Pressing Jaws	Stanley® VIRAX® Pressing Jaws	2 1/2" - 4" NIBCO Pressing Chains (PC-2, PC-3, PC-4)
PRESSING TOOLS	NIBCO PC-280	—	—	—	—	—	YES	YES	YES	YES	YES	YES	YES
	NIBCO PC-100	—	—	—	—	—	YES	YES	YES	YES	YES	YES	YES
	RIDGID® 320-E	—	—	—	—	—	YES	YES	YES	—	—	—	—
	RIDGID® RP 330-B	—	—	—	—	—	YES	YES	YES	—	—	—	—
	RIDGID® CT400	—	—	—	—	—	YES	YES	YES	—	—	—	—
	RIDGID® RP 330-C	—	—	—	—	—	YES	YES	YES	—	—	—	—
	Rothenberger ROMAX® Pressliner	—	—	—	—	—	—	—	—	YES	—	—	—
	Rothenberger ROMAX® AC ECO	—	—	—	—	—	—	—	—	YES	—	—	—
	REMS Akku-Press	—	—	—	—	—	—	—	—	—	YES	—	—
	REMS Power-Press	—	—	—	—	—	—	—	—	—	YES	—	—
	Stanley® VIRAX® P20+	—	—	—	—	—	—	—	—	—	—	YES	—
	NIBCO PC-20M Mini	YES	—	—	YES	—	—	—	—	—	—	—	—
	NIBCO PC-10M Mini	YES	—	—	YES	—	—	—	—	—	—	—	—
	RIDGID® 100-B Compact	—	YES	YES	—	—	—	—	—	—	—	—	—
	RIDGID® RP 210-B Compact	—	YES	YES	—	—	—	—	—	—	—	—	—
	Rothenberger Compact	YES	—	—	YES	—	—	—	—	—	—	—	—
	Stanley® VIRAX® M20+ Compact	—	—	—	—	YES	—	—	—	—	—	—	—

For the latest listing of approved Pressing tool, jaw and chain combinations, visit nibco.com.
NIBCO recommends minor tool service performed once per year and major service every three years.
For technical or service assistance, contact NIBCO Technical Services 1-888-446-4226.

RIDGID® is a registered trademark of RIDGID Inc.
ProPress® is a registered trademark of Viega NA.
ROMAX® is a registered trademark of ROTHENBERGER USA LLC
VIRAX® is a registered trademark of The Stanley Works.

CAUTION:
NIBCO Press Fittings and Valves (2 1/2", 3", 4" ends) to be installed **ONLY** with NIBCO Pressing Tools & Chains.

NIBCO[®]
pres*s***ystem**[®]
Engineering Data

NIBCO® Press System® — Engineering Data

Copper and Copper Alloy Fittings

Standards

O-Ring seal joints are not new to the piping industry, but joining techniques like the NIBCO® Press System® are providing new alternatives for copper piping assembly. Although there are no nationally recognized standards for these fittings, NIBCO has relied on its century of experience in copper and brass piping products to design the best performing and most dependable line of fittings possible.

Applications

The NIBCO® Press System® fittings are designed to join with ASTM B 88 seamless copper water tube in residential and commercial potable, hot, chilled and process water applications for plumbing and HVAC systems. Copper and copper alloy materials and EPDM elastomeric seals have a long history of compatibility with common chemicals used in these systems. A chemical resistance chart should always be referenced when other fluids are to be introduced.

NOTE: FLUIDS CONTAINING HYDROCARBONS ARE NOT COMPATIBLE WITH THE EPDM SEAL.

Pressure/Temperature Limitations

-20°F to 250°F up to 200 PSIG, non-shock working pressure.

Materials:

- Wrot Copper
 - ◆ ASTM B 75 Alloy C12200
- Cast Copper & Brass Rod Alloy
 - ◆ BS EN 1982:1999 Modified Alloy CC491K
 - ◆ European Red Brass comparable to ASTM B 62
- Elastomeric Seals
 - ◆ EPDM O-Rings compliant with BS EN 681-1

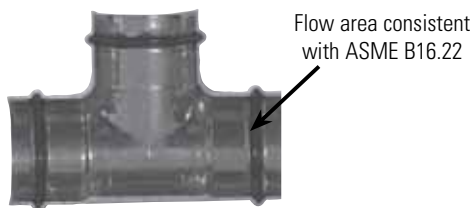

NIBCO® Press Fittings meet all performance requirements of ASME B16.22 and B16.18

NOTE: Freezing Weather Precaution — Subsequent to testing a piping system, valve should be in an open position to allow complete drainage.

Performance

In the absence of a nationally recognized standard, the following performance tests were developed and conducted. The fitting dimensions, materials of construction and performance tests were witnessed and verified by internationally recognized Underwriters Laboratories, Inc. A letter of verification is available upon request:

1. Dimensional Verification
 - a. Inside diameter of press cup and waterway
 - b. Outside diameter of press cup and waterway
 - c. Wall thickness
 - d. Threaded ends conformance to ASME B1.20.1
2. Hydrostatic Minimum Burst Strength Pressure
 - a. Fitting samples hydrostatically tested to a minimum of 600 PSI (three times the rated internal working pressure) at 73°F.
3. Unrestrained Hydrostatic Pressure Test at 68°F (20°C) and 200°F (93°C)
 - a. Fitting assemblies were filled with water and pressurized to 600 PSIG at 68° or 200°F for 48 hours.
4. Static Torque
 - a. Fittings were filled with water, had a minimum torque applied and released. Each fitting was then pressurized to 400 PSIG for 48 hours.
5. Bending Test
 - a. A sample fitting was installed between two equal lengths of hard-drawn copper tubing supported six (6) feet apart. A concentrated load was applied to the center of the fitting. The assembly was subjected to 400 PSIG water pressure for one (1) hour.
6. Vacuum Pressure Test
 - a. Fittings were subjected to a vacuum pressure of 24.5 inches of mercury for one (1) hour.
7. Cyclic Pressure Test
 - a. Fittings were subjected to a hydraulic shock pressure of 400 PSIG for 10,000 cycles.
8. Vibration Test
 - a. Fitting assemblies were subjected to a hydrostatic cyclic vibration test at 350 PSIG for 1,000,000 cycles. After cycling, the assemblies were pressurized to 400 PSIG for 30 minutes.
9. Thermocycling Test
 - a. Fitting and tube assemblies were filled with air and pressurized to 100 PSIG. The water temperature was cycled from 68°F to 200°F for 2,500 cycles. Each temperature was held for 2 minutes and changed within two (2) minutes.
10. Dynamic Torque at 68°F (20°C) and 200°F (93°C)
 - a. Fittings were assembled between two lengths of hard-drawn copper tubing. With one tube fixed, the other tube twisted ±5° for 10,000 cycles at 68°F (20°C) or 200°F (93°C). Each assembly was then subjected to 400 PSIG water pressure at 68°F (20°C) or 200°F (93°C) for 48 hours.

Tests were performed with K, L and M hard drawn-copper tubing. A minimum of one fitting of each configuration of each size was tested.

NIBCO® Press System® — Sample Specification

FITTINGS

2" and Smaller:

Fittings shall comply with NSF 61, CSA, UPC and be approved by the local jurisdiction. The NIBCO® Press System® may be used at the contractor's option for the following building services piping - 20°F to +250°F up to 200 PSI:

- **Hot and Cold Domestic Water**
- **Potable Water**
- **Condenser and Chilled Water Service**
- **Hot Water Heating Service**

Wrot copper press fittings shall be made from commercially pure copper mill products per ASTM B 75 Alloy C12200. Cast copper alloy press fittings shall be made from materials with a minimum of 78% copper and a maximum of 15% zinc. The press fittings connections shall be compatible with seamless K, L or M copper tube made to ASTM B 88. Fittings shall have a maximum non-shock working pressure of 200 PSI between the temperatures of -20°F and +250°F. Elastomeric seals shall be made of EPDM material, and the fittings shall be manufactured with an inboard bead design. All fittings shall be installed in accordance with the manufacturer's installation instructions and according to local plumbing and mechanical codes. The press-to-connect joint shall be made with pressing tools and jaw sets recommended and authorized by NIBCO.

2½" through 4":

Fittings shall comply with NSF 61, CSA, UPC and be approved by the local jurisdiction. The NIBCO® Press System® may be used at the contractor's option for the following building services piping - 20°F to +250°F up to 200 PSI:

- **Hot and Cold Domestic Water**
- **Potable Water**
- **Condenser and Chilled Water Service**
- **Hot Water Heating Service**

Wrot copper press fittings shall be made from commercially pure copper mill products per ASTM B 75 Alloy C12200. Cast copper alloy press fittings shall be made from materials with a minimum of 78% copper and a maximum of 15% zinc. The press fittings connections shall be compatible with seamless K, L or M copper tube made to ASTM B 88. Fittings shall have a maximum non-shock working pressure of 200 PSI between the temperatures of -20°F and +250°F. Elastomeric seals shall be made of EPDM material, and the fittings shall be manufactured with an inboard bead design. All fittings shall be installed in accordance with the manufacturer's installation instructions and according to local plumbing and mechanical codes. The press-to-connect joint shall be made with pressing tools and jaw sets recommended and authorized by NIBCO.

NIBCO® Press System® — Sample Specification

VALVES

2" and Smaller Ball Valves: (On/Off, Isolation or Throttling)

Ball valves with male or female press-to-connect ends shall be rated at 200 PSI CWP to +250°F maximum. Valves shall be manufactured in accordance with MSS SP-110 and constructed of dezincification resistant cast bronze bodies. No brass containing more than 15% zinc shall be approved. Valve shall have reinforced PTFE seats, blow-out proof stem, full-port ball, chrome/nickel plated ball or 316 SS ball for aggressive water conditions. Where piping is to be insulated, ball valves shall be equipped with 2" extended handles of non-thermal conductive material. Handle to have extended sleeve incorporating an insulation plug to provide a vapor barrier and allow valve operation without disturbing the insulation, and a memory stop, which can be set after installation.

Acceptable Valves: (non-insulated lines):

NIBCO® PC585-70, PF585-70 or PS585-70
(Chrome/nickel plated ball)
NIBCO® PC585-70-66, PF585-70-66, PS585-70-66 or PCM585-60
(316 SS ball)

Acceptable Valves: (insulated lines):

NIBCO® PC585-70-NS, PF585-70-NS or PS585-70-NS
(Chrome/nickel plated ball)
NIBCO® PC585-70-66-NS, PF585-70-66-NS or PCM585-60-NS
(316 SS ball)

(Note to Specifier: Include press gate valves in addition/in lieu of press ball valves for ON/OFF and isolation services if requested or required.)

2" and Smaller Gate Valves: (On/Off and Isolation)

Gate valves with male or female press-to-connect ends shall be rated to 200 PSI CWP at +250°F maximum. Valves shall be manufactured in accordance with MSS SP-80. Valve body, bonnet and wedge to be manufactured of dezincification resistant cast bronze (ASTM B 62). Stems shall be of silicon bronze (ASTM B 371) or low zinc alloy (ASTM B 99). Non-asbestos packing and malleable or ductile iron hand-wheel shall be standard.

Acceptable Valves:

NIBCO® PF111 or PS111 - Rising Stem Gate Valve
NIBCO® PF113 or PS113 - Non-Rising Stem Gate Valve

2" and Smaller Globe and Angle Valves: (Throttling Service)

Globe and angle valves with male or female press-to-connect ends shall be rated to 200 PSI CWP at +250°F maximum. Valves shall be manufactured in accordance with MSS SP-80. Valve body, bonnet and wedge to be manufactured of dezincification resistant cast bronze (ASTM B 62). Stems shall be of silicon bronze (ASTM B 371) or low zinc alloy (ASTM B 99). Non-asbestos packing and malleable or ductile iron hand-wheel shall be standard.

Acceptable Valves:

NIBCO® PF211-Y or PS211-Y - Globe Valve
NIBCO® PF311-Y or PS311-Y - Angle Valve

2" and Smaller Check Valves: (Back Flow Prevention)

Check valves (Y pattern, swing type or in-line) with male or female press-to-connect ends shall be rated at 200 PSI CWP to +250°F maximum. Valves shall be manufactured in accordance with MSS SP-80. Body and cap to be manufactured of dezincification resistant cast bronze (ASTM B 62 or ASTM B 584 Alloy C84400). Valves to have PTFE seat disc.

Acceptable Valves:

NIBCO® PF413-Y or PS413-Y - Y Pattern, Swing Type Check Valve
NIBCO® PF480-Y or PS480-Y - In-line spring loaded Silent Check Valve

Drain Valves

At all low points in water piping to be drained or vented, provide 1/2" or 3/4" ball valves with male or female press-to-connect ends by hose-end drain valves. Valves shall be rated by 200 PSI CWP to +250°F maximum. Valves shall be manufactured in accordance with MSS SP-110. Valves to be constructed of dezincification resistant cast bronze bodies. Valve shall have reinforced PTFE seats, blow-out proof stem, and be full port. All valves shall be provided with 3/4" hose connection with cap and chain.

Acceptable Valves:

NIBCO® PS585-70-HC or PF585-70-HC

2 1/2" thru 4" Butterfly Valves: (On/Off, Isolation or Throttling)

Butterfly valves with female press-to-connect ends shall be rated at 200 PSI CWP to +250°F maximum. Valves shall be manufactured in accordance with MSS SP-67 and constructed of a ductile-iron body, for bubble-tight shutoff, extended-neck for insulation, disc and lining suitable for potable water, valves shall be suitable for bi-directional dead end service at full rated pressure, one-piece Type 416 stainless-steel stem, copper bushing, fasteners and pins shall not be used to attach stem to disc, no pins or fasteners in water-way, aluminum-bronze disc, and molded-in EPDM seat (liner).

Acceptable Valves:

NIBCO® PFD2000 Series

NIBCO[®] **pres**system[®] **Installation Instructions**

NIBCO® Press System® — Installation Instructions

NIBCO® Press System®

The NIBCO® Press System®, when used with tested and authorized pressing tools and jaws, is designed to mechanically crimp fittings and valves onto copper tubing to create a watertight, permanent seal. When the switch on the pressing tool is depressed, an internal motor powers a hydraulic pump which forces fluid into the cylinder of the tool, forcing the ram forward and applying thousands of pounds of crimping force onto the specially designed fittings and valves.

System Components

Fittings and Valves

NIBCO® Press System® copper or bronze fittings and valves

Tubing

ASTM B 88 seamless Hard Drawn Copper Water Tube: Types K, L and M.

Pressing Tools, Chains and Jaws

The pressing tool, chain and jaw are important parts of ensuring a reliable, permanent connection between NIBCO® Press System® fittings and valves and the copper water tube.

CAUTION — Use only pressing tools and jaw sets that have been tested and authorized for use with NIBCO® Press System® fittings and valves ⁽¹⁾. Use of unauthorized pressing tools and/or jaws may result in an improper seal that could cause extensive property damage.

(1) See approved tool and jaw compatibility matrix on page 52.

Pressing Tool Safety

- Only use authorized pressing tools and jaws with NIBCO® Press System® fittings and valves. Other uses or modification of the jaws for other applications may damage the press tool, damage the jaws and/or cause personal injury.
- Keep fingers and hands away from jaws during pressing cycle. Your fingers or hands can be crushed, fractured or amputated if they become caught between the jaw tips or between the jaw and any other object.
- Always wear safety glasses while using pressing tools and jaws.
- Never attempt to repair a damaged jaw set. A jaw that has been welded, ground, drilled or modified in any manner can shatter during crimping resulting in serious injury. Discard the entire damaged jaw set. Replace with a new jaw set.

NOTE: Consult manufacturer's pressing tool and jaw set operators manual to determine replaceable jaw set components.

WARNING: Please read these installation instructions and the manufacturer's pressing tool and jaw operators manual(s) carefully prior to installation of the NIBCO® Press System®. Failure to understand and follow the contents of this manual may result in extensive property damage, severe personal injury or death.

Please contact NIBCO Technical Services at 888.446.4226 if you have installation questions.

NIBCO® Press System® — Installation Instructions

Installation Instructions for 1/2" - 2" Press Fittings and Valves

WARNING: To prevent serious injury, inspect the pressing tool, battery charger (if applicable) and jaw sets according to the procedure outlined in the pressing tool instruction manual prior to beginning installation.

Failure to clean jaws can result in an improper connection that can lead to extensive property damage.

Work Area Set-Up

To prevent serious injury, proper set-up of the pressing tool and work area is required. The following procedure should be followed:

1. Check work area for:
 - Adequate lighting
 - Flammable liquids, vapors or dust that may ignite
2. Follow the tool set-up procedures specified in the manufacturer's pressing tool instruction manual.

Preparing the Copper Tube

1. Select clean, undamaged copper tube and cut to desired length. Cut tube end square using a tube cutter or fine-toothed saw (*Figure 1*).



Figure 1 — Cut tube to desired length using a tube cutter

2. Deburr the tube inside and outside diameter using a half-round file or a deburring tool.
3. Clean the tube end of all dirt, oil and grease. (Emery cloth or sandpaper to clean the tube or remove oxidation is not required.)

Inserting the Tube into the Fitting or Valve

1. Check the fitting to make sure the EPDM seal is in place, clean and free of oil and grease (*Figure 2*).



Figure 2 — Check for EPDM Seal

WARNING: Never lubricate the EPDM seal in the NIBCO® Press System® fitting or valve with anything other than water. Oil-based lubricant, dirt or debris may damage the seal. An improper seal can lead to extensive property damage.

2. Insert the tube into the fitting or valve using a twisting motion. Make sure that the tube is fully inserted into the fitting stop or shoulder.
3. Mark the tube with a permanent marker to indicate the proper tube insertion depth (*Figure 3*).



Figure 3 — Inserting the tube to proper depth

4. Refer to the minimum insertion depth table for correct depths

Tube Size	Insertion Depth (min.)	
	Inches	mm
1/2	11/16	18
3/4	7/8	22
1	7/8	22
1¼	1	25
1½	1¾	35
2	1½	38

CAUTION: Tubing that is difficult to insert may have burrs or could be out-of-round. Burrs must be removed and tubing end should be undamaged. Make sure tube is inserted to the proper depth. Failure to do so may result in an improper seal.

Attaching Pressing Jaws

1. Make sure the battery is removed or the cord is unplugged on the pressing tool prior to attaching or changing the crimp jaws.
2. Push and twist to open the jaw set mounting pin. (*Figure 4*).



Figure 4 — Pushing and twisting to open the jaw set mounting pin

3. If press tool contains a jaw set, slide it out of the crimping tool.

NIBCO® Press System® — Installation Instructions

4. Select the jaw set that corresponds to the size of the joint to be crimped and insert the jaw set into the pressing tool (*Figure 5*).



Figure 5 — Inserting the NIBCO® Press System® jaw

5. Push the jaw set mounting pin until it clicks into position.
NOTE: The tool will not work unless the pin is fully engaged.

Crimping a NIBCO® Press System® Fitting or Valve

1. Make sure the tubing is inserted to the proper depth in the fitting, and that tube and fitting are aligned properly. (*Figure 6*).

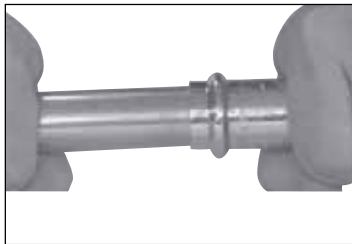

Figure 6 — Inserting the tube to proper depth

2. Squeeze jaw arms to open the jaw set.
3. Place the open jaws around the fitting and ensure that the contour of the jaw is properly aligned with the contour of the fitting (*Figure 7*).



Figure 7 — Open the jaw set and place around the fitting

4. Make sure the tool is square to the tubing and depress the switch (*Figure 8*). Once the crimp cycle begins and the rollers contact the jaw arms, the tool will complete the crimp cycle, as long as the trigger is depressed.

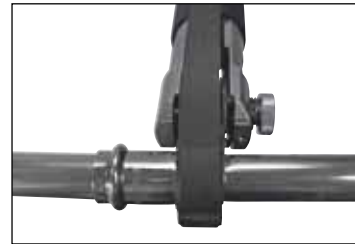

Figure 8 — Jaw set should be square to tubing

5. Once the crimp is complete, press the jaw arms to open the jaw and remove from the fitting.

If the tool malfunctions, please refer to the tool instruction manual for troubleshooting suggestions.

CAUTION Avoid sharp edges that may have formed on the fitting during the crimping operation.

Inspecting the Crimp

1. Inspect the crimped fitting to ensure proper crimp.

NOTE: The use of the NIBCO® Press System® jaw will produce a unique witness mark "N" on the crimped fitting.

2. Inspect the crimped fitting checking the connection for the following problems:

- Misaligned tube
- Not fully inserted tube, double check depth marks
- Incorrect jaw alignment with the fitting contour

If one or more of these problems are found, a new section of tubing and a new fitting will need to be prepared, installed and crimped.

3. Test the NIBCO® Press System® in accordance with normal practice and to local jurisdiction piping code.

NIBCO® Press System® — Installation Instructions

Installation Instructions for 2 1/2" - 4" Press Fittings and Valves

WARNING: To prevent serious injury, the pressing tool, battery charger (if applicable) and pressing chains should be inspected according to the procedure outlined in the pressing tool instruction manual prior to beginning installation.

Failure to clean pressing chains can result in an improper connection that can lead to extensive property damage.

Work Area Set-Up

To prevent serious injury, proper set-up of the pressing tool and work area is required. The following procedure should be followed:

1. Check work area for:
 - Adequate lighting
 - Flammable liquids, vapors or dust that may ignite
2. Follow the tool set-up procedures specified in the pressing tool instruction manual.

Preparing the Copper Tube

1. Select clean, undamaged copper tube and cut to the desired length. Cut tube end square using a tube cutter or fine-toothed saw (Figure 1).



Figure 1: Cut tube to desired length using a tube cutter

2. Deburr the tube inside diameter using a half-round file or deburring tool. Remove any copper shavings or filings (Figures 2 & 3).



Figure 2: Deburr inside diameter using a half-round file



Figure 3: Deburr inside diameter deburring tool

3. Deburr the tube outside diameter using a half-round file to prevent damage to the EPDM seal (Figure 4).



Figure 4: Deburr outside diameter using a half-round file

4. Clean the tube end of all contamination, oils and shavings. A smooth transition chamfer is recommended to ease tube insertion past the seal. (Emery cloth or sandpaper to clean the tube or remove oxidation **is not required**.)

Inserting the Tube into the Fitting or Valve

1. Check the fitting to make sure that the seal is in place and is free of oil or grease. Only original NIBCO® EPDM seals are to be used when making a press connection with NIBCO® Press System® fittings and valves. If it is necessary to lubricate the seals, use water only. **DO NOT** use any petroleum-based lubricants (Figure 5).



Figure 5: Check for EPDM seal

WARNING: Never lubricate the EPDM seal in a NIBCO® Press System® fitting or valve with anything other than water. Oil-based lubricants, dirt or debris may damage the seal. An improper seal can lead to extensive property damage.

2. Mark the proper insertion depth on the tube with a permanent marker prior to insertion, based on insertion depth chart. Refer to minimum insertion depth table for correct depths.

NIBCO® Press System® Insertion Depth Chart			
Tube Size	2 1/2"	3"	4"
Insertion Depth (min.)	1 1/2"	1 5/8"	2 1/8"

WARNING: If tube is not inserted to the proper depth, an inadequate seal may result.

3. Insert the tube into the fitting or valve using a twisting motion. Make sure that the tube is fully inserted into the fitting or valve. If tube is not inserted to the proper depth, an inadequate seal may result.

CAUTION: Tubing that is difficult to insert may have burrs or could be out-of-round. Burrs must be removed and tubing end should be undamaged. Make sure tube is inserted to the proper depth. Failure to do so may result in an improper seal.

NIBCO® Press System® — Installation Instructions

Crimping a NIBCO® Press System® Fitting or Valve

CAUTION:

NIBCO Press Fittings and Valves (2½", 3", 4" ends) to be installed **ONLY** with:

- NIBCO PC-100 Pressing Tool
- NIBCO PC-5 Adapter Jaw
- NIBCO Pressing Chain - 2½" (PC-2), 3" (PC-3), 4" (PC-4)

1. Make sure that the battery is removed or that the cord is unplugged on the pressing tool prior to attaching or changing the adapter jaw.
2. Select the correct size pressing chain. Pull the pin on the chain which allows the segments to open. Position the chain on the raised bead and wrap the chain around the fitting with the "pipe side" designation facing the tube. When the chain is fully wrapped around the fitting, reinsert the pin to secure the chain on the assembled joint. Visually inspect the mark made for insertion depth, to ensure the tube remained in position (Figure 6).



Figure 6: Placement of the pressing chain onto fitting or valve

3. Release the pin (push and twist) on the jaw holder of the pressing tool, and install the adapter jaw on the tool. Return the pin to its original position, securing the jaw. The red sleeve on the tool must be in the back position to allow for crimping sizes 2½", 3" and 4". (The red sleeve in the forward position allows for use with ½" - 2" standard pressing jaws.) Rollers on the pressing tool must be in the forward position to allow the red sleeve to move forward (Figure 7).



Figure 7: Placement of adapter jaw into the tool

4. Squeeze adapter jaw arms to open the jaw. Rollers must be fully retracted to open the adapter jaw. Place the open adapter jaw into the grooves in the pressing chain and let go of the jaw arms (Figure 8).



Figure 8: Placement of adapter jaw into pressing chain

5. Make sure the tubing is inserted to the proper depth in the fitting or valve, and that the tube and fitting or valve are aligned properly.
6. With the pressing tool perpendicular to the tube, begin the pressing cycle by pulling the trigger of the pressing tool.
7. Allow the pressing cycle to complete. Remove the pressing tool and adapter jaw from the pressing chain. Remove the pressing chain from the fitting.

If the tool malfunctions, please refer to the tool instruction manual for troubleshooting suggestions.

CAUTION: Avoid sharp edges that may have formed on the fitting during the crimping operation.

Inspecting the Crimp

1. Inspect the crimped fitting or valve to ensure proper crimp. The final crimp should appear pressed uniformly around the fitting or valve (Figure 9).



Figure 9: Inspection of final crimp

NOTE: The use of the NIBCO® Press System® chain will produce a unique witness mark "N".

2. Inspect the crimped fitting checking the connection for the following problems:
 - Misaligned tube
 - Not fully inserted tube, double check depth marks
 - Incorrect chain alignment with the fitting contour

If one or more of these problems are found, a new section of tubing and a new fitting will need to be prepared, installed, and crimped.

3. Test the NIBCO® Press System® in accordance with normal practice and to local jurisdiction piping code.

NIBCO® Press System® — Testing Instructions for Fittings & Valves with Leak Detection

PRESSURE TESTING:

NIBCO recommends the following leak testing procedures when installing NIBCO Press System with the leak detection feature. These test procedures allow the installer to find un-pressed connections while the system is being tested under pressure. The uniquely designed EPDM o-ring allows fluids or gases to flow past the seal and leak when the fitting has not yet been pressed. When the fitting has been pressed, the o-ring will create a water tight seal around the tube.

AIR LEAK TESTING

1. Pressurize system up to 15 psi maximum using dry, oil free compressed air, carbon dioxide, or nitrogen.
2. Allow system pressure to stabilize for a minimum of 2 hours.
3. If system pressure has dropped, add more air to bring entire system up to 15 psi maximum. If system pressure increases above 15 psi, bleed off excess pressure to ensure system is at a maximum pressure of 15 psi.
4. If the system pressure continues to drop, inspect all joints for un-pressed fittings. The NIBCO® Press System® press fittings with the leak detection feature are designed to leak in an un-pressed condition.
5. Check all press joints for air leaks using a commercially available leak test solution or a soap and water mixture.
6. Once the system has been confirmed to be leak free, pressure can be increased to the recommended working pressure to verify system integrity.

WATER LEAK TESTING

1. Pressurize system up to 50 psi maximum using potable water.
2. Allow system pressure to stabilize for a minimum of 2 hours.
3. If system pressure has dropped, add more water to bring entire system up to 50 psi maximum. If system pressure increases above 50 psi, bleed off excess pressure to ensure system is at a maximum pressure of 50 psi.
4. If the system pressure continues to drop, inspect all joints for un-pressed fittings. The NIBCO® Press System® press fittings with the leak detection feature are designed to leak in an un-pressed condition.
5. Check all press joints for leaking water.
6. Once the system has been confirmed to be leak free, water pressure can be increased to the recommended working pressure to verify system integrity.

NIBCO® Press System® — Installation Instructions

Minimum Distance Between Joints

To prevent distortion of the tubing, certain fitting sizes require a minimum distance between crimp joints (refer to *Chart 1* below). Failure to provide this minimum distance may result in an improper seal.

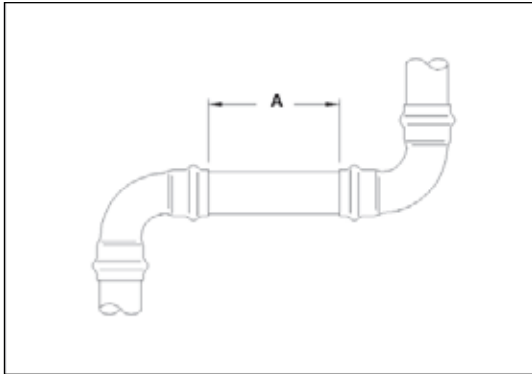

Tube Dia.	A (min.)	
	Inches	mm
1/2**	0	0
3/4**	0	0
1**	0	0
1 1/4**	0	0
1 1/2**	0	0
2**	0	0
2 1/2"	3/8"	10
3"	3/8"	10
4"	3/8"	10

*No minimum distance required.

System Support

CAUTION — In any installation, the system should be supported to ensure the minimum stress is imposed on the tube and joints. The NIBCO® Press System® should be supported in accordance with normal practice and to local jurisdiction piping code.

Annealing of Copper Tube

A NIBCO® Press System® installation should not be conducted within 12" of a **brazed** joint. The high temperature required for capillary joinery may cause the copper tube to become annealed and render it too soft for proper crimping. However, a NIBCO® Press System® product may be crimped adjacent to a **soldered** joint, as normal temperatures created by silver soldering are not hot enough to cause the copper tube to become annealed.

CAUTION — Brazing or soldering should not be conducted within 12" of an existing NIBCO® Press System® connection as this may damage the EPDM seal. If there is any concern about heat damage to the o-ring, a cold, wet cloth should be wrapped around the crimped connection

Spacing

- Sufficient clearance must be left around each joint to allow room for the pressing tool and jaw to be attached without interference.

Clearance Requirements — Standard Jaw Sets

Tool perpendicular to wall

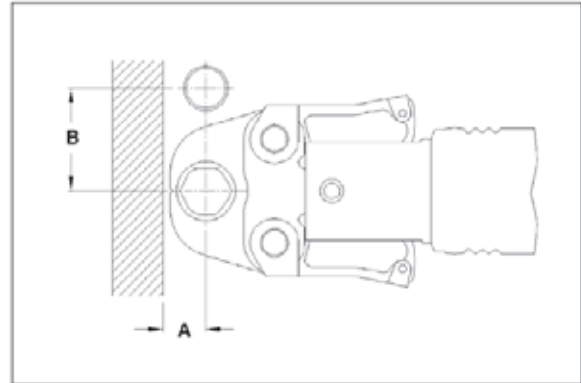

Tube Dia.	A (min.)		B (min.)	
	Inches	mm	Inches	mm
1/2	15/16	24	1 5/8	41
3/4	7/8	22	2 1/8	54
1	1 1/4	31	2 1/2	64
1 1/4	1 1/8	29	2 7/8	73
1 1/2	2	51	4 3/8	111
2	2	51	4 3/8	111

Tool angled to wall

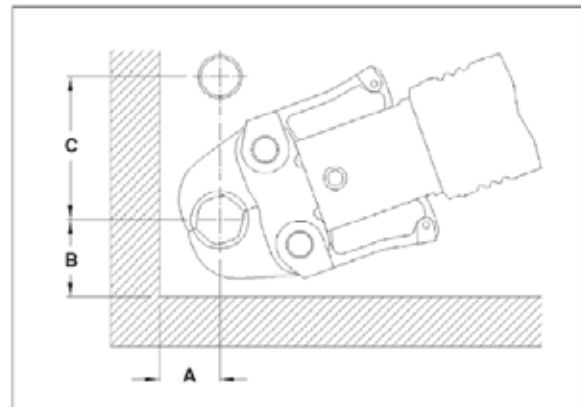

Tube Dia.	A (min.)		B (min.)		C (min.)	
	Inches	mm	Inches	mm	Inches	mm
1/2	1 1/8	28	1 3/8	35	2 1/2	64
3/4	1	26	1 1/2	38	2 1/2	64
1	1 5/16	34	1 3/4	45	3	76
1 1/4	1 1/4	32	2 1/4	57	3 1/8	80
1 1/2	2 1/8	54	3 1/8	80	5	127
2	2 1/8	54	3 1/8	80	5	127
2 1/2	3 5/8	92	6	152	3 1/2	89
3	3 7/8	98	6 1/2	165	4	102
4	4 7/8	124	7 5/8	194	4 1/4	108

NOTE: Clearance dimensions for 2 1/2", 3" & 4" are for wrap-ping pressing chains around fittings.

NIBCO® Press System® — Frequently Asked Questions

What is the NIBCO product offering?

The NIBCO® Press System® features a full range of copper and copper alloy fittings, commercial valves, accessories and pressing tools, jaws and chains for use with K, L and M copper water tube.

What is the system temperature rating?

The NIBCO® Press System® is rated at 200 PSIG over a temperature range of -20°F to 250°F.

What are the approved system applications?

Approved applications include residential and commercial potable, hot, chilled and process water for plumbing and HVAC systems. The NIBCO® Press System® is designed for use with water glycol mixtures of ethylene or propylene glycol up to 50% at 200°F.

What was the testing protocol for the NIBCO® Press System® fittings and valves?

NIBCO® Press System® fittings and valves were subjected to a wide range of performance tests including dimensional verification, thread end specification, hydrostatic burst strength, unrestrained pressure, static torque, bending, vacuum pressure, cyclic pressure, vibration, thermo-cycling and dynamic torque. The testing protocol included testing to a 3X safety factor above the 200 PSIG system rating.

NIBCO testing was witnessed and validated by the internationally recognized Underwriters Laboratories, Inc. (UL).

Can other available pressing tools and jaws be used on the NIBCO® Press System®?

See page 52 for a complete listing of approved tools and jaws.

Can a NIBCO® Press System® connection be re-crimped?

If for any reason the press cycle is interrupted, it is possible to re-crimp a NIBCO® Press System® connection. However, when re-crimping the connection, the jaws must be properly aligned so that the crimp is performed in the same location as the original.

How long will the EPDM seal last?

Accelerated life tests show that the EPDM seals used with the NIBCO® Press System® fittings and valves have a life expectancy of 50 years.

Are NIBCO® Press System® fittings available with solder or threaded by Press System connection?

NIBCO offers many Press System fitting combinations by soldered or threaded connection. Please note, always solder the standard wrot connection first when possible. Prior to soldering, remove the press end EPDM o-ring, solder, allow the fitting to cool, insert the EPDM o-ring, and then Press the connection.

Can a fitting be soldered close to a Press System connection?

NIBCO recommends soldering at least 12 inches away from the Press System connection. If this length is not possible, either solder the joint prior to connecting the press fitting or wrap the connection with a cold wet cloth.

Is the NIBCO® Press System® approved for underground use?

In accordance with local plumbing codes, the NIBCO® Press System® can be installed underground.

Is the NIBCO® Press System® compatible with standard disinfectant cleaning agents commonly utilized in a new water system?

Yes, the NIBCO® Press System® is typically compatible. For specific cleaning agent compatibility, contact NIBCO Technical Services at the below noted number.

NIBCO® Press System® Fittings Limited Warranty

NIBCO INC. warrants:

- NIBCO® Press System® fittings to be free from defects in materials and workmanship under normal use and service, for a period of 50 years from the Warranty Commencement Date. The Warranty Commencement Date for NIBCO® Press System® fittings shall be the date upon which the fitting is installed.

NIBCO does NOT warrant against failure of NIBCO® Press System® fittings (referred to hereafter as "product") for:

1. any product, parts or systems which are not manufactured or sold by NIBCO INC.;
2. any product which is used for any purposes other than a purpose authorized by NIBCO INC.;
3. any product not installed in accordance with either the recommended installation guidelines provided by NIBCO INC. and/or applicable plumbing codes;
4. damage to the product caused by, contributed in whole or in part by, or resulting from, any of the following:
 - a. abuse, misuse, mishandling, tampering, neglect or accidental damage, such as, without limitation, vandalism
 - b. natural disasters, such as, without limitation, flooding, windstorm and lightning
 - c. attachments or modifications to the product that are not authorized by NIBCO INC.
 - d. external causes, where external, physical or chemical qualities produce damage to the product, such as, without limitation, variation in water quality, aggressive water or an unsuitable or hostile environment, or
 - e. any other cause beyond the control of NIBCO INC.

NIBCO shall NOT be liable under any circumstances for any other direct or indirect, incidental or consequential damages of any kind, including but not limited to loss of business, lost profits, mold intrusion, water damage, etc. The liability of NIBCO under this warranty is solely limited to the repair or replacement, including installation expenses, of any product that has been determined by NIBCO INC., or an authorized representative or agent thereof, to contain a defect in material or workmanship.

This warranty is the only warranty for the product provided by NIBCO INC., and is and shall be in lieu of any and all other warranties, expressed or implied, including but not limited to an implied warranty of merchantability, and for all other obligations or liabilities on the part of the Manufacturer. No employee of NIBCO INC., or any other distributor, agent or other person or business, is authorized to make any other warranty on behalf of NIBCO INC.

In the event any defect occurs which is believed to be covered by this warranty, NIBCO Technical Services should be immediately contacted either in writing or by telephone at 888.446.4226. NIBCO Technical Services will make further arrangements for the product's return to NIBCO INC. for review and evaluation. In the event that a returned product is determined by NIBCO INC. to be defective, NIBCO INC. will remediate the failure by repairing or replacing the product within a reasonable time, without charge to the owner of the product.

This warranty gives you specific legal rights, and you may also have other rights which vary from state to state.

NIBCO® Press System® Valves

5 year
125%
warranty

NIBCO INC. 125% LIMITED WARRANTY

Applicable to NIBCO INC. Pressure Rated Metal Valves

NIBCO INC. warrants each NIBCO® pressure rated metal valve to be free from defects in materials and workmanship under normal use and service for a period of five (5) years from date put into service.

In the event any defect occurs which the owner believes is covered by this warranty, the owner should immediately contact NIBCO Technical Services, either in writing or by telephone at (888) 446-4226 or (574) 295-3000. The owner will be instructed to return said product, at the owner's expense, to NIBCO INC., or an authorized representative for inspection. In the event said inspection discloses to the satisfaction of NIBCO INC. that said valve is defective, it will be replaced at the expense of NIBCO INC. Replacements shall be shipped free of charge to the owner. In the event of the replacement of any valve, NIBCO INC. shall further pay the owner the greater of Twenty-Five (25%) Percent of the price of the valve according to the NIBCO INC. published suggested list price schedule in effect at the time of purchase, or Ten (\$10.00) Dollars, to apply on the cost of the installation of said replacement valve.

TO THE EXTENT PERMITTED BY LAW, THIS WARRANTY SPECIFICALLY EXCLUDES INCIDENTAL AND CONSEQUENTIAL DAMAGES OF EVERY TYPE AND DESCRIPTION RESULTING FROM ANY CLAIMED DEFECT IN MATERIAL OR WORKMANSHIP, INCLUDING BUT NOT LIMITED TO, PERSONAL INJURIES AND PROPERTY DAMAGES. Some states or countries do not allow the exclusion or limitation of incidental or consequential damages so these limitations may not apply to you. TO THE EXTENT PERMITTED BY LAW, IMPLIED WARRANTIES OF MERCHANTABILITY AND FITNESS FOR A PARTICULAR PURPOSE ARE LIMITED IN DURATION.

This warranty gives you specific legal rights, and you may also have other rights which vary from state to state and country to country.



how to order

State quantity, figure number and size for each valve you wish to order. See individual valve catalog pages for specific or special product designations.

HOW MANY TO ORDER

NIBCO valves are decimal packed for your convenience in handling, shipping and stock-keeping. Number in master carton varies with item.

POLICY ON RETURNS TO FACTORY

NO NIBCO® valves are to be returned without prior written agreement. Transportation must be prepaid. A 20% charge will be made to cover cost of rehandling and reinspection.

TECHNICAL ASSISTANCE

Engineers, contractors, wholesalers or manufacturers may obtain special or technical assistance from any factory representative of NIBCO. Write, fax or phone.

NIBCO INC.
World Headquarters
1516 Middlebury Street
Elkhart, IN 46516-4740
USA

Phone: 1.574.295.3000

Fax: 1.574.295.3307

Technical Service Phone: 1.888.446.4226

Fax: 1.888.336.4226

To the best of our knowledge the information contained in this publication is accurate. However, NIBCO® does not assume any liability whatsoever for the accuracy or completeness of such information. Final determinations of the suitability of any information or product for the use to be contemplated is the sole responsibility of the user. The manner of that use, and whether there is any infringement of patents, is also the sole responsibility of the user.

NOTES

NOTES

globally connecting you at all levels

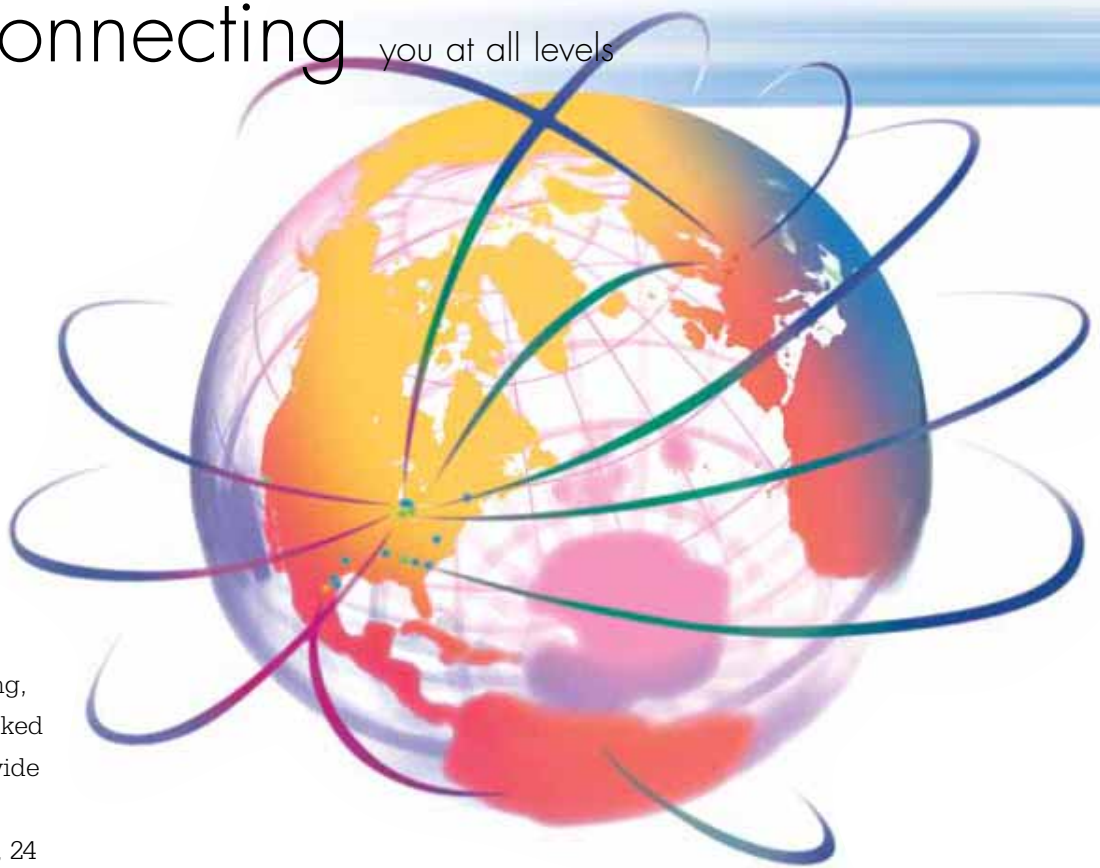

It's a new age of business, and a new way at NIBCO. From Elkhart, Indiana to Lodz, Poland, and points beyond, our company has integrated manufacturing, distribution, and networked communications to provide a seamless source of information and service, 24 hours a day, 7 days a week. But this integration hasn't happened overnight. It's been part of a long-term strategic process that has pushed us to reconsider every aspect of our business. The result? We're a vertically integrated manufacturer with the products and systems in place to deliver low cost and high quality. NIBCO® products are manufactured under a Quality Management System conforming to the current revision of ISO-9001 International Standards. We know the flow control industry is only going to get more demanding, and we are more than ready. We will continue to lead. That's what NIBCO is all about.



FEATURING NIBCO® SYSTEMS

C-NPS-0812

NIBCO® PEX Piping Systems • NIBCO® Press System®

FITTINGS



Wrot and cast copper pressure and drainage fittings • Cast copper alloy flanges
• Wrot and cast press fittings • ABS and PVC DWV fittings • Schedule 40 PVC pressure fittings • CPVC CTS fittings • CPVC CTS-to-metal transition fittings
• Schedule 80 PVC and CPVC systems • CPVC metric piping systems
• CPVC BlazeMaster® fire protection fittings • Lead-Free* fittings

BlazeMaster® is a registered trademark of The Lubrizol Corporation.
*Weighted average lead content ≤0.25%

VALVES & ACTUATION

Pressure-rated bronze, iron and alloy-iron gate, globe and check valves • Pressure-rated bronze ball valves • Boiler specialty valves • Commercial and industrial butterfly valves • Circuit balancing valves • Carbon and stainless steel ball valves
• ANSI flanged steel ball valves • Pneumatic and electric actuators and controls
• Grooved ball and butterfly valves • High performance butterfly valves • UL/FM fire protection valves • MSS specification valves • Bronze specialty valves • Low pressure gate, globe, check and ball valves • Frostproof sillcocks • Quarter-turn supply stops • Quarter-turn low pressure valves • PVC ball valves • CPVC CTS ball valves • Just Right® recirculating valves • Bronze & Iron Y-Strainers
• Lead-Free* valves

*Weighted average lead content ≤0.25%



CHEMTROL®



Thermoplastic pipe, valves and fittings in PVC, Corzan® CPVC, polypropylene and PVDF Kynar® • Pneumatic and electric actuation systems

Corzan® is a registered trademark of The Lubrizol Corporation. • Kynar® is a registered trademark of Arkema Inc.

eNIBCO

EDI—Electronic Data Interchange • VMI—Vendor Managed Inventory
• NIBCO.com • NIBCOpartner.com



NIBCO®

NIBCO INC.
WORLD HEADQUARTERS
WEB: www.nibco.com



RTC GLOBAL
International Procurement & Trading Company

TO ORDER

T	+1613 276 8698
F	+1613 249 7144
E	yazeed@rtcglobal.ca
W	www.rtcglobal.ca

INTERNATIONAL OFFICE
PHONE: +1/574.295.3327
FAX: +1/574.295.3455