

# NIBCO®



## Press Fittings and Valves Catalog

C-NPS-0724

Press-to-Connect Fittings Include Adapters, Caps, Couplings,  
Elbows, Flanges, Manifolds, Tees and Unions.



## QUALITY PRODUCTS SINCE 1904

A recognized brand leader bringing flow control products and technologies to market, NIBCO has a history of success and innovation in the plumbing industry.

Headquartered in Elkhart, Indiana, we operate multiple manufacturing plants and distribution centers strategically located throughout the United States and globally, and offer more than 36,000 SKUs, including our NIBCO® family brands, Webstone®, Chemtrol® and Sure Seal®.

We have vertically integrated manufacturing, distribution and networked communications to provide a seamless source of information and service, 24/7. We place great emphasis on personal connections with our factory direct sales, live customer service and technical service support. We also offer unique programs to support our customers' success, including our NIBCO Partner program, Vendor Managed Inventory and EDI for wholesalers.

More than 90 percent of NIBCO-branded products are manufactured in the U.S. using high-quality materials and innovative processes and technologies to improve product performance and quality. For every high-quality valve or fitting made at NIBCO, each is made with pride by the hundreds of NIBCO associates who work there.

Today, NIBCO is a fifth-generation, family- and associate-owned business. Since 1904, we've pioneered many products and processes. As the flow control industry continues to become more demanding, we remain focused on what has made us successful: delivering more than a product and making business better for each of our customers.



[VISIT OUR WEBSITE TO LEARN MORE](#)

# NIBCO® Press System Table of Contents



Visit our website for the most current information.

	Page		Page
<b>Contents</b> .....	1	PCFU-FP-600A-LF Lead-Free Ball Valve .....	43
<b>Fittings</b> .....	3-10	PCMU-FP-600A-LF Lead-Free Ball Valve .....	44
Applications Chart .....	4	PCSU-FP-600A-LF Lead-Free Ball Valve .....	45
Adapters.....	5	PCU-FP-600A-LF Lead-Free Ball Valve .....	46
Caps .....	5	PC-FP-600A-S-LF Lead-Free Slip Valve .....	47
Couplings .....	6	PC-FP-485-LF Lead-Free Ball and Check Valve .....	48
Elbows.....	6-8	PF-111 Gate Valve .....	49
Fitting Reducers .....	8	PC-111-LF Gate Valve .....	50
Flanges.....	8-9	PF-113 Gate Valve .....	51
Tees.....	9-10	PC-113-LF Gate Valve .....	52
Unions.....	10	PF-211-Y Globe Valve .....	53
Accessories.....	10	PF-311-Y Angle Valve .....	54
<b>Valves</b> .....	11-65	PC-413-Y-LF Lead-Free Check Valve .....	55
Illustrated Index.....	12-13	PC-480-Y/W-LF .....	56
PC-585HP-LF.....	14	PF-413-Y Check Valve .....	57
PC-585HP-66-LF .....	15	PF-480-Y In-line Lift Check Valve .....	58
TPC-585HP-LF .....	16	PFD-2000 Butterfly Valve.....	59
PC-585HP-LF-HC .....	17	PS-585-70 Ball Valve .....	60
PC-585-70 Ball Valve .....	18	PS-585-70-66 Ball Valve .....	61
PC-585-70-66 Ball Valve .....	19	PS-585-70-HC Ball Valve-Hose Connection w/Cap & Chain ...	62
TPC-585-70 Ball Valve .....	20	PF-221/222-A/B Bronze Y-Strainer.....	63
TPC-585-70-66 Valve .....	21	Handle Options and Accessories .....	64
PC-585-70-HC Ball Valve-Hose Connection w/Cap & Chain .	22	NIB-SEAL® Technical Data .....	65
PC-585-70-66-HC Ball Valve-Hose Connection w/Cap & Chain .	23	NIB-SEAL® Locking Extended Handle Technical Data .....	66
PC-585-80-LF Lead-Free Ball Valve.....	24	Butterfly Valve Options and Accessories .....	67
PC-585-66-LF Lead-Free Ball Valve.....	25	Butterfly Valve Technical Information .....	68
PC-585-80-LF-HC Lead-Free Ball Valve.....	26	<b>Tools and Jaws</b> .....	69-73
PC-585-66-LF-HC Lead-Free Ball Valve .....	27	Standard Pressing Tool - PC-280 32kN .....	70
TPC-585-80-LF Ball Valve .....	28	Mini Pressing Tool - PC-20M 15kN .....	71
TPC-585-66-LF Ball Valve .....	29	PC-10M and PC-100 Accessories .....	72
PC-585-80-LF-SR Ball Valve w/Spring Return Handle .....	30	Approved Tool and Jaw Compatibility Matrix .....	73
PC-585-80-LF-HC-SR Ball Valve w/Hose end and		<b>Engineering Data</b> .....	74-77
w/Spring Return Handle.....	31	Copper and Copper Alloy Fittings.....	75
PC-595-Y/R-LF Ball Valve .....	32	Sample Specification - Fittings .....	76
PC-595-Y/R-66-LF Ball Valve .....	33	Sample Specification - Valves.....	77
PC-FP-600A-LF Lead-Free Ball Valve .....	34-35	<b>Installation Instructions</b> .....	78-85
PC-FP-600A-LF-W Lead-Free Ball Valve .....	36	1/2" - 2" Fittings and Valves.....	80-81
PCMT-FP-600A-LF Lead-Free Ball Valve .....	37	2 1/2" - 4" Fitting and Valves.....	82-83
PCT-FP-600A-LF Lead-Free Ball Valve .....	38	Testing Instructions for Leak Detection.....	84
PC-FP-600A-D-LF Lead-Free Ball Valve .....	39	Miscellaneous Technical Information.....	85
PC-FP-600A-LF-HC Lead-Free Ball Valve .....	40	<b>Frequently Asked Questions</b> .....	86
PCPXA-FP-600A-LF Lead-Free Ball Valve .....	41	<b>Press System Warranty</b> .....	87
PCPX-FP-600A-LF Lead-Free Ball Valve .....	42		

LEAD-FREE: Weighted average lead content ≤ 0.25%

# NIBCO presssystem<sup>®</sup>

EXPERIENCE THE CONNECTION<sup>®</sup>

## Quick and Easy

NIBCO Press System is user friendly, quick and easy to install. Installation can be completed in less time than traditional solder, threaded, brazed or grooved copper systems. Significant time savings means tight budgets and deadlines are met while project delays and cost overruns are avoided.

## Full System Product Offering

NIBCO Press System is more than just 1/2" to 4" fittings. Our offering also includes the industry's widest and most specified range of ball, gate, globe, angle, check and butterfly valves in addition to a full line of NIBCO tools necessary to complete a total system installation.

## Flameless

NIBCO Press System is easier and safer to use because there is no flame, solder or flux required. Connections can even be made on a wet tube!

## Reliable

With the NIBCO Press System, a watertight joint is formed between the EPDM seal and the crimped fitting or valve providing a permanent connection. Reliability you can count on ... NIBCO press fittings are backed by a 5th generation and a 50-year written guarantee.

## Approvals, Standards and Performance

NIBCO Press System has undergone extensive and rigorous internal and external testing and meets various worldwide, industry and governmental standards and codes. Compliant with the following except where otherwise noted: ASME B16.51 Performance • International Residential Code<sup>®</sup> (IRC) • International Plumbing Code<sup>®</sup> (IPC) • International Mechanical Code<sup>®</sup> (IMC) • Uniform Plumbing Code\* (UPC) • Uniform Mechanical Code\* (UMC) • State of Massachusetts (Plumbing).

\*Uniform Plumbing Code and Uniform Mechanical Code are copyrighted publications of the International Association of Plumbing and Mechanical Officials.

Third-party certified to: IAPMO/ANSI/CAN Z1117, Press Fittings; ICC-ES LC1002, Press-Connection Fittings for Potable Water Tube and Radiant Heating Systems; ASME B16.51, Copper and Copper Alloy Press-Connect Pressure Fittings; NSF/ANSI/CAN 61, Drinking Water System Components—Health Effects; NSF/ANSI/CAN 372, Drinking Water System Components—Lead Content.

All valves and fittings are manufactured under a Quality Management System conforming to the current version of ISO 9001 standards.

## Applications

NIBCO Press System can be used in new construction or repair work and is designed for potable water, HVAC and process water systems for commercial, industrial and residential applications.

## Professional Appearance

NIBCO Press System creates a clean joint without the mess of excess solder or discoloration.

## Joint Integrity

NIBCO Press System uses engineered tools, jaws and chains that are tested and approved to ensure a consistent, reliable crimp.

Visit our website for the most current information.

# **NIBCO**<sup>®</sup> **press**system Fittings

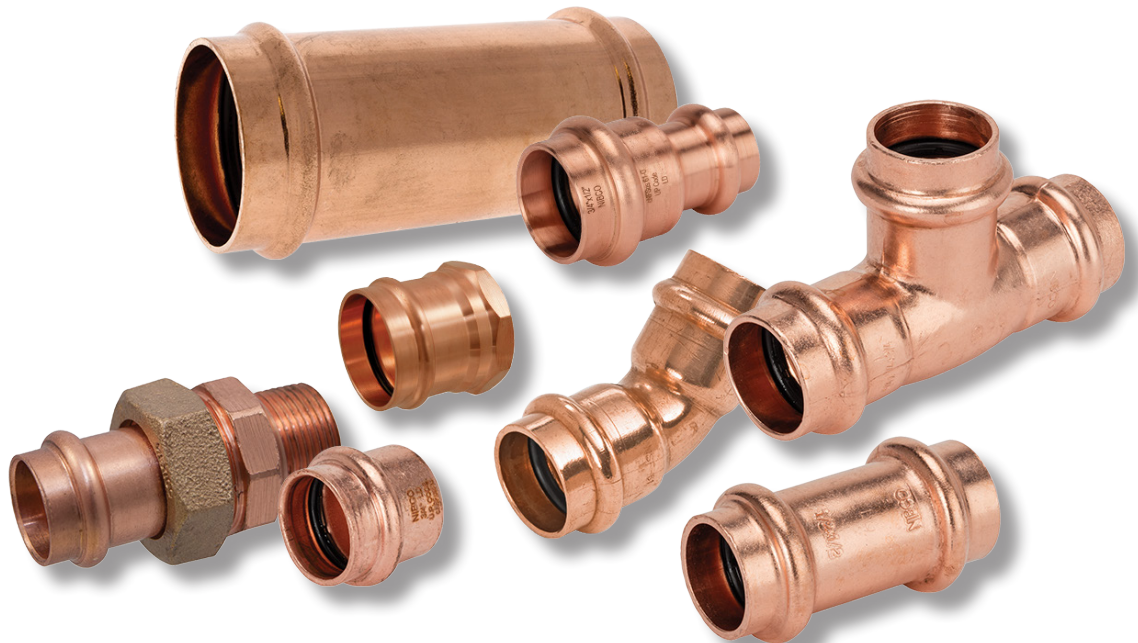

# Press Fitting Applications Chart

Types of Service	Comments	Pressure	Temperature	Compatible with EPDM Seal
<b>Fluids/Water</b>				
Hot and Cold Potable Water		200 psi	32°F to 250°F	●
Rainwater/Gray Water	Subject to local codes/authority having jurisdiction with appropriate precautions to prevent systems from freezing Propylene Glycol	200 psi	-20°F to 250°F	●
Chilled Water	Up to 50% Ethylene Glycol/Propylene Glycol solution appropriate for the application temperature range	200 psi	-20°F to 250°F	●
Hydronic Heating		200 psi	-20°F to 250°F	●
Cooling Water		200 psi	-20°F to 250°F	●
Ethanol		200 psi	-20°F to 250°F	●

<b>Gasses</b>				
Compressed Air	Less than 25mg/m <sup>3</sup> Oil Content	200 psi	Up to 140°F	●
Oxygen - O <sub>2</sub> (non-medical)	Keep Oil and Fat Free/Non-Liquid O <sub>2</sub>	140 psi	Up to 140°F	●
Nitrogen - N <sub>2</sub>		200 psi	Up to 140°F	●
Argon	Welding Use	200 psi	Ambient	●
Hydrogen - H <sub>2</sub>		125 psi	Up to 250°F	●
Vacuum		Max 29.2 in. of Mercury-Hg	Up to 140°F	●
Carbon Dioxide - CO <sub>2</sub>	Dry	200 psi	Up to 140°F	●
Low Pressure Steam		15 psi	Up to 250°F	●

Consult the latest edition of the NIBCO Chem-Guide for general chemical compatibility reference.

Visit our website for the most current information.

## ADAPTERS

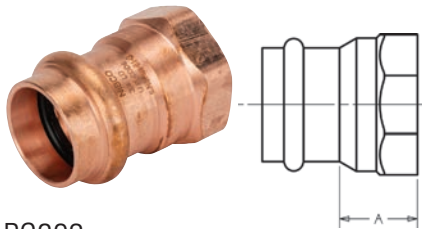

**PC603**  
Adapter P x F – Wrot

NOM. SIZE	APPROX. NET WT./LBS.	DIM. A INCHES
1/2	.103	13/16
1/2 x 3/8	.081	21/32
1/2 x 3/4	.151	31/32
3/4	.158	27/32
3/4 x 1/2	.153	25/32
1	.237	15/16
1 x 1/2	.172	3/4
1 x 3/4	.217	13/16
1 x 1 1/4	.436	13/16
1 1/4	.372	1 1/16
1 1/4 x 1	.359	1 1/16
1 1/4 x 1 1/2	.425	1 7/32
1 1/2	.518	1 1/16
1 1/4 x 2	.276	1
1 1/2 x 1 1/4	.515	1
2	.672	1
2 1/2	1.222	1 13/32
3	1.756	1 23/32
4	3.238	1 7/8

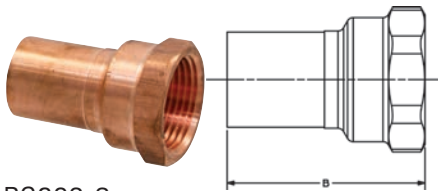

**PC603-2**  
Extended Adapter FTG x F – Wrot

NOM. SIZE	APPROX. NET WT./LBS.	DIM. B INCHES
1/2 x 3/8	0.064	1 17/32
1/2	0.096	1 3/4
1/2 x 3/4	0.132	1 27/32
3/4 x 1/2	0.107	1 25/32
3/4	0.145	1 7/8
1 x 1/2	0.146	2
1	0.220	2 1/16
1 1/4 x 1/2	0.193	2 3/16
1 1/4	0.322	2 3/8
1 1/2	0.431	2 21/32
2	0.683	2 15/16

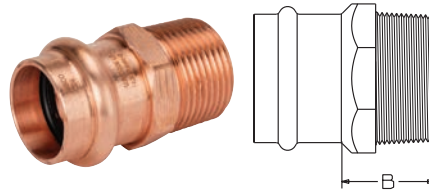

**PC604**  
Adapter P x M – Wrot

NOM. SIZE	APPROX. NET WT./LBS.	DIM. B INCHES
1/2	.103	7/8
1/2 x 3/8	.105	27/32
1/2 x 3/4	.191	1 1/4
3/4	.180	1 1/16
3/4 x 1/2	.189	31/32
3/4 x 1	.268	1 3/16
1	.255	1 3/32
1 x 3/4	.253	1 1/32
1 x 1 1/4	.457	1 17/32
1 1/4	.467	1 13/32
1 1/4 x 1	.335	1 3/16
1 1/4 x 1 1/2	.537	1 1/2
1 1/2	.696	1 1/2
1 1/2 x 1 1/4	.603	1 3/8
1 1/2 x 2	.784	1 7/16
2	.856	1 7/16
2 x 1 1/2	1.087	1 19/32
2 1/2	1.322	1 27/32
3	2.104	2 1/8
4	3.298	2 9/32

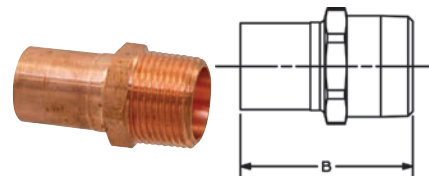

**PC604-2**  
Extended Adapter FTG x M – Wrot

NOM. SIZE	APPROX. NET WT./LBS.	DIM. B INCHES
1/2 x 3/8	0.056	1 3/4
1/2	0.101	1 29/32
1/2 x 3/4	0.145	2 1/16
3/4 x 1/2	0.100	1 15/16
3/4	0.136	2 1/16
1 x 3/4	0.175	2 1/16
1	0.243	2 5/16
1 1/4	0.408	2 17/32
1 1/2	0.530	2 7/8
2	0.782	3 11/32

## ADAPTERS (Cont.)

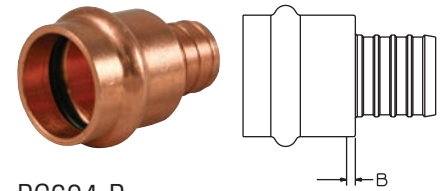

**PC604-P**  
Adapter PEX x P – Wrot

NOM. SIZE	APPROX. NET WT./LBS.	DIM. B INCHES
1/2 x 1/2	.055	1/8
1/2 x 3/4	.108	7/32
3/4 x 1/2	.057	3/32
3/4 x 3/4	.108	5/32
1 x 1	.148	5/32

## CAPS

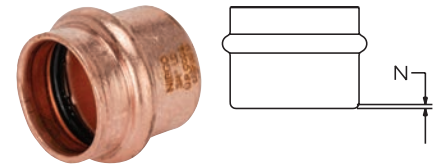

**PC617**  
Cap P – Wrot

NOM. SIZE	APPROX. NET WT./LBS.	DIM. N INCHES
1/2	.046	5/32
3/4	.087	5/32
1	.125	1/8
1 1/4	.171	3/32
1 1/2	.314	3/32
2	.493	3/32
2 1/2	.476	7/32
3	.713	7/32
4	1.491	1/4

Visit our website for the most current information.

## COUPLINGS

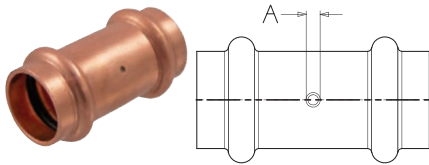

PC600-DS  
Coupling P x P – Wrot

NOM. SIZE	APPROX. NET WT./LBS.	DIM. A INCHES
1/2	.083	3/16
3/4	.157	5/32
1	.198	5/32
1¼	.271	5/32
1½	.530	3/16
2	.691	5/32
2½	.669	1/8
3	.979	1/8
4	2.134	7/32

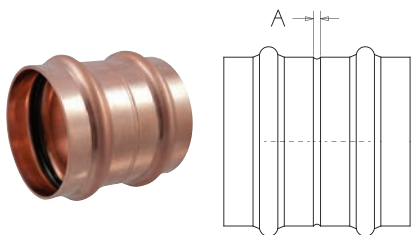

PC600-RS  
Coupling P x P – Wrot

NOM. SIZE	APPROX. NET WT./LBS.	DIM. A INCHES
2½	.688	1/8
3	.979	1/8
4	2.134	7/32

## COUPLINGS (Cont.)

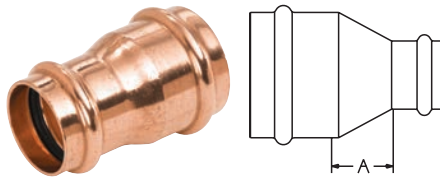

PC600-R  
Reducing Coupling P x P – Wrot

NOM. SIZE	APPROX. NET WT./LBS.	DIM. A INCHES
3/4 x 1/2	.121	1/4
1 x 1/2	.139	7/16
1 x 3/4	.184	13/32
1¼ x 3/4	.245	1/2
1¼ x 1	.231	7/16
1½ x 3/4	.382	15/32
1½ x 1	.370	13/32
1½ x 1¼	.399	9/32
2 x 3/4	.516	29/32
2 x 1	.552	11/16
2 x 1¼	.570	11/16
2 x 1½	.662	7/16
2½ x 1	.620	31/32
2½ x 1¼	.644	1
2½ x 1½	.678	23/32
2½ x 2	.699	11/32
3 x 1½	.956	1 1/16
3 x 2	1.032	23/32
3 x 2½	.951	1/2
4 x 2	1.949	1 5/32
4 x 2½	1.807	1
4 x 3	1.960	27/32

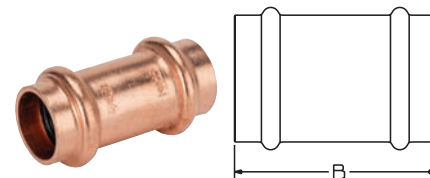

PC601 (No Stop)  
Repair Coupling P x P – Wrot

NOM. SIZE	APPROX. NET WT./LBS.	DIM. B INCHES
1/2	.082	1 3/4
3/4	.157	2 1/4
1	.190	2 1/4
1¼	.271	2 15/32
1½	.511	3 11/32
2	.691	3 5/8
2½	.669	2 15/16
3	.979	3 5/16
4	1.878	4 5/16

## COUPLINGS (Cont.)

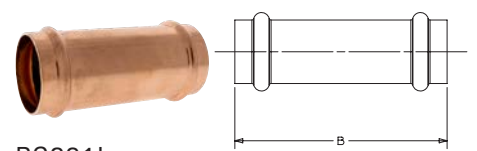

PC601L  
Extended Repair Coupling P x P

NOM. SIZE	APPROX. NET WT./LBS.	DIM. B INCHES
1/2	.1250	2 29/32
3/4	.2200	3 9/32
1	.3050	3 21/32
1¼	.4090	4 1/16
1½	.7150	4 21/32
2	1.0230	5 1/4

## ELBOWS

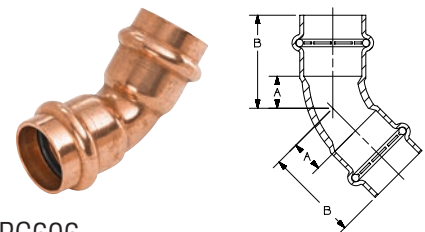

PC606  
45° Elbow P x P – Wrot

NOM. SIZE	APPROX. NET WT./LBS.	DIM. A INCHES	DIM. B INCHES
1/2	.092	13/32	1 1/8
3/4	.181	1/2	1 13/32
1	.251	5/8	1 1/2
1¼	.403	25/32	1 25/32
1½	.666	15/16	2 5/16
2	1.063	13/16	2 23/32
2½	1.041	7/8	2 3/8
3	1.536	1 1/8	2 25/32
4	3.375	1 11/16	3 27/32

Visit our website for the most current information.

**ELBOWS (Cont.)**

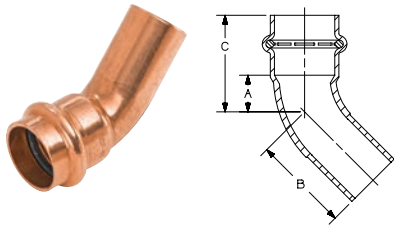

**PC606-2**  
45° Elbow Ftg x P – Wrot

NOM. SIZE	APPROX. NET WT. LBS.	DIMENSIONS INCHES		
		A	B	C
1/2	.094	7/16	1 5/16	1 1/8
3/4	.171	17/32	1 13/32	1 13/32
1	.248	9/16	1 17/32	1 7/16
1 1/4	.368	1 1/16	1 3/4	1 11/16
1 1/2	.673	1 13/16	2 5/16	2 3/16
2	1.057	1	2 21/32	2 1/2
2 1/2	1.050	2 9/32	2 3/16	2 3/8
3	1.526	1 5/32	2 19/32	2 13/16
4	3.284	1 17/32	3 3/32	3 11/16

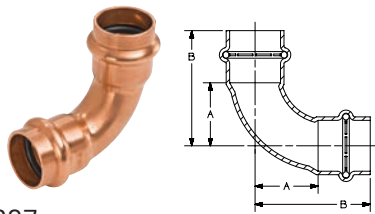

**PC607**  
90° Elbow P x P – Wrot

NOM. SIZE	APPROX. NET WT./LBS.	DIM. A INCHES	DIM. B INCHES
3/4	.223	1 3/32	2
3/4 x 1/2	.201	1 5/32	2
1	.331	1 15/32	2 11/32
1 x 3/4	.321	1 5/16	2 5/16
1 1/4	.528	1 27/32	2 29/32
1 1/2	.895	2 7/32	3 21/32
2	1.480	2 15/16	4 15/32
2 1/2	1.224	1 5/8	3 3/32
3	1.900	2	3 21/32
4	3.935	2 15/32	4 5/8

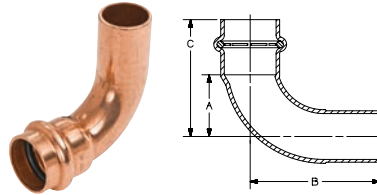

**PC607-2**  
90° Elbow Ftg x P – Wrot

NOM. SIZE	APPROX. NET WT. LBS.	DIMENSIONS INCHES		
		A	B	C
1/2	.110	2 5/32	1 21/32	1 15/32
3/4	.219	1 1/16	2 7/32	1 31/32
1	.328	1 1/2	2 5/8	2 3/8
1 1/4	.490	1 7/8	3 3/32	2 29/32
1 1/2	.871	2 7/32	3 15/16	3 11/16
2	1.474	2 29/32	4 17/32	4 15/32
2 1/2	1.356	1 19/32	3 7/32	3 1/16
3	2.065	2	3 13/16	3 21/32
4	3.920	2 15/32	4 3/4	4 5/8

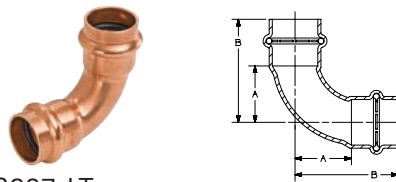

**PC607-LT**  
90° Long Radius Elbow  
P x P – Wrot

NOM. SIZE	APPROX. NET WT./LBS.	DIM. A INCHES	DIM. B INCHES
3	2.810	4 1/32	5 11/16
4	5.696	5 1/4	7 13/32

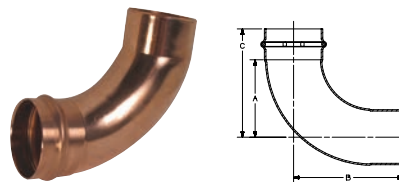

**PC607-2-LT**  
90° Long Radius Elbow  
Ftg x P - Wrot

NOM. SIZE	APPROX. NET WT. LBS.	DIMENSIONS INCHES		
		A	B	C
2 1/2	2.114	3 11/16	5 7/32	5 5/32
3	3.037	4 1/32	5 3/4	5 11/16

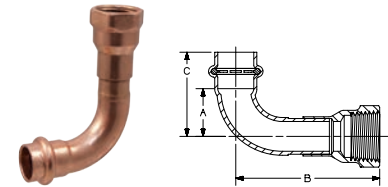

**PC607-3**  
90° Elbow P x F - Wrot

NOM. SIZE	APPROX. NET WT. LBS.	DIMENSIONS INCHES		
		A	B	C
1/2	.191	2 5/32	2 17/32	1 15/32
1/2 x 3/8	.154	2 5/32	2 7/32	1 15/32
1/2 x 3/4	.251	2 5/32	2 11/16	1 15/32
3/4	.361	1 1/16	3 1/8	2
3/4 x 1/2	.321	1 1/16	2 27/32	2
1	.513	1 1/16	3 15/32	2 5/16
1 1/4	.892	1 27/32	4 3/16	2 29/32
1 1/2	1.314	2 7/32	5 1/16	3 11/16
2	2.109	2 29/32	5 5/8	4 15/32

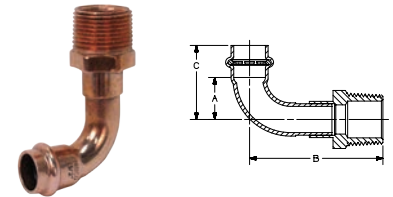

**PC607-4**  
90° Elbow P x M - Wrot

NOM. SIZE	APPROX. NET WT. LBS.	DIMENSIONS INCHES		
		A	B	C
1/2	.183	2 5/32	2 9/32	1 15/32
1/2 x 3/4	.340	2 5/32	2 21/32	1 15/32
3/4	.349	1 1/16	3 1/32	2
3/4 x 1/2	.340	1 1/16	3 1/16	2
1	.521	1 7/16	3 13/32	2 5/16
1 1/4	.926	1 27/32	4 1/32	2 29/32
1 1/2	1.443	2 7/32	4 15/16	3 11/16
2	2.205	2 29/32	5 5/8	4 15/32

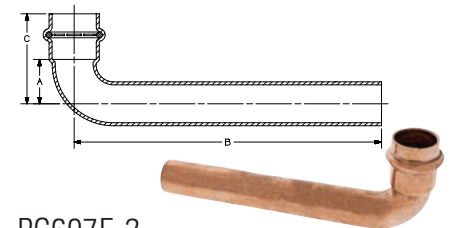

**PC607E-2**  
Extended Elbow P x FTG – Wrot

NOM. SIZE	APPROX. NET WT. LBS.	DIMENSIONS INCHES		
		A	B	C
3/4	.407	2 9/32	6 1/8	1 25/32

Visit our website for the most current information.

**ELBOWS (Cont.)**

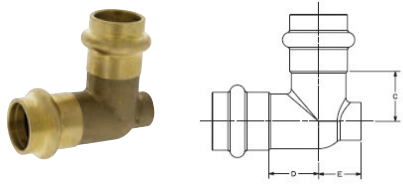

**PC705-D**  
Vent Elbow P x P – Forged Brass

NOM. SIZE	APPROX. NET WT. LBS.	DIMENSIONS INCHES		
		C	D	E
1/2	.010	19/32	19/32	9/16
3/4	.010	3/4	3/4	11/16



**PC605**  
Stiffener – Wrot

NOM. SIZE	APPROX. NET WT. LBS.
3/4	.043

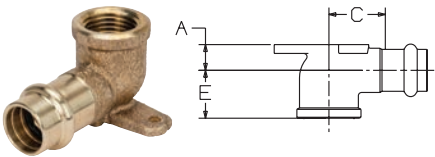

**PC707-3-5-LF**  
90° Drop Elbow P x F – Cast  
\*Lead Free

NOM. SIZE	APPROX. NET WT. LBS.	DIMENSIONS INCHES		
		A	C	E
1/2	.252	17/32	7/8	27/32
3/4	.588	23/32	1 5/8	31/32

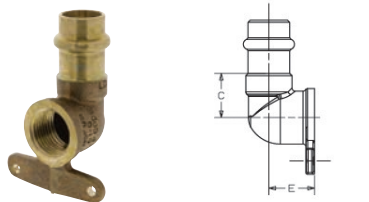

**PC707-3-5-A**  
Hi-Ear Elbow P x F – Cast \*Lead Free

NOM. SIZE	APPROX. NET WT./LBS.	DIM. C INCHES	DIM. E INCHES
1/2	.192	7/8	27/32

Visit our website for the most current information.

**FITTING REDUCERS**

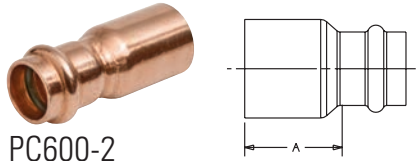

**PC600-2**  
Fitting Reducer Ftg x P – Wrot

NOM. SIZE	APPROX. NET WT./LBS.	DIM. A INCHES
1/2	.610	2 1/32
3/4 x 1/2	.092	1 7/16
3/4	.126	3 1/32
1 x 1/2	.123	1 7/16
1 x 3/4	.151	1 13/32
1	.162	1 1/8
1 1/4 x 1/2	.155	1 19/32
1 1/4 x 3/4	.175	1 13/32
1 1/4 x 1	.181	1 7/16
1 1/4	.215	1 3/16
1 1/2 x 1/2	.243	2 3/32
1 1/2 x 3/4	.248	1 31/32
1 1/2 x 1	.251	1 13/16
1 1/2 x 1 1/4	.251	1 25/32
1 1/2	.382	1 5/16
2 x 1/2	.394	2 1/2
2 x 3/4	.405	2 11/32
2 x 1	.398	2 7/32
2 x 1 1/4	.420	2 3/32
2 x 1 1/2	.507	1 31/32
2	.619	1 9/16
2 1/2 x 3/4	.540	2 1/2
2 1/2 x 1	.707	2 1/2
2 1/2 x 1 1/4	.776	2 9/16
2 1/2 x 1 1/2	.840	2 13/32
2 1/2 x 2	.839	2
3 x 3/4	.755	2 29/32
3 x 1 1/4	.882	2 13/16
3 x 1 1/2	1.055	2 13/16
3 x 2	1.084	2 3/8
4 x 3/4	1.723	4 3/32
4 x 2	1.832	3 5/8
4 x 2 1/2	1.837	3 1/32
4 x 3	2.013	3 1/32

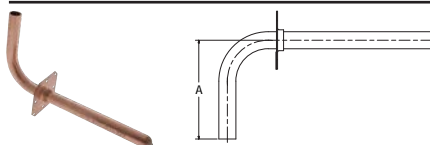

**PC607-2EW** Stub-Out F x S

NOM. SIZE	APPROX. NET WT./LBS.	DIM. A INCHES
1/2	.360	3 5/8
3/4	.520	3 15/16
1	.740	6 1/16

**FLANGES**

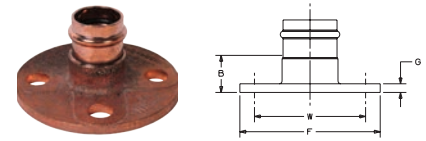

**PC741** ⚠️  
Companion Flange  
P x Flange - Cast Bronze Flange/  
Wrot Outlet

NOM. SIZE	APPROX. NET WT. LBS.	DIMENSIONS INCHES			
		B	F	G	W
1	1.428	1 1/4	4 1/4	1/4	3 1/8
1 1/4	1.632	1 5/16	4 5/8	1/4	3 1/2
1 1/2	2.186	1 7/16	5	5/16	3 7/8
2	3.352	1 11/16	6	3/8	4 3/4

**NOTE:** Maximum pressure 105 psi CWVP, 90 psi at 250°F. Use in U.S. drinking water applications is prohibited after January 3, 2014.

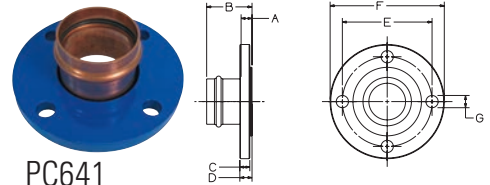

**PC641**  
Companion Flange  
P x Flange - Wrot

NOM. SIZE	APPROX. NET WT. LBS.	DIMENSIONS INCHES		
		A	B	C
3/4	1.518	2 1/32	2 17/32	7/16
1	2.013	2 23/32	2 19/32	1/2
1 1/4	2.623	2 1/32	2 21/32	9/16
1 1/2	3.342	1 1/2	2 7/8	5/8
2	4.884	1 15/32	2 11/32	5/8
2 1/2	6.418	3/4	2 25/32	5/8
3	7.409	15/32	2 15/16	2 1/32
4	10.920	2 1/32	3 3/8	2 3/32

NOM. SIZE	DIMENSIONS INCHES			
	D	E	F	G
3/4	9/16	2 3/4	3 7/8	5/8
1	5/8	3 1/8	4 1/4	5/8
1 1/4	1 1/16	3 1/2	4 5/8	5/8
1 1/2	2 5/32	3 7/8	5	5/8
2	2 5/32	4 3/4	6	3/4
2 1/2	3/4	5 1/2	7	3/4
3	1 13/16	6	7 1/2	3/4
4	1	7 1/2	9	3/4

**NOTE:** 4" requires (8) "G" holes equally spaced.  
**NOTE:** Mates with ANSI Class 125/150 flanges.

**⚠️ WARNING:** This product can expose you to chemicals including lead, which is known to the State of California to cause cancer and birth defects or other reproductive harm. For more information go to [www.P65Warnings.ca.gov](http://www.P65Warnings.ca.gov).  
LEAD-FREE: Weighted average lead content ≤ 0.25%

**FLANGES (Cont.)**

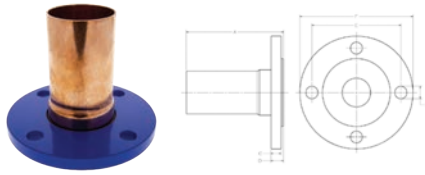

PC672-2  
Companion Flange  
FTG x Flange – Wrot

NOM. SIZE	APPROX. NET WT. LBS.	A	DIMENSIONS INCHES C D	
2	5.46	6	5/8	25/32
2½	7.44	6	5/8	25/32
3	8.63	6	5/8	25/32
4	12.03	6	23/32	7/8

NOM. SIZE	DIMENSIONS INCHES E F G		
2	4 ¾	6	¾
2½	5 ½	7	¾
3	6	7 ½	¾
4	7 ½	9	¾

**TEES**

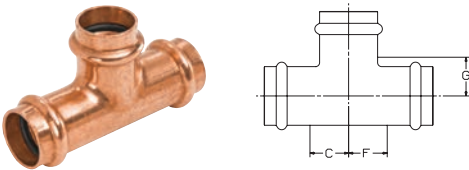

PC611  
Tee P x P x P – Wrot

NOM. SIZE	APPROX. NET WT. LBS.	DIMENSIONS INCHES C F G		
1/2	.176	23/32	23/32	15/32
1/2 x 1/2 x 3/4	.314	2 1/16	2 1/16	15/16
1/2 x 1/2 x 1	.491	17/32	17/32	7/8
3/4	.320	25/32	25/32	21/32
3/4 x 1/2 x 1/2	.281	5/8	29/32	21/32
3/4 x 1/2 x 3/4	.320	21/32	1 1/16	1 1/16
3/4 x 3/4 x 1/2	.276	21/32	21/32	21/32
3/4 x 3/4 x 1	.461	1 1/32	1 1/32	29/32
1	.501	7/8	7/8	29/32
1 x 1/2 x 3/4	.400	23/32	1 1/4	27/32
1 x 1/2 x 1	.513	13/16	1 5/32	27/32
1 x 3/4 x 1/2	.440	13/16	1 1/16	1 5/32
1 x 3/4 x 3/4	.459	25/32	31/32	13/16

**TEES (Cont.)**

NOM. SIZE	APPROX. NET WT. LBS.	DIMENSIONS INCHES C F G		
1 x 3/4 x 1	.578	13/16	1 1/16	7/8
1 x 1 x 1/2	.324	21/32	21/32	7/8
1 x 1 x 3/4	.388	3/4	3/4	27/32
1 x 1 x 1 ¼	.723	1 1/8	1 1/8	7/8
1 ¼	.759	1	1	15/16
1 ¼ x 1/2 x 1 ¼	.690	31/32	1 17/32	31/32
1 ¼ x 1 x 1/2	.674	31/32	1 5/32	1 5/8
1 ¼ x 3/4 x 1/2	.682	15/16	1 9/32	1 5/8
1 ¼ x 3/4 x 3/4	.565	3/4	1 7/32	1 1/32
1 ¼ x 3/4 x 1	.709	31/32	1 1/4	1 5/16
1 ¼ x 3/4 x 1 ¼	.698	31/32	1 9/32	1 5/16
1 ¼ x 1 x 3/4	.753	27/32	1 3/16	1 13/32
1 ¼ x 1 x 1	.725	31/32	1 7/32	1 9/32
1 ¼ x 1 ¼ x 1/2	.408	1	1	1 17/32
1 ¼ x 1 ¼ x 3/4	.589	23/32	23/32	1 5/16
1 ¼ x 1 ¼ x 1	.508	7/8	7/8	31/32
1 ½	1.179	1 5/16	1 5/16	1 3/32
1 ½ x 1/2 x 1 ½	1.263	29/32	2 29/32	1
1 ½ x 3/4 x 3/4	1.101	29/32	1 13/16	1 3/4
1 ½ x 1 x 3/4	1.217	1 5/16	1 3/4	1 13/16
1 ½ x 1 x 1	1.105	1 3/16	1 11/16	1 19/32
1 ½ x 1 x 1 ½	1.146	27/32	2 1/32	1 1/8
1 ½ x 1 ¼ x 3/4	1.164	31/32	1 5/8	1 7/8
1 ½ x 1 ¼ x 1	1.105	7/8	1 19/32	1 5/8
1 ½ x 1 ¼ x 1 ¼	1.160	1 5/16	1 9/16	1 19/32
1 ½ x 1 ½ x 1/2	.639	3/8	3/8	1 1/8
1 ½ x 1 ½ x 3/4	.740	19/32	19/32	1 3/32
1 ½ x 1 ½ x 1	.785	1 1/16	1 1/16	1 3/16
1 ½ x 1 ½ x 1 ¼	1.262	7/8	7/8	1 19/32
2	1.771	1 13/32	1 13/32	1 13/32
2 x 1/2 x 2	1.663	1 13/32	2 1/2	1 7/16
2 x 1 x 1	1.764	1 13/32	2 1/4	2 7/32
2 x 1 x 2	1.564	1 13/32	2 5/32	1 13/32
2 x 1 ¼ x 1 ¼	1.471	1 11/32	2 1/16	2 1/8
2 x 1 ½ x 3/4	1.542	1 11/32	2 29/32	2 1/4
2 x 1 ½ x 1	1.546	1 3/8	2 29/32	2 1/4
2 x 1 ½ x 1 ¼	1.543	1 3/8	2 29/32	2 5/32
2 x 1 ½ x 1 ½	1.670	1 1/8	1 9/16	1 13/32
2 x 1 ½ x 2	1.787	1 5/32	1 11/16	1 1/2
2 x 2 x 1/2	1.576	1 3/8	1 3/8	2 7/16
2 x 2 x 3/4	1.256	3/4	3/4	1 1/2
2 x 2 x 1	1.530	29/32	2 29/32	1 11/16
2 x 2 x 1 ¼	1.576	1 3/8	1 3/8	2 1/8
2 x 2 x 1 ½	1.770	1 1/8	1 1/8	1 1/2
2 1/2	2.082	1 9/16	1 9/16	1 7/8
2 ½ x 3/4 x 2 ½	2.294	1 21/32	2 7/8	1 13/16
2 ½ x 1 x 2 ½	2.004	1 1/2	2 1/2	1 25/32
2 ½ x 1 ¼ x 2 ½	2.081	1 21/32	2 17/32	1 13/16
2 ½ x 1 ½ x 2 ½	2.973	1 25/32	2 7/16	1 7/8
2 ½ x 1 ½ x 2	3.052	1 15/16	2 7/16	2 3/8

NOM. SIZE	APPROX. NET WT. LBS.	DIMENSIONS INCHES C F G		
2 ½ x 2 x 3/4	2.934	1 13/16	1 31/32	2 15/16
2 ½ x 2 x 1	2.907	1 27/32	2 1/32	2 3/4
2 ½ x 2 x 1 ¼	2.954	1 11/16	2	2 19/32
2 ½ x 2 x 1 ½	2.976	1 23/32	2	2 15/32
2 ½ x 2 x 2	3.046	1 13/16	1 31/32	2 1/4
2 ½ x 2 x 3	3.580	2 17/32	2 3/4	2 3/8
2 ½ x 2 x 2 ½	2.150	1 13/16	1 31/32	1 7/8
2 ½ x 2 ½ x 1/2	2.117	1 21/32	1 21/32	3 1/4
2 ½ x 2 ½ x 3/4	2.011	1 9/16	1 9/16	2 15/16
2 ½ x 2 ½ x 1	1.644	1 1/2	1 1/2	2 1/2
2 ½ x 2 ½ x 1 ¼	2.075	1 21/32	1 21/32	2 21/32
2 ½ x 2 ½ x 1 ½	2.966	1 27/32	1 27/32	2 1/2
2 ½ x 2 ½ x 2	2.957	1 25/32	1 25/32	2 1/4
3	3.122	1 15/16	1 15/16	2 1/32
3 x 3/4 x 3	3.049	1 7/8	3 1/2	2 3/16
3 x 1 x 3	3.043	1 7/8	3 3/16	2 3/16
3 x 1 ¼ x 3	2.986	1 7/8	2 15/16	2 1/8
3 x 1 ½ x 3	3.811	2 1/32	2 25/32	2 13/32
3 x 2 x 2	3.829	1 31/32	2 1/32	2 3/4
3 x 2 x 2 ½	3.761	2 1/32	2 21/32	2 1/2
3 x 2 x 3	3.866	2	2 21/32	2 3/8
3 x 2 ½ x 2	3.081	1 7/8	2 7/16	2 13/16
3 x 2 ½ x 2 ½	3.010	1 13/16	2 15/32	2 1/2
3 x 2 ½ x 3	3.194	1 13/16	2 15/32	2 3/16
3 x 3 x 1/2	2.301	1 7/8	1 7/8	3 17/32
3 x 3 x 3/4	2.307	1 1/2	1 1/2	3
3 x 3 x 1	2.317	1 1/2	1 1/2	2 3/4
3 x 3 x 1 ¼	2.957	1 7/8	1 7/8	2 15/16
3 x 3 x 1 ½	3.056	1 7/8	1 7/8	2 13/16
3 x 3 x 2	3.145	1 7/8	1 7/8	2 11/16
3 x 3 x 2 ½	3.034	1 15/16	1 15/16	2 1/2
4	7.169	2 13/32	2 13/32	2 17/32
4 x 2 x 4	7.069	2 3/8	3 19/32	2 19/32
4 x 2 ½ x 4	6.984	2 3/8	3 25/32	2 23/32
4 x 3 x 2	6.965	2 3/8	3 9/16	3 25/32
4 x 3 x 2 ½	6.990	2 3/8	3 9/16	3 29/32
4 x 3 x 3	7.085	2 3/8	3 9/16	3 1/2
4 x 3 x 4	6.993	2 3/8	3 23/32	2 23/32
4 x 4 x 1/2	4.328	1 11/32	1 11/32	3 11/32
4 x 4 x 3/4	4.415	1 11/32	1 11/32	3 5/16
4 x 4 x 1	4.414	1 11/32	1 11/32	3 1/8
4 x 4 x 1 ¼	4.730	1 7/16	1 7/16	3 3/32
4 x 4 x 1 ½	7.144	2 11/32	2 11/32	3 31/32
4 x 4 x 2	7.094	2 11/32	2 11/32	3 13/16
4 x 4 x 2 ½	6.925	2 3/8	2 3/8	3 29/32
4 x 4 x 3	7.083	2 3/8	2 3/8	3 1/2

**TEES (Cont.)**

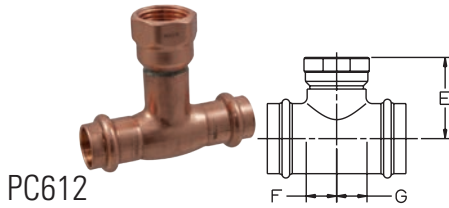

PC612  
Tee P x P x F – Wrot

NOM. SIZE	APPROX. NET WT./LBS.	DIMENSIONS INCHES		
		E	F	G
1/2	.257	1 <sup>31</sup> / <sub>32</sub>	2 <sup>3</sup> / <sub>32</sub>	2 <sup>3</sup> / <sub>32</sub>
3/4	.434	2 <sup>11</sup> / <sub>32</sub>	2 <sup>5</sup> / <sub>32</sub>	2 <sup>5</sup> / <sub>32</sub>
3/4 x 3/4 x 1/4	.385	2 <sup>3</sup> / <sub>32</sub>	2 <sup>3</sup> / <sub>32</sub>	2 <sup>1</sup> / <sub>32</sub>
3/4 x 3/4 x 1/2	.258	2 <sup>5</sup> / <sub>32</sub>	2 <sup>1</sup> / <sub>32</sub>	2 <sup>1</sup> / <sub>32</sub>
1 x 1 x 1/2	.393	2 <sup>1</sup> / <sub>4</sub>	2 <sup>1</sup> / <sub>32</sub>	2 <sup>1</sup> / <sub>32</sub>
1 x 1 x 3/4	.516	2 <sup>27</sup> / <sub>32</sub>	2 <sup>1</sup> / <sub>32</sub>	2 <sup>1</sup> / <sub>32</sub>
1 1/4 x 1 1/4 x 1/2	.494	2 <sup>13</sup> / <sub>32</sub>	5/8	5/8
1 1/4 x 1 1/4 x 3/4	.679	2 <sup>5</sup> / <sub>8</sub>	1 <sup>1</sup> / <sub>16</sub>	1 <sup>1</sup> / <sub>16</sub>
1 1/2 x 1 1/2 x 1/2	.733	2 <sup>11</sup> / <sub>16</sub>	3/8	3/8
1 1/2 x 1 1/2 x 3/4	.885	2 <sup>7</sup> / <sub>8</sub>	1 <sup>9</sup> / <sub>32</sub>	1 <sup>9</sup> / <sub>32</sub>
2 x 2 x 1/2	1.699	3 <sup>27</sup> / <sub>32</sub>	1 <sup>3</sup> / <sub>8</sub>	1 <sup>3</sup> / <sub>8</sub>
2 x 2 x 3/4	1.370	3 <sup>3</sup> / <sub>16</sub>	3/4	3/4
2 1/2 x 2 1/2 x 3/4	1.049	2 <sup>15</sup> / <sub>32</sub>	1 <sup>1</sup> / <sub>16</sub>	1 <sup>1</sup> / <sub>16</sub>
2 1/2 x 2 1/2 x 2	1.925	3 <sup>7</sup> / <sub>32</sub>	1 <sup>9</sup> / <sub>32</sub>	1 <sup>9</sup> / <sub>32</sub>
3 x 3 x 3/4	1.435	2 <sup>3</sup> / <sub>4</sub>	1 <sup>1</sup> / <sub>16</sub>	1 <sup>1</sup> / <sub>16</sub>
3 x 3 x 2	2.097	3 <sup>15</sup> / <sub>32</sub>	2 <sup>1</sup> / <sub>32</sub>	2 <sup>1</sup> / <sub>32</sub>
4 x 4 x 3/4	2.786	3 <sup>1</sup> / <sub>4</sub>	1 <sup>1</sup> / <sub>16</sub>	1 <sup>1</sup> / <sub>16</sub>
4 x 4 x 2	3.675	4	1 <sup>9</sup> / <sub>32</sub>	1 <sup>9</sup> / <sub>32</sub>

**UNIONS**

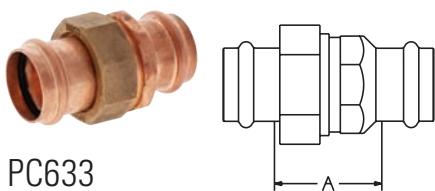

PC633  
Union P x P – Wrot

NOM. SIZE	APPROX. NET WT./LBS.	DIM. A INCHES
1/2	.383	1 <sup>5</sup> / <sub>16</sub>
3/4	.527	1 <sup>9</sup> / <sub>32</sub>
1	.804	1 <sup>11</sup> / <sub>32</sub>
1 1/4	1.107	1 <sup>19</sup> / <sub>32</sub>
1 1/2	1.703	1 <sup>21</sup> / <sub>32</sub>
2	2.368	1 <sup>27</sup> / <sub>32</sub>

**UNIONS (Cont.)**

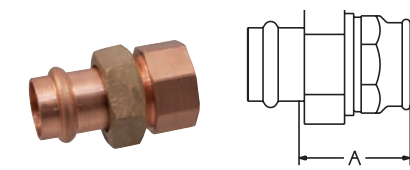

PC633-3 ⚠  
Union P x F – Wrot

NOM. SIZE	APPROX. NET WT./LBS.	DIM. A INCHES
1/2	.374	1 <sup>7</sup> / <sub>16</sub>
3/4	.527	1 <sup>17</sup> / <sub>32</sub>
1	.841	1 <sup>5</sup> / <sub>8</sub>
1 1/4	1.178	1 <sup>15</sup> / <sub>16</sub>
1 1/2	1.610	1 <sup>29</sup> / <sub>32</sub>
2	2.445	2 <sup>5</sup> / <sub>32</sub>

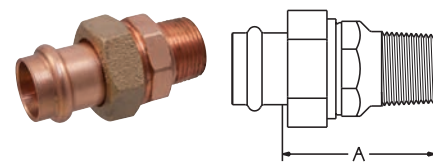

PC633-4 ⚠  
Union P x M – Wrot

NOM. SIZE	APPROX. NET WT./LBS.	DIM. A INCHES
1/2	.386	1 <sup>13</sup> / <sub>16</sub>
3/4	.567	1 <sup>29</sup> / <sub>32</sub>
1	.842	2 <sup>5</sup> / <sub>32</sub>
1 1/4	1.316	2 <sup>3</sup> / <sub>8</sub>
1 1/2	1.756	2 <sup>13</sup> / <sub>32</sub>
2	2.789	2 <sup>3</sup> / <sub>4</sub>

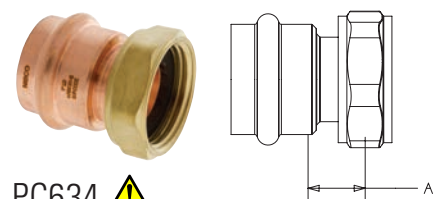

PC634 ⚠  
Tailpiece P x F BSP

NOM. SIZE	APPROX. NET WT./LBS.	DIM. A INCHES
1/2 X 1	0.1840	1 <sup>5</sup> / <sub>32</sub>
3/4 X 1	0.2230	1 <sup>5</sup> / <sub>32</sub>
1 X 1	0.2320	2 <sup>1</sup> / <sub>32</sub>
1 X 1 1/4	0.3530	3/8

**ACCESSORIES**



EPDM Seal (leak detection)

SIZE	PART No.	
1/2	T048352 PP	Leak Detect
3/4	T048354 PP	Leak Detect
1	T048356 PP	Leak Detect
1 1/4	T048358 PP	Leak Detect
1 1/2	T048360 PP	Leak Detect
2	T048362 PP	Leak Detect

NOTE: Do NOT use with PC-FP600A-LF



Large Diameter EPDM Seal (leak detection)

SIZE	PART No.	
2 1/2	T048364 PP	Leak Detect
3	T048366 PP	Leak Detect
4	T048368 PP	Leak Detect



EPDM Seal (leak detection for PC-FP600A-LF ONLY)

SIZE	PART No.	
1/2	T048370 PP	PC-FP600A-LF
3/4	T048372 PP	PC-FP600A-LF
1	T048374 PP	PC-FP600A-LF
1 1/4	T048376 PP	PC-FP600A-LF
1 1/2	T048378 PP	PC-FP600A-LF
2	T048380 PP	PC-FP600A-LF



Press Installation Gauge

SIZE	PART No.
1 1/2 - 2	K700001PC

**⚠ WARNING:** This product can expose you to chemicals including lead, which is known to the State of California to cause cancer and birth defects or other reproductive harm. For more information go to [www.P65Warnings.ca.gov](http://www.P65Warnings.ca.gov).

Visit our website for the most current information.

LEAD-FREE: Weighted average lead content ≤ 0.25%

# NIBCO® pressystem Valves

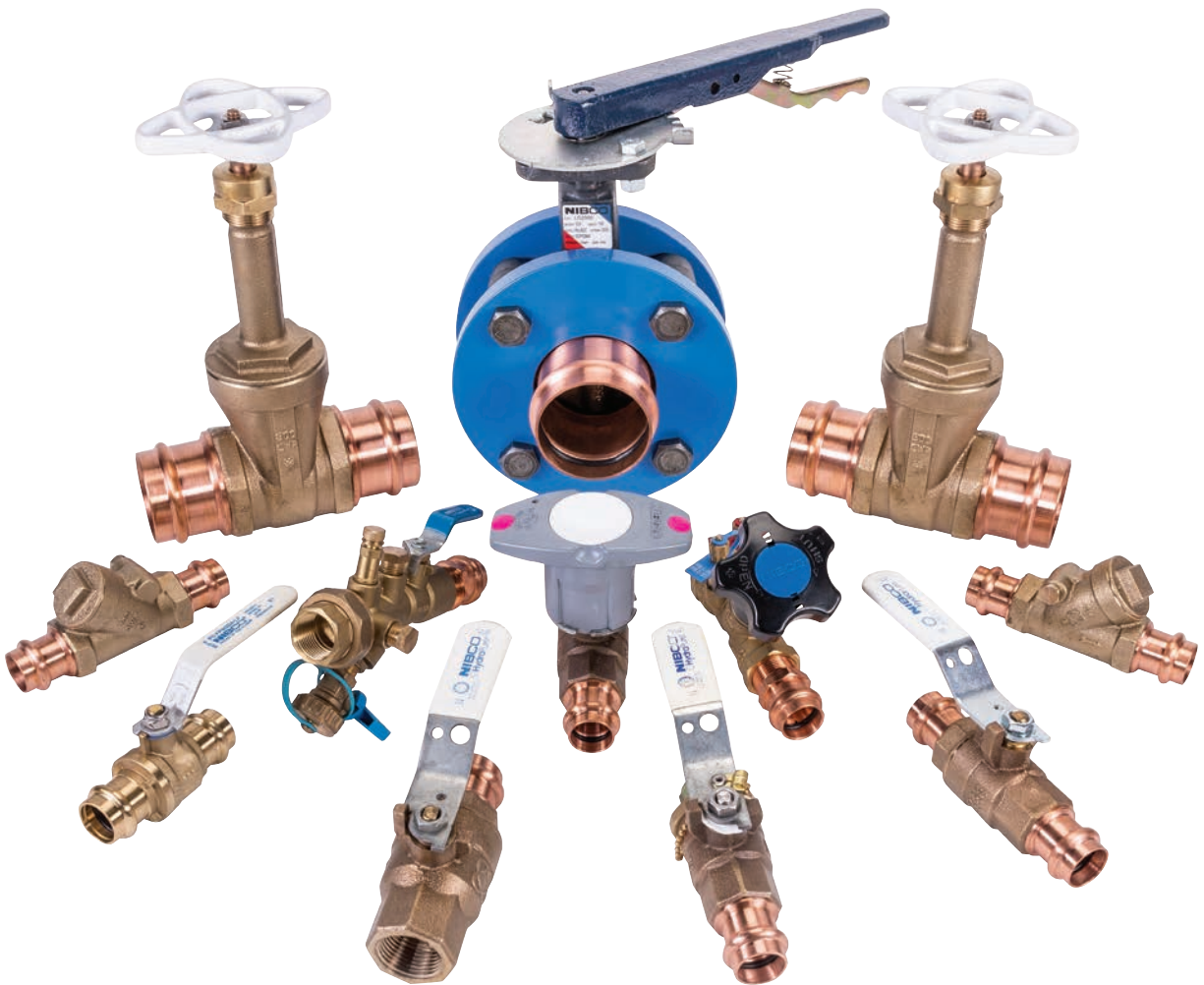

# NIBCO® Press System Illustrated Valve Index

<p><b>PC-585HP-LF and PC-585HP-66-LF</b> Lead-Free Bronze Ball Valve</p>  <ul style="list-style-type: none"> <li>• Two-piece Body</li> <li>• Full Port, 250 psi CWP</li> <li>• Copper Press End w/ Leak Detection</li> <li>• Reversible Handle, Triple-sealed Stem</li> <li>• Sizes 1/2" thru 4"</li> </ul> <p>Page 14, 15</p>	<p><b>TPC-585HP-LF</b> Lead-Free Bronze Ball Valve</p>  <ul style="list-style-type: none"> <li>• Two-piece Body</li> <li>• Full Port, 250 psi CWP</li> <li>• Copper Press End x Threaded</li> <li>• Reversible Handle, Triple-sealed Stem</li> <li>• Sizes 1/2" thru 2"</li> </ul> <p>Page 16</p>	<p><b>PC-585HP-LF-HC</b> Lead-Free Bronze Ball Valve</p>  <ul style="list-style-type: none"> <li>• Two-piece Body</li> <li>• Full Port, 250 psi CWP</li> <li>• Copper Press End with Hose Cap</li> <li>• Reversible Handle, Triple-Sealed stem</li> <li>• Sizes 1/2" and 3/4"</li> </ul> <p>Page 17</p>
<p><b>PC-585-70 and PC-585-70-66</b> Bronze Ball Valve</p>  <ul style="list-style-type: none"> <li>• Press x Press Female End</li> <li>• Full Port, Blowout-Proof Stem</li> <li>• Standard Lever Handle</li> <li>• 250 psi CWP</li> <li>• Sizes 1/2" thru 2"</li> </ul> <p>Page 18, 19</p>	<p><b>TPC-585-70 and TPC-585-70-66</b> Bronze Ball Valve</p>  <ul style="list-style-type: none"> <li>• Press Female End x NPT</li> <li>• Full Port, Blowout-Proof Stem</li> <li>• Standard Lever Handle</li> <li>• 250 psi CWP</li> <li>• Sizes 1/2" thru 2"</li> </ul> <p>Page 20, 21</p>	<p><b>PC-585-70-HC and PC-585-70-66-HC</b> Bronze Ball Valve</p>  <ul style="list-style-type: none"> <li>• Press Female End x Hose</li> <li>• Full Port, Blowout-Proof Stem</li> <li>• Standard Lever Handle</li> <li>• Blow Down, End of Line</li> <li>• Hose Cap with Chain</li> <li>• 250 psi CWP</li> <li>• Sizes 1/2" and 3/4"</li> </ul> <p>Page 22, 23</p>
<p><b>PC-585-80-LF and PC-585-66-LF</b> Lead-Free Bronze Ball Valve</p>  <ul style="list-style-type: none"> <li>• Press x Press Female End</li> <li>• Full Port, Blowout-Proof Stem</li> <li>• Standard Lever Handle</li> <li>• 250 psi CWP</li> <li>• Sizes 1/2" thru 3"</li> </ul> <p>Page 24, 25</p>	<p><b>PC-585-80-LF-HC and PC-585-66-LF-HC</b> Lead-Free Bronze Ball Valve</p>  <ul style="list-style-type: none"> <li>• Press Female End x Hose</li> <li>• Full Port, Blowout-Proof Stem</li> <li>• Standard Lever Handle</li> <li>• 250 psi CWP</li> <li>• Sizes 1/2" and 3/4"</li> </ul> <p>Page 26, 27</p>	<p><b>TPC-585-80-LF and TPC-585-66-LF</b> Lead-Free Bronze Ball Valve</p>  <ul style="list-style-type: none"> <li>• Press Female End x NPT</li> <li>• Full Port, Blowout-Proof Stem</li> <li>• 250 psi CWP</li> <li>• Sizes 1/2" thru 2"</li> </ul> <p>Page 28, 29</p>
<p><b>PC-585-80-LF-SR and PC-585-80-LF-HC-SR</b> Lead-Free Bronze Ball Valve</p>  <ul style="list-style-type: none"> <li>• Press x Press</li> <li>• HC: Press x Hose</li> <li>• Full Port, Blowout-Proof Stem</li> <li>• 250 psi CWP</li> <li>• Sizes 1/2" thru 2"</li> <li>• HC: Sizes 1/2" and 3/4"</li> </ul> <p>Page 30, 31</p>	<p><b>PC-595-Y/R-LF and PC-595-Y/R-66-LF</b> Lead-Free Bronze Ball Valve</p>  <ul style="list-style-type: none"> <li>• Three-piece Body</li> <li>• Full Port, Blowout-Proof Stem</li> <li>• Standard and SS Trim</li> <li>• Press End Leak Detection</li> <li>• 250 psi CWP</li> <li>• Sizes 1/2" thru 2½"</li> </ul> <p>Page 32, 33</p>	<p><b>PC-FP-600A-LF</b> Lead-Free DZR Brass Ball Valve</p>  <ul style="list-style-type: none"> <li>• Press x Press Female End</li> <li>• Full Port, Blowout-Proof Stem</li> <li>• Press End Leak Detection</li> <li>• 250 psi CWP</li> <li>• Sizes 1/2" thru 4"</li> </ul> <p>Page 34, 35</p>
<p><b>PC-FP-600A-LF-W</b> Lead-Free DZR Brass Ball Valve</p>  <ul style="list-style-type: none"> <li>• Press x Press with Wing Handle</li> <li>• Press End Leak Detection</li> <li>• Full Port, Blowout-Proof Stem</li> <li>• 250 psi</li> <li>• Sizes 1/2" - 1"</li> </ul> <p>Page 36</p>	<p><b>PCMT-FP-600A-LF</b> Lead-Free DZR Brass Ball Valve</p>  <ul style="list-style-type: none"> <li>• Press x MIP</li> <li>• Press End Leak Detection</li> <li>• Full Port, Blowout-Proof Stem</li> <li>• 250 psi</li> <li>• Sizes 1/2" - 1"</li> </ul> <p>Page 37</p>	<p><b>PCT-FP-600A-LF</b> Lead-Free DZR Brass Ball Valve</p>  <ul style="list-style-type: none"> <li>• Press x FIP</li> <li>• Press End Leak Detection</li> <li>• Full Port, Blowout-Proof Stem</li> <li>• 250 psi</li> <li>• Sizes 1/2" - 1"</li> </ul> <p>Page 38</p>
<p><b>PC-FP-600A-D-LF</b> Lead-Free DZR Brass Ball Valve</p>  <ul style="list-style-type: none"> <li>• Press x Press with Drain/Bleeder</li> <li>• Press End Leak Detection</li> <li>• Full Port, Blowout-Proof Stem</li> <li>• 250 psi</li> <li>• Sizes 1/2" - 1"</li> </ul> <p>Page 39</p>	<p><b>PC-FP-600A-LF-HC</b> Lead-Free DZR Brass Ball Valve</p>  <ul style="list-style-type: none"> <li>• Press x Hose Cap</li> <li>• Press End Leak Detection</li> <li>• Full Port, Blowout-Proof Stem</li> <li>• 250 psi</li> <li>• Sizes 1/2" - 3/4"</li> </ul> <p>Page 40</p>	<p><b>PCPXA-FP-600A-LF</b> Lead-Free DZR Brass Ball Valve</p>  <ul style="list-style-type: none"> <li>• Press x PEX F1960 Cold Expansion</li> <li>• Press End Leak Detection</li> <li>• Full Port, Blowout-Proof Stem</li> <li>• 250 psi</li> <li>• Sizes 1/2" - 2"</li> </ul> <p>Page 41</p>

**NOTE:** Ball valves are down-rated from 600 psi CWP to 250 psi CWP to match the press system.

Visit our website for the most current information.

LEAD-FREE: Weighted average lead content ≤ 0.25%

# NIBCO® Press System Illustrated Valve Index

<p><b>PCPX-FP-600A-LF</b> Lead-Free DZR Brass Ball Valve</p>  <ul style="list-style-type: none"> <li>• Press x PEX F1807 Crimp</li> <li>• Press End Leak Detection</li> <li>• Full Port, Blowout-proof Stem</li> <li>• 250 psi</li> <li>• Sizes 1/2" - 2"</li> </ul> <p>Page 42</p>	<p><b>PCFU-FP-600A-LF</b> Lead-Free DZR Brass Ball Valve</p>  <ul style="list-style-type: none"> <li>• Press x FIP Union</li> <li>• Press End Leak Detection</li> <li>• Full Port, Blowout-proof Stem</li> <li>• 250 psi</li> <li>• Sizes 1/2" - 1"</li> </ul> <p>Page 43</p>	<p><b>PCMU-FP-600A-LF</b> Lead-Free DZR Brass Ball Valve</p>  <ul style="list-style-type: none"> <li>• Press x MIP Union</li> <li>• Press End Leak Detection</li> <li>• Full Port, Blowout-proof Stem</li> <li>• 250 psi</li> <li>• Sizes 1/2" thru 1"</li> </ul> <p>Page 44</p>
<p><b>PCSU-FP-600A-LF</b> Lead-Free DZR Brass Ball Valve</p>  <ul style="list-style-type: none"> <li>• Press x Solder Union</li> <li>• Press End Leak Detection</li> <li>• Full Port, Blowout-Proof Stem</li> <li>• 250 psi</li> <li>• Sizes 1/2" thru 1"</li> </ul> <p>Page 45</p>	<p><b>PCU-FP600A-LF</b> Lead-Free DZR Brass Press Union Ball Valve</p>  <ul style="list-style-type: none"> <li>• Press x Press Union</li> <li>• Press End Leak Detection</li> <li>• Full Port, Blowout-Proof Stem</li> <li>• 250 psi</li> <li>• Sizes 1/2" thru 1"</li> </ul> <p>Page 46</p>	<p><b>PC-FP600A-S-LF</b> Lead-Free DZR Brass Press Slip Ball Valve</p>  <ul style="list-style-type: none"> <li>• Press x Press Slip</li> <li>• Press End Leak Detection</li> <li>• Full Port, Blowout-Proof Stem</li> <li>• 250 psi</li> <li>• Sizes 1/2" thru 1"</li> </ul> <p>Page 47</p>
<p><b>PC-FP485-LF</b> Lead-Free DZR Brass Press Ball &amp; Check Valve</p>  <ul style="list-style-type: none"> <li>• All-in-one Ball &amp; Check (Press x Press)</li> <li>• Press End Leak Detection</li> <li>• Full Port, Blowout-Proof Stem</li> <li>• 250 psi</li> <li>• Sizes 1/2" thru 1 1/2"</li> </ul> <p>Page 48</p>	<p><b>PF-111 and PC-111-LF</b> Bronze and Lead-Free Bronze Gate Valve</p>  <ul style="list-style-type: none"> <li>• Press x Press Female End</li> <li>• Rising Stem</li> <li>• Press End Leak Detection</li> <li>• 250 psi CWP</li> <li>• Sizes 1/2" thru 2" (PF-113)</li> <li>• Sizes 1/2" thru 3"</li> </ul> <p>Page 49, 50</p>	<p><b>PF-113 and PC-113-LF</b> Bronze and Lead-Free Bronze Gate Valve</p>  <ul style="list-style-type: none"> <li>• Press x Press Female End</li> <li>• Non-Rising Stem</li> <li>• Press End Leak Detection</li> <li>• 250 psi CWP</li> <li>• Sizes 1/2" thru 2" (PF-113)</li> <li>• Sizes 1/2" thru 3" (PC-113-LF)</li> </ul> <p>Page 51, 52</p>
<p><b>PF-211-Y</b> Bronze Globe Valve</p>  <ul style="list-style-type: none"> <li>• Press x Press Female End</li> <li>• PTFE Resilient Seat</li> <li>• 200 psi CWP</li> <li>• Sizes 1/2" thru 2"</li> </ul> <p>Page 53</p>	<p><b>PF-311-Y</b> Bronze Angle Valve</p>  <ul style="list-style-type: none"> <li>• Press x Press Female End</li> <li>• PTFE Resilient Seat</li> <li>• 200 psi CWP</li> <li>• Sizes 1/2" thru 2"</li> </ul> <p>Page 54</p>	<p><b>PC-413-Y-LF</b> Bronze Swing Check Valve</p>  <ul style="list-style-type: none"> <li>• Lead-Free</li> <li>• Press x Press Female End</li> <li>• PTFE Seat</li> <li>• 200 psi CWP</li> <li>• Sizes 1/2" thru 2"</li> </ul> <p>Page 55</p>
<p><b>PF-413-Y</b> Bronze Swing Check Valve</p>  <ul style="list-style-type: none"> <li>• Press x Press Female End</li> <li>• PTFE Seat</li> <li>• 200 psi CWP</li> <li>• Sizes 1/2" thru 2"</li> </ul> <p>Page 57</p>	<p><b>PF-480-Y</b> Bronze In-Line Check Valve</p>  <ul style="list-style-type: none"> <li>• Press x Press Female End</li> <li>• PTFE Seat, Stainless Internals</li> <li>• 200 psi CWP</li> <li>• Sizes 1/2" thru 2"</li> </ul> <p>Page 58</p>	<p><b>PFD-2000 Series</b> Ductile Iron Butterfly Valve</p>  <ul style="list-style-type: none"> <li>• Press x Press Female End</li> <li>• Molded-in Liner</li> <li>• Aluminum Bronze Disc</li> <li>• Standard Lever Handle or Gear Operated</li> <li>• 200 psi CWP</li> <li>• Sizes 2 1/2" thru 4"</li> </ul> <p>Page 59</p>
<p><b>PS-585-70</b> <b>PS-585-70-66</b> Bronze Ball Valve</p>  <ul style="list-style-type: none"> <li>• Press x Press Male End</li> <li>• 2" Type L Copper</li> <li>• Full Port, Blowout-Proof Stem</li> <li>• Standard Lever Handle</li> <li>• 600 psi CWP</li> <li>• Sizes 1/2" thru 2"</li> </ul> <p>Page 60, 61</p>	<p><b>PS-585-70-HC</b> Bronze Ball Valve</p>  <ul style="list-style-type: none"> <li>• Press Male x Hose End</li> <li>• 2" Type L Copper</li> <li>• Full Port, Blowout-Proof Stem</li> <li>• Standard Lever Handle</li> <li>• Blown Down, End of Line</li> <li>• Hose Cap with Chain</li> <li>• 600 psi CWP</li> <li>• Sizes 1/2" and 3/4"</li> </ul> <p>Page 62</p>	<p><b>PF-221/222-A/B</b> Bronze Y-Strainer</p>  <ul style="list-style-type: none"> <li>• Press x Press Female End</li> <li>• Tapped cap w/ blow-off plug or solid cap</li> <li>• 20 Mesh SS Screen or SS Perforated Screen</li> <li>• 200 psi CWP</li> <li>• Sizes 1/2" thru 2"</li> </ul> <p>Page 63</p>

**NOTE: Ball valves are down-rated from 600 psi CWP to 250 psi CWP to match the press system.**

**NOTE: Check valves are down-rated from 250 psi CWP to 200 psi CWP to match the press system.**

LEAD-FREE: Weighted average lead content ≤ 0.25%

Visit our website for the most current information.

# NIBCO® 585HP Lead-Free Bronze Ball Valves

**Features:** Silicon Performance Bronze® Alloy • Laser-Welded Cast Body • Triple-Sealed Stem • Reversible Handle • Easily Adjustable Packing Nut • Blowout-Proof Stem • Press Ends Leak Detection

**Approvals:** MSS-SP110/145 • IAPMO/ANSI Z1157 • NSF/ANSI/CAN 61-8 Commercial Hot 180° F • NSF/ANSI/CAN 372 • ICC-ES PMG-1558 • ASME A112.4.14/CSA B125.14

**Pressure/Temperature Rating:**

**PC-585HP (1/2" - 2"):** 250 psi non-shock cold working pressure\*

**PC-585HP (2 1/2" - 4"):** 200 psi non-shock cold working pressure\*

**Maximum pressure/temperature: 225 psi at 250° F\* (1/2" - 2")**

**200 psi at 250° F\* (2 1/2" - 4")**

Lead-free markings: Double oval in body casting, white handle and blue hang tag

United States Patent  
No. 10,234,043 &  
United States Patent  
No. 11,131,403



**PC-585HP-LF**  
Press

MATERIAL LIST	
PART	SPECIFICATION
1. Handle Nut	Carbon Steel, GEOMET® Coated
2. Handle Stop	ASTM A276 S31600 Stainless Steel
3. Stem	ASTM C69300 Lead-free Silicon Bronze
4. Packing	PTFE
5. Packing Nut	ASTM B16 C36000 Brass
6. Stem O-ring (2)	Omonix® EPDM
7. Press End Seal (2)	EPDM - Leak Detection
8. Boss Seal O-ring (2)	EPDM
9. Body	ASTM B584 C87500 DZR Lead-free Silicon Bronze Casting
10. Seats (2)	Reinforced PTFE
11. Ball	ASTM B584 C46500 DZR Lead-free Brass (1/2" - 1") ASTM A276 S31600 or A351 CF8M Stainless Steel (1 1/4" - 4")
12. Body End Piece	ASTM B584 C87500 DZR Lead-free Silicon Bronze Casting
13. Press End Adapter (2)	ASTM B75 Alloy C12200 Wrot Copper
14. Handle	Carbon Steel, GEOMET® Coated, Plastisol Grip

PC-585HP-66-LF with stainless steel trim also available.

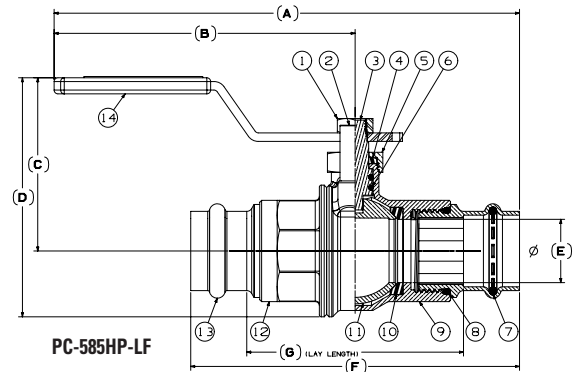

**Handle Options:**

- NIB-SEAL® (1/4" - 2")
- Locking Lever
- Stainless Steel
- Extended Lever w/ Memory Stop

**DIMENSIONS - WEIGHTS**

Size	A		B		C		D		E		F		G		Weights	
In.	In.	mm.	In.	mm.	In.	mm.	In.	mm.	In.	mm.	In.	mm.	In.	mm.	lbs.	kg
1/2"	5.93	151	4.04	103	2.03	52	2.66	68	0.50	13	3.77	96	2.37	60	0.80	0.36
3/4"	6.65	169	4.18	106	2.31	59	3.17	81	0.75	19	4.93	125	3.01	76	1.21	0.55
1"	7.35	187	4.75	121	2.74	70	3.78	96	1.00	25	5.19	132	3.42	87	1.58	0.72
1 1/4"	7.95	202	5.06	129	2.92	74	4.12	105	1.25	32	5.78	147	3.76	96	2.27	1.03
1 1/2"	10.25	260	6.75	171	3.22	82	4.64	118	1.50	38	7.01	178	4.24	108	3.55	1.61
2"	11.03	280	7.12	181	3.68	93	5.46	139	2.00	51	7.80	198	4.78	121	6.26	2.84
2.5"	16.86	428	12.06	306	4.41	112	6.62	168	2.50	63	9.61	244	6.67	169	14.80	6.71
3"	17.31	439	12.06	306	4.71	119	7.26	184	3.00	76	10.51	267	7.19	182	17.13	7.77
4"	18.60	472	12.06	306	5.52	140	8.88	225	4.00	101	13.08	332	8.76	222	28.45	12.90

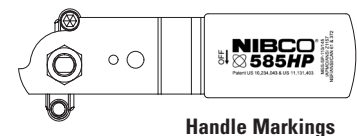

Handle Markings

\*NIBCO® Press System ball valves are designed to meet MSS SP-110 with the exception of the end connection. Ball valves are down-rated from T-585HP rated CWIP to the specified rating above to match the Press System.

GEOMET® is a registered trademark of NOF Metal Coatings, Inc.

QMONIX® is a trademark of Quadion LLC

**⚠ WARNING:** This product can expose you to chemicals including lead, which is known to the State of California to cause cancer and birth defects or other reproductive harm. For more information go to [www.P65Warnings.ca.gov](http://www.P65Warnings.ca.gov).

Visit our website for the most current information.

LEAD-FREE: Weighted average lead content ≤ 0.25%

## NIBCO® 585HP Lead-Free Bronze Ball Valves

**Features:** Silicon Performance Bronze® Alloy • Laser-Welded Cast Body • Triple-Sealed Stem • Stainless Trim • Reversible Handle • Easily Adjustable Packing Nut • Blowout-Proof Stem • Press Ends Leak Detection

**Approvals:** MSS-SP110/145 • IAPMO/ANSI Z1157 • NSF/ANSI/CAN 61-8 Commercial Hot 180° F • NSF/ANSI/CAN 372 • ICC-ES PMG-1558 • ASME A112.4.14/CSA B125.14

### Pressure/Temperature Rating:

**PC-585HP (1/2"-2"):** 250 psi non-shock cold working pressure\*

**PC-585HP (2 1/2"-4"):** 200 psi non-shock cold working pressure\*

**Maximum pressure/temperature: 225 psi at 250° F\* (1/2"-2")  
200 psi at 250° F\* (2 1/2"-4")**

Lead-free markings: Double oval in body casting, white handle and blue hang tag

United States Patent  
No. 10,234,043 &  
United States Patent  
No. 11,131,403



### MATERIAL LIST

PART	SPECIFICATION
1. Handle Nut	Carbon Steel, GEOMET® Coated
2. Handle Stop	ASTM A276 S31600 Stainless Steel
3. Stem	ASTM A276 S31600 Stainless Steel
4. Packing	PTFE
5. Packing Nut	ASTM B16 C36000 Brass
6. Stem O-ring (2)	Omonix® EPDM
7. Crimp Evident Seal (2)	EPDM - Leak Detection
8. Boss Seal O-ring (2)	EPDM
9. Body	ASTM B584 C87500 DZR Lead-free Silicon Bronze Casting
10. Seats (2)	Reinforced PTFE
11. Ball	ASTM A276 S31600 or A351 CF8M Stainless Steel
12. Body End Piece	ASTM B584 C87500 DZR Lead-free Silicon Bronze Casting
13. Press End Adapter (2)	ASTM B75 Alloy C12200 Wrot Copper
14. Handle	Carbon Steel, GEOMET® Coated, Plastisol Grip



**PC-585HP-66-LF**  
Press

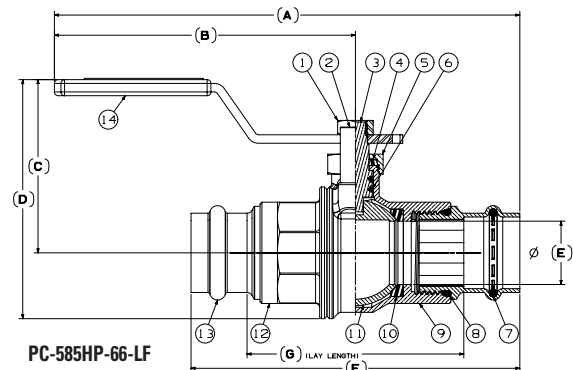

PC-585HP-66-LF

### Handle Options:

- NIB-SEAL® (1/4"-2")
- Locking Lever
- Stainless Steel
- Extended Lever w/  
Memory Stop

### DIMENSIONS - WEIGHTS

Size	A		B		C		D		E		F		G		Weights	
In.	In.	mm.	In.	mm.	In.	mm.	In.	mm.	In.	mm.	In.	mm.	In.	mm.	lbs.	kg
1/2"	5.93	151	4.04	103	2.03	52	2.66	68	0.50	13	3.77	96	2.37	60	0.80	0.36
3/4"	6.65	169	4.18	106	2.31	59	3.17	81	0.75	19	4.93	125	3.01	76	1.21	0.55
1"	7.35	187	4.75	121	2.74	70	3.78	96	1.00	25	5.19	132	3.42	87	1.58	0.72
1 1/4"	7.95	202	5.06	129	2.92	74	4.12	105	1.25	32	5.78	147	3.76	96	2.27	1.03
1 1/2"	10.25	260	6.75	171	3.22	82	4.64	118	1.50	38	7.01	178	4.24	108	3.55	1.61
2"	11.03	280	7.12	181	3.68	93	5.46	139	2.00	51	7.80	198	4.78	121	6.26	2.84
2.5"	16.86	428	12.06	306	4.41	112	6.62	168	2.50	63	9.61	244	6.67	169	14.80	6.71
3"	17.31	439	12.06	306	4.71	119	7.26	184	3.00	76	10.51	267	7.19	182	17.13	7.77
4"	18.60	472	12.06	306	5.52	140	8.88	225	4.00	101	13.08	332	8.76	222	28.45	12.90

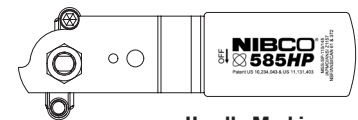

Handle Markings

\*NIBCO® Press System ball valves are designed to meet MSS SP-110 with the exception of the end connection. Ball valves are down-rated from T-585HP rated CWP to the specified rating above to match the Press System.

GEOMET® is a registered trademark of NOF Metal Coatings, Inc.

QMONIX® is a trademark of Quadion LLC

**WARNING:** This product can expose you to chemicals including lead, which is known to the State of California to cause cancer and birth defects or other reproductive harm. For more information go to [www.P65Warnings.ca.gov](http://www.P65Warnings.ca.gov).

LEAD-FREE: Weighted average lead content ≤ 0.25%

Visit our website for the most current information.

# NIBCO® 585HP Lead-Free Bronze Ball Valves

**Features:** Silicon Performance Bronze® Alloy • Laser-Welded Cast Body • Triple-Sealed Stem • Reversible Handle • Easily Adjustable Packing Nut • Blowout-Proof Stem • Press Ends Leak Detection

**Approvals:** MSS-SP110/145 • IAPMO/ANSI Z1157 • NSF/ANSI/CAN 61-8 Commercial Hot 180° F • NSF/ANSI/CAN 372 • ICC-ES PMG-1558 • ASME A112.4.14/CSA B125.14

**Size range:** ½" - 2"

**Pressure rating:** 250 psi non-shock cold working pressure\*

**Body design pressure:** 1,000 psi non-shock cold working pressure

**Maximum pressure / temperature:** 225 psi at 250° F\*

Lead-free markings: Double oval in body casting, white handle and blue hang tag

United States Patent No. 10,234,043 & United States Patent No. 11,131,403



## MATERIAL LIST

PART	SPECIFICATION
1. Handle Nut	Carbon Steel, GEOMET® Coated
2. Handle Stop	ASTM A276 S31600 Stainless Steel
3. Stem	ASTM C69300 Lead-free Silicon Bronze ASTM A276 316 Stainless Steel
4. Packing	PTFE
5. Packing Nut	ASTM B16 C36000 Brass
6. Stem O-ring (2)	Omonix® EPDM
7. Crimp Evident Seal	EPDM - Leak Detection
8. Boss Seal O-ring	EPDM
9. Body	ASTM B584 C87500 DZR Lead-free Silicon Bronze Casting
10. Seats (2)	Reinforced PTFE
11. Ball	ASTM B584 C46500 DZR Lead-free Brass (½" - 1") ASTM A276 or A351 CF8M Stainless Steel (1¼" - 2")
12. Body End Piece	ASTM B584 C87500 DZR Lead-free Silicon Bronze Casting
13. Press End Adapter	ASTM B75 Alloy C12200 Wrot Copper
14. Handle	Carbon Steel, GEOMET® Coated, Plastisol Grip

### Handle Options:

- NIB-SEAL®
- Locking Lever
- Extended Lever w/ Memory Stop

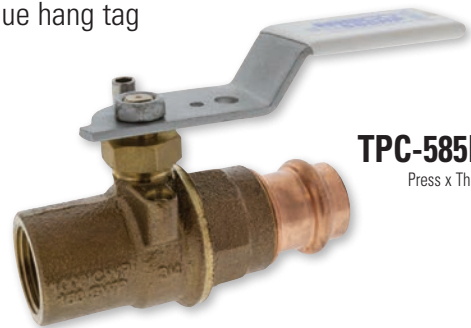

**TPC-585HP-LF**  
Press x Thread

TPC-585HP-66-LF with stainless steel trim also available.

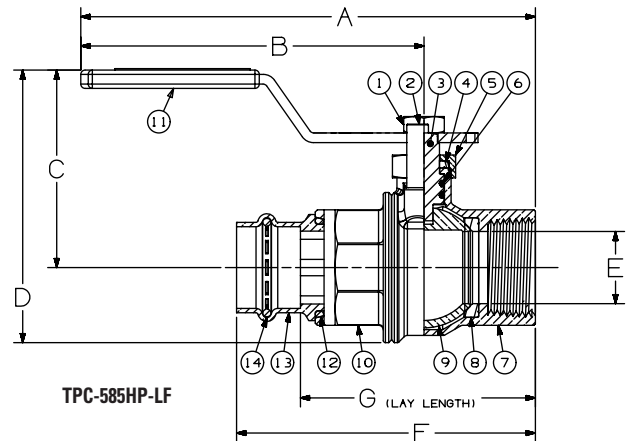

TPC-585HP-LF

## DIMENSIONS - WEIGHTS

Size	A		B		C		D		E		F		G		Weights	
In.	In.	mm.	In.	mm.	In.	mm.	In.	mm.	In.	mm.	In.	mm.	In.	mm.	lbs.	kg
½"	5.11	129.8	4.04	102.6	2.03	51.6	2.65	67.3	0.50	12.7	3.08	78.2	2.39	60.7	0.740	0.336
¾"	5.52	140.2	4.18	106.2	2.31	58.7	3.20	81.3	0.75	19.1	3.93	99.8	2.97	75.4	1.293	0.586
1"	6.30	160.0	4.75	120.7	2.74	69.6	3.80	96.5	1.00	25.4	4.27	108.5	3.38	85.9	1.761	0.799
1¼"	6.75	171.5	5.06	128.5	2.92	74.2	4.15	105.4	1.25	31.8	4.71	119.6	3.70	94.0	2.714	1.231
1½"	8.65	219.7	6.75	171.5	3.22	81.8	4.65	118.1	1.50	38.1	5.53	140.5	4.15	105.4	3.903	1.770
2"	9.29	236.0	7.12	180.8	3.68	93.5	5.45	138.4	2.00	50.8	6.20	157.5	4.69	119.1	5.893	2.673

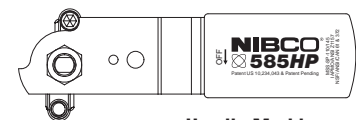

Handle Markings

\*NIBCO® Press System ball valves are designed to meet MSS SP-110 with the exception of the end connection. Ball valves are down-rated from 1000 psi CWP to 250 psi CWP to match the Press System.

GEOMET® is a registered trademark of NOF Metal Coatings, Inc.

OMONIX® is a trademark of Quadion LLC

**WARNING:** This product can expose you to chemicals including lead, which is known to the State of California to cause cancer and birth defects or other reproductive harm. For more information go to [www.P65Warnings.ca.gov](http://www.P65Warnings.ca.gov).

Visit our website for the most current information.

LEAD-FREE: Weighted average lead content ≤ 0.25%

# NIBCO® 585HP Lead-Free Bronze Ball Valves

**Features:** Silicon Performance Bronze® Alloy • Laser-Welded Cast Body • Triple-Sealed Stem • Reversible Handle • Easily Adjustable Packing Nut • Blowout-Proof Stem • Hose Cap and Chain • Press Ends Leak Detection

**Approvals:** MSS SP-110/145 • NSF/ANSI/CAN 61-8 & 372 • IAPMO/ANSI Z1157

**Size range:** 1/2", 3/4"

**Pressure rating:** 250 psi non-shock cold working pressure\*

**Body design pressure:** 1,000 psi non-shock cold working pressure

Lead-free markings: Double oval in body casting, white handle and blue hang tag

United States Patent No. 10,234,043 & United States Patent No. 11,131,403



## MATERIAL LIST

PART	SPECIFICATION
1. Handle Nut	Carbon Steel, GEOMET® Coated
2. Handle Stop	ASTM A276 S31600 Stainless Steel
3. Stem	ASTM C69300 DZR Lead-free Silicon Brass ASTM A276 316 Stainless Steel
4. Packing	PTFE
5. Packing Nut	ASTM B16 C36000 Brass
6. Stem O-ring (2)	Omonix® EPDM
7. Press End Adapter	C12200 Wrought Copper
8. Crimp Evident Seal	EPDM - Leak Detection
9. Boss Seal O-ring	EPDM
10. Seats (2)	Reinforced PTFE
11. Ball	ASTM B584 46500 DZR Lead-free Brass ASTM A276 or A351 CF8M Stainless Steel
12. Body	ASTM B584 C87500 DZR Lead-free Silicon Bronze Casting
13. Body End Piece	ASTM B371 C69300 DZR Lead-free Silicon Brass
14. Hose Cap Assembly <sup>1</sup>	Die Cast Brass, EPDM Gasket, Soft PVC Retainer
15. Handle	Carbon Steel, GEOMET® Coated, Plastisol Grip

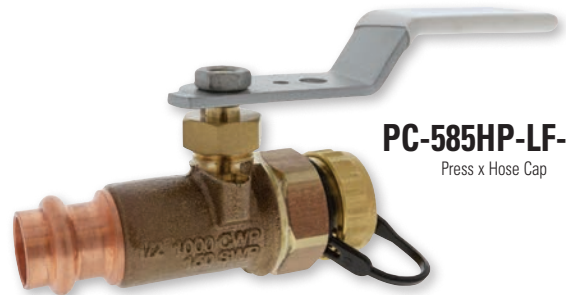

**PC-585HP-LF-HC**  
Press x Hose Cap

PC-585HP-66-LF-HC with stainless steel trim also available.

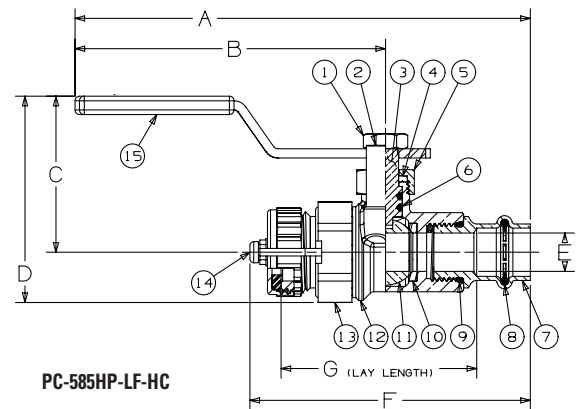

PC-585HP-LF-HC

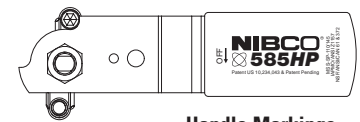

Handle Markings

## DIMENSIONS - WEIGHTS

Size	A		B		C		D		E		F		G		Weights	
	In.	mm.	In.	mm.	In.	mm.	In.	mm.	In.	mm.	In.	mm.	In.	mm.	lbs.	kg
1/2"	5.93	150.62	4.04	102.62	2.03	51.56	2.69	68.33	0.50	12.70	3.65	92.71	2.55	64.77	0.780	0.354
3/4"	6.65	168.91	4.18	106.17	2.31	58.67	3.18	80.77	0.75	19.05	4.26	108.20	2.89	73.41	1.112	0.504

Note: 1. Cap is for hose end thread protection only. Not to be used for pressure containing purposes.

\*NIBCO® Press System ball valves are designed to meet MSS SP-110, with the exception of the end connection. Ball valves are downrated from 1000 psi CWP to 250 psi CWP to match the Press System.

GEOMET® is a registered trademark of NOF Metal Coatings, Inc.

QMONIX® is a trademark of Quadion LLC

**WARNING:** This product can expose you to chemicals including lead, which is known to the State of California to cause cancer and birth defects or other reproductive harm. For more information go to [www.P65Warnings.ca.gov](http://www.P65Warnings.ca.gov).

LEAD-FREE: Weighted average lead content ≤ 0.25%

Visit our website for the most current information.

# NIBCO® Press System Bronze Ball Valves

Two-Piece Body • Full Port • Bronze Trim • Blowout-Proof Stem • Press Ends Leak Detection



**250 psi/17.2 bar non-shock cold working pressure**  
**Maximum Pressure/Temperature: 200 psi at 250°F**

CONFORMS TO MSS SP-110

## MATERIAL LIST

PART	SPECIFICATION
1. Body	Bronze ASTM B584 Alloy C84400
2. Body End	Bronze ASTM B584 Alloy C84400
3. Press End Adapter (2)	Wrot Copper ASTM B75 Alloy C12200
4. Ball	Brass ASTM B16 Alloy C36000 or ASTM B283 Alloy C37700 (Chrome/Nickel Plated)
5. Seat Ring (2)	Reinforced PTFE
6. Boss seal o-ring (2)	EPDM
7. Crimp Evident Seal (2)	EPDM - Leak Detection
8. Packing	PTFE
9. Pack Gland	Brass ASTM B16 Alloy C36000
10. Stem	Silicon Bronze ASTM B371 Alloy C69430 or ASTM B371 ALLOY C69300
11. Handle Nut	Zinc Plated Steel
12. Thrust Washer	Reinforced PTFE
13. Handle Assembly	Zinc Plated Steel Clear Chromate Plastisol Coated



### PC-585-70

Press x Press  
Female End

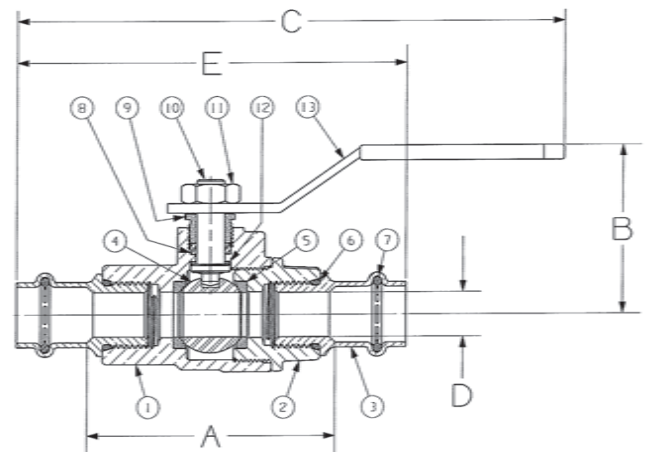

PC-585-70  
P x P

### Handle Options:

- Stainless steel lever
- NIB-SEAL®
- Locking lever
- Stainless steel locking lever
- Memory stop
- Extended lever w/ memory stop
- Round
- Wing
- Horizontal and vertical chain

## DIMENSIONS—WEIGHTS

SIZE	Dimensions										Weight		
	A		B		C		D		E		Lbs.	Kg.	
In. mm.	In. mm.	In. mm.	In. mm.	In. mm.	In. mm.	In. mm.	In. mm.	In. mm.	In. mm.	Lbs.	Kg.		
1/2"	13	2.76	70	1.90	48	6.00	152	.50	13	4.15	105	.80	.36
3/4"	19	3.28	83	2.28	58	7.29	185	.75	19	5.05	128	1.56	.71
1"	25	3.59	91	2.41	61	7.34	186	1.00	25	5.36	136	2.13	1.00
1¼"	32	4.62	117	3.05	77	10.04	255	1.25	32	6.64	169	3.73	1.69
1½"	38	5.23	133	3.30	84	10.72	272	1.50	38	8.00	203	5.53	2.51
2"	50	5.63	143	3.51	89	11.05	281	2.00	50	8.65	220	7.95	3.61

NIBCO Press end ball valves are designed to MSS SP-110 with the exception of Press connections are designed to MSS SP-145. Valves with Press ends are rated to align with NIBCO Press System max pressure.

**WARNING:** This product can expose you to chemicals including lead, which is known to the State of California to cause cancer and birth defects or other reproductive harm. For more information go to [www.P65Warnings.ca.gov](http://www.P65Warnings.ca.gov).

Visit our website for the most current information.

# NIBCO® Press System Bronze Ball Valves

Two-Piece Body • Full Port • Stainless Trim • Blowout-Proof Stem • Vented Ball • Press Ends Leak Detection

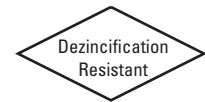

**250 psi/17.2 bar non-shock cold working pressure**  
**Maximum Pressure/Temperature: 200 psi at 250°F**

CONFORMS TO MSS SP-110

## MATERIAL LIST

PART	SPECIFICATION
1. Body	Bronze ASTM B584 Alloy C84400
2. Body End	Bronze ASTM B584 Alloy C84400
3. Press End Adapter (2)	Wrot Copper ASTM B75 Alloy C12200
4. Ball (vented)	Stainless Steel ASTM A276 Type 316 or ASTM A351 Type CF8M
5. Seat Ring (2)	Reinforced PTFE
6. Boss Seal O-Ring (2)	EPDM
7. Crimp Evident Seal (2)	EPDM - Leak Detection
8. Packing	PTFE
9. Pack Gland	Brass ASTM B16 Alloy C36000
10. Stem	Stainless Steel ASTM A276 Alloy S31600
11. Handle Nut	300 Series Stainless Steel
12. Thrust Washer	Reinforced PTFE
13. Handle Assembly	Zinc Plated Steel Clear Chromate Plastisol Coated



**PC-585-70-66**

Press x Press  
Female End

### Handle Options:

- Stainless steel lever
- NIB-SEAL®
- Locking lever
- Stainless steel locking lever
- Memory stop
- Extended lever w/ memory stop
- Round
- Wing
- Horizontal and vertical chain

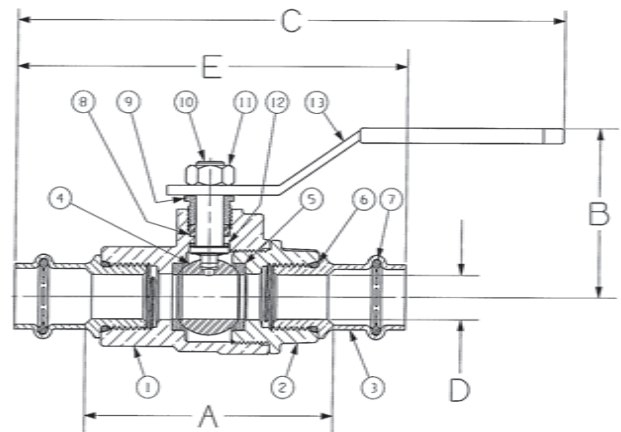

**PC-585-70-66**  
P x P

## DIMENSIONS—WEIGHTS

SIZE	Dimensions					Weight							
	A	B	C	D	E	Lbs.	Kg.						
1/2"	13	2.76	70	1.90	48	6.00	152	.50	13	4.15	105	.77	.35
3/4"	19	3.28	83	2.28	58	7.29	185	.75	19	5.05	128	1.55	.70
1"	25	3.59	91	2.40	61	7.34	186	1.00	25	5.36	136	2.29	1.04
1 1/4"	32	4.62	117	3.05	77	10.04	255	1.25	32	6.64	169	3.80	1.72
1 1/2"	38	5.23	133	3.30	84	10.72	272	1.50	38	8.00	203	5.60	2.54
2"	50	5.63	143	3.51	89	11.05	281	2.00	50	8.65	220	8.69	3.94

NIBCO Press end ball valves are designed to MSS SP-110 with the exception of Press connections are designed to MSS SP-145. Valves with Press ends are rated to align with NIBCO Press System max pressure.

**WARNING:** This product can expose you to chemicals including lead, which is known to the State of California to cause cancer and birth defects or other reproductive harm. For more information go to [www.P65Warnings.ca.gov](http://www.P65Warnings.ca.gov).

Visit our website for the most current information.

# NIBCO® Press System Bronze Ball Valves

Two-Piece Body • Full Port • Bronze Trim • Blowout-Proof Stem • Press Ends Leak Detection

**250 psi/17.2 bar non-shock cold working pressure**  
**Maximum Pressure/Temperature: 200 psi at 250°F**

CONFORMS TO MSS SP-110

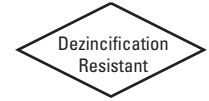

## MATERIAL LIST

PART	SPECIFICATION
1. Handle Nut	Zinc Plated Steel
2. Stem	Silicon Bronze ASTM B371 Alloy C69300 or ASTM B371 Alloy C69430
3. Pack Gland	Brass ASTM B16 Alloy C36000
4. Packing, Stem	PTFE
5. Thrust Washer	Reinforced PTFE
6. Handle Assembly	Zinc Plated Steel with Plastisol Coating
7. Body End	Bronze ASTM B584 Alloy C84400
8. Seat Ring (2)	Reinforced PTFE
9. Ball	Brass ASTM B16 Alloy C36000 or ASTM B283 Alloy C37700 (Chrome/Nickel Plated)
10. Body	Bronze ASTM B584 Alloy C84400
11. Boss seal o-ring	EPDM
12. Crimp Evident Seal	EPDM - Leak Detection
13. Press End Adapter	Wrot Copper ASTM B75 Alloy C12200

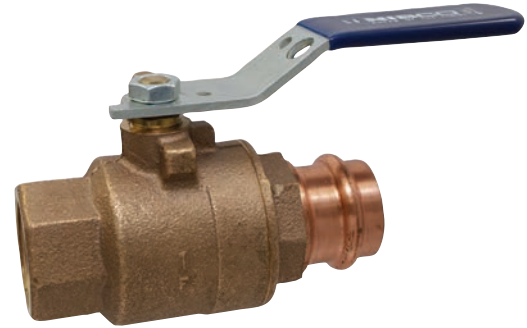

**TPC-585-70**

Thread x Press  
Female

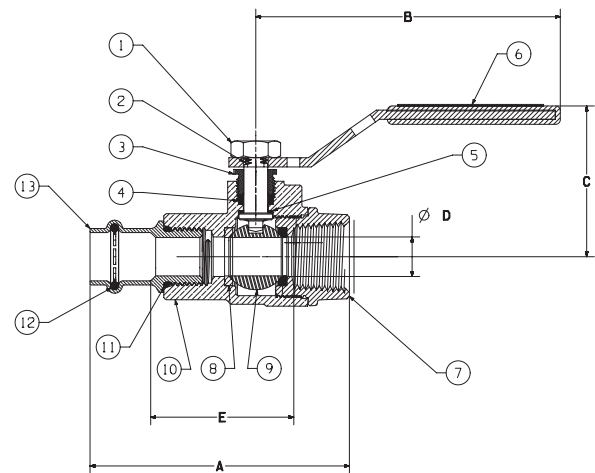

**TPC-585-70**  
NPT x P

### Handle Options:

- Stainless steel lever
- NIB-SEAL®
- Locking lever
- Stainless steel locking lever
- Memory stop
- Extended lever w/ memory stop
- Round
- Wing
- Horizontal and vertical chain

## DIMENSIONS—WEIGHTS—QUANTITIES

SIZE	Dimensions					Weight		Master Ctn. Qty.						
	A	B	C	D	E	Lbs.	Kg.							
1/2"	15	3.38	86	3.96	101	1.96	50	0.50	13	1.86	47	0.85	0.39	50
3/4"	20	4.08	104	4.76	121	2.28	58	0.75	19	2.42	61	1.50	0.68	30
1"	25	4.44	113	4.76	121	2.48	63	1.00	25	2.71	69	2.00	0.91	20
1¼"	32	5.46	139	6.75	171	3.09	78	1.25	32	3.67	93	3.55	1.61	12
1½"	40	6.27	159	6.75	171	3.32	84	1.50	38	4.15	105	4.90	2.22	6
2"	50	6.99	176	6.75	171	3.56	90	2.00	51	4.64	118	6.90	3.13	6

NIBCO Press end ball valves are designed to MSS SP-110 with the exception of Press connections are designed to MSS SP-145. Valves with Press ends are rated to align with NIBCO Press System max pressure.

**WARNING:** This product can expose you to chemicals including lead, which is known to the State of California to cause cancer and birth defects or other reproductive harm. For more information go to [www.P65Warnings.ca.gov](http://www.P65Warnings.ca.gov).

Visit our website for the most current information.

# NIBCO® Press System Bronze Ball Valves

Two-Piece Body • Full Port • Stainless Trim • Blowout-Proof Stem • Vented Ball • Press Ends Leak Detection

**250 psi/17.2 bar non-shock cold working pressure**  
**Maximum Pressure/Temperature: 200 psi at 250°F**

CONFORMS TO MSS SP-110

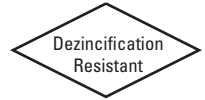

## MATERIAL LIST

PART	SPECIFICATION
1. Handle Nut	300 Series Stainless Steel
2. Stem	Stainless Steel ASTM A276 Type 316
3. Pack Gland	Brass ASTM B16 Alloy C36000
4. Packing, Stem	PTFE
5. Thrust Washer	Reinforced PTFE
6. Handle Assembly	Zinc Plated Steel Clear Chromate Plastisol Coated
7. Body End	Bronze ASTM B584 Alloy C84400
8. Seat Ring (2)	Reinforced PTFE
9. Ball	Stainless Steel ASTM A276 Alloy S31600 or ASTM A351 Type CF8M
10. Body	Bronze ASTM B584 Alloy C84400
11. Boss seal o-ring	EPDM
12. Crimp Evident Seal	EPDM - Leak Detection
13. Press End Adapter	Wrot Copper ASTM B75 Alloy C12200



**TPC-585-70-66**

Thread x Press  
Female

### Handle Options:

- Stainless steel lever
- NIB-SEAL®
- Locking lever
- Stainless steel locking lever
- Memory stop
- Extended lever w/ memory stop
- Round
- Wing
- Horizontal and vertical chain

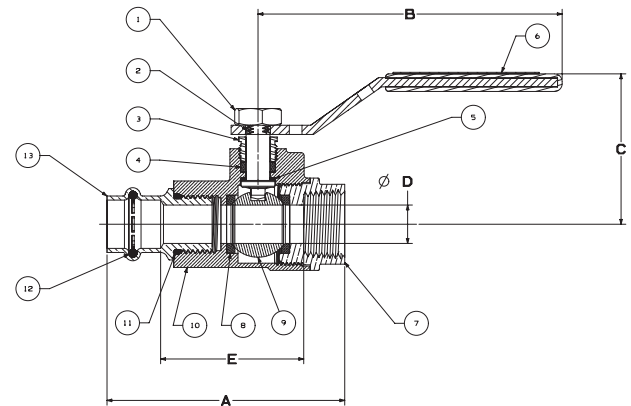

**TPC-585-70-66**  
NPT x P

## DIMENSIONS—WEIGHTS—QUANTITIES

SIZE	Dimensions										Weight		Master Ctn. Qty.	
	A	B	C	D	E									
In. mm.	In. mm.	In. mm.	In. mm.	In. mm.	In. mm.	In. mm.	Lbs.	Kg.						
1/2"	15	3.10	79	3.96	101	1.96	50	0.50	13	1.86	47	0.85	0.39	50
3/4"	20	3.96	101	4.76	121	2.28	58	0.75	19	2.45	62	1.50	0.68	30
1"	25	4.47	114	4.76	121	2.48	63	1.00	25	2.92	74	2.00	0.91	20
1 1/4"	32	4.99	127	6.75	171	3.09	78	1.25	32	3.30	84	3.55	1.61	12
1 1/2"	40	5.90	150	6.75	171	3.32	84	1.50	38	3.84	98	4.90	2.22	6
2"	50	6.61	168	6.75	171	3.56	90	2.00	51	4.38	111	6.90	3.13	6

NIBCO Press end ball valves are designed to MSS SP-110 with the exception of Press connections are designed to MSS SP-145. Valves with Press ends are rated to align with NIBCO Press System max pressure.

**WARNING:** This product can expose you to chemicals including lead, which is known to the State of California to cause cancer and birth defects or other reproductive harm. For more information go to [www.P65Warnings.ca.gov](http://www.P65Warnings.ca.gov).

Visit our website for the most current information.

# NIBCO® Press System Bronze Ball Valves

Two-Piece Body • Full Port • Bronze Trim • Blowout-Proof Stem •  
3/4" Hose Connection w/Cap and Chain • Press Ends Leak Detection

**250 psi/17.2 bar non-shock cold working pressure**

CONFORMS TO MSS SP-110

## MATERIAL LIST

PART	SPECIFICATION
1. Press End Adapter	Wrot Copper ASTM B75 Alloy C12200
2. Body	Bronze ASTM B584 Alloy C84400
3. Hose Body End	Brass ASTM B124 Alloy C37700
4. Hose Cap Assembly <sup>1</sup>	Die Cast Brass , EPDM Gasket, Soft PVC Retainer
5. Crimp Evident Seal	EPDM - Leak Detection
6. Boss seal o-ring	EPDM
7. Ball	Brass ASTM B16 Alloy C36000 or ASTM B283 Alloy C37700 (Chrome/Nickel Plated)
8. Packing	PTFE
9. Pack Gland	Brass ASTM B16 Alloy C36000
10. Stem	Silicon Bronze ASTM B371 Alloy C69300 or ASTM B371 Alloy C69430
11. Handle Nut	Zinc Plated Steel
12. Thrust Washer	Reinforced PTFE
13. Handle Assembly	Zinc Plated Steel Clear Chromate Plastisol Coated
14. Seat Ring (2)	Reinforced PTFE



**PC-585-70-HC**  
Press Female x Hose End

<sup>1</sup> Cap is for hose end thread protection only. Not to be used for pressure containing purposes.

### Handle Options:

- Stainless steel lever
- NIB-Seal®
- Locking lever
- Stainless steel locking lever
- Memory stop
- Extended lever w/ memory stop
- Round
- Wing
- Horizontal and vertical chain

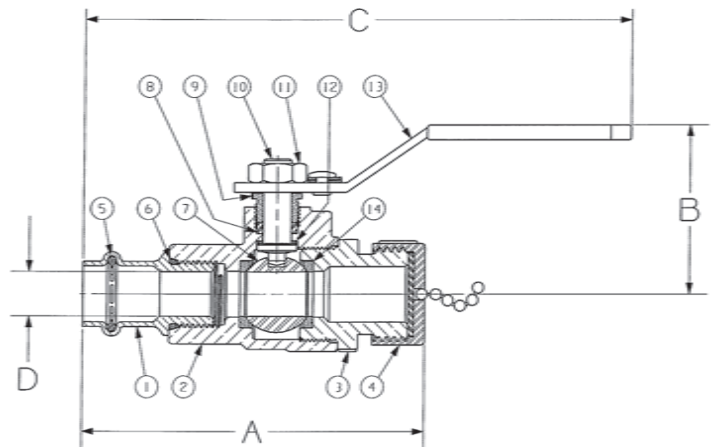

**PC-585-70-HC**  
P x Hose

## DIMENSIONS—WEIGHTS

SIZE	Dimensions								Weight	
	A		B		C		D		Lbs.	Kg.
In. mm.	In. mm.	In. mm.	In. mm.	In. mm.	In. mm.	In. mm.	In. mm.	Lbs.	Kg.	
1/2" 13	3.06 78	1.88 48	6.09 155	.50 13	.92	.42				
3/4" 19	4.47 114	2.25 57	7.36 187	.75 19	1.70	.77				

NIBCO Press end ball valves are designed to MSS SP-110 with the exception of Press connections are designed to MSS SP-145. Valves with Press ends are rated to align with NIBCO Press System max pressure.

**WARNING:** This product can expose you to chemicals including lead, which is known to the State of California to cause cancer and birth defects or other reproductive harm. For more information go to [www.P65Warnings.ca.gov](http://www.P65Warnings.ca.gov).

Visit our website for the most current information.

# NIBCO® Press System Bronze Ball Valves

Two-Piece Body • Full Port • Stainless Trim • Blowout-Proof Stem • Vented Ball •  
3/4" Hose Connection with Cap and Chain • Press Ends Leak Detection

**250 psi/17.2 bar non-shock cold working pressure**

CONFORMS TO MSS SP-110

## MATERIAL LIST

PART	SPECIFICATION
1. Press End Adapter	Wrot Copper ASTM B75 Alloy C12200
2. Body	Bronze ASTM B584 Alloy C84400
3. Hose Body End	Brass ASTM B124 Alloy C37700
4. Hose Cap Assembly <sup>1</sup>	Die Cast Brass, EPDM Gasket, Soft PVC Retainer
5. Crimp Evident Seal	EPDM - Leak Detection
6. Boss seal o-ring	EPDM
7. Ball (vented)	Stainless Steel ASTM A276 Alloy S31600 or ASTM A351 Type CF8M
8. Packing	PTFE
9. Pack Gland	Brass ASTM B16 Alloy C36000
10. Stem	Stainless Steel ASTM A276 Alloy S31600
11. Handle Nut	300 Series Stainless Steel
12. Thrust Washer	Reinforced PTFE
13. Handle Assembly	Zinc Plated Steel Clear Chromate Plastisol Coated
14. Seat Ring (2)	Reinforced PTFE

<sup>1</sup> Cap is for hose end thread protection only. Not to be used for pressure containing purposes.

### Handle Options:

- Stainless steel lever
- NIB-SEAL®
- Locking lever
- Stainless steel locking lever
- Memory stop
- Extended lever w/ memory stop
- Round
- Wing
- Horizontal and vertical chain



**PC-585-70-66-HC**  
Press Female x Hose End

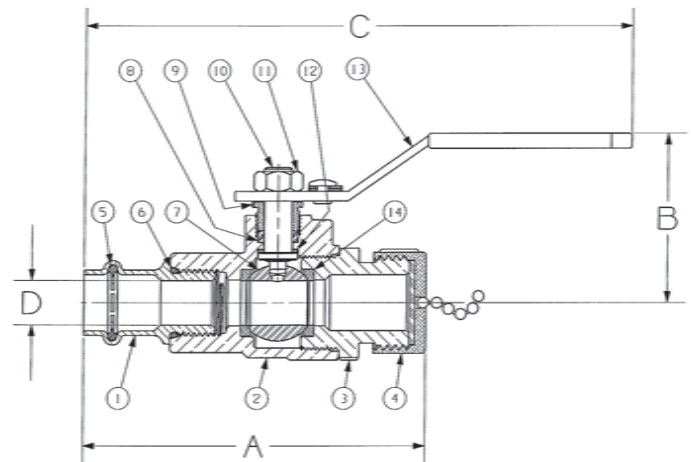

**PC-585-70-66-HC**  
P x Hose

## DIMENSIONS—WEIGHTS

SIZE	Dimensions								Weight	
	A		B		C		D		Lbs.	Kg.
In. mm.	In. mm.	In. mm.	In. mm.	In. mm.	In. mm.	In. mm.	In. mm.			
1/2" 13	2.76 70	1.88 48	6.09 155	.50 13	.92	.42				
3/4" 19	3.28 83	2.25 57	7.36 187	.75 19	1.70	.77				

NIBCO Press end ball valves are designed to MSS SP-110 with the exception of Press connections are designed to MSS SP-145. Valves with Press ends are rated to align with NIBCO Press System max pressure.

**WARNING:** This product can expose you to chemicals including lead, which is known to the State of California to cause cancer and birth defects or other reproductive harm. For more information go to [www.P65Warnings.ca.gov](http://www.P65Warnings.ca.gov).

Visit our website for the most current information.

# NIBCO® Press System Lead-Free Bronze Ball Valves

**Features:** Silicon Performance Bronze® Two-Piece Body • Press Ends Leak Detection • Full Port • Blowout-Proof Stem

United States Patent No. 10,234,043 & United States Patent No. 11,131,403

**Approvals:** MSS SP-110/145 • IAPMO/ANSI Z1157 • NSF/ANSI/CAN 61-8 & 372 Commercial Hot 1

**Size range:** ½" - 3"

**Pressure rating:** 250\* PSI non-shock cold working pressure

**Body design pressure:** 600 PSI CWP non-shock cold working pressure

**Maximum pressure / temperature:** 225 PSI at 250° F\*

Lead-free markings: Double oval in body casting, white handle and blue hang tag



## MATERIAL LIST

PART	SPECIFICATION
1. Handle Nut	Zinc Plated Steel
2. Stem	Silicon Bronze ASTM B371 Alloy C69300
3. Pack Gland	Brass ASTM B16 Alloy C36000
4. Packing, Stem	PTFE
5. Thrust Washer	Reinforced PTFE
6. Handle Assembly	Zinc Plated Steel Clear Chromate Plastisol Coated
7. Body End	Silicon Bronze ASTM B584 Alloy C87600
8. Seat Ring (2)	Reinforced PTFE
9. Ball (vented)	DZR Brass SAE J461 C46500 (¼"-1") Stainless Steel ASTM A276 S31600 or ASTM A351 CF8M (1¼"-3")
10. Body	Silicon Bronze ASTM B584 Alloy C87600
11. Boss seal o-ring (2)	EPDM
12. Crimp Evident Seal (2)	EPDM - Leak Detection
13. Press End Adapter (2)	Wrot Copper ASTM B75 Alloy C12200



**PC-585-80-LF**

Press x Press  
Female End

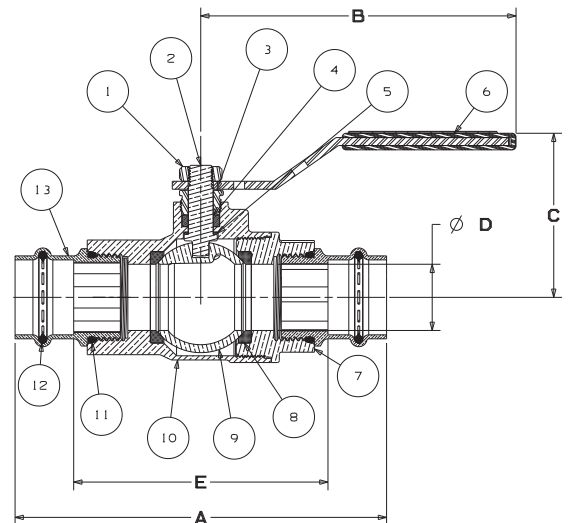

**PC-585-80-LF**  
P x P

### Handle Options:

- Stainless Steel Lever
- NIB-SEAL®
- Locking Lever
- Stainless Steel Locking Lever
- Memory Stop
- Extended Lever w/ Memory Stop
- Round
- Wing
- Horizontal and Vertical Chain

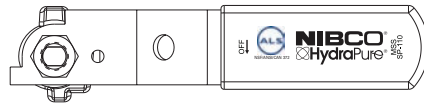

Handle Markings

## DIMENSIONS—WEIGHTS—QUANTITIES

SIZE		A		B		C		D		E		Weight	
In.	mm.	In.	mm.	In.	mm.	In.	mm.	In.	mm.	In.	mm.	Lbs.	Kg.
1/2	15	3.93	100	3.96	101	1.96	50	0.50	13	2.53	64	0.80	0.36
3/4	20	5.00	127	4.76	121	2.28	58	0.75	19	3.23	82	1.56	0.71
1	25	5.61	142	4.76	121	2.48	63	1.00	25	3.84	98	2.13	1.00
1¼	32	6.23	158	6.76	172	3.10	79	1.25	32	4.21	107	3.73	1.69
1½	40	7.56	192	6.76	172	3.32	84	1.50	38	4.79	122	5.53	2.51
2	50	8.40	213	6.76	172	3.56	90	2.00	51	5.36	136	7.95	3.61
2½	65	9.49	241	8.06	205	4.33	110	2.50	64	6.55	166	16.20	7.35
3	76	10.45	265	8.06	205	4.58	116	2.95	75	7.13	181	16.50	7.48

\*200 PSI CWP and 200 PSI at 200°F for 2½" and above

NIBCO Press end ball valves are designed to MSS SP-110 with the exception of Press connections are designed to MSS SP-145. Valves with Press ends are rated to align with NIBCO Press System max pressure.



**WARNING:** This product can expose you to chemicals including lead, which is known to the State of California to cause cancer and birth defects or other reproductive harm. For more information go to [www.P65Warnings.ca.gov](http://www.P65Warnings.ca.gov).

Visit our website for the most current information.

LEAD-FREE: Weighted average lead content ≤ 0.25%

# NIBCO® Press System Lead-Free Bronze Ball Valves

United States Patent No. 10,234,043 & United States Patent No. 11,131,403

**Features:** Silicon Performance Bronze® Two-Piece Body • Copper Ends • Full Port • Blowout-Proof Stem • Stainless Trim

**Approvals:** MSS SP-110/145 • IAPMO/ANSI Z1157 • NSF/ANSI/CAN 61-8 & 372 Commercial Hot 180°F

**Size range:** ½" - 3"

**Pressure rating:** 250\* PSI non-shock cold working pressure

**Body design pressure:** 600 PSI CWP non-shock cold working pressure

**Maximum pressure / temperature:** 225 PSI at 250° F\*

Lead-free markings: Double oval in body casting, white handle and blue hang tag

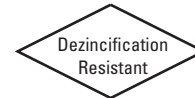

## MATERIAL LIST

PART	SPECIFICATION
1. Handle Nut	Zinc Plated Steel
2. Stem	Stainless Steel ASTM A276 Type 316
3. Pack Gland	Brass ASTM B16 Alloy C36000
4. Packing, Stem	PTFE
5. Thrust Washer	Reinforced PTFE
6. Handle Assembly	Plated Steel with Plastisol Coating
7. Body End	Silicon Bronze ASTM B584 Alloy C87600
8. Seat Ring (2)	Reinforced PTFE
9. Ball (vented)	Stainless Steel ASTM A276 Type 316
10. Body	Silicon Bronze ASTM B584 Alloy C87600
11. Boss seal o-ring (2)	EPDM
12. Crimp Evident Seal (2)	EPDM - Leak Detection
13. Press End Adapter (2)	Wrot Copper ASTM B75 Alloy C12200



### PC-585-66-LF

Press x Press  
Female End

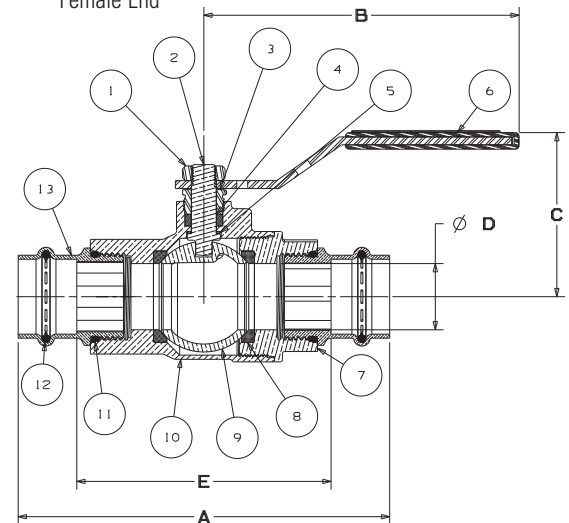

PC-585-66-LF  
P x P

#### Handle Options:

- Stainless Steel Lever
- NIB-SEAL®
- Locking Lever
- Stainless Steel Locking Lever
- Memory Stop
- Extended Lever w/ Memory Stop
- Round
- Wing
- Horizontal and Vertical Chain



Handle Markings

## DIMENSIONS—WEIGHTS—QUANTITIES

SIZE		A		B		C		D		E		Weight	
In.	mm.	In.	mm.	In.	mm.	In.	mm.	In.	mm.	In.	mm.	Lbs.	Kg.
1/2	15	3.93	100	3.96	101	1.96	50	0.50	13	2.53	64	0.80	0.36
3/4	20	5.00	127	4.76	121	2.28	58	0.75	19	3.23	82	1.56	0.71
1	25	5.61	142	4.76	121	2.48	63	1.00	25	3.84	98	2.13	1.00
1-1/4	32	6.23	158	6.76	172	3.10	79	1.25	32	4.21	107	3.73	1.69
1-1/2	40	7.56	192	6.76	172	3.32	84	1.50	38	4.79	122	5.53	2.51
2	50	8.40	213	6.76	172	3.56	90	2.00	51	5.36	136	7.95	3.61
2-1/2	65	9.49	241	8.06	205	4.33	110	2.50	64	6.55	166	16.20	7.35
3	76	10.45	265	8.06	205	4.58	116	2.95	75	7.13	181	16.50	7.48

\*200 PSI CWP and 200 PSI at 200°F for 2½" and above

NIBCO Press end ball valves are designed to MSS SP-110 with the exception of Press connections are designed to MSS SP-145. Valves with Press ends are rated to align with NIBCO Press System max pressure.



**WARNING:** This product can expose you to chemicals including lead, which is known to the State of California to cause cancer and birth defects or other reproductive harm. For more information go to [www.P65Warnings.ca.gov](http://www.P65Warnings.ca.gov).

LEAD-FREE: Weighted average lead content ≤ 0.25%

Visit our website for the most current information.

# NIBCO® Press System Lead-Free Bronze Ball Valves

**Features:** Silicon Performance Bronze® Alloy • Two-Piece Body • Full Port • Blowout-Proof Stem • Copper End x 3/4" Hose Connection with Cap and Chain

**Approvals:** MSS SP-110/145 • IAPMO/ANSI Z1157 • NSF/ANSI/CAN 61-8 & 372

**Size range:** 1/2" & 3/4"

**Pressure rating:** 250 PSI non-shock cold working pressure

Lead-free markings: Double oval in body casting, white handle and blue hang tag



## MATERIAL LIST

PART	SPECIFICATION
1. Handle Nut	Zinc Plated Steel
2. Stem	Silicon Bronze ASTM B371 Alloy C69300
3. Pack Gland	Brass ASTM B16 Alloy C36000
4. Packing	PTFE
5. Thrust Washer	Reinforced PTFE
6. Handle Assembly	Zinc Plated Steel with Plastisol Coating
7. Hose Body End	Silicon Bronze ASTM B371 Alloy C69300
8. Ball	Silicon Bronze ASTM B283 Alloy C69300
9. Seat Ring (2)	Reinforced PTFE
10. Body	Silicon Bronze ASTM B584 Alloy C87600
11. Boss seal o-ring	EPDM
12. Crimp Evident Seal	EPDM - Leak Detection
13. Press End Adapter	Wrot Copper ASTM B75 Alloy C12200
14. Hose Cap Assembly <sup>1</sup>	Die Cast Brass, EPDM Gasket, Soft PVC Retainer

<sup>1</sup> Cap is for hose end thread protection only. Not to be used for pressure containing purposes.



**PC-585-80-LF-HC**  
Press Female x Hose End

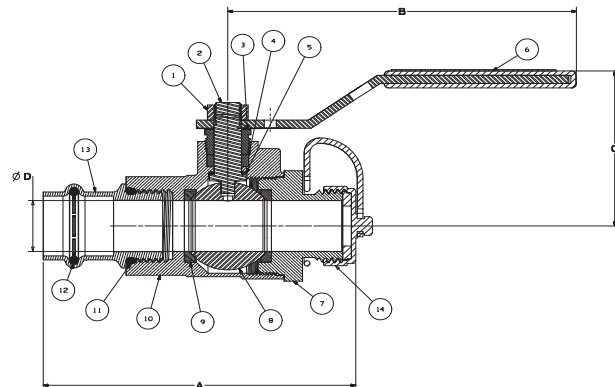

**PC-585-80-LF-HC**  
P x Hose

### Handle Options:

- Stainless Steel Lever
- NIB-SEAL®
- Locking Lever
- Stainless Steel Locking Lever
- Memory Stop
- Extended Lever w/ Memory Stop
- Round
- Wing
- Horizontal and Vertical Chain

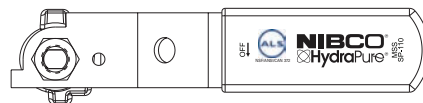

Handle Markings

## DIMENSIONS—WEIGHTS—QUANTITIES

SIZE	A		B		C		D		E		F		G		Weight		
	In.	mm.	In.	mm.	In.	mm.	In.	mm.	In.	mm.	In.	mm.	In.	mm.	Lbs.	Kg.	
1/2	15	3.61	92	3.76	96	1.96	50	0.50	13	5.93	151	1.53	39	0.70	18	12.70	0.42
3/4	20	4.32	110	4.76	121	2.28	58	0.75	19	7.28	185	1.95	50	0.96	24	1.70	0.77

NIBCO Press end ball valves are designed to MSS SP-110 with the exception of Press connections are designed to MSS SP-145. Valves with Press ends are rated to align with NIBCO Press System max pressure.

**WARNING:** This product can expose you to chemicals including lead, which is known to the State of California to cause cancer and birth defects or other reproductive harm. For more information go to [www.P65Warnings.ca.gov](http://www.P65Warnings.ca.gov).

Visit our website for the most current information.

LEAD-FREE: Weighted average lead content ≤ 0.25%

# NIBCO® Press System Lead-Free Bronze Ball Valves

**Features:** Silicon Performance Bronze® Alloy • Two-Piece Body • Full Port • Stainless Trim • Blowout-Proof Stem • Copper Ends x 3/4" Hose Connection with Cap

**Approvals:** MSS SP-110/145 • IAPMO/ANSI Z1157 • NSF/ANSI/CAN 61-8 & 372

**Size range:** 1/2" & 3/4"

**Pressure rating:** 250 PSI non-shock cold working pressure

Lead-free markings: Double oval in body casting, white handle and blue hang tag



## MATERIAL LIST

PART	SPECIFICATION
1. Handle Nut	Zinc Plated Steel
2. Stem	Stainless Steel ASTM A276 Type 316
3. Pack Gland	Brass ASTM B16 Alloy C36000
4. Packing	PTFE
5. Thrust Washer	Reinforced PTFE
6. Handle Assembly	Zinc Plated Steel with Plastisol Coating
7. Hose Body End	Silicon Bronze ASTM B371 Alloy C69300
8. Ball (vented)	Stainless Steel ASTM A276 Type 316
9. Seat Ring (2)	Reinforced PTFE
10. Body	Silicon Bronze ASTM B584 Alloy C87600
11. Boss seal o-ring	EPDM
12. Crimp Evident Seal	EPDM - Leak Detection
13. Press End Adapter	Wrot Copper ASTM B75 Alloy C12200
14. Hose Cap Assembly <sup>1</sup>	Die Cast Brass, EPDM Gasket, Soft PVC Retainer

<sup>1</sup> Cap is for hose end thread protection only. Not to be used for pressure containing purposes.



**PC-585-66-LF-HC**  
Press Female x Hose End

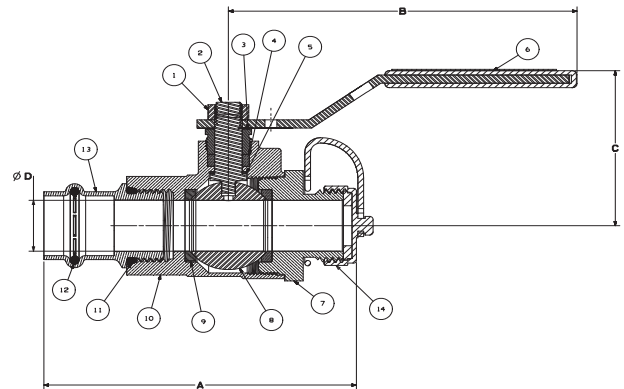

**PC-585-66-LF-HC**  
P x Hose

### Handle Options:

- Stainless Steel Lever
- NIB-SEAL®
- Locking Lever
- Stainless Steel Locking Lever
- Memory Stop
- Extended Lever w/ Memory Stop
- Round
- Wing
- Horizontal and Vertical Chain

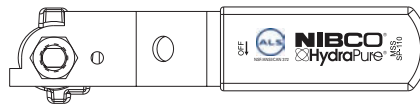

Handle Markings

## DIMENSIONS—WEIGHTS—QUANTITIES

SIZE	A		B		C		D		E		F		G		Weight		
	In.	mm.	In.	mm.	In.	mm.	In.	mm.	In.	mm.	In.	mm.	In.	mm.	Lbs.	Kg.	
1/2	15	3.61	92	3.76	96	1.96	50	0.50	13	5.93	151	1.31	33	0.70	18	0.92	0.42
3/4	20	4.32	110	4.76	121	2.28	58	0.75	19	7.28	185	1.62	41	0.96	24	1.70	0.77

NIBCO Press end ball valves are designed to MSS SP-110 with the exception of Press connections are designed to MSS SP-145. Valves with Press ends are rated to align with NIBCO Press System max pressure.

**WARNING:** This product can expose you to chemicals including lead, which is known to the State of California to cause cancer and birth defects or other reproductive harm. For more information go to [www.P65Warnings.ca.gov](http://www.P65Warnings.ca.gov).

LEAD-FREE: Weighted average lead content ≤ 0.25%

Visit our website for the most current information.

# NIBCO® Press System Lead-Free Bronze Ball Valves

**Features:** Silicon Performance Bronze® Body • Press Ends Leak Detection • Full Port • Blowout-Proof Stem

**Approvals:** MSS SP-110 • IAPMO/ANSI Z1157 (IGC-157) • NSF/ANSI/CAN 61-8 Commercial Hot 180°F and NSF/ANSI/CAN 372

**Pressure rating: 250 psi non-shock cold working pressure**  
**Body design pressure: 600 psi non-shock cold working pressure**  
**Maximum pressure / temperature: 225 psi at 250° F**

Lead-Free markings: Double oval in body casting, white handle and blue hang tag



## MATERIAL LIST

PART	SPECIFICATION
1. Handle Nut	Zinc Plated Steel
2. Stem	Silicon Bronze ASTM B371 Alloy C69300
3. Pack Gland	Brass ASTM B16 Alloy C36000
4. Packing, Stem	PTFE
5. Thrust Washer	Reinforced PTFE
6. Handle Assembly	Zinc Plated Steel Clear Chromate Plastisol Coated
7. Body End	Silicon Bronze ASTM B584 Alloy C87600
8. Seat Ring (2)	Reinforced PTFE
9. Ball	Silicon Bronze ASTM B283 Alloy C69300 or SAE J461 C46500 (1/2" - 1") Silicon Bronze ASTM B283 Alloy C69300 or ASTM A276, Alloy S31600 (1 1/4" - 2")
10. Body	Silicon Bronze ASTM B584 Alloy C87600
11. Boss seal o-ring	EPDM
12. Crimp Evident Seal	EPDM - Leak Detection
13. Press End Adapter	Wrot Copper ASTM B75 Alloy C12200



**TPC-585-80-LF**  
Thread x Press  
Female

- Handle Options:**
- Stainless steel lever
  - NIB-SEAL®
  - Locking lever
  - Stainless steel locking lever
  - Memory stop
  - Extended lever w/ memory stop
  - Round
  - Wing
  - Horizontal and vertical chain

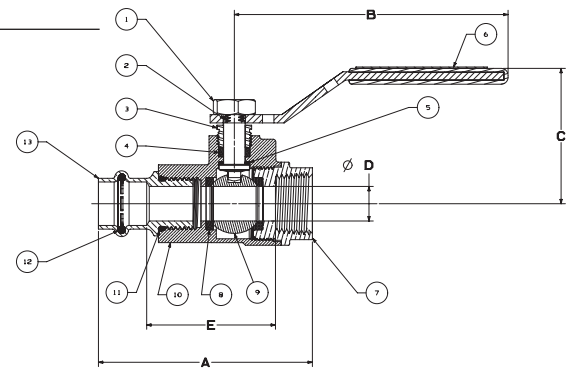

**TPC-585-80-LF**  
NPT x P

## DIMENSIONS—WEIGHTS

NOM SIZE	A		B		C		D		E		F		G		J		Weight		Master Ctn. Qty.	
	In.	mm.	In.	mm.	In.	mm.	In.	mm.	In.	mm.	In.	mm.	Lbs.	Kg.	Lbs.	Kg.	Lbs.	Kg.		
1/2	15	3.1	79	3.96	101	1.96	50	0.5	13	1.86	47	1.2	30	0.7	18	5.93	151	0.80	0.36	50
3/4	20	3.96	101	4.76	121	2.28	58	0.75	19	2.45	62	1.56	40	0.96	24	7.33	186	1.35	0.61	30
1	25	4.47	114	4.76	121	2.48	63	1	25	2.92	74	1.97	50	0.89	23	7.56	192	1.90	0.86	20
1-1/4	32	4.99	127	6.76	172	3.1	79	1.25	32	3.3	84	2.31	59	1.01	26	9.86	250	3.20	1.45	12
1-1/2	40	5.9	150	6.76	172	3.32	84	1.5	38	3.84	98	2.84	72	1.39	35	10.53	267	4.40	2.00	6
2	50	6.61	168	6.76	172	3.56	90	2	51	4.38	111	3.54	90	1.51	38	10.94	278	6.45	2.93	6

NIBCO Press end ball valves are designed to MSS SP-110 with the exception of Press connections are designed to MSS SP-145. Valves with Press ends are rated to align with NIBCO Press System max pressure.

**WARNING:** This product can expose you to chemicals including lead, which is known to the State of California to cause cancer and birth defects or other reproductive harm. For more information go to [www.P65Warnings.ca.gov](http://www.P65Warnings.ca.gov).

Visit our website for the most current information.

LEAD-FREE: Weighted average lead content ≤ 0.25%

# NIBCO® Press System Lead-Free Bronze Ball Valves

**Features:** Silicon Performance Bronze® Body • Copper End • Full Port • Blowout-Proof Stem • Stainless Trim

**Approvals:** MSS SP-145 • IAPMO/ANSI Z1157 (IGC-157) • NSF/ANSI/CAN 61-8 Commercial Hot 180°F and NSF/ANSI/CAN 372

**Pressure rating:** 250 psi non-shock cold working pressure

**Body design pressure:** 600 psi CWP

**Maximum pressure / temperature:** 225 psi at 250° F

Lead-Free markings: Double oval in body casting, white handle and blue hang tag



## MATERIAL LIST

PART	SPECIFICATION
1. Handle Nut	Plated Steel
2. Stem	Stainless Steel ASTM A276 Type 316
3. Pack Gland	Brass ASTM B16 Alloy C36000
4. Packing, Stem	PTFE
5. Thrust Washer	Reinforced PTFE
6. Handle Assembly	Plated Steel with Plastisol Coating
7. Body End	Silicon Bronze ASTM B584 Alloy C87600
8. Seat Ring (2)	Reinforced PTFE
9. Ball (vented)	Stainless Steel ASTM A276 Type 316
10. Body	Silicon Bronze ASTM B584 Alloy C87600
11. Boss seal o-ring	EPDM
12. Crimp Evident Seal	EPDM - Leak Detection
13. Press End Adapter	Wrot Copper ASTM B75 Alloy C12200



**TPC-585-66-LF**

Thread x Press  
Female

### Handle Options:

- Stainless Steel Lever
- NIB-SEAL®
- Locking lever
- Stainless Steel Locking Lever
- Memory stop
- Extended lever w/ memory stop
- Round
- Wing
- Horizontal and vertical chain



Handle Markings

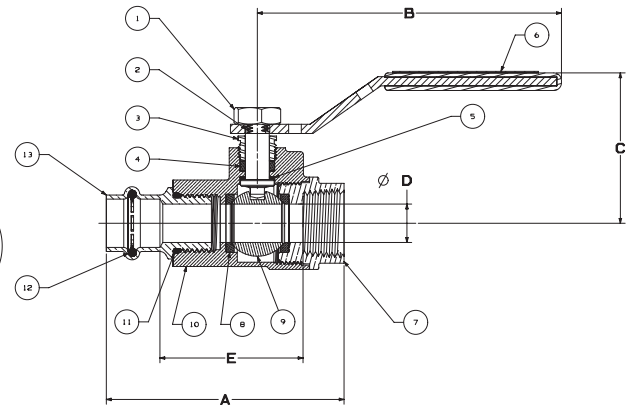

**TPC-585-66-LF**  
NPT x P

## DIMENSIONS—WEIGHTS

NOM SIZE	A		B		C		D		E		F		G		J		Weight		Master Ctn. Qty.	
	In.	mm.	In.	mm.	In.	mm.	In.	mm.	In.	mm.	In.	mm.	Lbs.	Kg.	Lbs.	Kg.	Lbs.	Kg.		
1/2	15	3.1	79	3.96	101	1.96	50	0.5	13	1.86	47	1.2	30	0.7	18	5.93	151	0.80	0.36	50
3/4	20	3.96	101	4.76	121	2.28	58	0.75	19	2.45	62	1.56	40	0.96	24	7.33	186	1.35	0.61	30
1	25	4.47	114	4.76	121	2.48	63	1	25	2.92	74	1.97	50	0.89	23	7.56	192	1.90	0.86	20
1-1/4	32	4.99	127	6.76	172	3.1	79	1.25	32	3.3	84	2.31	59	1.01	26	9.86	250	3.20	1.45	12
1-1/2	40	5.9	150	6.76	172	3.32	84	1.5	38	3.84	98	2.84	72	1.39	35	10.53	267	4.40	2.00	6
2	50	6.61	168	6.76	172	3.56	90	2	51	4.38	111	3.54	90	1.51	38	10.94	278	6.45	2.93	6

NIBCO Press end ball valves are designed to MSS SP-110 with the exception of Press connections are designed to MSS SP-145. Valves with Press ends are rated to align with NIBCO Press System max pressure.

**WARNING:** This product can expose you to chemicals including lead, which is known to the State of California to cause cancer and birth defects or other reproductive harm. For more information go to [www.P65Warnings.ca.gov](http://www.P65Warnings.ca.gov).

LEAD-FREE: Weighted average lead content ≤ 0.25%

Visit our website for the most current information.

**NEW Lead-Free Bronze Ball Valves with Spring Return Handle**

Spring Return Handle to Close • Press Ends Leak Detection • Silicon Performance Bronze® Alloy • Two-Piece Body • Full Port • Blowout-Proof Stem

**250 PSI/17 bar non-shock cold working pressure**  
**Maximum pressure / temperature: 225 psi at 250° F**

Lead-free markings: Double oval in body casting, white handle and blue hang tag  
MSS SP-110/145 • NSF/ANSI/CAN 61-8 COMMERCIAL HOT 180° F • NSF/ANSI/CAN 372



**MATERIAL LIST**

PART	SPECIFICATION
1. Body	ASTM B584 C87600 DZR Lead-free Silicon Bronze Casting
2. Body End Piece	ASTM B584 C87600 DZR Lead-free Silicon Bronze Casting
3. Seats (2)	Reinforced PTFE
4. Ball (Vented)	ASTM B584 C46500 DZR Lead-free Brass (1/2" - 1") ASTM A276 S31600 or A351 CF8M Stainless Steel (1 1/4" - 2")
5. Stem	ASTM B371 C69300 Lead-free Silicon Bronze
6. Thrust Washer	Reinforced PTFE
7. Stem Packing	Virgin PTFE
8. Threaded Pack Gland	Brass ASTM B16 Alloy C36000
9. Handle assembly	Stainless Steel Type 316 and 304 with Plastisol Cover
10. Lock Washer	Stainless Steel
11. Handle Nut	Stainless Steel
12. Mounting Plate	Stainless Steel ASTM A351 Type CF8M
13. Socket Head Cap Screw (2)	Stainless Steel Type 304
14. Hex Shoulder Bolt	Stainless Steel
15. Press End Adapter (2)	ASTM B75 Alloy C12200 Wrot Copper
16. Boss Seal O-ring (2)	EPDM
17. Crimp Evident Seal (2)	EPDM - Leak Detection

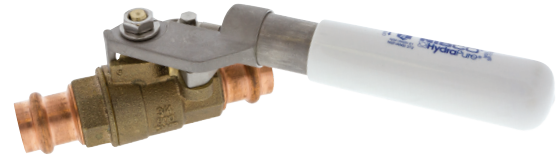

**PC-585-80-LF-SR**  
Press x Press

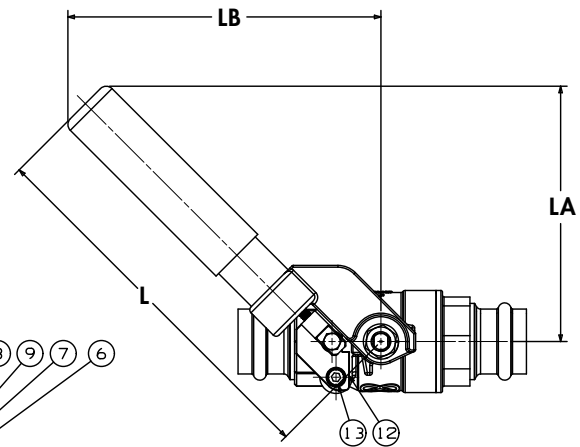

**PC-585-80-LF-SR**  
Press x Press

**Carbon Steel and Stainless Steel Ball Valve options available. See Ball Valve Catalog.**

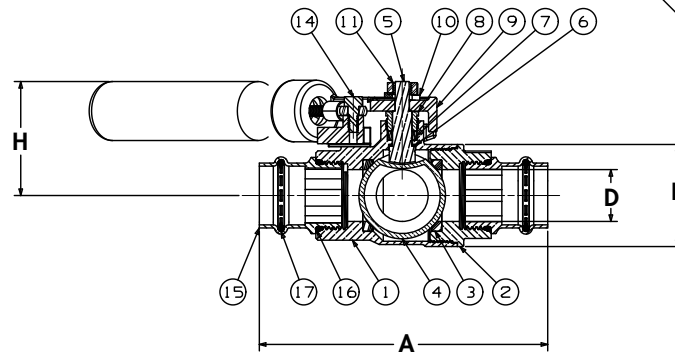

**DIMENSIONS—WEIGHTS**

Size	Dimensions														Lbs.	Kg	
	A		B		D		H		L		LA		LB				
In.	mm.	In.	mm.	In.	mm.	In.	mm.	In.	mm.	In.	mm.	In.	mm.	In.	mm.		
1/2	12.70	3.95	100	1.57	40	0.50	13	1.73	44	7.11	181	4.84	123	5.79	147	1.43	0.65
3/4	19.05	5.10	130	2.00	51	0.75	19	2.01	51	7.28	185	4.92	125	6.04	153	2.16	0.98
1	25.40	5.56	141	1.97	50	1.00	25	2.22	56	7.28	185	4.92	125	6.04	153	2.76	1.25
1 1/4	31.75	6.23	158	2.31	59	1.25	32	2.69	68	9.51	242	6.50	165	7.62	194	4.43	2.01
1 1/2	38.10	7.55	192	2.84	72	1.50	38	2.91	74	9.51	242	6.50	165	7.62	194	5.33	2.42
2	50.80	8.38	213	3.54	90	2.00	51	3.15	80	9.51	242	6.50	165	7.62	194	7.63	3.46

NIBCO Press end ball valves are designed to MSS SP-110 with the exception of Press connections are designed to MSS SP-145. Valves with Press ends are rated to align with NIBCO Press System max pressure.

**WARNING:** This product can expose you to chemicals including lead, which is known to the State of California to cause cancer and birth defects or other reproductive harm. For more information go to [www.P65Warnings.ca.gov](http://www.P65Warnings.ca.gov).

Visit our website for the most current information.

LEAD-FREE: Weighted average lead content ≤ 0.25%

# NEW Lead-Free Bronze Ball Valves with Spring Return Handle

Spring Return Handle to Close • Press End Leak Detection • 3/4" Hose Connection w/ Cap • Silicon Performance Bronze® Alloy • Two-Piece Body • Full Port • Blowout-Proof Stem

**250 PSI/17 bar non-shock cold working pressure**

Lead-free markings: Double oval in body casting, white handle and blue hang tag

MSS SP-110/145 • NSF/ANSI/CAN 61-8 COMMERCIAL HOT 180° F • NSF/ANSI/CAN 372



## MATERIAL LIST

PART	SPECIFICATION
1. Body	ASTM B584 C87600 DZR Lead-free Silicon Bronze Casting
2. Body End Piece	ASTM B371 C69300
3. Seats (2)	Reinforced PTFE
4. Ball (Vented)	ASTM B584 C46500 DZR Lead-free Brass
5. Stem	ASTM B371 C69300 Lead-free Silicon Bronze
6. Thrust Washer	Reinforced PTFE
7. Stem Packing	Virgin PTFE
8. Threaded Pack Gland	Brass ASTM B16 Alloy C36000
9. Handle assembly	Stainless Steel Type 316 and 304 with Vinyl Cover
10. Lock Washer	Stainless Steel
11. Handle Nut	Stainless Steel
12. Mounting Plate	Stainless Steel ASTM A351 Type CF8M
13. Socket Head Cap Screw (2)	Stainless Steel Type 304
14. Hex Shoulder Bolt	Stainless Steel
15. Press End Adapter	ASTM B75 Alloy C12200 Wrot Copper
16. Boss Seal O-ring	EPDM
17. Crimp Evident Seal	EPDM - Leak Detection
18. Hose cap Assembly <sup>1</sup>	Die Cast Brass, EPDM Gasket, Soft PVC Retainer



**PC-585-80-LF-HC-SR**

Press x Hose

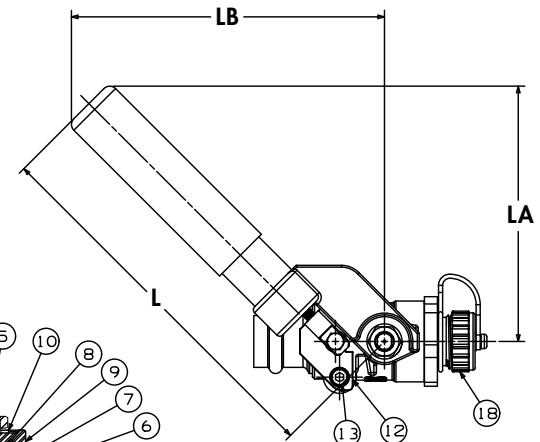

**PC-585-80-LF-HC-SR**

Press x Hose

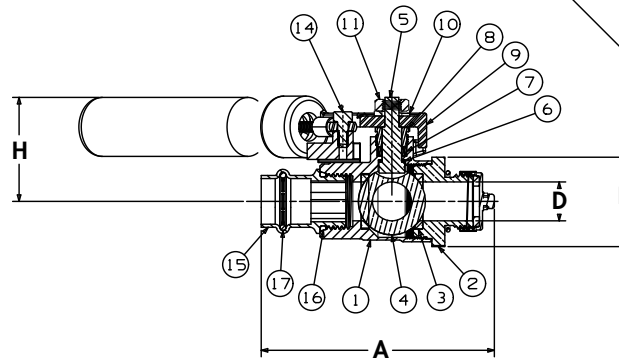

Carbon Steel and Stainless Steel Ball Valve options available. See Ball Valve Catalog.

<sup>1</sup> Cap is for hose end thread protection only. Not to be used for pressure containing purposes.

## DIMENSIONS—WEIGHTS

Size	Dimensions														Lbs.	Kg	
	A		B		D		H		L		LA		LB				
In.	mm.	In.	mm.	In.	mm.	In.	mm.	In.	mm.	In.	mm.	In.	mm.	In.	mm.		
1/2	12.70	3.82	97	1.57	40	0.50	13	1.73	44	7.11	181	4.84	123	5.79	147	1.38	0.63
3/4	19.05	4.50	114	2.00	51	0.75	19	2.90	74	7.28	185	4.92	125	6.04	153	2.11	0.96

NIBCO Press end ball valves are designed to MSS SP-110 with the exception of Press connections are designed to MSS SP-145. Valves with Press ends are rated to align with NIBCO Press System max pressure.

**WARNING:** This product can expose you to chemicals including lead, which is known to the State of California to cause cancer and birth defects or other reproductive harm. For more information go to [www.P65Warnings.ca.gov](http://www.P65Warnings.ca.gov).

LEAD-FREE: Weighted average lead content ≤ 0.25%

Visit our website for the most current information.

# NIBCO® Press Lead-Free Three Piece Bronze Ball Valves

**Features:** Silicon Performance Bronze® Alloy • Three-Piece Body • Press Ends Leak Detection • Full Port • Blowout-Proof Stem

**Approvals:** MSS SP-110/145 • NSF/ANSI/CAN 61-2018 Commercial Hot 180°F, NSF/ANSI/CAN 372

**Size range:** 1/2" - 2-1/2"

**Pressure rating:** 250 psi non-shock cold working pressure\*

**Maximum pressure / temperature:** 225 psi at 250° F\*

Lead-free markings: Double oval in body casting, white handle and blue hang tag



NSF/ANSI/CAN 372



## MATERIAL LIST

PART	SPECIFICATION
1. Body Nuts	Zinc Dichromate Plated Steel ASTM A449 Grade 5
2. Handle Nut	Zinc Plated Steel
3. Threaded Pack Gland	Brass ASTM B16 Alloy C36000
4. Body	Silicon Bronze ASTM B584 Alloy C87850
5. Body End (2)	Silicon Bronze ASTM B584 Alloy C87850
6. Handle	Steel, Plated Plastisol Coated DZR Brass SAE J461 C46500 (1/4"-1")
7. Ball	Stainless Steel ASTM A276 S31600 or ASTM A351 CF8M (1 1/4"-2 1/2")
8. Seats (2)	PTFE "Y" or RPTFE "R" Glass Reinforced
9. Body Bolts	Zinc Dichromate Plated Steel ASTM A449 Grade 5
10. O-ring (2)	FKM
11. Grounding Washer	Stainless Steel- ASTM A-167 304
12. Thrust Washer	Reinforced PTFE
13. Stem Packing	PTFE
14. Stem	Silicon Bronze ASTM B371 Alloy C69300
15. Press End Adapter (2)	Wrot Copper ASTM B75 Alloy C12200
16. Crimp Evident Seal (2)	EPDM - Leak Detection
17. Boss Seal O-ring (2)	EPDM

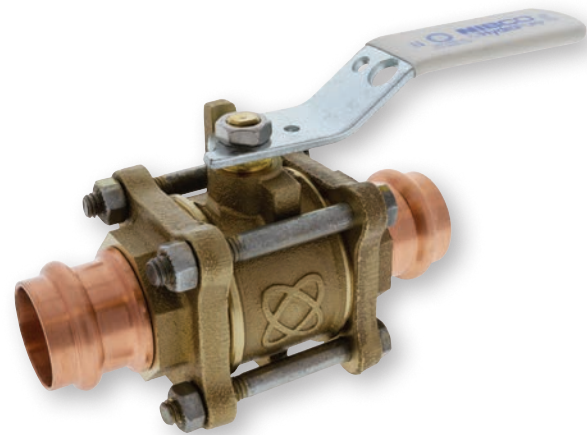

**PC-595-Y-LF**  
**PC-595-R-LF**

Press

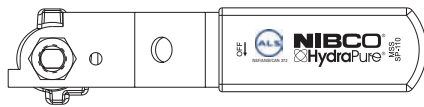
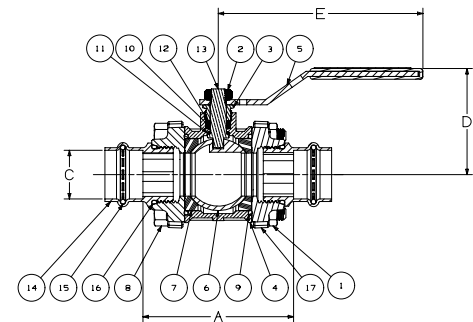
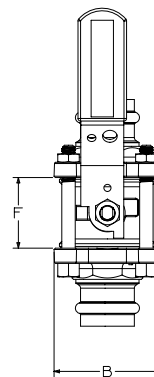

Handle Markings

## DIMENSIONS - WEIGHTS - QUANTITIES

Size	A		B		C		D		E		F		Weights		Master Ctn. Qty.
	In.	mm.	In.	mm.	In.	mm.	In.	mm.	In.	mm.	In.	mm.	lbs.	kg	
1/2"	2.482	63	1.794	46	0.629	16	1.942	49	3.96	101	0.968	25	1.14	0.52	40
3/4"	3.048	77	1.991	51	0.881	22	2.277	58	4.762	121	1.281	33	1.91	0.87	25
1"	3.505	89	2.484	63	1.132	29	2.469	63	4.762	121	1.643	42	2.84	1.29	15
1 1/4"	3.758	95	2.718	69	1.382	35	3.092	79	6.75	171	1.83	46	4.36	1.98	10
1 1/2"	4.24	108	3.045	77	1.633	41	3.335	85	6.75	171	2.205	56	5.73	2.60	8
2"	6.404	163	4.042	103	2.134	54	3.556	90	6.75	171	2.72	69	11.12	5.04	4
2 1/2"	7.071	180	5.09	129	2.631	67	4.322	110	8.06	205	3.513	89	18.79	8.52	2

\*200 PSI CWP and 200 PSI at 200°F for 2 1/2" and above

NIBCO Press end ball valves are designed to MSS SP-110 with the exception of Press connections are designed to MSS SP-145. Valves with Press ends are rated to align with NIBCO Press System max pressure.

**WARNING:** This product can expose you to chemicals including lead, which is known to the State of California to cause cancer and birth defects or other reproductive harm. For more information go to [www.P65Warnings.ca.gov](http://www.P65Warnings.ca.gov).

Visit our website for the most current information.

LEAD-FREE: Weighted average lead content ≤ 0.25%

# NIBCO® Press Lead-Free Three Piece Bronze Ball Valves

**Features:** Silicon Performance Bronze® Alloy • Three-Piece Body • Press Ends Leak Detection • Stainless Steel Trim • Full Port • Blowout-Proof Stem

**Approvals:** MSS SP-110/145 • NSF/ANSI/CAN 61-2018 Commercial Hot 180°F, NSF/ANSI/CAN 372

**Size range:** 1/2" - 2-1/2"

**Pressure rating:** 250 psi non-shock cold working pressure\*

**Maximum pressure / temperature:** 225 psi at 250° F\*

Lead-free markings: Double oval in body casting, white handle and blue hang tag



NSF/ANSI/CAN 372



## MATERIAL LIST

PART	SPECIFICATION
1. Body Nuts	Zinc Dichromate Plated Steel ASTM A449 Grade 5
2. Handle Nut	Zinc Plated Steel
3. Threaded Pack Gland	Brass ASTM B16 Alloy C36000
4. Body	Silicon Bronze ASTM B584 Alloy C87850
5. Body End (2)	Silicon Bronze ASTM B584 Alloy C87850
6. Handle	Steel, Plated Plastisol Coated
7. Ball	Stainless Steel ASTM A276 Type S31600
8. Seats (2)	PTFE "Y" or RPTFE "R" Glass Reinforced
9. Body Bolts	Zinc Dichromate Plated Steel ASTM A449 Grade 5
10. O-ring (2)	FKM
11. Grounding Washer	Stainless Steel- ASTM A-167 304
12. Thrust Washer	Reinforced PTFE
13. Stem Packing	PTFE
14. Stem	Stainless Steel ASTM A276 Type 316
15. Press End Adapter (2)	Wrot Copper ASTM B75 Alloy C12200
16. Crimp Evident Seal (2)	EPDM - Leak Detection
17. Boss Seal O-ring (2)	EPDM

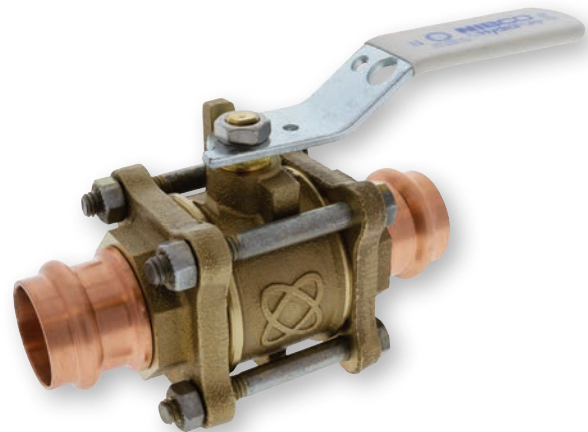

**PC-595-Y-66-LF**  
**PC-595-R-66-LF**

Press

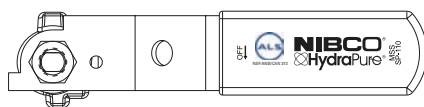
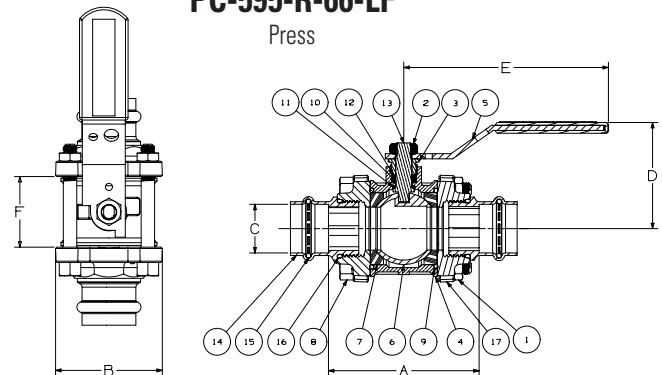

Handle Markings

## DIMENSIONS - WEIGHTS - QUANTITIES

Size	A		B		C		D		E		F		Weights		Master Ctn. Qty.
	In.	mm.	In.	mm.	In.	mm.	In.	mm.	In.	mm.	In.	mm.	lbs.	kg	
1/2"	2.482	63	1.794	46	0.629	16	1.942	49	3.96	101	0.968	25	1.14	0.52	40
3/4"	3.048	77	1.991	51	0.881	22	2.277	58	4.762	121	1.281	33	1.91	0.87	25
1"	3.505	89	2.484	63	1.132	29	2.469	63	4.762	121	1.643	42	2.84	1.29	15
1 1/4"	3.758	95	2.718	69	1.382	35	3.092	79	6.75	171	1.83	46	4.36	1.98	10
1 1/2"	4.24	108	3.045	77	1.633	41	3.335	85	6.75	171	2.205	56	5.73	2.60	8
2"	6.404	163	4.042	103	2.134	54	3.556	90	6.75	171	2.72	69	11.12	5.04	4
2 1/2"	7.071	180	5.09	129	2.631	67	4.322	110	8.06	205	3.513	89	18.79	8.52	2

\*200 PSI CWP and 200 PSI at 200°F for 2 1/2" and above

NIBCO Press end ball valves are designed to MSS SP-110 with the exception of Press connections are designed to MSS SP-145. Valves with Press ends are rated to align with NIBCO Press System max pressure.

**WARNING:** This product can expose you to chemicals including lead, which is known to the State of California to cause cancer and birth defects or other reproductive harm. For more information go to [www.P65Warnings.ca.gov](http://www.P65Warnings.ca.gov).

LEAD-FREE: Weighted average lead content ≤ 0.25%

Visit our website for the most current information.

# NIBCO® Press System Lead-Free Brass Ball Valves

**Features:** Press Ends Leak Detection • Two-Piece Body • PTFE Seats • Full Port • Blowout-Proof Stem

**Approvals:** IAPMO/ANSI Z1157 (IGC-157) • NSF/ANSI/CAN-61 & 372 • MSS SP-145 • Conforms to ASME B16.51†

**Size range:** 1/2" - 2"

**Pressure rating:** 250 psi non-shock cold working pressure

**Maximum pressure / temperature:** 225 psi at 250° F

Lead-Free markings: White handle and blue hang tag

**Applications:** Drinking Water • Domestic Hot & Cold Water • HVAC (condensers, chilled water, hot water heating) • Isolation and Throttling (half-open to full-open only) • Connect to Rigid Copper Tubing Manufactured per ASTM B88, Condition H (hard drawn)

Reference Press System catalog for updated Approved Tool and Jaw Compatibility Matrix list.

**Not intended for steam or gas usage.**

## MATERIAL LIST

PART	SPECIFICATION
1. Body	Forged DZR Copper Alloy - C46500
2. Seat (2)	PTFE
3. O-ring	EPDM
4. Packing	PTFE
5. Packing Nut	Brass
6. Lock Washer	Stainless Steel ASTM 321
7. Handle Nut	Stainless Steel 304
8. Handle	Carbon Steel, Plated
9. Stem	Brass
10. Handle	Chrome Plated Brass - C46500 (1/2 - 1") Stainless Steel 316 (1 1/4" - 2")
11. Body End Piece	Forged DZR Copper Alloy - C46500
12. Press O-ring (2)	EPDM - Leak Detection
13. Metal Ring (4)	Stainless Steel (1 1/4"-2")

### Options:

- Extended lever
- EPDM Seal for Press Ends
- Wing Handle
- Mini Flat



Handle Markings

## DIMENSIONS—WEIGHTS—QUANTITIES

SIZE	A		B		C		D		E		F		Weight	
	In.	mm.	In.	mm.	In.	mm.	In.	mm.	In.	mm.	In.	mm.	Lbs.	Kg.
1/2	4.57	116	3.66	93	2.09	53	0.631	16.03	1.30	33.0	2.87	73.0	0.38	0.17
3/4	5.71	145	4.17	106	2.80	71	0.883	22.43	1.63	41.5	3.44	87.5	0.73	0.33
1	5.83	148	4.17	106	3.15	80	1.140	28.96	1.83	46.5	3.64	92.5	1.00	0.46
1-1/4†	6.97	177	4.61	117	2.52	64	1.386	35.20	2.19	55.5	4.43	112.5	1.70	0.77
1-1/2†	9.06	230	6.30	160	3.23	82	1.636	41.56	2.52	64.0	5.30	134.5	2.37	1.08
2†	9.88	251	6.30	160	3.23	82	2.137	54.28	3.39	86.0	6.69	170.0	3.96	1.80

**IAPMO/ANSI Z1157:** in addition to meeting Z1157 ball valve performance requirements, this product standard also requires Press ends to be fully tested to IAPMO PS-117 performance requirements which includes the following additional tests:

- |  |  |
|--|--|
| 1. Unrestrained Hydrostatic Pressure Test at 20 °C (68°F)  | 6. Hydraulic Shock (Water Hammer) Test         |
| 2. Unrestrained Hydrostatic Pressure Test at 93 °C (200°F) | 7. Vibration Test                              |
| 3. Static Torsion Test for Press Connections               | 8. Thermal Cycling Test                        |
| 4. Bending Test  | 9. Alternate Thermal Cycling Test              |
| 5. Vacuum Test   | 10. Dynamic Torsion Test for Press Connections |

**WARNING:** This product can expose you to chemicals including lead, which is known to the State of California to cause cancer and birth defects or other reproductive harm. For more information go to [www.P65Warnings.ca.gov](http://www.P65Warnings.ca.gov).

Visit our website for the most current information.

†Tested to the performance criteria of ASME B16.51

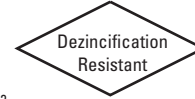

**PC-FP-600A-LF**

Press x Press

1/2" - 2"

Patent US 10,240,698; Sizes 1-1/4" - 2"

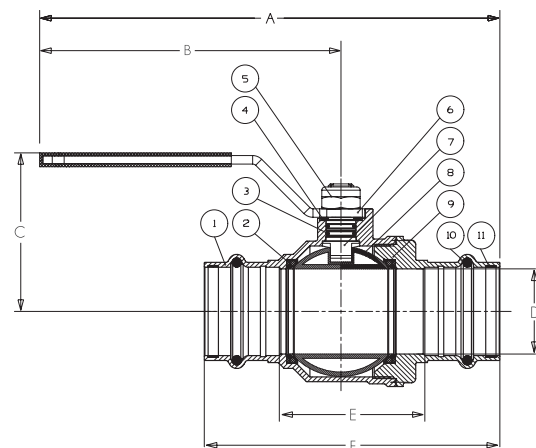

**PC-FP-600A-LF**

Press x Press

1/2" - 2"

LEAD-FREE: Weighted average lead content ≤ 0.25%

# NIBCO® Press System Lead-Free Brass Ball Valves

**Features:** Press Ends Leak Detection • Two-Piece Body • PTFE Seats • Full Port • Blowout-Proof Stem

**Approvals:** IAPMO/ANSI Z1157 (IGC-157) • NSF/ANSI/CAN-61 & 372 • MSS SP-145 • Conforms to ASME B16.51†

**Size range:** 2 1/2" - 4"

**Pressure rating:** 200 psi non-shock cold working pressure

**Maximum pressure / temperature:** 200 psi at 200° F

Lead-Free markings: White handle and blue hang tag

**Applications:** Drinking Water • Domestic Hot & Cold Water • HVAC (condensors, chilled water, hot water heating) • Isolation and Throttling (half-open to full-open only) • Connect to Rigid Copper Tubing Manufactured per ASTM B88, Condition H (hard drawn)

Reference Press System catalog for updated Approved Tool and Jaw Compatibility Matrix list.

**Not intended for steam or gas usage.**



**PC-FP-600A-LF**

Press x Press  
2 1/2" - 4"

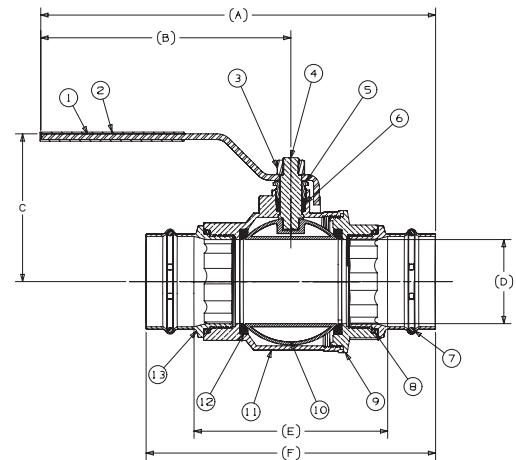

**PC-FP-600A-LF**

Press x Press  
2 1/2" - 4"

## MATERIAL LIST

PART	SPECIFICATION
1 Handle	Steel Plated
2 Handle Cover	PVC
3 Handle Nut	Steel
4 Stem	Brass/Bronze
5 Packing Nut	Brass/Bronze
6 Packing	PTFE
7 Crimp Evident Seal (2)	EPDM - Lead Detection
8 Boss Seal O-ring (2)	EPDM
9 Body End	Brass/Bronze
10 Ball	Stainless Steel
11 Body	Brass/Bronze
12 Seat Ring (2)	PTFE
13 Press End Adaptor (2)	ASTM B75 Alloy C12200

### Options:

- Extended lever



Handle Markings

## DIMENSIONS—WEIGHTS—QUANTITIES

SIZE		A		B		C		D		E		F		Weight	
In.	mm.	In.	mm.	In.	mm.	In.	mm.	In.	mm.	In.	mm.	In.	mm.	Lbs.	Kg.
2 1/2"	15	13.07	332	8.66	220	4.8	121.9	2.52	64	5.88	149.3	8.81	223.7	9.55	4.33
3	20	13.67	347.2	8.66	220	5.12	130	2.91	73.9	6.71	170.4	10.03	261.6	13.07	5.93
4	25	15.87	403.1	9.61	244.1	5.98	151.9	3.9	99	8.21	208.5	12.53	318.2	26.32	11.94

In addition to meeting IGC-157 test requirements, the IAPMO/ANSI Z1157 also requires Press ends to be fully tested to IAPMO PS-117 performance requirements which includes the following additional tests:

- Unrestrained Hydrostatic Pressure Test at 20 °C (68°F)
- Unrestrained Hydrostatic Pressure Test at 93 °C (200°F)
- Static Torsion Test for Press Connections
- Bending Test
- Vacuum Test
- Hydraulic Shock (Water Hammer) Test
- Vibration Test
- Thermal Cycling Test
- Alternate Thermal Cycling Test
- Dynamic Torsion Test for Press Connections

†Tested to the performance criteria of ASME B16.51

**WARNING:** This product can expose you to chemicals including lead, which is known to the State of California to cause cancer and birth defects or other reproductive harm. For more information go to [www.P65Warnings.ca.gov](http://www.P65Warnings.ca.gov).

LEAD-FREE: Weighted average lead content ≤ 0.25%

Visit our website for the most current information.

# NIBCO® Press System Lead-Free Brass Ball Valves

**Features:** Press Ends Leak Detection • Wing Handle • Two-Piece Body • PTFE Seats • Full Port • Blowout-Proof Stem

**Approvals:** IAPMO/ANSI Z1157 (IGC-157) • NSF/ANSI/CAN-61 & 372 • MSS SP-145 • Conforms to ASME B16.51†

**Size range:** 1/2" - 1"

**Pressure rating:** 250 psi non-shock cold working pressure

**Maximum pressure / temperature:** 225 psi at 250° F

Lead-Free markings: White handle and blue hang tag

**Applications:** Drinking Water • Domestic Hot & Cold Water • HVAC (condensors, chilled water, hot water heating) • Isolation and Throttling (half-open to full-open only) • Connect to Rigid Copper Tubing Manufactured per ASTM B88, Condition H (hard drawn)

Reference Press System catalog for updated Approved Tool and Jaw Compatibility Matrix list.

**Not intended for steam or gas usage.**

## MATERIAL LIST

PART	SPECIFICATION
1. Body	Forged DZR Copper Alloy - C46500
2. Seat Seal	PTFE
3. O-ring	EPDM - ASTM D2000
4. Washer	PTFE
5. Lock Nut	Stainless Steel + Nylon
6. Handle	Steel, Plated
7. Stem	Brass
8. Ball	Chrome Plated Brass - C46500
9. End Cap	Forged DZR Copper Alloy - C46500
10. O-ring	EPDM - ASTM D2000

### Options:

- Extended lever
- EPDM Seal for Press Ends
- Lever Handle
- Mini Flat

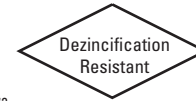
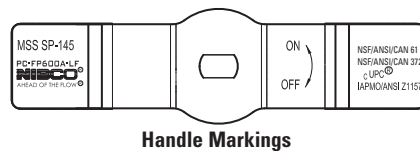

## PC-FP-600A-LF-W

Press x Press  
1/2" - 1"

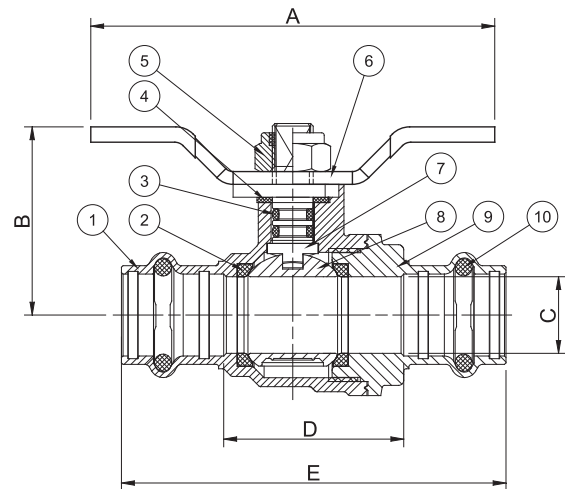

## PC-FP-600A-LF-W

Press x Press  
1/2" - 1"

## DIMENSIONS—WEIGHTS

Size		A		B		C		D		E		Weight	
In.	mm.	In.	mm.	In.	mm.	In.	mm.	In.	mm.	In.	mm.	Lbs.	Kg.
1/2	12.7	3.11	79.00	1.45	36.80	0.59	15.00	1.39	35.20	2.96	75.20	0.4230	0.1918
3/4	19.05	4.25	108.00	2.15	54.70	0.79	20.00	1.70	43.20	3.51	89.20	0.8020	0.3637
1	25.40	4.25	108.00	2.31	58.70	0.98	25.00	1.90	48.20	3.71	94.20	1.0930	0.4957

**IAPMO/ANSI Z1157:** in addition to meeting ICG-157 test requirements, the IAPMO/ANSI Z1157 also requires Press ends to be fully tested to IAPMO PS-117 performance requirements which includes the following additional tests:

†Tested to the performance criteria of ASME B16.51

- |  |  |
|--|--|
| 1. Unrestrained Hydrostatic Pressure Test at 20 °C (68°F)  | 6. Hydraulic Shock (Water Hammer) Test         |
| 2. Unrestrained Hydrostatic Pressure Test at 93 °C (200°F) | 7. Vibration Test                              |
| 3. Static Torsion Test for Press Connections               | 8. Thermal Cycling Test                        |
| 4. Bending Test  | 9. Alternate Thermal Cycling Test              |
| 5. Vacuum Test   | 10. Dynamic Torsion Test for Press Connections |

**WARNING:** This product can expose you to chemicals including lead, which is known to the State of California to cause cancer and birth defects or other reproductive harm. For more information go to [www.P65Warnings.ca.gov](http://www.P65Warnings.ca.gov).

Visit our website for the most current information.

LEAD-FREE: Weighted average lead content ≤ 0.25%

# NIBCO® Press System Lead-Free Brass Ball Valves

**Features:** Press End Leak Detection • Two-Piece Body • PTFE Seats • Full Port • Blowout-Proof Stem

**Approvals:** IAPMO/ANSI Z1157 (IGC-157) • NSF/ANSI/CAN-61 & 372 • MSS SP-145 • Conforms to ASME B16.51†

**Size range:** 1/2" - 1"

**Pressure rating:** 250 psi non-shock cold working pressure

**Maximum pressure / temperature:** 225 psi at 250° F

Lead-Free markings: White handle and blue hang tag

**Applications:** Drinking Water • Domestic Hot & Cold Water • HVAC (condensors, chilled water, hot water heating) • Isolation and Throttling (half-open to full-open only) • Connect to Rigid Copper Tubing Manufactured per ASTM B88, Condition H (hard drawn)

Reference Press System catalog for updated Approved Tool and Jaw Compatibility Matrix list.

**Not intended for steam or gas usage.**



## PCMT-FP-600A-LF

Press x MIP  
1/2" - 1"

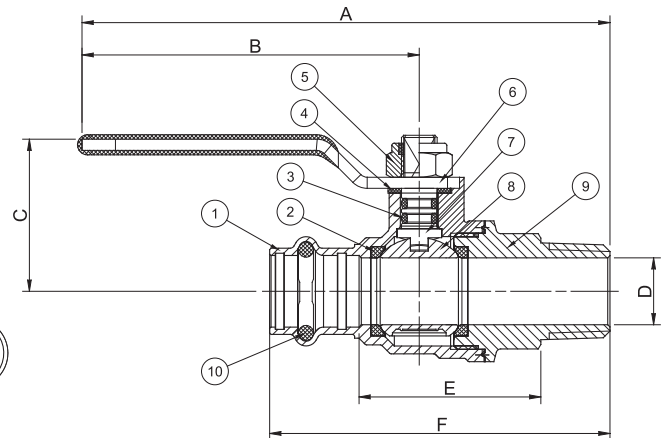

**PCMT-FP-600A-LF**  
Press x Male  
1/2" - 1"

## MATERIAL LIST

PART	SPECIFICATION
1. Body	Forged DZR Copper Alloy - C46500
2. Seat Seal	PTFE
3. O-ring	EPDM - ASTM D2000
4. Washer	PTFE
5. Lock Nut	Stainless Steel + Nylon
6. Handle	Steel, Plated
7. Stem	Brass
8. Ball	Chrome Plated Brass - C46500 (1/2"-1")
9. End Cap	Forged DZR Copper Alloy - C46500
10. O-ring	EPDM - ASTM D2000

### Options:

- Extended lever
- EPDM Seal for Press Ends
- Wing Handle
- Mini Flat



Handle Markings

## DIMENSIONS—WEIGHTS

SIZE		A		B		C		D		E		F		Weight	
In.	mm.	In.	mm.	In.	mm.	In.	mm.	In.	mm.	In.	mm.	In.	mm.	Lbs.	Kg.
1/2	12.7	5.30	134.70	3.62	92.00	1.34	34.00	0.59	15.00	1.60	40.70	3.00	76.20	0.4520	0.2050
3/4	19.05	6.07	154.20	4.13	105.00	2.06	52.20	0.79	20.00	2.00	50.70	3.53	89.70	0.7940	0.3601
1	25.40	6.29	159.70	4.13	105.00	2.21	56.20	0.98	25.00	2.23	56.70	3.89	98.70	1.1730	0.5320

IAPMO/ANSI Z1157: in addition to meeting ICG-157 test requirements, the IAPMO/ANSI Z1157 also requires Press ends to be fully tested to IAPMO PS-117 performance requirements which includes the following additional tests:

- |  |  |
|--|--|
| 1. Unrestrained Hydrostatic Pressure Test at 20 °C (68°F)  | 6. Hydraulic Shock (Water Hammer) Test         |
| 2. Unrestrained Hydrostatic Pressure Test at 93 °C (200°F) | 7. Vibration Test                              |
| 3. Static Torsion Test for Press Connections               | 8. Thermal Cycling Test                        |
| 4. Bending Test  | 9. Alternate Thermal Cycling Test              |
| 5. Vacuum Test   | 10. Dynamic Torsion Test for Press Connections |

† Tested to the performance criteria of ASME B16.51

**WARNING:** This product can expose you to chemicals including lead, which is known to the State of California to cause cancer and birth defects or other reproductive harm. For more information go to [www.P65Warnings.ca.gov](http://www.P65Warnings.ca.gov).

LEAD-FREE: Weighted average lead content ≤ 0.25%

Visit our website for the most current information.

# NIBCO® Press System Lead-Free Brass Ball Valves

**Features:** Press End Leak Detection • Two-Piece Body • PTFE Seats • Full Port • Blowout-Proof Stem

**Approvals:** IAPMO/ANSI Z1157 (IGC-157) • NSF/ANSI/CAN-61 & 372 • MSS SP-145 • Conforms to ASME B16.51†

**Size range:** 1/2" - 1"

**Pressure rating:** 250 psi non-shock cold working pressure

**Maximum pressure / temperature:** 225 psi at 250° F

Lead-Free markings: White handle and blue hang tag

**Applications:** Drinking Water • Domestic Hot & Cold Water • HVAC (condensors, chilled water, hot water heating) • Isolation and Throttling (half-open to full-open only) • Connect to Rigid Copper Tubing Manufactured per ASTM B88, Condition H (hard drawn)

Reference Press System catalog for updated Approved Tool and Jaw Compatibility Matrix list.

**Not intended for steam or gas usage.**



**PCT-FP-600A-LF**

Press x FIP  
1/2" - 1"

## MATERIAL LIST

PART	SPECIFICATION
1. Body	Forged DZR Copper Alloy - C46500
2. Seat Seal	PTFE
3. O-ring	EPDM - ASTM D2000
4. Washer	PTFE
5. Lock Nut	Stainless Steel + Nylon
6. Handle	Steel, Plated
7. Stem	Brass
8. Ball	Chrome Plated Brass - C46500
9. End Cap	Forged DZR Copper Alloy - C46500
10. O-ring	EPDM - ASTM D2000

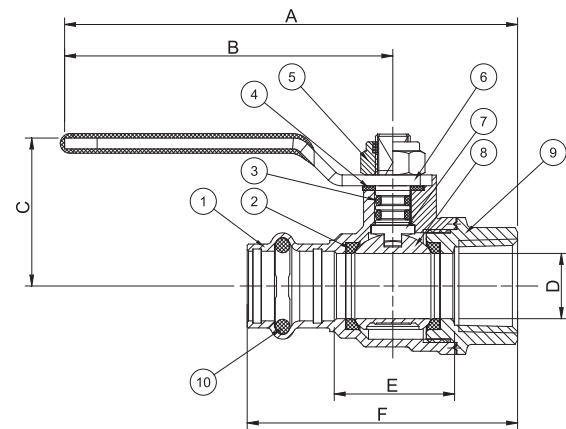

**PCT-FP-600A-LF**

Press x FIP  
1/2" - 1"

### Options:

- Extended lever
- EPDM Seal for Press Ends
- Wing Handle
- Mini Flat



**Handle Markings**

## DIMENSIONS—WEIGHTS

SIZE		A		B		C		D		E		F		Weight	
In.	mm.	In.	mm.	In.	mm.	In.	mm.	In.	mm.	In.	mm.	In.	mm.	Lbs.	Kg.
1/2	12.7	4.75	120.70	3.62	92.00	1.34	34.00	0.59	15.00	1.09	27.70	2.45	62.20	0.3950	0.1791
3/4	19.05	5.42	137.70	4.13	105.00	2.06	52.20	0.79	20.00	1.37	34.70	2.88	73.20	0.7280	0.3302
1	25.40	5.64	143.20	4.13	105.00	2.21	56.20	0.98	25.00	1.62	41.20	3.24	82.20	1.0520	0.4771

**IAPMO/ANSI Z1157:** in addition to meeting ICG-157 test requirements, the IAPMO/ANSI Z1157 also requires Press ends to be fully tested to IAPMO PS-117 performance requirements which includes the following additional tests:

†Tested to the performance criteria of ASME B16.51

- |  |  |
|--|--|
| 1. Unrestrained Hydrostatic Pressure Test at 20 °C (68°F)  | 6. Hydraulic Shock (Water Hammer) Test         |
| 2. Unrestrained Hydrostatic Pressure Test at 93 °C (200°F) | 7. Vibration Test                              |
| 3. Static Torsion Test for Press Connections               | 8. Thermal Cycling Test                        |
| 4. Bending Test  | 9. Alternate Thermal Cycling Test              |
| 5. Vacuum Test   | 10. Dynamic Torsion Test for Press Connections |

**WARNING:** This product can expose you to chemicals including lead, which is known to the State of California to cause cancer and birth defects or other reproductive harm. For more information go to [www.P65Warnings.ca.gov](http://www.P65Warnings.ca.gov).

Visit our website for the most current information.

LEAD-FREE: Weighted average lead content ≤ 0.25%

# NIBCO® Press System Lead-Free Brass Ball Valves

**Features:** Press End Leak Detection • Side Drain/Bleeder • Two-Piece Body • PTFE Seats • Full Port • Blowout-Proof Stem

**Approvals:** IAPMO/ANSI Z1157 (IGC-157) • NSF/ANSI/CAN-61 & 372 • MSS SP-145 • Conforms to ASME B16.51†

**Size range:** 1/2" - 1"

**Pressure rating:** 250 psi non-shock cold working pressure

**Maximum pressure / temperature:** 225 psi at 250° F

Lead-Free markings: White handle and blue hang tag

**Applications:** Drinking Water • Domestic Hot & Cold Water • HVAC (condensors, chilled water, hot water heating) • Isolation and Throttling (half-open to full-open only) • Connect to Rigid Copper Tubing Manufactured per ASTM B88, Condition H (hard drawn)

Reference Press System catalog for updated Approved Tool and Jaw Compatibility Matrix list.

**Not intended for steam or gas usage.**



## PC-FP-600A-D-LF

Press x Press with Drain/Bleeder  
1/2" - 1"

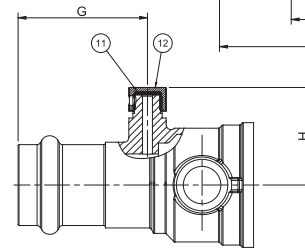
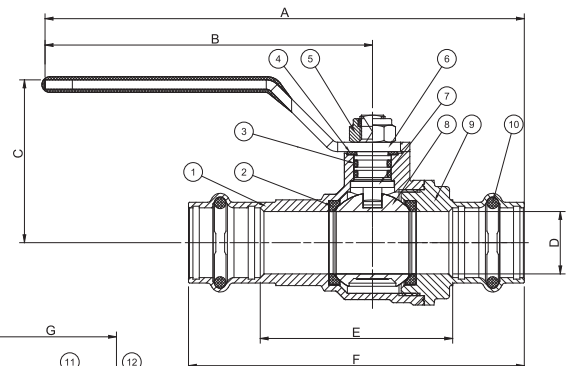

**PC-FP-600A-D-LF**  
Press x Press  
with Drain/Bleeder  
1/2" - 1"

### MATERIAL LIST

PART	SPECIFICATION
1. Body	Forged DZR Copper Alloy - C46500
2. Seat Seal	PTFE
3. O-ring	EPDM - ASTM D2000
4. Washer	PTFE
5. Lock Nut	Stainless Steel + Nylon
6. Handle	Steel, Plated
7. Stem	Brass
8. Ball	Chrome Plated Brass - C46500
9. End Cap	Forged DZR Copper Alloy - C46500
10. O-ring	EPDM - ASTM D2000
11. Washer	EPDM
12. Nut	Brass

### Options:

- Extended lever
- EPDM Seal for Press Ends
- Wing Handle
- Mini Flat



Handle Markings

### DIMENSIONS—WEIGHTS

SIZE		A		B		C		D		E		F		G		H		Weight	
In.	mm.	In.	mm.	In.	mm.	In.	mm.	In.	mm.	In.	mm.	In.	mm.	In.	mm.	In.	mm.	Lbs.	Kg.
1/2	12.7	5.26	133.70	3.62	92.00	1.34	34.00	0.59	15.00	2.15	54.70	3.73	94.70	2.09	53.00	1.44	36.50	0.5220	0.2368
3/4	19.05	6.05	153.70	4.13	105.00	2.06	52.20	0.79	20.00	2.43	61.70	4.24	107.70	2.32	59.00	1.44	36.50	0.8800	0.3991
1	25.40	6.11	155.20	4.13	105.00	2.21	56.20	0.98	25.00	2.61	66.20	4.42	112.20	2.44	62.00	1.59	40.50	1.2610	0.5719

IAPMO/ANSI Z1157: in addition to meeting ICG-157 test requirements, the IAPMO/ANSI Z1157 also requires Press ends to be fully tested to IAPMO PS-117 performance requirements which includes the following additional tests:

- |  |  |
|--|--|
| 1. Unrestrained Hydrostatic Pressure Test at 20 °C (68°F)  | 6. Hydraulic Shock (Water Hammer) Test         |
| 2. Unrestrained Hydrostatic Pressure Test at 93 °C (200°F) | 7. Vibration Test                              |
| 3. Static Torsion Test for Press Connections               | 8. Thermal Cycling Test                        |
| 4. Bending Test  | 9. Alternate Thermal Cycling Test              |
| 5. Vacuum Test   | 10. Dynamic Torsion Test for Press Connections |

†Tested to the performance criteria of ASME B16.51



**WARNING:** This product can expose you to chemicals including lead, which is known to the State of California to cause cancer and birth defects or other reproductive harm. For more information go to [www.P65Warnings.ca.gov](http://www.P65Warnings.ca.gov).

LEAD-FREE: Weighted average lead content ≤ 0.25%

Visit our website for the most current information.

# NIBCO® Press System Lead-Free Brass Ball Valves

**Features:** Press End Leak Detection • 3/4" Hose Connection w/Cap • Two-Piece Body • PTFE Seats • Full Port • Blowout-Proof Stem

**Approvals:** IAPMO/ANSI Z1157 (IGC-157) • NSF/ANSI/CAN-61 & 372 • MSS SP-145 • Conforms to ASME B16.51†

**Size range:** 1/2" - 3/4"

**Pressure rating:** 250 psi non-shock cold working pressure

**Maximum pressure / temperature:** 225 psi at 250° F

Lead-Free markings:

White handle and blue hang tag

**Applications:** Drinking Water • Domestic Hot & Cold Water • HVAC (condensors, chilled water, hot water heating) • Isolation and Throttling (half-open to full-open only) • Connect to Rigid Copper Tubing Manufactured per ASTM B88, Condition H (hard drawn)

Reference Press System catalog for updated Approved Tool and Jaw Compatibility Matrix list.

**Not intended for steam or gas usage.**

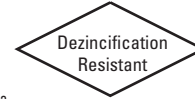

## PC-FP-600A-LF-HC

Press x Hose Cap  
1/2" - 3/4"

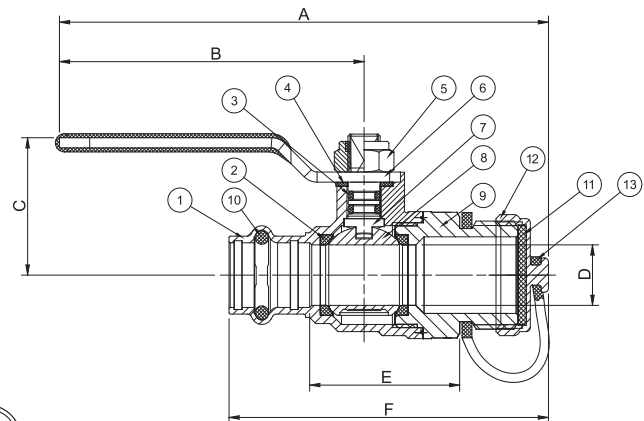

## PC-FP-600A-LF-HC

Press x Hose Cap  
1/2" - 3/4"

### MATERIAL LIST

PART	SPECIFICATION
1. Body	Forged DZR Copper Alloy - C46500
2. Seat Seal	PTFE
3. O-ring	EPDM - ASTM D2000
4. Washer	PTFE
5. Lock Nut	Stainless Steel + Nylon
6. Handle	Steel, Plated
7. Stem	Brass
8. Ball	Chrome Plated Brass - C46500
9. End Cap	Forged DZR Copper Alloy - C46500
10. O-ring	EPDM - ASTM D2000
11. Washer	EPDM
12. Nut	Brass
13. Cap Retainer	NBR

### Options:

- Extended lever
- EPDM Seal for Press Ends
- Wing Handle
- Mini Flat



Handle Markings

### DIMENSIONS—WEIGHTS

SIZE		A		B		C		D		E		F		Weight	
In.	mm.	In.	mm.	In.	mm.	In.	mm.	In.	mm.	In.	mm.	In.	mm.	Lbs.	Kg.
1/2	12.7	4.51	114.50	3.62	92.00	1.34	34.00	0.59	15.00	1.46	37.20	3.11	79.00	0.5220	0.2368
3/4	19.05	5.10	129.50	4.13	105.00	2.06	52.20	0.79	20.00	1.74	44.20	3.52	89.50	0.8090	0.3669

**IAPMO/ANSI Z1157:** in addition to meeting IGC-157 test requirements, the IAPMO/ANSI Z1157 also requires Press ends to be fully tested to IAPMO PS-117 performance requirements which includes the following additional tests:

†Tested to the performance criteria of ASME B16.51

- |  |  |
|--|--|
| 1. Unrestrained Hydrostatic Pressure Test at 20 °C (68°F)  | 6. Hydraulic Shock (Water Hammer) Test         |
| 2. Unrestrained Hydrostatic Pressure Test at 93 °C (200°F) | 7. Vibration Test                              |
| 3. Static Torsion Test for Press Connections               | 8. Thermal Cycling Test                        |
| 4. Bending Test  | 9. Alternate Thermal Cycling Test              |
| 5. Vacuum Test   | 10. Dynamic Torsion Test for Press Connections |

**WARNING:** This product can expose you to chemicals including lead, which is known to the State of California to cause cancer and birth defects or other reproductive harm. For more information go to [www.P65Warnings.ca.gov](http://www.P65Warnings.ca.gov).

Visit our website for the most current information.

LEAD-FREE: Weighted average lead content ≤ 0.25%

# NIBCO® Press System Lead-Free Brass Ball Valves

**Features:** Press End Leak Detection • PEX end F1960 Cold Expansion • Two-Piece Body • PTFE Seats • Blowout-Proof Stem • Double Stem Seal

**Approvals:** MSS SP-110/145 • IAPMO/ANSI Z1157 • NSF/ANSI 14 • NSF/ANSI/CAN 61/372 • Conforms to ASME B16.51†

**Size range:** 1/2" - 2"

**Pressure rating:** 250 psi non-shock cold working pressure

**Maximum pressure / temperature:** 225 psi at 250° F

Lead-free markings: White handle and blue hang tag

**Applications:** Drinking Water • Domestic Hot & Cold Water • HVAC (condensors, chilled water, hot water heating) • Isolation and Throttling (half-open to full-open only) • Connect to Rigid Copper Tubing Manufactured per ASTM B88, Condition H (hard drawn)

Reference Press System catalog for updated Approved Tool and Jaw Compatibility Matrix list.

**Not intended for steam or gas usage.**

## MATERIAL LIST

PART	SPECIFICATION
1. Body	Forged DZR Copper Alloy - C46500
2. Seat Seal (2)	PTFE
3. O-ring	EPDM - ASTM D2000
4. Packing	PTFE
5. Washer	Stainless Steel ASTM 321
6. Lock Nut	Stainless Steel 304
7. Handle	Steel, Plated
8. Nut	Brass
9. Stem	Brass
10. Ball	Chrome Plated Brass - C46500 (1/2"-1") Stainless Steel 316 (1 1/4"-2")
11. End Cap	Forged DZR Copper Alloy - C46500 (F1960 Cold Expansion)
12. O-ring	EPDM - ASTM D2000 (Leak Detect)
13. Metal Ring	Stainless Steel (1 1/4"-2")

### Options:

- Extended lever
- EPDM Seal for Press Ends
- Wing Handle
- Mini Flat



Handle Markings

## DIMENSIONS—WEIGHTS

SIZE	A		B		C		D		E		F		Weight	
In.	In.	mm.	In.	mm.	In.	mm.	In.	mm.	In.	mm.	In.	mm.	Lbs.	Kg.
1/2"	5.15	130.90	3.62	92.00	1.20	30.55	0.39	10.00	1.30	32.90	2.79	70.90	0.3400	0.1542
3/4"	5.48	139.20	3.62	92.00	1.34	34.00	0.60	15.30	1.48	37.70	3.33	84.70	0.5090	0.2308
1"	6.37	161.70	4.13	105.00	2.06	52.20	0.79	20.00	1.74	44.20	3.83	97.20	0.8620	0.3909
1 1/4"	7.09	180.00	4.37	111.00	2.58	65.5	0.98	25.00	2.19	55.50	4.75	120.70	1.5400	0.6900
1 1/2"	8.31	211.00	5.04	128.00	2.70	68.5	1.09	27.80	2.63	66.85	5.72	145.40	2.3300	1.0600
2"	10.19	258.80	6.22	158.00	3.16	80.2	1.57	40.00	3.12	79.20	6.92	175.70	3.6600	1.6600

**IAPMO/ANSI Z1157:** In addition to meeting ICG-157 test requirements, the IAPMO/ANSI Z1157 also requires Press ends to be fully tested to IAPMO PS-117 performance requirements which includes the following additional tests:

- |  |  |                         |  |
|--|--|-------------------------|--|
| 1. Unrestrained Hydrostatic Pressure Test at 20 °C (68°F)  | 4. Bending Test                        | 7. Vibration Test       | 9. Alternate Thermal Cycling Test              |
| 2. Unrestrained Hydrostatic Pressure Test at 93 °C (200°F) | 5. Vacuum Test                         | 8. Thermal Cycling Test | 10. Dynamic Torsion Test for Press Connections |
| 3. Static Torsion Test for Press Connections               | 6. Hydraulic Shock (Water Hammer) Test |                         |  |



**WARNING:** This product can expose you to chemicals including lead, which is known to the State of California to cause cancer and birth defects or other reproductive harm. For more information go to [www.P65Warnings.ca.gov](http://www.P65Warnings.ca.gov).

LEAD-FREE: Weighted average lead content ≤ 0.25%



## PCPXA-FP-600A-LF

Press x PEX (F1960 - Cold Expansion)  
1/2" - 2"  
Patent US 10,240,698; Sizes 1-1/4" - 2"

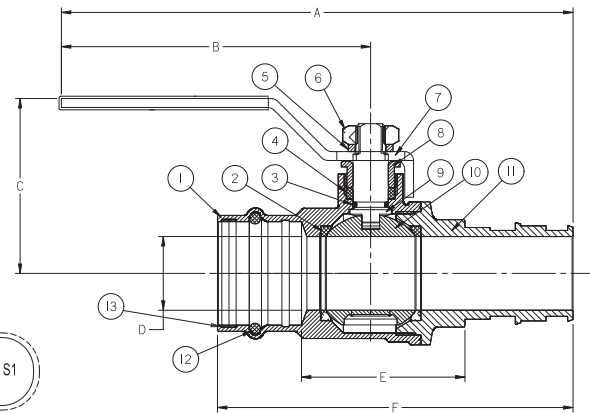

## PCPXA-FP-600A-LF

Press x PEX (F1960 - Cold Expansion)  
1/2" - 2" ††

†† Tested to the performance criteria of ASME B16.51

Visit our website for the most current information.

# NIBCO® Press System Lead-Free Brass Ball Valves

**Features:** Press End Leak Detection • PEX End F1807 Crimp • Two-Piece Body • PTFE Seats • Blowout-Proof Stem • Double Stem Seal

**Approvals:** MSS SP-110/145 • IAPMO/ANSI Z1157 • NSF/ANSI 14 • NSF/ANSI/CAN 61/372 • Conforms to ASME B16.51†

**Size range:** 1/2" - 2"

**Pressure rating:** 250 psi non-shock cold working pressure

**Maximum pressure / temperature:** 225 psi at 250° F

Lead-free markings: White handle and blue hang tag

**Applications:** Drinking Water • Domestic Hot & Cold Water • HVAC (condensors, chilled water, hot water heating) • Isolation and Throttling (half-open to full-open only) • Connect to Rigid Copper Tubing Manufactured per ASTM B88, Condition H (hard drawn)

Reference Press System catalog for updated Approved Tool and Jaw Compatibility Matrix list.

**Not intended for steam or gas usage.**

## MATERIAL LIST

PART	SPECIFICATION
1. Body	Forged DZR Copper Alloy - C46500
2. Seat Seal (2)	PTFE
3. O-ring	EPDM - ASTM D2000
4. Packing	PTFE
5. Washer	Stainless Steel ASTM 321
6. Lock Nut	Stainless Steel 304
7. Handle	Steel, Plated
8. Nut	Brass
9. Stem	Brass
10. Ball	Chrome Plated Brass - C46500 (1/2"-1") Stainless Steel 316 (1 1/4"-2")
11. End Cap	Forged DZR Copper Alloy - C46500 (F1807 Crimp)
12. O-ring	EPDM - ASTM D2000 (Leak Detect)
13. Metal Ring	Stainless Steel (1 1/4"-2")

### Options:

- Extended lever
- EPDM Seal for Press Ends
- Wing Handle
- Mini Flat



Handle Markings

## DIMENSIONS—WEIGHTS

SIZE	A		B		C		D		E		F		Weight	
	In.	mm.	In.	mm.	In.	mm.	In.	mm.	In.	mm.	In.	mm.	Lbs.	Kg.
1/2"	5.11	129.90	3.62	92.00	1.20	30.55	0.39	10.00	1.30	32.90	2.75	69.90	0.3280	0.1487
3/4"	5.19	131.70	3.62	92.00	1.34	34.00	0.60	15.30	1.50	38.20	3.04	77.20	0.4810	0.2181
1"	5.97	151.70	4.13	105.00	2.06	52.20	0.80	20.30	1.72	43.70	3.43	87.20	0.7850	0.3560
1 1/4"	6.61	168.00	4.37	111.00	2.58	65.50	0.87	22.20	2.21	56.20	4.28	108.70	1.4400	0.6500
1 1/2"	7.76	197.00	5.04	128.00	2.70	68.50	1.03	26.10	2.63	66.75	5.17	131.40	2.1900	0.9900
2"	9.51	241.50	6.22	158.00	3.16	80.20	1.37	34.70	3.09	78.60	6.25	158.70	3.3600	1.5200

**IAPMO/ANSI Z1157:** in addition to meeting ICG-157 test requirements, the IAPMO/ANSI Z1157 also requires Press ends to be fully tested to IAPMO PS-117 performance requirements which includes the following additional tests:

†Tested to the performance criteria of ASME B16.51

- |  |  |                         |  |
|--|--|-------------------------|--|
| 1. Unrestrained Hydrostatic Pressure Test at 20 °C (68°F)  | 4. Bending Test                        | 7. Vibration Test       | 9. Alternate Thermal Cycling Test              |
| 2. Unrestrained Hydrostatic Pressure Test at 93 °C (200°F) | 5. Vacuum Test                         | 8. Thermal Cycling Test | 10. Dynamic Torsion Test for Press Connections |
| 3. Static Torsion Test for Press Connections               | 6. Hydraulic Shock (Water Hammer) Test |                         |  |

**WARNING:** This product can expose you to chemicals including lead, which is known to the State of California to cause cancer and birth defects or other reproductive harm. For more information go to [www.P65Warnings.ca.gov](http://www.P65Warnings.ca.gov).

Visit our website for the most current information.

LEAD-FREE: Weighted average lead content ≤ 0.25%



### PCPX-FP-600A-LF

Press x PEX (F1807 - Crimp)  
1/2" - 2"  
Patent US 10,240,698; Sizes 1-1/4" - 2"

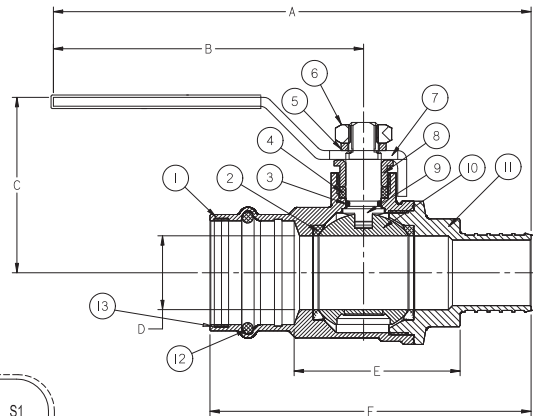

### PCPX-FP-600A-LF

Press x PEX (F1807 - Crimp)  
1/2" - 2" ††

# NIBCO® Press System Lead-Free Brass Ball Valves

**Features:** Press End Leak Detection • FIP Union • Two-Piece Body • PTFE Seats • Full Port • Blowout-Proof Stem

**Approvals:** IAPMO/ANSI Z1157 (IGC-157) • NSF/ANSI/CAN 61 & 372 • MSS SP-145 • Conforms to ASME B16.51†

**Size range:** 1/2" - 1"

**Pressure rating:** 250 psi non-shock cold working pressure

**Maximum pressure / temperature:** 225 psi at 250° F

Lead-Free markings: White handle and blue hang tag

**Applications:** Drinking Water • Domestic Hot & Cold Water • HVAC (condensors, chilled water, hot water heating) • Isolation and Throttling (half-open to full-open only) • Connect to Rigid Copper Tubing Manufactured per ASTM B88, Condition H (hard drawn)

Reference Press System catalog for updated Approved Tool and Jaw Compatibility Matrix list.

**Not intended for steam or gas usage.**



**PCFU-FP-600A-LF**

Press x FIP Union  
1/2" - 1"

## MATERIAL LIST

PART	SPECIFICATION
1. Body	Forged DZR Copper Alloy - C46500
2. Seat Seal	PTFE
3. O-ring	EPDM - ASTM D2000
4. Washer	PTFE
5. Lock Nut	Stainless Steel + Nylon
6. Handle	Steel, Plated
7. Stem	Brass
8. Ball	Chrome Plated Brass - C46500
9. End Cap	Forged DZR Copper Alloy - C46500
10. O-ring	EPDM - ASTM D2000
11. Fitting	Forged DZR Copper Alloy - C46500
12. Washer	EPDM
13. Nut	Brass

### Options:

- Extended lever
- EPDM Seal for Press Ends
- Wing Handle
- Mini Flat



Handle Markings

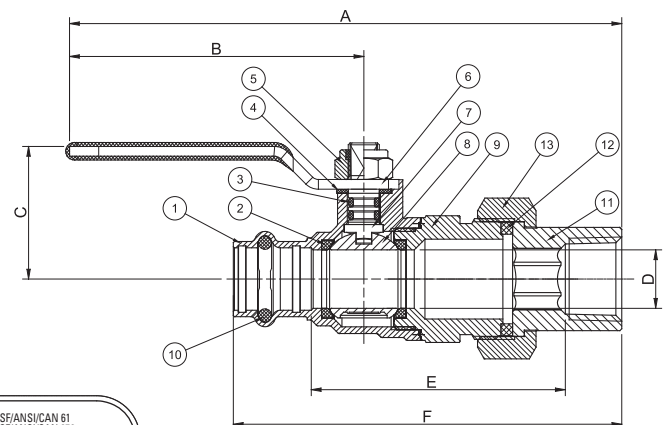

**PCFU-FP-600A-LF**

Press x FIP Union  
1/2" - 1"

## DIMENSIONS—WEIGHTS

SIZE		A		B		C		D		E		F		Weight	
In.	mm.	In.	mm.	In.	mm.	In.	mm.	In.	mm.	In.	mm.	In.	mm.	Lbs.	Kg.
1/2	12.7	6.23	158.20	3.62	92.00	1.34	34.00	0.59	15.00	2.57	65.20	3.93	99.70	0.7720	0.3501
3/4	19.05	6.92	175.70	4.13	105.00	2.06	52.20	0.79	20.00	2.84	72.20	4.38	111.20	1.2040	0.5461
1	25.40	7.17	182.20	4.13	105.00	2.21	56.20	0.98	25.00	3.11	79.00	4.77	121.20	1.7750	0.8051

**IAPMO/ANSI Z1157:** in addition to meeting IGC-157 test requirements, the IAPMO/ANSI Z1157 also requires Press ends to be fully tested to IAPMO PS-117 performance requirements which includes the following additional tests:

- |  |  |
|--|--|
| 1. Unrestrained Hydrostatic Pressure Test at 20 °C (68°F)  | 6. Hydraulic Shock (Water Hammer) Test         |
| 2. Unrestrained Hydrostatic Pressure Test at 93 °C (200°F) | 7. Vibration Test                              |
| 3. Static Torsion Test for Press Connections               | 8. Thermal Cycling Test                        |
| 4. Bending Test  | 9. Alternate Thermal Cycling Test              |
| 5. Vacuum Test   | 10. Dynamic Torsion Test for Press Connections |

†Tested to the performance criteria of ASME B16.51

**WARNING:** This product can expose you to chemicals including lead, which is known to the State of California to cause cancer and birth defects or other reproductive harm. For more information go to [www.P65Warnings.ca.gov](http://www.P65Warnings.ca.gov).

LEAD-FREE: Weighted average lead content ≤ 0.25%

Visit our website for the most current information.

# NIBCO® Press System Lead-Free Brass Ball Valves

**Features:** Press Ends Leak Detection • Press x MIP Union • Two-Piece Body • PTFE Seats • Full Port • Blowout-Proof Stem

**Approvals:** MSS SP-110/145 • IAPMO/ANSI Z1157 • NSF/ANSI/CAN 61/372 • Conforms to ASME B16.51†

**Size range:** 1/2" - 1"

**Pressure rating:** 250 psi non-shock cold working pressure

**Maximum pressure / temperature:** 225 psi at 250° F

Lead-free markings: White handle and blue hang tag

**Applications:** Drinking Water • Domestic Hot & Cold Water • HVAC (condensors, chilled water, hot water heating) • Isolation and Throttling (half-open to full-open only) • Connect to Rigid Copper Tubing Manufactured per ASTM B88, Condition H (hard drawn)

Reference Press System catalog for updated Approved Tool and Jaw Compatibility Matrix list.

**Not intended for steam or gas usage.**

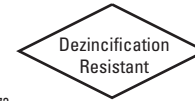

**PCMU-FP-600A-LF**

Press x MIP Union  
1/2" - 1"

## MATERIAL LIST

PART	SPECIFICATION
1. Body	Forged DZR Copper Alloy - C46500
2. Seat Seal (2)	PTFE
3. O-ring	EPDM - ASTM D2000
4. Packing	PTFE
5. Washer	Stainless Steel ASTM 321
6. Lock Nut	Stainless Steel 304
7. Handle	Steel, Plated
8. Nut	Brass
9. Stem	Brass
10. Ball	Chrome Plated Brass - C46500
11. End Cap	Forged DZR Copper Alloy - C46500
12. Union Nut	Brass
13. Washer	EPDM
14. MIP Fitting	Forged DZR Copper Alloy - C46500
15. O-ring	EPDM - ASTM D2000 (Leak Detect)

### Options:

- Extended lever
- EPDM Seal for Press Ends
- Wing Handle
- Mini Flat



Handle Markings

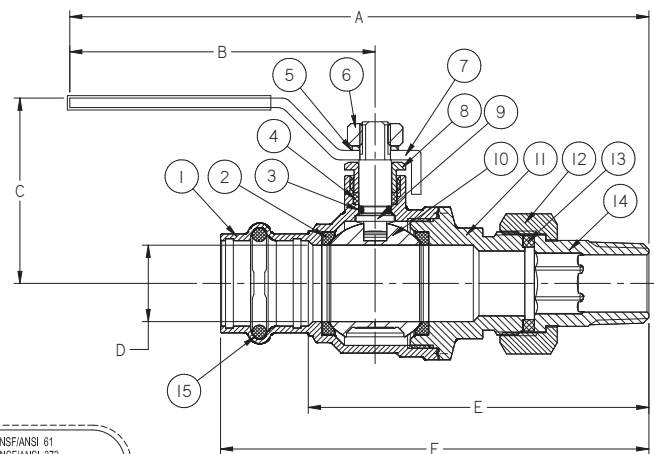

**PCMU-FP-600A-LF**  
Press x MIP Union  
1/2" - 1"

## DIMENSIONS—WEIGHTS

SIZE		A		B		C		D		E		F		Weight	
In.	mm.	In.	mm.	In.	mm.	In.	mm.	In.	mm.	In.	mm.	In.	mm.	Lbs.	Kg.
1/2"	12.70	6.31	160.20	3.62	92.00	1.34	34.00	0.59	15.00	2.60	66.00	4.00	101.70	0.6720	0.3048
3/4"	19.05	6.92	175.70	4.13	105.00	2.06	52.20	0.79	20.00	2.81	71.50	4.38	111.20	1.0580	0.4799
1"	25.40	7.13	181.20	4.13	105.00	2.21	56.20	0.98	25.00	3.05	77.50	4.73	120.20	1.5790	0.7162
3/4" x 1/2" MIP		6.80	172.70	3.98	101.00	2.11	53.50	0.59	15.00	3.51	89.20	4.42	112.20	0.9800	0.4500

**IAPMO/ANSI Z1157:** in addition to meeting ICG-157 test requirements, the IAPMO/ANSI Z1157 also requires Press ends to be fully tested to IAPMO PS-117 performance requirements which includes the following additional tests:

- |  |  |                         |  |
|--|--|-------------------------|--|
| 1. Unrestrained Hydrostatic Pressure Test at 20 °C (68°F)  | 4. Bending Test                        | 7. Vibration Test       | 9. Alternate Thermal Cycling Test              |
| 2. Unrestrained Hydrostatic Pressure Test at 93 °C (200°F) | 5. Vacuum Test                         | 8. Thermal Cycling Test | 10. Dynamic Torsion Test for Press Connections |
| 3. Static Torsion Test for Press Connections               | 6. Hydraulic Shock (Water Hammer) Test |                         |  |

†Tested to the performance criteria of ASME B16.51

**WARNING:** This product can expose you to chemicals including lead, which is known to the State of California to cause cancer and birth defects or other reproductive harm. For more information go to [www.P65Warnings.ca.gov](http://www.P65Warnings.ca.gov).

Visit our website for the most current information.

LEAD-FREE: Weighted average lead content ≤ 0.25%

# NIBCO<sup>®</sup> Press System Lead-Free Brass Ball Valves

**Features:** Press End Leak Detection • Solder Union • Two-Piece Body • PTFE Seats • Full Port • Blowout-Proof Stem

**Approvals:** IAPMO/ANSI Z1157 (IGC-157) • NSF/ANSI/CAN 61 & 372 • MSS SP-145 • Conforms to ASME B16.51†

**Size range:** 1/2" - 1"

**Pressure rating:** 250 psi non-shock cold working pressure

**Maximum pressure / temperature:** 225 psi at 250° F

Lead-Free markings: White handle and blue hang tag

**Applications:** Drinking Water • Domestic Hot & Cold Water • HVAC (condensors, chilled water, hot water heating) • Isolation and Throttling (half-open to full-open only) • Connect to Rigid Copper Tubing Manufactured per ASTM B88, Condition H (hard drawn)

Reference Press System catalog for updated Approved Tool and Jaw Compatibility Matrix list.

**Not intended for steam or gas usage.**



**PCSU-FP-600A-LF**

Press x Solder Union  
1/2" - 1"

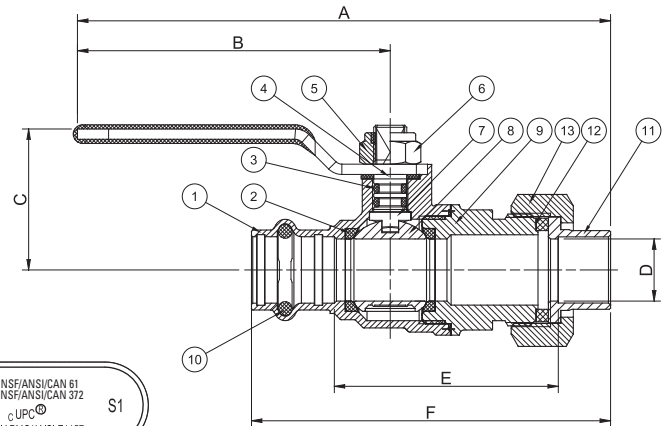

**PCSU-FP-600A-LF**

Press x Solder Union  
1/2" - 1"

## MATERIAL LIST

PART	SPECIFICATION
1. Body	Forged DZR Copper Alloy - C46500
2. Seat Seal	PTFE
3. O-ring	EPDM - ASTM D2000
4. Washer	PTFE
5. Lock Nut	Stainless Steel + Nylon
6. Handle	Steel, Plated
7. Stem	Brass
8. Ball	Chrome Plated Brass - C46500
9. End Cap	Forged DZR Copper Alloy - C46500
10. O-ring	EPDM - ASTM D2000
11. Fitting	Forged DZR Copper Alloy - C46500
12. Washer	EPDM
13. Nut	Brass

### Options:

- Extended lever
- EPDM Seal for Press Ends
- Wing Handle
- Mini Flat



Handle Markings

## DIMENSIONS—WEIGHTS

SIZE		A		B		C		D		E		F		Weight	
In.	mm.	In.	mm.	In.	mm.	In.	mm.	In.	mm.	In.	mm.	In.	mm.	Lbs.	Kg.
1/2	12.7	5.72	145.20	3.62	92.00	1.34	34.00	0.59	15.00	2.13	54.10	3.41	86.70	0.6130	0.2780
3/4	19.05	6.64	168.70	4.13	105.00	2.06	52.20	0.79	20.00	2.44	62.10	4.10	104.20	1.0010	0.4540
1	25.40	6.90	175.20	4.13	105.00	2.21	56.20	0.98	25.00	2.68	68.10	4.50	114.20	1.4880	0.6749

IAPMO/ANSI Z1157: in addition to meeting IGC-157 test requirements, the IAPMO/ANSI Z1157 also requires Press ends to be fully tested to IAPMO PS-117 performance requirements which includes the following additional tests:

- |  |  |
|--|--|
| 1. Unrestrained Hydrostatic Pressure Test at 20 °C (68°F)  | 6. Hydraulic Shock (Water Hammer) Test         |
| 2. Unrestrained Hydrostatic Pressure Test at 93 °C (200°F) | 7. Vibration Test                              |
| 3. Static Torsion Test for Press Connections               | 8. Thermal Cycling Test                        |
| 4. Bending Test  | 9. Alternate Thermal Cycling Test              |
| 5. Vacuum Test   | 10. Dynamic Torsion Test for Press Connections |

†Tested to the performance criteria of ASME B16.51



**WARNING:** This product can expose you to chemicals including lead, which is known to the State of California to cause cancer and birth defects or other reproductive harm. For more information go to [www.P65Warnings.ca.gov](http://www.P65Warnings.ca.gov).

LEAD-FREE: Weighted average lead content ≤ 0.25%

Visit our website for the most current information.

# NIBCO® Press System Lead-Free Brass Ball Valves

**Features:** Press End Leak Detection • Press x Press Union • Two-Piece Body • PTFE Seats • Full Port • Blowout-Proof Stem

**Approvals:** MSS SP-110/145 • IAPMO/ANSI Z1157 • NSF/ANSI/CAN 61/372 • Conforms to ASME B16.51†

**Size range:** 1/2" - 1"

**Pressure rating:** 250 psi non-shock cold working pressure

**Maximum pressure / temperature:** 225 psi at 250° F

Lead-free markings: White handle and blue hang tag

**Applications:** Drinking Water • Domestic Hot & Cold Water • HVAC (condensors, chilled water, hot water heating) • Isolation and Throttling (half-open to full-open only) • Connect to Rigid Copper Tubing Manufactured per ASTM B88, Condition H (hard drawn)

Reference Press System catalog for updated Approved Tool and Jaw Compatibility Matrix list.

**Not intended for steam or gas usage.**

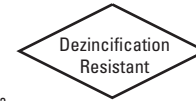

## PCU-FP-600A-LF

Press x Press Union

1/2" - 1"

### MATERIAL LIST

PART	SPECIFICATION
1. Body	Forged DZR Copper Alloy - C46500
2. Seat Seal (2)	PTFE
3. O-ring	EPDM - ASTM D2000
4. Packing	PTFE
5. Washer	Stainless Steel ASTM 321
6. Lock Nut	Stainless Steel 304
7. Handle	Steel, Plated
8. Nut	Brass
9. Stem	Brass
10. Ball	Chrome Plated Brass - C46500
11. End Cap	Forged DZR Copper Alloy - C46500
12. Union Nut	Brass
13. Washer	EPDM
14. Press Fitting	Forged DZR Copper Alloy - C46500
15. O-ring (2)	EPDM - ASTM D2000 (Leak Detect)

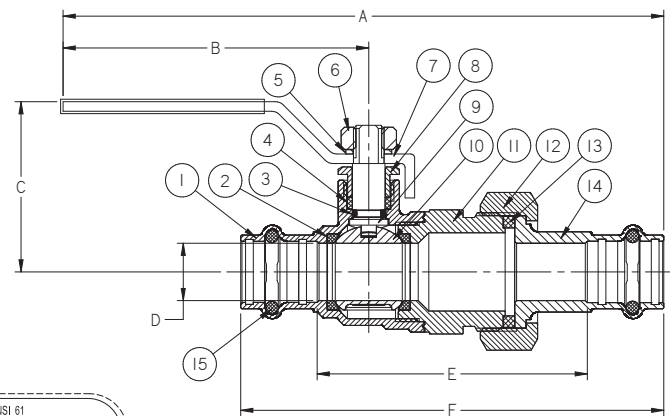

## PCU-FP-600A-LF

Press x Press Union

1/2" - 1"

### Options:

- Extended lever
- EPDM Seal for Press Ends
- Wing Handle
- Mini Flat



Handle Markings

### DIMENSIONS—WEIGHTS

SIZE		A		B		C		D		E		F		Weight	
In.	mm.	In.	mm.	In.	mm.	In.	mm.	In.	mm.	In.	mm.	In.	mm.	Lbs.	Kg.
1/2"	12.70	6.82	173.20	3.78	96.00	1.83	46.50	0.59	15.00	2.78	70.70	4.36	110.70	0.77	0.35
3/4"	19.05	7.23	183.70	3.98	101.00	2.11	53.50	0.79	20.00	3.04	77.20	4.85	123.20	1.19	0.54
1"	25.40	7.69	195.20	4.37	111.00	2.58	65.50	0.98	25.00	3.24	82.20	5.05	128.20	1.77	0.80

**IAPMO/ANSI Z1157:** in addition to meeting ICG-157 test requirements, the IAPMO/ANSI Z1157 also requires Press ends to be fully tested to IAPMO PS-117 performance requirements which includes the following additional tests:

- |  |  |                         |  |
|--|--|-------------------------|--|
| 1. Unrestrained Hydrostatic Pressure Test at 20 °C (68°F)  | 4. Bending Test                        | 7. Vibration Test       | 9. Alternate Thermal Cycling Test              |
| 2. Unrestrained Hydrostatic Pressure Test at 93 °C (200°F) | 5. Vacuum Test                         | 8. Thermal Cycling Test | 10. Dynamic Torsion Test for Press Connections |
| 3. Static Torsion Test for Press Connections               | 6. Hydraulic Shock (Water Hammer) Test |                         |  |

†Tested to the performance criteria of ASME B16.51

**WARNING:** This product can expose you to chemicals including lead, which is known to the State of California to cause cancer and birth defects or other reproductive harm. For more information go to [www.P65Warnings.ca.gov](http://www.P65Warnings.ca.gov).

Visit our website for the most current information.

LEAD-FREE: Weighted average lead content ≤ 0.25%

# NIBCO® Press System Lead-Free Brass Ball Valves

**Features:** Press Slip • Press Ends Leak Detection • Double Stem Seal • Two-Piece Body • PTFE Seats • Full Port • Blowout-Proof Stem

**Approvals:** MSS SP-110/145 • IAPMO/ANSI Z1157 • NSF/ANSI/CAN 61/372 • Conforms to ASME B16.51†

**Size range:** 1/2" - 1"

**Pressure rating:** 250 psi non-shock cold working pressure

**Maximum pressure / temperature:** 225 psi at 250° F

Lead-free markings: White handle and blue hang tag

**Applications:** Drinking Water • Domestic Hot & Cold Water • HVAC (condensers, chilled water, hot water heating) • Isolation and Throttling (half-open to full-open only) • Connect to Rigid Copper Tubing Manufactured per ASTM B88, Condition H (hard drawn)

Reference Press System catalog for updated Approved Tool and Jaw Compatibility Matrix list.

**Not intended for steam or gas usage.**



**PC-FP-600A-S-LF**

Press x Press Slip  
1/2" - 1"

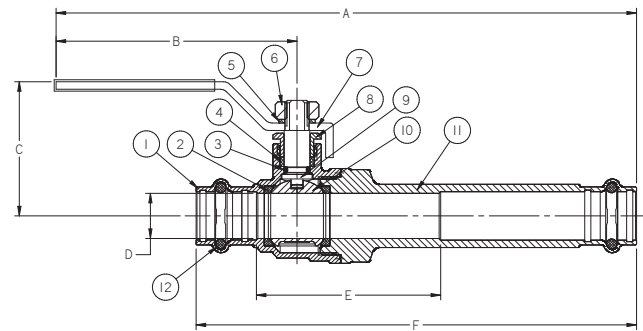

**PC-FP-600A-S-LF**

Press x Press Slip  
1/2" - 1"

## MATERIAL LIST

PART	SPECIFICATION
1. Body	Forged DZR Copper Alloy - C46500
2. Seat Seal (2)	PTFE
3. O-ring	EPDM - ASTM D2000
4. Packing	PTFE
5. Washer	Stainless Steel ASTM 321
6. Lock Nut	Stainless Steel 304
7. Handle	Steel, Plated
8. Nut	Brass
9. Stem	Brass
10. Ball	Chrome Plated Brass - C46500
11. End Cap / Slip Side	Forged DZR Copper Alloy - C46500
12. O-ring (2)	EPDM - ASTM D2000

### Options:

- Extended lever
- EPDM Seal for Press Ends
- Wing Handle
- Mini Flat



Handle Markings

## DIMENSIONS—WEIGHTS—QUANTITIES

SIZE	A		B		C		D		E		F		Weight	
	In.	mm.	In.	mm.	In.	mm.	In.	mm.	In.	mm.	In.	mm.	Lbs.	Kg.
1/2"	8.23	209	3.78	96	1.83	46.5	0.63	16.03	2.41	61.2	5.76	146.2	0.7	0.32
3/4"	9.12	231.7	3.98	101	2.11	53.5	0.88	22.43	2.88	73.2	6.74	171.2	1.19	0.54
1"	10.13	257.2	4.37	111	2.58	65.5	1.14	28.96	3.43	87.2	7.49	190.2	1.82	0.83

IAPMO/ANSI Z1157: in addition to meeting ICG-157 test requirements, the IAPMO/ANSI Z1157 also requires Press ends to be fully tested to IAPMO PS-117 performance requirements which includes the following additional tests:

1. Unrestrained Hydrostatic Pressure Test at 20 °C (68°F)
2. Unrestrained Hydrostatic Pressure Test at 93 °C (200°F)
3. Static Torsion Test for Press Connections
4. Bending Test
5. Vacuum Test
6. Hydraulic Shock (Water Hammer) Test
7. Vibration Test
8. Thermal Cycling Test
9. Alternate Thermal Cycling Test
10. Dynamic Torsion Test for Press Connections

†Tested to the performance criteria of ASME B16.51



**WARNING:** This product can expose you to chemicals including lead, which is known to the State of California to cause cancer and birth defects or other reproductive harm. For more information go to [www.P65Warnings.ca.gov](http://www.P65Warnings.ca.gov).

LEAD-FREE: Weighted average lead content ≤ 0.25%

Visit our website for the most current information.

# NIBCO® Press System Lead-Free Brass Ball & Check Valves

**Features:** All-in-one Ball and Inline Check Valve • Press Ends Leak Detection • Double Stem Seal • Two-Piece Body • PTFE Seats • Full Port • Blowout-Proof Stem

**Approvals:** MSS SP-110/145 • IAPMO/ANSI Z1157 • NSF/ANSI/CAN 61/372 • Conforms to ASME B16.51†

**Size range:** 1/2" - 1½"

**Pressure rating:** 250 psi non-shock cold working pressure

**Maximum pressure / temperature:** 150 psi at 250° F

Lead-free markings: White handle and blue hang tag

**Applications:** Drinking Water • Domestic Hot & Cold Water • HVAC (condensors, chilled water, hot water heating) • Isolation and Throttling (half-open to full-open only) • Connect to Rigid Copper Tubing Manufactured per ASTM B88, Condition H (hard drawn)

Reference Press System catalog for updated Approved Tool and Jaw Compatibility Matrix list.

**Not intended for steam or gas usage.**

## MATERIAL LIST

PART	SPECIFICATION
1. Body	Forged DZR Copper Alloy - C46500
2. Seat Seal (2)	PTFE
3. O-ring	EPDM - ASTM D2000
4. Packing	PTFE
5. Washer	Stainless Steel ASTM 321
6. Lock Nut	Stainless Steel 304
7. Handle	Steel, Plated
8. Nut	Brass
9. Stem	Brass
10. Ball	Chrome Plated Brass - C46500 (½"-1") Stainless Steel 316 (1¼"-1½")
11. End Cap	Forged DZR Copper Alloy - C46500
12. Check Valve	OV25-HT Cartridge
13. O-ring (2)	EPDM - ASTM D2000 (Leak Detect)
14. Metal Ring (2)	Stainless Steel (1¼"-1½")

### Options:

- Extended lever
- EPDM Seal for Press Ends
- Wing Handle
- Mini Flat



## DIMENSIONS—WEIGHTS

SIZE	A		B		C		D		E		F		Weight	
In.	In.	mm.	In.	mm.	In.	mm.	In.	mm.	In.	mm.	In.	mm.	Lbs.	Kg.
1/2"	5.87	149.00	3.78	96.00	1.83	46.50	0.631	16.03	1.82	46.20	3.39	86.20	0.50	0.23
3/4"	6.58	167.20	3.98	101.00	2.11	53.50	0.883	22.43	2.39	60.70	4.20	106.70	0.88	0.40
1"	7.36	187.00	4.37	111.00	2.58	65.50	1.140	28.96	2.90	73.70	4.71	119.70	1.42	0.65
1¼"	8.82	224.00	5.04	128.00	2.70	68.50	1.386	35.20	3.62	91.90	5.86	148.90	2.16	0.98
1½"	10.69	271.50	6.22	158.00	3.16	80.20	1.636	41.56	4.22	107.20	7.00	177.70	3.12	1.42

**IAPMO/ANSI Z1157:** in addition to meeting ICG-157 test requirements, the IAPMO/ANSI Z1157 also requires Press ends to be fully tested to IAPMO Z1117 performance requirements which includes the following additional tests:

†Tested to the performance criteria of ASME B16.51  
‡ Patent US 10,240,698

- |  |  |                         |  |
|--|--|-------------------------|--|
| 1. Unrestrained Hydrostatic Pressure Test at 20 °C (68°F)  | 4. Bending Test                        | 7. Vibration Test       | 9. Alternate Thermal Cycling Test              |
| 2. Unrestrained Hydrostatic Pressure Test at 93 °C (200°F) | 5. Vacuum Test                         | 8. Thermal Cycling Test | 10. Dynamic Torsion Test for Press Connections |
| 3. Static Torsion Test for Press Connections               | 6. Hydraulic Shock (Water Hammer) Test |                         |  |

**WARNING:** This product can expose you to chemicals including lead, which is known to the State of California to cause cancer and birth defects or other reproductive harm. For more information go to [www.P65Warnings.ca.gov](http://www.P65Warnings.ca.gov).

Visit our website for the most current information.

LEAD-FREE: Weighted average lead content ≤ 0.25%



**PC-FP-485-LF**

Press x Press

1/2" - 1½"

(Patent US 10,240,698; sizes 1¼"-1½")

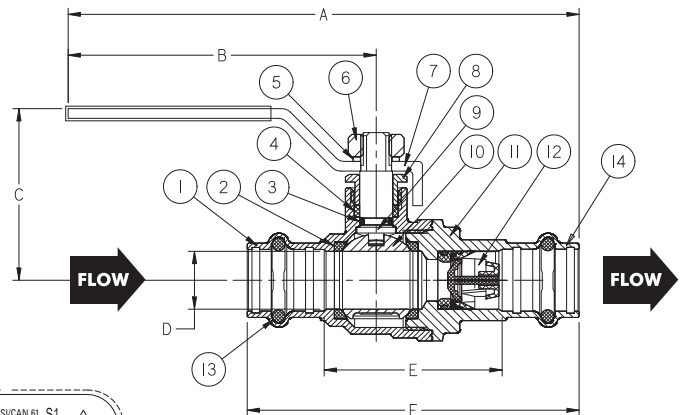

**PC-FP-485-LF**

Press x Press

1/2" - 1½"

# NIBCO® Press System Bronze Gate Valves

Screw-In Bonnet • Rising Stem • Solid Wedge

**200 psi/13.8 bar non-shock cold working pressure**

**250°F maximum operating temperature**

CONFORMS TO MSS SP-80/SP-139

## MATERIAL LIST

PART	SPECIFICATION
1. Handwheel Nut	300 Series Stainless Steel
2. Identification Plate	Aluminum
3. Handwheel	Malleable Iron ASTM A 47
4. Stem	Silicon Bronze ASTM B 371 Alloy C69430 or ASTM B 99 Alloy C65100
5. Pack Nut	Brass ASTM B 16 Alloy C36000
6. Pack Gland	Brass ASTM B 16 Alloy C36000
7. Packing	Aramid Fibers with Graphite
8. Bonnet	Bronze ASTM B 62 Alloy C83600
9. Body Assembly	Bronze ASTM B 62 Alloy C83600
10. Wedge	Bronze ASTM B 62 Alloy C83600
11. Female Adapter (2)	Wrot Copper ASTM B75 Alloy C12200
12. O-Ring (2)	EPDM



**PF-111**

Press x Press  
Female End

## DIMENSIONS—WEIGHTS

Size	Dimensions						Weight		
	A		B		C		Lbs.	Kg.	
In.	mm.	In.	mm.	In.	mm.	In.	mm.	Lbs.	Kg.
½†	15	1.97	50	4.81	122	.50	13	.84	.38
¾	20	2.62	67	5.81	148	.75	19	1.30	.59
1	25	3.07	78	7.09	180	1.00	25	2.09	.95
1¼	32	3.36	85	8.13	206	1.25	32	2.95	1.34
1½	40	3.70	94	9.81	249	1.50	38	4.16	1.89
2	50	4.28	109	11.56	294	2.00	51	6.79	3.09

† No packing gland, packing only in this size.

NIBCO Press end gate valves are designed to MSS SP-80 with the exception of Press connections designed to MSS SP-139. Valves with Press ends are rated to align with NIBCO Press System max pressure.

**WARNING:** This product can expose you to chemicals including lead, which is known to the State of California to cause cancer and birth defects or other reproductive harm. For more information go to [www.P65Warnings.ca.gov](http://www.P65Warnings.ca.gov).

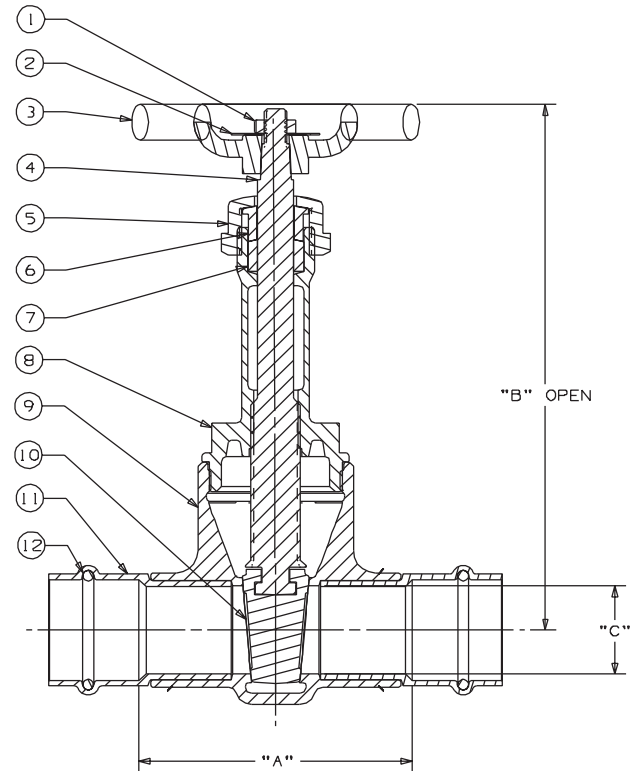

**PF-111**  
P x P

Visit our website for the most current information.

# NIBCO® Press System Lead-Free Bronze Gate Valves

Silicon Performance Bronze® Alloy • Screw-In Bonnet • Rising Stem •  
Conforms to MSS SP-139 • Solid Wedge • Press Ends Leak Detection

**Pressure rating: 250<sup>†</sup> psi non-shock cold working pressure**  
**Maximum pressure / temperature: 150 psi at 250° F**

Lead-Free markings:  
Double oval in body casting, white handle and blue hang tag

NSF/ANSI/CAN 61-8 Commercial Hot 180°F • NSF/ANSI/  
CAN 372



NSF/ANSI/CAN 372



## MATERIAL LIST

PART	SPECIFICATION
1. Handwheel Nut	300 Series Stainless Steel
2. Handwheel	Malleable Iron ASTM A47, 35018
3. Stem	Silicon Bronze ASTM B371 Alloy C69430
4. Packing Gland	ASTM B16 C36000
5. Stem Packing	Aramid Fibers with Graphite
6. Packing Nut	ASTM B16 C36000
7. Bonnet	Silicon Bronze ASTM B584 Alloy C87850
8. Body	Silicon Bronze ASTM B584 Alloy C87850
9. Wedge	Silicon Bronze ASTM B584 Alloy C87850
10. Identification Plate	Aluminum
11. Boss seal o-ring (2)	EPDM
12. Press End Adapter (2)	Wrot Copper ASTM B75 Alloy C12200
13. Crimp Evident Seal (2)	EPDM - Leak Detection

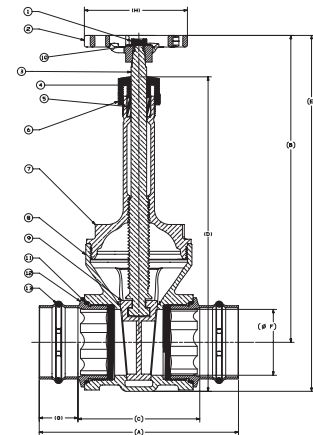

**PC-111-LF**  
Press x Press  
Female End

## DIMENSIONS—WEIGHTS—QUANTITIES

SIZE	A		B		C		D		E		F		G		H		Weight		Master Ctn Qty.	
	In.	mm.	In.	mm.	In.	mm.	In.	mm.	In.	mm.	In.	mm.	In.	mm.	In.	mm.	Lbs.	Kg.		
1/2 <sup>‡</sup>	15	3.68	93.47	4.85	123	2.28	57.9	3.92	100	4.82	122	0.5	13	0.7	17.78	2.44	62	0.96	0.43	50
3/4	20	4.28	108.7	5.89	150	2.36	60	4.93	125	5.74	146	0.75	19	0.96	24	2.44	62	1.38	0.62	25
1	25	4.62	117.3	7.21	183	2.85	72.4	5.95	151	6.93	176	1.00	25	0.88	22.35	3.19	81	2.18	0.99	20
1-1/4	32	5.1	129.5	8.20	208	3.08	78.23	6.69	170	7.84	199	1.25	32	1.01	25.65	3.19	81	3.15	1.43	10
1-1/2	40	6.18	157	9.40	239	3.41	86.6	7.51	191	8.94	227	1.50	38	1.38	35	4.42	112.3	4.5	2.04	10
2	50	6.44	163.6	11.54	293	3.42	86.9	9.65	245	10.84	275	2.00	51	1.51	38.3	4.42	112.3	6.7	3.04	4
2-1/2	65	7.56	192	14.4	366	4.62	117.3	11.86	301	13.52	343	2.50	64	1.47	37.3	4.42	112.3	11.9	5.4	4
3	80	8.49	215.6	16.6	422	5.17	131.3	13.89	353	15.65	398	3.00	76	1.66	42.2	5.28	134.1	18.6	8.44	4

† 200 psi for 2 1/2" and 3"

‡ No packing gland, packing only in this size.

**WARNING:** This product can expose you to chemicals including lead, which is known to the State of California to cause cancer and birth defects or other reproductive harm. For more information go to [www.P65Warnings.ca.gov](http://www.P65Warnings.ca.gov).

Visit our website for the most current information.

LEAD-FREE: Weighted average lead content ≤ 0.25%

# NIBCO® Press System Bronze Gate Valves

Screw-In Bonnet • Non-Rising Stem • Solid Wedge

**200 psi/13.8 bar non-shock cold working pressure**  
**250°F maximum operating temperature**

CONFORMS TO MSS SP-80/139

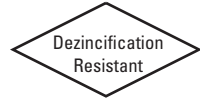

## MATERIAL LIST

PART	SPECIFICATION
1. Handwheel Nut	300 Series Stainless Steel
2. Identification Plate	Aluminum
3. Handwheel	Malleable Iron ASTM A 47
4. Stem	Silicon Bronze ASTM B 371 Alloy C69430 or ASTM B 99 Alloy C65100
5. Pack Nut	Brass ASTM B 16 Alloy C36000
6. Pack Gland	Brass ASTM B 16 Alloy C36000
7. Packing	Aramid Fibers with Graphite
8. Stuffing Box	Bronze ASTM B 62 Alloy C83600
9. Bonnet	Bronze ASTM B 62 Alloy C83600
10. Body Assembly	Bronze ASTM B 62 Alloy C83600
11. Wedge	Bronze ASTM B 62 Alloy C83600
12. Female Adapter (2)	Wrot Copper ASTM B75 Alloy C12200
13. O-Ring (2)	EPDM



**PF-113**

Press x Press  
Female End

## DIMENSIONS—WEIGHTS

Size	Dimensions						Weight		
	A		B		C		Lbs.	Kg.	
In.	mm.	In.	mm.	In.	mm.	In.	mm.		
½ †	15	1.97	50	3.63	92	.50	13	.78	.36
¾	20	2.62	67	3.91	99	.75	19	1.21	.55
1	25	3.07	78	4.69	119	1.00	25	1.92	.88
1¼	32	3.36	85	5.22	133	1.25	32	2.69	1.22
1½	40	3.70	94	6.25	159	1.50	38	3.91	1.78
2	50	4.28	109	7.06	179	2.00	51	6.21	2.83

† No packing gland, packing only in this size.

NIBCO Press end gate valves are designed to MSS SP-80 with the exception of Press connections designed to MSS SP-139. Valves with Press ends are rated to align with NIBCO Press System max pressure.

**⚠ WARNING:** This product can expose you to chemicals including lead, which is known to the State of California to cause cancer and birth defects or other reproductive harm. For more information go to [www.P65Warnings.ca.gov](http://www.P65Warnings.ca.gov).

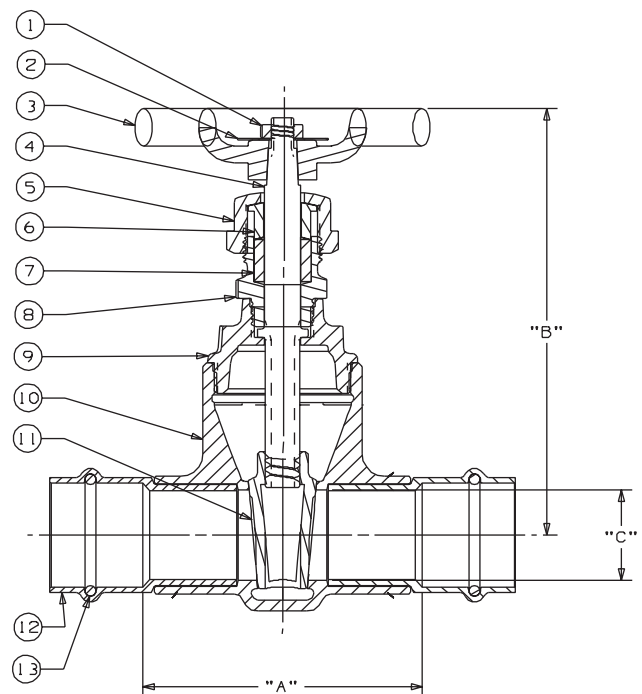

**PF-113**  
P x P

Visit our website for the most current information.

# NIBCO® Press System Lead-Free Bronze Gate Valves

Silicon Performance Bronze® Alloy • Screw-In Bonnet • Non-Rising Stem •  
Conforms to MSS SP-139 • Solid Wedge • Press Ends Leak Detection

**Pressure rating: 250<sup>†</sup> psi non-shock cold working pressure**  
**Maximum pressure / temperature: 150 psi at 250° F**

Lead-Free markings:  
Double oval in body casting, white handle and blue hang tag

NSF/ANSI/CAN 61-8 Commercial Hot 180°F • NSF/ANSI/  
CAN 372



NSF/ANSI/CAN 372



## MATERIAL LIST

PART	SPECIFICATION
1. Handwheel Nut	300 Series Stainless Steel
2. Handwheel	Malleable Iron ASTM A47, 35018
3. Stem	Silicon Bronze ASTM B371 Alloy C69430
4. Packing Gland	ASTM B16 C36000
5. Stem Packing	Aramid Fibers with Graphite
6. Packing Nut	ASTM B16 C36000
7. Stuffing Box	Silicon Bronze ASTM B584 Alloy C87850
8. Bonnet	Silicon Bronze ASTM B584 Alloy C87850
9. Body	Silicon Bronze ASTM B584 Alloy C87850
10. Wedge	Silicon Bronze ASTM B584 Alloy C87850
11. Identification Plate	Aluminum
12. Boss seal o-ring (2)	EPDM
13. Press End Adapter (2)	Wrot Copper ASTM B75 Alloy C12200
14. Crimp Evident Seal (2)	EPDM - Leak Detection

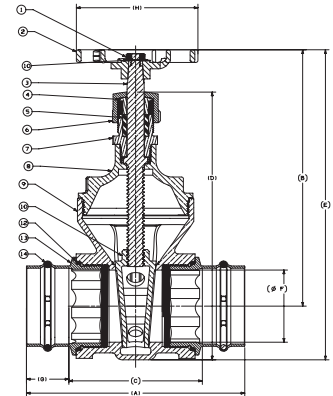

**PC-113-LF**  
Press x Press  
Female End

## DIMENSIONS—WEIGHTS—QUANTITIES

SIZE		A		B		C		D		E		F		G		H		Weight		Master
In.	mm.	In.	mm.	In.	mm.	In.	mm.	In.	mm.	In.	mm.	In.	mm.	In.	mm.	In.	mm.	Lbs.	Kg.	Ctn Qty.
1/2 <sup>‡</sup>	15	3.68	93.47	3.66	93	2.28	57.9	3.34	84.84	4.24	107.7	0.5	13	0.7	17.78	2.44	62	0.91	0.41	30
3/4	20	4.24	107.7	3.94	100	2.36	59.9	3.85	97.8	4.64	118	0.75	19	0.96	24	2.44	62	1.28	0.58	25
1	25	4.62	117.3	4.62	117.3	2.85	72.4	4.69	119	5.52	140	1.00	25	0.88	22.35	3.19	81	2.09	0.95	20
1-1/4	32	5.1	129.5	5.19	132	3.08	78.2	5.26	133.6	6.25	159	1.25	32	1.01	25.65	3.19	81	3.03	1.37	10
1-1/2	40	6.18	157	6.3	160	3.41	86.6	6.07	154.2	7.5	191	1.50	38	1.38	35	4.42	112.3	4.18	1.9	10
2	50	6.44	163.6	7.09	180	3.42	86.9	7.33	186.2	8.59	218	2.00	51	1.51	38.3	4.42	112.3	6.1	2.77	4
2-1/2	65	7.56	192	8.88	226	4.62	117.3	9.28	235.7	10.69	272	2.50	64	1.47	37.3	4.42	112.3	11.2	5.08	4
3	80	8.49	215.6	10.24	261	5.17	131.3	10.71	272	12.5	318	3.00	76	1.66	42.2	5.28	134.1	17.37	7.89	4

<sup>†</sup> 200 psi for 2 1/2" and 3"

<sup>‡</sup> No packing gland, packing only in this size.

**WARNING:** This product can expose you to chemicals including lead, which is known to the State of California to cause cancer and birth defects or other reproductive harm. For more information go to [www.P65Warnings.ca.gov](http://www.P65Warnings.ca.gov).

Visit our website for the most current information.

LEAD-FREE: Weighted average lead content ≤ 0.25%

# NIBCO<sup>®</sup> Press System Bronze Globe Valves

Screw-In Bonnet • Integral Seat • Renewable Seat and Disc

**200 psi/13.8 bar non-shock cold working pressure**  
**250°F maximum operating temperature**

CONFORMS TO MSS SP-80/139

## MATERIAL LIST

PART	SPECIFICATION
1. Handwheel Nut	300 Series Stainless Steel
2. Identification Plate	Aluminum
3. Handwheel	Malleable Iron ASTM A 47
4. Stem	Silicon Bronze ASTM B 371 Alloy C69430
5. Pack Gland	Brass ASTM B 16 Alloy C36000
6. Pack Nut	Brass ASTM B 16 Alloy C36000
7. Packing	Aramid Fibers with Graphite
8. Bonnet	Bronze ASTM B 62 Alloy C83600
9. Disc Holder Nut	Bronze ASTM B 62 Alloy C83600
10. Disc Holder	Bronze ASTM B 62 Alloy C83600
11. Disc	PTFE
12. Disc Washer	304 Stainless Steel
13. Disc Nut	Bronze ASTM B 98 Alloy C65100
14. Body Assembly	Bronze ASTM B62 Alloy C83600
15. Female Adapter (2)	Wrot Copper ASTM B75 Alloy C12200
16. O-Ring (2)	EPDM



## PF-211-Y

Press x Press  
Female End

## DIMENSIONS—WEIGHTS

Size	Dimensions						Weight		
	A		B		C		Lbs.	Kg.	
In.	mm.	In.	mm.	In.	mm.	In.	mm.		
*1/2 <sup>†</sup>	15	2.91	74	3.38	86	.50	13	1.07	.48
3/4	20	3.99	101	4.88	124	.75	19	2.04	.93
1	25	4.88	124	5.69	145	1.00	25	3.13	1.42
1 1/4	32	5.23	133	6.13	156	1.25	32	4.00	1.82
1 1/2	40	6.01	153	7.38	187	1.50	38	6.44	2.93
2	50	7.41	188	7.94	202	2.00	51	10.16	4.62

<sup>†</sup> No packing gland, packing only in this size.

\* Stem and disc (or disc holder) are integral.

NIBCO Press end gate valves are designed to MSS SP-80 with the exception of Press connections designed to MSS SP-139. Valves with Press ends are rated to align with NIBCO Press System max pressure.

**⚠ WARNING:** This product can expose you to chemicals including lead, which is known to the State of California to cause cancer and birth defects or other reproductive harm. For more information go to [www.P65Warnings.ca.gov](http://www.P65Warnings.ca.gov).

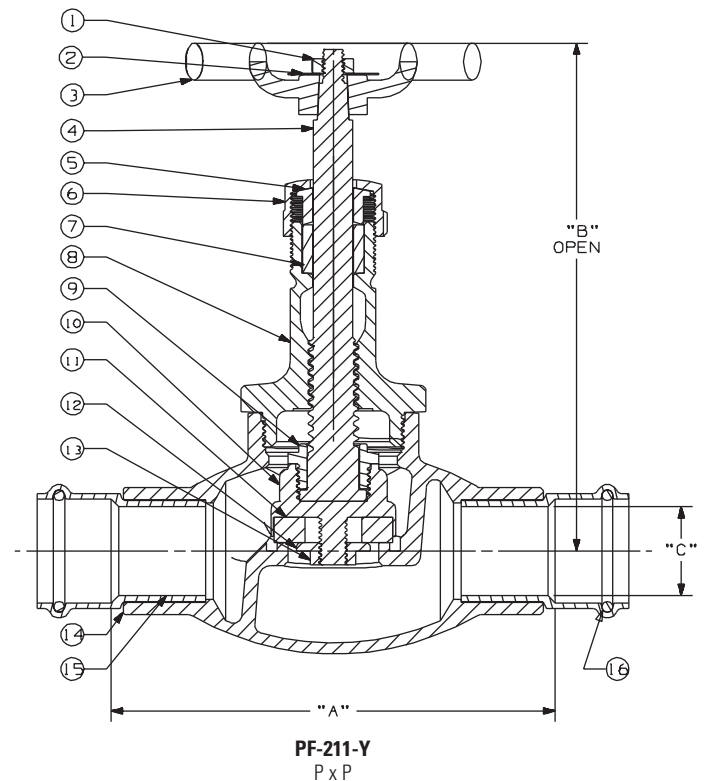

Visit our website for the most current information.

# NIBCO® Press System Bronze Angle Valves

Screw-In Bonnet • Integral Seat • Renewable Seat and Disc

**200 psi/13.8 bar non-shock cold working pressure**  
**250°F maximum operating temperature**

CONFORMS TO MSS SP-80/139



## MATERIAL LIST

PART	SPECIFICATION
1. Handwheel Nut	300 Series Stainless Steel
2. Identification Plate	Aluminum
3. Handwheel	Malleable Iron ASTM A 47
4. Stem	Silicon Bronze ASTM B 371 Alloy C69430
5. Pack Gland	Brass ASTM B 16 Alloy C36000
6. Pack Nut	Brass ASTM B 16 Alloy C36000
7. Packing	Aramid Fibers with Graphite
8. Bonnet	Bronze ASTM B 62 Alloy C83600
9. Disc Holder Nut	Bronze ASTM B 62 Alloy C83600
10. Disc Holder	Bronze ASTM B 62 Alloy C83600
11. Disc	PTFE
12. Disc Washer	304 Stainless Steel
13. Disc Nut	Silicon Bronze ASTM B 96 Alloy C65100
14. Body	Bronze ASTM B 62 Alloy C83600
15. Female Adapter (2)	Wrot Copper ASTM B75 Alloy C12200
16. O-Ring (2)	EPDM



**PF-311-Y**  
Press x Press  
Female End

## DIMENSIONS—WEIGHTS

Size	Dimensions				Weight	
	B		H			
In. mm.	In. mm.	In. mm.	In. mm.	In. mm.	Lbs.	Kg.
*1/2†	15 3.50	89 1.49	38 1.49	38 1.49	1.07	.48
3/4	20 4.94	126 2.00	51 2.00	51 2.00	1.94	.88
1	25 5.75	146 2.48	63 2.48	63 2.48	3.12	1.42
1 1/4	32 6.13	156 2.59	66 2.59	66 2.59	4.21	1.92
1 1/2	40 7.25	179 2.98	76 2.98	76 2.98	5.44	2.47
2	50 8.13	206 3.64	93 3.64	93 3.64	9.98	4.54

† No packing gland, packing only in this size.

\* Stem and disc or disc holder are integral.

NIBCO Press end gate valves are designed to MSS SP-80 with the exception of Press connections designed to MSS SP-139. Valves with Press ends are rated to align with NIBCO Press System max pressure.

**⚠ WARNING:** This product can expose you to chemicals including lead, which is known to the State of California to cause cancer and birth defects or other reproductive harm. For more information go to [www.P65Warnings.ca.gov](http://www.P65Warnings.ca.gov).

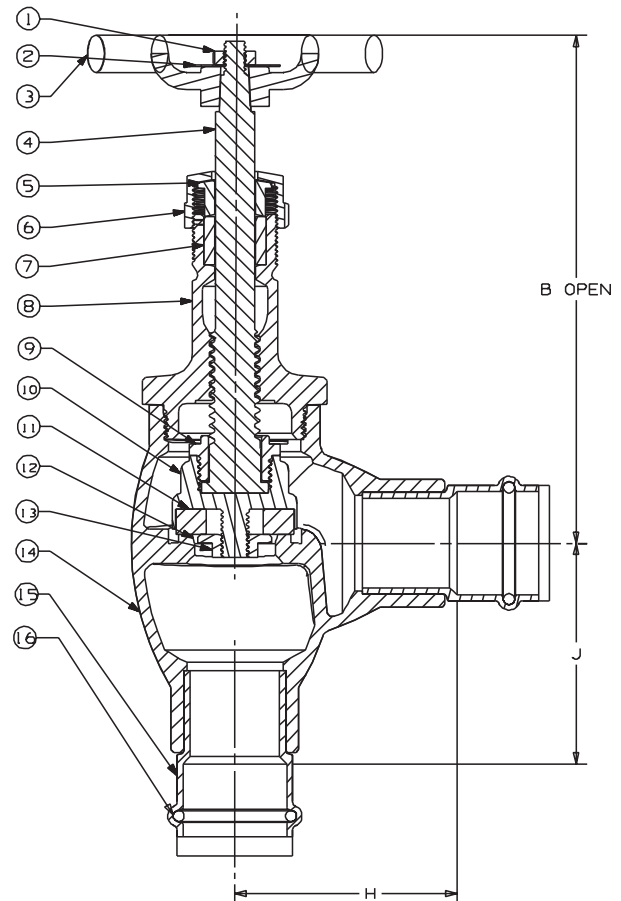

**PF-311-Y**  
P x P

Visit our website for the most current information.

# Lead-Free Bronze Check Valves

Silicon Performance Bronze® Alloy • Horizontal Swing • Regrinding Type • Y-Pattern • Renewable Seat and Disc • Conforms to MSS SP-139 • Press Ends

**Pressure rating: 200 psi non-shock cold working pressure**  
**Maximum pressure / temperature: 125 psi at 250° F**

Lead-Free marking:  
Double oval in body casting

NSF/ANSI/CAN 61-8 Commercial Hot 180°F • NSF/ANSI/CAN 372



NSF/ANSI/CAN 372

## MATERIAL LIST

PART	SPECIFICATION
1. Bonnet	Silicon Bronze ASTM B584 Alloy C87850
2. Body	Silicon Bronze ASTM B584 Alloy C87850
3. Hinge Pin	ASTM A276 Alloy S31600 or ASTM A276 Alloy S30400
4. Disc Hanger	Silicon Bronze ASTM B584 Alloy C87850
5. Stainless Steel Nut (2)	ASTM F594 Alloy S31600 or ASTM F594 Alloy S30400
6. Disc Holder	Silicon Bronze ASTM B371 Alloy C69300
7. Seat Disc	PTFE
8. Hinge Pin Plug	ASTM B371 Alloy C69300
*9. Disc Washer	304 Stainless Steel
10. Boss Seal O-ring (2)	EPDM
11. Press End Adapter (2)	ASTM B75 Alloy C12200
12. Crimp Evident Seal (2)	EPDM - Leak Detection

\*Sizes ¾", 1", 1½", 1½" and 2" only



**PC-413-Y-LF**  
Press Ends

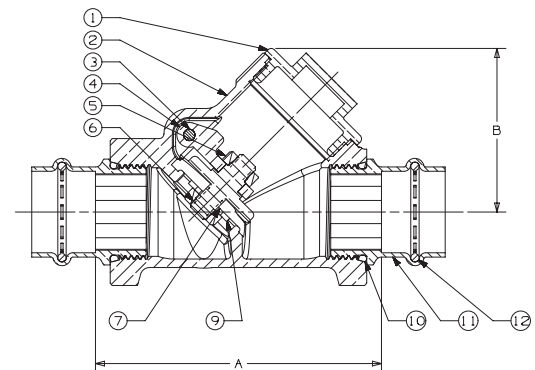

**PC-413-Y-LF**  
Press x Press

## DIMENSIONS—WEIGHTS

SIZE	Dimensions						Master Ctn Qty	Weight	
	A (Lay Length)		B (Height)		Lbs.	Kg.			
½	15	2.78	71	1.66			42	40	0.72
¾	20	3.25	83	1.90	48	40	1.13	0.51	
1	25	3.97	101	2.27	58	25	1.80	0.82	
1¼	32	4.64	118	2.67	68	20	2.42	1.10	
1½	40	5.00	127	3.09	79	16	3.75	1.70	
2	50	5.85	149	3.84	98	4	5.51	2.50	

NIBCO® check valves may be installed in both horizontal and vertical lines with upward flow or in any intermediate position. They will operate satisfactorily in a declining plane (no more than 15°). Install check valves as far from pump discharge or line direction change as possible and at a minimum length of 5 times the pipe diameter.

Do not use for reciprocating air compressor service.

**WARNING:** This product can expose you to chemicals including lead, which is known to the State of California to cause cancer and birth defects or other reproductive harm. For more information go to [www.P65Warnings.ca.gov](http://www.P65Warnings.ca.gov).

LEAD-FREE: Weighted average lead content ≤ 0.25%

Visit our website for the most current information.

# Lead-Free Bronze Ring Check® Valves

**Features:** Silicon Performance Bronze® Alloy • Inline Lift Type • Resilient Discs • Spring Actuated

**Approvals:** Conforms to MSS SP-139 • NSF/ANSI/CAN 61-8 Commercial Hot 180°F and NSF/ANSI/CAN 372

**Size range:** 1/2" - 2"

**Pressure rating:** 250 PSI non-shock cold working pressure

**Maximum pressure / temperature:** 140 PSI at 250° F

Lead-free marking: Double oval in body casting



NSF/ANSI/CAN 372

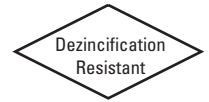

**PC-480-Y-LF**  
**PC-480-W-LF**  
Press Ends

## MATERIAL LIST

PART	SPECIFICATION
1. Spring	Stainless Steel S31600
2. Seat Screw	Stainless Steel 18-8
3. Stem	Stainless Steel ASTM A582 Alloy S30300
4. Disk Holder	Stainless Steel 18-8
5. Disk	(Y) PTFE (W) BUNA-N
6. Press End Adapter	ASTM B75 Alloy C12200
7. Crimp Evident Seal (2)	EPDM
8. Boss Seal O-ring (2)	EPDM - Leak Detection
9. Body	Silicon Bronze ASTM B584 Alloy C87600
10. Body End	Silicon Bronze ASTM B584 Alloy C87600

## DIMENSIONS—WEIGHTS—QUANTITIES

SIZE		A		B		C		PC-480-Y-LF		Master
In.	mm.	In.	mm.	In.	mm.	In.	mm.	Lbs.	Kg.	Ctn Qty.
1/2	15	3.647	93	1.570	40	2.251	57	0.48	0.22	100
3/4	20	4.438	113	1.860	47	2.518	64	0.69	0.31	100
1	25	4.640	118	2.360	60	2.870	73	1.07	0.48	50
1 1/4	32	5.117	130	2.680	68	3.097	79	1.53	0.69	30
1 1/2	40	6.314	160	3.060	78	3.544	90	2.12	0.96	30
2	50	7.084	180	3.720	94	4.064	103	3.40	1.54	10

SIZE		A		B		C		PC-480-W-LF		Master
In.	mm.	In.	mm.	In.	mm.	In.	mm.	Lbs.	Kg.	Ctn Qty.
1/2	15	3.647	93	1.570	40	2.251	57	0.48	0.22	100
3/4	20	4.438	113	1.860	47	2.518	64	0.69	0.31	100
1	25	4.640	118	2.360	60	2.870	73	1.06	0.48	50
1 1/4	32	5.117	130	2.680	68	3.097	79	1.52	0.69	30
1 1/2	40	6.314	160	3.060	78	3.544	90	2.11	0.96	30
2	50	7.084	180	3.720	94	4.064	103	3.38	1.53	10

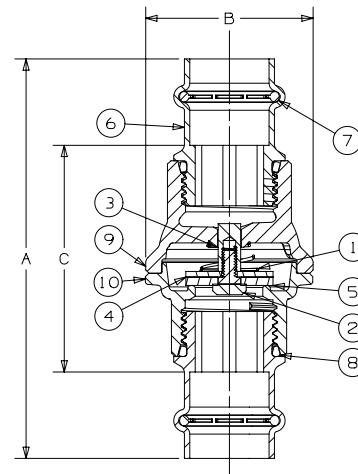

**PC-480-Y-LF**  
**PC-480-W-LF**  
Press x Press

Sizes 1/2" thru 2" require 1/2 pound pressure to open.

Install 5 Pipe diameters minimum downstream from pump discharge or changes in direction to avoid flow turbulence. Flow straighteners may be required in extreme cases.

NIBCO In-line check valves may be installed in both horizontal and vertical lines, or in any intermediate position.

Do not use for reciprocating air compressor service.



**WARNING:** This product can expose you to chemicals including lead, which is known to the State of California to cause cancer and birth defects or other reproductive harm. For more information go to [www.P65Warnings.ca.gov](http://www.P65Warnings.ca.gov).

Visit our website for the most current information.

LEAD-FREE: Weighted average lead content ≤ 0.25%

# NIBCO® Press System Bronze Check Valves

Horizontal Swing • Regrinding Type • Y-Pattern • Renewable Seat and Disc

**200 psi/13.8 bar non-shock cold working pressure**

**250°F maximum operating temperature**

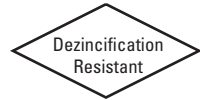

CONFORMS TO MSS SP-80/139

## MATERIAL LIST

PART	SPECIFICATION
1. Bonnet	Bronze ASTM B 62 Alloy C83600
2. Body	Bronze ASTM B 62 Alloy C83600
3. Hinge Pin	Bronze ASTM B 140 Alloy C31400
4. Disc Hanger	Bronze ASTM B 62 Alloy C83600 or 304 SS 1/2" and 3/4" sizes only
5. Hanger Nut	Brass ASTM B 16 Alloy C36000
6. Disc Holder	Bronze ASTM B 62 Alloy C83600
7. Seat Disc	PTFE
8. Seat Disc Nut	Brass ASTM B 16 Alloy C36000
9. Hinge Pin Plug	Bronze ASTM B 140 Alloy C32000 (not shown)
*10. Seat Disc Washer	ASTM B 98 Alloy C65500 or ASTM B 103
11. Female Adapter (2)	Wrot Copper ASTM B75 Alloy C12200
12. O-Ring (2)	EPDM

\* Sizes 3/4" thru 2" only



**PF-413-Y**  
Press x Press  
Female End

## DIMENSIONS—WEIGHTS

### Dimensions

Size	A		B		Weight		
	In.	mm.	In.	mm.	Lbs.	Kg.	
1/2	15	2.72	69	1.54	39	.58	.26
3/4	20	3.62	92	1.83	46	.96	.44
1	25	4.32	110	2.21	56	1.51	.69
1 1/4	32	4.92	125	2.69	68	2.29	1.04
1 1/2	40	5.58	142	2.94	75	3.30	1.50
2	50	6.72	171	3.61	92	5.45	2.48

NIBCO Press end gate valves are designed to MSS SP-80 with the exception of Press connections designed to MSS SP-139. Valves with Press ends are rated to align with NIBCO Press System max pressure.

**WARNING** — Do not use for reciprocating air compressor service

NIBCO check valves may be installed in both horizontal and vertical lines with upward flow or in any intermediate position. They will operate satisfactorily in a declining plane (no more than 15°).

**WARNING:** This product can expose you to chemicals including lead, which is known to the State of California to cause cancer and birth defects or other reproductive harm. For more information go to [www.P65Warnings.ca.gov](http://www.P65Warnings.ca.gov).

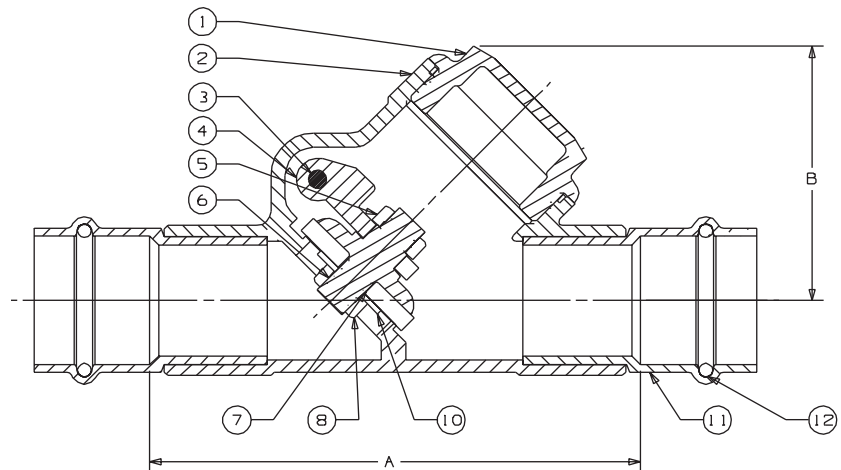

**PF-413-Y**  
P x P

Visit our website for the most current information.

# NIBCO® Press System Bronze In-line Lift Check Valves

In-Line Lift Type • Resilient Discs • Spring Actuated

**200 psi/17.2 bar non-shock cold working pressure**  
**250°F maximum operating temperature**

Dezincification  
Resistant

## MATERIAL LIST

PART	SPECIFICATION
1. Body	Bronze ASTM B584 Alloy C84400
2. Stem	Stainless Steel ASTM A582 Alloy C30300
3. Spring	316 Stainless Steel
4. Disc Holder	Stainless Steel Type 301
5. Disc	PTFE
6. Seat Screw	Stainless Steel ASTM A276 Alloy S43000
7. Body End	Bronze ASTM B584 Alloy C84400
8. Adapter (2)	Wrot Copper ASTM B75 Alloy C12200
9. O-Ring (2)	EPDM



## PF-480-Y

Press x Press  
Female End

## DIMENSIONS—WEIGHTS

Size	Dimensions						Weight		
	A		B		C		Lbs.	Kg.	
In.	mm.	In.	mm.	In.	mm.	In.	mm.		
1/2	15	2.41	61	1.38	35	.50	13	0.52	0.24
3/4	20	3.05	77	1.63	41	.75	19	0.75	0.34
1	25	3.56	90	2.00	51	1.00	25	1.18	0.54
1 1/4	32	3.86	98	2.38	60	1.25	32	1.72	0.78
1 1/2	40	4.45	113	2.75	70	1.50	38	2.49	1.13
2	50	5.28	134	3.38	86	2.00	51	3.96	1.80

NIBCO Press System check valves may be installed in both horizontal and vertical lines with upward flow or in any intermediate position.

**WARNING - Do Not Use for reciprocating air compressor service.**

**NOTE: 0.5 psi pressure required to open spring.**

**NOTE: Check valves are down-rated from 250 psi CWP to 200 psi CWP to match the Press System.**

**⚠ WARNING:** This product can expose you to chemicals including lead, which is known to the State of California to cause cancer and birth defects or other reproductive harm. For more information go to [www.P65Warnings.ca.gov](http://www.P65Warnings.ca.gov).

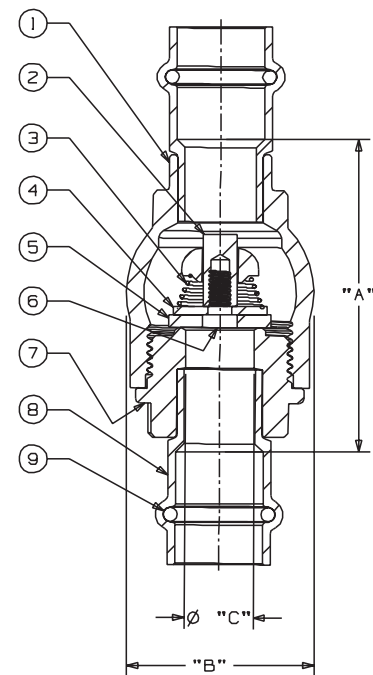

PF-480-Y (PTFE Disc)  
P x P

Visit our website for the most current information.

# NIBCO® Press System Butterfly Valves

Ductile Iron Body • Extended Neck • Geometric Drive  
Molded-In Seat Liner • Lug Style with Press x Press Female Ends

**200 psi/13.8 bar non-shock cold working pressure**  
**250°F maximum operating temperature**

CONFORMS TO MSS-SP67 • MSS-SP25 • API-609 •  
NSF/ANSI/CAN 61-8 COMMERCIAL HOT 180°F AND NSF/  
ANSI/CAN 372

## MATERIAL LIST

PART	SPECIFICATION
1. Stem	Stainless Steel ASTM A 582 Type 416
2. Collar Bushing	Brass ASTM B 124
3. Stem Seal	EPDM Rubber
4. Body Seal	EPDM Rubber
5. Nameplate	Aluminum
6. Upper Bushing	Wrot Copper ASTM B 75 Alloy C12200
7. Liner	EPDM Rubber
8. Disc	Alum. Brz. ASTM B 148 Alloy 954/955
9. Lower Bushing	Wrot Copper ASTM B 75 Alloy C12200
10. Body Lug	Ductile Iron ASTM A 536
11. Flange Body (2)	Carbon Steel
12. Flange Gasket (2)	EPDM
13. Flange Press Ends (2)	Wrot Copper ASTM B 75 Alloy C12200
14. Crimp Evident Seal (2)	EPDM - Leak Detection
15. Cap Screws	Carbon Steel

Available with lock lever handle or gear operator.

## DIMENSIONS — WEIGHTS

Size	A	B	C	D	E	F	G	Metal	Rubber
In. mm.							Flat	H	I
2½ 65	2.90	4.69	1.25	5.88	3.27	.38	.370	1.812	1.938
3 80	3.15	5.12	1.25	6.12	3.40	.38	.370	1.812	1.938
4 100	4.09	6.12	1.25	6.88	4.00	.38	.403	2.062	2.188

Size	J	N	O	P	R	S	Lug Length	Total Weight
In. mm.	Square	Dia.	B.C.	Dia.	Dia.	No.		Lbs. Kg.
2½ 65	3.25	.562	3.25	.437	.500	3.13	Refer to page 68 for bolt lengths	24.00 10.88
3 80	3.25	.562	3.25	.437	.500	3.44		26.00 11.78
4 100	3.25	.625	3.25	.437	.562	4.00		38.00 17.23

NIBCO Press System butterfly valves are designed to meet MSS SP-67 with the exception of the end connection. Male and female press-to-connect ends are new technology not yet covered in the current edition of this specification.

**⚠ WARNING:** This product can expose you to chemicals including lead, which is known to the State of California to cause cancer and birth defects or other reproductive harm. For more information go to [www.P65Warnings.ca.gov](http://www.P65Warnings.ca.gov).

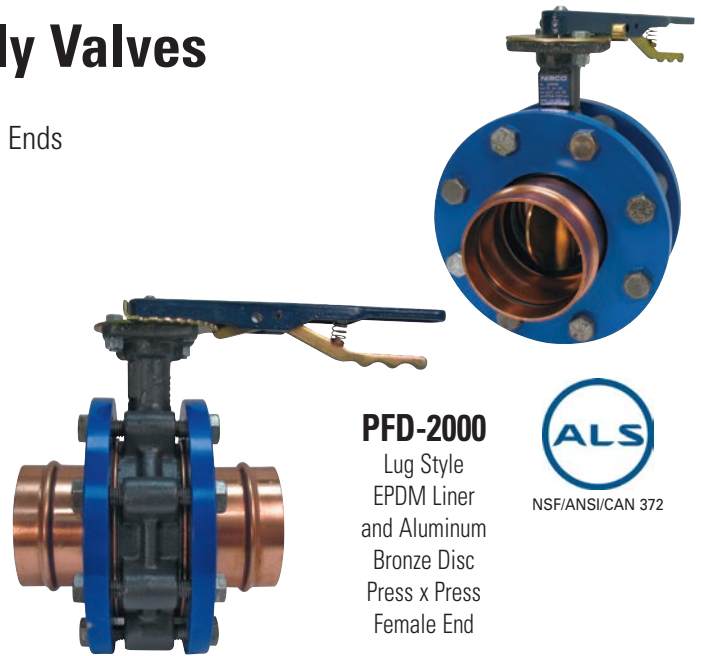

## PFD-2000

Lug Style  
EPDM Liner  
and Aluminum  
Bronze Disc  
Press x Press  
Female End



NSF/ANSI/CAN 372

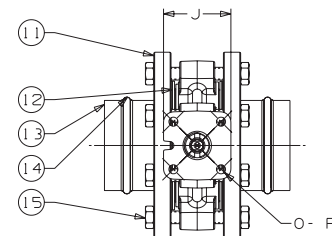
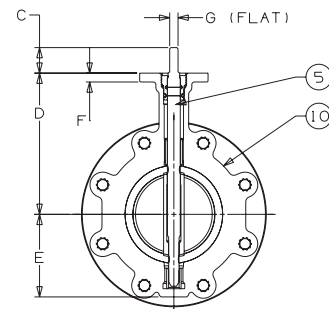
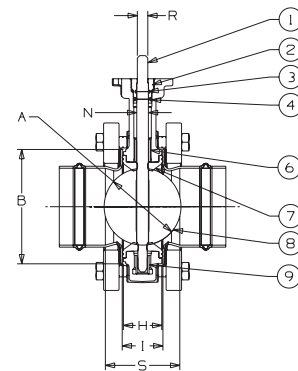

NOT RECOMMENDED  
FOR STEAM SERVICE

Visit our website for the most current information.

# NIBCO® Press System Bronze Ball Valves

Two-Piece Body • Full Port • Bronze Trim • Blowout-Proof Stem

**Bar non-shock cold working pressure**

**Maximum Pressure/Temperature: 200 psi at 250°F**



CONFORMS TO MSS SP-110

## MATERIAL LIST

PART	SPECIFICATION
1. Handle Nut	Zinc Plated Steel
2. Handle Assembly	Zinc Plated Steel with Plastisol Cover
3. Pack Gland	Brass ASTM B 16 Alloy C36000
4. Packing	PTFE
5. Stem	Silicon Bronze ASTM B 371 Alloy C69430 or B371 Alloy C69300
6. Thrust Washer	RPTFE
7. Ball	Brass ASTM B 16 Alloy C36000 or ASTM B 124 Alloy C37700 (Chrome/Nickle Plated)
8. Seat Ring (2)	RPTFE
9. Body	Bronze ASTM B 584 Alloy C84400
10. Body End Piece	Bronze ASTM B 584 Alloy C84400
11. Stub Out (2)	Type "L" Copper Tube



**PS-585-70**  
Press x Press  
Male End

## DIMENSIONS—WEIGHTS

Size	Dimensions								Weight		
	A		B		C		D				
In.	mm.	In.	mm.	In.	mm.	In.	mm.	In.	mm.	Lbs.	Kg.
½	15	6.56	167	1.88	48	7.25	184	.50	13	.73	.99
¾	20	7.25	184	2.25	57	8.25	210	.75	19	1.50	.68
1	25	7.75	197	2.38	60	8.63	219	1.00	25	2.05	.93
1¼	32	9.06	230	3.00	76	9.19	233	1.25	32	3.64	1.65
1½	40	9.99	254	3.16	80	11.69	297	1.50	38	5.73	2.60
2	50	10.72	272	3.50	89	12.06	306	2.00	51	8.11	3.68

NIBCO Press System ball valves are designed to meet MSS SP-110 with the exception of the end connection. Ball valves are down-rated from 600 psi CWP to 200 psi CWP to match the NIBCO Press System. Male and female press-to-connect ends are new technology not yet covered in the current edition of this specification.

**⚠ WARNING:** This product can expose you to chemicals including lead, which is known to the State of California to cause cancer and birth defects or other reproductive harm. For more information go to [www.P65Warnings.ca.gov](http://www.P65Warnings.ca.gov).

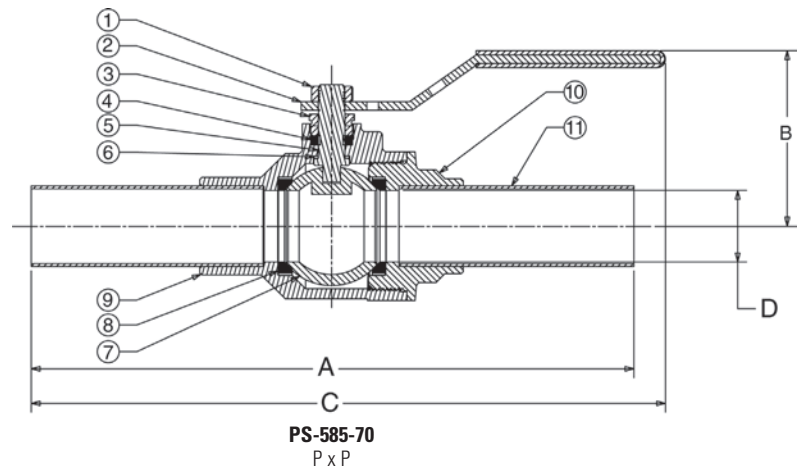

**PS-585-70**  
P x P

Visit our website for the most current information.

# NIBCO® Press System Bronze Ball Valves

Two-Piece Body • Full Port • Stainless Trim • Blowout-Proof Stem • Vented Ball

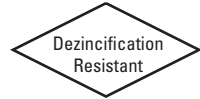

**Bar non-shock cold working pressure**

**Maximum Pressure/Temperature: 200 psi at 250°F**

CONFORMS TO MSS SP-110/145

## MATERIAL LIST

PART	SPECIFICATION
1. Body	Bronze ASTM B 584 Alloy C84400
2. Body End Piece	Bronze ASTM B 584 Alloy C84400
3. Ball	ASTM A 276 Alloy S31600 Stainless Steel
4. Seat Ring (2)	RPTFE
5. Stem	ASTM A 276 Alloy S31600 Stainless Steel
6. Thrust Washer	PTFE
7. Pack Gland	ASTM B 16 Alloy C36000
8. Stem Packing	PTFE
9. Handle Assembly	Zinc Plated Steel with Plastisol Cover
10. Nut	Stainless Steel 300 Series
11. Stub Out (2)	15" Type "L" Copper Tube



**PS-585-70-66**

Press x Press  
Male End

## DIMENSIONS—WEIGHTS

Size	Dimensions					Weight					
	A	B	C	D	Lbs.	Kg.					
1/2	15	6.56	167	1.88	48	7.25	184	.50	13	.73	.33
3/4	20	7.25	184	2.25	57	8.25	210	.75	19	1.50	.68
1	25	7.75	197	2.38	60	8.63	219	1.00	25	2.05	.93
1 1/4	32	35.05	890	3.10	78	24.28	616	1.25	32	3.86	1.75
1 1/2	40	9.99	254	3.16	80	11.69	297	1.50	38	5.79	2.63
2	50	36.72	932	3.56	90	25.11	638	2.00	51	8.84	4.00

NIBCO Press end ball valves are designed to MSS SP-110 with the exception of Press connections are designed to MSS SP-145. Valves with Press ends are rated to align with NIBCO Press System max pressure.

**WARNING:** This product can expose you to chemicals including lead, which is known to the State of California to cause cancer and birth defects or other reproductive harm. For more information go to [www.P65Warnings.ca.gov](http://www.P65Warnings.ca.gov).

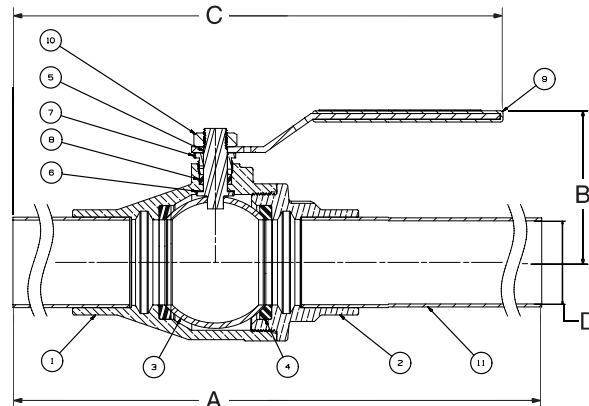

**PS-585-70-66**  
A x A

Visit our website for the most current information.

# NIBCO® Press System Bronze Ball Valves

Two-Piece Body • Full Port • Bronze Trim • ¾" Hose Connection with Cap and Retainer  
• Blowout-Proof Stem

**Bar non-shock cold working pressure**

**Maximum Pressure/Temperature: 200 psi at 250°F**

CONFORMS TO MSS SP-110/145

## MATERIAL LIST

PART	SPECIFICATION
1. Handle Nut	Zinc Plated Steel
2. Handle	Zinc Plated Steel
3. Pack Gland	Brass ASTM B 16 Alloy C36000
4. Packing	PTFE
5. Thrust Washer	RPTFE
6. Stem	Silicon Bronze ASTM B 371 Alloy C69430
7. Ball	Brass ASTM B 16 Alloy C36000 or ASTM B 124 Alloy C37700 (Chrome/Nickle Plated)
8. Seat Rings	Reinforced PTFE
9. Body Assembly	Bronze ASTM B 584 Alloy C84400
10. Hose Body End	Brass ASTM B 124 Alloy C37700
11. Hose Cap Assembly*	Die Cast Brass, EPDM Gasket, Soft PVC Retainer
12. Stub Out	Type "L" Copper Tube

\* Cap is for hose end thread protection only. Not to be used for pressure containing purposes.



**PS-585-70-HC**  
Press Male x Hose End

## DIMENSIONS—WEIGHTS

Size	Dimensions						Weight	
	A		B		C		Lbs.	Kg.
In. mm.	In.	mm.	In.	mm.	In.	mm.		
½ 15	4.90	124	1.88	48	7.19	183	.81	.37
¾ 20	5.47	139	2.25	57	8.25	210	1.54	.70

NIBCO Press end gate valves are designed to MSS SP-110 with the exception of Press connections designed to MSS SP-145. Valves with Press ends are rated to align with NIBCO Press System max pressure.

**WARNING:** This product can expose you to chemicals including lead, which is known to the State of California to cause cancer and birth defects or other reproductive harm. For more information go to [www.P65Warnings.ca.gov](http://www.P65Warnings.ca.gov).

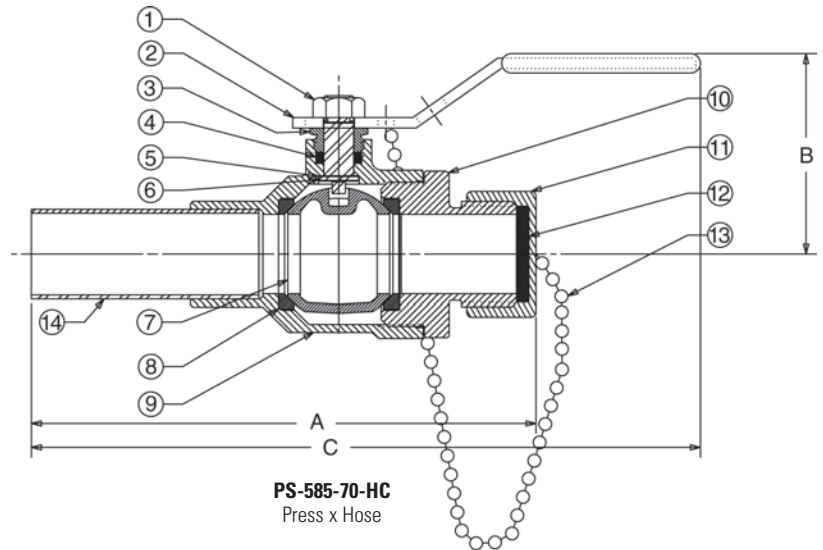

**PS-585-70-HC**  
Press x Hose

Visit our website for the most current information.

# Class 125 Bronze Y-Strainers

Screw-In Cap • Tapped Cap with Blow-Off Plug or Solid Cap •  
20 Mesh SS Screen or SS Perforated Screen • Press Ends Leak Detection

**200 psi/13.8 bar non-shock cold working pressure**  
**250° F maximum operating temperature**

## MATERIAL LIST

PART	SPECIFICATION
1. Body	Bronze ASTM B584 Alloy C84400
2. Cap	Bronze ASTM B62 Alloy C83600
3. Gasket	PTFE
4. Screen	ASTM E2016 20 Mesh - 304 Stainless Steel or ASTM E674 Perforated - 304 Stainless Steel
5. Plug	Brass ASTM B16 Alloy C36000 or Bronze ASTM B584 Alloy C84400
6. Female Adapter (2)	Wrot Copper ASTM B75 Alloy C12200
7. O-Ring (2)	EPDM - Leak Detection

END CONNECTION	SCREEN	CAP
PF- Female Press	221 - 20 Mesh (STD.)	A - Tapped Cap w/Plug (STD.)
PF - Female Press	222 - Perforated	B - Solid Cap

## DIMENSIONS—WEIGHTS—QUANTITIES

Dimensions								
Size		A		C		D	Weight	
In.	mm.	In.	mm.	In.	mm.	Threads	Lbs.	Kg.
½	15	3.08	78	1.80	46	1/4 NPT	0.66	0.30
¾	20	4.13	105	2.15	55	3/8 NPT	1.21	0.55
1	25	4.84	123	2.81	71	3/8 NPT	1.88	0.86
1¼	32	5.64	143	3.26	83	3/4 NPT	3.10	1.41
1½	40	6.23	158	3.64	93	3/4 NPT	4.64	2.10
2	50	7.75	197	5.02	128	1 NPT	7.48	3.39

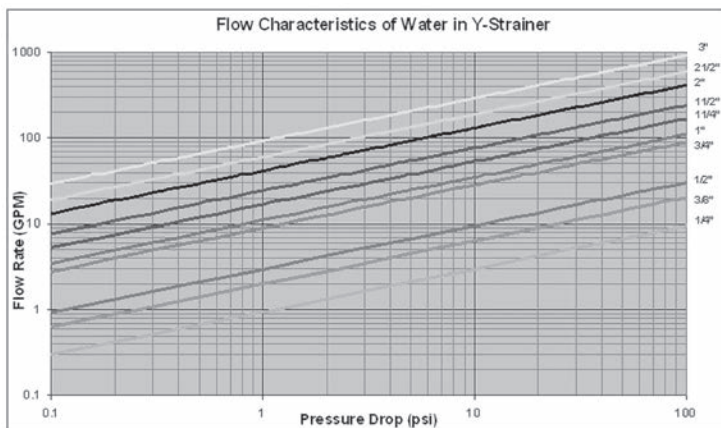

**WARNING:** This product can expose you to chemicals including lead, which is known to the State of California to cause cancer and birth defects or other reproductive harm. For more information go to [www.P65Warnings.ca.gov](http://www.P65Warnings.ca.gov).



**PF-221/222-A**

Press x Press  
Female End

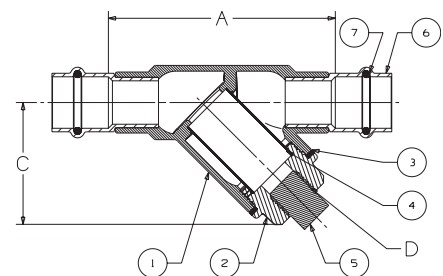

**PF-221/222-A**  
P x P



**PF-221/222-B**

Press x Press  
Female End

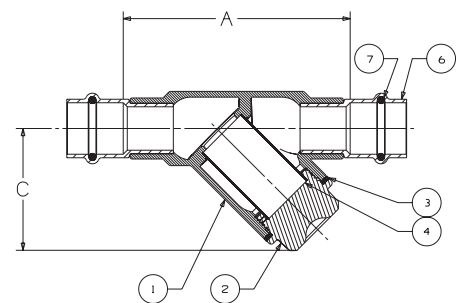

**PF-221/222-B**  
P x P

Visit our website for the most current information.

# NIBCO® Press System Ball Valve Handle Options

A wide variety of handles are available to fulfill safety and operation requirements in various processing and manufacturing industries. The lever handle with plastic cover is standard. Other handle options are shown. Stainless steel lever handles are available, as an option, also with plastic covers. If an optional handle is desired, please indicate which one when ordering. Many of these options are field assembly only.

 <p><b>CS Standard Lever Handle</b></p>	 <p><b>CS Extended Lever Handle with Memory Stop</b> Allows for 2" of Insulation</p>	 <p><b>NIB-SEAL® Handle</b> Allows for 2" of Insulation</p>
 <p><b>CS Locking Lever Handle</b></p>	 <p><b>CS Round Handle</b></p>	 <p><b>NIB-SEAL® Locking Extended Handle</b></p>
 <p><b>SS Standard Lever Handle</b></p>	 <p><b>CS Extended Round Handle</b> Allows for 2" of Insulation</p>	 <p><b>Vertical Chain Lever</b></p>
 <p><b>SS Locking Lever Handle</b></p>	 <p><b>CS Wing Handle</b></p>	 <p><b>Horizontal Chain Lever</b></p>
 <p><b>CS Extended Lever Handle</b> Allows for 2" of Insulation</p>	 <p><b>Seat and Seal Kit</b></p>	 <p><b>Memory Stop Kit</b></p>

Visit our website for the most current information.

# NIBCO® Press System Bronze Ball Valves

## NIB-SEAL® Technical Data

**NIBCO bronze ball valves installed with NIB-SEAL insulated handles are the only approach that keeps your insulated piping system completely intact.**

The revolutionary NIB-SEAL bronze ball valve stops condensate cold. Its unique thermal barrier design keeps moisture from infiltrating your insulated system while preventing thermal energy loss through exposed metal handles.

Designed for new installations or retrofitting existing systems, NIB-SEAL bronze ball valves offer a wide range of advantages for typical commercial HVAC systems as well as industrial applications where insulated piping is desirable.

- Protective sleeve provides a stationary surface to affix the insulation, allowing operation and maintenance of the valve without destroying the integrity of the insulated system.
- High-strength cylindrical handle design features easy access to standard adjustable memory stop for system balancing. The valve packing is also readily accessible for routine maintenance.
- Cap and insulating plug provide a vapor seal to prevent exchange of air to maximize the efficiency of your insulated piping system.
- Position indicators allow at-a-glance determination of whether valve is in open or closed position.
- Pre-formed hole allows for convenient tagging.

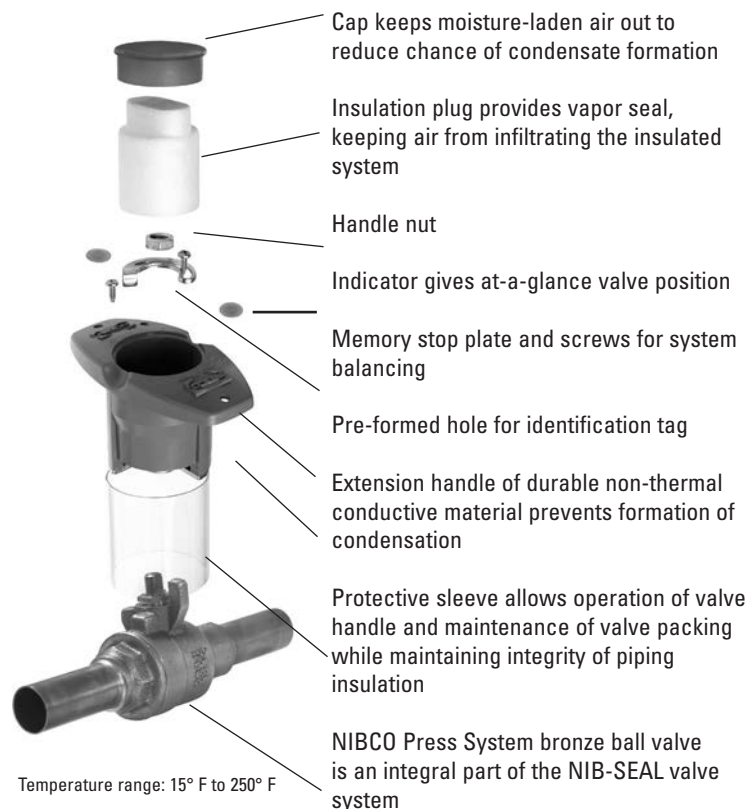

US PATENT 5,236,006

Visit our website for the most current information.

# NIB-SEAL® Locking Handle

U.S. PATENT 9,810,344

The patented technology of the 3-in-1 NIB-SEAL locking handle solves three problems at once: **it extends, it insulates, and it locks**. The innovative locking handle design extends valve actuation to provide ample room for insulating around piping systems, and its unique thermal barrier system prevents heat transfer and condensate development. The NIB-SEAL locking handle also allows the valve to be locked in the full open or closed position to prevent incidental actuation.

Designed for new installations, the NIB-SEAL locking handle is engineered to work with NIBCO® bronze ball valves.\*\*

**Applications:** For piping systems requiring up to 2" of insulation, specify a non-conductive CPVC extended-locking handle bronze ball valve tested to UL 2043, and UL listed for installation in air handling spaces. The assembly offers a vapor seal, position indicators, locking device, and actuation without disturbing the insulation. Designed for new installations, the NIB-SEAL locking handle installed on bronze ball valves offers a wide range of advantages for typical commercial HVAC systems as well as industrial applications where insulated piping with a locking device is desirable. Specify NIB-SEAL insulated locking handle.

**Approvals:** UL 2043

**Safety Lock Compatibility:** Cable lock as small as 1/8" diameter to padlock as big as 0.33" diameter shackle.

**Temperature Range:** 15° F to 250° F

Not intended for steam applications in excess of 15 psi.

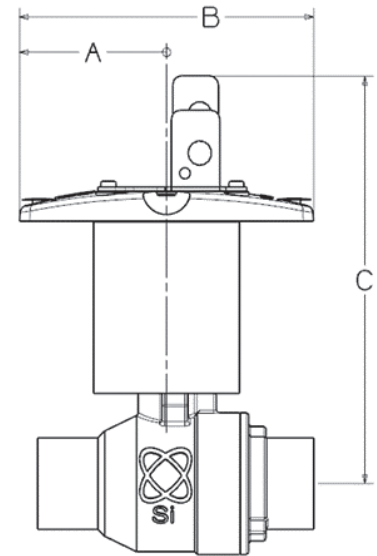

## Dimensions

Series 585						
Sizes	A		B		C	
	In.	mm.	In.	mm.	In.	mm.
1/4"	2.19	55.63	4.25	107.95	5.30	134.62
3/8"	2.19	55.63	4.25	107.95	5.30	134.62
1/2"	2.19	55.63	4.25	107.95	5.42	137.67
3/4"	2.19	55.63	4.25	107.95	5.69	144.53
1"	2.19	55.63	4.25	107.95	5.88	149.35
1 1/4"	3.38	85.85	6.50	165.10	6.84	173.74
1 1/2"	3.38	85.85	6.50	165.10	7.06	179.323
2"	3.38	85.85	6.50	165.10	7.30	185.42

Series 595						
Sizes	A		B		C	
	In.	mm.	In.	mm.	In.	mm.
1/4"	2.19	55.63	4.25	107.95	5.20	132.08
3/8"	2.19	55.63	4.25	107.95	5.20	132.08
1/2"	2.19	55.63	4.25	107.95	5.20	132.08
3/4"	2.19	55.63	4.25	107.95	5.47	138.94
1"	2.19	55.63	4.25	107.95	5.66	143.76
1 1/4"	3.38	85.85	6.50	165.10	6.62	168.15
1 1/2"	3.38	85.85	6.50	165.10	6.84	173.74
2"	3.38	85.85	6.50	165.10	7.08	179.83

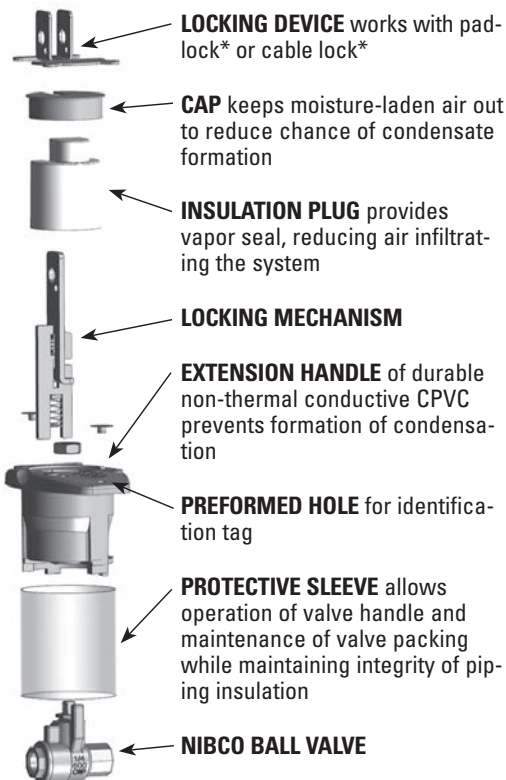

\* Padlock and cable lock not included

\*\* Valve type showing above is just for handle representation

Visit our website for the most current information.

Factory installed only.

Order appropriate factory installed NIBCO valve figure number with suffix "LX". Example: T-585-70-LX, 1/2"

NIB-SEAL on solder/sweat ball valves are shipped unassembled.

# Butterfly Valve Options and Accessories

## Lever-Lock Operator (Standard)

PFD2000

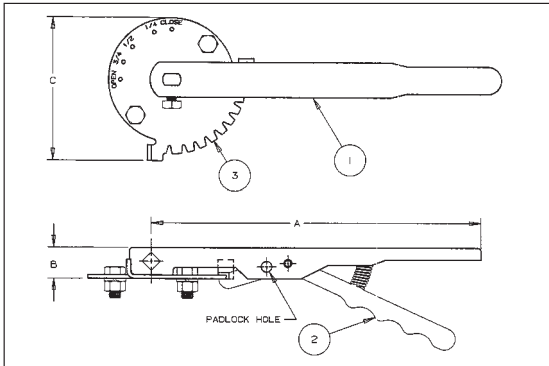

The lever-lock handle and throttling plate provide throttling notches every 10° for excellent manual control in balancing up to 90° or shut off service. The valve may be padlocked in any one of the positions including opened or closed by virtue of a locking hole located in the handle and lever.

## Position-Lock Operator (Optional)

PFD2000

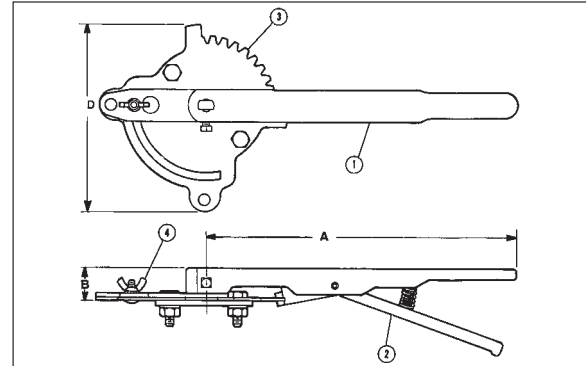

The position-lock can be used to set the valve in any position or as a memory stop so the valve may be reopened to the previous position. The valve may be padlocked in full open or full closed position.

Ordering: Sold as a field retrofitable kit only.

### MATERIAL LIST

PART	SPECIFICATION
1. Handle	Polymer Coated Iron
2. Lever-Lock	Zinc Plated Steel
3. Throttle Plate	Zinc Plated Steel

### DIMENSIONS AND TORQUE OUTPUT

PFD Lever Size	Lever (STD)	Throttle Plate/ (STD)	Infinite Pos. Kit	Dimensions				Torque Rated Output in Inch-Pounds	
				A	B	C	D	At 60 pounds Pull	At 100 pounds Pull
2½"-3"	T115107PP	T115138PP	T114841FG	10½	1	4/8	6¾	540 In-Lbs.	900 In-Lbs.
4	T115108PP	T115138PP	T114842FG	10½	1	4/8	6¾	540 In-Lbs.	900 In-Lbs.

## Gear Operator options and accessories (2 1/2" through 4" 2000 series only)

2" Square Operating Nut

Memory Stop

Flag Indicator

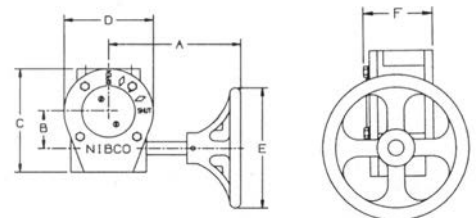
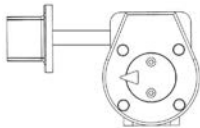

Consult factory for: square operating nut, memory stop and flag indicator

## Cast Iron Gear Operator

The NIBCO® butterfly valve can be provided with heavy-duty operator and indicator. Recommended for valves 8" and larger, for trouble-free operation in all moisture and weather conditions (not submersible). Operator is a self-locking worm gear type. Equipped with adjustable stops at open and shut positions. Ordering: Specify by adding (-5) to Fig. No., i.e., PFD2000-5. Babbit sprocket may be added to handwheel. See below for sizing information.

Available options: memory stop gear operator kit, 2" square operating nut, flag indicator and handwheel for GO.

GEAR OPERATOR DETAIL FOR SIZES 2 1/2" TO 4" (PFD2000 ONLY)										GEAR OPERATOR ACCESSORIES & REPLACEMENT PARTS					
PFD VALVE	GEAR OPERATOR NUMBER	RATIO	GEAR OP WEIGHT	DIMENSIONS (INCHES)						STEM ADAPTER BUSHING	SPROCKET RIM MODEL	SQUARE OPERATING NUT	FLAG INDICATOR	MEMORY STOP KIT	REPLACEMENT HANDWHEEL
				A	B	C	D	E	F						
2½ - 3	T117118PP	24:1	10	7.64	1.77	5.04	4.24	5.91	2.79	T046653PP	#1½	T117792FC	T116682PP	T026196PP	T117122PP
4	T117118PP	24:1	10	7.64	1.77	5.04	4.24	5.91	2.79	T046654PP	#1½	T117792FC	T116682PP	T026196PP	T117122PP

- NOTE:**
1. Stem adapter bushing must be ordered separately when needed for smaller size valves.
  2. All other accessories must be ordered separately. (Sprocket rim, square operator nut, flag indicator & memory stop kit.)
  3. Gear operator comes with handwheel.

Visit our website for the most current information.

# Butterfly Valve Technical Information

**Table 4** Recommended Bolt Lengths

VALVE SIZE 1000/2000/3000 SERIES ONLY	TOTAL VALVE BODY WIDTH	ANSI B16.1 CLASS 125 CAST IRON FLANGE THICKNESS	ANSI B16.5 CLASS 150 STEEL FLANGE THICKNESS	ANSI B16.47 (SERIES A) CLASS 150 STEEL MSS SP-44 FLANGE THICKNESS	ANSI B16.47 (SERIES B) CLASS 150 STEEL WELD NECK FLANGE THICKNESS	ANSI B16.47 (SERIES B) CLASS 150 STEEL BLIND STYLE FLANGE THICKNESS	RECOMMENDED CAP SCREW LENGTH (LUGGED VALVES) (C)	TOTAL QUANTITY CAP SCREWS/BOLTS (TO MOUNT 2 FLANGES)	CAP SCREW SIZE
2 1/2"	1.81	0.69	—	—	—	—	1.50	8/4	5/8-11 UNC
		—	0.88	—	—	—	1.75	8/4	
3"	1.81	0.75	—	—	—	—	1.50	8/4	5/8-11 UNC
		—	0.94	—	—	—	1.75	8/4	
4"	2.06	0.94	0.94	—	—	—	1.75	16/8	5/8-11 UNC

Bolt Tightening  
Cross Over Pattern

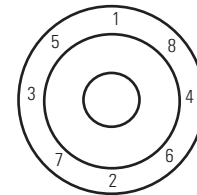

**Fig. 1**

## Resilient Liner Materials

**EPDM** – EPDM is a terpolymer elastomer made from ethylene-propylene diene monomer. EPDM has good abrasion and tear resistance and offers excellent chemical resistance to a variety of acids and alkalines. It is susceptible to attack by oils and is not recommended for applications involving petroleum oils, strong acids or strong alkalines. EPDM should not be used on compressed air lines. It has exceptionally good weather aging and ozone resistance. It is fairly good in ketones and alcohols.

### Liner Temperature Ratings

Liner Material	Temperature
EPDM**	-20°F to + 250°F

\*\* EPDM is rated at 250°F intermittent service and 225°F continuous service.

Proprietary compound formulas are used for each of the elastomers to provide the right combination of seat compression, abrasion resistance and chemical resistance to match your application. Elastomeric seat materials are not suitable for steam service.

# **NIBCO**<sup>®</sup> **press**system Tools, Jaws & Chains



*Visit our website for the most current information.*

# NIBCO® Press System Tools

## PC-280 32kN

1/2" through 4"



### MATERIAL LIST

MODEL NO.	DESCRIPTION	LBS.
PC-280	32kN pressing Tool with 2 - 18V, 3.0 Ah Lithium-ion batteries, 110V battery charger & case	25.40
PC-10S	1/2" Standard Pressing Jaw (for 32kN PC-100 or PC-280)	4.14
PC-11S	3/4" Standard Pressing Jaw (for 32kN PC-100 or PC-280)	4.18
PC-12S	1" Standard Pressing Jaw (for 32kN PC-100 or PC-280)	4.52
PC-13S	1 1/4" Standard Pressing Jaw (for 32kN PC-100 or PC-280)	4.30
PC-14S	1 1/2" Standard Pressing Jaw (for 32kN PC-100 or PC-280)	9.61
PC-15S	2" Standard Pressing Jaw (for 32kN PC-100 or PC-280)	9.26
PC-16S	1/2"-1 1/4" (4 jaws) Standard Press Jaw Kit w/Case (for 32kN PC-100 or PC-280)	25.25
PC-17S	1 1/2"-2" (2 jaws) Standard Press Jaw Kit w/Case (for 32kN PC-100 or PC-280)	23.76
PC-2	2 1/2" Pressing Chain w/Case (for 32kN PC-100 or PC-280)	18.58
PC-3	3" Pressing Chain w/Case (for 32kN PC-100 or PC-280)	19.40
PC-4	4" Pressing Chain w/Case (for 32kN PC-100 or PC-280)	23.81
PC-234	2 1/2", 3" & 4" Pressing Chain Kit (for 32kN PC-100 or PC-280)	44.42
PC-5	PC-5 Pressing Chain Adapter Jaw (note: must be used with 2 1/2", 3" & 4" chains)	7.01
PC-7L	18V, 3.0Ah Lithium-ion Battery (for 32kN PC-280 or 15kN PC-20M)	1.30
PC-8L	110V Battery Charger (for PC-4ML or PC-7L)	2.20
PC-9L	AC Adapter (for 32kN PC-280 or 15kN PC-20M)	1.70
PC-280C	Plastic Replacement Case for 32kN PC-280 Tool	7.50
PC-2C	Metal Replacement Case for PC-2 or PC-3 Chain	8.10
PC-4C	Metal Replacement Case for PC-4 Chain	8.10
PC-234C	Plastic Replacement Case for PC-234 Chain Kit	7.72
PC-16SC	Metal Replacement Case for PC-16S (1/2" - 1 1/4" Jaws)	8.10
PC-17SC	Metal Replacement Case for PC-17S (1 1/2" - 2" Jaws)	4.40
PC-51	1/2" - 2" Deburring Tool	0.92



**PC-10S thru PC-15S**

Standard Pressing Jaws

**PC-280 32kN**

Pressing Tool



**PC-2 thru PC-4**

Pressing Chains



**PC-5**

Pressing Chain Adapter Jaw



**PC-7L**

18V, 3.0 Ah  
Lithium-ion Battery



**PC-8L**

110V Battery Charger



**PC-51**

1/2" - 2" Deburring Tool



**PC-9L**

AC Adapter

**WARNING:** This product can expose you to chemicals including lead, which is known to the State of California to cause cancer and birth defects or other reproductive harm. For more information go to [www.P65Warnings.ca.gov](http://www.P65Warnings.ca.gov).

Visit our website for the most current information.

# NIBCO® Press System Tools

## PC-20M 15kN

1/2" through 1"

### MATERIAL LIST

MODEL NO.	DESCRIPTION	LBS.
PC-20M	15kN Mini Pressing Tool, 2 - 18V, 2.0 Ah Lithium-ion batteries, 110V charger & case (NO jaws)	10.42
PC-200M	15kN Mini Pressing Tool, 3 Jaws, 2 - 18V, 2.0 Ah Lithium-ion batteries, 110V charger & case	17.47
PC-1M	1/2" Jaw (for 15kN Mini Pressing Tool - PC-10M or PC-20M)	2.09
PC-2M	3/4" Jaw (for 15kN Mini Pressing Tool - PC-10M or PC-20M)	2.05
PC-3M	1" Jaw (for 15kN Mini Pressing Tool - PC-10M or PC-20M)	2.07
PC-4ML	18V, 2.0Ah Lithium-ion Battery (for 15kN PC-20M)	0.85
PC-7L	18V, 3.0Ah Lithium-ion Battery (for 32kN PC-280 or 15kN PC-20M)	1.30
PC-8L	110V Battery Charger (for PC-4ML and PC-7L)	2.20
PC-9L	AC Adapter (for 32kN PC-280 or 15kN PC-20M)	1.70
PC-20MC	Plastic Replacement Case for PC-10M & PC-20M	4.00
PC-50	1/2" - 1" Deburring Tool	0.42



**PC-20M**  
15kN Mini Pressing Tool



**PC-200M**  
15kN Mini Pressing Tool with  
1/2", 3/4" and 1" Jaws



**PC-1M, 2M, 3M**  
Mini Pressing Jaws



**PC-4ML**  
18V, 2.0 Ah  
Lithium-ion Battery



**PC-8L**  
110V Battery Charger



**PC-50**  
1/2" - 1" Deburring Tool



**PC-7L**  
18V, 3.0 Ah  
Lithium-ion Battery



**PC-9L**  
AC Adapter

**WARNING:** This product can expose you to chemicals including lead, which is known to the State of California to cause cancer and birth defects or other reproductive harm. For more information go to [www.P65Warnings.ca.gov](http://www.P65Warnings.ca.gov).

Visit our website for the most current information.

# NIBCO® Press System Tools

## 32KN PC-280 & 15KN PC-20M FEATURES

### TOOLS

#### Light weight

15kN PC-20M Mini: 3.7 lbs. (without jaw)  
32kN PC-280: 9.4 lbs. (without jaw)

#### Easy to handle / simple design

Jaws rotate 350°  
No calibration necessary  
No complicated switches or controls  
Mini: Ergonomic compact design is easy to use in tight spaces

#### Interruptible crimp cycle

Safety feature prevents injuries  
Can begin crimp, stop to align and level fitting / tube, and complete crimp

#### Battery

Can be changed during crimp cycle  
Lithium-ion has short charging cycle and larger capacity

- PC-4ML: 15 minute recharge time
- PC-7L: 22 minute recharge time

#### AC Power Adapter

Converts the tool to electric power  
Allows continuous use

#### Service light

Illuminates at 10,000 cycles  
Tool will not stop operating when light illuminates

- RED indicates battery charge status, service intervals, tool functions & faults
- WHITE illuminates the work area

#### Hydraulic Pressure Check (HPC)

An audible warning signal sounds if adequate working pressure is not achieved

## PRESSING CHAINS (2 1/2" to 4" ONLY)

#### Uniform crimp

Maintains proper pipe alignment

#### Easy to install and remove

Once secured to fitting, chain cannot fall off prior to crimp  
Chain easily removed post crimp

#### Crimp Identification

Easy to identify crimp has been made from a distance

## PC-100 and PC-10M Accessories

### MATERIAL LIST

MODEL NO.	DESCRIPTION	LBS.
PC-7	12V, NiMH Battery - 3.0Ah for PC-100	1.57
PC-8L	110V Battery Charger (for PC-4ML and PC-7L)	2.20
PC-4M	1.3 Ah NiCd 9.6V Battery for 15kN Mini Pressing Tool	0.85
PC-5M	120V Charger for 15kN Mini Pressing Tool	1.13
PC-100C	Metal Case for PC-100 Tool	14.30



**PC-4M**

9.6V, 1.3 Ah  
NiCd Battery



**PC-7**

12V, 3.0 Ah  
NiMH Battery



**PC-8L**

120V Battery Charger

Visit our website for the most current information.

# NIBCO® Press System Approved Tool and Jaw Compatibility Matrix

Pressing tool, jaw and chain sets are an integral part of ensuring a reliable, permanent connection between NIBCO Press System fittings, valves and copper piping.

**Only use pressing tools, jaws and chain sets that have been tested and approved for use with NIBCO Press System fittings and valves.**

The following table details compatibility of **approved** pressing tools, chains and jaws with the NIBCO Press System fittings and valves:

	1/2" - 1" NIBCO® Press System Pressing Jaws (PC-1M, PC-2M, PC-M3)	1/2" - 1 1/4" Milwaukee® M12™ Pressing Jaws	1/2" & 3/4" RIDGID® ProPress® Compact Pressing Jaws	1/2" - 1" RIDGID® ProPress® Compact Pressing Jaws	1/2" - 1 1/4" RIDGID® ProPress® C1 Compact Kit (C1 Actuator & Press Rings)	Rothenberger Compact Pressing Jaws	Stanley® VIRAX® Press Inserts	DEWALT® DCE200 Standard Press Tool Jaws	1/2" - 2" NIBCO® Press System Standard Pressing Jaws (PC-10S, PC-11S, PC-12S, PC-13S, PC-14S, PC-15S)	DEWALT® DCE210 Compact Press Tool Jaws	1/2" - 2" Milwaukee® M18™ Press System Standard Pressing Jaws	1/2" - 2" RIDGID® ProPress® Press System Standard Pressing Jaws	1/2" - 2" RIDGID® ProPress® V1 & V2 Standard Kits (Actuator & Press Rings)	1/2" - 2" DEWALT® DCE200 Press System Standard Pressing Jaws	1/2" - 2" REMS® Press System Standard Pressing Jaws	1/2" - 2" Rothenberger® Press System Standard Pressing Jaws	DEWALT® DCE200 Standard Press Tool Jaws	1/2" - 2" Stanley® VIRAX® Press System Standard Pressing Jaws	2 1/2" - 4" NIBCO® Pressing Chains (PC-5 Adaptor & PC-2, PC-3, PC-4 Chains)	Milwaukee Tool 2 1/2" - 4" NIBCO press rings and adapter	
	1/2" - 1 1/4"						1/2" - 2"										2 1/2" - 4"				
SIZE	1/2" - 1 1/4"						1/2" - 2"										2 1/2" - 4"				
Compact Pressing Tools	NIBCO® PC-10M 15kn Mini	YES	—	—	—	—	YES	—	—	—	—	—	—	—	—	—	—	—	—	—	—
	NIBCO® PC-20M 15kn Mini	YES	—	—	—	—	YES	—	—	—	—	—	—	—	—	—	—	—	—	—	—
	Milwaukee® M12™	—	YES	—	—	—	—	—	—	—	—	—	—	—	—	—	—	—	—	—	—
	RIDGID® RP 115	—	—	YES	—	—	—	—	—	—	—	—	—	—	—	—	—	—	—	—	—
	RIDGID® 100-B Compact	—	—	—	YES	YES	—	—	—	—	—	—	—	—	—	—	—	—	—	—	—
	RIDGID® RP200-B Compact	—	—	—	YES	YES	—	—	—	—	—	—	—	—	—	—	—	—	—	—	—
	RIDGID® RP210-B Compact	—	—	—	YES	YES	—	—	—	—	—	—	—	—	—	—	—	—	—	—	—
	RIDGID® RP240 Compact	—	—	—	YES	YES	—	—	—	—	—	—	—	—	—	—	—	—	—	—	—
	RIDGID® RP241 Compact	—	—	—	YES	YES	—	—	—	—	—	—	—	—	—	—	—	—	—	—	—
	Rothenberger® Compact	YES	—	—	—	—	YES	—	—	—	—	—	—	—	—	—	—	—	—	—	—
Standard Pressing Tools	Stanley® VIRAX® M20+ Compact	—	—	—	—	—	YES	—	—	—	—	—	—	—	—	—	—	—	—	—	—
	DEWALT® DCE210	—	—	—	—	—	—	YES	—	—	—	—	—	—	—	—	—	—	—	—	—
	NIBCO® 32kN PC-100	—	—	—	—	—	—	—	YES	—	YES	YES	YES	YES	YES	YES	—	YES	YES	—	—
	NIBCO® 32kN PC-280	—	—	—	—	—	—	—	YES	—	YES	YES	YES	YES	YES	YES	—	YES	YES	—	—
	Milwaukee® M18™ Force Logic™	—	—	—	—	—	—	—	YES	—	YES	—	—	—	—	—	—	—	—	—	—
	Milwaukee® M18™ Force Logic™ (Long Throw)	—	—	—	—	—	—	—	YES	—	YES	—	—	—	—	—	—	—	—	—	YES
	RIDGID® CT 400	—	—	—	—	—	—	—	YES	—	—	YES	YES	—	—	—	—	—	—	—	—
	RIDGID® RP 320-E	—	—	—	—	—	—	—	YES	—	—	YES	YES	—	—	—	—	—	—	—	—
	RIDGID® RP 330-B	—	—	—	—	—	—	—	YES	—	—	YES	YES	—	—	—	—	—	—	—	—
	RIDGID® RP 330-C	—	—	—	—	—	—	—	YES	—	—	YES	YES	—	—	—	—	—	—	—	—
	RIDGID® RP 340	—	—	—	—	—	—	—	YES	—	—	YES	YES	—	—	—	—	—	—	—	—
	RIDGID® RP 342 XL	—	—	—	—	—	—	—	YES	—	—	YES	YES	—	—	—	—	—	—	—	—
	RIDGID® RP 350	—	—	—	—	—	—	—	YES	—	—	YES	YES	—	—	—	—	—	—	—	—
	RIDGID® RP 351	—	—	—	—	—	—	—	YES	—	—	YES	YES	—	—	—	—	—	—	—	—
	DEWALT® DCE200	—	—	—	—	—	—	—	YES	—	—	—	—	—	—	—	—	—	—	—	—
	REMS® Akku-Press	—	—	—	—	—	—	—	—	—	—	—	—	—	YES	—	—	—	—	—	—
	REMS® Power-Press	—	—	—	—	—	—	—	—	—	—	—	—	—	—	YES	—	—	—	—	—
	Rothenberger® ROMAX® Pressliner	—	—	—	—	—	—	—	—	—	—	—	—	—	—	—	YES	YES	—	—	—
Rothenberger® ROMAX® AC ECO	—	—	—	—	—	—	—	—	—	—	—	—	—	—	—	—	YES	—	—	—	
Stanley® VIRAX® P20+	—	—	—	—	—	—	—	—	—	—	—	—	—	—	—	—	—	YES	—	—	
DEWALT® DCE200	—	—	—	—	—	—	—	—	—	—	—	—	—	—	—	—	YES	—	—	—	

For the latest listing of approved pressing tool, jaw and chain combinations, visit [nibco.com](http://nibco.com). NIBCO recommends minor tool service performed once per year and major service every three years. For technical or service assistance, contact NIBCO Technical Services 1-888-446-4226.

RIDGID® is a registered trademark of RIDGID, Inc.

ProPress® is a registered trademark of Viega GmbH & Co

ROMAX® is a registered trademark of ROTHENBERGER

VIRAX® is a registered trademark of Stanley Works

Milwaukee® is a registered trademark of Milwaukee Electric Tool Corporation

FORCE LOGIC™ is a registered trademark of Milwaukee Electric Tool Corporation

DEWALT® is a registered trademark of The Black & Decker Corporation

**CAUTION:**

- NIBCO press fittings and valves (2 1/2", 3", 4" ends) to be installed ONLY with NIBCO pressing tools & chains.
- Webstone press valves and fittings (2 1/2", 3", 4" ends) to be installed ONLY with XLC pressing tools & jaws.

Visit our website for the most current information.

**NIBCO**<sup>®</sup>  
**press**system  
Engineering Data

*Visit our website for the most current information.*

# NIBCO® Press System — Engineering Data

## Copper and Copper Alloy Fittings

### Standards

O-ring seal joints are not new to the piping industry, but joining techniques like the NIBCO Press System are providing new alternatives for copper piping assembly. NIBCO has relied on its century of experience in copper and brass piping products to design the best performing and most dependable line of fittings possible.

### Applications

The NIBCO Press System fittings are designed to join with ASTM B 88 seamless copper water tube in hard drawn/half-hard condition, Type K, L, and M; as well as, with annealed tubing in 1/2", 3/4" and 1" sizes for residential and commercial potable, hot, chilled and process water applications for plumbing and HVAC systems. Copper and copper alloy materials and EPDM elastomeric seals have a long history of compatibility with common chemicals used in these systems. A chemical resistance chart should always be referenced when other fluids are to be introduced.

**NOTE: FLUIDS CONTAINING HYDROCARBON-BASED OILS ARE NOT COMPATIBLE WITH THE EPDM SEAL.**

### Pressure/Temperature Limitations

-20°F to 250°F up to 200 psig, non-shock working pressure except where otherwise noted.

### Materials:

- Wrot Copper
  - ASTM B 75 Alloy C12200
- Cast Copper Alloy
  - ASTM B584 Alloy C87600 and C84400
- Elastomeric Seals
  - EPDM O-rings compliant with IAPMO Z1117 and ASME B16.51

NIBCO® press fittings meet all performance requirements of ASME B16.51

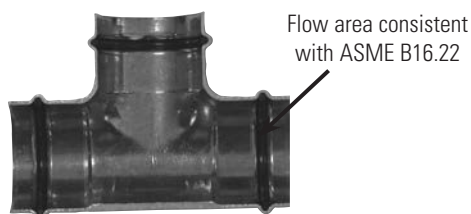

**NOTE: Freezing weather precaution — subsequent to testing a piping system, valve should be in an open position to allow complete drainage.**

### Thermal Expansion and Contraction

Thermal expansion and contraction should be accounted for in all system designs. Further guidance on how to account for these stresses can be found in The Copper Development Association's Copper Tube Handbook, Section 3.

### Performance

The following performance tests were conducted per ASME B16.51. The fitting dimensions, materials of construction and performance tests were witnessed and verified by internationally recognized NSF. A letter of verification is available upon request:

1. Dimensional Verification
  - a. Inside diameter of press cup and waterway
  - b. Outside diameter of press cup and waterway
  - c. Wall thickness
  - d. Threaded ends conformance to ASME B1.20.1
2. Hydrostatic Minimum Burst Strength Pressure
  - a. Fitting samples hydrostatically tested to a minimum of 600 psi (three times the rated internal working pressure) at 73°F.
3. Unrestrained Hydrostatic Pressure Test at 68°F (20°C) and 200°F (93°C)
  - a. Fitting assemblies were filled with water and pressurized to 600 psiG at 68° and 200°F for 48 hours.
4. Static Torque
  - a. Fittings were filled with water, had a minimum torque applied and released. Each fitting was then pressurized to 400 psiG for 48 hours.
5. Bending Test
  - a. A sample fitting was installed between two equal lengths of hard-drawn copper tubing supported six (6) feet apart. A concentrated load was applied to the center of the fitting. The 1/2" thru 2" assemblies were subjected to 600 psiG water pressure and 2-1/2" thru 4" were subjected to 400 psi water pressure for one (1) hour at 68°F (20°C).
6. Vacuum Pressure Test
  - a. Fittings were subjected to a vacuum pressure of 24.5 inches of mercury for one (1) hour at 68°F (20°C).
7. Cyclic Pressure Test
  - a. Fittings were subjected to a hydraulic shock pressure of 400 psiG for 10,000 cycles.
8. Vibration Test
  - a. Fitting assemblies were subjected to a hydrostatic cyclic vibration test at 400 psiG and 2-1/2" thru 4" were subjected to 400 psi water pressure for 1,000,000 cycles. After cycling, the 1/2" thru 2" assemblies were pressurized to 600 psiG for 30 minutes and 2-1/2" thru 4" were pressurized to 400 psi for 48 hours.
9. Thermocycling Test
  - a. Test assemblies were constructed using type L copper tube and press connect fittings. The test assemblies were subjected to flowing water at 145 psi cycled between 68°F (20°C) and 200°F (93°C) for a period of 15 minutes at each temperature for nominal size 2" and smaller. Nominal size 2 1/2" and larger were pressurized with air and immersed in water at 68°F (20°C) and 200°F (93°C). Cycling continued for 5,000 cycles for sizes 2" and smaller and 2,500 cycles for 2 1/2" and larger size fittings.
10. Dynamic Torque at 68°F (20°C) and 200°F (93°C)
  - a. Fittings were assembled between two lengths of hard-drawn copper tubing. With one tube fixed, the other tube twisted ±5° for 10,000 cycles at 68°F (20°C) or 200°F (93°C). Each assembly was then subjected to 400 psiG water pressure at 68°F (20°C) or 200°F (93°C) for 1 hour.

Tests were performed with K and M hard drawn tubing. The thermocycle test used L hard drawn tube.

Visit our website for the most current information.

# NIBCO<sup>®</sup> Press System — Sample Specification

## FITTINGS

### 2" and Smaller:

Fittings shall comply with NSF 61, CSA, UPC and be approved by the local jurisdiction. The NIBCO Press System may be used at the contractor's option for the following building services piping - 20°F to +250°F up to 200 psi:

- **Hot and Cold Domestic Water**
- **Potable Water**
- **Condenser and Chilled Water Service**
- **Hot Water Heating Service**

Wrot copper press fittings shall be made from commercially pure copper mill products per ASTM B 75 Alloy C12200. Cast copper alloy press fittings shall be made from materials with a minimum of 78% copper and a maximum of 15% zinc. The press fittings connections shall be compatible with seamless K, L or M copper tube made to ASTM B 88 as well as 1/2", 3/4" and 1" annealed copper tubing. Fittings shall have a maximum non-shock working pressure of 200 psi between the temperatures of -20°F and +250°F. Elastomeric seals shall be made of EPDM material, and the fittings shall be manufactured with an inboard bead design. All fittings shall be installed in accordance with the manufacturer's installation instructions and according to local plumbing and mechanical codes. The press-to-connect joint shall be made with pressing tools and jaw sets recommended and authorized by NIBCO.

### 2½" through 4":

Fittings shall comply with NSF 61, CSA, UPC and be approved by the local jurisdiction. The NIBCO Press System may be used at the contractor's option for the following building services piping - 20°F to +200°F up to 200 psi:

- **Hot and Cold Domestic Water**
- **Potable Water**
- **Condenser and Chilled Water Service**
- **Hot Water Heating Service**

Wrot copper press fittings shall be made from commercially pure copper mill products per ASTM B 75 Alloy C12200. Cast copper alloy press fittings shall be made from materials with a minimum of 78% copper and a maximum of 15% zinc. The press fittings connections shall be compatible with seamless K, L or M copper tube made to ASTM B 88. Fittings shall have a maximum non-shock working pressure of 200 psi between the temperatures of -20°F and +250°F. Elastomeric seals shall be made of EPDM material, and the fittings shall be manufactured with an inboard bead design. All fittings shall be installed in accordance with the manufacturer's installation instructions and according to local plumbing and mechanical codes. The press-to-connect joint shall be made with pressing tools and jaw sets recommended and authorized by NIBCO.

Visit our website for the most current information.

# NIBCO® Press System — Sample Specification

## VALVES

### 2" and Smaller Ball Valves: (on/off, isolation or throttling)

Ball valves with male or female press-to-connect ends shall be rated at 200 psi CWP to +250°F maximum. Valves shall be manufactured in accordance with MSS SP-110 and constructed of dezincification resistant cast bronze bodies. No brass containing more than 15% zinc shall be approved. Valve shall have reinforced PTFE seats, blow-out proof stem, full-port ball, chrome/nickel plated ball or 316 SS ball for aggressive water conditions. Where piping is to be insulated, ball valves shall be equipped with 2" extended handles of non-thermal conductive material. Handle to have extended sleeve incorporating an insulation plug to provide a vapor barrier and allow valve operation without disturbing the insulation, and a memory stop, which can be set after installation.

#### Acceptable Valves: (non-insulated lines):

NIBCO® PC585-70, PF585-70 or PS585-70  
(chrome/nickel plated ball)  
NIBCO® PC585-70-66, PF585-70-66, PS585-70-66 or PCM585-60  
(316 SS ball)

#### Acceptable Valves: (insulated lines):

NIBCO® PC585-70-NS, PF585-70-NS or PS585-70-NS  
(chrome/nickel plated ball)  
NIBCO® PC585-70-66-NS, PF585-70-66-NS or PCM585-60-NS  
(316 SS ball)

(Note to Specifier: Include press gate valves in addition/in lieu of press ball valves for ON/OFF and isolation services if requested or required.)

### 2" and Smaller Gate Valves: (On/Off and Isolation)

Gate valves with male or female press-to-connect ends shall be rated to 200 psi CWP at +250°F maximum. Valves shall be manufactured in accordance with MSS SP-80. Valve body, bonnet and wedge to be manufactured of dezincification resistant cast bronze (ASTM B 62). Stems shall be of silicon bronze (ASTM B 371) or low zinc alloy (ASTM B 99). Non-asbestos packing and malleable or ductile iron hand-wheel shall be standard.

#### Acceptable Valves:

NIBCO® PF111 or PS111 - rising stem gate valve  
NIBCO® PF113 or PS113 - non-rising stem gate valve

### 2" and Smaller Globe and Angle Valves: (Throttling Service)

Globe and angle valves with male or female press-to-connect ends shall be rated to 200 psi CWP at +250°F maximum. Valves shall be manufactured in accordance with MSS SP-80. Valve body, bonnet and wedge to be manufactured of dezincification resistant cast bronze (ASTM B 62). Stems shall be of silicon bronze (ASTM B 371) or low zinc alloy (ASTM B 99). Non-asbestos packing and malleable or ductile iron hand-wheel shall be standard.

#### Acceptable Valves:

NIBCO® PF211-Y or PS211-Y - globe valve  
NIBCO® PF311-Y or PS311-Y - angle valve

### 2" and Smaller Check Valves: (Back Flow Prevention)

Check valves (Y pattern, swing type or in-line) with male or female press-to-connect ends shall be rated at 200 psi CWP to +250°F maximum. Valves shall be manufactured in accordance with MSS SP-80. Body and cap to be manufactured of dezincification resistant cast bronze (ASTM B 62 or ASTM B 584 Alloy C84400). Valves to have PTFE seat disc.

#### Acceptable Valves:

NIBCO® PF413-Y or PS413-Y - Y pattern, swing type check valve  
NIBCO® PF480-Y or PS480-Y - in-line spring loaded silent check valve

### Drain Valves

At all low points in water piping to be drained or vented, provide 1/2" or 3/4" ball valves with male or female press-to-connect ends by hose-end drain valves. Valves shall be rated by 200 psi CWP to +250°F maximum. Valves shall be manufactured in accordance with MSS SP-110. Valves to be constructed of dezincification resistant cast bronze bodies. Valve shall have reinforced PTFE seats, blow-out proof stem, and be full port. All valves shall be provided with 3/4" hose connection with cap and chain.

#### Acceptable Valves:

NIBCO® PS585-70-HC or PF585-70-HC

### 2 1/2" thru 4" Butterfly Valves: (On/Off, Isolation or Throttling)

Butterfly valves with female press-to-connect ends shall be rated at 200 psi CWP to +250°F maximum. Valves shall be manufactured in accordance with MSS SP-67 and constructed of a ductile-iron body, for bubble-tight shutoff, extended-neck for insulation, disc and lining suitable for potable water, valves shall be suitable for bi-directional dead end service at full rated pressure, one-piece Type 416 stainless-steel stem, copper bushing, fasteners and pins shall not be used to attach stem to disc, no pins or fasteners in waterway, aluminum-bronze disc, and molded-in EPDM seat (liner).

#### Acceptable Valves:

NIBCO® PFD2000 series

Visit our website for the most current information.

**NIBCO**<sup>®</sup>  
**press**system  
Installation Instructions

*Visit our website for the most current information.*

# NIBCO® Press System — Installation Instructions

## NIBCO Press System

The NIBCO Press System, when used with tested and authorized pressing tools and jaws, is designed to mechanically crimp fittings and valves onto copper tubing to create a watertight, permanent seal. When the switch on the pressing tool is depressed a small hydraulic pump generates thousands of pounds of crimping force to install the specially designed fittings and valves.

## System Components

### Fittings and Valves

NIBCO Press System copper or bronze fittings and valves

### Tubing

ASTM B 88 seamless Hard Drawn Copper Water Tube: Types K, L and M as well as 1/2", 3/4" and 1" annealed copper tubing.

### Pressing Tools, Chains and Jaws

The pressing tool, chain and jaw are important parts of ensuring a reliable, permanent connection between NIBCO Press System fittings and valves and the copper water tube.

**CAUTION** — Use only pressing tools and jaw sets that have been tested and authorized for use with NIBCO Press System fittings and valves <sup>(1)</sup>. Use of unauthorized pressing tools and/or jaws may result in an improper seal that could cause extensive property damage.

(1) See approved tool and jaw compatibility matrix in this catalog.

## Chemical Compatibility

Please consult the most current edition of the NIBCO Chem-Guide for recommendations regarding chemical compatibility of material exposure to specific media and media-treatment additives. The NIBCO Chem-Guide is a general guide on the topic of chemical compatibility and is by no means an exhaustive resource on the subject. Ultimately, proper material selection is the responsibility of the installer and/or end-user, taking into account all aspects of a system's design and intended use.

## Galvanic Potential in Piping Systems

Galvanic corrosion or dissimilar metal corrosion is an electrochemical process that is created through the electrical interaction of two different metals under the influence of a conductive media (i.e. an electrolyte). An electrolytic cell, much like a battery, is generated by these dissimilar metals using water as the electrolyte. The electrical charge, developed within the electrolytic cell, drives a preferential attack on the more electrically active metal with the water acting as the recipient of the discarded metal ions. Such galvanic attack is often encountered in service where iron or steel components are installed, and later corrode, in a largely copper piping system. Please consult NIBCO Technical Bulletin NTB-0714-01 Dielectric Products Relative to Electrolysis and Galvanic Corrosion.

## Pressing Tool Safety

- Only use authorized pressing tools and jaws with NIBCO Press System fittings and valves. Other uses or modification of the jaws for other applications may damage the press tool, damage the jaws and/or cause personal injury.
- Keep fingers and hands away from jaws during pressing cycle. Your fingers or hands can be crushed, fractured or amputated if they become caught between the jaw tips or between the jaw and any other object.
- Always wear safety glasses while using pressing tools and jaws.
- Never attempt to repair a damaged jaw set. A jaw that has been modified in any manner can fail during crimping resulting in serious injury. Discard the entire damaged jaw set. Replace with a new jaw set.

**WARNING:** Please read these installation instructions and the manufacturer's pressing tool and jaw operators manual(s) carefully prior to installation of the NIBCO Press System. Failure to understand and follow the contents of this manual may result in extensive property damage, severe personal injury or death.

Please contact NIBCO Technical Services at 888.446.4226 if you have installation questions.

Visit our website for the most current information.

# NIBCO® Press System — Installation Instructions

## Installation Instructions for 1/2" - 2" Press Fittings and Valves

**WARNING:** To prevent serious injury, inspect the pressing tool, battery charger (if applicable) and jaw sets according to the procedure outlined in the pressing tool instruction manual prior to beginning installation.

Failure to clean jaws can result in an improper connection that can lead to extensive property damage.

### Preparing the Copper Tube

1. Select clean, undamaged copper tube and cut to desired length. Cut tube end square using a tube cutter or fine-toothed saw. Do not crimp over damaged, scratched, gouged, or otherwise damaged tubing ends. Do not crimp over etch print streams on tubing. (Figure 1).

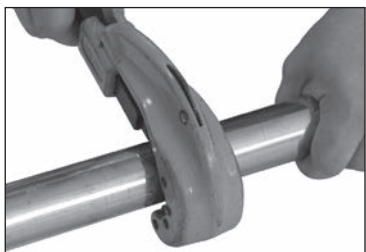

Figure 1 — Cut tube to desired length

2. Deburr the tube inside and outside diameter using a half-round file or a deburring tool.
3. Clean the tube end of all dirt, oil and grease. (Emery cloth or sandpaper to clean the tube or remove oxidation should not be used.)

### Inserting the Tube into the Fitting or Valve

1. Check the fitting to make sure the EPDM seal is in place, clean and free of dirt and debris (Figure 2).



Figure 2 — Check for EPDM Seal

**WARNING:** Never lubricate the EPDM seal in the NIBCO Press System fitting or valve with anything other than water. Oil-based lubricant, dirt or debris may damage the seal. An improper seal can lead to extensive property damage.

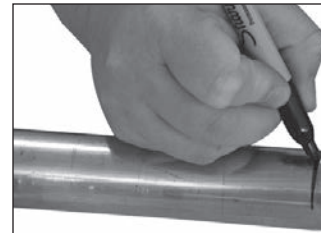

Figure 3 — Marking for Insertion Depth

2. Mark the tube with a permanent marker to indicate the proper tube insertion depth (Figure 3).
3. Refer to the minimum insertion depth table for correct depths
4. Insert the tube into the fitting or valve using a twisting motion. Make sure that the tube is fully inserted into the fitting stop or shoulder.

Tube Size	Insertion Depth (min.)	
	Inches	mm
1/2	11/16	18
3/4	7/8	22
1	7/8	22
1 1/4	1	25
1 1/2	1 3/8	35
2	1 1/2	38

**CAUTION:** Tubing that is difficult to insert may have burrs or could be out-of-round. Burrs must be removed and tubing end must be undamaged. Make sure tube is inserted to the proper depth. Failure to do so may result in an improper seal.

### Attaching Pressing Jaws

1. Make sure the battery is removed or the cord is unplugged on the pressing tool prior to attaching or changing the crimp jaws.
2. Push and twist to open the jaw set mounting pin. (Figure 4).



Figure 4 — Pushing and twisting to open the jaw set mounting pin

3. If press tool contains a jaw set, slide it out of the crimping tool.

Visit our website for the most current information.

# NIBCO® Press System — Installation Instructions

4. Select the jaw set that corresponds to the size of the joint to be crimped and insert the jaw set into the pressing tool (Figure 5).

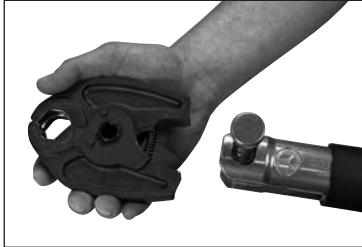

Figure 5 — Inserting the NIBCO Press System jaw

5. Push the jaw set mounting pin until it clicks into position.

NOTE: The tool will not properly press unless the pin is fully engaged.

## Crimping a NIBCO Press System Fitting or Valve

1. Make sure the tubing is inserted to the proper depth in the fitting. (Figure 6).

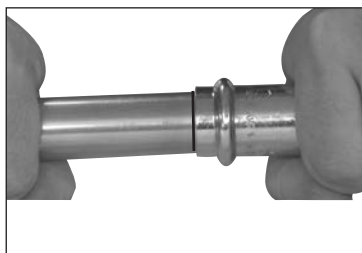

Figure 6 — Inserting the tube to proper depth

2. Squeeze jaw arms to open the jaw set.
3. Place the open jaws around the fitting and ensure that the contour of the jaw is properly aligned with the contour of the fitting (Figure 7).



Figure 7 — Open the jaw set and place around the fitting

4. Make sure the tool is perpendicular to the tubing and depress the switch (Figure 8). Keep the trigger depressed from the time the cycle begins and the rollers contact the jaw arms until the end of the entire crimp cycle.

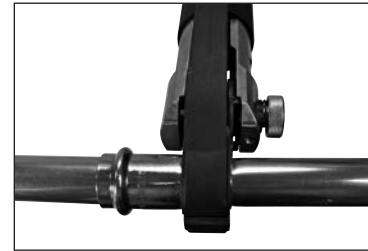

Figure 8 — Jaw set should be square to tubing

5. Once the crimp is complete, press the jaw arms to open the jaw and remove from the fitting.

If the tool displays an LED flash or emits an audible alarm, please refer to the tool instruction manual for troubleshooting suggestions.

**CAUTION** Avoid handling sharp edges that may have formed on the fitting during the crimping operation.

## Inspecting the Crimp

1. Inspect the crimped fitting to ensure proper crimp.

**NOTE:** The use of the NIBCO Press System jaw will produce a unique witness mark "N" on the crimped fitting.

2. Inspect the crimped fitting checking the connection for the following problems:

- Not fully inserted tube, double check depth marks
- Incorrect jaw alignment with the fitting contour

If any problems are found, a new section of tubing and a new fitting will need to be prepared, installed and crimped.

3. Test the NIBCO Press System in accordance with crimp integrity testing instructions for fittings and valves in this catalog.

Visit our website for the most current information.

# NIBCO® Press System — Installation Instructions

## Installation Instructions for 2 1/2" - 4" Press Fittings and Valves

**WARNING:** To prevent serious injury, the pressing tool, battery charger (if applicable) and pressing chains should be inspected according to the procedure outlined in the pressing tool instruction manual prior to beginning installation.

Failure to clean pressing chains can result in an improper connection that can lead to extensive property damage.

### Preparing the Copper Tube

1. Select clean, undamaged copper tube and cut to the desired length. Cut tube end square using a tube cutter or fine-toothed saw. Do not crimp over damaged, scratched, gouged, or otherwise damaged tubing. Do not crimp over etch print streams on tubing (Figure 1).



Figure 1: Cut tube to desired length using a tube cutter

2. Deburr the tube inside diameter using a half-round file or deburring tool. Remove any copper shavings or filings (Figures 2 & 3).

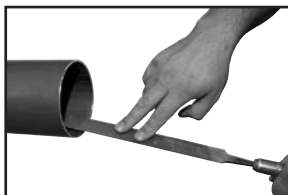

Figure 2: Deburr inside diameter using a half-round file



Figure 3: Deburr inside diameter deburring tool

3. Deburr the tube outside diameter using a half-round file to prevent damage to the EPDM seal (Figure 4).

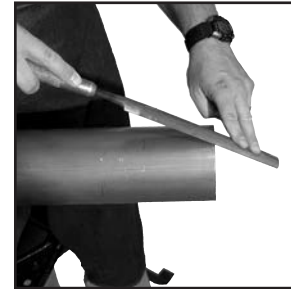

Figure 4: Deburr outside diameter using a half-round file

4. Clean the tube end of all contamination, oils and shavings. A smooth transition chamfer is recommended to ease tube insertion past the seal. (Emery cloth or sandpaper to clean the tube or remove oxidation **should not be used**.)

### Inserting the Tube into the Fitting or Valve

1. Check the fitting to make sure that the seal is in place and is free of oil or grease. Only original NIBCO® EPDM seals are to be used when making a press connection with NIBCO Press System fittings and valves. If it is necessary to lubricate the seals, use water only. **DO NOT** use any petroleum-based lubricants (Figure 5).



Figure 5: Check for EPDM seal

**WARNING:** Never lubricate the EPDM seal in a NIBCO Press System fitting or valve with anything other than water. Oil-based lubricants, dirt or debris may damage the seal. An improper seal can lead to extensive property damage.

2. Mark the proper insertion depth on the tube with a permanent marker prior to insertion, based on insertion depth chart. Refer to minimum insertion depth table for correct depths.

NIBCO® Press System Insertion Depth Chart			
Tube Size	2 1/2"	3"	4"
Insertion Depth (min.)	1 1/2"	1 5/8"	2 1/8"

3. Insert the tube into the fitting or valve using a twisting motion. Make sure that the tube is fully inserted into the fitting or valve.

**WARNING:** If tube is not inserted to the proper depth, an inadequate seal may result.

**CAUTION:** Tubing that is difficult to insert may have burrs or could be out-of-round. Burrs must be removed and tubing end should be undamaged. Make sure tube is inserted to the proper depth. Failure to do so may result in an improper seal.

Visit our website for the most current information.

# NIBCO® Press System — Installation Instructions

## Crimping a NIBCO Press System Fitting or Valve

### CAUTION:

NIBCO press fittings and valves (2½", 3", 4" ends) to be installed **ONLY** with:

- NIBCO PC-100 and PC-280 pressing tools
- NIBCO PC-5 adapter jaw
- NIBCO pressing chain - 2½" (PC-2), 3" (PC-3), 4" (PC-4)

1. Make sure that the battery is removed or that the cord is unplugged on the pressing tool prior to attaching or changing the adapter jaw.
2. Select the correct size pressing chain. Pull the pin on the chain which allows the segments to open. Position the chain on the raised bead and wrap the chain around the fitting with the "pipe side" designation facing the tube. When the chain is fully wrapped around the fitting, reinsert the pin to secure the chain on the assembled joint. Visually inspect the mark made for insertion depth, to ensure the tube remained in position (Figure 6).



Figure 6: Placement of the pressing chain onto fitting or valve

3. Release the pin (push and twist) on the jaw holder of the pressing tool, and install the adapter jaw on the tool. Return the pin to its original position, securing the jaw. The red sleeve on the tool must be in the back position to allow for crimping sizes 2½", 3" and 4" (Figure 7).



Figure 7: Placement of adapter jaw into the tool

4. Squeeze adapter jaw arms to open the jaw. Rollers must be fully retracted to open the adapter jaw. Place the open adapter jaw into the grooves in the pressing chain and let go of the jaw arms (Figure 8).



Figure 8: Placement of adapter jaw into pressing chain

5. Make sure the tubing is inserted to the proper depth in the fitting or valve, and that the tube and fitting or valve are aligned properly.
6. With the pressing tool perpendicular to the tube, begin the pressing cycle by pulling the trigger of the pressing tool.
7. Keep the trigger depressed from the time the cycle begins and the rollers contact the jaw arms until the end of the entire cycle. Remove the pressing tool and adapter jaw from the pressing chain. Remove the pressing chain from the fitting.

If the tool displays an LED flash or emits an audible alarm, please refer to the tool instruction manual for troubleshooting suggestions.

**CAUTION:** Avoid sharp edges that may have formed on the fitting during the crimping operation.

### Inspecting the Crimp

1. Inspect the crimped fitting or valve to ensure proper crimp. The final crimp should appear pressed uniformly around the fitting or valve (Figure 9).

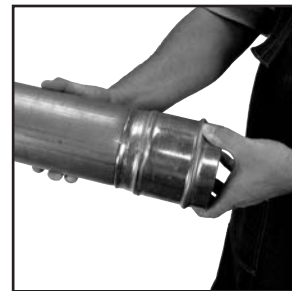

Figure 9: Inspection of final crimp

**NOTE:** The use of the NIBCO Press System chain will produce a unique witness mark "N".

2. Inspect the crimped fitting checking the connection for the following problems:
  - Not fully inserted tube, double check depth marks
  - Incorrect chain alignment with the fitting contour
 If any problems are found, a new section of tubing and a new fitting will need to be prepared, installed, and crimped.
3. Test the NIBCO Press System in accordance with crimp integrity testing instructions for fittings and valves in this catalog.

Visit our website for the most current information.

# NIBCO® Press System — Crimp Integrity Testing Instructions for Fittings & Valves

## PRESSURE TESTING:

NIBCO recommends the following leak testing procedures when installing NIBCO Press System with the leak detection feature. These test procedures allow the installer to find un-pressed connections while the system is being tested under pressure. The uniquely designed EPDM o-ring allows fluids or gases to flow past the seal and leak when the fitting has not yet been pressed. When the fitting has been pressed, the o-ring will create a water tight seal around the tube.

## AIR LEAK TESTING:

1. Pressure system slowly increasing to a maximum of 15 psi maximum using dry, oil free compressed air, carbon dioxide, or nitrogen.
2. Allow system pressure to stabilize for a minimum of 2 hours.
3. If system pressure has dropped, add more air to bring entire system up to 15 psi maximum. If system pressure increases above 15 psi, bleed off excess pressure to ensure system is at a maximum pressure of 15 psi.
4. If the system pressure continues to drop, inspect all joints for un-pressed fittings. The NIBCO Press System press fittings with the leak detection feature are designed to leak in an un-pressed condition.
5. Check all press joints for air leaks using a commercially available leak test solution or a soap and water mixture. Do not use a soap that contains Mineral Spirits or a Hydrocarbon/ petroleum that might attack the EPDM O-rings.
6. Once the system has been confirmed to be leak free, pressure can be increased to the recommended working pressure to verify system integrity.

## WATER LEAK TESTING:

1. Pressurize system up to 50 psi maximum using potable water.
2. Allow system pressure to stabilize for a minimum of 2 hours.
3. If system pressure has dropped, add more water to bring entire system up to 50 psi maximum. If system pressure increases above 50 psi, bleed off excess pressure to ensure system is at a maximum pressure of 50 psi.
4. If the system pressure continues to drop, inspect all joints for un-pressed fittings. The NIBCO Press System press fittings with the leak detection feature are designed to leak in an un-pressed condition.
5. Check all press joints for leaking water.
6. Once the system has been confirmed to be leak free, water pressure can be increased to the recommended working pressure to verify system integrity.

---

## SYSTEM INTEGRITY TESTING\*:

**Once a system has been confirmed to be properly installed and no press connections have been left uncrimped**, the system is recommended for testing up to the maximum non-shock working pressure as indicated in the Press Fittings Applications Chart reported in this catalog.

NOTE: While NIBCO Press System products are tested to pressures as high as 600 psi, the product system rating limitation of 200 psi is in place to ensure a safety factor of three-times proof-testing according to ASME B16.51 Copper and Copper Alloy Press-Connect Pressure Fittings.

## SYSTEM INTEGRITY TESTING AT HIGHER PRESSURES\*:

NIBCO Press System products can be tested at hydrostatic pressures higher than 200 CWP, not exceeding a maximum pressure of 300 psi hydrostatic for a maximum test duration of 24 hours, when assembled and tested according to the methods prescribed above.

**CAUTION:** These testing parameters and protocols apply only to NIBCO products as detailed above: NIBCO accepts no responsibility or liability for any other manufacturer's products that may be damaged as a result of such testing.

\*System integrity testing applies to leak detect and non-leak detect fittings and valves.

Visit our website for the most current information.

# NIBCO® Press System — Installation Instructions

## Minimum Distance Between Joints

To prevent distortion of the tubing, certain fitting sizes require a minimum distance between crimp joints (refer to *Chart 1* below). Failure to provide this minimum distance may result in an improper seal.

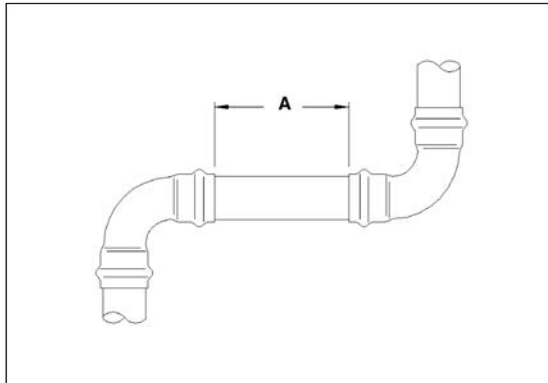

Tube Dia.	A (min.)	
	Inches	mm
1/2**	0	0
3/4**	0	0
1**	0	0
1 1/4**	0	0
1 1/2**	0	0
2**	0	0
2 1/2"	3/8"	10
3"	3/8"	10
4"	3/8"	10

\*No minimum distance required.

## System Support

**CAUTION** — In any installation, the system should be supported to ensure the minimum stress is imposed on the tube and joints. The NIBCO Press System should be supported in accordance with normal practice and to local jurisdiction piping code.

## Softening of Copper Tubing

A NIBCO Press System installation should not be conducted within 12" of a **brazed** joint. The high temperature required for capillary joinery may cause the copper tube to become annealed and render it too soft for proper crimping. However, a NIBCO Press System product may be crimped adjacent to a **soldered** joint, as normal temperatures created by silver soldering are not hot enough to cause the copper tube to become annealed.

**CAUTION** — Brazing or soldering should not be conducted within 12" of an existing NIBCO Press System connection as this may damage the HNBR seal. If there is any concern about heat damage to the O-ring, a cold, wet cloth should be wrapped around the crimped connection prior to soldering or brazing.

## Spacing

1. Sufficient clearance must be left around each joint to allow room for the pressing tool and jaw to be attached without interference.

Clearance Requirement — NIBCO Standard Sets

### Tool perpendicular to wall

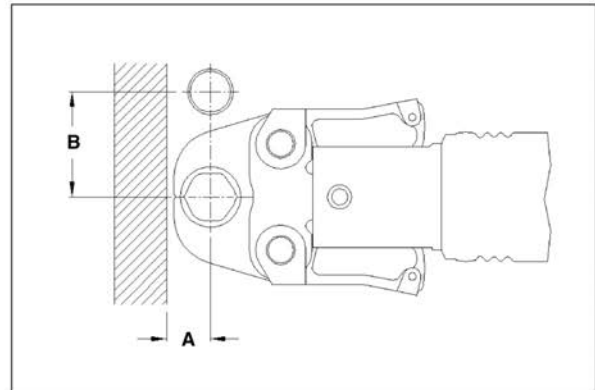

Tube Dia.	A (min.)		B (min.)	
	Inches	mm	Inches	mm
1/2	15/16	24	1 5/8	41
3/4	7/8	22	2 1/8	54
1	1 1/4	31	2 1/2	64
1 1/4	1 1/8	29	2 7/8	73
1 1/2	2	51	4 3/8	111
2	2	51	4 3/8	111

### Tool angled to wall

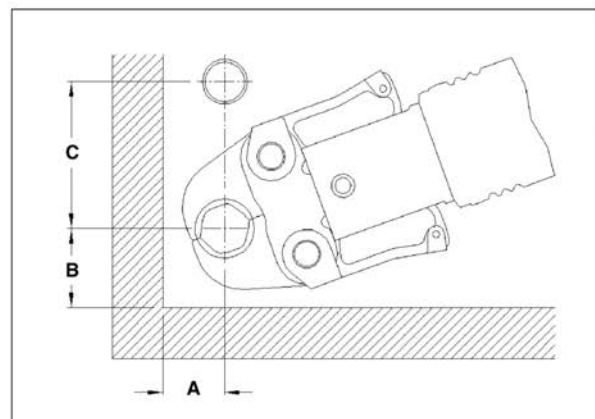

Tube Dia.	A (min.)		B (min.)		C (min.)	
	Inches	mm	Inches	mm	Inches	mm
1/2	1 1/8	28	1 3/8	35	2 1/2	64
3/4	1	26	1 1/2	38	2 1/2	64
1	1 5/16	34	1 3/4	45	3	76
1 1/4	1 1/4	32	2 1/4	57	3 1/8	80
1 1/2	2 1/8	54	3 1/8	80	5	127
2	2 1/8	54	3 1/8	80	5	127
2 1/2	4 1/2	114	4 11/16	119	6 1/8	156
3	4 3/4	121	5	128	6 7/8	175
4	5 1/4	134	5 11/16	145	7 7/8	200

**NOTE:** Clearance dimensions for 2 1/2", 3" & 4" are for wrapping pressing chains around fittings.

Visit our website for the most current information.

# NIBCO® Press System — Frequently Asked Questions

## What is the NIBCO product offering?

NIBCO Press System features a full range of copper and copper alloy fittings, commercial valves, accessories and pressing tools, jaws and chains for use with K, L and M copper water tube as well as 1/2", 3/4" and 1" annealed copper tubing.

## What is the system temperature rating?

NIBCO Press System is rated at 200 psiG over a temperature range of -20°F to 250°F.

## What are the approved system applications?

Approved applications include residential and commercial potable, hot, chilled and process water for plumbing and HVAC systems. NIBCO Press System is designed for use with water glycol mixtures of ethylene or propylene glycol up to 50% at 200°F.

## What was the testing protocol for NIBCO Press System fittings and valves?

NIBCO Press System fittings and valves were subjected to a wide range of performance tests including dimensional verification, thread end specification, hydrostatic burst strength, unrestrained pressure, static torque, bending, vacuum pressure, cyclic pressure, vibration, thermo-cycling and dynamic torque. The testing protocol included testing to a 3X safety factor above the 200 psiG system rating.

NIBCO testing was witnessed and validated by the internationally recognized NSF.

## Can other available pressing tools and jaws be used on the NIBCO Press System?

See our Approved Tool and Jaw Compatibility Matrix for a complete listing of approved tools and jaws.

## Can a NIBCO Press System connection be re-crimped?

If for any reason the press cycle is interrupted, it is possible to re-crimp a NIBCO Press System connection. However, when re-crimping the connection, the jaws must be properly aligned so that the crimp is performed in the same location as the original.

## How long will the EPDM seal last?

Accelerated life tests show that the EPDM seals used with NIBCO Press System fittings and valves have a life expectancy of 50 years.

## Are NIBCO Press System fittings available with solder or threaded by Press System connection?

NIBCO offers many Press System fitting combinations by soldered or threaded connection. Please note, always solder the standard wrought connection first when possible. Prior to soldering, remove the press end EPDM o-ring, solder, allow the fitting to cool, insert the EPDM O-ring, and then Press the connection.

## Can a fitting be soldered close to a Press System connection?

NIBCO recommends soldering at least 12 inches away from the Press System connection. If this length is not possible, either solder the joint prior to connecting the press fitting or wrap the connection with a cold wet cloth.

## Is NIBCO Press System approved for underground use?

In accordance with local plumbing codes, NIBCO Press System can be installed underground.

## Is NIBCO Press System compatible with standard disinfectant cleaning agents commonly utilized in a new water system?

With regard to cleaning and/or disinfecting any copper piping system, NIBCO recommends following the general guidelines offered by the Copper Development Association (see Commissioning and Disinfecting Copper Plumbing Systems for details at [www.copper.org](http://www.copper.org).)

Visit our website for the most current information.

# NIBCO® Press System Limited Warranty

## NIBCO INC. LIMITED WARRANTY

Applicable to NIBCO Press System

NIBCO INC. warrants each NIBCO Press System fitting and flange to be free from defects in materials and workmanship under normal use, service, and maintenance in accordance with the product specifications (including, but not limited to installation recommendations) for a period of fifty (50) years from the Warranty Commencement Date. The Warranty Commencement Date shall be the date of installation.

NIBCO Press System pressure rated metal valves to be free from defects in materials and workmanship under normal use, service, and maintenance in accordance with the product specifications (including, but not limited to installation recommendations) for a period of five (5) years from the Warranty Commencement Date, except for model PC-FP-600A-LF for which a period of two (2) years from the Warranty Commencement Date shall apply. The Warranty Commencement Date shall be the date of installation.

NIBCO Press System tools to be free from defects in materials and workmanship under normal use, service, and maintenance in accordance with the product specifications for a period of two (2) years from the date of purchase.

NIBCO Press System fittings, flanges, valves, and tools are referred to herein as "NIBCO Products."

NIBCO will repair or replace – at its option and at no charge – NIBCO Products that have been determined by NIBCO, or an authorized representative or agent thereof, to have failed solely because of a defect in materials or workmanship under normal use, service, and maintenance during the warranty period. Replacements shall be shipped free of charge to the owner.

This limited warranty applies to all NIBCO Products installed, tested, applied, and used in accordance with NIBCO's approved and published recommendations and instructions.

This warranty does not cover any failure or damage for or caused by:

1. any product, parts, or systems which are not manufactured or sold by NIBCO;
2. any NIBCO Product which is used for purposes other than a purpose authorized by NIBCO;
3. any NIBCO Product not installed, tested, applied, used, or maintained in accordance with NIBCO's recommended installation guidelines and instructions;
4. any NIBCO Product not installed or used in accordance with applicable codes;
5. any damage caused by, contributed in whole or in part by, or resulting from, any of the following:
  - a. abuse, misuse, mishandling, alteration, tampering, neglect, or accidental damage such as, without limitation, vandalism;
  - b. natural disasters, such as, without limitation, flooding, windstorm, and lightning;
  - c. attachments or modifications not authorized by NIBCO;
  - d. external, physical or chemical qualities, or an unsuitable or hostile environment;
  - e. any defects other than those in material or workmanship; or
  - f. any other cause beyond the control of NIBCO.

NIBCO DISCLAIMS ANY AND ALL LIABILITY FOR ANY OTHER DIRECT OR INDIRECT, INCIDENTAL, OR CONSEQUENTIAL DAMAGES OF ANY KIND, INCLUDING BUT NOT LIMITED TO, ECONOMIC LOSS, LOSS OF BUSINESS, LOST PROFITS, PUNITIVE DAMAGES, MOLD INTRUSION, WATER DAMAGE, ETC.

Some states do not allow the exclusion or limitation of damages, so the above limitation or exclusion may not apply to you.

THIS WARRANTY IS THE ONLY WARRANTY FOR THE NIBCO PRODUCTS PROVIDED BY NIBCO, AND IS AND SHALL BE IN LIEU OF ANY AND ALL OTHER WARRANTIES, EXPRESSED OR IMPLIED, INCLUDING, BUT NOT LIMITED TO, AN IMPLIED WARRANTY OF MERCHANTABILITY OR FITNESS FOR A PARTICULAR PURPOSE, AND FOR ALL OTHER OBLIGATIONS OR LIABILITIES ON THE PART OF A MANUFACTURER. NO EMPLOYEE OF NIBCO, OR ANY OTHER DISTRIBUTOR, AGENT, OR OTHER PERSON OR BUSINESS, IS AUTHORIZED TO MAKE ANY OTHER WARRANTY ON BEHALF OF NIBCO.

Some states do not allow limitations on implied warranties, so the above limitation may not apply to you.

In the event any defect occurs which is believed to be covered by this warranty, NIBCO Technical Services must immediately be contacted by calling 888.446.4226 or emailing CS-TechnicalServices@nibco.com. NIBCO Technical Services after being contacted will make further arrangements for the product's return to NIBCO at the customer's expense for review and evaluation.



## How to Order

State quantity, figure number and size for each valve you wish to order. See individual valve catalog pages for specific or special product designations.

### HOW MANY TO ORDER

NIBCO valves are decimal packed for your convenience in handling, shipping and stock-keeping. Number in master carton varies with item.

### POLICY ON RETURNS TO FACTORY

NO NIBCO valves are to be returned without prior written agreement. Transportation must be prepaid. A 20% charge will be made to cover cost of rehandling and reinspection.

### TECHNICAL ASSISTANCE

Engineers, contractors, wholesalers or manufacturers may obtain special or technical assistance from any factory representative of NIBCO. Write, fax or phone.

NIBCO INC.  
World Headquarters  
1516 Middlebury Street  
Elkhart, IN 46516-4740  
USA

Phone: 1.574.295.3000

Fax: 1.574.295.3307

Technical Service Phone: 1.888.446.4226

Fax: 1.888.336.4226

To the best of our knowledge, the information contained in this publication is accurate. However, NIBCO does not assume any liability whatsoever for the accuracy or completeness of such information. Final determinations of the suitability of any information or product for the use to be contemplated is the sole responsibility of the user. The manner of that use, and whether there is any infringement of patents, is also the sole responsibility of the user.



# NIBCO®

## Global Locations

### MANUFACTURING PLANTS

#### **Metal Fittings & Valves**

Blytheville, Arkansas

McAllen, Texas

Nacogdoches, Texas

Stuarts Draft, Virginia

Worcester, Massachusetts

#### **Plastic Pipe, Valves, & Fittings**

Goshen, Indiana

Greensboro, Georgia

#### **International**

Lodz, Poland

Reynosa, Mexico



### INTERNATIONAL OFFICES

#### **World Headquarters**

Elkhart, Indiana

#### **European Office**

Lodz, Poland



[VISIT OUR WEBSITE TO LEARN MORE](#)



Press Webstone PressACR Bench  
system Chemtrol NIBCO  
SURE SEAL FLO-BOSS Press  
NIBCO wrot racer FAST PUSH FITTINGS Bench PressG  
Bench Press Webstone PressACR  
presssystem NIBCO Chem  
PressG SURE SEAL FLO-BOSS  
G NIBCO wrot racer FAST PUSH FITTINGS Bench Press  
Press Webstone PressACR Bench  
system Chemtrol NIBCO pr  
SURE SEAL FLO-BOSS Press  
NIBCO wrot racer FAST PUSH FITTINGS Bench PressG  
Bench Press Webstone Press  
NIBCO presssystem Chemtr  
OSS PressG SURE SEAL FLO  
essACR Bench

# NIBCO®

NIBCO INC.  
WORLD HEADQUARTERS

1516 MIDDLEBURY STREET  
ELKHART, IN 46516-4740 USA  
WEB: [www.nibco.com](http://www.nibco.com)

DOMESTIC CUSTOMER SERVICE  
PHONE: 800.234.0227  
FAX: 800.234.0557

TECHNICAL SERVICE  
PHONE: 888.446.4226  
FAX: 888.336.4226

INTERNATIONAL OFFICE  
PHONE: +1/574.295.3327  
FAX: +1/574.295.3455