



SERVICE PARTS LIST

BULLETIN NO.
54-00-2882

SPECIFY CATALOG NO. AND SERIAL NO. WHEN ORDERING PARTS		REVISED BULLETIN	DATE
M18™ FUEL™ One-Key™ Small Angle Grinder w/Brake			May 2022
CAT. NO. 2882-20 (Paddle)	STARTING SERIAL NO.	L68A	
2883-20 (Slide)		L69A	
		WIRING INSTRUCTION	

Model 2882-20
Paddle Switch

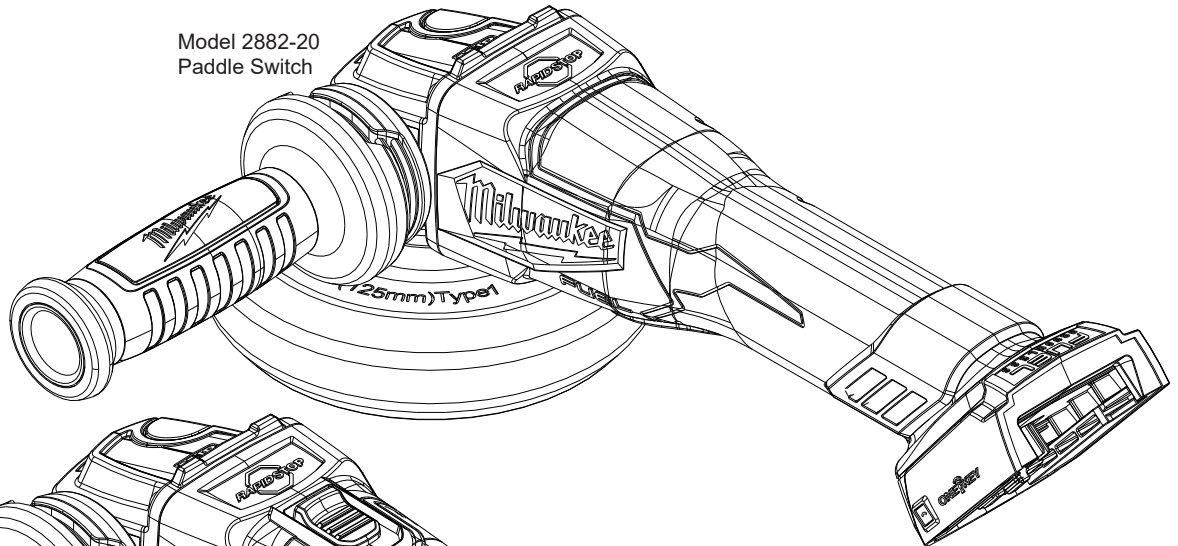

Model 2883-20
Slide Switch

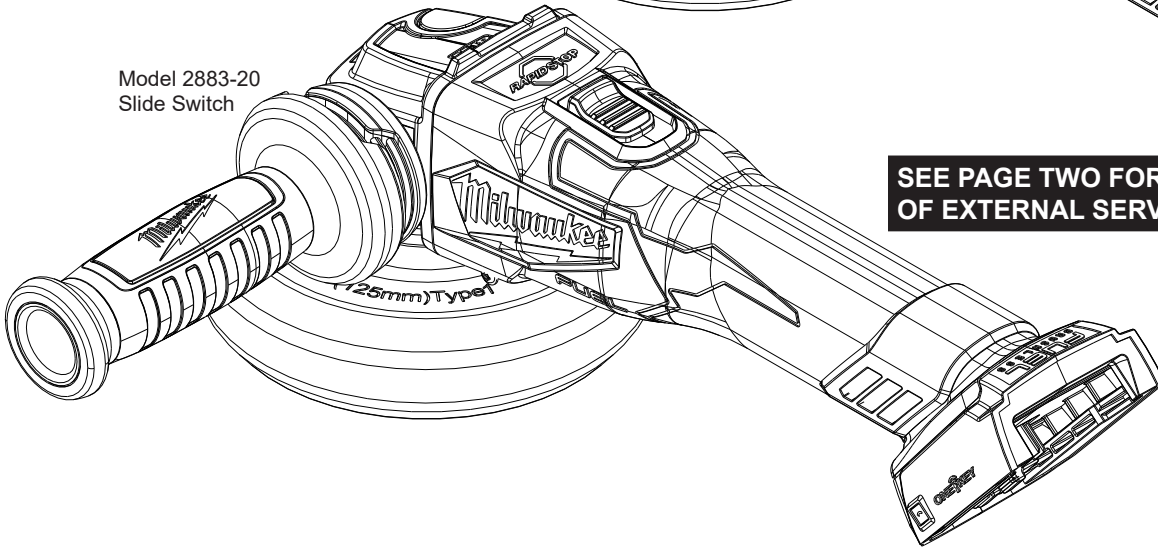

SEE PAGE TWO FOR THE REPLACEMENT OF EXTERNAL SERVICE COMPONENTS

Due to the complexities of One-Key™ electronics contact the following for service related questions and issues:

e-Service at: www.milwaukeetool.com/e-service

or

questions, please call 1.800.SAWDUST (1.800.729.3878)

or

Return it to a MILWAUKEE *factory* Service Center location, freight prepaid and insured. A copy of the proof of purchase should be included with the return product.

If you have questions please contact Milwaukee Product Service at:

Product Technical Support via phone at: 262.783.8642

or

Via email at: METProductSupport@milwaukeetool.com

Disassembly is not recommended and could void the warranty.



SERVICE PARTS LIST

BULLETIN NO.
54-00-2882

SPECIFY CATALOG NO. AND SERIAL NO. WHEN ORDERING PARTS		REVISED BULLETIN	DATE
M18™ FUEL™ One-Key™ Small Angle Grinder w/Brake			May 2022
CAT. NO. 2882-20 (Paddle)	STARTING SERIAL NO.	L68A	
2883-20 (Slide)		L69A	
		WIRING INSTRUCTION	

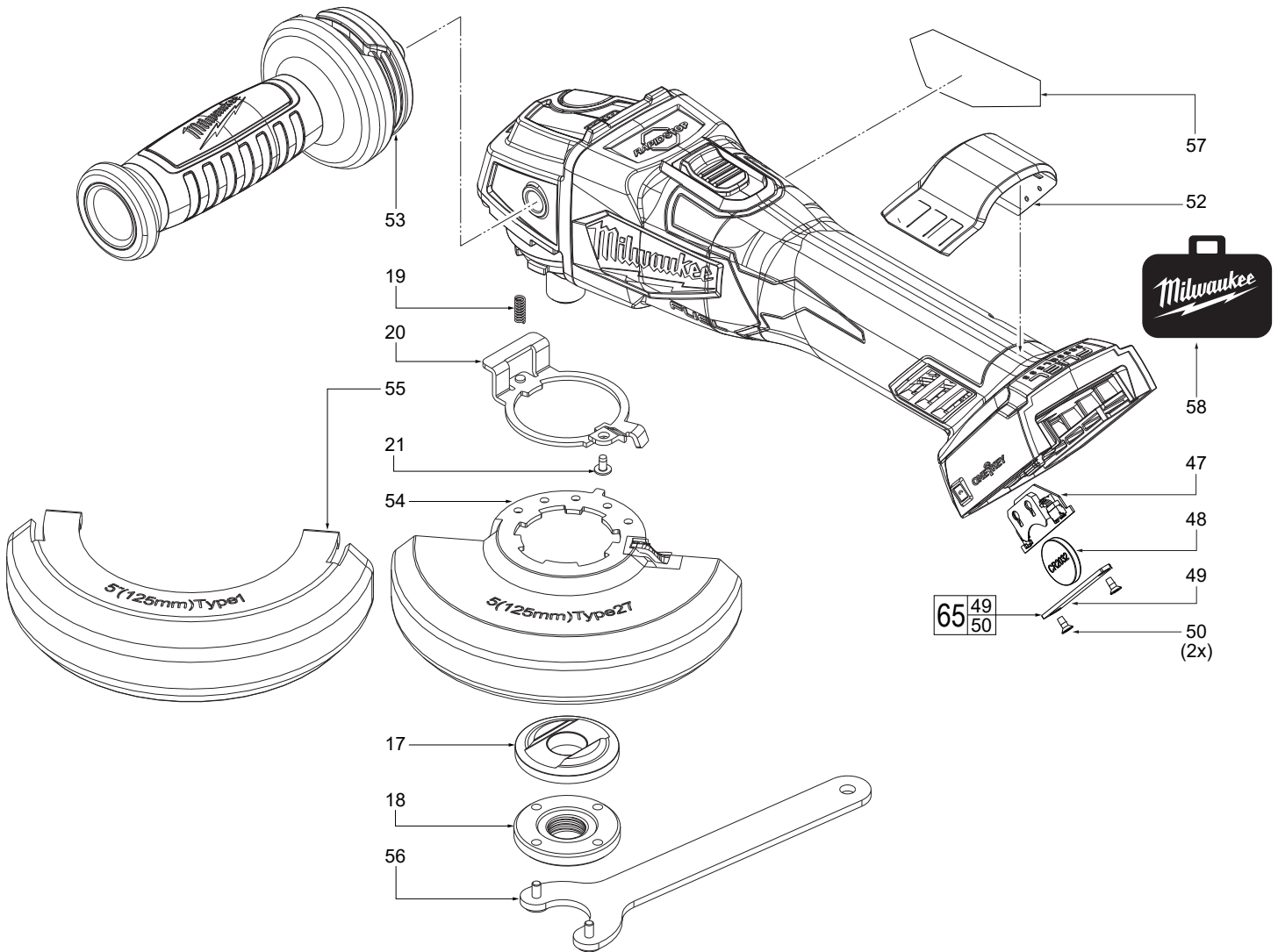

FIG.	PART NO.	DESCRIPTION OF PART	NO. REQ.
17	43-34-3000	Backing Flange Disc	(1)
18	44-40-7100	5/8" Flange Nut	(1)
20	44-20-0091	Guard Locking Tang	(1)
21	45-04-0031	M3 x 8.5mm Pan Washer Hd. Phillips Screw	(1)
47	22-09-0072	Coin Cell PCBA	(1)
48	-----	3V Coin Cell Battery (CR2032)	(1)
49	-----	Coin Cell Cover	(1)
50	05-81-1100	M2.6 x 6mm Flat Head Phillips ST Screw	(2)
52	31-15-0103	Dust Cover	(1)
53	42-62-0125	Side Handle Assembly	(1)
54	43-54-1221	5" Type 27 Guard Assembly (Std. Equip. Shown)	(1)
	43-54-1230	5" Type 1 Guard Assembly (Optional, Not Shown)	(1)
	43-54-1200	4.5" Type 27 Guard Assembly (Optional, Not Shown)	(1)
	43-54-1210	4.5" Type 1 Guard Assembly (Optional, Not Shown)	(1)
55	43-54-4010	5" Plastic Clip-On Guard Attachment	(1)
56	49-96-7215	Spanner Wrench	(1)
57	12-20-0366	Service Nameplate	(1)
58	50-55-3560	Contractor Bag	(1)
65	31-15-0148	Coin Cell Cover Kit	(1)