

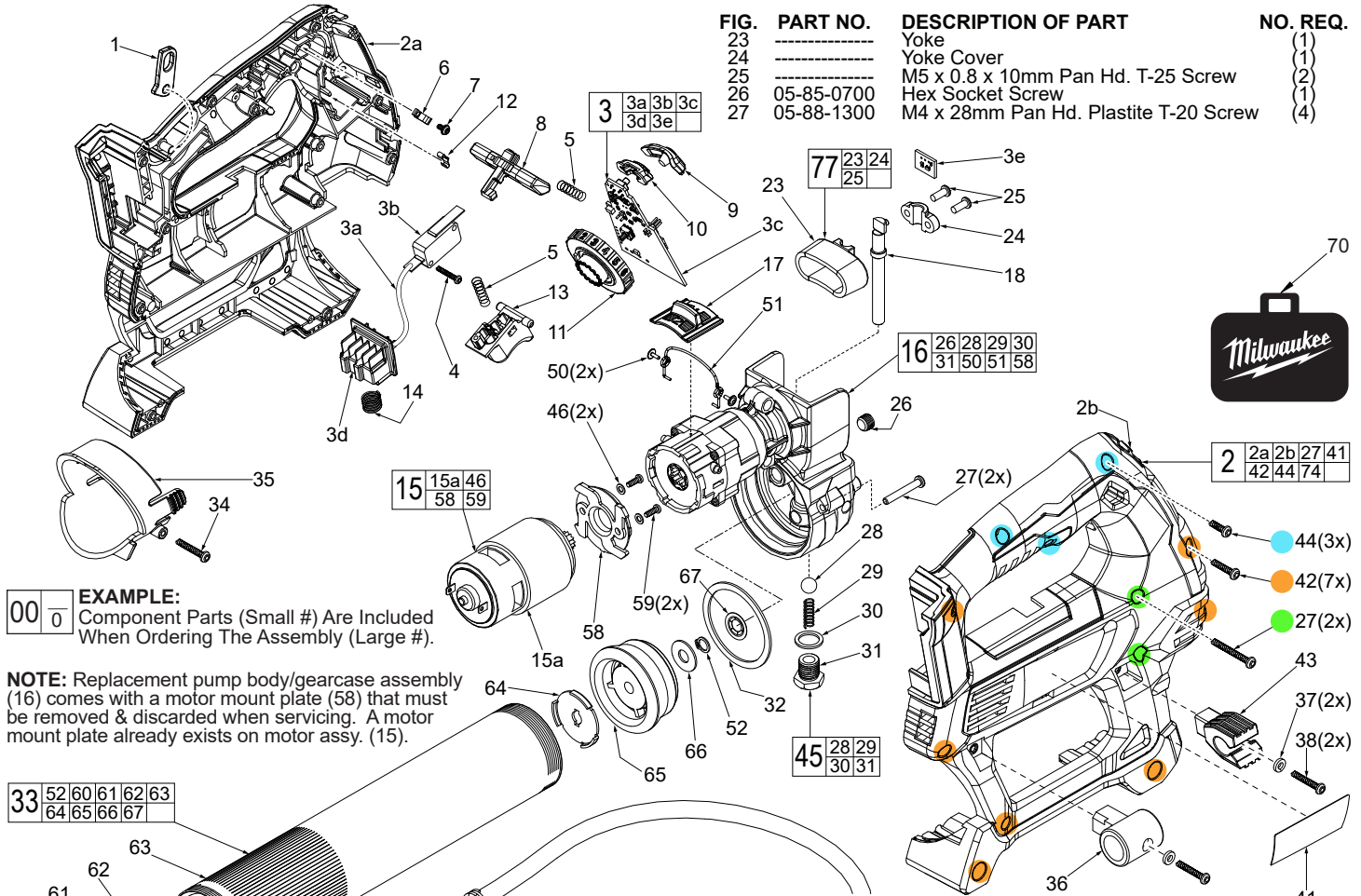

SERVICE PARTS LIST

BULLETIN NO.
54-06-2630

SPECIFY CATALOG NO. AND SERIAL NO. WHEN ORDERING PARTS		REVISED BULLETIN	DATE
M18™ Grease Gun			Nov. 2021
CATALOG NO.	2646-20	STARTING SERIAL	E98A
		WIRING INSTRUCTION	See Reverse Side



EXAMPLE:
Component Parts (Small #) Are Included When Ordering The Assembly (Large #).

NOTE: Replacement pump body/gearcase assembly (16) comes with a motor mount plate (58) that must be removed & discarded when servicing. A motor mount plate already exists on motor assy. (15).

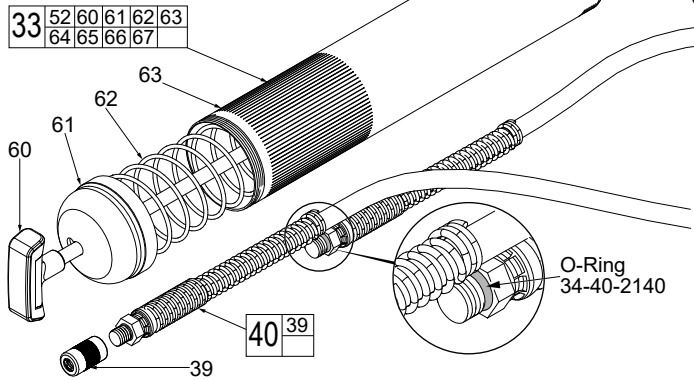

FIG.	PART NO.	DESCRIPTION OF PART	NO. REQ.
1	43-72-0022	Tool Holder/Hanger	(1)
2	31-50-0272	Housing Kit	(1)
2a	-----	Handle Support with Hanger Pin	(1)
2b	-----	Handle Cover	(1)
3	23-66-1145	Switch/Electronics Assembly	(1)
3a	-----	Red Leadwire	(1)
3b	23-66-2885	On-Off Switch	(1)
3c	-----	PCB Assembly	(1)
3d	-----	Battery Connector Block	(1)
3e	-----	Hall Sensor	(1)
4	06-82-2385	M2.6 x 14mm Pan Hd. Plastite T-8 Screw	(1)
5	40-50-0890	Spring	(2)
6	40-50-0232	Plate Spring	(1)
7	05-88-0030	M3 x 8.5mm Pan Hd. ST T-10 Screw	(1)
8	42-42-0037	Lock On-Off Shuttle	(1)
9	44-06-0177	Clear LED Cover	(1)
10	42-42-1045	LED Button Cover	(1)
11	43-98-0555	Counter Dial	(1)
12	40-50-0253	Plate Spring	(1)
13	45-72-0088	Switch Trigger	(1)
14	40-50-1090	Compression Spring	(1)
15	23-30-0770	Motor Assembly	(1)
15a	-----	Motor	(1)
16	44-70-0112	Pump Body/Gearcase Assembly	(1)
16a	-----	Pump Body/Gearcase	(1)
17	45-24-0033	Speed Selector Button	(1)
18	44-62-0105	Piston Assembly with Magnet	(1)

FIG.	PART NO.	DESCRIPTION OF PART	NO. REQ.
23	-----	Yoke	(1)
24	-----	Yoke Cover	(1)
25	-----	M5 x 0.8 x 10mm Pan Hd. T-25 Screw	(2)
26	05-85-0700	Hex Socket Screw	(1)
27	05-88-1300	M4 x 28mm Pan Hd. Plastite T-20 Screw	(4)
28	02-02-0265	3/8" Steel Ball	(1)
29	40-50-1685	Spring	(1)
30	45-88-0905	Washer	(1)
31	45-04-1010	Plug Screw	(1)
32	43-44-0087	Rubber Gasket	(1)
33	30-06-0205	Barrel Assembly	(1)
34	05-81-0012	M4 x 10mm Pan Hd. Taptite Phillips Screw	(1)
35	31-86-0005	Spacer for Steel Barrel	(1)
36	42-90-0045	Coupler Holster	(1)
37	05-90-0225	Lock Washer	(2)
38	05-88-0027	M4 x 0.7 x 16mm Pan Hd. Plastite T-20	(1)
39	42-90-0065	Coupler Assembly (Accessory)	(1)
40	14-37-0113	Grease Hose Assembly	(1)
41	12-20-2646	Service Nameplate	(1)
42	05-88-1250	M4 x 20mm Pan Hd. T-20 Screw	(7)
43	43-75-0200	Grease Hose Holster	(1)
44	05-88-1200	M4 x 16mm Pan Hd. T-20 Screw	(3)
45	45-04-1030	Plug Screw Kit	(1)
46	-----	Washer	(2)
50	05-81-0542	M2.3 x 6mm ST Phillips Hd. Screw	(2)
51	44-10-0030	Speed Selector Wire Link	(1)
52	44-86-1380	Retaining Ring	(1)
58	-----	Motor Mount Plate	(1)
59	-----	M4 x 8mm Pan Hd. Phillips Screw	(2)
60	44-94-0075	Plunger Rod with Handle	(1)
61	-----	Barrel Tube Cover	(1)
62	-----	Barrel Spring	(1)
63	-----	Barrel	(1)
64	44-66-1525	Steel Plate	(1)
65	45-06-0890	Rubber Seal	(1)
66	45-88-2030	Washer	(1)
67	44-86-1400	Self-Locking Retaining Ring	(1)
70	42-55-2647	Contractor Bag	(1)
75	45-56-0125	Shoulder Strap (Not Shown)	(1)
76	49-16-2438	Right Angle Adaptor (Not Shown)	(1)
77	45-98-0041	Yoke Assembly	(1)

AS AN AID TO REASSEMBLY,
TAKE NOTICE OF WIRE ROUTING AND
POSITION IN WIRE GUIDES AND TRAPS
WHILE DISMANTLING TOOL.

BE CAREFUL AND AVOID PINCHING
WIRES BETWEEN HANDLE HALVES
WHEN ASSEMBLING.

NOTE:

Route wires from PCBA and Battery Connector Block in this area. Press wires down firmly and cover with On-Off Switch. Switch is to be placed over the post in the handle and seated squarely. Secure with screw. DO NOT over-tighten.

● = WIRE TRAPS
or GUIDES

