



**SINCE 1952**

**OPERATION & MAINTENANCE MANUAL**

**2"-16" NON-RISING STEM  
RESILIENT WEDGE GATE VALVES**

## **Preface**

### What A Resilient Wedge Valve “IS NOT”!

1. A resilient wedge gate valve IS NOT for use in steam applications.
2. A resilient wedge gate valve IS NOT for use in hydrocarbon applications.
3. Resilient wedge flange gate valves have flat face flanges. NEVER use raised face flanges on resilient wedge gate valves.
4. Resilient wedge gate valves ARE NOT throttling valves. They must be used in a fully open or fully closed position only.

**Overview:** This manual is designed to describe the proper storage, installation, operation and maintenance of gate valves distributed by Matco-Norca. These procedures have been reviewed to conform to standard industry practices. Inspect all valves at time of delivery for damage caused by shipping. Confirm the valves comply with your specifications. Read information on the valve tag wired to each stem.

## **1. Storage**

- a. Valves should be stored in a closed position and indoors. If it is not possible to store them indoors then take care to protect them from exposure to weather and debris. In cold weather climates make absolutely certain no water is trapped in the valve.
- b. Under no circumstance should water be allowed to freeze in the valve. Severe damage will result to valve components.
- c. Do not store valves in direct sunlight for an extended period of time.

## **2. Installation**

- a. At all points in installing the valve special care should be taken to ensure there is no damage to the valve and that no damage will be done to the valve by any methods used to install the valve.
- b. Check that valve end joints are clean and free from debris. Completely open and close the valve and visually inspect to ensure full and proper operation.
- c. Ensure the valve is completely closed before placing in the pipeline or trench.
- d. Care should be taken to handle the valve carefully. Never drop the valve in the trench. Never use a sling or chain through the port opening or around the valve stem. Only use slings that fully cradle the valve when lowering into place.
- e. Always install the valve on the pipe using the proper method for the type of end joint. Manufacturer's instructions for the pipe ends should be prepared per those manufacturer's instructions. Pipelines must be level, square, and plumb. Properly support the valve to avoid undue stress on the valve.
- f. Debris in the system must be removed by flushing the entire system. Debris left in the system can cause severe damage to the valves or the valve components.

- g. Pressure test the line with water, never air. **DO NOT BURY OR BACKFILL VALVES UNTIL PRESSURE TEST IS COMPLETE.**
- h. All valve boxes should be installed on each valve so that no load is transferred to the valve.

### 3. Operation

- a. The rated working pressure is cast into the body or printed on the aluminum identification tag of each valve. Do not operate valves in systems that exceed the rated working pressure of the valve.
- b. Resilient wedge valves open and close by operating the valve stem. This operation is performed by turning the operating nut with a valve key or by turning the hand wheel. This operation causes the resilient wedge in the valve to ride up and down. The compressing of the resilient material bonded to the wedge against the valve body is what creates a seal. Torque requirements approach the maximum as the wedge is being compressed at the end of the closing cycle. Opening the valve requires less torque. See Table 1 below for torque pressure (in foot pounds) to close the valve.
- c. If the valve does not seal after compressing the wedge against the valve body open and close the valve several times in an attempt to reseat the wedge. Be certain the desired amount of torque is being applied to the valve. If the valve still does not seal the pressure to the valve should be turned off and relieved. The bonnet or top section of the valve should be removed so the wedge can be inspected for damage and the waterway can be inspected for debris.

## **Table 1- APPROXIMATE CLOSING TORQUES**

### **200 Series Cast Iron Valves**

*(Includes 200M, 200W, 200FJ, 100RT)*

2"	44 Foot Pounds
2-1/2"	55 Foot Pounds
3"	59 Foot Pounds
4"	74 Foot Pounds
6"	110 Foot Pounds
8"	147 Foot Pounds
10"	184 Foot Pounds
12"	221 Foot Pounds

### **200D Series Ductile Iron Valves**

*(Includes 200MD, 200WD, 200RTD, 200C9D, 200TVD)*

2"	45 Foot Pounds
2-1/2"	50 Foot Pounds
3"	55 Foot Pounds
4"	75 Foot Pounds
6"	110 Foot Pounds
8"	150 Foot Pounds
10"	185 Foot Pounds
12"	225 Foot Pounds

### **100 Series Cast Iron Valves**

*(Includes 100M, 100W, 105W)*

14"	181 Foot Pounds
16"	217 Foot Pounds

#### **4. Maintenance and Inspection**

- a. Resilient wedge gate valves require operation (exercise) at least every six months if the valves are not operated regularly under normal conditions. Exercising of the valve consists of fully opening and fully closing the valve.
- b. At the time of visual inspections the need to insure that the gate is seating properly can be accomplished by opening and closing the valve while counting the number of turns it takes. If the number of turns is not what is listed in Table 2 then an obstruction or other problem may have occurred. Table 2 has the listing of the number of turns it takes to open the different Matco AWWA valves. See Valve Disassembly instructions if cycling the valve does not allow the valve to seal.
- c. All gaskets and joints should be checked for leakage. In general the valves should be inspected for leaks and ease of operation at least every six months and exercised at that time.
- d. OS&Y valves should have the exposed stem lubricated at each inspection. Check bolts for tightness.

## **Table 2- TURNS TO OPEN**

### **200 Series Cast Iron Valves**

*(Includes 200M, 200W, 200FJ, 100RT)*

2"	10
2-1/2"	13
3"	16
4"	20
6"	25
8"	34
10"	42
12"	50

### **200D Series Ductile Iron Valves**

*(Includes 200MD, 200WD, 200RTD, 200C9D, 200TVD)*

2"	7
2-1/2"	9
3"	11
4"	13
6"	16
8"	25
10"	21
12"	25

### **100 Series Cast Iron Valves**

*(Includes 100M, 100W, 105W)*

14"	42
16"	48

## **Valve Disassembly and Bonnet Assembly**

If after cycling the valve it still will not seal there may still be an easy solution to fixing the valve without taking the valve body out of line. Turn the line pressure off to the valve. Unbolt the top part of the valve (bonnet) from the valve body by following the instructions below. This function “CANNOT” be performed with the valve under pressure. See Table 3 for the wrench size needed to unbolt the bonnet.

- a. On 200M and 200MD valves remove the protective wax (hot melt) covering the bonnet bolts.
- b. Remove the bonnet bolts.
- c. Lift off the bonnet assembly.
- d. Inspect the wedge for damage and also inspect the waterway of the valve for damage or debris. Replacement wedges are available if necessary.
- e. Install new bonnet gasket and make sure the bonnet gasket is securely in place. Reassemble in reverse order.
- f. Tighten bolts to recommended torques in Table 4.

### **Table 3- Bonnet Bolt Size**

#### **200 Series Cast Iron Valves**

*(Includes 200M, 200W, 200FJ, 100RT)*

2"	10 mm Allen Wrench
2-1/2"	10 mm Allen Wrench
3"	10 mm Allen Wrench
4"	10 mm Allen Wrench
6"	10 mm Allen Wrench
8"	14 mm Allen Wrench
10"	14 mm Allen Wrench
12"	14 mm Allen Wrench

#### **200D Series Ductile Iron Valves**

*(Includes 200MD, 200WD, 200RTD, 200C9D, 200TVD)*

2"	8 mm Allen Wrench
2-1/2"	10 mm Allen Wrench
3"	10 mm Allen Wrench
4"	10 mm Allen Wrench
6"	10 mm Allen Wrench
8"	10 mm Allen Wrench
10"	14 mm Allen Wrench
12"	14 mm Allen Wrench

#### **100 Series Cast Iron Valves**

*(Includes 100M, 100W, 105W)*

14"	7/8" Hex
16"	1" Hex

## Table 4- Bonnet Bolt Torques

### 200 Series Cast Iron Valves

*(Includes 200M, 200W, 200FJ, 100RT)*

2"	59 Foot Pounds
2-1/2"	59 Foot Pounds
3"	59 Foot Pounds
4"	59 Foot Pounds
6"	89 Foot Pounds
8"	133 Foot Pounds
10"	133 Foot Pounds
12"	133 Foot Pounds

### 200D Series Ductile Iron Valves

*(Includes 200MD, 200WD, 200RTD, 200C9D, 200TVD)*

2"	90 Foot Pounds
2-1/2"	90 Foot Pounds
3"	90 Foot Pounds
4"	90 Foot Pounds
6"	90 Foot Pounds
8"	141 Foot Pounds
10"	141 Foot Pounds
12"	141 Foot Pounds

### 100 Series Cast Iron Valves

*(Includes 100M, 100W, 105W)*

14"	290 Foot Pounds
16"	361 Foot Pounds

## Valve Disassembly- Packing Box (Stuffing Box)

If a valve begins leaking at the top of the packing box, near the stem, it is likely the result of a cracked or cut o-ring. The solution is to open the packing box (stuffing box) area and replace the o-rings by following the instructions below. This function can be performed with the valve under pressure with the wedge in a **FULLY OPEN POSITION**. Do not be alarmed if some seepage takes place after unbolting the packing box. See Table 5 for wrench size needed to perform this function.

- a. Remove the top bolt holding down the operating nut or handwheel.
- b. Remove the operating nut or handwheel.
- c. On 200M and 200MD valves remove the protective (hot melt) wax covering the packing box (stuffing box) bolts.
- d. Remove the packing box (stuffing box) bolts.

- e. Lift off the packing box (stuffing box) and replace the o-rings and packing box (stuffing box) gasket.
- f. Reassemble in reverse order making sure the packing box (stuffing box) gasket is securely in place.
- g. Tighten bolts to recommended torques in Table 6.

### **Table 5- Packing Box (Stuffing Box) Bolt Size**

**200 Series Cast Iron Valves**

*(Includes 200M, 200W, 200FJ, 100RT)*

2"	8 mm Allen Wrench
2-1/2"	8 mm Allen Wrench
3"	8 mm Allen Wrench
4"	8 mm Allen Wrench
6"	10 mm Allen Wrench
8"	10 mm Allen Wrench
10"	14 mm Allen Wrench
12"	14 mm Allen Wrench

**200D Series Ductile Iron Valves**

*(Includes 200MD, 200WD, 200RTD, 200C9D, 200TVD)*

2"	8 mm Allen Wrench
2-1/2"	10 mm Allen Wrench
3"	10 mm Allen Wrench
4"	10 mm Allen Wrench
6"	14 mm Allen Wrench
8"	14 mm Allen Wrench
10"	14 mm Allen Wrench
12"	14 mm Allen Wrench

**100 Series Cast Iron Valves**

*(Includes 100M, 100W, 105W)*

14"	3/4"
16"	3/4"

**Table 6- Packing Box (Stuffing Box) Bolt Torques**

**200 Series Cast Iron Valves**

*(Includes 200M, 200W, 200FJ, 100RT)*

2"	59 Foot Pounds
2-1/2"	59 Foot Pounds
3"	59 Foot Pounds
4"	59 Foot Pounds
6"	89 Foot Pounds
8"	89 Foot Pounds
10"	133 Foot Pounds
12"	133 Foot Pounds

**200D Series Ductile Iron Valves**

*(Includes 200MD, 200WD, 200RTD, 200C9D, 200TVD)*

2"	60 Foot Pounds
2-1/2"	60 Foot Pounds
3"	60 Foot Pounds
4"	60 Foot Pounds
6"	91 Foot Pounds
8"	91 Foot Pounds
10"	135 Foot Pounds
12"	135 Foot Pounds

**100 Series Cast Iron Valves**

*(Includes 100M, 100W, 105W)*

14"	217 Foot Pounds
16"	217 Foot Pounds

# 200WW Cast Iron Gate Valve • Spec Sheet

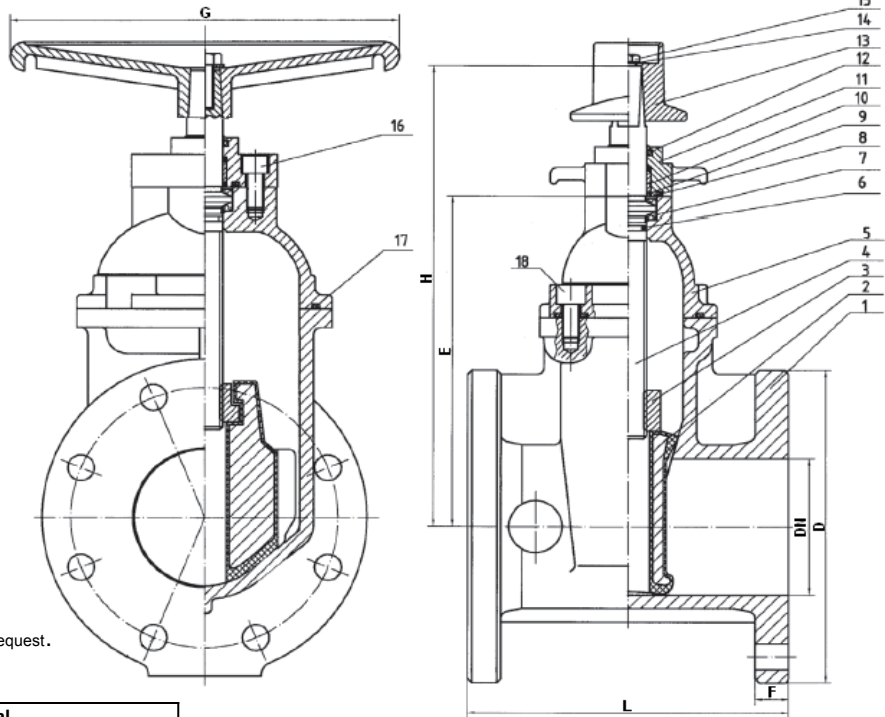

\* Valve comes standard with wheel handle . 2" Op Nut available upon request.

## MATERIAL SPECIFICATIONS

No	Part	Material
1	Valve Body	Cast Iron ASTM A126-B
2	Resilient Wedge	Ductile Iron ASTM A536/ EPDM ASTM D2000
3	Stem Nut	Bronze ASTM B584
4	Stem	Stainless Steel AISI 410
5	Bonnet	Cast Iron ASTM A126-B
6	Stem Primary O-Ring	EPDM ASTM D2000
7	Stem Gasket	NYLON 1010
8	Gland Seal O-Ring	EPDM ASTM D2000
9	Stem Secondary O-Ring	EPDM ASTM D2000
10	Stem Seal Bushing	NYLON 1010
11	Packing Gland	Ductile Iron ASTM A536
12	Wiper Ring	EPDM ASTM D2000
13	Operating Nut	Cast Iron ASTM A126-B
14	Washer	Stainless Steel AISI 410
15	Bolts	Stainless Steel AISI SS304
16	Gland Bolts	Stainless Steel AISI SS304
17	Bonnet Gasket	EPDM ASTM D2000
18	Bonnet Bolt	Stainless Steel AISI SS304

## FEATURES & BENEFITS

- Gate Valve - Flanged Ends
- 200 CWP - Max Temp. 230° F.
- Fusion Epoxy Coating - AWWA C550
- Resilient Wedge
- Non Rising Stem
- Meets AWWA C-509 Standard
- Flanged End Conforms with ANSI B16.1

## APPLICATIONS

Potable Water, Irrigation, Turf, Sewage Disposal, Golf Course, Water Distribution Service and Feed Lines.

## DIMENSIONS

Size (DN)	L	F	D	E	H	G
2"	7.00	0.63	6.00	6.30	10.80	7.88
3"	8.00	0.75	7.50	8.35	12.85	10.24
4"	9.00	0.95	9.00	9.69	14.18	10.24
6"	10.50	1.00	11.00	13.00	17.61	14.78
8"	11.50	1.13	13.50	16.15	20.92	14.78
10"	13.00	1.19	16.00	13.00	17.61	15.76
12"	14.00	1.26	19.00	16.15	20.92	19.70



**MATCO-NORCA**

Global sourcing. National compliance. Local service.

**CALIFORNIA** 5593 Fresca Dr., La Palma CA 90623 • Toll Free: 866-532-8306 • Fax: 866-532-8307  
**TEXAS** 1150 Silber Rd., Houston TX 77055 • Toll Free: 800-935-5456 • Fax: 713-680-2999  
**NEW YORK** PO Box 27, Rt. 22, Brewster NY 10509 • Toll Free: 800-431-2082 • Fax: 845-278-9056  
 WEB: [www.matco-norca.com](http://www.matco-norca.com) EMAIL: [mail@matco-norca.com](mailto:mail@matco-norca.com)

# 200MD Ductile Iron Gate Valve • Spec Sheet



## FEATURES & BENEFITS

- Ductile Iron Body
- Resilient Wedge
- Mechanical Joint Ends
- Fusion Epoxy Coated - AWWA C550
- Non Rising Stem
- 250 CWP
- Meets AWWA C-515 standard
- Mechanical Joint Ends Conform with AWWA C111/A21.11
- Sizes 2" - 12"

## APPLICATIONS

Potable Water, Water Distribution Services & Feed Lines,  
Sewage Disposal, Irrigation, Turf, Golf Course

## DIMENSIONS

Size	Part #	L	D2	D1	D	G	H	Bolt Circle	Qty x Dia Bolt Hole	Approx. WT. LBS
2"	200MD08	8.6	6.30	3.5	2.68	.59	9.85	4.88	2 x .75	28
3"	200MD10	8.0	7.62	4.9	4.06	.59	12.46	6.19	4 x .75	44
4"	200MD11	9.0	9.12	6.0	4.94	.60	13.35	7.50	4 x .88	69
6"	200MD13	10.5	11.06	8.1	7.11	.63	16.57	9.50	6 x .88	119
8"	200MD14	11.5	13.31	10.3	9.16	.66	20.75	11.75	8 x .88	203
10"	200MD15	13.0	15.62	12.3	11.21	.70	24.33	14.00	8 x .88	278
12"	200MD16	14.0	17.88	14.4	13.31	.73	27.56	16.25	8 x .88	421

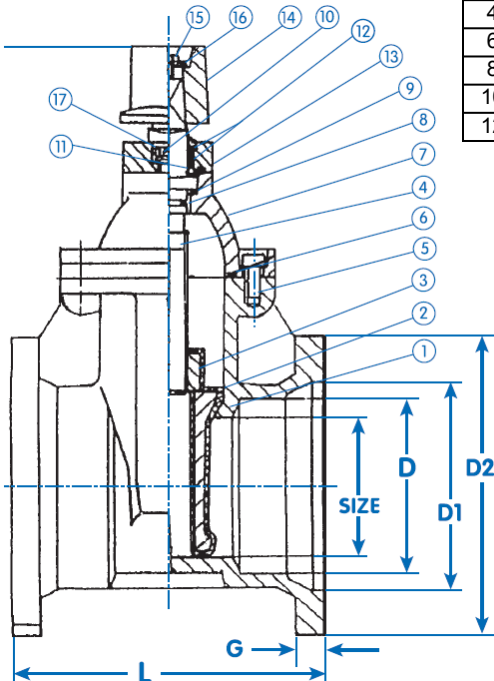

Enlarged Drawing On Page 2  
(Click Here)

## MATERIAL SPECIFICATIONS

No.	Part	Material	ASTM Designation
1	Body	Ductile Iron	A536 65/45/12
2	Disc	Ductile Iron Rubber Encapsulated	A536 65/45/12 / BUNA-N
3	Stem Nut	Bronze	B584 UNS C83600
4	Stem	Stainless Steel	AISI 410 UNS S41000
5	Bonnet Bolt	Stainless Steel	GR 304
6	Bonnet Gasket	BUNA-N	Commercial
7	Bonnet	Ductile Iron	A536 65/45/12
8	Split Ring	Brass	B16 UNS C36000
9	Thrust Washer	Stainless Steel	GR 304
10	Packing Box Bolt	Stainless Steel	GR 304
11	Packing Box Gasket	BUNA-N	Commercial
12	O-Rings	BUNA-N	Commercial
13	Packing Box	Ductile Iron	A536 65/45/12
14	Operating Nut	Ductile Iron	A536 65/45/12
15	Top Bolt	Stainless Steel	GR 304
16	Washer	Stainless Steel	AISI 410 UNS S41000
17	Wiper Ring	BUNA-N	Commercial



# MATCO-NORCA

Global sourcing. National compliance. Local service.

# 200MD Ductile Iron Gate Valve • Spec Sheet

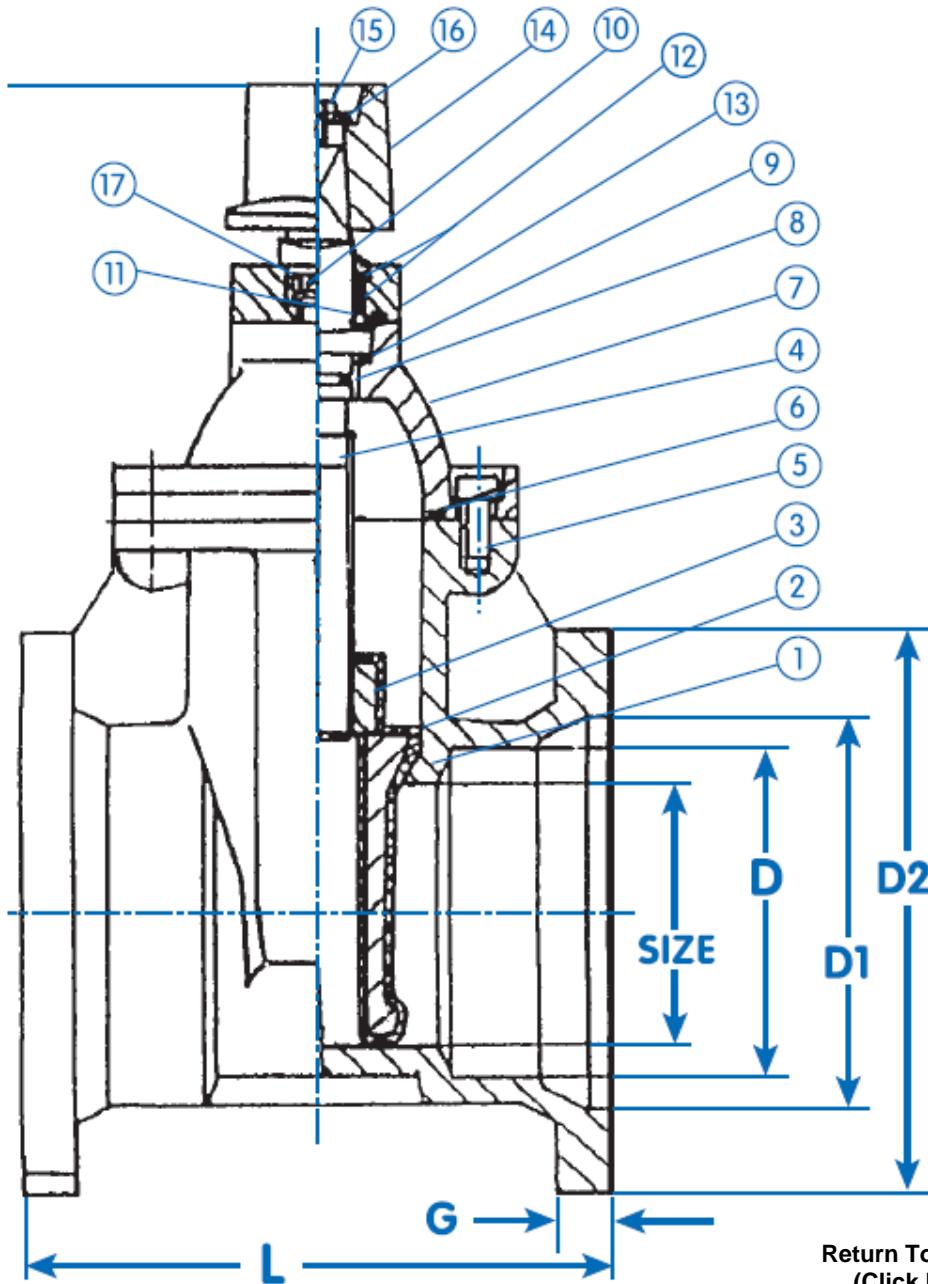

[Return To Page 1  
\(Click Here\)](#)

 **MATCO-NORCA**  
Global sourcing. National compliance. Local service.

**CALIFORNIA** 5593 Fresca Dr., La Palma CA 90623 • Toll Free: 866-532-8306 • Fax: 866-532-8307  
**TEXAS** 1150 Silber Rd., Houston TX 77055 • Toll Free: 800-935-5456 • Fax: 713-680-2999  
**NEW YORK** PO Box 27, Rt. 22, Brewster NY 10509 • Toll Free: 800-431-2082 • Fax: 845-278-9056  
WEB: [www.matco-norca.com](http://www.matco-norca.com) EMAIL: [mail@matco-norca.com](mailto:mail@matco-norca.com)

# 200MD Ductile Iron Gate Valve • Spec Sheet

## Valve Closure Wheel Rotation Specification for 200MD, WD & RTD Series Gate Valves

The following table notes how many Stem/Wheel rotations are required to completely open or close the 200MD/WD&RTD Series Valves.

Valve Size	Turns to Shut Off
2"	7
2-1/2"	9
3"	10
4"	13
6"	15
8"	17
10"	21
12"	25



# 100M AWWA C509 CAST IRON GATE VALVE



- ❖ Resilient Wedge ❖ MJ x MJ Ends Per AWWA C111/A21.11
  - ❖ Non Rising Stem ❖ Bolted Bonnet ❖ Fusion Bonded Epoxy Coated
- 150 PSI Non-Shock CWP\*      MAXIMUM TEMPERATURE 140°F**

Applications: Potable Water, Turf Irrigation, Golf Course, Water Distribution Service & Feed Lines, Sewage Disposal

Product Specs Sheet



ISO 9001:2000

## DIMENSIONS & WEIGHTS

SIZE dØ INCH	L	DØ	CØ	hØ	n	T	SØ*	H	APROX. WT. LBS.
14	15	20.31	18.75	.88	10	1.31	1.40	35.62	738
16	16	22.56	21.00	.88	12	1.38	1.56	39.38	942

\*SØ Measurement taken at base of thread.

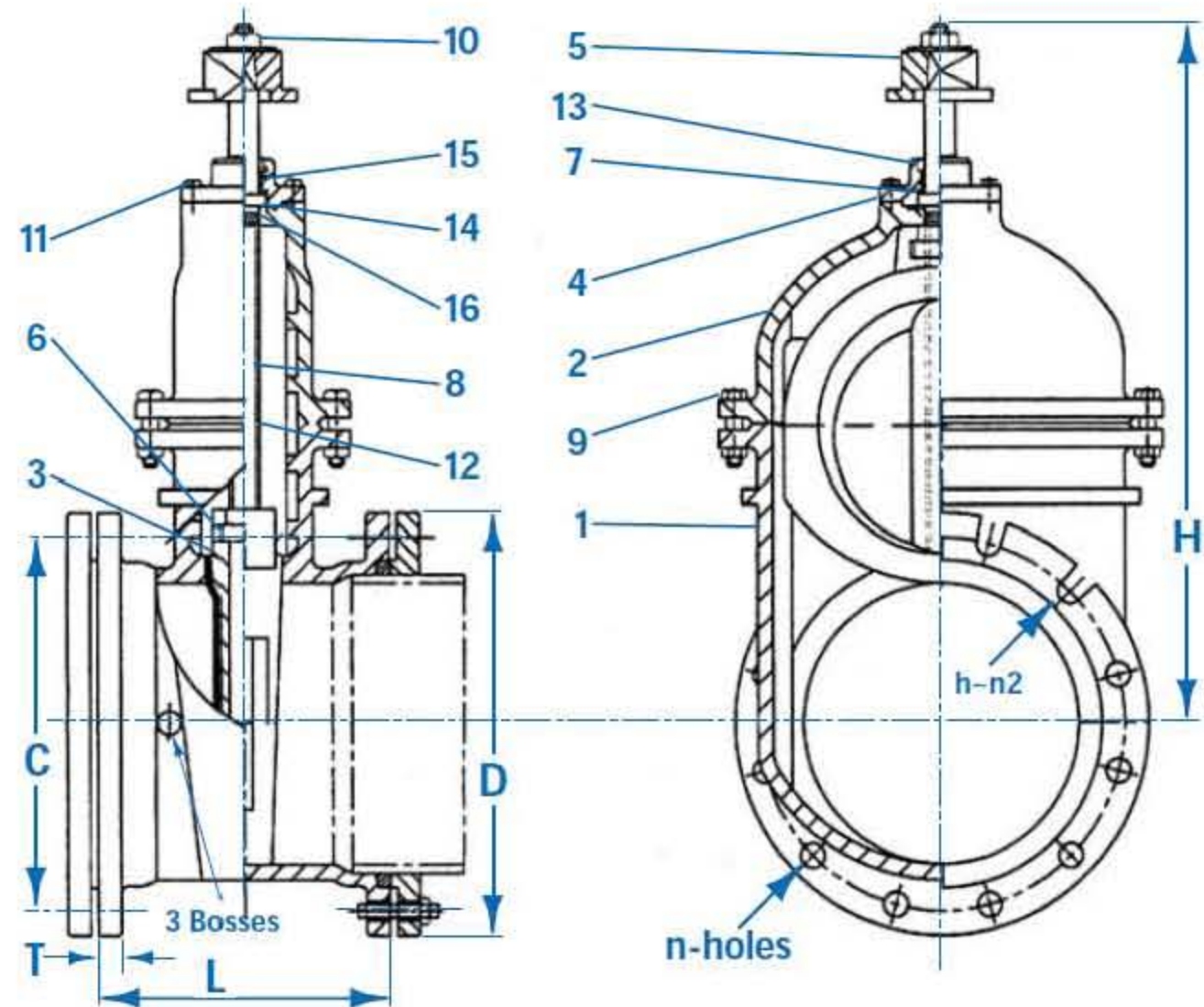

## MATERIAL SPECIFICATIONS

NO. PARTS	MATERIAL	ASTM DESIGNATION	NO. PARTS	MATERIAL	ASTM DESIGNATION
1 Body	Cast Iron	A126 Class B	9 Bonnet, Bolt & Nut	Zinc Coated Steel	A307 Grade B
2 Bonnet	Cast Iron	A126 Class B	10 Top Nut	Zinc Coated Steel	A307 Grade B
3 Disc	Cast Iron & Rubber (BUNA N)	A126 Class B & D2000 BK707	11 Stuffing Box, Bolt	Zinc Coated Steel	A307 Grade B
4 Stuffing Box	Cast Iron	A126 Class B	12 Bonnet Gasket	Rubber (BUNA N)	D 2000 BK 707
5 Operating Nut	Cast Iron	A126 Class B	13 Wiper Ring	Rubber (BUNA N)	D 2000 BK 707
6 Stem Nut	Bronze	B62	14 O-Ring A	Rubber (BUNA N)	D 2000 BK 707
7 Washer	Bronze	B21	15 O-Ring B	Rubber (BUNA N)	D 2000 BK 707
8 Stem	Bronze	B21	16 O-Ring C	Rubber (BUNA N)	D 2000 BK 707

