

# Exhibit 6030 IFS Acrylic Alcove Bathtub

**Model number:**

105519-000-001-102

**Dimensions:** 59.75" x 30" x 17.75"

**Installation:** Alcove

**Material:** Acrylic

## Standard Features:

- Alcove bathtub
- Acrylic surface resistant to stains
- Available in white, bone or biscuit color to complement any bathroom decor
- Available in left-hand and right-hand drain configurations to fit your specific bathroom layout
- Integrated tiling flange for added leak protection and easy installation of shower walls

## Product characteristics:

- Elegant Design
- Integrated Tiling Flange and Skirt
- Integrated Tiling Flange and Skirt

## Systems:

Whirlpool  
Combined Whirlpool/Aeroeffect  
Aeroeffect

Certifications

MAAX products adhere to one or more of the following certifications:

## Standard Colors:

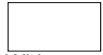

White



Bone



Biscuit



# MAAX

# Exhibit 6030 IFS Acrylic Alcove Bathtub

**Model number:**

105519-000-001-102

**Dimensions:** 59.75" x 30" x 17.75"

**Installation:** Alcove

**Material:** Acrylic

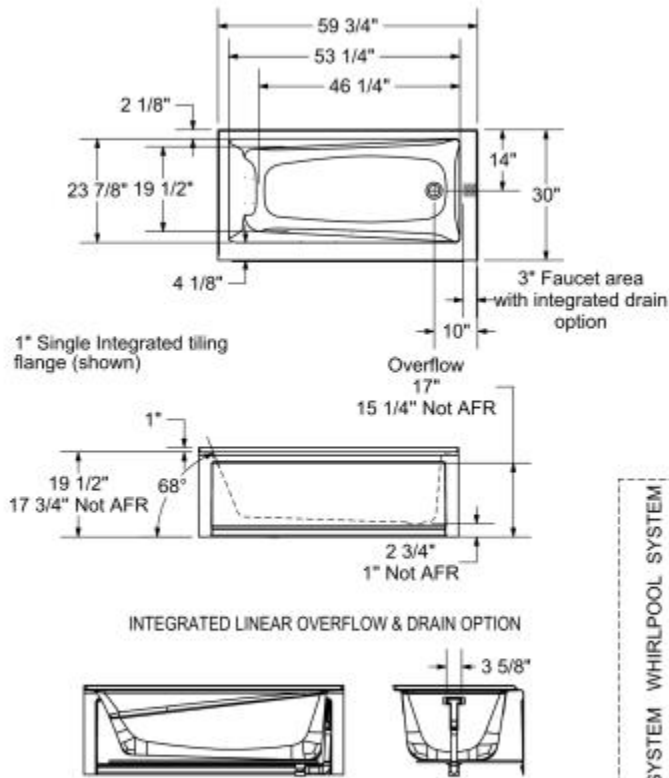

Wood support design may vary.  
Single integrated tiling flange: 1" height x 1/4" thickness (shown)  
All dimensions are approximate. Structure measurements must be verified against the unit to ensure proper fit.

WITHOUT SYSTEM



WITH SYSTEM

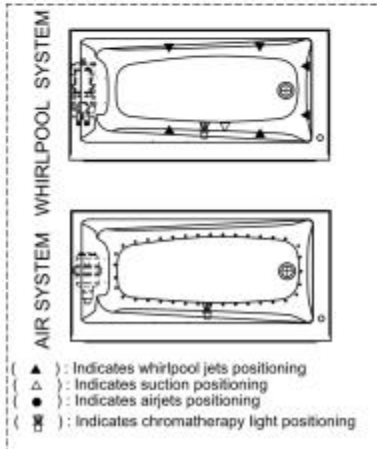
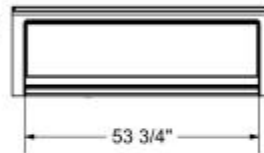

## Dimensions

59 3/4 x 30 x 17 3/4 In.  
(1518 x 762 x 451 mm)

## Water Capacity

44 gallons - 168 liters

## Weight

77 lbs - 35 kg

## Bathing Well

59 3/4 In. x 24 In.  
(1518 mm x 606 mm)

## Deep Sump Height

16.5 In. - 419 mm

## Deck Width

4.125 In. - 105 mm

## Drain location:

Left

Right

Project: \_\_\_\_\_

Contractor: \_\_\_\_\_

Representative: \_\_\_\_\_

Date: \_\_\_\_\_

Tel: \_\_\_\_\_

Notes: \_\_\_\_\_

# MAAX