

ASCENT™ II

Macerating Toilet System

Liberty Pumps®

A Family and Employee Owned Company

Featuring RazorCut™ Technology IST™ Switch Sensing and CleanConnect™ Seal

Ascent™ II

Macerating Toilet System

The complete system for convenient addition of a bathroom in remodeling projects and additions. Powerful macerating system pumps waste to existing sewer lines in the building or home—*up to 25' high and 150' horizontally. Accepts additional lavatory and tub/shower connections for a complete bathroom anywhere!

*Horizontal distance can vary with amount of vertical pumping head. Consult factory for additional sizing and performance information.

Performance

Powerful and quiet, the RazorCut™ system with stainless steel blades provides superior cutting compared to other macerating toilets.

Appearance

Clean, compact, and modular. The CleanConnect™ Seal system eliminates unsightly rubber couplers for connecting the toilet to the macerator unit. Rear exiting discharge and vent connectors conceal piping when exiting directly to a wall.

Serviceability

Designed with a removable access cover, the Ascent™ II is completely serviceable without removing the macerating unit from the toilet or disconnecting plumbing!

Functionality

LEDs inform of power ON, alarm condition, and low battery condition. Touchpad buttons allow manual by-pass operation of the unit and alarm silencing.



Patent: See
www.LibertyPumps.com/patents



Toilet complies with ADA standard ICC/ANSI A117.1 and CSA B651.



Toilet IAPMO Listed ASME A112.19.2/CSA B45.1

Toilet EPA WaterSense Listed for 1.28 gallon per flush (gpf) requirements



Macerator CSA Certified and IAPMO Listed to ASME A112.3.4 and CSA B45.9.

innovate. evolve.

Ascent™ II



Patent: See www.LibertyPumps.com/patents

Macerator Features

- RazorCut™ system features heavy-duty stainless steel blades
- Advance run technology assures macerator blades are running prior to debris entering the cutter basket
- IST™ Intelligent Switch Technology provides for complete flush-out of debris in the cutter area reducing potential clogging and jamming
- Solid-state electronic switch system provides intelligent data for system operation and eliminates older style mechanical or diaphragm switches
- Auxiliary inlets on each side of unit allow for connection of a lavatory and/or shower. White couplers. Accepts 1-1/2" or 2" pipe
- Built-in alarm with 9-volt battery backup and push-to-silence switch
- LEDs inform of power ON, alarm condition, and low battery condition
- Contoured tank design allows for wall molding to run behind macerator unit

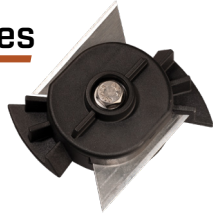

Horizontal or Vertical Piping?

QuickFlip™ discharge and vent connectors allow for horizontal or vertical pipe connections. Simply unscrew the connector and rotate 180 degrees for optional connection.

Heavy-duty connectors are PVC solvent weld type

1" discharge with integral check valve (can be reduced to 3/4")

1-1/2" vent

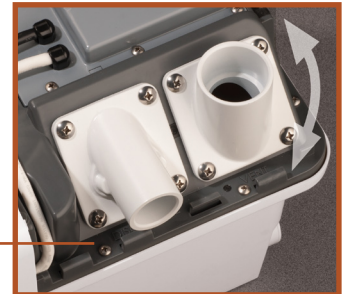
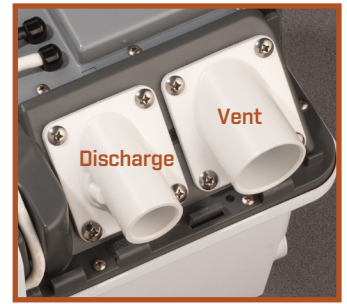

Cord management system allows for hidden storage of excess power cord under the cover. No more cinched or twist-tied cable loops hanging outside the system! An 8' white power cord is provided. Cord can be routed under the cover to exit either the left or right side!

Removable Service Panel



Integral heavy-duty rubber gaskets



Removable service panel on top cover provides easy access to system without removing plumbing or disconnecting the macerator from the toilet. No tools required.

RazorCut™ system is accessible for cleaning or blade replacement. Safety shut-off automatically disconnects electrical power when access cover is removed.

IST™ Intelligent Switch Technology

The Ascent™ II features solid-state switch technology. Strategically located sensors activate the pump and alarm eliminating the need for troublesome diaphragm or mechanical float switches.

LED display:

Power ON • Alarm condition • Low battery condition

Functional touchpad on top of unit features:

- **Push to Run override** – allows manual run of the macerator overriding the IST™ switch
- **Push to Silence switch** – silences the alarm

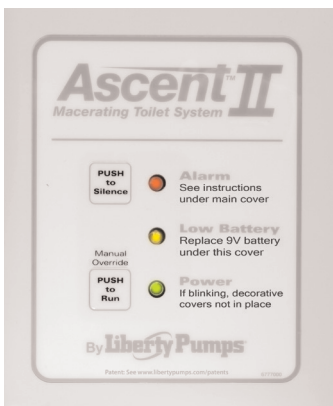

Macerator CSA Certified and IAPMO Listed to ASME A112.3.4 and CSA B45.9.

Qualifies with CSA B651 when installed with trip lever on approach side and flush actuation force of less than 5 lbs.

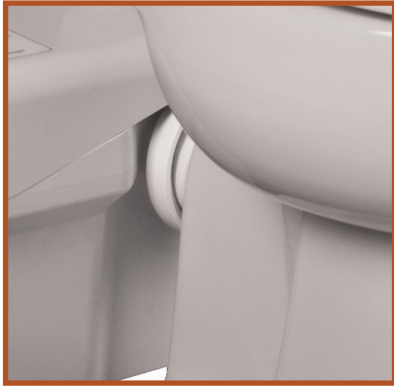

CleanConnect™ Seal eliminates unsightly rubber accordion style couplers and hose clamps for connection of toilet to the macerator unit! Simply slide the macerator unit with a robust integral seal onto the hub of the toilet. Macerator sits closer to toilet for a more professional appearance!

Specifications

Hp: 1/2

Volts: 115

Hz: 60

Amps: 7.9

RPM: 3450

Thermally protected with automatic reset

Alarm: 115V with 9-volt battery backup (battery included)

Tank Material: ABS

Cutter Blades: Stainless Steel 440A hardened to Rockwell 54c

Power Cord: 18-3, 8', white, right-angle plug holds close to wall

Maximum Fluid Temperature: 104°F, 40°C

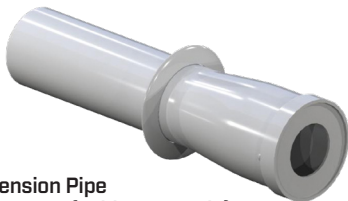

Extension Pipe

#K001184 (sold separately)

Includes decorative trim ring for a more professional looking installation. 18" length works with 2" x 4" or 2" x 6" wall.

Toilet Features

- Round or Elongated styles available
- ADA bowl height compliant
- HET (High Efficiency Toilet) 1.28 gpf (4.85 lpf)
- Improved flush design for one-flush operation
- White finish
- Installed flush valve kit
- 2-3/4" Trap
- Slow-close toilet seat included with complete system
- Insulated tank eliminates sweating in extreme climates



Performance

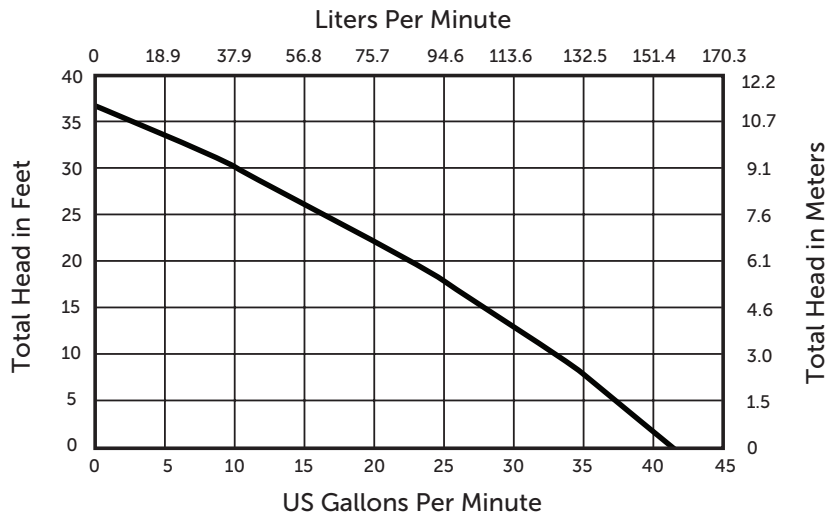

Note: Maximum shut-off head is 36'. Usable maximum head - assuming 150' of lateral discharge through 1"-pipe is 25'. Consult factory for proper sizing and calculation of friction loss.

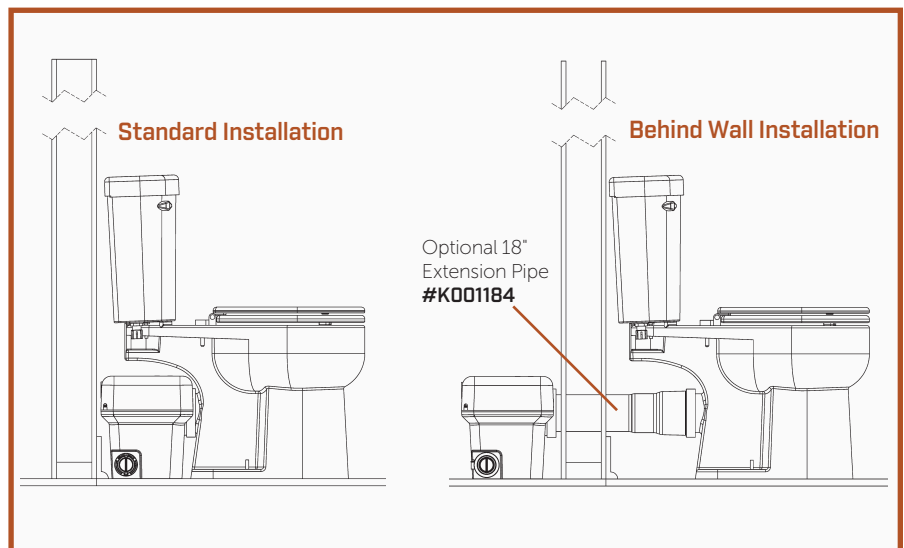

Dimensional Data

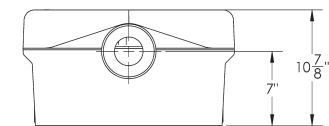
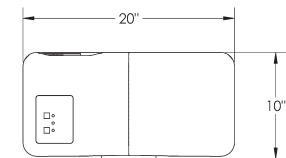
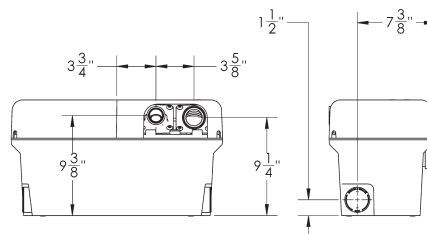
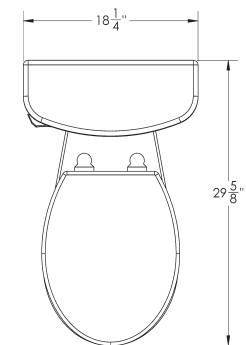
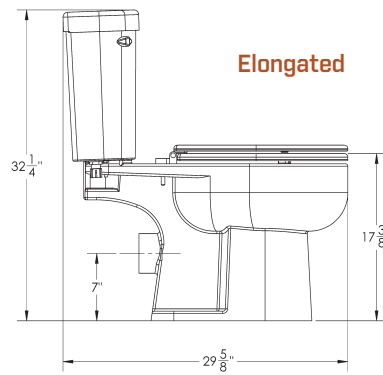
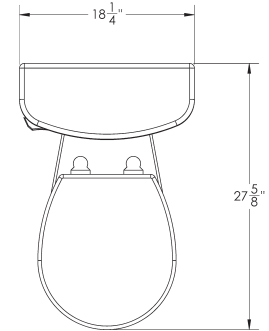
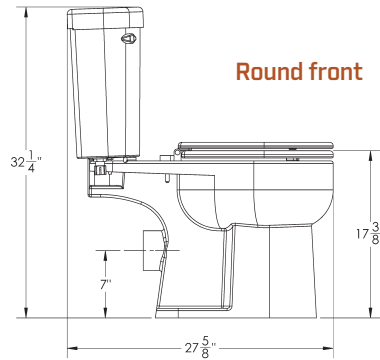

MODEL	DESCRIPTION	WEIGHT
ASCENTII-ESW	Complete system: macerator and elongated toilet - white	121 lbs
ASCENTII-RSW	Complete system: macerator and round front toilet - white	115 lbs
ASCENTII-MUW	Macerator unit only	22 lbs
ASCENTII-TW	Toilet tank and lid, insulated with flush valve kit - white	34 lbs
ASCENTII-EW	Toilet bowl, elongated - white (bowl only)	49 lbs
ASCENTII-RW	Toilet bowl, round front - white (bowl only)	45 lbs
K001184	Extension pipe, 4" x 18" with integral seal and trim ring	3 lbs