



2020 PRODUCT GUIDE





TABLE OF CONTENTS

THE K-RAIN® STORY	01	IRRIGATION CONTROLLERS	
IRRIGATION SOLUTIONS	03	Pro LC	41
ROTORS		Pro Ex 2.0 WiFi	42
MiniPro®	04	Pro Ex 2.0	44
RPS™ 50	06	BL-24	46
RPS™ 75	08	BL-KR	47
RPS™ 75i	10	TC-KR	48
RPS™ Select	12	RPS™ 46	49
SuperPro®	14	RPS™ 624	50
ProPlus®	16	Rain Sensor	51
ProSport®	18	PUMP START RELAYS	
SPRAYS		Pump Start Relays	52
Pro-S™	20	SINGLE STATION CONTROLLER	
NP Sprays	22	Single Station Controller	53
K-Sprays	23	INDEXING VALVES	
NOZZLES		4000 Series Indexing Valve	54
Rotary Nozzle Series	24	6000 Series Indexing Valve	55
Fully Adjustable Rotary Nozzles	26	RECLAIMED WATER (RCW)	
High Efficiency KVF Nozzles	28	ProPlus® RCW	56
KV Nozzles	30	RCW Series	57
Fixed Nozzles	32	ACCESSORIES	
DRIP, BUBBLERS		Accessories	58
PC Dripline System	34	CHARTS	60
Tree Bubblers	35	DESIGN RESOURCES	72
ELECTRIC VALVES		WARRANTY	73
ProSeries 100 Valves	36		
ProSeries 150 Valves	38		
ProSeries 200 Valves	40		

The K-Rain® Story

Incorporated in 1974, K-Rain® Manufacturing started on the path to become one of the largest manufacturers of irrigation rotors, sprays, valves and controllers in the world.

The Early Years

As a young man, Carl Kah excelled in physics and chemistry and had a keen interest in electronics and aerodynamic design. While still in high school, he designed and built an early version of a cyclone vacuum cleaner. It would be the first of many inventions to come.

From Rockets to Rotors

With a degree in Chemical Engineering and after graduating first in his class from the U.S. Army Artillery Corps Guided Missile School, Carl began work in the Applied Research and Propulsion Division of Pratt & Whitney. His contribution there helped develop the early reusable rocket engines – a technology that is still used by NASA today.

In the evenings, out of concern for his own residential lawn, he used a lathe in his garage to design and machine a valve that cycled from zone to zone thus eliminating the need for multiple valves. Carl patented the valve in 1966.

In 1970, he invented and patented the Modulated Pressure Control. This allowed for the control of the entire irrigation system of a golf course without wires or tubes. The patent was later sold to a manufacturer of golf course irrigation systems. That patent sale was the catalyst to founding K-Rain® Manufacturing.

It's a Family Affair

Twelve years later in 1986, Carl's son Chip joined the business and led the development and growth of indexing valves for the wastewater disposal industry. And as early as 1991, K-Rain® introduced its first gear drive sprinkler. By 1993, Chip would be at the helm as president of the company.

1995 was a new turning point for the company. K-Rain® began expanded their products to retail and Carl's two daughters, Gretchen and Deb joined the family business. Gretchen would eventually lead the west coast sales division. Deb, an attorney, would be managing intellectual property and human resources.

Christopher Kah, Chip's oldest son, joined the business in 2016 and as recently as 2017 son Trevor officially came on board making it three generations driving the company.



A young Carl Kah working with a lathe

Engineering First

K-Rain® has always been an “engineering first” environment, continually seeking to pair ease-of-use with industry-leading technology. The commitment to quality has led the company to an ISO9001 quality certification in 2006. ISO is the quality standard for manufacturing and process control.

Carl himself holds over 80 patents specific to the irrigation industry including the three-spring reversing mechanism still used today in most gear driven sprinklers. He continues to use his engineering expertise and creativity to further develop innovative technology.

Sustainability is one of the top priorities at the company with a full range of products for reclaimed/recycled water. “Doing our part for a greener future is just part of our DNA,” says Adrian Toribio, Director of Operations and Quality. “We’re environmentally conscious about the materials we select and ensuring our manufacturing processes are highly energy efficient as well.”

K-Rain® persists in leading the industry globally with new developments in rotor and nozzle engineering. “Our RPS™ 75i with Intelligent Flow Technology® is the only rotor of its type to significantly reduce water waste by regulating flow and distance proportionately and simultaneously,” notes Chip. “Also, the RPS™ Select is another unique rotor with 4 built-in nozzles—select the pattern and select the equivalent nozzle for matched precipitation. And in the past few years, we’ve introduced new items such as blue tooth controllers for use with smart phones and WiFi enabled controllers.”

Today

Over 300 men and women make up the K-Rain® team, serving customers in the United States and more than 60 countries worldwide. Beyond any technical advancement, people are at the heart of all we do. Every day we go to work with one thought: Make it better.



The right products for every landscape.

IRRIGATION SOLUTIONS

for Residential, Multi-family, Institutional and Commercial Properties

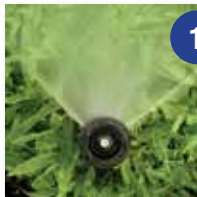
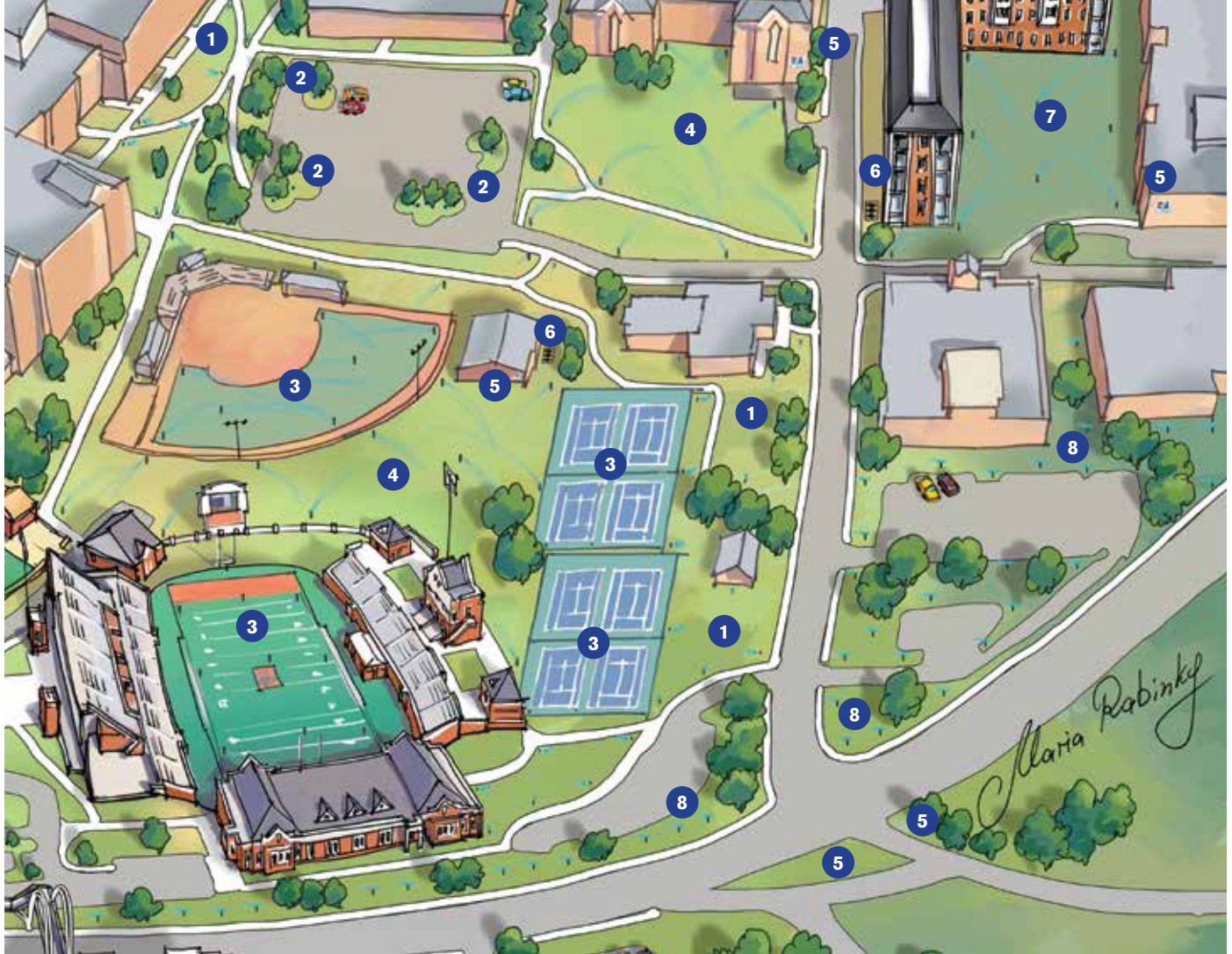

1 Pro-S™ 1/2" Inlet Spray Bodies



4 3/4" Gear Drive Rotors



7 MiniPro® 1/2" Gear Drive Rotor



2 Shrub & Tree Bubblers



5 Irrigation Controllers, Bluetooth & Wifi



8 High Efficiency Rotary Nozzles

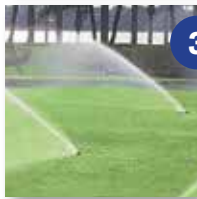

3 ProSport® 1" Gear Drive Rotor



6 Electric Valves

K-Rain® also offers:

Fixed and Adjustable Nozzles, Bubblers, RCW Products, PC Dripline Systems, Pump Start Relays, Rain Sensors & More.

MINIPRO®

Application: Residential / Commercial

Perfect for small lawn and landscape areas and for replacing fixed spray zones.

When considering the industry leading MiniPro® gear driven rotor, think water efficiency.

Now available in three popular heights and compatible with a wide selection of nozzles, the MiniPro® brings flexibility to system design.



Easy Arc Setting

Arc Selection 40° to 360°
Adjust From Left Start

Features and Benefits

- **Revolutionary Patented Top Arc Set** – Simplified arc set allows for wet or dry adjustment in seconds.
- **1/2" (1,3 cm) Inlet** – Replaces all standard mini rotors and pop-up sprays.
- **Adjustable to 360°** – Provides a full range of adjustment from 40° to 360°.
- **Patented Top Arc Set Degree Markings** – Clearly indicates the current watering pattern and simplifies arc set adjustment.
- **Time Proven Patented Reversing Mechanism** – Assures continuous reverse and return...over a 35 year history.
- **Ratcheting Riser** – Allows for easy adjustment of your left starting position with a simple turn of the riser.
- **Rubber Cover** – Seals out dirt and increases product durability.
- **Wide Selection of Nozzles** – Provides flexibility in system design.
- **Optional Check Valve** – Prevents low head drainage.



Performance Data

NOZZLE	PRESSURE			RADIUS		FLOW RATE			PRECIP in/hr		PRECIP mm/hr	
	PSI	kPa	Bars	Ft.	M.	GPM	L/M	M ³ /H	■	▲	■	▲
#0.75	30	207	2,07	18'	5,5	0.8	2,8	0,17	.45	.51	11	13
	40	276	2,76	19'	5,8	0.8	3,0	0,18	.43	.49	11	13
	50	345	3,45	20'	6,1	0.9	3,4	0,20	.43	.50	11	13
#1.0	30	207	2,07	26'	7,9	0.9	3,4	0,20	.26	.30	7	8
	40	276	2,76	27'	8,2	1.2	4,5	0,27	.32	.37	8	9
	50	345	3,45	27'	8,2	1.3	4,9	0,30	.34	.40	9	10
#1.5 Pre-installed	30	207	2,07	27'	8,2	1.5	5,7	0,35	.34	.40	9	10
	40	276	2,76	27'	8,2	1.8	6,8	0,41	.32	.37	8	9
	50	345	3,45	28'	8,5	2.0	7,6	0,46	.34	.39	9	10
#2.0	30	207	2,07	29'	8,8	2.0	7,6	0,46	.39	.44	10	11
	40	276	2,76	30'	9,1	2.3	8,7	0,53	.42	.49	11	12
	50	345	3,45	31'	9,4	2.7	10,2	0,62	.42	.49	10	12
#3.0	30	207	2,07	32'	9,8	3.0	11,4	0,69	.48	.55	12	14
	40	276	2,76	33'	10,1	3.4	12,9	0,78	.45	.51	11	13
	50	345	3,45	33'	10,1	3.8	14,4	0,87	.52	.60	13	15

*All precipitation rates calculated for 180° operation. For the precipitation rate for a 360° sprinkler, divide by 2.

Specifications

- Inlet: 1/2" (1,3 cm) Threaded NPT
- Arc Adjustment Range: 40° – 360°
- Flow Range: 0.8 – 3.3 GPM (3 – 12,5 LPM)
- Pressure Rating: 20 – 70 PSI (1,4 – 4,8 bar)
- Precipitation Rate: .26 – .60 in/hr (6,6 – 15,24 mm/hr)
(Depending on Spacing and Nozzle Used)
- Overall Height (Popped Down): 4", 6", 12"
(12,2 cm, 15,2 cm, 30,5 cm)
- Recommended Spacing: 17' – 34' (5,2 – 10,4 m)
- Radius: 18' – 33' (5,5 – 10,1 m)
- Nozzle Trajectory: 25°
- Riser Height: 4", 6" or 12" (12,2 cm, 15,2 cm, 30,5 cm)

Models

- 13003** MiniPro® – 4" (10,2 cm)
- 13006** MiniPro® – 6" (15,2 cm)
- 13012** MiniPro® – 12" (30,5 cm)

OTHER OPTIONS: ADD TO PART NUMBER

- CV Check Valve
- NN No Nozzle
- RCW Reclaimed Water Use





RPS™ 50

Application: Residential / Commercial



Designed for smaller areas, the RPS™ 50 is available with a wide selection of nozzles that bring flexibility to system design.

The RPS™ 50 is a gear-driven, rotary sprinkler, capable of covering an area of 18' to 36' (5,5 to 11 M) radius at nozzle pressure of 30 to 50 PSI (2,1 to 3,4 bar) with a discharge rate of .8 to 3.3 GPM (2,8 to 12,5 LPM).

The RPS™ 50 is supplied with five (5) numerically coded interchangeable nozzles. Sprinkler nozzle trajectory is 25°.

The sprinkler has a stainless steel radius adjustment screw and has arc adjustment from 40° to 360°.



Easy Arc Setting

Arc Selection 40° to 360°
Adjust From Right Start

Features and Benefits

- **Right Position Start** – Rotor rotates counterclockwise from fixed right start position.
- **Time Proven Patented Reversing Mechanism** – Assures continuous reverse and return... over a 35 year history.
- **Ratcheting Riser** – Allows for easy adjustment of your right starting position with a simple turn of the riser.
- **Rubber Cover** – Seals out dirt and increases product durability.
- **Wide Selction of Nozzles** – Provides flexibility in system design.
- **Optional Check Valve** – Prevents low head drainage.

Performance Data

NOZZLE	PRESSURE			RADIUS		FLOW RATE			PRECIP in/hr		PRECIP mm/hr	
	PSI	kPa	Bars	Ft.	M.	GPM	L/M	M ³ /H	■	▲	■	▲
#0.75	30	207	2,07	18'	5,5	0.8	2,8	0,17	.45	.51	11	13
	40	276	2,76	19'	5,8	0.8	3,0	0,18	.43	.49	11	13
	50	345	3,45	20'	6,1	0.9	3,4	0,20	.43	.50	11	13
#1.0	30	207	2,07	26'	7,9	0.9	3,4	0,20	.26	.30	7	8
	40	276	2,76	27'	8,2	1.2	4,5	0,27	.32	.37	8	9
	50	345	3,45	27'	8,2	1.3	4,9	0,30	.34	.40	9	10
#1.5 Pre-installed	30	207	2,07	27'	8,2	1.5	5,7	0,35	.34	.40	9	10
	40	276	2,76	27'	8,2	1.8	6,8	0,41	.32	.37	8	9
	50	345	3,45	28'	8,5	2.0	7,6	0,46	.34	.39	9	10
#2.0	30	207	2,07	29'	8,8	2.0	7,6	0,46	.39	.44	10	11
	40	276	2,76	30'	9,1	2.3	8,7	0,53	.42	.49	11	12
	50	345	3,45	31'	9,4	2.7	10,2	0,62	.42	.49	10	12
#3.0	30	207	2,07	32'	9,8	3.0	11,4	0,69	.48	.55	12	14
	40	276	2,76	33'	10,1	3.4	12,9	0,78	.45	.51	11	13
	50	345	3,45	33'	10,1	3.8	14,4	0,87	.52	.60	13	15

*All precipitation rates calculated for 180° operation. For the precipitation rate for a 360° sprinkler, divide by 2.

Specifications

- Inlet: 1/2" (1,3 cm) Threaded NPT
- Arc Adjustment Range: 40° – 360°
- Flow Range: .8 – 3.3 GPM (2,8 – 12,5 LPM)
- Pressure Rating: 20 – 70 PSI (1,4 – 4,8 bar)
- Precipitation Rate: .26 – .60 in/hr (6,6 – 15,24 mm/hr)
(depending on spacing and nozzle used)
- Overall Height (Popped Down): 6" (15,2 cm)
- Recommended Spacing: 17' – 34' (5,2 – 10,4 m)
- Radius: 18' – 33' (5,5 – 10,1 m)
- Nozzle Trajectory: 25°
- Riser Height: 4" (10,2 cm)

Models

RPS50 RPS™ 50 Rotor

OTHER OPTIONS: ADD TO PART NUMBER

-CV Check Valve





RPS™ 75

Application: Residential / Commercial



A wide selection of nozzles, including standard and low angle, provides flexibility in system design.

The K-Rain® patented reversing mechanism feature ensures continuous reverse and return. With a wide selection of standard and low angle nozzles, the RPS™ 75 provides matched precipitation. It is a direct replacement for Hunter® PGP® rotors.



Easy Arc Setting

Arc Selection 40° to 360°
Adjust From Right Start

Specifications

- Inlet: 3/4" (1,9 cm) Threaded NPT
- Arc Adjustment Range: 40° – 360°
- Flow Range: .75 – 8.2 GPM (2,6 – 32,6 LPM)
- Pressure Rating: 30 – 70 PSI (2,1 – 4,8 bars)
- Precipitation Rate: .16 – 1.01 in/hr (4 – 26 mm/hr)
(Depending on Spacing and Nozzle Used)
- Overall Height (Popped Down): 7 3/8" (19,7 cm)
- Recommended Spacing: 25' – 45' (7,6 – 13,7 m)
- Radius: 22' – 51' (6,7 – 15,5 m)
- Nozzle Trajectory: 26°
- Low Angle Nozzle Trajectory: 11°
- 8 Standard and 4 Low Angle Nozzles Included
- Riser Height: 4" (10,2 cm)

Models

RPS75	3/4" RPS™ 75 Rotor
RPS75-360°	3/4" RPS™ 75 Rotor, 360°
RPS75-SH	3/4" RPS™ 75 Rotor, Shrub
RPS75-360°-SH	3/4" RPS™ 75 Rotor, 360°, Shrub
RPS75-6INCH	6" RPS™ 75 Rotor

OTHER OPTIONS: ADD TO PART NUMBER

-SS	Stainless Steel
-CV	Check Valve
-NN	No Nozzle
-RCW	Reclaimed Water Use

Features and Benefits

- **Right Position Start** – Rotor rotates counterclockwise from fixed right start position.
- **Includes 5 Free Check Valve Assemblies Per Box**
- **Riser Fits in Existing Hunter® PGP® cans** – Simply unscrew the existing riser from the PGP® can and replace with the RPS™ 75 riser.
- **Top Adjustment** – Adjusts from right start.
- **Full and Part Circle Rotation** – Provides a full range of adjustment from 40° to 360°.
- **Non-flushing Wiper Seal** – Reduces leaks caused by debris trapped under seal.
- **3/4" (1,9 cm) Inlet** – Replaces all standard rotors.
- **Ideal for Low Flow Applications.**
- **Rubber Cover** – Seals out dirt and increases durability.
- **Wide Selection of Nozzles** – Including standard and low angle, provides flexibility in system design.

Performance Data

NOZZLE	PRESSURE			RADIUS		FLOW RATE			PRECIP in/hr		PRECIP mm/hr	
	PSI	kPa	Bars	Ft.	M.	GPM	L/M	M ³ /H	■	▲	■	▲
#0.75	30	206	2,1	29	8,8	0.7	2,6	0,16	0.16	0.19	4	5
	40	275	2,8	30	9,1	0.8	3,0	0,18	0.17	0.20	4	5
	50	344	3,4	30	9,1	0.9	3,4	0,20	0.19	0.22	5	6
	60	413	4,1	31	9,4	1.0	3,8	0,23	0.20	0.23	5	6
#1.0	30	206	2,1	30	9,1	0.9	3,4	0,20	0.19	0.22	5	6
	40	275	2,8	31	9,4	1.0	3,8	0,23	0.20	0.23	5	6
	50	344	3,4	31	9,4	1.2	4,5	0,27	0.24	0.28	6	7
	60	413	4,1	32	9,8	1.3	4,9	0,30	0.24	0.28	6	7
#1.5	30	206	2,1	32	9,8	1.2	4,5	0,27	0.23	0.26	5	6
	40	275	2,8	33	10,1	1.4	5,3	0,32	0.25	0.29	6	7
	50	344	3,4	34	10,4	1.6	6,1	0,36	0.27	0.31	7	8
	60	413	4,1	34	10,4	1.8	6,8	0,41	0.30	0.35	7	9
#2.0	30	206	2,1	34	10,4	1.6	6,1	0,36	0.27	0.31	7	8
	40	275	2,8	36	11,0	1.8	6,8	0,41	0.27	0.31	7	8
	50	344	3,4	38	11,6	2.0	7,6	0,45	0.27	0.31	7	8
	60	413	4,1	38	11,6	2.2	8,3	0,50	0.29	0.34	7	9
#3.0 Pre-installed	30	206	2,1	36	11,0	2.0	7,6	0,45	0.30	0.34	7	9
	40	275	2,8	38	11,6	2.4	9,1	0,55	0.32	0.37	8	9
	50	344	3,4	40	12,2	2.7	10,2	0,61	0.32	0.38	8	10
	60	413	4,1	40	12,2	2.9	11,0	0,66	0.35	0.40	9	10
#4.0	30	206	2,1	36	11,0	2.6	9,8	0,59	0.39	0.45	10	11
	40	275	2,8	40	12,2	3.0	11,4	0,68	0.36	0.42	9	11
	50	344	3,4	42	12,8	3.4	12,9	0,77	0.37	0.43	9	11
	60	413	4,1	42	12,8	3.7	14,0	0,84	0.40	0.47	9	12
#6.0	40	275	2,8	38	11,6	4.2	15,9	0,91	0.56	0.65	14	16
	50	344	3,4	43	13,1	4.9	18,5	1,11	0.51	0.59	13	15
	60	413	4,1	46	14,0	5.5	20,8	1,25	0.50	0.58	13	15
	70	482	4,8	47	14,3	6.0	22,7	1,36	0.52	0.60	13	15
#8.0	40	275	2,8	45	13,7	6.0	22,7	1,36	0.57	0.66	14	17
	50	344	3,4	48	14,6	6.8	25,7	1,54	0.57	0.66	14	17
	60	413	4,1	49	14,9	7.6	28,8	1,73	0.61	0.70	15	18
	70	482	4,8	51	15,5	8.2	31,0	1,86	0.61	0.70	15	18

Low Angle Performance Data

NOZZLE	PRESSURE			RADIUS		FLOW RATE			PRECIP in/hr		PRECIP mm/hr	
	PSI	kPa	Bars	Ft.	M.	GPM	L/M	M ³ /H	■	▲	■	▲
#1.0	30	207	2,1	22	6,7	1.2	4,5	0,34	0.48	0.55	12	14
	40	275	2,8	24	7,3	1.7	6,4	0,39	0.57	0.66	14	17
	50	344	3,4	26	7,9	1.8	6,8	0,41	0.51	0.59	13	15
	60	413	4,1	28	8,5	2.0	7,6	0,46	0.49	0.57	13	14
#3.0	30	207	2,1	29	8,8	3.0	11,4	0,68	0.69	0.79	18	20
	40	275	2,8	32	9,8	3.1	11,7	0,71	0.58	0.67	15	17
	50	344	3,4	35	10,7	3.5	13,2	0,80	0.55	0.64	14	16
	60	413	4,1	37	11,3	3.8	14,4	0,87	0.53	0.62	13	16
#4.0	30	207	2,1	31	9,4	3.4	12,9	0,78	0.68	0.79	17	20
	40	275	2,8	34	10,4	3.9	14,8	0,89	0.65	0.75	16	19
	50	344	3,4	37	11,3	4.4	16,7	1,00	0.62	0.71	16	18
	60	413	4,1	38	11,6	4.7	17,8	1,07	0.63	0.72	16	18
#6.0	40	275	2,8	38	11,6	6.5	24,6	1,68	0.87	1.00	22	25
	50	344	3,5	40	12,2	7.3	27,6	1,66	0.88	1.01	22	25
	60	413	4,1	42	12,8	8.0	30,3	1,82	0.87	1.01	22	26
	70	482	4,8	44	13,4	8.3	32,6	1,96	0.86	0.99	22	25

*All precipitation rates calculated for 180° operation. For the precipitation rate for a 360° sprinkler, divide by 2.





RPS™ 75i

Application: Residential / Commercial



Patented Intelligent Flow Technology® allows distance and water flow to be reduced simultaneously and proportionately up to 50%.

With a simple turn of the Flow Control, RPS™ 75i delivers even water distribution, eliminates dry spots and provides better zone performance. Experience superior uniformity and water savings up to 30%.

A direct replacement for Hunter® PGP® and PGP Ultra®, the RPS™ 75i fits right into the same can.

Easy Arc Setting

Arc Selection 40° to 360°

Adjust From Right Start



Intelligent Flow Technology®

Features and Benefits

- Reduce Distance and Flow Rate Proportionately.
- Includes 5 Free Check Valve Assemblies Per Box
- Save Time on Every Project — New or retrofit.
- Rugged RPS Family Construction.
- Conserves Water.
- Superior Uniformity.
- Fewer Zones Required.
- Improved Hydraulics.

Models

RPS 75i	3/4" RPS™ 75i Rotor
RPS75i-360°	3/4" RPS™ 75i Rotor, 360°
RPS75i-SH	3/4" RPS™ 75i Rotor, Shrub
RPS75i-360°-SH	3/4" RPS™ 75i Rotor, Shrub, 360°
RPS75i-6INCH	6" RPS™ 75i Rotor

OTHER OPTIONS: ADD TO PART NUMBER

-SS	Stainless Steel
-CV	Check Valve
-NN	No Nozzle
-RCW	Reclaimed Water Use

Specifications

- Inlet: 3/4" (1,9 cm) Threaded NPT
- Arc Adjustment Range: 40° – 360°
- Flow Range: .4 – 9.7 GPM (1,5 – 36,7 LPM)
- Pressure Rating: 30 – 70 PSI (2,1 – 4,8 bar)
- Precipitation Rate: .22 – 1.95 in/hr (6 – 50 mm/hr)
- Overall Height (Popped Down): 7 3/8" (19,7 cm)
- Recommended Spacing: 17' – 45' (5,2 – 13,7 m)
- Radius: 13' – 48' (4 – 14,6 m)
- Nozzle Trajectory: 26°
- Low Angle Nozzle Trajectory: 11°
- Nozzles Included: 8 Standard, 4 Low Angle
- Riser Height: 4" (10,2 cm)

Performance Data

NOZZLE	PRESSURE PSI kPa Bar		NO ADJUSTMENT								-30% ADJUSTMENT								-50% ADJUSTMENT								
			RADIUS		FLOW		PRECIP in/hr mm/hr				RADIUS		FLOW		PRECIP in/hr mm/hr				RADIUS		FLOW		PRECIP in/hr mm/hr				
			Ft.	M.	GPM	L/M	■	▲	■	▲	Ft.	M.	GPM	L/M	■	▲	■	▲	Ft.	M.	GPM	L/M	■	▲	■	▲	
#1.0	30	207	2,1	31'	9,4	1.1	4,2	.22	.25	6	6	22'	7	0.8	3,0	.31	.36	8	9	16	5	0.6	2,3	.44	.51	11	13
	40	276	2,8	32'	9,8	1.4	5,3	.26	.30	7	8	22'	7	1.0	3,8	.38	.43	10	11	16	5	0.7	2,7	.53	.61	13	15
	50	345	3,4	33'	10,1	1.6	6,1	.28	.33	7	8	23'	7	1.1	4,1	.40	.47	10	12	17	5	0.8	3,0	.57	.65	14	17
	60	414	4,1	34'	10,4	1.8	6,8	.30	.35	8	9	24'	7	1.3	4,9	.43	.49	11	13	17	5	0.9	3,4	.60	.69	15	18
#1.5	30	207	2,1	33'	10,1	1.5	5,7	.27	.31	7	8	23'	7	1.1	4,1	.38	.44	10	11	17	5	0.8	3,0	.53	.61	13	16
	40	276	2,8	35'	10,7	1.8	6,8	.28	.33	7	8	25'	8	1.3	4,9	.40	.47	10	12	18	5	0.9	3,4	.57	.65	14	17
	50	345	3,4	35'	10,7	2.0	7,6	.31	.36	8	9	25'	8	1.4	5,3	.45	.52	11	13	18	5	1.0	3,8	.63	.73	16	18
	60	414	4,1	36'	11,0	2.2	8,3	.33	.38	8	10	25'	8	1.5	5,7	.47	.54	12	14	18	5	1.1	4,2	.65	.76	17	19
#2.0	30	207	2,1	33'	10,1	1.8	6,8	.32	.37	8	9	23'	7	1.3	4,9	.45	.53	11	13	17	5	0.9	3,4	.64	.74	16	19
	40	276	2,8	34'	10,4	2.1	7,9	.35	.40	9	10	24'	7	1.5	5,7	.50	.58	13	15	17	5	1.1	4,2	.70	.81	18	21
	50	345	3,4	36'	11,0	2.4	9,1	.36	.41	9	10	25'	8	1.7	6,4	.51	.59	13	15	18	5	1.2	4,5	.71	.82	18	21
	60	414	4,1	38'	11,6	2.7	10,2	.36	.42	9	11	27'	8	1.9	7,2	.51	.59	13	15	19	6	1.4	5,3	.72	.83	18	21
#2.5 Pre- installed	30	207	2,1	35'	10,7	2.2	8,3	.35	.40	9	10	25'	8	1.5	5,7	.49	.57	12	14	18	5	1.1	4,2	.69	.80	18	20
	40	276	2,8	38'	11,6	2.6	9,8	.35	.40	9	10	27'	8	1.8	6,8	.50	.57	13	15	19	6	1.3	4,9	.69	.80	18	20
	50	345	3,4	39'	11,9	3.0	11,4	.38	.44	10	11	27'	8	2.1	7,9	.54	.63	14	16	20	6	1.5	5,7	.76	.88	19	22
	60	414	4,1	40'	12,2	3.3	12,5	.40	.46	10	12	28'	9	2.3	8,7	.57	.66	14	17	20	6	1.7	6,4	.79	.92	20	23
#3.0	30	207	2,1	38'	11,6	2.7	10,2	.36	.42	9	11	27'	8	1.9	7,1	.51	.59	13	15	19	6	1.4	5,3	.72	.83	18	21
	40	276	2,8	40'	12,2	3.1	11,7	.37	.43	9	11	28'	9	2.2	8,3	.53	.62	13	16	20	6	1.6	6,1	.75	.86	19	22
	50	345	3,4	41'	12,5	3.5	13,3	.40	.46	10	12	29'	9	2.5	9,5	.57	.66	14	17	21	6	1.8	6,8	.80	.93	20	24
	60	414	4,1	41'	12,5	3.9	14,8	.45	.52	11	13	29'	9	2.7	10,2	.64	.74	16	19	21	6	2.0	7,6	.89	1.03	23	26
#4.0	30	207	2,1	38'	11,6	3.5	13,3	.47	.54	12	14	27'	8	2.5	9,5	.67	.77	17	20	19	6	1.8	6,8	.93	1.08	24	27
	40	276	2,8	40'	12,2	4.0	15,1	.48	.56	12	14	28'	9	2.8	10,6	.69	.79	18	20	20	6	2.0	7,6	.96	1.11	24	28
	50	345	3,4	43'	13,1	4.4	16,7	.46	.53	12	13	30'	9	3.1	11,7	.65	.76	17	19	22	7	2.2	8,3	.92	1.06	23	27
	60	414	4,1	43'	13,1	4.9	18,6	.51	.59	13	15	30'	9	3.4	12,9	.73	.84	19	21	22	7	2.5	9,5	1.02	1.18	26	30
#5.0	30	207	2,1	43'	13,1	4.4	16,7	.46	.53	12	13	30'	9	3.1	11,7	.65	.76	17	19	22	7	2.2	8,3	.92	1.06	23	27
	40	276	2,8	43'	13,1	5.0	18,9	.52	.60	13	15	30'	9	3.5	13,3	.74	.86	19	22	22	7	2.5	9,5	1.04	1.20	26	31
	50	345	3,4	44'	13,4	5.5	20,8	.55	.63	14	16	31'	9	3.9	14,8	.78	.90	20	23	22	7	2.8	10,6	1.09	1.26	28	32
	60	414	4,1	42'	12,8	5.9	22,3	.64	.74	16	19	29'	9	4.1	15,5	.92	1.06	23	27	21	6	3.0	11,4	1.29	1.49	28	38
#6.0	30	207	2,1	40'	12,2	5.0	18,9	.60	.70	15	18	28'	9	3.5	13,3	.86	.99	22	25	20	6	2.5	9,5	1.20	1.39	30	35
	40	276	2,8	43'	13,1	5.9	22,3	.61	.71	15	18	30'	9	4.1	15,5	.88	1.01	22	26	22	7	3.0	11,4	1.23	1.42	31	36
	50	345	3,4	43'	13,1	6.6	25,0	.69	.79	18	20	30'	9	4.6	17,4	.98	1.13	25	29	22	7	3.3	12,5	1.37	1.59	35	40
	60	414	4,1	44'	13,4	7.3	27,6	.73	.84	19	21	31'	9	5.1	19,3	1.04	1.20	26	30	22	7	3.7	14,0	1.45	1.68	37	43
#8.0	30	276	2,8	43'	13,1	6.8	25,7	.71	.82	18	21	30'	9	4.8	18,2	1.01	1.17	26	30	22	7	3.4	12,9	1.42	1.64	36	42
	40	345	3,4	47'	14,3	7.9	29,9	.69	.80	18	20	33'	10	5.5	20,8	.98	1.14	25	29	24	7	4.0	15,1	1.38	1.59	35	40
	50	414	4,1	48'	14,6	8.8	33,3	.74	.85	19	22	34'	10	6.2	23,5	1.05	1.21	27	31	24	7	4.4	16,7	1.47	1.70	37	43
	60	483	4,8	47'	14,3	9.7	36,7	.85	.98	22	25	33'	10	6.8	25,7	1.21	1.40	31	35	24	7	4.9	18,6	1.69	1.95	43	50

Low Angle Performance Data

NOZZLE	PRESSURE PSI kPa Bar		NO ADJUSTMENT								-30% ADJUSTMENT								-50% ADJUSTMENT								
			RADIUS		FLOW		PRECIP in/hr mm/hr				RADIUS		FLOW		PRECIP in/hr mm/hr				RADIUS		FLOW		PRECIP in/hr mm/hr				
			Ft.	M.	GPM	L/M	■	▲	■	▲	Ft.	M.	GPM	L/M	■	▲	■	▲	Ft.	M.	GPM	L/M	■	▲	■	▲	
#1.0	30	207	2,1	26'	7,9	0.9	3,4	.25	.29	6	7	18'	5	0.6	2,3	.35	.41	9	10	13	4	0.4	1,5	.50	.57	13	15
	40	276	2,8	27'	8,2	1.0	3,8	.26	.31	7	8	19'	6	0.7	2,7	.38	.44	10	11	14	4	0.5	1,9	.53	.61	13	15
	50	345	3,4	27'	8,2	1.2	4,5	.32	.37	8	9	19'	6	0.8	3,0	.45	.52	11	13	14	4	0.6	2,3	.63	.73	16	19
	60	414	4,1	26'	7,9	1.4	5,3	.40	.46	10	12	18'	5	1.0	3,8	.57	.66	14	17	13	4	0.7	2,7	.80	.92	20	24
#1.5	30	207	2,1	28'	8,5	1.3	4,9	.32	.37	8	9	20'	6	0.9	3,4	.46	.53	12	13	14	4	0.7	2,7	.64	.74	16	19
	40	276	2,8	29'	8,8	1.5	5,7	.34	.40	9	10	20'	6	1.1	4,2	.49	.57	12	14	15	5	0.8	3,0	.69	.79	18	20
	50	345	3,4	30'	9,1	1.7	6,4	.36	.42	9	11	21'	6	1.2	4,5	.52	.60	13	15	15	5	0.9	3,4	.73	.84	19	21
	60	414	4,1	31'	9,4	1.9	7,2	.38	.44	10	11	22'	7	1.3	4,9	.54	.63	14	16	16	5	1.0	3,8	.76	.88	19	22
#2.0	30	207	2,1	29'	8,8	1.9	7,2	.44	.50	11	13	20'	6	1.3	4,9	.62	.72	16	18	15	5	1.0	3,8	.87	1.00	22	26
	40	276	2,8	32'	9,8	2.2	8,3	.41	.48	10	12	22'	7	1.5	5,7	.59	.68	15	17	16	5	1.1	4,2	.83	.96	21	24
	50	345	3,4	33'	10,1	2.5	9,5	.44	.51	11	13	23'	7	1.8	6,8	.63	.73	16	19	17	5	1.3	4,9	.88	1.02	22	26
	60	414	4,1	34'	10,4	2.8	10,6	.47	.54	12	14	24'	7	2.0	7,6	.67	.77	17	20	17	5	1.4	5,3	.93	1.08	24	27
#3.0	30	207	2,1	32'	9,8	2.5	9,5	.47	.54	13	14	22'	7														

RPS™ SELECT

Application: Residential / Commercial

RPS™ Select offers four pre-installed nozzles with greater water efficiency, allowing you to enjoy installation convenience and matched precipitation without hassles.

The K-Rain® RPS™ Select rotary sprinkler is the first gear-driven sprinkler that makes matched precipitation fast and easy, without the need to change nozzles in the field. It offers a choice of 4 selectable built-in nozzles.

With a twist of a flathead screwdriver, quickly select the correct nozzle to match the arc setting of the sprinkler or landscape.

No nozzle trees to carry or lose. Using a combination of four nozzles, it's easy to achieve matched precipitation across all arc settings.

The four built-in nozzles also make RPS™ Select a convenient universal replacement sprinkler for other brands.

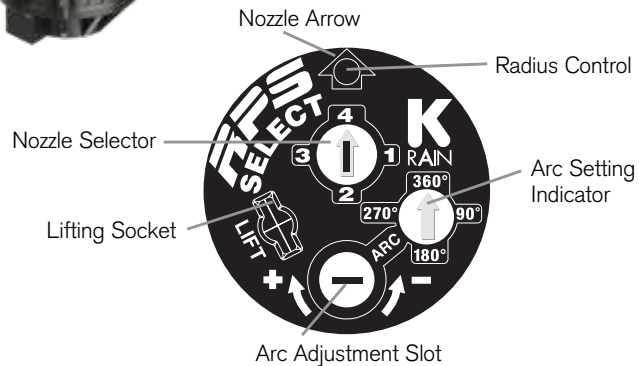

Features and Benefits

- **Four Built-in Selectable Nozzles** – Nozzles #1 through #4 match arc settings 90° through 360°.
- **Adjustable Arc (from 40°-360°); All Adjustments Made From The Top** – Adjust wet or dry, no special tools needed.
- **Matched Precipitation Rates** – When nozzle setting matched to arc.
- **Precision-Engineered Nozzles** – Ensures water-saving efficiency.
- **Standard Rubber Cover.**
- **Proven Water-lubricated Gear-drive Design** – Common to the popular RPS® 75 Series.
- **Universal Riser Assembly** – Interchangeable with most popular irrigation rotors.
- **Low-pressure Operation.**

Performance Data

NOZZLE	PRESSURE			RADIUS		FLOW RATE			PRECIP in/hr		PRECIP mm/hr	
	PSI	kPa	Bars	Ft.	M.	GPM	L/M	M ³ /H	■	▲	■	▲
#1.0	30	207	2,1	33'	10,1	1.3	4,9	0,29	.23	.24	6	7
	35	241	2,4	34'	10,4	1.4	5,3	0,32	.23	.27	6	7
	40	276	2,8	37'	10,4	1.5	5,7	0,34	.21	.29	6	7
	45	310	3,1	37'	11,3	1.6	6,1	0,37	.22	.26	6	7
	50	345	3,4	37'	11,3	1.8	6,8	0,41	.25	.29	6	7
#2.0	30	207	2,1	37'	11,3	2.6	9,8	0,59	.37	.42	9	11
	35	241	2,4	38'	11,6	2.8	10,6	0,64	.37	.43	9	11
	40	276	2,8	39'	11,9	3.0	11,4	0,68	.38	.44	10	11
	45	310	3,1	40'	12,2	3.2	12,1	0,73	.39	.44	10	11
	50	345	3,4	40'	12,2	3.6	13,6	0,82	.43	.50	11	13
#3.0	30	207	2,1	37'	11,3	3.8	14,4	0,86	.53	.62	14	16
	35	241	2,4	40'	12,2	4.1	15,5	0,93	.49	.57	13	14
	40	276	2,8	41'	12,2	4.5	17,0	1,02	.52	.60	13	15
	45	310	3,1	41'	12,5	4.7	17,8	1,07	.54	.62	14	16
	50	345	3,4	43'	13,1	4.9	18,5	1,11	.51	.59	13	15
#4.0	30	207	2,1	38'	11,6	5.2	19,6	1,18	.69	.80	18	20
	35	241	2,4	40'	12,2	5.7	21,5	1,29	.69	.79	17	20
	40	276	2,8	44'	13,4	6.0	22,7	1,36	.60	.69	15	17
	45	310	3,1	45'	13,7	6.4	24,2	1,45	.61	.70	15	18
	50	345	3,4	46'	14,0	6.8	25,7	1,54	.62	.71	16	18

*All precipitation rates calculated for 180° operation. For the precipitation rate for a 360° sprinkler, divide by 2.

Specifications

- Inlet: 3/4" (1,9 cm) Threaded NPT
- Arc Adjustment Range: 40° – 360°
- Flow Range: 1.3 – 6.8 GPM (4,9 – 25,8 LPM)
- Pressure Rating: 30 – 70 PSI (2,1 – 4,8 bar)
- Precipitation Rate: .23 – .71 in/hr (6 – 20 mm/hr)
(Depending on Spacing and Nozzle Used)
- Overall Height (Popped Down): 7-3/8" (19,7 cm)
- Recommended Spacing: 31' - 44' (9,1 – 13,4 m)
- Radius: 33' – 46' (10 – 14 m)

Models

- 60003 RPS™ Select Rotor
- 60003-SH RPS™ Select Rotor, Shrub
- 60003-6INCH 6" RPS™ Select Rotor

OTHER OPTIONS: ADD TO PART NUMBER

- CV Check Valve
- RCW Reclaimed Water Use



SUPERPRO®

Application: Residential / Commercial



SuperPro® with Intelligent Flow Technology® allows distance and water flow to be reduced simultaneously and proportionately.

Patented Intelligent Flow Technology® allows the reduction of distance while reducing the flow rate 50%! Water savings of up to 30% is achievable with this patented feature.

SuperPro® delivers matched precipitation, eliminates dry spots and provides better zone performance. Water flow can be turned off during nozzle installation or adjustment, with the riser remaining in popped-up position.

Specifications

- Inlet: 3/4" (1,9 cm) Threaded NPT
- Arc Adjustment Range: 40° to Continuous 360°
- Flow Range: .5 – 9.5 GPM (1,9 – 36 LPM)
- Pressure Rating: 20 – 70 PSI (1,4 – 4,8 bar)
- Precipitation Rate: .21 – 1.17 in/hr (5,39 a 30,89 mm/hr) (Depending on Spacing and Nozzle Used)
- Overall Height (Popped Down): 7 1/2" (19 cm)
- Recommended Spacing: 28' – 44' (8,5 a 13,4 m)
- Radius: 26' – 46' (7,9 a 14,0 m)
- Nozzle Trajectory: 26°
- Low Angle Nozzle Trajectory: 12°
- Standard and Low Angle Nozzles Included
- Riser Height: 4" (10,2 cm)

Features and Benefits

- **Revolutionary Patented Easy Arc Set** – Simplified arc set allows for wet or dry adjustment in seconds.
- **2 in 1 Adjustable or Continuous Rotation** – Provides a full range of adjustment from 40° to continuous 360°.
- **Patented Arc Set Degree Markings** – Clearly indicates current watering pattern, simplifies arc set adjustment.
- **Arc Memory Clutch** – Prevents internal gear damage and returns rotor to its prior setting automatically if nozzle turret is forced out of adjustment.
- **Time Proven Patented Reversing Mechanism** – Assures continuous reverse and return...over a 35 year history.
- **Ratcheting Riser** – Allows for easy adjustment of your left starting position with a simple turn of the riser.
- **Rubber Cover** – Seals out dirt and increases product durability.
- **Optional Check Valve** – Prevents low head drainage.
- **Rugged Stainless Steel Spring** – .093 gauge 302 stainless steel spring extends the life of the rotor.

Models

10003 SuperPro®

OTHER OPTIONS: ADD TO PART NUMBER

-HP	12" (30,5 cm) High Pop
-SH	Shrub Head
-CV	Check Valve
-NN	No Nozzle
-RCW	Reclaimed Water Use
-OS	On-site wastewater applications with #3 low angle nozzle pre-installed

Easy Arc Setting

Arc Selection 40° to Continuous 360°

Adjust From Left Start



Intelligent Flow
Technology®

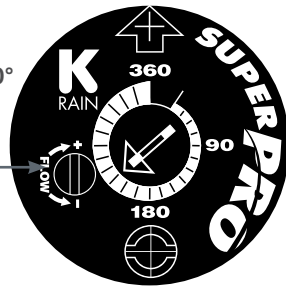

- Reduces distance and flow rate proportionately
- Provides full on/off control

Performance Data

NOZZLE	PRESSURE			RADIUS		FLOW RATE			PRECIP in/hr		PRECIP mm/hr	
	PSI	kPa	Bars	Ft.	M.	GPM	L/M	M ³ /H	■	▲	■	▲
#1	30	207	2,1	30	10,1	1.2	4,5	0,3	0.21	0.25	5	6
	40	276	2,8	31	10,1	1.3	4,9	0,3	0.23	0.27	6	7
	50	345	3,4	31	10,1	1.5	5,7	0,3	0.27	0.31	7	8
	60	414	4,1	32	10,1	1.8	6,8	0,4	0.32	0.37	8	9
#1.5	30	207	2,1	36	11,0	1.5	5,7	0,3	0.22	0.26	6	6
	40	276	2,8	37	11,3	1.8	6,8	0,4	0.25	0.29	6	7
	50	345	3,4	37	11,3	2.0	7,6	0,5	0.28	0.32	7	8
	60	414	4,1	38	11,6	2.2	8,3	0,5	0.29	0.34	7	9
#2	30	207	2,1	35	10,7	1.8	6,8	0,4	0.28	0.33	7	8
	40	276	2,8	35	10,7	2.2	8,3	0,5	0.35	0.40	9	10
	50	345	3,4	36	11,0	2.6	9,8	0,6	0.39	0.45	10	11
	60	414	4,1	38	11,6	2.9	11,0	0,7	0.39	0.45	10	11
#2.5 Pre-installed	30	207	2,1	37	11,3	2.5	9,5	0,6	0.35	0.41	9	10
	40	276	2,8	38	11,6	3.0	11,4	0,7	0.40	0.46	10	12
	50	345	3,4	40	12,2	3.4	12,9	0,8	0.41	0.47	10	12
	60	414	4,1	40	12,2	3.8	14,4	0,9	0.46	0.53	12	13
#3	30	207	2,1	36	11,0	3.0	11,4	0,7	0.45	0.51	11	13
	40	276	2,8	37	11,3	3.4	12,9	0,8	0.48	0.55	12	14
	50	345	3,4	38	11,6	4.0	15,1	0,9	0.53	0.62	13	16
	60	414	4,1	41	12,5	4.4	16,7	1,0	0.50	0.58	13	15
#4	30	207	2,1	37	11,3	4.0	15,1	0,9	0.56	0.65	14	16
	40	276	2,8	39	11,9	4.5	17,0	1,0	0.57	0.66	14	17
	50	345	3,4	39	11,9	5.2	19,7	1,2	0.66	0.76	17	19
	60	414	4,1	40	12,2	5.6	21,2	1,3	0.67	0.78	17	20
#5	30	207	2,1	37	11,3	4.8	18,2	1,1	0.68	0.78	17	20
	40	276	2,8	38	11,6	5.6	21,2	1,3	0.75	0.86	19	22
	50	345	3,4	41	12,5	6.5	24,6	1,5	0.74	0.86	19	22
	60	414	4,1	43	13,1	7.2	27,3	1,6	0.75	0.87	19	22
#6	30	207	2,1	40	12,2	6.0	22,7	1,4	0.72	0.83	18	21
	40	276	2,8	41	12,5	6.8	25,7	1,5	0.78	0.90	20	23
	50	345	3,4	42	12,8	7.5	28,4	1,7	0.82	0.95	21	24
	60	414	4,1	44	13,4	8.4	31,8	1,9	0.84	0.96	21	24
#8	30	207	2,1	38	11,6	7.9	29,9	1,8	1.05	1.22	27	31
	40	276	2,8	44	13,4	9.2	34,8	2,1	0.92	1.06	23	27
	50	345	3,4	45	13,7	10.4	39,4	2,4	0.99	1.14	25	29
	60	414	4,1	46	14,0	11.1	42,0	2,5	1.01	1.17	26	30

Low Angle Performance Data

NOZZLE	PRESSURE			RADIUS		FLOW RATE			PRECIP in/hr		PRECIP mm/hr	
	PSI	kPa	Bars	Ft.	M.	GPM	L/M	M ³ /H	■	▲	■	▲
#1.0	30	207	2,1	26	7,9	1.1	4,2	0,2	0.31	0.36	8	9
	40	276	2,8	30	9,1	1.3	4,9	0,3	0.28	0.32	7	8
	50	345	3,4	30	9,1	1.4	5,3	0,3	0.30	0.35	8	9
	60	414	4,1	30	9,1	1.6	6,1	0,4	0.34	0.40	9	10
#1.5	30	207	2,1	27	8,2	1.4	5,3	0,3	0.37	0.43	9	11
	40	276	2,8	28	8,5	1.7	6,4	0,4	0.42	0.48	11	12
	50	345	3,4	31	9,4	1.9	7,2	0,4	0.38	0.44	10	11
	60	414	4,1	30	9,1	2.1	7,9	0,5	0.45	0.52	11	13
#2	30	207	2,1	30	9,1	2.1	7,9	0,5	0.45	0.52	11	13
	40	276	2,8	31	9,4	2.4	9,1	0,5	0.48	0.56	12	14
	50	345	3,4	33	10,1	2.8	10,6	0,6	0.50	0.57	12	14
	60	414	4,1	31	9,4	3.1	11,7	0,7	0.62	0.72	16	18
#3	30	207	2,1	32	9,8	3.0	11,4	0,7	0.56	0.65	14	16
	40	276	2,8	34	10,4	3.5	13,2	0,8	0.58	0.67	15	17
	50	345	3,4	35	10,7	3.9	14,8	0,9	0.61	0.71	15	18
	60	414	4,1	35	10,7	4.3	16,3	1,0	0.68	0.78	17	20

*All precipitation rates calculated for 180° operation. For the precipitation rate for a 360° sprinkler, divide by 2.



PROPLUS®

Application: Residential / Commercial



The ProPlus® is packed with features which ensures reliability; saving the installer time and money on every job.

The ProPlus® adjustable arc and continuous full-circle gear driven rotor comes standard with nine numerically coded interchangeable nozzles. Excellent nozzle performance delivers an exceptional fall out pattern. In independent testing by C.I.T., the ProPlus® delivered up to 90% uniform coverage.

Tough, proven and advanced, the ProPlus® is the leader in it's class. Set it and forget it. Arc Memory Clutch returns the rotor to its preset position. Technology works for you.

Easy Arc Setting

Arc Selection 40°
to Continuous 360°
Adjust From Left Start

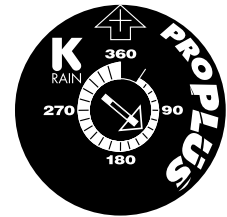

Specifications

- Inlet: (1,9 cm) 3/4" Threaded NPT
- Arc Adjustment Range: 40° to Continuous 360°
- Flow Range: .5 – 10.0 GPM (1,9 – 37,8 LPM)
- Pressure Rating: 20 – 70 PSI (2 – 4,8 bars)
- Precipitation Rate: .12 – .89 in/hr (3 – 26 mm/hr)
(Depending on Spacing and Nozzle Used)
- Overall Height (Popped Down): 7 1/2" (19 cm)
(17" (43,2 cm) for High Pop Model)
- Recommended Spacing: 28' – 44' (8,5 – 13,2 m)
- Radius: 22' – 50' (6,7 – 15,3 m)
- Nozzle Trajectory: 26°
- Low Angle Nozzle Trajectory: 12°
- Standard and Low Angle Nozzles Included
- Riser Height: 5" (12,7 cm) and 12" (30,5 cm)

Models

- 11003 ProPlus®
- 11003-HP ProPlus® (30,5 cm) 12" High Pop
- 11003-SH ProPlus® Shrub Head

OTHER OPTIONS: ADD TO PART NUMBER

- CV Check Valve
- LA Low Angle Nozzle
- NN No Nozzle
- RCW Reclaimed Water Use

Features and Benefits

- **Revolutionary Patented Top Arc Set** – Simplified arc set allows for wet or dry adjustment in seconds.
- **5" (12,7 cm) Riser** – Perfect for grasses with thick thatch.
- **3/4" (1,9 cm) Inlet** – Replaces all standard rotors.
- **2N1 Adjustable or Continuous Rotation** – Provides a full range adjustment from 40° to a continuous full circle.
- **Patented Arc Set Degree Markings** – Clearly indicates current watering pattern & simplifies arc set adjustment.
- **Arc Memory Clutch** – Prevents internal gear damage and returns rotor to its prior setting automatically if nozzle turret is forced past its stop.
- **Time Proven Patented Reversing Mechanism** – Assures continuous reverse and return...over a 35 year history.
- **Ratcheting Riser** – Allows for easy adjustment of your fixed starting position with a simple turn of the riser.
- **Rubber Cover** – Seals out dirt, increases product durability.
- **Wide Selection of Nozzles** – Including standard and low angle, provides flexibility in system design.
- **Optional Check Valve** – Prevents low head drainage.

Performance Data

NOZZLE	PRESSURE			RADIUS		FLOW RATE			PRECIP in/hr		PRECIP mm/hr	
	PSI	kPa	Bars	Ft.	M.	GPM	L/M	M ³ /H	■	▲	■	▲
#0.5	30	207	2,1	28	8,5	0.5	1,9	0,11	0.12	0.14	3	4
	40	276	2,8	29	8,8	0.6	2,3	0,14	0.14	0.16	3	4
	50	345	3,5	29	8,8	0.7	2,7	0,16	0.16	0.19	4	5
	60	414	4,1	30	9,1	0.8	3,0	0,18	0.17	0.20	4	5
#0.75	30	207	2,1	29	8,8	0.7	2,7	0,16	0.16	0.19	4	5
	40	275	2,8	30	9,1	0.8	3,0	0,18	0.17	0.20	4	5
	50	344	3,4	31	9,4	0.9	3,4	0,20	0.18	0.21	5	5
	60	413	4,1	32	9,8	1.0	3,8	0,23	0.19	0.22	5	6
#1.0	30	207	2,1	32	9,8	1.3	4,9	0,30	0.24	0.28	6	7
	40	275	2,8	33	10,1	1.5	5,7	0,34	0.27	0.31	7	8
	50	344	3,4	34	10,4	1.6	6,1	0,36	0.27	0.31	7	8
	60	413	4,1	35	10,7	1.8	6,8	0,41	0.28	0.33	7	8
#2.0	30	207	2,1	37	11,3	2.4	9,1	0,55	0.34	0.39	9	10
	40	275	2,8	40	12,2	2.5	9,5	0,57	0.30	0.35	8	9
	50	344	3,4	42	12,8	3.0	11,4	0,68	0.33	0.38	8	10
	60	413	4,1	43	13,1	3.3	11,4	0,68	0.34	0.36	8	9
2.5 Pre-installed	30	207	2,1	38	11,6	2.5	9,5	0,57	0.33	0.38	8	10
	40	275	2,8	39	11,9	2.8	10,6	0,64	0.35	0.41	9	10
	50	344	3,4	40	12,2	3.2	12,1	0,73	0.39	0.44	10	11
	60	413	4,1	41	12,5	3.5	13,3	0,80	0.40	0.46	10	12
#3.0	30	207	2,1	38	11,6	3.6	13,6	0,82	0.48	0.55	12	14
	40	275	2,8	39	11,9	4.2	15,9	0,96	0.53	0.61	14	16
	50	344	3,4	41	12,5	4.6	17,4	1,05	0.53	0.61	13	15
	60	413	4,1	42	12,8	5.0	19,0	1,14	0.55	0.63	14	16
#4.0	30	207	2,1	43	13,1	4.4	16,7	1,00	0.46	0.53	12	13
	40	275	2,8	44	13,4	5.1	19,3	1,16	0.51	0.59	13	15
	50	344	3,4	46	14,0	5.6	21,2	1,27	0.51	0.59	13	15
	60	413	4,1	49	14,9	5.9	22,4	1,34	0.47	0.55	12	14
#6.0	40	276	2,8	45	13,7	5.9	22,4	1,34	0.56	0.65	14	16
	50	344	3,4	46	14,0	6.0	22,7	1,36	0.55	0.63	14	16
	60	413	4,1	48	14,6	6.3	23,9	1,43	0.53	0.61	13	15
	70	482	4,8	49	14,9	6.7	25,4	1,52	0.54	0.62	14	16
#8.0	40	276	2,8	42	12,8	8.0	30,3	1,82	0.87	1.01	22	26
	50	344	3,4	45	13,7	8.5	32,2	1,93	0.81	0.93	21	24
	60	413	4,1	49	14,9	9.5	36,0	2,16	0.76	0.88	19	22
	70	482	4,8	50	15,2	10.0	37,9	2,27	0.77	0.89	20	23

Low Angle Performance Data

NOZZLE	PRESSURE			RADIUS		FLOW RATE			PRECIP in/hr		PRECIP mm/hr	
	PSI	kPa	Bars	Ft.	M.	GPM	L/M	M ³ /H	■	▲	■	▲
#1.0	30	207	2,1	22	6,7	1.2	4,5	0,27	0.48	0.55	12	14
	40	276	2,8	24	7,3	1.7	6,4	0,39	0.57	0.66	14	17
	50	345	3,4	26	7,9	1.8	6,8	0,41	0.51	0.59	13	15
	60	414	4,1	28	8,5	2.0	7,6	0,45	0.49	0.57	12	14
#3.0	30	207	2,1	29	8,8	3.0	11,4	0,68	0.69	0.79	17	20
	40	276	2,8	32	9,8	3.1	11,7	0,70	0.58	0.67	15	17
	50	345	3,4	35	10,7	3.5	13,2	0,80	0.55	0.64	14	16
	60	414	4,1	37	11,3	3.8	14,4	0,86	0.53	0.62	14	16
#4.0	30	207	2,1	31	9,4	3.4	12,9	0,77	0.68	0.79	17	20
	40	276	2,8	34	10,4	3.9	14,8	0,89	0.65	0.75	17	19
	50	345	3,4	37	11,3	4.4	16,7	1,00	0.62	0.71	16	18
	60	414	4,1	38	11,6	4.7	17,8	1,07	0.63	0.72	16	18
#6.0	40	275	2,8	38	11,6	6.5	24,6	1,48	0.87	1.00	22	25
	50	344	3,4	40	12,2	7.3	27,7	1,66	0.88	1.01	22	26
	60	413	4,1	42	12,8	8.0	30,3	1,82	0.87	1.01	22	26
	70	482	4,8	44	13,4	8.6	32,6	1,96	0.86	0.99	22	25

*All precipitation rates calculated for 180° operation. For the precipitation rate for a 360° sprinkler, divide by 2.





PROSPORT®

Application: Commercial / Sports Turf



Designed specifically for sports turf, with head spacing from 40' to 65' (12 to 20 m).

The ProSport® comes standard with a unique triple nozzle configuration, consisting of a primary nozzle for long distance and two secondary nozzles for mid-range and short distance coverage. This nozzle design provides superior, close-in water distribution from 45' to 77' (13 to 23 m).

Available in a high speed version, ideal for quick wet downs and dust control.



Easy Arc Setting

Arc Selection 40°
to Continuous 360°
Adjust From Left Start

Features and Benefits







- **Revolutionary Patented Top Arc Set** – Simplified arc set allows for wet or dry adjustment in seconds.
- **Triple Nozzle Configuration** – Ensures even distribution of water.
- **2 in 1 Adjustable or Continuous Rotation** – Provides a full range of adjustment from 40° to a continuous full circle.
- **Top Arc Set Degree Markings** – Clearly indicates the current watering pattern and simplifies arc set adjustment.
- **Arc Memory Clutch** – Prevents internal gear damage and returns rotor to its prior setting automatically if nozzle turret is forced past stop.
- **Time Proven Patented Reversing Mechanism** – Assures continuous reverse and return...over a 35 year history.
- **Heavy Duty Rubber Cover and Mud Guard** – Protects against physical injury and reduces liability, allows sprinkler to be installed below grade.
- **Factory Installed Check Valve** – Prevents low head drainage.

Specifications







- Inlet: 1" (2,5 cm) Threaded NPT Domestic
1" (2,5 cm) Threaded BSP International
- Arc Adjustment Range: 40° to Continuous 360°
- Flow Range: 5.1 – 32.5 GPM (19,3 a 123 LPM)
- Pressure Rating: 40 – 90 PSI (2,8 a 6,2 bar)
- Precipitation Rate: .48 – 1.56 in/hr (12,2 – 39 mm/hr)
(Depending on Spacing & Nozzle Used)
- Overall Height (Popped Down): 9 1/2" (24,1 cm)
- Recommended Spacing: 40' – 65' (12,2 a 19,8 m)
- Radius: 45' – 77' (13 a 23 m)
- Nozzle Trajectory: 26°
- Riser Height: 4" (10,2 cm)

Visit our Sport Field Designs online at:
www.krain.com/sport-field-design

Performance Data - Model 14003

NOZZLE	PRESSURE			RADIUS		FLOW RATE			PRECIP in/hr		PRECIP mm/hr	
	PSI	kPa	Bars	Ft.	M.	GPM	L/M	M ³ /H	■	▲	■	▲
	40	276	2,8	45'	13,7	5.1	19,3	1,2	0.48	0.58	12	14
	50	345	3,5	47'	14,3	5.9	22,3	1,3	0.51	0.62	13	15
	60	414	4,1	47'	14,3	6.5	24,6	1,5	0.57	0.68	14	17
	70	483	4,8	49'	14,9	7.1	26,9	1,6	0.57	0.68	15	17
#10 Pre-installed 	50	345	3,5	53'	16,2	10.6	40,1	2,4	0.73	0.87	18	21
	60	414	4,1	53'	15,9	11.8	44,7	2,7	0.81	0.97	21	24
	70	483	4,8	53'	16,2	12.6	47,7	2,9	0.86	1.04	22	25
	80	552	5,5	55'	16,8	13.5	51,1	3,1	0.86	1.03	22	25
#15 	50	345	3,5	57'	17,4	13.0	49,2	3,0	0.77	0.92	19	23
	60	414	4,1	59'	18,0	14.2	53,8	3,2	0.79	0.94	20	23
	70	483	4,8	59'	18,0	15.4	58,3	3,5	0.85	1.02	22	25
	80	552	5,5	63'	19,2	16.5	62,5	3,8	0.80	0.96	20	23
#20 	60	414	4,1	65'	19,8	18.9	71,5	4,3	0.86	1.03	22	25
	70	483	4,8	67'	20,4	20.5	77,6	4,7	0.88	1.06	22	26
	80	552	5,5	69'	21,0	21.9	82,9	5,0	0.89	1.06	23	26
	90	621	6,2	71'	21,6	23.2	87,8	5,3	0.89	1.06	23	26
#25 	60	414	4,1	67'	20,4	22.8	86,3	5,2	0.98	1.17	25	29
	70	483	4,8	71'	21,6	24.8	93,9	5,6	0.95	1.14	24	28
	80	552	5,5	75'	22,9	26.5	100,3	6,0	0.91	1.09	23	27
	90	621	6,2	77'	23,5	26.8	101,4	6,1	0.87	1.04	22	25
#30 	60	414	4,1	67'	20,4	23.7	89,7	5,4	1.02	1.22	26	30
	70	483	4,8	69'	21,0	25.6	96,9	5,8	1.04	1.24	26	30
	80	552	5,5	69'	21,0	27.5	104,1	6,3	1.11	1.33	28	33
	90	621	6,2	71'	21,6	29.2	110,5	6,6	1.12	1.34	28	33

Performance Data - Model 14053

NOZZLE	PRESSURE			RADIUS		FLOW RATE			PRECIP in/hr		PRECIP mm/hr	
	PSI	kPa	Bars	Ft.	M.	GPM	L/M	M ³ /H	■	▲	■	▲
	40	276	2,8	43'	13,1	5.9	22,3	1,3	0.61	0.71	16	18
	50	345	3,5	44'	13,4	6.2	23,5	1,4	0.62	0.71	16	18
	60	414	4,1	45'	13,7	6.4	24,2	1,5	0.61	0.70	15	18
	70	483	4,8	45'	13,7	7.6	28,8	1,7	0.72	0.83	18	21
#10 Pre-installed 	50	345	3,5	49'	14,9	10.6	40,1	2,4	0.85	0.98	22	25
	60	414	4,1	53'	15,8	11.5	44,3	2,7	0.79	0.91	21	25
	70	483	4,8	53'	16,1	13.3	50,3	3,0	0.91	1.05	23	27
	80	552	5,5	54'	16,5	14.0	53,0	3,2	0.92	1.07	23	27
#15 	50	345	3,5	52'	15,8	12.4	46,9	2,8	0.88	1.02	23	26
	60	414	4,1	54'	16,5	13.6	55,3	3,3	0.90	1.04	24	28
	70	483	4,8	56'	17,1	14.6	58,7	3,5	0.90	1.03	24	28
	80	552	5,5	58'	17,1	15.9	60,2	3,6	0.91	1.05	23	27
#20 	60	414	4,1	56'	17,1	19.8	66,2	4,0	1.22	1.40	27	31
	70	483	4,8	58'	17,7	21.2	71,5	4,3	1.21	1.40	27	32
	80	552	5,5	59'	18,0	22.8	78,7	4,7	1.26	1.46	29	34
	90	621	6,2	60'	18,3	24.4	82,1	4,9	1.30	1.51	29	34
#25 	60	414	4,1	59'	18,0	22.4	84,8	5,1	1.24	1.43	31	36
	70	483	4,8	66'	20,1	25.7	97,3	5,8	1.14	1.31	29	33
	80	552	5,5	67'	20,4	27.8	105,2	6,3	1.19	1.38	30	35
	90	621	6,2	68'	20,7	29.9	113,2	6,8	1.24	1.44	32	37
#30 	60	414	4,1	60'	18,3	25.2	95,4	5,7	1.35	1.56	34	39
	70	483	4,8	72'	22,0	28.5	107,9	6,5	1.06	1.22	27	31
	80	552	5,5	73'	22,2	30.8	116,6	7,0	1.11	1.28	28	33
	90	621	6,2	75'	22,9	32.5	123,0	7,4	1.11	1.28	28	33

*All precipitation rates calculated for 180° operation. For the precipitation rate for a 360° sprinkler, divide by 2.

Models

- 14003 ProSport® Plastic
- 14053 ProSport® High Speed Plastic

OTHER OPTIONS: ADD TO PART NUMBER

- SS Stainless Steel
- BSP w/BSP Thread
- NN No Nozzle
- RCW Reclaimed Water Use





PRO-S™ SPRAYS

Application: Residential / Commercial

The Pro-S™ Spray is designed to provide long life and outstanding performance.

The result of precision engineering and extensive field testing by contractors around the world, the Pro-S™ Spray is built with the contractor in mind.

These sprays are distinguished by robust construction, rugged body and cap, co-molded seal and heavy-duty retraction spring. The co-molded wiper seal ensures proper operation time after time with minimal flow by. Save water & eliminate misting and low head drainage with Pro-S™ Spray CV-PR model.

Assembly fits in a Rain Bird® 1800 Series spray body. Accepts all female threaded nozzles.



Features and Benefits

- **Co-Molded Wiper Seal** – Ensures a leak free, full pop-up operation even under low-pressure situations. Cartridge design allows for easy removal and cleaning. Treated with UV inhibitors for long life. Seal material was carefully selected to reduce degradation and stick-ups.
- **Accepts Female Threaded Nozzles.**
- **Ratcheting Riser** – Permits quick, easy alignment of spray pattern.
- **Heavy-Duty Retraction Spring** – Strongest spring in the industry for positive retraction in all soil conditions.
- **Side Inlet** – Standard on 12" (30,5 cm) model. Optional on 6" model (15,3 cm).
- **Wide Selection of Sizes** – Available in 2", 3", 4", 6" and 12" (5, 7,5, 10, 15 and 30,5 cm) models.
- **Pre-Installed Flush Cap.**
- **Optional In-stem Pressure Regulator** – Available for 4", 6" and 12" (10, 15 and 30,5 cm) models, factory preset at 40 psi (2,8 bar).
- **Optional In-stem Check Valve** – Pre-installed or installs in the field, holds up to 10' (3 m) of head pressure.
- **Optional Pre-installed Nozzle Guard.**
- **Fits in Rain Bird® 1800 Can.**
- **Most pressure regulated Pro-S™ Sprays are EPA WaterSense certified.** For a full list, visit our website at: www.krain.com/watersense-certified



Specifications

- Pressure Rating: 20 – 70 PSI (1,4 – 4,8 bar)
- Flow-by: 0 – 8 psi (0,6 bar) 0.20 GPM (0,76 LPM)
- Inlet: 1/2" (1,3 cm) Female Thread NPT
- Overall Body Height:

78002 – 4"	(10 cm)
78003 – 4 7/8"	(12,4 cm)
78004 – 6"	(15 cm)
78006 – 9 3/8"	(23,4 cm)
78012 – 16"	(40,7 cm)

Models

- 78002 PRO-S™ 2" Pop-up (5 cm)**
- 78003 PRO-S™ 3" Pop-up (7,5 cm)**
- 78004 PRO-S™ 4" Pop-up (10 cm)**
- 78006 PRO-S™ 6" Pop-up with side inlet (15 cm)**
- 78012 PRO-S™ 12" Pop-up (30 cm)**

Other options add to part number:

- CV Check Valve
- GUARD Nozzle Guard
- NSI No Side Inlet (6" (15 cm) only)
- PR30 Pressure Regulator 4", 6" and 12" (10, 15, and 30,5 cm) regulates to 30 PSI (2,1 bar)
- PR40 Pressure Regulator 4", 6" and 12" (10, 15, and 30,5 cm) regulates to 40 PSI (2,8 bar)
- RCW Reclaimed Water Use
- CV-PR30 Pressure Regulator with Check Valve regulates to 30 PSI (2,1 bar)
- CV-PR40 Pressure Regulator with Check Valve regulates to 40 PSI (2,8) bar
- SF Stop Flow™

Co-Molded Wiper Seal

Ensures leak free, full pop-up operation even under low-pressure situations. Seal material was carefully selected to reduce degradation and stick-ups.



Stop Flow™

Automatically stops water flow should a nozzle get damaged.



OPTIONAL FEATURES

In-stem Pressure Regulator



Saves water by properly regulating nozzle operating pressure. Aids in eliminating misting, fogging and overspray due to wind drift. Regulates pressure to 30 PSI (2,1 bar) or 40 PSI (2,8 bar).

Pad printed CV-PR

Makes the Pro-S™ CV-PR easily identified in the field after installation.

Nozzle Guard

Provides extra protection to Rotary or standard nozzles.





NP SPRAYS™

Application: Residential / Commercial

NP Sprays™ are ideal for watering smaller areas, ground cover and shrub areas.

NP pop-up sprays are built with the contractor in mind. With the narrow profile, replacement is effortless. The durable seal ensures leak-free operation and extends product life.



Models

- NP2 2" (5 cm) Narrow Profile Spray Body
- NP4 4" (10 cm) Narrow Profile Spray Body

Other options add to part number:

- CV Check Valve

Features and Benefits

- Available in 2" (5 cm) and 4" (10 cm) Models – Provides flexibility in system design.
- Accepts Female Threaded Nozzles.
- Stainless Steel Retraction Spring – Provides reliable retraction of the riser in all soil conditions.
- Ratcheting Riser – Allows for easy pattern alignment by turning the riser.
- Narrow Profile Body – Easy to retrofit with existing systems.

Specifications

- Pressure Rating: 20 – 50 PSI (1,4 – 3,5 bars)
- Inlet: 1/2" (1,3 cm) NPT Male Thread
- Overall Body Height:
 - NP2 – 2" (5 cm)
 - NP4 – 4" (10 cm)

K-SPRAYS™

Application: Residential / Commercial



The K-Spray™ line offers system versatility with a wide range of pop-up heights suited for many applications.

From small flower beds to residential and light commercial lawns and planted areas, the K-Spray™ line has the pop-up height for the job. Manufactured with time-tested UV-resistant plastic and corrosion resistant stainless steel parts for long product life and reliability.

Models

73001	3" (7,6 cm) Pop-Up
74001	4" (10 cm) Pop-Up
76001	6" (15 cm) Pop-Up
71201	12" (30,5 cm) Pop-Up

Other Options: Add to Part Number

-RCW	Reclaimed Water Use/Purple Cap
-CV	Check Valve

Features and Benefits

- Available in 3", 4", 6" and 12" (7,6, 10, 15, 30,5 cm) Models – Provides flexibility in system design.
- Accepts Male Threaded Nozzles.
- Stainless Steel Retraction Spring** – Provides reliable retraction of the riser in all soil conditions.
- Ratcheting Riser** – Allows for easy pattern alignment by turning the riser.
- Heavy Duty Wiper Seal** – Ensures leak free, full pop-up operation even under low-pressure situations.
- Optional Water-Saving Check Valve** – Eliminates low head drainage.
- Optional Purple Cap for Reclaimed Water Use** – Highly visible for identification of RCW systems.

Specifications

- Pressure Rating: 20 – 50 PSI (1,4 – 3,5 bars)
- Inlet: 1/2" (1,3 cm) NPT Female Thread
- Overall Body Height:

73001 – 3" (7,6 cm)	76001 – 6" (15 cm)
74001 – 4" (10 cm)	71201 – 12" (30,5 cm)





ROTARY NOZZLE SERIES

Application: Residential / Commercial

Full rotary nozzle design versatility allows the contractor to carry fewer nozzles in their trucks.

The 90° – 270° adjustable arc will fulfill 80% – 90% of all arc adjustments usually required! The full 360° and specialty models complete the variety of pattern options.



Models

RN100 ADJ-90-270

90°-270° Adjustable, 13' – 15'
(4 – 4,6 m), Medium Green

RN100 FIX 360

360° Fixed Pattern, 13' – 15'
(4 – 4,6 m), Light Green

RN200 ADJ-90-270

90°-270° Adjustable, 16' – 19'
(4,9 – 5,8 m), Medium Blue

RN200 FIX 360

Fixed Pattern 360°, 16' – 19'
(4,9 – 5,8 m), Light Blue

RN300 ADJ-90-270

90°-270° Adjustable, 26' – 27'
(7,9 – 9,1 m), Medium Grey

RN300 FIX 360

360° Fixed Pattern, 26' – 30'
(7,9 – 9,1 m), Light Grey

RNS-RES-515

Right End Strip, Burnt Orange

RNS-LES-515

Left End Strip, Olive

RNS-SS-530

Side Strip, Brown

Features and Benefits

- **Durable Design** – Molded with high-impact engineered resin for long life.
- **Superior Uniformity** – Multi-stream technology provides outstanding coverage eliminating brown spots.
- **Matched Precipitation** – Low precipitation rate is proportionate even after arc and radius adjustment.
- **Water-smart Technology** – Reduce water usage up to 30% without compromising on results.
- **Double pop-up Design** – Delivers additional protection from dirt/particulate intrusion in harsh conditions.
- **Simple to Adjust** – Easiest adjustment in the industry.
- **Color-Coded** – Easily identify 6 standard nozzles and 3 specialty nozzles in the field.

Performance Data - Adjustable and Fixed Patterns

RN100-ADJ-90-270 (MEDIUM GREEN)

ARC	PRESSURE			RADIUS		FLOW RATE			PRECIP in/hr		PRECIP mm/hr	
	PSI	kPa	Bars	Ft.	M.	GPM	L/M	M ³ /H	■	▲	■	▲
90°	30	207	2.07	13	3.97	0.22	0.83	0.05	0.50	0.58	13	15
	35	241	2.41	14	4.27	0.24	0.91	0.05	0.47	0.54	12	14
	40	276	2.76	14	4.27	0.25	0.95	0.06	0.49	0.57	12	14
	45	310	3.10	15	4.58	0.28	1.06	0.06	0.48	0.55	12	14
	50	345	3.45	15	4.58	0.30	1.14	0.07	0.51	0.59	13	15
180°	30	207	2.07	13	3.97	0.44	1.67	0.10	0.50	0.58	13	15
	35	241	2.41	14	4.27	0.47	1.78	0.11	0.46	0.53	12	14
	40	276	2.76	14	4.27	0.50	1.89	0.11	0.49	0.57	12	14
	45	310	3.10	15	4.58	0.58	2.20	0.13	0.50	0.57	13	15
	50	345	3.45	15	4.58	0.60	2.27	0.14	0.51	0.59	13	15
270°	30	207	2.07	13	3.97	0.66	2.50	0.15	0.50	0.58	13	15
	35	241	2.41	14	4.27	0.71	2.69	0.16	0.46	0.54	12	14
	40	276	2.76	14	4.27	0.75	2.84	0.17	0.49	0.57	12	14
	45	310	3.10	15	4.58	0.88	3.33	0.20	0.50	0.58	13	15
	50	345	3.45	15	4.58	0.90	3.41	0.20	0.51	0.59	13	15

RN100-FIX360 (LIGHT GREEN)

ARC	PRESSURE			RADIUS		FLOW RATE			PRECIP in/hr		PRECIP mm/hr	
	PSI	kPa	Bars	Ft.	M.	GPM	L/M	M ³ /H	■	▲	■	▲
360°	30	207	2.07	13	3.97	0.88	3.33	0.20	0.50	0.58	13	15
	35	241	2.41	14	4.27	0.94	3.56	0.21	0.46	0.53	12	14
	40	276	2.76	14	4.27	1.00	3.79	0.23	0.49	0.57	12	14
	45	310	3.10	15	4.58	1.15	4.35	0.26	0.49	0.57	12	14
	50	345	3.45	15	4.58	1.20	4.54	0.27	0.51	0.59	13	15

*Data represents test results in zero wind. Adjust for local conditions.

Performance Data - Adjustable and Fixed Patterns

RN200-ADJ-90-270 (MEDIUM BLUE)

ARC	PRESSURE			RADIUS		FLOW RATE			PRECIP in/hr		PRECIP mm/hr	
	PSI	kPa	Bars	Ft.	M.	GPM	L/M	M ³ /H	■	▲	■	▲
90°	30	207	2.07	16	4.88	0.34	1.29	0.08	0.51	0.59	13	15
	35	241	2.41	17	5.19	0.38	1.44	0.09	0.51	0.58	13	15
	40	276	2.76	18	5.49	0.41	1.55	0.09	0.49	0.56	12	14
	45	310	3.10	19	5.80	0.42	1.59	0.10	0.45	0.52	11	13
	50	345	3.45	19	5.80	0.47	1.78	0.11	0.50	0.58	13	15
180°	30	207	2.07	16	4.88	0.67	2.54	0.15	0.50	0.58	13	15
	35	241	2.41	17	5.19	0.75	2.84	0.17	0.50	0.58	13	15
	40	276	2.76	18	5.49	0.83	3.14	0.19	0.49	0.57	13	14
	45	310	3.10	19	5.80	0.84	3.18	0.19	0.45	0.52	11	13
	50	345	3.45	19	5.80	0.94	3.56	0.21	0.50	0.58	13	15
270°	30	207	2.07	16	4.88	1.01	3.82	0.23	0.51	0.58	13	15
	35	241	2.41	17	5.19	1.13	4.28	0.26	0.50	0.58	13	15
	40	276	2.76	18	5.49	1.24	4.69	0.28	0.49	0.57	12	14
	45	310	3.10	18	5.49	1.26	4.77	0.29	0.50	0.58	13	15
	50	345	3.45	19	5.80	1.41	5.34	0.32	0.50	0.58	13	15

RN200-FIX360 (LIGHT BLUE)

ARC	PRESSURE			RADIUS		FLOW RATE			PRECIP in/hr		PRECIP mm/hr	
	PSI	kPa	Bars	Ft.	M.	GPM	L/M	M ³ /H	■	▲	■	▲
360°	30	207	2.07	16	4.88	1.34	5.07	0.30	0.50	0.58	13	15
	35	241	2.41	17	5.19	1.50	5.68	0.34	0.50	0.58	13	15
	40	276	2.76	18	5.49	1.65	6.25	0.37	0.49	0.57	12	14
	45	310	3.10	19	5.80	1.68	6.36	0.38	0.45	0.52	11	13
	50	345	3.45	19	5.80	1.88	7.12	0.43	0.50	0.58	13	15



RN300-ADJ-90-270 (MEDIUM GREY)

ARC	PRESSURE			RADIUS		FLOW RATE			PRECIP in/hr		PRECIP mm/hr	
	PSI	kPa	Bars	Ft.	M.	GPM	L/M	M ³ /H	■	▲	■	▲
90°	30	207	2.07	26	7.93	0.80	3.03	0.18	0.46	0.53	12	13
	35	241	2.41	26	7.93	0.85	3.22	0.19	0.48	0.56	12	14
	40	276	2.76	27	8.24	0.90	3.41	0.20	0.48	0.55	12	14
	45	310	3.10	28	8.54	0.95	3.60	0.22	0.47	0.54	12	14
	50	345	3.45	28	8.54	1.00	3.79	0.23	0.49	0.57	12	14
180°	30	207	2.07	26	7.93	1.40	5.30	0.32	0.40	0.46	10	12
	35	241	2.41	27	8.24	1.50	5.68	0.34	0.40	0.46	10	12
	40	276	2.76	27	8.24	1.60	6.06	0.36	0.42	0.49	11	12
	45	310	3.10	29	8.85	1.70	6.44	0.39	0.39	0.45	10	11
	50	345	3.45	30	9.15	1.80	6.81	0.41	0.39	0.44	10	11
270°	30	207	2.07	26	7.93	2.45	9.27	0.56	0.47	0.54	12	14
	35	241	2.41	27	8.24	2.55	9.65	0.58	0.45	0.52	11	13
	40	276	2.76	28	8.54	2.75	10.41	0.62	0.45	0.52	11	13
	45	310	3.10	28	8.54	2.90	10.98	0.66	0.47	0.55	12	14
	50	345	3.45	27	8.24	3.10	11.73	0.70	0.55	0.63	14	16

RN300-FIX360 (LIGHT GREY)

ARC	PRESSURE			RADIUS		FLOW RATE			PRECIP in/hr		PRECIP mm/hr	
	PSI	kPa	Bars	Ft.	M.	GPM	L/M	M ³ /H	■	▲	■	▲
360°	30	207	2.07	26	7.93	3.10	11.73	0.70	0.44	0.51	11	13
	35	241	2.41	27	8.24	3.20	12.11	0.73	0.42	0.49	11	12
	40	276	2.76	28	8.54	3.50	13.25	0.79	0.43	0.50	11	13
	45	310	3.10	28	8.54	3.55	13.44	0.81	0.44	0.50	11	13
	50	345	3.45	30	9.15	3.70	14.01	0.84	0.40	0.46	10	12

Performance Data - Special Patterns

PATTERN	NOZZLE	PRESSURE			WIDTH X LENGTH		FLOW RATE	
		PSI	kPa	Bars	Feet	Meters	GPM	L/M
Right End Strip 	RNS-RES-515 Burnt Orange	30	206	2,06	4 x 15	1.22 x 4.6	0.30	1,14
		35	246	2,46	5 x 15	1.5 x 4.6	0.32	1,21
		40	275	2,75	5 x 15	1.5 x 4.6	0.35	1,32
		45	310	3,10	6 x 16	1.8 x 4.9	0.38	1,43
		50	345	3,45	6 x 16	1.8 x 4.9	0.40	1,51
Left End Strip 	RNS-LES-515 Olive	30	206	2,06	4 x 15	1.22 x 4.6	0.30	1,14
		35	246	2,46	5 x 15	1.5 x 4.6	0.32	1,21
		40	275	2,75	5 x 15	1.5 x 4.6	0.35	1,32
		45	310	3,10	6 x 15	1.8 x 4.6	0.38	1,43
		50	345	3,45	6 x 16	1.8 x 4.9	0.40	1,51
Side Strip 	RNS-SS-530 Brown	30	206	2,06	4 x 29	1.22 x 8.8	0.50	1,80
		35	246	2,46	5 x 30	1.5 x 9.1	0.55	2,08
		40	275	2,75	5 x 30	1.5 x 9.1	0.60	2,30
		45	310	3,10	6 x 31	1.8 x 9.4	0.65	2,46
		50	345	3,45	7 x 32	2.1 x 9.7	0.70	2,64

*Data represents test results in zero wind. Adjust for local conditions.





FULLY ADJUSTABLE ROTARY NOZZLE

Application: Residential / Commercial

Achieve the healthiest lawn and landscape while saving water and money. No tools required!

A recognized water conserving tool, the K-Rain® Fully Adjustable Nozzles use up to 30% less water and are eligible for conservation rebates and incentives in many areas. Check with your local water utility for information.

No other nozzle on the market today is fully adjustable from 80° to 360° degrees offering maximum flexibility in system design and eliminating the need for multiple nozzles. One nozzle does it all.



Models

RN100-ADJ (Green)

80°-360° Adjustable
13' – 15' (4 – 4,6 m)

RN200-ADJ (Blue)

80°-360° Adjustable
16' – 19' (4,9 – 5,8 m)

RN300-ADJ (Red)

80°-360° Adjustable
26' – 30' (7,9 – 9,1 m)



Scan QR code
to view video

Features and Benefits

- **Fully adjustable 80° to 360°** – only one SKU per distance
- **Female Threaded** – replaces all female thread nozzles
- **Hand adjustable** – no tools needed
- **Radius adjustment up to 30%** – no tools needed
- **25% radius reduction** – patented flow control
- **Arc adjustment wet or dry** – visual left start and right stop
- **Double pop up system** – superior dirt tolerance
- **Speed rotation control** – silicon grease
- **Three model options** – distances from 13' to 28' (3.96m to 8.53m)
- **Matched precipitation** – superior efficiency in water and uniformity through all patterns and distances
- **Low precipitation rate** – reduces runoff and improves soil absorption
- **Low flow rate** – allows for more heads per zone, fewer zones
- **Viscous dampening** – ensures consistent application speed over varying flow rates and pressure ranges
- **Multiple stream technology** – for improved wind resistance
- **Large filter** – prolongs product life
- **Can be installed in the same zone as rotors**
- **Two year limited warranty**

Performance Data

RN100-ADJ

ARC	PRESSURE		RADIUS		FLOW RATE		PRECIPITATION			
	PSI	Bars	Ft.	M.	GPM	L/M	■ in/hr ▲	■ mm/hr ▲		
90°	30	2.07	13	3.96	0.22	0.83	0.50	0.58	11	12
	40	2.76	14	4.27	0.25	0.95	0.49	0.57	10	12
	50	3.45	15	4.57	0.30	1.14	0.51	0.59	11	12
180°	30	2.07	13	3.96	0.44	1.67	0.50	0.58	11	12
	40	2.76	14	4.27	0.50	1.89	0.49	0.57	10	12
	50	3.45	15	4.57	0.60	2.27	0.51	0.59	11	12
360°	30	2.07	13	3.96	0.90	3.41	0.51	0.59	11	12
	40	2.76	14	4.27	1.00	3.79	0.49	0.57	10	12
	50	3.45	15	4.57	1.20	4.54	0.51	0.59	11	12

RN200-ADJ

ARC	PRESSURE		RADIUS		FLOW RATE		PRECIPITATION			
	PSI	Bars	Ft.	M.	GPM	L/M	■ in/hr ▲	■ mm/hr ▲		
90°	30	2.07	16	4.88	0.34	1.29	0.51	0.59	11	12
	40	2.76	18	5.49	0.41	1.55	0.49	0.56	10	12
	50	3.45	19	5.79	0.47	1.78	0.50	0.58	11	12
180°	30	2.07	16	4.88	0.67	2.54	0.50	0.58	11	12
	40	2.76	18	5.49	0.83	3.14	0.49	0.57	10	12
	50	3.45	19	5.79	0.94	3.56	0.50	0.58	11	12
360°	30	2.07	16	4.88	1.35	5.11	0.51	0.59	11	12
	40	2.76	18	5.49	1.70	6.44	0.51	0.58	11	12
	50	3.45	19	5.79	1.90	7.19	0.51	0.58	11	12

RN300-ADJ

ARC	PRESSURE		RADIUS		FLOW RATE		PRECIPITATION			
	PSI	Bars	Ft.	M.	GPM	L/M	■ in/hr ▲	■ mm/hr ▲		
90°	30	2.07	26	7.92	0.80	3.03	0.46	0.53	10	11
	40	2.76	27	8.23	0.90	3.41	0.48	0.55	10	12
	50	3.45	29	8.84	1.00	3.79	0.46	0.53	10	11
180°	30	2.07	26	7.92	1.50	5.68	0.43	0.49	9	10
	40	2.76	27	8.23	1.60	6.06	0.42	0.49	9	10
	50	3.45	29	8.84	1.80	6.81	0.41	0.48	9	10
360°	30	2.07	26	7.92	3.00	11.36	0.43	0.49	9	10
	40	2.76	27	8.23	3.20	12.11	0.42	0.49	9	10
	50	3.45	28	8.53	3.80	14.38	0.47	0.54	10	11

*Data represents test results in zero wind. Adjust for local conditions.

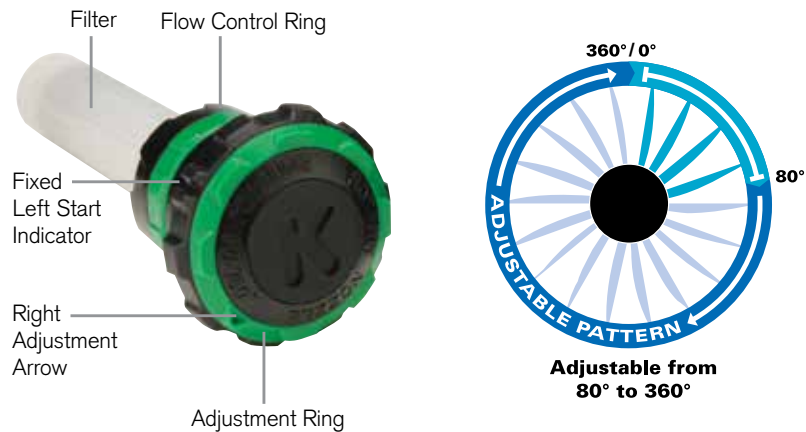



HE KVF ADJ. NOZZLES

High Efficiency Nozzles

Application: Residential / Commercial

K-Rain® High Efficiency KVF nozzles bring complete flexibility to contractors working with sprays in a variety of terrains.

These fully adjustable, female threaded nozzles fit the K-Rain® Pro-S™ series and NP Spray™ bodies, as well as any other male threaded spray body on the market. Choose from 8', 10', 12', 15' and 17' (2,4; 3; 3,7; 4,6 and 5,2 m) configurations.



Models

KVF8

8' (2,4 M) Nozzle,
Green

KVF10

10' (3 M) Nozzle,
Blue

KVF12

12' (3,7 M) Nozzle,
Brown

KVF15

15' (4,6 M) Nozzle,
Black

KVF17

17' (5,2 M) Nozzle,
Grey

Performance Data

KVF-8 8' (2,4 M) NOZZLE (GREEN)

ARC	PRESSURE			RADIUS		FLOW RATE			PRECIP in/hr		PRECIP mm/hr	
	PSI	kPa	Bars	Ft.	M.	GPM	L/M	M³/H	■	▲	■	▲
90°	20	138	1.38	9	2.7	0.39	1.48	0.09	1.85	2.14	47	54
	25	172	1.72	10	3.1	0.42	1.59	0.10	1.62	1.87	41	47
	30	207	2.07	10	3.1	0.50	1.89	0.11	1.93	2.22	49	56
	40	276	2.76	11	3.4	0.61	2.31	0.14	1.94	2.24	49	57
180°	20	138	1.38	9	2.7	0.75	2.84	0.17	1.78	2.06	45	52
	25	172	1.72	9	2.7	0.85	3.22	0.19	2.02	2.33	51	59
	30	207	2.07	10	3.1	1.00	3.79	0.23	1.93	2.22	49	56
	40	276	2.76	10	3.1	1.16	4.39	0.26	2.23	2.58	57	65
270°	20	138	1.38	9	2.7	1.15	4.35	0.26	1.82	2.10	46	53
	25	172	1.72	9	2.7	1.25	4.73	0.28	1.98	2.29	50	58
	30	207	2.07	10	3.1	1.50	5.68	0.34	1.93	2.22	49	56
	40	276	2.76	10	3.1	1.75	6.62	0.40	2.25	2.59	57	66
360°	20	138	1.38	9	2.7	1.50	5.68	0.34	1.78	2.06	45	52
	25	172	1.72	9	2.7	1.70	6.44	0.39	2.02	2.33	51	59
	30	207	2.07	10	3.1	2.00	7.57	0.45	1.93	2.22	49	56
	40	276	2.76	10	3.1	2.30	8.71	0.52	2.21	2.56	56	65

KVF-10 10' (3 M) NOZZLE (BLUE)

ARC	PRESSURE			RADIUS		FLOW RATE			PRECIP in/hr		PRECIP mm/hr	
	PSI	kPa	Bars	Ft.	M.	GPM	L/M	M³/H	■	▲	■	▲
90°	20	138	1.38	10	3.1	0.45	1.70	0.10	1.73	2.00	44	51
	25	172	1.72	11	3.4	0.54	2.04	0.12	1.72	1.98	44	50
	30	207	2.07	12	3.7	0.62	2.35	0.14	1.66	1.91	42	49
	40	276	2.76	12	3.7	0.70	2.65	0.16	1.87	2.16	47	55
180°	20	138	1.38	10	3.1	0.90	3.41	0.20	1.73	2.00	44	51
	25	172	1.72	11	3.4	1.10	4.16	0.25	1.75	2.02	44	51
	30	207	2.07	12	3.7	1.25	4.73	0.28	1.67	1.93	42	49
	40	276	2.76	12	3.7	1.40	5.30	0.32	1.87	2.16	47	55
270°	20	138	1.38	10	3.1	1.35	5.11	0.31	1.73	2.00	44	51
	25	172	1.72	11	3.4	1.65	6.25	0.37	1.75	2.02	44	51
	30	207	2.07	12	3.7	1.85	7.00	0.42	1.65	1.90	42	48
	40	276	2.76	12	3.7	2.10	7.95	0.48	1.87	2.16	47	55
360°	20	138	1.38	10	3.1	1.80	6.81	0.41	1.73	2.00	44	51
	25	172	1.72	11	3.4	2.20	8.33	0.50	1.75	2.02	44	51
	30	207	2.07	12	3.7	2.50	9.46	0.57	1.67	1.93	42	49
	40	276	2.76	12	3.7	2.80	10.60	0.64	1.87	2.16	47	55

*Data represents test results in zero wind. Radius may be reduced with the nozzle retention screw.
Bold = recommended pressure.

Features and Benefits

- Superior Spray Patterns.
- Color-coded for Easy Identification.
- Uniform Water Distribution.
- Water Efficient Low Flow Rates.
- Extra Long Filters Extend Time Between Cleanings.

Performance Data (con't)

KVF-12 12' (3,7 M) NOZZLE (BROWN)

ARC	PRESSURE			RADIUS		FLOW RATE			PRECIP in/hr		PRECIP mm/hr	
	PSI	kPa	Bars	Ft.	M.	GPM	L/M	M ³ /H	■	▲	■	▲
90°	20	138	1.38	12	3.7	0.65	2.46	0.15	1.74	2.01	44	51
	25	172	1.72	13	4.0	0.70	2.65	0.16	1.59	1.84	40	47
	30	207	2.07	14	4.3	0.80	3.03	0.18	1.57	1.81	40	46
	40	276	2.76	14	4.3	0.90	3.41	0.20	1.77	2.04	45	52
180°	20	138	1.38	12	3.7	1.30	4.92	0.30	1.74	2.01	44	51
	25	172	1.72	13	4.0	1.40	5.30	0.32	1.59	1.84	40	47
	30	207	2.07	14	4.3	1.60	6.06	0.36	1.57	1.81	40	46
	40	276	2.76	14	4.3	1.80	6.81	0.41	1.77	2.04	45	52
270°	20	138	1.38	12	3.7	1.90	7.19	0.43	1.69	1.96	43	50
	25	172	1.72	13	4.0	2.10	7.95	0.48	1.59	1.84	40	47
	30	207	2.07	14	4.3	2.40	9.08	0.55	1.57	1.81	40	46
	40	276	2.76	14	4.3	2.60	9.84	0.59	1.70	1.97	43	50
360°	20	138	1.38	12	3.7	2.20	8.33	0.50	1.47	1.70	37	43
	25	172	1.72	13	4.0	2.60	9.84	0.59	1.48	1.71	38	43
	30	207	2.07	14	4.3	3.10	11.73	0.70	1.52	1.76	39	45
	40	276	2.76	14	4.3	3.50	13.25	0.79	1.72	1.98	44	50

KVF-15 15' (4,6 M) NOZZLE (BLACK)

ARC	PRESSURE			RADIUS		FLOW RATE			PRECIP in/hr		PRECIP mm/hr	
	PSI	kPa	Bars	Ft.	M.	GPM	L/M	M ³ /H	■	▲	■	▲
90°	20	138	1.38	14	4.3	0.75	2.84	0.17	1.47	1.70	37	43
	25	172	1.72	15	4.6	0.85	3.22	0.19	1.45	1.68	37	43
	30	207	2.07	15	4.6	0.95	3.60	0.22	1.63	1.88	41	48
	40	276	2.76	17	5.2	1.10	4.16	0.25	1.47	1.69	37	43
180°	20	138	1.38	14	4.3	1.40	5.30	0.32	1.38	1.59	35	40
	25	172	1.72	15	4.6	1.70	6.44	0.39	1.45	1.68	37	43
	30	207	2.07	15	4.6	1.90	7.19	0.43	1.63	1.88	41	48
	40	276	2.76	17	5.2	2.30	8.71	0.52	1.53	1.77	39	45
270°	20	138	1.38	14	4.3	2.25	8.52	0.51	1.47	1.70	37	43
	25	172	1.72	15	4.6	2.55	9.65	0.58	1.45	1.68	37	43
	30	207	2.07	15	4.6	2.80	10.60	0.64	1.60	1.84	41	47
	40	276	2.76	17	5.2	3.40	12.87	0.77	1.51	1.74	38	44
360°	20	138	1.38	14	4.3	3.00	11.36	0.68	1.47	1.70	37	43
	25	172	1.72	15	4.6	3.40	12.87	0.77	1.45	1.68	37	43
	30	207	2.07	15	4.6	3.80	14.38	0.86	1.63	1.88	41	48
	40	276	2.76	17	5.2	4.60	17.41	1.04	1.53	1.77	39	45

KVF-17 17' (5,2 M) NOZZLE (GREY)

ARC	PRESSURE			RADIUS		FLOW RATE			PRECIP in/hr		PRECIP mm/hr	
	PSI	kPa	Bars	Ft.	M.	GPM	L/M	M ³ /H	■	▲	■	▲
90°	20	138	1.38	17	5.2	0.85	3.22	0.19	1.13	1.31	29	33
	25	172	1.72	17	5.2	0.95	3.60	0.22	1.27	1.46	32	37
	30	207	2.07	18	5.5	1.05	3.97	0.24	1.25	1.44	32	37
	40	276	2.76	18	5.5	1.20	4.54	0.27	1.43	1.65	36	42
180°	20	138	1.38	16	4.9	1.70	6.44	0.39	1.28	1.48	32	37
	25	172	1.72	17	5.2	1.90	7.19	0.43	1.27	1.46	32	37
	30	207	2.07	18	5.5	2.10	7.95	0.48	1.25	1.44	32	37
	40	276	2.76	18	5.5	2.40	9.08	0.55	1.43	1.65	36	42
270°	20	138	1.38	16	4.9	2.50	9.46	0.57	1.25	1.45	32	37
	25	172	1.72	17	5.2	2.80	10.60	0.64	1.24	1.44	32	36
	30	207	2.07	18	5.5	3.15	11.92	0.72	1.25	1.44	32	37
	40	276	2.76	18	5.5	3.60	13.63	0.82	1.43	1.65	36	42
360°	20	138	1.38	16	4.9	3.40	12.87	0.77	1.28	1.48	32	37
	25	172	1.72	17	5.2	3.80	14.38	0.86	1.27	1.46	32	37
	30	207	2.07	18	5.5	4.20	15.90	0.95	1.25	1.44	32	37
	40	276	2.76	18	5.5	4.80	18.17	1.09	1.43	1.65	36	42

*Data represents test results in zero wind. Radius may be reduced with the nozzle retention screw.
 Bold = recommended pressure.





KV NOZZLES

Adjustable Pattern Male Thread Nozzles

Application: Residential / Commercial



The K-Rain® KV Adjustable Nozzles have a superior spray pattern that ensures proper precipitation rates throughout the adjustment.

They have a male thread configuration to fit K-Rain K-Spray™ bodies. Extra long filters provide longer time between cleanings.

Models

KV8
8' (2,4 M) Spray,
Green

KV10
10' (3 M) Spray,
Blue

KV12
12' (3,7 M) Spray,
Brown

KV15
15' (4,6 M) Spray,
Black

KV17
17' (5,2 M) Spray,
Grey

Performance Data

KV-8 8' (2,4 M) NOZZLE (GREEN)

ARC	PRESSURE			RADIUS		FLOW RATE			PRECIP in/hr		PRECIP mm/hr	
	PSI	kPa	Bars	Ft.	M.	GPM	L/M	M ³ /H	■	▲	■	▲
90°	20	138	1.38	7	2.1	0.30	1.14	0.07	2.36	2.72	60	69
	30	207	2.07	8	2.4	0.40	1.51	0.09	2.41	2.78	61	70
	40	276	2.76	8	2.4	0.40	1.51	0.09	2.41	2.78	61	70
	50	345	3.45	9	2.7	0.40	1.51	0.09	1.90	2.20	48	56
180°	20	138	1.38	7	2.1	0.80	3.03	0.18	3.14	3.63	80	92
	30	207	2.07	8	2.4	0.90	3.41	0.20	2.71	3.13	69	79
	40	276	2.76	8	2.4	1.00	3.79	0.23	3.01	3.47	76	88
	50	345	3.45	9	2.7	1.10	4.16	0.25	2.61	3.02	66	77
270°	20	138	1.38	7	2.1	1.20	4.54	0.27	3.14	3.63	80	92
	30	207	2.07	8	2.4	1.20	4.54	0.27	2.41	2.78	61	70
	40	276	2.76	8	2.4	1.30	4.92	0.30	2.61	3.01	66	76
	50	345	3.45	9	2.7	1.50	5.68	0.34	2.38	2.74	60	70
360°	20	138	1.38	7	2.1	1.90	7.19	0.43	3.73	4.31	95	109
	30	207	2.07	8	2.4	2.00	7.57	0.45	3.01	3.47	76	88
	40	276	2.76	8	2.4	2.20	8.33	0.50	3.31	3.82	84	97
	50	345	3.45	9	2.7	2.30	8.71	0.52	2.73	3.16	69	80

KV-10 10' (3 M) NOZZLE (BLUE)

ARC	PRESSURE			RADIUS		FLOW RATE			PRECIP in/hr		PRECIP mm/hr	
	PSI	kPa	Bars	Ft.	M.	GPM	L/M	M ³ /H	■	▲	■	▲
90°	20	138	1.38	12	3.7	0.70	2.65	0.16	1.87	2.16	47	55
	30	207	2.07	12	3.7	1.10	4.16	0.25	2.94	3.40	75	86
	40	276	2.76	13	4.0	1.40	5.30	0.32	3.19	3.68	81	93
	50	345	3.45	14	4.3	1.50	5.68	0.34	2.95	3.40	75	86
180°	20	138	1.38	11	3.4	1.40	5.30	0.32	2.23	2.57	56	65
	30	207	2.07	11	3.4	1.60	6.06	0.36	2.55	2.94	65	75
	40	276	2.76	12	3.7	1.80	6.81	0.41	2.41	2.78	61	70
	50	345	3.45	13	4.0	2.00	7.57	0.45	2.28	2.63	58	67
270°	20	138	1.38	10	3.1	1.70	6.44	0.39	2.18	2.52	55	64
	30	207	2.07	10	3.1	2.00	7.57	0.45	2.57	2.96	65	75
	40	276	2.76	11	3.4	2.30	8.71	0.52	2.44	2.82	62	71
	50	345	3.45	12	3.7	2.60	9.84	0.59	2.32	2.68	59	68
360°	20	138	1.38	10	3.1	2.20	8.33	0.50	2.12	2.45	54	62
	30	207	2.07	10	3.1	2.70	10.22	0.61	2.60	3.00	66	76
	40	276	2.76	11	3.4	3.00	11.36	0.68	2.39	2.76	61	70
	50	345	3.45	12	3.7	3.50	13.25	0.79	2.34	2.70	59	69

*Data represents test results in zero wind. Adjust for local conditions. Radius may be reduced with the nozzle retention screw.

KV Nozzles with extra long filters extend time between cleanings.

Performance Data (con't)

KV-12 12' (3,7 M) NOZZLE (BROWN)

ARC	PRESSURE			RADIUS		FLOW RATE			PRECIP in/hr		PRECIP mm/hr	
	PSI	kPa	Bars	Ft.	M.	GPM	L/M	M ³ /H	■	▲	■	▲
90°	20	138	1.38	12	3.7	1.10	4.16	0.25	2.94	3.40	75	86
	30	207	2.07	13	4.0	1.30	4.92	0.30	2.96	3.42	75	87
	40	276	2.76	14	4.3	1.50	5.68	0.34	2.95	3.40	75	86
	50	345	3.45	15	4.6	1.70	6.44	0.39	2.91	3.36	74	85
180°	20	138	1.38	11	3.4	1.60	6.06	0.36	2.55	2.94	65	75
	30	207	2.07	12	3.7	1.80	6.81	0.41	2.41	2.78	61	70
	40	276	2.76	13	4.0	2.20	8.33	0.50	2.51	2.89	64	73
	50	345	3.45	14	4.3	2.40	9.08	0.55	2.36	2.72	60	69
270°	20	138	1.38	11	3.4	1.90	7.19	0.43	2.02	2.33	51	59
	30	207	2.07	12	3.7	2.40	9.08	0.55	2.14	2.47	54	63
	40	276	2.76	12	3.7	2.60	9.84	0.59	2.32	2.68	59	68
	50	345	3.45	13	4.0	3.20	12.11	0.73	2.43	2.81	62	71
360°	20	138	1.38	11	3.4	2.80	10.60	0.64	2.23	2.57	56	65
	30	207	2.07	12	3.7	3.10	11.73	0.70	2.07	2.39	53	61
	40	276	2.76	12	3.7	3.50	13.25	0.79	2.34	2.70	59	69
	50	345	3.45	13	4.0	3.90	14.76	0.89	2.22	2.56	56	65

KV-15 15' (6,6 M) NOZZLE (BLACK)

ARC	PRESSURE			RADIUS		FLOW RATE			PRECIP in/hr		PRECIP mm/hr	
	PSI	kPa	Bars	Ft.	M.	GPM	L/M	M ³ /H	■	▲	■	▲
90°	20	138	1.38	15	4.6	1.30	4.92	0.30	2.22	2.57	56	65
	30	207	2.07	17	5.2	1.60	6.06	0.36	2.13	2.46	54	62
	40	276	2.76	18	5.5	1.80	6.81	0.41	2.14	2.47	54	63
	50	345	3.45	19	5.8	2.00	7.57	0.45	2.13	2.46	54	62
180°	20	138	1.38	14	4.3	1.80	6.81	0.41	1.77	2.04	45	52
	30	207	2.07	15	4.6	2.30	8.71	0.52	1.97	2.27	50	58
	40	276	2.76	16	4.9	2.60	9.84	0.59	1.96	2.26	50	57
	50	345	3.45	18	5.5	2.80	10.60	0.64	1.66	1.92	42	49
270°	20	138	1.38	14	4.3	2.70	10.22	0.61	1.77	2.04	45	52
	30	207	2.07	15	4.6	3.20	12.11	0.73	1.83	2.11	46	53
	40	276	2.76	16	4.9	3.60	13.63	0.82	1.80	2.08	46	53
	50	345	3.45	18	5.5	4.00	15.14	0.91	1.58	1.83	40	46
360°	20	138	1.38	14	4.3	3.40	12.87	0.77	1.67	1.93	42	49
	30	207	2.07	15	4.6	4.20	15.90	0.95	1.80	2.07	46	53
	40	276	2.76	16	4.9	4.70	17.79	1.07	1.77	2.04	45	52
	50	345	3.45	16	4.9	5.30	20.06	1.20	1.99	2.30	51	58

KV-17 17' (5,2 M) NOZZLE (GREY)

ARC	PRESSURE			RADIUS		FLOW RATE			PRECIP in/hr		PRECIP mm/hr	
	PSI	kPa	Bars	Ft.	M.	GPM	L/M	M ³ /H	■	▲	■	▲
90°	20	138	1.38	18	5.5	1.70	6.44	0.39	2.02	2.33	51	59
	30	207	2.07	18	5.5	1.80	6.81	0.41	2.14	2.47	54	63
	40	276	2.76	19	5.8	2.00	7.57	0.45	2.13	2.46	54	62
	50	345	3.45	20	6.1	2.20	8.33	0.50	2.12	2.45	54	62
180°	20	138	1.38	17	5.2	1.90	7.19	0.43	1.27	1.46	32	37
	30	207	2.07	18	5.5	2.40	9.08	0.55	1.43	1.65	36	42
	40	276	2.76	19	5.8	2.60	9.84	0.59	1.39	1.60	35	41
	50	345	3.45	19	5.8	2.90	10.98	0.66	1.55	1.79	39	45
270°	20	138	1.38	16	4.9	2.90	10.98	0.66	1.45	1.68	37	43
	30	207	2.07	17	5.2	3.40	12.87	0.77	1.51	1.74	38	44
	40	276	2.76	18	5.5	4.00	15.14	0.91	1.58	1.83	40	46
	50	345	3.45	18	5.5	4.50	17.03	1.02	1.78	2.06	45	52
360°	20	138	1.38	15	4.6	3.50	13.25	0.79	1.50	1.73	38	44
	30	207	2.07	17	5.2	4.40	16.66	1.00	1.47	1.69	37	43
	40	276	2.76	17	5.2	4.90	18.55	1.11	1.63	1.88	41	48
	50	345	3.45	18	5.5	5.40	20.44	1.23	1.60	1.85	41	47

*Data represents test results in zero wind. Adjust for local conditions. Radius may be reduced with the nozzle retention screw.





FIXED NOZZLES

Fixed Pattern Nozzles

Application: Residential / Commercial



Providing matched precipitation for even water distribution.

Available in four distances plus eight fixed patterns, providing an array of system configurations. Color-coded for easy identification.

Models

FN8
8' (2,4 M) Female
Nozzle, Green

FN10
10' (3 M) Female
Nozzle, Blue

FN12
12' (3,7 M) Female
Nozzle, Brown

FN15
15' (4,6 M) Female
Nozzle, Black

P12
12' (3,7 M) Male
Nozzle, Brown

P15
15' (4,6 M) Male
Nozzle, Black

15CS / FN15CS
Center Strip





15ES / FN15ES
End Strip

15SS / FN15SS
Side Strip





15HL / FN15HL
High Low

Performance Data - Male Threaded Nozzles





P-12 12' (3,7 M) MALE THREADED NOZZLE (BROWN)

NOZZLE/ PATTERN	PRESSURE			RADIUS		FLOW RATE			PRECIP in/hr		PRECIP mm/hr	
	PSI	kPa	Bars	Ft.	M.	GPM	L/M	M ³ /H	■	▲	■	▲
 P12Q 90°	20	138	1.4	11	3.4	0.50	1.89	0.11	1.59	1.84	40	47
	25	172	1.7	12	3.7	0.70	2.65	0.16	1.87	2.16	47	55
	40	276	2.8	13	4.0	0.80	3.03	0.18	1.82	2.10	46	53
	50	345	3.4	14	4.3	0.90	3.41	0.20	1.77	2.04	45	52
 P12H 180°	20	138	1.4	11	3.4	0.90	3.41	0.20	1.43	1.65	36	42
	25	172	1.7	12	3.7	1.10	4.16	0.25	1.47	1.70	37	43
	40	276	2.8	13	4.0	1.40	5.30	0.32	1.59	1.84	40	47
	50	345	3.4	14	4.3	1.50	5.68	0.34	1.47	1.70	37	43
 P12TQ 270°	20	138	1.4	11	3.4	1.20	4.54	0.27	1.27	1.47	32	37
	25	172	1.7	12	3.7	1.40	5.30	0.32	1.25	1.44	32	37
	40	276	2.8	13	4.0	1.70	6.44	0.39	1.29	1.49	33	38
	50	345	3.4	14	4.3	2.00	7.57	0.45	1.31	1.51	33	38
 P12F 360°	20	138	1.4	11	3.4	1.60	6.06	0.36	1.27	1.47	32	37
	25	172	1.7	12	3.7	1.80	6.81	0.41	1.20	1.39	31	35
	40	276	2.8	13	4.0	2.10	7.95	0.48	1.20	1.38	30	35
	50	345	3.4	14	4.3	2.40	9.08	0.55	1.18	1.36	30	35

P-15 15' (4,6 M) MALE THREADED NOZZLE (BLACK)

NOZZLE/ PATTERN	PRESSURE			RADIUS		FLOW RATE			PRECIP in/hr		PRECIP mm/hr	
	PSI	kPa	Bars	Ft.	M.	GPM	L/M	M ³ /H	■	▲	■	▲
 P15Q 90°	20	138	1.4	11	3.4	0.50	1.89	0.11	1.59	1.84	40	47
	25	172	1.7	12	3.7	0.70	2.65	0.16	1.87	2.16	47	55
	40	276	2.8	13	4.0	0.80	3.03	0.18	1.82	2.10	46	53
	50	345	3.4	14	4.3	0.90	3.41	0.20	1.77	2.04	45	52
 P15H 180°	20	138	1.4	11	3.4	0.90	3.41	0.20	1.43	1.65	36	42
	25	172	1.7	12	3.7	1.10	4.16	0.25	1.47	1.70	37	43
	40	276	2.8	13	4.0	1.40	5.30	0.32	1.59	1.84	40	47
	50	345	3.4	14	4.3	1.50	5.68	0.34	1.47	1.70	37	43
 P15TQ 270°	20	138	1.4	11	3.4	1.20	4.54	0.27	1.27	1.47	32	37
	25	172	1.7	12	3.7	1.40	5.30	0.32	1.25	1.44	32	37
	40	276	2.8	13	4.0	1.70	6.44	0.39	1.29	1.49	33	38
	50	345	3.4	14	4.3	2.00	7.57	0.45	1.31	1.51	33	38
 P15F 360°	20	138	1.4	11	3.4	1.60	6.06	0.36	1.27	1.47	32	37
	25	172	1.7	12	3.7	1.80	6.81	0.41	1.20	1.39	31	35
	40	276	2.8	13	4.0	2.10	7.95	0.48	1.20	1.38	30	35
	50	345	3.4	14	4.3	2.40	9.08	0.55	1.18	1.36	30	35





Performance Data - Special Patterns, Female Threaded Nozzles

PATTERN	NOZZLE		PRESSURE			RADIUS		FLOW RATE	
	Male#	Female#	PSI	kPa	Bars	Feet	Meters	GPM	L/M
Center strip 	15CS	FN15CS	20	150	1,5	4' x 24'	1,2 x 7,3	0.8	3,0
			30	200	2,0	4' x 30'	1,2 x 9,1	1.0	3,8
End Strip 	15ES	FN15ES	20	150	1,5	4' x 12'	1,2 x 3,7	0.4	1,5
			30	200	2,0	4' x 15'	1,2 x 4,6	0.5	1,9
Side Strip 	15SS	FN15SS	20	150	1,5	4' x 28'	1,2 x 8,5	1.1	4,2
			30	200	2,0	5' x 32'	1,5 x 9,8	1.3	4,9
High Low 	15HL	FN15HL	20	150	1,5	H14' x L4' x 28'	4,3 x 1,2 x 8,5	2.5	9,5
			30	200	2,0	H15' x L5' x 32'	4,6 x 1,5 x 9,8	3.0	11,4





*Data represents test results in zero wind. Adjust for local conditions. Radius may be reduced with the nozzle retention screw.

Performance Data - Female Threaded Nozzles





FN-8 8' (2,4 M) FEMALE THREADED NOZZLE (GREEN)

NOZZLE/ PATTERN	PRESSURE			RADIUS		FLOW RATE			PRECIP in/hr		PRECIP mm/hr	
	PSI	kPa	Bars	Ft.	M.	GPM	L/M	M ³ /H	■	▲	■	▲
FN8Q 90° 	20	138	1.4	6	1.8	0.21	0.8	0.05	2.25	2.59	57	66
	25	172	1.7	7	2.1	0.24	0.9	0.05	1.89	2.18	48	55
	30	207	2.1	8	2.4	0.26	1.0	0.06	1.56	1.81	40	46
FN8H 180° 	20	138	1.4	6	1.8	0.42	1.6	0.10	2.25	2.59	57	66
	25	172	1.7	7	2.1	0.47	1.8	0.11	1.85	2.13	47	54
	40	276	2.8	8	2.4	0.52	2.0	0.12	1.56	1.81	40	46
FN8TQ 270° 	20	138	1.4	6	1.8	0.63	2.4	0.14	2.25	2.59	57	66
	25	172	1.7	7	2.1	0.71	2.7	0.16	1.86	2.15	47	54
	40	276	2.8	8	2.4	0.78	3.0	0.18	1.56	1.81	40	46
FN8F 360° 	20	138	1.4	6	1.8	0.86	3.3	0.20	2.30	2.66	58	67
	25	172	1.7	7	2.1	0.96	3.6	0.22	1.89	2.18	48	55
	40	276	2.8	8	2.4	1.05	4.0	0.24	1.58	1.82	40	46





FN-10 10' (3 M) FEMALE THREADED NOZZLE (BLUE)

NOZZLE/ PATTERN	PRESSURE			RADIUS		FLOW RATE			PRECIP in/hr		PRECIP mm/hr	
	PSI	kPa	Bars	Ft.	M.	GPM	L/M	M ³ /H	■	▲	■	▲
FN10Q 90° 	20	138	1.4	8	2.4	0.33	1.2	0.07	1.99	2.29	50	58
	25	172	1.7	9	2.7	0.36	1.4	0.08	1.71	1.98	43	50
	30	207	2.1	10	3.1	0.39	1.5	0.09	1.50	1.73	38	44
FN10H 180° 	20	138	1.4	8	2.4	0.65	2.5	0.15	1.96	2.26	50	57
	25	172	1.7	9	2.7	0.72	2.7	0.16	1.71	1.98	43	50
	30	207	2.1	10	3.1	0.79	3.0	0.18	1.52	1.76	39	45
FN10TQ 270° 	20	138	1.4	8	2.4	0.98	3.7	0.22	1.97	2.27	50	58
	25	172	1.7	9	2.7	1.08	4.1	0.25	1.71	1.98	43	50
	30	207	2.1	10	3.1	1.18	4.5	0.27	1.51	1.75	38	44
FN10F 360° 	20	138	1.4	8	2.4	1.03	3.9	0.23	1.55	1.79	39	45
	25	172	1.7	9	2.7	1.44	5.5	0.33	1.71	1.98	43	50
	30	207	2.1	10	3.1	1.58	6.0	0.36	1.52	1.76	39	45

FN-12 12' (3,7 M) FEMALE THREADED NOZZLE (BROWN)

NOZZLE/ PATTERN	PRESSURE			RADIUS		FLOW RATE			PRECIP in/hr		PRECIP mm/hr	
	PSI	kPa	Bars	Ft.	M.	GPM	L/M	M ³ /H	■	▲	■	▲
FN12Q 90° 	20	138	1.4	10	3.1	0.53	2.0	0.12	2.04	2.36	52	60
	25	172	1.7	11	3.4	0.60	2.3	0.14	1.91	2.20	48	56
	30	207	2.1	12	3.7	0.65	2.5	0.15	1.74	2.01	44	51
FN12H 180° 	20	138	1.4	10	3.1	1.05	4.0	0.24	2.02	2.33	51	59
	25	172	1.7	11	3.4	1.20	4.5	0.27	1.91	2.20	48	56
	30	207	2.1	12	3.7	1.30	4.9	0.30	1.74	2.01	44	51
FN12TQ 270° 	20	138	1.4	10	3.1	1.58	6.0	0.36	2.03	2.34	51	59
	25	172	1.7	11	3.4	1.80	6.8	0.41	1.91	2.20	48	56
	30	207	2.1	12	3.7	1.95	7.4	0.44	1.74	2.01	44	51
FN12F 360° 	20	138	1.4	10	3.1	2.10	7.9	0.48	2.02	2.33	51	59
	25	172	1.7	11	3.4	2.40	9.1	0.55	1.91	2.20	48	56
	30	207	2.1	12	3.7	2.60	9.8	0.59	1.74	2.01	44	51

FN-15 15' (4,6 M) FEMALE THREADED NOZZLE (BLACK)

NOZZLE/ PATTERN	PRESSURE			RADIUS		FLOW RATE			PRECIP in/hr		PRECIP mm/hr	
	PSI	kPa	Bars	Ft.	M.	GPM	L/M	M ³ /H	■	▲	■	▲
FN15Q 90° 	20	138	1.4	12	3.7	0.75	2.8	0.17	2.01	2.32	51	59
	25	172	1.7	14	4.3	0.82	3.1	0.19	1.61	1.86	41	47
	30	207	2.1	15	4.6	0.92	3.5	0.21	1.57	1.82	40	46
FN15H 180° 	20	138	1.4	12	3.7	1.50	5.7	0.34	2.01	2.32	51	59
	25	172	1.7	14	4.3	1.65	6.2	0.37	1.62	1.87	41	47
	30	207	2.1	15	4.6	1.85	7.0	0.42	1.58	1.83	40	46
FN15TQ 270° 	20	138	1.4	12	3.7	2.25	8.5	0.51	2.01	2.32	51	59
	25	172	1.7	14	4.3	2.48	9.4	0.56	1.62	1.88	41	48
	30	207	2.1	15	4.6	2.78	10.5	0.63	1.59	1.83	40	46
FN15F 360° 	20	138	1.4	12	3.7	3.00	11.4	0.68	2.01	2.32	51	59
	25	172	1.7	14	4.3	3.30	12.5	0.75	1.62	1.87	41	47
	30	207	2.1	15	4.6	3.70	14.0	0.84	1.58	1.83	40	46

*Data represents test results in zero wind. Adjust for local conditions. Radius may be reduced with the nozzle retention screw.





PC DRIPLINE SYSTEM

Application: Non-turf Areas

The K-Rain® Dripline System provides irrigation efficiency and trouble-free operation for non-turf areas.

Eliminates run-off and overspray common with conventional sprinklers.

Durable poly tubing is manufactured with high quality resins which offers stress-cracking resistance, burst strength and flexibility. The check valve feature prevents water from draining at lower elevations along the line and protects drip emitters from siphoning sediment, small particles and debris at the end of each irrigation cycle.

Features and Benefits

- **Install Above or Below Grade.**
- **Pressure-compensating Emitters** – Ensure uniform output across the entire length of run.
- **In-line Emitter Check Valves** – Prevents drainage from the dripline when water pressure drops below 2.5 PSI (0,17 bar), protecting against the siphoning of small sediment and soil particles into the drip emitter – ideal for sub-surface installation.
- **Available in Two Flow Rates and 2 spacing sizes** – Provides maximum design flexibility in a variety of applications.

Specifications

- Flow rates: .58 GPH (2,3 L/H) color code - orange, 1 GPH (3,8 L/H) color code - gray
- Operating pressure: 12 – 50 PSI (0,8 – 3,5 BAR)
- Check valve sealing pressure: 2.5 PSI (0,17 BAR)
- Check valve opening pressure: 4.3 PSI (0,3 BAR)
- Materials: Dow FINGERPRINT™ DFDA-7510 NT linear low-density polyethylene resin
- Dripline color: brown
- Size: 1/2" (.570" ID x .670" OD) (14,5 mm ID x 17 mm OD)
- Spacing: 12" or 18" (30,5 cm or 45,7 cm)
- Available in 100' coils (30 m)
- Minimum bending radius: 1' (0,3 m)
- Filter requirement: minimum of 150 mesh

Models

- KA1-118P -CV** .67" (17 mm) 1 GPH (3,8 LPH), 100' (30,5 m) CV drip line coil w/18" (0,45 m) spacing, .57" ID x .67" OD (14,5 mm ID x 17 mm OD), brown
- KA1-218P -CV** .67" (17 mm) 1 GPH (3,8 LPH), 250' (76,2 m) CV drip line coil w/18" (0,45 m) spacing, .57" ID x .67" OD (14,5 mm ID x 17 mm OD), brown
- KA1-518P -CV** .67" (17 mm) 1 GPH (3,8 LPH), 500' (152,4 m) CV drip line coil w/18" (0,45 m) spacing, .57" ID x .67" OD (14,5 mm ID x 17 mm OD), brown
- KA1-18P -CV** .67" (17 mm) 1 GPH (3,8 LPH), 1,000' (304,8 m) CV drip line coil w/18" (0,45 m) spacing, .57" ID x .67" OD (14,5 mm ID x 17 mm OD), brown
- KA5-112P -CV** .67" (17 mm) .58 GPH (2,2 LPH), 100' (30,5 m) CV drip line coil w/12" (0,45 m) spacing, .57" ID x .67" OD (14,5 mm ID x 17 mm OD), brown
- KA5-212P -CV** .67" (17 mm) .58 GPH (2,2 LPH), 250' (76,2 m) CV drip line coil w/12" (0,45 m) spacing, .57" ID x .67" OD (14,5 mm ID x 17 mm OD), brown
- KA5-512P -CV** .67" (17 mm) .58 GPH (2,2 LPH), 500' (152,4 m) CV drip line coil w/12" (0,45 m) spacing, .57" ID x .67" OD (14,5 mm ID x 17 mm OD), brown
- KA5-12P -CV** .67" (17 mm) .58 GPH (2,2 LPH), 1,000' (304,8 m) CV drip line coil w/12" (0,45 m) spacing, .57" ID x .67" OD (14,5 mm ID x 17 mm OD), brown
- K15-040** .67" (17 mm) barb coupling
- K15-041** .67" (17 mm) tee
- K15-042** .67" (17 mm) elbow
- K15-043** .67" (17 mm) barb x 1/2" (1,27 cm) NPT Tee
- K15-046** .67" (17 mm) barb x 1/2" (1,27 cm) NPT Adapter
- K18-028** 1/2" (1,27 cm) Air/Vacuum Relief Valve
- KP11-155** 3/4" (1,9 cm) plastic filter with 155 m stainless steel screen & flush cap



TREE BUBBLERS

Pressure Compensating Tree Bubblers

Application: Non-turf Areas

The K-Rain® pressure compensating bubblers are ideal for tree and large shrub watering.

Pressure compensation ensures consistent flow rates over lower pressure ranges.



Specifications

- Flow Rate:
 - TB-05: 0.5 GPM (0,114 m³/h; 1,9 l/m)
 - TB-10: 1.0 GPM (0,227 m³/h; 3,8 l/m)
 - TB-20: 2.0 GPM (0,454 m³/h; 7,6 l/m)
 - TB-ADJ: 1.36 – 5.9 GPM (0,31 – 1,34 m³/h; 5 – 22 l/m)
- Operating Pressure: 20 – 50 PSI (1,4 – 2,8 bar)
- Spacing: 1' – 3' (0,3 m – 0,9 m)
- Inlet: 1/2" (1,3 cm) Female Thread
- Umbrella Pattern

Models

- TB-025** 0.25 GPM (0,95 LPM) Bubbler
- TB-05** 0.5 GPM (1,9 LPM) Bubbler
- TB-10** 1.0 GPM (3,8 LPM) Bubbler
- TB-20** 2.0 GPM (7,6 LPM) Bubbler
- TB-ADJ** Adjustable Bubbler, Pressure Compensating

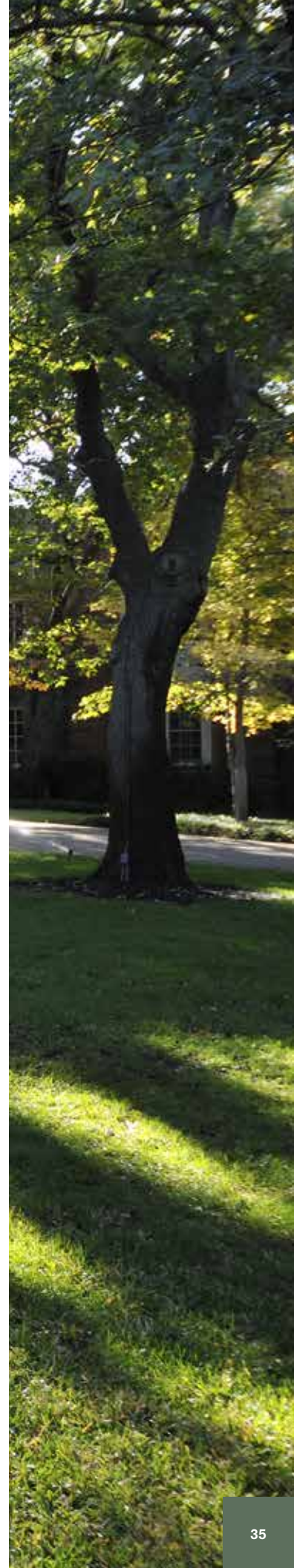

PROSERIES 100 VALVES

Application: Residential / Commercial / Dirty Water



These reliable valves offer a straight-through flow pattern, reducing the risk of failure due to trapped debris.

It has both an internal bleed and external bleed screw in addition to optional flow control. The inside diameter (ID) is 1" (2,5 cm) slip and glue or NPT/BSP.

Features and Benefits

- **Heavy Duty, Corrosion and UV Resistant PVC Construction** – Increases the life of the valve.
- **Tilt Diaphragm/Piston Assembly** – Allows for a straight flow path of water, increasing the flow rate while reducing friction loss.
- **Debris Tolerant Design** – Offers flexibility for use in potable or dirty water applications.
- **Manual External Bleed Screw** – Provides for manual operation in system start up.
- **Manual Internal Bleed Through Solenoid** – Permits manual operation without discharging water outside valve.
- **Flow Control with Removable Handle** – Delivers precise flow adjustment to the zone and allows you to remove the handle to prevent tampering (Except NFC).
- **Captured Plunger** – Remove the solenoid without losing the internal plunger.
- **Self Cleaning Screen** – Screen is in turbulent flow of water for self-cleaning action during operation.

Specifications

OPERATING SPECIFICATIONS

- Pressure Rating: 20 – 150 PSI (1,4 – 10,3 bar)
- Flow Range: .25 – 35 GPM (0,95 – 133 LPM)

PROSERIES 100 1" AND 3/4" VALVES

Flow Rate - GPM	5	10	15	20	30
PSI Loss	2.2	3.0	3.5	4.0	5.0

Pressure range: 20-150 psi (1,4 - 10,3 bar)

ELECTRICAL SPECIFICATIONS

- Solenoid: 24V AC 60 Hz
- Inrush Current: .43 Amps
- Holding Current: .25 Amps

DIMENSIONS

- Height: 4" (10,2 cm)
- Width: 3" (7,6 cm)
- Length: 5 1/4" (13,3 cm)

FLOW THROUGH

The unique tilted diaphragm creates a better flow path than traditional globe style electric valves by decreasing friction loss and increasing flow rate.



SELF-CLEANING SCREEN

The straight flow path allows debris to move through and the turbulent water flow cleans the diaphragm filter screen. This provides long life in applications using well or lake water.



CAPTURED PLUNGER SOLENOID

Easy removal when servicing without losing internal parts. Epoxy encapsulated solenoid design ensures longevity unlike the competition's overmolded solenoid.



MANUAL FLOW CONTROL

Precisely adjust flow to the zone. Removable handle prevents tampering.



Models

7001	1" (2,5 cm) Female Thread x Female Thread
7001-SL	1" (2,5 cm) Female Slip
7001-BSP	1" (2,5 cm) Female BSP Thread
7001-NFC	1" (2,5 cm) Female Thread
7001-SL-NFC	1" (2,5 cm) Female Slip without Flow Control
7001-BSP-NFC	1" (2,5 cm) Female BSP Thread without Flow Control
7001-MXB	1" (2,5 cm) Male Thread x 1" (2,5 cm) Male Barb
7001-MXM	1" (2,5 cm) Male Thread x 1" (2,5 cm) Male Thread
7001-BSP-MXM	1" (2,5 cm) Male BSP Thread x 1" (2,5 cm) Male Thread
7001-MXM-NFC	1" (2,5 cm) Male Thread x 1" (2,5 cm) Male Thread without Flow Control

7001-BSP-MXM-NFC	1" (2,5 cm) Male BSP Thread x 1" (2,5 cm) Male Thread without Flow Control
7001-MXB-NFC	1" (2,5 cm) Male Thread x 1" (2,5 cm) Male Barb without Flow Control
7075	3/4" (19 mm) Female Thread
7075-NFC	3/4" (19 mm) Female Thread without Flow Control
7075-SL	3/4" (19 mm) Female Slip
7075-SL-NFC	3/4" (19 mm) Female Slip without Flow Control
7075-BSP	3/4" (19 mm) Female BSP Thread
7075-BSP-NFC	3/4" (19 mm) Female BSP Thread without Flow Control

All valves equipped with 24VAC Solenoids.

Other options add to part number:

-9VDC 9 Volt DC Solenoid



PROSERIES 150 VALVE

Application: Residential / Commercial



The K-Rain® ProSeries 150 Valves offer the irrigation professional a wide array of features and benefits.

The 1", 1-1/2" and 2" (2,5 cm, 3,8 and 5 cm) models have a removable metering pin and external bleed screw promoting easy maintenance and manual operation.

The Jar-Top valve provides the professional contractor easy servicing access.

The 1-1/2" and 2" (3,8 and 5 cm) models feature a removable inlet cap to easily modify configuration from globe to angle.

Features and Benefits

ALL MODELS

- **Heavy Duty, Corrosion and UV Resistant PVC Construction** – Increases the life of the valve.
- **Manual External Bleed Screw** – Provides for manual operation in system start up.
- **Manual Internal Bleed through Solenoid** – Provides for manual operation without discharging water outside the valve.
- **Captured Plunger** – Allows for the solenoid to be removed without losing the internal plunger.
- **Flow Control** – Allows for precise flow adjustment.

1", 1-1/2" AND 2" MODELS

- **External Bleed Screw with Removable Metering Pin** – Allows for easy cleaning of the metering pin without disassembling the valve.

1-1/2" AND 2" MODELS

- **Removable Inlet Cap** – Allows for easy conversion from globe to angle-style valve.
- **Heavy Duty Santoprene® Diaphragm** – Unique design improves durability of diaphragm.

JAR-TOP MODELS

- **Threaded Jar-Top** – Allows for quick removal of the cap for easy servicing after installation.
- **Glass-Filled Nylon Screw Cap** – Increased durability.

Models

7101	1" (2,5 cm) Female Thread, NPT
7101-SL	1" (2,5 cm) Female Slip
7101-BSP	1" (2,5 cm) Female Thread, BSP
7101-BSP-FC	1" (2,5 cm) Female Thread, BSP with Flow Control
7101-FC	1" (2,5 cm) Female Thread, NPT with Flow Control
7101-SL-FC	1" (2,5 cm) Female Slip with Flow Control
7101-J	1" (2,5 cm) Female Thread Jar-Top, NPT
7101-J-SL	1" (2,5 cm) Female Slip Jar-Top
7101-J-BSP	1" (2,5 cm) Female Thread Jar-Top, BSP
7101-J-MXB	1" (2,5 cm) Male Thread x 1" (2,5 cm) Barb Jar-Top
7115	1 1/2" (3,8 cm) Female Thread
7115-BSP	1 1/2" (3,8 cm) Female Thread, BSP
7102	2" (5 cm) Female Thread
7102-BSP	2" (5 cm) Female Thread, BSP

Specifications

OPERATING; 1" (2,5 CM) MODELS

- Pressure Rating: 10 – 150 PSI (0,7 – 10,3 bar)
- Flow Range: .25 – 30 GPM (0,95 – 113,8 LPM)

7101 PROSERIES 150 1" (2,5 CM) VALVE

Flow Rate - GPM	5	10	15	20	30
PSI Loss	2.9	2.1	1.8	3.0	5.0

7101-FC PROSERIES 150 1" (2,5 CM) VALVE

Flow Rate - GPM	5	10	15	20	30
PSI Loss	6	4.1	4.1	3.1	6.0

PROSERIES 150 1" (2,5 CM) VALVE WITH JAR-TOP

Flow Rate - GPM	5	10	15	20	30
PSI Loss	3.3	3.9	2.9	3.2	6.1

Pressure range: 10-150 psi (0,7 a 10,3 bar)

OPERATING; 1-1/2" & 2" (3,8 & 5 CM) MODELS

- Pressure Rating: 20 – 150 PSI (1,4 – 10,3 bar)
- Flow Range: 20 – 120 GPM (75,7 – 454, 2 LPM)

PROSERIES 150 1-1/2" (3,8 CM) VALVE

Flow Rate - GPM	20	30	40	50	60	80
PSI Loss - Globe	3.0	2.6	2.3	2.9	4.1	5.5
PSI Loss - Angle	2.7	2.2	1.9	2.2	3.0	4.4

PROSERIES 150 2" (5 CM) VALVE

Flow Rate - GPM	20	30	40	50	60	80	100	120
PSI Loss - Globe	2.2	1.9	1.7	1.5	1.6	2.9	4.8	6.2
PSI Loss - Angle	1.9	1.9	1.7	1.5	1.5	2.1	3.2	4.6

Pressure range: 20-150 psi (1,4 a 10,3 bar)

ELECTRICAL SPECIFICATIONS

- Standard Solenoid: 24V AC 60 Hz
- Inrush Current: .43 Amps
- Holding Current: .25 Amps

DIMENSIONS

- 1" Models: Height: 5 1/4" (13,3 cm), Width: 3 1/8" (7,95 cm), Length: 5" (12,7 cm)
- 1" Flow Control Models: Height: 5 7/8" (14,9 cm), Width: 3 1/8" (7,95 cm), Length: 5" (12,7 cm)
- 1" Jar-Top Models: Height: 5 1/4" (13,3 cm), Width: 3" (7,6 cm), Length: 4 3/8" (11,1 cm)
- 2" Models: Height: 8-7/8" (22,6 cm), Width: 4-7/8" (12,4 cm), Length: 6-1/3" (16,1 cm)
- 1-1/2" Models: Height: 8" (20,3 cm), Width: 4-1/4" (10,8 cm), Length: 5-1/2" (14 cm)

Manual External Bleed Screw

The 1", 1 1/2" and 2" (2,5, 3,8 and 5 cm) models feature a removable external bleed screw and metering pin to simplify cleaning and maintenance. With the External Bleed Screw, manual operation during start up is easy.

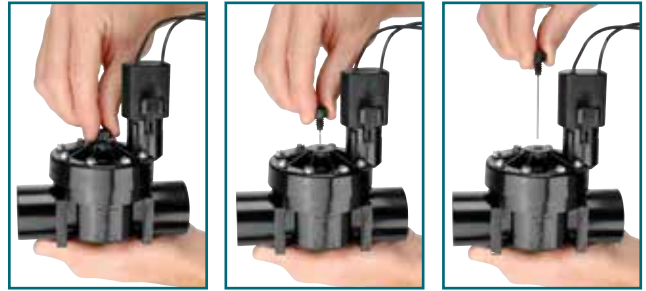

No Tools Required

The K-Rain Jar-Top valve allows for quick and easy servicing after installation.



System Flexibility

Removable inlet cap allows for easy conversion from globe to angle-style valve.



PROSERIES 200 VALVES

Application: Residential / Commercial



A durable, feature-packed electric valve designed to handle up to 200 PSI (13,8 bar) operating pressure.

The glass filled nylon construction and reinforced rubber diaphragm ensure reliable performance.

The 200 series valve has a working pressure range from 6 PSI (0,41 bar) minimum to 200 PSI (13,8 bar) maximum and recommended flow range from 5 to 150 GPM (19 to 568 LPM).

Features and Benefits

- **Durable Glass-filled Nylon Construction and Reinforced Rubber Diaphragm** – Ensures long life and reliable performance.
- **Flow Control** – To adjust water flow as needed (except 7201-J).
- **Large Internal Openings and Self-cleaning Diaphragm During Every Cycle** – Reduces maintenance time.
- **Water Flow Indicator** – Ensures proper installation every time.
- **Electric or Manual Operation**

Models

- 7201** 1" (2,5 cm) Female Thread
7215 1 1/2" (3,8 cm) Female Thread
7202 2" (5 cm) Female Thread

Other options add to part number:

- BSP** Female BSP Inlet and Outlet

Specifications

OPERATING SPECIFICATIONS

- Pressure Rating: 6 - 200 PSI (0,41 – 13,79 LPM)
- Flow Range: 5 - 150 GPM (0,41 – 13,79 LPM)

7201 1" (2,5 CM) VALVE

Flow Rate - GPM	5	10	15	20	25	30
PSI Loss	.4	1.16	2.45	4.65	7.25	9.70

7215 1.5" (3,8 CM) VALVE

Flow Rate - GPM	20	25	30	40	50	60	80	100
PSI Loss	2.73	3.04	2.90	2.90	3.41	4.24	7.61	12.9

7202 2" (5 CM) VALVE

Flow Rate - GPM	20	25	30	40	50	60	80	100	120	150
PSI Loss	2.9	2.54	2.17	2.17	2.75	3.4	5.5	7.83	11.66	20.0

Pressure range: 6-200 psi (0,41 – 13,8 bar)

ELECTRICAL SPECIFICATIONS

- Standard solenoid: 24V AC 60 Hz
- Inrush current: .43 amp
- Holding current: .25 amp

DIMENSIONS

- 1" Models: Height: 5-1/4" (13,3 cm), Width: 3-1/8" (7,9 cm), Length: 5-1/8" (13,0 cm)
- 1" Jar-Top Models: Height: 5-3/4" (14,6 cm) Width: 3-1/8" (8 cm), Length: 4-3/4" (12,0 cm)
- 1-1/2" Models: Height: 6-3/4" (17,2 cm), Width: 4-1/4" (10,8 cm), Length: 6-1/4" (15,9 cm)
- 2" Models: Height: 7" (17,8 cm), Width: 4-1/4" (10,8 cm), Length: 7-1/4" (18,4 cm)

PRO LC

IRRIGATION CONTROLLER

Application: Residential / Commercial



The Pro LC offers a new perspective on affordable, conventional controllers with many of the features of the reliable and robust Pro Ex 2.0 controller (see page 45).

Available in fixed 4, 8 or 12 stations and as indoor or outdoor models, these compact controllers offer an array of user-friendly features including easy to follow programming; a full program screen display listing watering days, number of start times, number of stations and special programming; large LCD display; rain/freeze sensor compatibility; seasonal adjust for water conservation; a buried valve locator for easy maintenance and more.

Specifications

OPERATING SPECIFICATIONS

- Station Run Times:
1 minute to 6 hours for all stations
- Number of Programs: 3
- Number of Automatic Start Times:
4 per program
- Program Watering Schedules:
Odd (odd calendar days),
Even (even calendar days),
Custom (day of the week)

ELECTRICAL SPECIFICATIONS

- Power Input:
110V AC \pm 10% 60Hz,
240V AC \pm 10% 50Hz
- Power Output: 24V AC 1.0Amp
- Power Backup: Lithium coin-cell battery maintains time and date during primary power outages.
- Multi-Valve Operation: Up to 4
24V AC, 7VA solenoid valves.

DIMENSIONS

- Height: 7" (17,8 cm)
- Width: 7" (17,8 cm)
- Depth: 3.5" (8,9 cm)

Models

OUTDOOR MODELS

3104	4 station, 110V AC internal transformer
3104-220	4 station, 220V AC internal transformer
3108	8 station, 110V AC internal transformer
3108-220	8 station, 220V AC internal transformer
3112	12 station, 110V AC internal transformer
3112-220	12 station, 220V AC internal transformer

INDOOR MODELS

3104ID	4 station, 110V AC plug pack transformer
3104ID-220	4 station, 220V AC plug pack transformer
3108ID	8 station, 110V AC plug pack transformer
3108ID-220	8 station, 220V AC plug pack transformer
3112ID	12 station, 110V AC plug pack transformer
3112ID-220	12 station, 220V AC plug pack transformer





PRO EX 2.0 WiFi

MODULAR IRRIGATION CONTROLLER KIT

Application: Residential / Commercial



The Pro EX 2.0 WiFi Enabled Controller offers proven power and functionality with the convenience of world-wide control through your smartphone, tablet or web browser!

Easily and securely sync with homeowners' or business' WiFi, manage multiple accounts and increase your productivity tenfold! You will appreciate the easy programming and installation too!

Models

- 3202ID -WIFI-KIT** Pro EX 2.0 WiFi enabled indoor base unit with 4 station expansion module, WiFi hub, RF module, short range antenna, 110V AC plug pack transformer. Free iOS/android apps.
- 3202ID-220 -WIFI-KIT** Pro EX 2.0 WiFi enabled indoor base unit with 4 station expansion module, WiFi hub, RF module, short range antenna, 220V AC plug pack transformer. Free iOS/android apps.
- 3202 -WIFI-KIT** Pro EX 2.0 WiFi enabled outdoor base unit with 4 station expansion module, WiFi hub, RF module short range antenna. Free iOS/android apps.
- 3202-P -WIFI-KIT** Pro EX 2.0 WiFi enabled outdoor base unit with 4 station expansion module, WiFi hub, RF module, short range antenna, with pigtail. Free iOS/android apps.
- 3202-220 -WIFI-KIT** Pro EX 2.0 WiFi enabled outdoor base unit with 4 station expansion module, WiFi hub, RF module, short range antenna, 220V AC plug pack transformer. Free iOS/android apps.
- 3205** Pro EX 2.0, 4 station expansion module

FLOW SENSOR ASSEMBLIES

- FS735-10** 1" Complete Assembly
- FS228-15** 1-1/2" Complete Assembly
- FS228-20** 2" Complete Assembly
- FS228-30** 3" Complete Assembly
- FS228-40** 4" Complete Assembly



Specifications

OPERATING SPECIFICATIONS

- Station Run Times: 1 second to 6 hours for all stations
- Number of Programs: 3
- Number of Automatic Start Times: 4 per program
- Program Watering Schedules: Custom (day of the week), Interval (1-31 days), Odd (odd calendar days), Even (even calendar days)

ELECTRICAL SPECIFICATIONS

- Power Input: 110VAC ± 10% 60Hz, 240V AC ± 10% 50Hz
- Power Output: 24V AC 1.25 Amp
- Power Backup: Lithium coin-cell battery maintains time and date during primary power outages, 4 AAA batteries allow for remote programming and LCD viewing.
- Multi-Valve Operation: Up to three 24V AC, 7 VA solenoid valves

DIMENSIONS

- Height: 7 3/4" (19,6 cm)
- Width: 10" (25,4 cm)
- Depth: 5" (12,7 cm)

ProEx 2.0 WiFi Features and Benefits

- **Wifi enabled** – Syncs with wifi to allow functionality through a smartphone, tablet or web browser. Weather IQ with set-able limits. Remote access and alerts. Optional proprietary wifi booster.
- **Patented Full Program Display** – One screen shows watering days, number of start times, number of stations and special programming.
- **Flow Sensor Ready** – Connects directly. Has high/low flow abort settings and provides flow data capture.
- **Wireless Module Connector** – Allows for optional installation of wireless communication.
- **Diagnostic Circuit Breaker** – Identifies and isolates stations with valve or wiring problems (shorts, faults, valve location) while remaining program continues.
- **Advanced Diagnostic** – Visual and/or audible alerts when programming errors or other conditions have been detected and are preventing operation.
- **Station Delay/Overlap Programming** – Permits additional time between stations or dual operation for issues like well recovery, slow closing valves and water hammer.
- **Wireless Plug and Play RF Range of Add-in Accessories** – Hand held remote, wifi, wireless rain sensor, flow sensor.
- **Hot-Swappable 4 Station Modules** – Simple controller upgrades from 4 to 16 stations while controller is in operation.
- **Large Backlit LCD Screen** – Best in class visualization for all installations.
- **AM/PM or 24 Hour Clock Settings** – Allows user to choose the time format desired.
- **Flexible Operation** – Manual or remote operation.
- **System Test** – Allows a full system check for valve operation.
- **Manual Start** – Allows manual program operation at the push of a button.
- **Wire Management System** – Vertical station terminal strips allows full use of cabinet.
- **Permanent Memory** – Non-volatile memory saves program during power outages.
- **Locate Feature** – Aids in locating buried valves in field.
- **Sensor Bypass Switch** – Global override of active sensor for all stations.
- **Master Valve/Pump Start Ready** – Programming for individual station(s) operation as needed.
- **Valve Test Terminal (VT)** – Quick and easy matching of field wires with station during installation.
- **Dedicated Sensor Terminals** – Enables direct sensor installation for maximum watering control.
- **Default Programming** – Allows program to be saved and recalled without having to reprogram.
- **Permanent Day Off** – Set any day of the week, regardless of programming, as a non-watering day.
- **Seasonal Adjust** – Quick, easy global adjustment of watering times from 10-200% conserves water.





PRO EX 2.0

MODULAR IRRIGATION CONTROLLER

Application: Residential / Commercial

User-friendly programming and responsive touch pad takes Pro EX 2.0 to a whole new level for irrigation controllers.

Programming is simple with the largest backlit display on the market. Flexibility with easy expansion from 4 to 16 stations. Optional remote capability delivers the irrigation control right to your hand.



Models

- | | |
|-------------------|---|
| 3202 | Pro EX 2.0 base unit with 4 station expansion module, 115 VAC internal transformer |
| 3202ID | Pro EX 2.0 indoor base unit, 4 station expansion module, 110V AC plug pack transformer |
| 3202-P | Pro EX 2.0, modular controller, with pigtail, 115 VAC internal transformer |
| 3202-220 | Pro EX 2.0, modular controller, 220 VAC internal transformer |
| 3202ID-220 | Pro EX 2.0 indoor base unit, 4 station expansion module, 220V AC plug pack transformer |
| 3203 | Pro EX 2.0 handheld remote w/batteries |
| 3203-KIT | Handheld remote w/batteries, RF module with short distance antenna, long range antenna, coaxial cable |
| 3204 | Pro EX 2.0, 4 station expansion module |
| 3206 | RF module w/short distance antenna |
| 3207 | Extended range antenna kit |
| 3209 | WiFi Hub for Pro Ex 2.0 Controller |

Specifications

OPERATING SPECIFICATIONS

- Station Run Times: 1 second to 6 hours for all stations
- Number of Programs: 3
- Number of Automatic Start Times: 4 per program
- Program Watering Schedules:
Custom (day of the week), Interval (1-31 days),
Odd (odd calendar days), Even (even calendar days)

ELECTRICAL SPECIFICATIONS

- Power Input: 110V AC ± 10% 60Hz, 240V AC ± 10% 50Hz
- Power Output: 24V AC 1.25Amp
- Power Backup: Lithium coin-cell battery maintains time and date during primary power outages while the 4 AAA batteries allow for remote programming and LCD viewing.
- Multi-Valve Operation: Up to 3 24V AC, 7VA solenoid valves.

DIMENSIONS

- Height: 7 3/4" (19,6 cm)
- Width: 10" (25,4 cm)
- Depth: 5" (12,7 cm)

ProEx 2.0 Features and Benefits

- **Patented Full Program Display** – One screen shows watering days, number of start times, number of stations and special programming.
- **Flow Sensor Ready** – Connects directly. Has high/low flow abort settings and provides flow data capture.
- **Wireless Module Connector** – Allows for optional installation of wireless communication.
- **Diagnostic Circuit Breaker** – Identifies and isolates stations with valve or wiring problems (shorts, faults, valve location) while remaining program continues.
- **Advanced Diagnostic** – Visual and/or audible alerts when programming errors or other conditions have been detected and are preventing operation.
- **Station Delay/Overlap Programming** – Permits additional time between stations or dual operation for issues like well recovery, slow closing valves and water hammer.
- **Wireless Plug and Play RF Range of Add-in Accessories** – Hand held remote, wifi, wireless rain sensor, flow sensor.
- **Hot-Swappable 4 Station Modules** – Simple controller upgrades from 4 to 16 stations while controller is in operation.
- **Large Backlit LCD Screen** – Best in class visualization for all installations.
- **AM/PM or 24 Hour Clock Settings** – Allows user to choose the time format desired.
- **Flexible Operation** – Manual or remote operation.
- **System Test** – Allows a full system check for valve operation.
- **Manual Start** – Allows manual program operation at the push of a button.
- **Wire Management System** – Vertical station terminal strips allows full use of cabinet.
- **Permanent Memory** – Non-volatile memory saves program during power outages.
- **Locate Feature** – Aids in locating buried valves in field.
- **Sensor Bypass Switch** – Global override of active sensor for all stations.
- **Master Valve/Pump Start Ready** – Programming for individual station(s) operation as needed.
- **Valve Test Terminal (VT)** – Quick and easy matching of field wires with station during installation.
- **Dedicated Sensor Terminals** – Enables direct sensor installation for maximum watering control.
- **Default Programming** – Allows program to be saved and recalled without having to reprogram.
- **Permanent Day Off** – Set any day of the week, regardless of programming, as a non-watering day.
- **Seasonal Adjust** – Quick, easy global adjustment of watering times from 10-200% conserves water.

Accessories

Remote and WiFi capability expands irrigation control right in your hand!

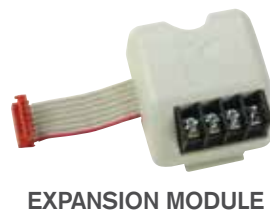



BL-24

BLUETOOTH SMART IRRIGATION CONTROLLER

Application: Residential / Commercial

The K-Rain® BL-24 bluetooth operated controller now has an updated application uniting users with new time-saving and productivity-enhancing benefits.



Features and Benefits

- Change controller settings via smartphone, tablet or web browser from up to 35' (10 m) away.
- Manage up to 400 controllers from one app. – one easy app does it all.
- Geo-location feature – shows every site, every controller, every program.
- Updates you and your field team any time a setting is changed.
- Full virtual back up to the cloud for easy future restoration
- 4, 6, 9 and 12 station models.
- LED indicator for monitoring operation.
- Indoor wall mounting with plug pack transformer.
- Master valve connection.
- 8 independent programs with 8 start times.
- Rain sensor connection.



Specifications

OPERATING SPECIFICATIONS

- AC Power
- Input: 110V 60 Hz
- Output: 24V 60 Hz
- Maximum load 0.75 AMPS on the output (18 VA)
- Ability to power a 24V Solenoid coil plus master valve (or pump start relay)
- Surge protection to 4kV on all inputs/outputs

4, 6 STATION MODELS:

- Height: 5 3/4" (14,5 cm)
- Width: 4 1/4" (11 cm)
- Depth: 1 1/2" (3,6 cm)

9, 12 STATION MODELS:

- Height: 5 3/4" (14,5 cm)
- Width: 6 1/4" (16 cm)
- Depth: 1 1/2" (3,6 cm)

Models

- BL-24-4 4 Station Bluetooth Controller
- BL-24-6 6 Station Bluetooth Controller
- BL-24-9 9 Station Bluetooth Controller
- BL-24-12 12 Station Bluetooth Controller

Scan QR Code to download the FREE K-Rain® BL-KR App.



GOOGLE PLAY
Android App

iTunes Apple
Device App



BL-KR

BATTERY POWERED CONTROLLER

Application: Residential

Programming control in the palm of your hand.

With 100% waterproof and rugged construction, the BL-KR is ideal for isolated sites and power-restricted areas. No more crawling around the valve box to program or troubleshoot a battery-powered timer. Programming is easy with a smartphone or tablet through direct Bluetooth communication up to 35' (10 m) away from the valve box. Add multiple controllers (up to 400 timers) and program simply and quickly from 1 free application.



Specifications

OPERATING SPECIFICATIONS

- 1, 2, 4, 6 stations
- Master valve connection (Except for BL-KR1 single station)
- 3 programs, 8 start times
- Rain/freeze sensor connection
- Bluetooth range; 35' (10m)

ELECTRICAL SPECIFICATIONS

- Works with 9V DC latching solenoids and a master valve equipped with a 9V DC latching solenoid
- Maximum distance between the timer and solenoid is 98' (30 m) with 18 AWG (.05" or 1,55 mm²)

DIMENSIONS

- Height: 2 1/8" (5,5 cm)
- Width: 5 1/2" (14 cm)
- Depth: 3 1/2" (9 cm)

Models

BL-KR1	1 Station
BL-KR2	2 Station
BL-KR4	4 Station
BL-KR6	6 Station

Features and Benefits

BL-KR BATTERY POWERED CONTROLLER TIMER

- Change controller settings via smartphone, tablet or web browser
- Manage up to 400 controllers from one easy app that does it all.
- Geo-location feature – shows every site, every controller, every program.
- Updates you and your field team any time a setting is changed.
- Alerts you when a battery replacement is required.
- IP68 certified fully waterproof enclosure installs right in the valve box.
- 1, 2, 4 and 6 station models
- Molded out of UV resistant, high impact ABS resin.
- Ideal for isolated/remote valve boxes where running power is expensive or difficult.
- Standalone – works with a 9V DC alkaline battery type.
- Full virtual back up – back up program information and preferences to the cloud for easy future restoration
- Rain/freeze sensor ready.

FREE SMARTPHONE/TABLET APPLICATION

- Transforms iOS or Android smartphone or tablet into a remote control to fully program your BL-KR controller(s) using Bluetooth Smart technology.
- Manually start, stop, or suspend your controller(s) from up to 35' away.
- Fully configure watering schedules and zones.
- Detect battery levels/connection status.
- Add a passcode lock to each controller for added security.
- Add multiple BL-KR controllers (up to 400) and program/control them using 1 app on your smartphone or tablet.





RPS™ 46

MINI IRRIGATION CONTROLLER

Application: Residential



The RPS™ 46 Mini Irrigation Controller, designed for residential applications, has four individual programs to allow for efficient watering on separate programs.

A key feature of this unit is the water budgeting feature which allows easy adjustment of watering schedules as the seasons change.

Features and Benefits

- **4 & 6 Station Models** – Perfect for residential lawns.
- **4 Fully Independent Programs** – Allowing up to 4 starts per program. Maximum 16 starts per day.
- **Indoor Models with External Transformer and Plug.**
- **Seasonal Adjustment** – Allows for quick adjustment of watering durations in 25% increments, from 25% to 150%.
- **Rain Sensor Ready** – Accepts rain sensor, controlled by bypass switch.
- **Flexible Manual Operation** – Run a program, run a station or test system.
- **Battery Back-Up** – Saves program during power outages.

Models

3504	4 Station, 110V Plug Pack Transformer
3504-220	4 Station, 220V Plug Pack Transformer
3506	6 Station, 110V Plug Pack Transformer
3506-220	6 Station, 220V Plug Pack Transformer

How to Specify

Model Number: **3506**

Description: **-220**

Specifications

OPERATING SPECIFICATIONS

- Station Run Times: 1 min. to 12 hrs. 59 min.
- Number of Programs: 4
- Number of Automatic Start Times: 4 per program
- Program Watering Schedules: 7 day calendar with individual day selection, or 1 to 15 day interval, or 365 day calendar for ODD/EVEN day watering.
- Rain Sensor Ready: Inhibits automatic watering when wet conditions are detected by a suitable rain sensor.
- Master Valve/pump start terminal.
- Automatic, semi-automatic and single station manual operation.

ELECTRICAL SPECIFICATIONS

- Power Input: 110V AC ± 10% 60Hz, 240V AC ± 10% 50Hz
- Power Output: 24V AC, 0.85 AMP
- To Solenoid Valve: 24V AC, 0.5 AMPS max.
- Total output load must not be exceeded by the valves and pump start requirements.
- Overload protection: Standard 20mm 1.0 AMP fuse
- Power Failure: 9 Volt standard alkaline battery maintains clock and program up to 2 weeks.
- Wiring: The output circuits should be installed and protected in accordance with wiring rules.

DIMENSIONS

- Height: 5 3/4" (14,5 cm)
- Width: 4 1/2" (11,43 cm)
- Depth: 1 3/4" (4,3 cm)

RPS™ 624

OUTDOOR IRRIGATION CONTROLLER

Application: Residential / Commercial



Features and Benefits

- 12, 18 and 24 Station Models Available.
- 6 Fully Independent Programs – Up to 4 separate start times per program. Max. 24 starts per day.
- Permanent Memory – Saves programs during power outages.
- 7 Day Watering Cycle – Individual day selection, odd/even date selection or interval watering.
- Rain Sensor Ready – Allows programming of individual station(s) operation to be controlled by sensor.
- Rain Off – Suspends watering during winter while retaining the time and programmed information.
- Flexible Manual Operation – Choose from automatic, semi-automatic and single station manual.
- System Test Feature.
- Water Conservative – Quick adjustment of watering durations in 10% increments, OFF to 200%.
- Master Valve/Pump Start.
- Second Programmable Pump – Available for dual water supply, fertigation or filtration control.
- Large Blue and White Backlit LCD – Easy to read, with “No AC” indicator on LCD when power is out.
- Current sensing – On individual stations and faulty station skip feature.
- Low Energy Micro-processor – Ensures long battery life.
- Outdoor Case – Lockable and waterproof.
- Audio Feedback – On key press and alarm.

A truly versatile controller.

RPS™ 624 offers the latest in micro-processor technology and exclusive low energy, high-output toroidal transformer.

Advanced features include current sensing and station skip with fault indication, and a real time clock maintains time in power outages.

Specifications

OPERATING SPECIFICATIONS

- Station Run Times: 1 min. to 12 hours 59 min.
- Number of Programs: 6
- Number of Automatic Start Times: 4 per program

ELECTRICAL SPECIFICATIONS

- Electrical Power Supply: 110V AC/220V AC delivering a 24 V AC through a 30 VA (1.25 AMP) rated Toroidal transformer
- Electrical Outputs: 24V AC, .75 AMP
24V AC, .25 AMP

DIMENSIONS

- Height: 9" (22,86 cm)
- Width: 9 1/4" (23,5 cm)
- Depth: 3 1/2" (8,9 cm)

Models

3912	12 station 110V internal transformer
3912-220	12 station 220V internal transformer
3918	18 station 110V internal transformer
3918-220	18 station 220V internal transformer
3924	24 station 110V internal transformer
3924-220	24 station 220V internal transformer





TC-KR

BATTERY POWERED TAP CONTROLLER

Application: Residential / Commercial

Easily add irrigation or misting to small lawn or garden areas, terraces and potted plants using your hose faucet.

Simple to use Bluetooth app controls your irrigation needs through your smartphone or tablet. Nurture beautiful lawn areas and flower beds with either the misting or irrigation mode of the controller.

The K-Rain® TC-KR battery powered tap controller is also perfect for filling your pool!



Specifications

OPERATING SPECIFICATIONS

- Inlet: 3/4" (1,9 cm) standard hose thread
- Outlet: 3/4" (1,9 cm) standard hose thread
- Recommended pressure: 7.25 – 87 PSI (0,5 – 6 bar)
- Recommended flow: 0.5 GPH – 10 GPM (1,9 LPH – 37,9 LPM)
- 9 volt battery required

OPERATING TEMPERATURE:

- Up to 122° F / 50° C
- Must protect against freezing temperatures

PROGRAMMING SPECIFICATIONS

Irrigation Mode:

- Up to 8 start times per day
- Run times from 1 minute to 12 hours
- Cycles: Days of the week, Odd/Odd31/ Even days, every other 1 to 31 days
- Rain delays up to 15 days or permanent
- Manual Start/stop

Misting Mode:

- Run times from 5 seconds to 24 hours
- Intervals between run times: 30 seconds to 31 days
- Up to 8 start times per day
- Cycles: days of the week

DIMENSIONS:

- Height: 5 3/4" (14,5 cm)
- Width: 4 1/2 " (11,4 cm)
- Depth: 2 1/2" (6,1 cm)

Features and Benefits

- Easy programming with free Bluetooth App.
- Smartphone or tablet control.
- No more climbing around hedges and landscaped areas to access the hose faucet.
- Conveniently replace pool water lost to evaporation from your smartphone or tablet.

Models

- TC-KR Battery Powered Tap Controller
- TC-KR-BSP Battery Powered Tap Controller w/BSP Thread

Scan QR Code to download the FREE K-Rain® BL App.



GOOGLE PLAY
Android App

iTunes Apple
Device App



RAIN SENSOR

Application: Residential

The Rain/Freeze and Rain Sensors will turn your irrigation controller into an expert water manager by efficiently suspending watering during rain and/or freeze periods.

After a set amount of rain has fallen and/or freezing temperatures exist (for models with freeze sensor), the sensor will trigger the controller to suspend watering.

Unlike other Rain Sensors on the market, the K-Rain® wireless rain-freeze sensor (model 3208-WRFS) can be paired with multiple K-Rain Pro EX 2.0 Wifi enabled controllers within range, providing an additional value for the end user. The wired rain sensors work with closed circuit timers.



Features and Benefits

- Weather resistant. Engineered with impact modified, UV resistant polymer for outdoor exposure.
- Maintenance free. No batteries to replace.
- 2 in 1 mounting. Provides flexible installation with standard flat and gutter mounting.
- Models 3208-WRFS and 3208-HRFS include a freeze sensor that prevents the irrigation system from starting when temperatures drop to 37°F (3°C) or below.
- Quick Installation. The Wireless Rain-Freeze Sensor 3208-WRFS provides the advantage of extremely quick installation and eliminates unsightly wires.

Models

- | | |
|----------------------|---|
| 3208-HRS | Hardwired Rain Sensor |
| 3208-HRFS | Hardwired Rain-Freeze Sensor |
| 3208-WRFS | Wireless Rain-Freeze Sensor for WiFi enabled Pro EX 2.0 |
| 3208-WRFS-KIT | Wireless Rain-Freeze Sensor and RF Module for WiFi enabled Pro EX 2.0 |



PUMP START RELAY

Application: Industrial

The rain-tight, secure, rustproof enclosure provides a safe and secure housing built to last.

The Pump Start Relay enclosure is constructed with a corrosion resistant, UV resistant, shockproof material.

Models

- | | | |
|-------------|---|---|
| 1510 | Coil Specifications
120V AC, 60 Hz
Inrush: 35 VA
Sealed: 7.0 VA
Resistance ($\pm 10\%$):
250 OHMS

Mini Coil
24V AC, 50/60 Hz
Inrush: 52 mA | Double Pole, Single Throw
Inductive: 20 AMP
Resistive: 30 AMP
Input: 120V AC - up to 2 H.P.
UL Rated

Sealed: 1.2 VA
Resistance ($\pm 10\%$): 155 OHMS |
| 1520 | Coil Specifications
240V AC, 60 Hz
Inrush: 35 VA
Sealed: 7.0 VA
Resistance ($\pm 10\%$):
1000 OHMS

Mini Coil
24V AC, 50/60 Hz
Inrush: 52 mA | Double Pole, Single Throw
Inductive: 20 AMP
Resistive: 30 AMP
Input: 240V AC - up to 3 H.P.
UL Rated

Sealed: 1.2 VA
Resistance ($\pm 10\%$): 155 OHMS |
| 1521 | Coil Specifications
120V AC, 60 Hz
Inrush: 42 VA
Sealed: 8.5 VA, 3.6 Watts
Resistance ($\pm 10\%$):
210 OHMS | Double Pole, Single Throw
Inductive: 20 AMP
Resistive: 30 AMP
Input: 120V AC - up to 3 H.P.
240V AC - up to 3 H.P. |
| 1522 | Coil Specifications
24V AC, 60 Hz
Inrush: 35 VA
Sealed: 7 VA, 3 Watts
Resistance ($\pm 10\%$):
11 OHMS | Double Pole, Single Throw
Inductive: 20 AMP
Resistive: 30 AMP
Input: 120V AC - up to 3 H.P.
240V AC - up to 3 H.P. |
| 1551 | Coil Specifications
120V AC, 60 Hz
Inrush: 77 VA
Sealed: 10 VA, 4 Watts
Resistance ($\pm 10\%$):
89.5 OHMS | Double Pole, Single Throw
Inductive: 40 AMP
Resistive: 50 AMP
Input: 120V AC - up to 3 H.P.
240V AC - up to 5 H.P. |
| 1552 | Coil Specifications
24V AC, 60 Hz
Inrush: 60 VA
Sealed: 7 VA, 2.3 Watts
Resistance ($\pm 10\%$):
5.61 OHMS | Double Pole, Single Throw
Inductive: 40 AMP
Resistive: 50 AMP
Input: 120V AC - up to 3 H.P.
240V AC - up to 5 H.P. |
| 1553 | Coil Specifications
24V AC, 60 Hz
Inrush: 60 VA
Sealed: 7 VA, 2.7 Watts
Resistance ($\pm 10\%$):
5.61 OHMS | THREE PHASE OPERATION
Triple Pole, Single Throw
Inductive: 40 AMP
Resistive: 50 AMP
Input: 120V AC - up to 3 H.P.
240V AC - up to 10 H.P. |



SINGLE STATION CONTROLLER

Application: Industrial



The K-Rain® Single Station Controllers have safe, rain-tight enclosures.

2100 models offer less hassle with a 24 hour programmable time dial with multiple start times and a wide variety of timing periods, including a “Skip-A-Day” 14 day program.

The 2200 models are perfect for nursery and other mist applications with a 10 minute programmable dial, a wide variety of timing periods and multiple start times.

The 2500 models are prewired for easy connection of a rainswitch, allowing for manual override of rainswitch from controller face.

Models

2100 SINGLE STATION CONTROLLERS

2110	Voltage Input: 110V AC, 60 Hz Output: 110V AC, 60 Hz	Rating Single Pole, Single Throw Relay Rated for up to 1 H.P.
2112	Voltage Input: 110V AC, 60 Hz Output: 110V AC, 60 Hz	Rating Double Pole, Single Throw Relay Rated for up to 2 H.P.
2114	Voltage Input: 110V AC, 60 Hz Output: 24V AC, 30 VA	Rating Built-In Transformer
2120	Voltage Input: 220V AC, 60 Hz Output: 220V AC, 60 Hz	Rating Double Pole, Single Throw Relay Rated for up to 2 H.P.
2124	Voltage Input: 220V AC, 60 Hz Output: 24V AC, 20 VA	Rating Built-In Transformer

2200 SHORT DURATION SINGLE STATION CONTROLLERS

2210	Voltage Input: 110V AC, 60 Hz Output: 110V AC, 60 Hz	Rating Relay Rated for up to 1 H.P.
2214	Voltage Input: 110V AC, 60 Hz Output: 24V AC, 30 VA	Rating Built-In Transformer

2500 RAINSWITCH-READY CONTROLLERS

2510	Voltage Input: 110V AC, 60 Hz Output: 110V AC, 60 Hz	Rating Double Pole, Single Throw Relay Rated for up to 2 H.P.
2514	Voltage Input: 110V AC, 60 Hz Output: 24V AC, 30 VA	Rating Built-In Transformer
2520	Voltage Input: 220V AC, 60 Hz Output: 220V AC, 60 Hz	Rating Double Pole, Single Throw Relay Rated for up to 2 H.P.





4000 SERIES INDEXING VALVE

A reliable, economical way to automate multiple zoned residential and small commercial irrigation systems.

Application: Residential / Commercial



These patented indexing valves allow for the number of watering zones to be changed quickly and easily. Ideally suited for both city water and pump applications, and may also be used for onsite wastewater or effluent water applications. The simplicity of design and few moving parts ensures ease of maintenance and long service life.

Available in 4 or 6 outlet models. A quick change of the cam allows the valve to operate from 2 to 6 zones. The valve will operate with flows as low as 10 GPM (38 LPM) and at pressures of 25 to 75 PSI (1,7 to 5,2 bar).

Specifications

- Constructed of High Strength, Non-Corrosive ABS Polymer
- 4000 Series Valves are available with 1" (2,5 cm) inlet and outlet by custom order

OPERATING SPECIFICATIONS

- Pressure Rating: 25 – 75 PSI (1,7 to 5,2 bar)
- Flow Range:
 - 4 Outlet Valve: 10-40 GPM (38-150 LPM)
 - 6 Outlet Valve: 10-30 GPM (38-113,5 LPM)
- Pressure Loss:

4 OUTLET VALVE

Flow Rate - GPM	10	20	30	40
PSI Loss	2.0	3.0	4.5	6.4

6 OUTLET VALVE

Flow Rate - GPM	10	20	30
PSI Loss	2.5	4.5	7.5

DIMENSIONS

- Height: 5 3/4" (14,6 cm)
- Width: 5 3/4" (14,6 cm)

Features and Benefits

- ABS Polymer Construction** – High-strength, non-corrosive body for long product life.
- Available in 4 and 6 Outlet Models** – Can quickly and easily change from two to six watering zones.
- Simplicity of Design** – Valves are easily maintained and serviced for long product life.
- Operates at Low 10 GPM (38 LPM) at Pressures of 25-75 PSI (1,7-5,2 bar)** – Reliably automates multiple zoned residential and small commercial irrigation or wastewater systems.

Models

FOUR OUTLET MODELS

1 1/4" X 1 1/4" (3,2 CM X 3,2 CM)

4400	No Cam
4402	Cammed for 2 Zone Operation
4403	Cammed for 3 Zone Operation
4404	Cammed for 4 Zone Operation

SIX OUTLET MODELS

1 1/4" X 1" (3,2 CM X 2,5 CM)

4600	No Cam
4602	Cammed for 2 Zone Operation
4603	Cammed for 3 Zone Operation
4604	Cammed for 4 Zone Operation
4605	Cammed for 5 Zone Operation
4606	Cammed for 6 Zone Operation

Other options add to part number:

-RCW Reclaimed Water Use

6000 SERIES INDEXING VALVE

The 6000 line of indexing valves offers exceptional reliability and durability even under the dirtiest water conditions.

Application: Industrial



With a metal die-cast body, the 6000 valves are capable of high pressure applications and are recommended to be used on pump fed systems or high-flow city water systems. The 6000 is also ideal for onsite wastewater and effluent water applications.

The 6000 valve is available in 4 or 6 outlet models that are cammed for 2 to 6 zone operation. With only one moving part (the stem and disc assembly), the valve is easily serviced and maintained.

The valve requires 15 GPM (57 LPM) to operate and works at pressures from 25 to 150 PSI (1,7 to 10,3 bar).

Features and Benefits

- **Metal Die-Cast Body** – Durable, long lasting and capable of high pressure applications.
- **Available in 4 and 6 Outlet Models** – Can quickly and easily change from two to six watering zones.
- **Simplicity of Design** – Valves are easily maintained and serviced for long product life.
- **Operates at 15 GPM (57 LPM) at Pressures of 25–150 PSI (1,7-10,3 bar)** – Ideal for pump-fed systems or high-flow city water systems.
- **Built-in Atmospheric Vacuum Breaker** – Releases any vacuum created between the pump and the valve on shut down.

Models

FOUR OUTLET MODELS

- 6402** Cammed for 2 Zone Operation
- 6403** Cammed for 3 Zone Operation
- 6404** Cammed for 4 Zone Operation

SIX OUTLET MODELS

- 6605** Cammed for 5 Zone Operation
- 6606** Cammed for 6 Zone Operation

Other options add to part number:

- RCW** Reclaimed Water Use

Specifications

- **Construction:**
Valve Top/Housing: Die Cast Metal
Valve Outlets: High Strength ABS Polymer
- **Inlet:** Threaded 1 1/2" (3,8 cm) NPT Connection
- **Outlets:** Slip and Glue Connections to 1 1/2" (3,8 cm) PVC Pipe

OPERATING SPECIFICATIONS

- **Pressure Rating:** 25 - 150 PSI (1,7 to 10,3 bar)
- **Flow Range:** 15-150 GPM (57-568 LPM)
- **Pressure Loss:**

4 OUTLET VALVE

Flow Rate - GPM	20	40	60	80	100
PSI Loss	2.5	3.5	5.0	7.5	10.0

6 OUTLET VALVE

Flow Rate - GPM	20	40	60	80	100
PSI Loss	3.0	4.0	6.0	9.0	11.0

DIMENSIONS

- **Height:** 7" (17,8)
- **Width:** 8" (20,3)



PROPLUS® RCW

Application: Residential / Commercial, Reclaimed Water

The ProPlus® RCW Rotor provides excellent nozzle performance and delivers an exceptional fall out pattern.

In independent testing by C.I.T., the ProPlus® delivered up to 90% uniform coverage.

Low Angle Performance Data

NOZZLE	PRESSURE			RADIUS		FLOW RATE			PRECIPITATION			
	PSI	kPa	Bars	Ft.	M.	GPM	L/M	M ³ /H	■ in/hr ▲	■ mm/hr ▲		
#1.0	30	207	2,1	22	6,7	1.2	4,5	0,27	0.48	0.55	12	14
	40	276	2,8	24	7,3	1.7	6,4	0,39	0.57	0.66	14	17
	50	345	3,4	26	7,9	1.8	6,8	0,41	0.51	0.59	13	15
	60	414	4,1	28	8,5	2.0	7,6	0,45	0.49	0.57	12	14
#3.0	30	207	2,1	29	8,8	3.0	11,4	0,68	0.69	0.79	17	20
	40	276	2,8	32	9,8	3.1	11,7	0,70	0.58	0.67	15	17
	50	345	3,4	35	10,7	3.5	13,2	0,80	0.55	0.64	14	16
	60	414	4,1	37	11,3	3.8	14,4	0,86	0.53	0.62	14	16
#4.0	30	207	2,1	31	9,4	3.4	12,9	0,77	0.68	0.79	17	20
	40	276	2,8	34	10,4	3.9	14,8	0,89	0.65	0.75	17	19
	50	345	3,4	37	11,3	4.4	16,7	1,00	0.62	0.71	16	18
	60	414	4,1	38	11,6	4.7	17,8	1,07	0.63	0.72	16	18
#6.0	40	275	2,8	38	11,6	6.5	24,6	1,48	0.87	1.00	22	25
	50	344	3,4	40	12,2	7.3	27,7	1,66	0.88	1.01	22	26
	60	413	4,1	42	12,8	8.0	30,3	1,82	0.87	1.01	22	26
	70	482	4,8	44	13,4	8.6	32,6	1,96	0.86	0.99	22	25

*All precipitation rates calculated for 180° operation. For the precipitation rate for a 360° sprinkler, divide by 2.



Specifications

- Inlet: (1,9 cm) 3/4" Threaded NPT
- Arc Adjustment Range: 40° to Continuous 360°
- Flow Range: .5 – 10.0 GPM (1,9 – 37,8 LPM)
- Pressure Rating: 20 – 70 PSI (2 – 4,8 bars)
- Precipitation Rate: .12 – .89 in/hr (3 – 26 mm/hr) (Depending on Spacing and Nozzle Used)
- Overall Height (Popped Down): 7 1/2" (19 cm) (17" (43,2 cm) for High Pop Model)
- Recommended Spacing: 28' – 44' (8,5 – 13,2 m)
- Radius: 22' – 50' (6,7 – 15,3 m)
- Low Angle Nozzle Trajectory: 12°
- Standard and Low Angle Nozzles Included
- Riser Height: 4" (10,2 cm) and 12" (30,5 cm)

Models

11003-RCW ProPlus® for Reclaimed Water Use

Easy Arc Setting

Arc Selection 40° to Continuous 360°
Adjust From Left Start

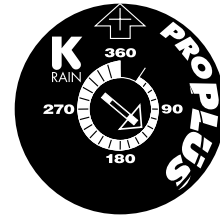

Features and Benefits

- **Revolutionary Patented Top Arc Set** – Simplified arc set allows for wet or dry adjustment in seconds.
- **4" (10,2 cm) Riser** – Perfect for grasses with thick thatch.
- **3/4" (1,9 cm) Inlet** – Replaces all standard rotors.
- **2N1 Adjustable or Continuous Rotation** – Provides a full range adjustment from 40° to a continuous full circle.
- **Patented Arc Set Degree Markings** – Clearly indicates current watering pattern & simplifies arc set adjustment.
- **Arc Memory Clutch** – Prevents internal gear damage and returns rotor to its prior setting automatically if nozzle turret is forced past its stop.
- **Time Proven Patented Reversing Mechanism** – Assures continuous reverse and return...over a 35 year history.
- **Ratcheting Riser** – Allows for easy adjustment of your fixed starting position with a simple turn of the riser.
- **Rubber Cover** – Seals out dirt, increases product durability.

RCW SERIES

Rotors, Sprays and Indexing Valves for Reclaimed Water

K-Rain® is the leading manufacturer of Rotors, Sprays and Distribution Valves for the reclaimed water industry.

The process of reclaiming water, also called “water recycling”, involves a highly engineered, multi-step treatment process that speeds up water reclamation.

Worldwide regulations frequently require reclaimed water usage sites to use components identified with a purple cap or collar. K-Rain® manufactures an entire line of rotors, sprays and indexing valves to help you adhere to these rules.

The K-Rain® RCW series is designed specifically for use on reclaimed water systems. Flexibility in system design, achieved through a wide selection of nozzles, guarantees matched precipitation.

RCW models are available in K-Spray™ and Pro-S™ Sprays, MiniPro®, ProPlus®, RPS™ 75, SuperPro® and ProSport® Rotors, and the 4000 and 6000 series indexing valves.



Features and Benefits

RCW ROTORS

- **Heavy Duty Rubber Cover (purple)** – Seals out dirt and increases product durability, positively identifies the use of reclaimed water reducing liability.

RCW SPRAYS

- **Accepts Low Angle Nozzle** – Ensures the correct trajectory of reclaimed water.

RCW INDEXING VALVES

- **Available in 4 and 6 Outlet Models** – Watering zones can be changed quickly and easily.
- **4000 RCW Indexing Valve** – Automates multiple zoned residential and small commercial wastewater systems.
- **6000 RCW Indexing Valve** – Metal die-cast body is capable of high pressure applications.

Models

Please refer to product pages for individual product model numbers and performance data.

PRODUCT	PAGE
MiniPro®	04
RPS™ 75	08
SuperPro®	14
ProSport®	16
Pro-S™	18
K-Spray™	21
4000 Series Valves	50
6000 Series Valves	51



ACCESSORIES

Nozzle Racks

Item Number	Item Description
P52775	MiniPro® Nozzle Rack (red) .75, 1, 2, 3 GPM nozzles included (1.5 GPM nozzle preinstalled)
P51399	ProPlus® Nozzle Rack (red) 0.5, 0.75, 1, 2, 3, 4, 6, 8 GPM standard nozzles and 1, 3, 4, 6 GPM low angle nozzles included (2.5 GPM nozzle preinstalled)
P16001101	RPS™ 75 Nozzle Rack (red) 0.75, 1, 1.5, 2, 4, 6, 8 GPM standard nozzles and 1, 3, 4, 6 GPM low angle nozzles included (3.0 GPM nozzle preinstalled)
P16001110	RPS™ 75i, SuperPro Nozzle Rack (green) 1, 1.5, 2, 2.5, 3, 4, 5, 6, 8 GPM standard nozzles and 1, 1.5, 2, 3 GPM low angle nozzles included (2.5 GPM nozzle preinstalled)



MiniPro®
Nozzle Rack

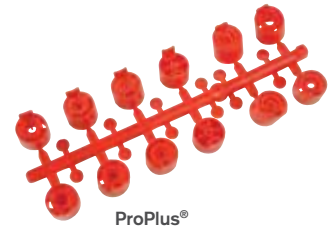

ProPlus®
Nozzle Rack



RPS™ 75
Nozzle Rack

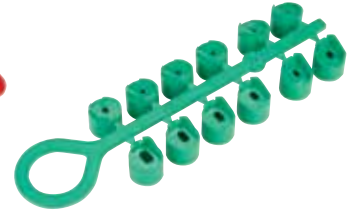

RPS™ 75i, SuperPro
Nozzle Rack

ProSport® Replacement Nozzles

Item Number	Item Description
P55519	5 GPM (18,9 LPM), white Includes 10 GPM (37,9 LPM), green 12 nozzles in each bag 15 GPM (56,8 LPM), grey 20 GPM (75,7 LPM), brown 25 GPM (94,6 LPM), blue 30 GPM (113,5 LPM), black



ProSport®
Nozzles

How to Specify: Model Number: P55519 Description: -5

Adjustment Tools

Item Number	Item Description
P59995	K-Key; MiniPro®, ProPlus® Adjustment Key
P1000902	SuperPro®, RPS™ Select, ProSport® Adjustment Key
P1000901	RPS™ 75, RPS™ 75i Adjustment Key
RN-ADJ-TOOL	Rotary Nozzle Adjustment Tool



K-Key; MiniPro®, ProPlus®
Adjustment Key



ProSport®, SuperPro®
and RPS™ Select
Adjustment Key



RPS™ 75, RPS™ 75i
Adjustment Key



Rotary Nozzle
Adjustment Tool

Swing Pipe Accessories

Item Number	Item Description
SWPC050	Swing Pipe, Coupling, 1/2" Barb
SWPT050	Swing Pipe, Tee, 1/2" Barb
SWPE050	Swing Pipe, Elbow, 1/2" MNPT x 1/2" Barb
SWPE075	Swing Pipe, Elbow, 3/4" MNPT x 1/2" Barb



Swing Pipe, Coupling



Swing Pipe, Tee







Swing Pipe, Elbow,
1/2" MNPT







Swing Pipe, Elbow,
3/4" MNPT

Rotor Accessories

Item Number	Item Description	Riser Clip	MiniPro® Check Disk	RPS™ 75, 75i, Select Check Disk Assembly	ProSport® Check Disk	ProPlus®, SuperPro® Check Disk
P54065	Riser Clip					
P513995	MiniPro® Check Disk					
P16009110	RPS™ 75, 75i, Select Check Disk Assembly					
P53425	ProSport® Check Disk					
P51210	ProPlus®, SuperPro® Check Disk					
P51114	MiniPro® Filter Basket		MiniPro® Filter Basket			
P51115	RPS™ 75, 75i, Select Filter Basket			RPS™ 75, 75i, Select Filter Basket		
P51112	ProPlus®, SuperPro® Filter Basket				ProPlus®, SuperPro® Filter Basket	

Spray Accessories

Item Number	Item Description	Female Shrub Adapter	Male Shrub Adapter	Female Shrub Adapter, RCW	Male Shrub Adapter, RCW
PSA	Shrub Adapter, Female Thread (for male nozzles)				
PFSA	Shrub Adapter, Male Thread (for female nozzles)				
PFSA-RCW	RCW Shrub adapter, Male Thread, (for female nozzles)				
PSA-RCW	RCW Shrub adapter, Female Thread, (for male nozzles)				
P53426	K-Spray™ Check Disk	K-Spray™ Check Disk			
P53428	Pro-S™ Check Disk	Pro-S™ Check Disk			
P53429	NP Spray™ Check Disk	NP Spray™ Check Disk			
78000	Rotary Nozzle Guard (fits Pro-S™ Sprays)				Rotary Nozzle Guard

Valve Accessories

P3008114	9V DC Latching Solenoid				
P3008113	24V AC Solenoid				
P3004750	Replacement K-Rain® 24V solenoid with 1 each Rain Bird® and Hunter® adapters				
P3004758	Replacement K-Rain® 9V solenoid with 1 each Rain Bird® and Hunter® adapters				
P3004760	1 Rain Bird® and 1 Hunter® adapters for K-Rain® 24V solenoid				
P3004770	5 K-Rain 24V solenoid adapters for Rain Bird®				
P3004780	5 K-Rain 24V solenoid adapters for Hunter®				

Pro Ex 2.0 Accessories

3203	Pro EX 2.0 handheld remote w/batteries				
3205	ProEX 2.0, 4 station expansion module				
3206	RF module w/short distance antenna				
3207	Extended range antenna kit				
3209	WiFi hub for Pro EX 2.0 Controller				



CHARTS

Conversion Table for U.S. and Metric Systems

METRIC TO U.S.			
MULTIPLY		TO OBTAIN	
Millimeters (mm)	x	.03937	= inches
Centimeters (cm)	x	.3937	= inches
Meters (m)	x	39.37	= inches
Meters (m)	x	3.281	= feet
Meters (m)	x	1.094	= yards
Kilometers (km)	x	.62137	= miles
Kilometers (km)	x	1093.62	= yards
Kilometers (km)	x	3280.87	= feet
Liters (l)	x	1.0567	= quarts (liq.)
Liters (l)	x	.2642	= gallons (U.S.)
Liters (l)	x	.455	= pounds
Temp. in (C° x 1.80)	+	32°	= temp. in F°

U.S. TO METRIC			
MULTIPLY		TO OBTAIN	
Inches (in.)	x	25.4	= millimeters
Inches (in.)	x	2.54	= centimeters
Inches (in.)	x	.0254	= meters
Feet (ft.)	x	.3048	= meters
Yards (yds.)	x	.9144	= meters
Miles (mi.)	x	1.6093	= kilometers
Yards (yds.)	x	.0009143	= kilometers
Feet (ft.)	x	.0003048	= kilometers
Quarts (qts.)	x	.945	= liters
Gallons	x	3.78	= liters
Pounds	x	2.2	= liters
Temp. in F° - 32°	x	.5666	= temp. in C°

Kilograms per cubic centimeter (kg/cm²)	x	14.223	=	Pounds per square inch (P.S.I.)
Cubic Foot (cu. ft.) x 28.316			=	Liters (l.)

MISCELLANEOUS CONVERSION FACTORS					
Feet head (ft. hd.) x .433	=	Pounds per square inch (P.S.I.)	Calorie x 3.968	=	British Thermal Unit (B.T.U.)
Pounds per square inch x 2.31	=	Feet head	Foot pounds per second x .7373	=	Watts
Meters x 3.28	=	Feet head	Kilowatts x 1.34	=	Horsepower
Inches of mercury x 1.133	=	Feet head	Square foot x 144	=	Square inches
U.S. gallons per minute x .1337	=	Cubic feet per minute	Square yard x 9	=	Square feet
Cubic feet per minute x 7.48	=	U.S. gallons per minute	Acre x 4.840	=	Square yards
British Imperial gallon x 1.201	=	U.S. gallons	Acre x 43,560	=	Square feet
Acre inches per hour x 453	=	G.P.M.	Square mile (section) x 640	=	Acres
Acre foot per day x 226	=	G.P.M.	Mile x 5280	=	Feet
1,000,000 gallons per day	=	694 G.P.M.	Cubic yard x 27	=	Cubic Feet
U.S. gallons x .833	=	British Imperial gallon	Circumference of circe x .3183	=	Diameter of circle
U.S. gallon x 8.336	=	Pounds	Diameter of circe x 3.1416	=	Circumference of circle
Acre foot x 325,850	=	U.S. gallons	Diameter of circle squared x .7854	=	Area of circle
Gallons per day x 1,000,000	=	694 gallons per minute	Radius of circle squared x 3.1416	=	Area of circle
U.S. gallons x 231	=	Cubic inches	Cubic Feet per second x 448.8	=	U.S. gallons per minute
Horsepower (H.P.) x 746	=	Watts	Cubic feet per second	=	Gallons per minute - 449
Horsepower x .746	=	Kilowatts	Velocity in feet per second	=	$\frac{.408 \times \text{U.S. g.p.m.}}{\text{Diam. of pipe squared}}$
					or
					$\frac{144Q (\text{flow in G.P.M.})}{A1 (\text{Pipe ID}^2)}$

CHARTS

Resistance and Valve Wire Sizing

Resistance Method

Required Information

- Actual one-way length of wire between the controllers and at the power source of the controllers and valves
- Allowable voltage loss along the wire circuit
- Accumulative current flowing through the wire section being sized in amperes

Resistance is calculated using formula:

$$R = \frac{1000 \times AVL}{2L \times I}$$

R = Maximum Allowable Resistance of wire in ohms per 1000 feet

AVL = Allowable voltage loss

L = Wire length (one way)

I = Inrush current

AVL for controller power wire sizing is calculated by subtracting minimum operating voltage required by the controller from minimum available voltage at power source.

AVL for valve wire sizing is calculated by subtracting minimum solenoid operating voltage from controller output voltage. This number will vary depending on the manufacturer and in some cases with line pressure.

Valve Wire Sizing Example:

Given: The distance from the controller to the valve is 1800 ft. The controller output is 24V. The valve has a minimum operating voltage of 20V and an inrush current of 370 mA (0.37Amps).

$$R = \frac{1000 \times 4}{2(1800) \times 0.37}$$

$$R = \frac{4000}{332}$$

$$R = 3.00 \text{ ohms/1000 feet}$$

Wire resistance can not exceed 3.00 ohms per 1000 feet. Go to table #1 and select the proper wire size. Since 16 gauge wire has more resistance than 3.00 ohms per 1000 feet, choose 14 gauge wire.

Table 2 is a quick reference and is set up to provide maximum wire runs given the information at the bottom of the table.

TABLE 1

Resistance of Copper Wire

WIRE SIZE AWG No.	Resistance at 20° C (68° F) ohms per 1000 Feet
18	6.39
16	4.02
14	2.52
12	1.59
10	1.00
8	0.63
6	0.40
4	0.25

TABLE 2

Valve Wire Sizing (Maximum One-Way Distance in Feet Between Controller and Valve)

GROUND WIRE	CONTROL WIRE						
	18	16	14	12	10	8	6
18	850	1040	1210	1350	1460	1540	1590
16	1040	1340	1650	1920	2150	2330	2440
14	1210	1650	2150	2630	3080	3450	3700
12	1350	1920	2630	3390	4170	4880	5400
10	1460	2150	3080	4170	5400	6670	7690
8	1540	2330	3450	4880	6670	8700	10530
6	1590	2440	3700	5400	7690	10530	13330

Solenoid: 24VAC, Pressure: 150 PSI, Voltage Drop: 4V, Min. Operating Voltage: 20V, Amperage Peak: .37A

FORMULAS

PRECIPITATION RATES	(U.S.)	(METRIC)
Equilateral Triangular Spacing	P.R.= (in/hr) $\frac{(GPM \text{ of } 360) \times 96.25}{(Head \text{ Spacing})^2 \times .866}$	P.R.= (mm/hr) $\frac{m3/hr \text{ of } 360 \times 1000}{m^2 \times .866}$
Square/Rectangular Spacing	P.R.= (in/hr) $\frac{(GPM \text{ of } 360) \times 96.25}{Head \text{ Spacing} \times Row \text{ Spacing}}$	P.R.= (mm/hr) $\frac{m3/hr \text{ of } 360 \times 1000}{Head \text{ Spacing} \times Row \text{ Spacing}}$
Square/Rectangular Spacing for Specific Arc	P.R.= (in/hr) $\frac{3460 \times GPM \text{ (for any arc)}}{Degrees \text{ of Arc} \times Head \text{ Spacing} \times Row \text{ Spacing}}$	P.R.= (mm/hr) $\frac{m3/hr \text{ (for any arc)} \times 1000}{Degrees \text{ of Arc} \times Head \text{ Spacing} \times Row \text{ Spacing}}$
Horsepower	H.P. = $\frac{GPM \times Ft \text{ of Head}}{3,960 \times Pump \text{ Efficiency (expressed as a decimal)}}$	
Station Run Time	S.R.T. = (min/wk) $\frac{Total \text{ Weekly Req'd (inch/wk)} \times 60 \text{ (min/hr)}}{Precipitation \text{ Rate (in/hr)}}$	S.R.T.= (min/wk) $\frac{Total \text{ Weekly Req'd (mm/wk)} \times 60 \text{ (min/hr)}}{Precipitation \text{ Rate (mm/hr)}}$
Pipe Velocity	V= (ft/sec) $\frac{0.4085 \times Flow \text{ (GPM)}}{(Inside \text{ Pipe Diameter in Inches})^2}$	V= (m/sec) $\frac{1273.24 \times Flow \text{ (l/sec)}}{(Inside \text{ Pipe Diameter in Millimeters})^2}$
Scheduling Coefficient	S.C.= $\frac{Average \text{ Precipitation Rate (in/hr)}}{Lowest \text{ Precipitation Rate (in/hr)}}$	S.C.= $\frac{Average \text{ Precipitation Rate (mm/hr)}}{Lowest \text{ Precipitation Rate (mm/hr)}}$
Slope	S= $\frac{Rise \text{ (Measure of Length)}}{Run \text{ (Measure of Length)}}$	

CHARTS

PVC Schedule 40 IPS Plastic Pipe

SIZES: 1/2" – 6" **FLOW:** 1 – 600 GPM **PSI LOSS:** Per 100' of tube (PSI/100 FT) **C = 150 (1120, 1220)**

SIZE	1/2"		3/4"		1"		1 1/4"		1 1/2"		2"		2 1/2"		3"		4"		6"		
OD	0.840		1.050		1.315		1.660		1.900		2.375		2.875		3.500		4.500		6.625		
ID	0.622		0.824		1.049		1.380		1.610		2.067		2.469		3.068		4.026		6.065		
WALL THK.	0.109		0.113		0.133		0.140		0.145		0.154		0.203		0.216		0.237		0.280		
FLOW G. P. M.	Velocity FPS	psi Loss	Velocity FPS	psi Loss	Velocity FPS	psi Loss	Velocity FPS	psi Loss	Velocity FPS	psi Loss	Velocity FPS	psi Loss	Velocity FPS	psi Loss	Velocity FPS	psi Loss	Velocity FPS	psi Loss	Velocity FPS	psi Loss	
1	1.05	0.43	0.60	0.11	0.37	0.03	0.21	0.01	0.15	0.00											
2	2.11	1.55	1.20	0.39	0.74	0.12	0.42	0.03	0.31	0.02	0.19	0.00									
3	3.16	3.28	1.80	0.84	1.11	0.26	0.64	0.07	0.47	0.03	0.28	0.01	0.20	0.00							
4	4.22	5.60	2.40	1.42	1.48	0.44	0.85	0.12	0.62	0.05	0.38	0.02	0.26	0.01							
5	5.27	8.46	3.00	2.15	1.85	0.66	1.07	0.18	0.78	0.08	0.47	0.02	0.33	0.01	0.21	0.00					
6	6.33	11.86	3.60	3.02	2.22	0.93	1.28	0.25	0.94	0.12	0.57	0.03	0.40	0.01	0.26	0.01					
7	7.38	15.77	4.20	4.01	2.59	1.24	1.49	0.33	1.10	0.15	0.66	0.05	0.46	0.02	0.30	0.01					
8	8.44	20.20	4.80	5.14	2.96	1.59	1.71	0.42	1.25	0.20	0.76	0.06	0.53	0.02	0.34	0.01					
9	9.49	25.12	5.40	6.39	3.33	1.97	1.92	0.52	1.41	0.25	0.85	0.07	0.60	0.03	0.39	0.01					
10	10.55	30.54	6.00	7.77	3.70	2.40	2.14	0.63	1.57	0.30	0.95	0.09	0.66	0.04	0.43	0.01					
11	11.60	36.43	6.60	9.27	4.07	2.86	2.35	0.75	1.73	0.36	1.05	0.11	0.73	0.04	0.47	0.02					
12	12.65	42.80	7.21	10.89	4.44	3.36	2.57	0.89	1.88	0.42	1.14	0.12	0.80	0.05	0.52	0.02	0.30	0.00			
14	14.76	56.94	8.41	14.48	5.19	4.47	2.99	1.18	2.20	0.56	1.33	0.17	0.93	0.07	0.60	0.02	0.35	0.01			
16	16.87	72.92	9.61	18.55	5.93	5.73	3.42	1.51	2.51	0.71	1.52	0.21	1.07	0.09	0.69	0.03	0.40	0.01			
18	18.98	90.69	10.81	23.07	6.67	7.13	3.85	1.88	2.83	0.89	1.71	0.26	1.20	0.11	0.78	0.04	0.45	0.01			
20	21.09	110.23	12.01	28.04	7.41	8.66	4.28	2.28	3.14	1.08	1.90	0.32	1.33	0.13	0.86	0.05	0.50	0.01			
22			13.21	33.45	8.15	10.33	4.71	2.72	3.46	1.29	2.10	0.38	1.47	0.16	0.95	0.06	0.55	0.01			
24			14.42	39.30	8.89	12.14	5.14	3.20	3.77	1.51	2.29	0.45	1.60	0.19	1.04	0.07	0.60	0.02			
26			15.62	45.58	9.64	14.08	5.57	3.17	4.09	1.75	2.48	0.52	1.74	0.22	1.12	0.08	0.65	0.02			
28			16.82	52.28	10.38	16.15	5.99	4.25	4.40	2.01	2.67	0.60	1.87	0.25	1.21	0.09	0.70	0.02			
30			18.02	59.41	11.12	18.35	6.42	4.83	4.72	2.28	2.86	0.68	2.00	0.29	1.30	0.10	0.75	0.03			
35					12.97	24.42	7.49	6.43	5.50	3.04	3.34	0.90	2.34	0.38	1.51	0.13	0.88	0.04	0.38	0.00	
40					14.83	31.27	8.56	8.23	6.29	3.89	3.81	1.15	2.67	0.49	1.73	0.17	1.00	0.04	0.44	0.01	
45					16.68	38.89	9.64	10.24	7.08	4.84	4.29	1.43	3.01	0.60	1.95	0.21	1.13	0.06	0.49	0.01	
50					18.53	47.27	10.71	12.45	7.87	5.88	4.77	1.74	3.34	0.73	2.16	0.26	1.25	0.07	1.55	0.01	
55							11.78	14.85	8.65	7.01	5.25	2.08	3.68	0.88	2.38	0.30	1.38	0.08	0.61	0.01	
60							12.85	17.45	9.44	8.24	5.72	2.44	4.01	1.03	2.60	0.36	1.51	0.10	0.66	0.01	
65							13.92	20.23	10.23	9.56	6.20	2.83	4.35	1.19	2.81	0.41	1.63	0.11	0.72	0.02	
70							14.99	23.21	11.01	10.96	6.68	3.25	4.68	1.37	3.03	0.48	1.76	0.13	0.77	0.02	
75							16.06	26.37	11.80	12.46	7.16	3.69	5.01	1.56	3.25	0.54	1.88	0.14	0.83	0.02	
80							17.13	29.72	12.59	14.04	7.63	4.16	5.35	1.75	3.46	0.61	2.01	0.16	0.88	0.02	
85							18.21	33.26	13.37	15.71	8.11	4.66	5.68	1.96	3.68	0.68	2.13	0.18	0.94	0.02	
90							19.28	36.97	14.16	17.46	8.59	5.18	6.02	2.18	3.90	0.76	2.26	0.20	0.99	0.03	
95									14.95	19.30	9.07	5.72	6.35	2.41	4.11	0.84	2.39	0.22	1.05	0.03	
100									15.74	21.22	9.54	6.29	6.69	2.65	4.33	0.92	2.51	0.25	1.10	0.03	
110									17.31	25.32	10.50	7.51	7.36	3.16	4.76	1.10	2.76	0.29	1.22	0.04	
120									18.88	29.75	11.45	8.82	8.03	3.72	5.20	1.29	3.02	0.34	1.33	0.05	
130											12.41	10.23	8.70	4.31	5.63	1.50	3.27	0.40	1.44	0.05	
140											13.36	11.74	9.37	4.94	6.06	1.72	3.52	0.46	1.55	0.06	
150											14.32	13.33	10.03	5.62	6.50	1.95	3.77	0.52	1.66	0.07	
160											15.27	15.03	10.70	6.33	6.93	2.20	4.02	0.59	1.77	0.08	
170											16.23	16.81	11.37	7.08	7.36	2.46	4.27	0.66	1.88	0.09	
180											17.18	18.69	12.04	7.87	7.80	2.74	4.53	0.73	1.99	0.10	
190											18.14	20.66	12.71	8.70	8.23	3.02	4.78	0.81	2.10	0.11	
200											19.09	22.72	13.38	9.57	8.66	3.33	5.03	0.89	2.21	0.12	
225													15.05	11.90	9.75	4.14	5.66	1.10	2.49	0.15	
250													16.73	14.47	10.83	5.03	6.29	1.34	2.77	0.18	
275													18.40	17.26	11.92	6.00	6.92	1.60	3.05	0.22	
300															13.00	7.05	7.55	1.88	3.32	0.26	
325															14.08	8.17	8.18	2.18	3.60	0.30	
350															15.17	9.38	8.81	2.50	3.88	0.34	
375															16.25	10.65	9.43	2.84	4.15	0.39	
400															17.33	12.01	10.06	3.20	4.43	0.44	
425															18.42	13.43	10.69	3.58	4.71	0.49	
450															19.50	14.93	11.32	3.98	4.99	0.54	
475																11.95	4.40	5.26	0.60		
500																12.58	4.84	5.54	0.66		
550																13.84	5.77	6.10	0.79		
600																15.10	6.78	6.65	0.92		

Note: Shaded areas of the chart indicate velocities over 5 feet per second (FPS). Use with caution.

CHARTS

PVC Schedule 80 IPS Plastic Pipe

SIZES: 1/2" – 6" **FLOW:** 1 – 600 GPM **PSI LOSS:** Per 100' of tube (PSI/100 FT) **C = 150 (1120, 1220)**

SIZE	1/2"		3/4"		1"		1 1/4"		1 1/2"		2"		2 1/2"		3"		4"		6"	
OD	0.840		1.050		1.315		1.660		1.900		2.375		2.875		3.500		4.500		6.625	
ID	0.546		0.742		0.957		1.278		1.500		1.939		2.323		2.900		3.826		5.761	
WALL THK.	0.147		0.154		0.179		0.191		0.200		0.218		0.276		0.300		0.337		0.432	
FLOW G. P. M.	Velocity FPS	psi Loss	Velocity FPS	psi Loss	Velocity FPS	psi Loss	Velocity FPS	psi Loss	Velocity FPS	psi Loss	Velocity FPS	psi Loss	Velocity FPS	psi Loss	Velocity FPS	psi Loss	Velocity FPS	psi Loss	Velocity FPS	psi Loss
1	1.36	0.81	0.74	0.18	0.44	0.05	0.24	0.01	0.18	0.01	0.10	0.00								
2	2.73	2.92	1.48	0.66	0.89	0.19	0.49	0.05	0.36	0.02	0.21	0.01	0.15	0.00						
3	4.10	6.19	2.22	1.39	1.33	0.40	0.74	0.10	0.54	0.05	0.32	0.01	0.22	0.01						
4	5.47	10.54	2.96	2.37	1.78	0.69	0.99	0.17	0.72	0.08	0.43	0.02	0.30	0.01						
5	6.84	15.93	3.70	3.58	2.22	1.04	1.24	0.25	0.90	0.12	0.54	0.03	0.37	0.01	0.24	0.00				
6	8.21	22.33	4.44	5.02	2.67	1.46	1.49	0.36	1.08	0.16	0.65	0.05	0.45	0.02	0.29	0.01				
7	9.58	29.71	5.18	6.68	3.11	1.94	1.74	0.47	1.26	0.22	0.75	0.06	0.52	0.03	0.33	0.01				
8	10.94	38.05	5.92	8.56	3.56	2.48	1.99	0.61	1.45	0.28	0.86	0.08	0.60	0.03	0.38	0.01				
9	12.31	47.33	6.66	10.64	4.00	3.09	2.24	0.76	1.63	0.35	0.97	0.10	0.68	0.04	0.43	0.01				
10	13.68	57.52	7.41	12.93	4.45	3.75	2.49	0.92	1.81	0.42	1.08	0.12	0.75	0.05	0.48	0.02	0.27	0.00		
11	15.05	68.63	8.15	15.43	4.90	4.47	2.74	1.10	1.99	0.50	1.19	0.14	0.83	0.06	0.53	0.02	0.30	0.01		
12	16.42	80.63	8.89	18.13	5.34	5.26	2.99	1.29	2.17	0.59	1.30	0.17	0.90	0.07	0.58	0.02	0.33	0.01		
14			10.37	24.12	6.23	6.99	3.49	1.71	2.53	0.79	1.51	0.23	1.05	0.09	0.67	0.03	0.39	0.01		
16			11.85	30.88	7.12	8.95	3.99	2.19	2.90	1.01	1.73	0.29	1.20	0.12	0.77	0.04	0.44	0.01		
18			13.33	38.41	8.01	11.14	4.49	2.73	3.26	1.26	1.95	0.36	1.36	0.15	0.87	0.05	0.50	0.01		
20			14.82	46.69	8.90	13.54	4.99	3.31	3.62	1.52	2.17	0.44	1.51	0.18	0.97	0.06	0.55	0.02		
22			16.30	55.70	9.80	16.15	5.49	3.95	3.98	1.81	2.38	0.52	1.66	0.22	1.06	0.07	0.61	0.02		
24			17.78	65.44	10.69	18.97	5.99	4.64	4.35	2.13	2.60	0.61	1.81	0.25	1.16	0.09	0.66	0.02		
26			19.26	75.90	11.58	22.01	6.49	5.39	4.71	2.47	2.82	0.71	1.96	0.29	1.26	0.10	0.72	0.03		
28					12.47	25.24	6.99	6.18	5.07	2.83	3.03	0.81	2.11	0.34	1.35	0.11	0.78	0.03		
30					13.36	28.69	7.49	7.02	5.43	3.22	3.25	0.92	2.26	0.38	1.45	0.13	0.83	0.03	0.36	0.00
35					15.59	38.16	8.74	9.34	6.34	4.29	3.79	1.23	2.64	0.51	1.69	0.17	0.97	0.05	0.43	0.01
40					17.81	48.87	9.99	11.96	7.25	5.49	4.34	1.57	3.02	0.65	1.94	0.22	1.11	0.06	0.49	0.01
45							11.24	14.88	8.16	6.83	4.88	1.96	3.40	0.81	2.18	0.28	1.25	0.07	0.55	0.01
50							12.49	18.09	9.06	8.30	5.42	2.38	3.78	0.99	2.42	0.34	1.39	0.09	0.61	0.01
55							13.73	21.58	9.97	9.90	5.96	2.84	4.15	1.18	2.66	0.40	1.53	0.10	0.67	0.01
60							14.98	25.35	10.87	11.63	6.51	3.33	4.53	1.38	2.91	0.47	1.67	0.12	0.73	0.02
65							16.23	29.40	11.78	13.49	7.05	3.87	4.91	1.61	3.15	0.55	1.81	0.14	0.79	0.02
70							17.48	33.72	12.69	15.47	7.59	4.44	5.29	1.84	3.39	0.63	1.95	0.16	0.86	0.02
75							18.73	38.32	13.59	17.58	8.13	5.04	5.67	2.09	3.63	0.71	2.09	0.18	0.92	0.03
80							19.98	43.19	14.50	19.81	8.68	5.68	6.04	2.36	3.88	0.80	2.22	0.21	0.98	0.03
85									15.41	22.16	9.22	6.36	6.42	2.63	4.12	0.90	2.36	0.23	1.04	0.03
90									16.32	24.64	9.76	7.07	6.80	2.93	4.36	1.00	2.50	0.26	1.10	0.04
95									17.22	27.23	10.30	7.81	7.18	3.24	4.60	1.10	2.64	0.29	1.16	0.04
100									18.13	29.95	10.85	8.59	7.56	3.57	4.85	1.21	2.78	0.31	1.22	0.04
110									19.94	35.73	11.93	10.25	8.31	4.25	5.33	1.45	3.06	0.38	1.35	0.05
120									13.02	12.04	9.07	5.00	5.82	1.70	3.34	0.44	1.47	0.06		
130									14.10	13.96	9.82	5.60	6.30	1.97	3.62	0.51	1.59	0.07		
140									15.19	16.02	10.58	6.65	6.79	2.27	3.90	0.59	1.72	0.08		
150									16.27	18.20	11.34	7.56	7.27	2.57	4.18	0.67	1.84	0.09		
160									17.36	20.51	12.09	8.51	7.76	2.89	4.45	0.75	1.96	0.10		
170									18.44	22.95	12.85	9.53	8.24	3.24	4.73	0.84	2.08	0.11		
180									19.53	25.51	13.60	10.59	8.73	3.60	5.01	0.93	2.21	0.13		
190											14.36	11.71	9.21	3.98	5.29	1.03	2.33	0.14		
200											15.12	12.87	9.70	4.37	5.57	1.14	2.45	0.16		
225											17.01	16.01	10.91	5.44	6.27	1.41	2.76	0.19		
250											18.90	19.46	12.12	6.61	6.96	1.72	3.07	0.23		
275													13.34	7.89	7.66	2.05	3.38	0.28		
300													14.55	9.27	8.36	2.41	3.68	0.33		
325													15.76	10.75	9.05	2.79	3.99	0.38		
350													16.97	12.33	9.75	3.20	4.30	0.44		
375													18.19	14.01	10.45	3.64	4.60	0.50		
400													19.40	15.79	11.14	4.10	4.91	0.56		
425															11.84	4.59	5.22	0.63		
450															12.54	5.10	5.53	0.70		
475															13.23	5.64	5.83	0.77		
500															13.93	6.20	6.14	0.85		
550															15.32	7.40	6.76	1.01		
600															16.72	8.69	7.37	1.19		

Note: Shaded areas of the chart indicate velocities over 5 feet per second (FPS). Use with caution.

Velocity of flow rate values are computed from the general equation $V = .408 Q/d^2$

Friction pressure loss values are computed from the equation $[hf = 0.2083 (100/C) 1.852 Q^{1.852}/d^{4.868}] \times 4.33$ for psi loss per 100' of pipe.

CHARTS

PVC Class 125 IPS Plastic Pipe

SIZES: 1" – 6" **FLOW:** 1 – 600 GPM **PSI LOSS:** Per 100' of tube (PSI/100 FT) **C = 150 (1120, 1220) SDR 32.5**

SIZE	1"		1 1/4"		1 1/2"		2"		2 1/2"		3"		4"		6"	
OD	1.315		1.660		1.900		2.375		2.875		3.500		4.500		6.625	
ID	1.211		1.548		1.784		2.229		2.699		3.284		4.224		6.217	
WALL THK.	0.052		0.056		0.058		0.073		0.088		0.108		0.138		0.204	
FLOW G. P. M.	Velocity FPS	psi Loss	Velocity FPS	psi Loss	Velocity FPS	psi Loss	Velocity FPS	psi Loss	Velocity FPS	psi Loss	Velocity FPS	psi Loss	Velocity FPS	psi Loss	Velocity FPS	psi Loss
1	0.27	0.02	0.17	0.01	0.12	0.00										
2	0.55	0.06	0.34	0.02	0.25	0.01	0.16	0.00								
3	0.83	0.13	0.51	0.04	0.38	0.02	0.24	0.01								
4	1.11	0.22	0.68	0.07	0.51	0.03	0.32	0.01	0.22	0.00						
5	1.39	0.33	0.85	0.10	0.64	0.05	0.41	0.02	0.28	0.01						
6	1.66	0.46	1.02	0.14	0.76	0.07	0.49	0.02	0.33	0.01						
7	1.94	0.62	1.19	0.19	0.89	0.09	0.57	0.03	0.39	0.01	0.26	0.00				
8	2.22	0.79	1.36	0.24	1.02	0.12	0.65	0.04	0.44	0.02	0.30	0.01				
9	2.50	0.98	1.53	0.30	1.15	0.15	0.73	0.05	0.50	0.02	0.34	0.01				
10	2.78	1.19	1.70	0.36	1.28	0.18	0.82	0.06	0.56	0.02	0.37	0.01				
11	3.06	1.42	1.87	0.43	1.41	0.22	0.90	0.07	0.61	0.03	0.41	0.01				
12	3.33	1.67	2.04	0.51	1.53	0.25	0.98	0.09	0.67	0.03	0.45	0.01	0.27	0.00		
14	3.89	2.22	2.38	0.67	1.79	0.34	1.14	0.11	0.78	0.05	0.52	0.02	0.32	0.01		
16	4.45	2.85	2.72	0.86	2.05	0.43	1.31	0.15	0.89	0.06	0.60	0.02	0.36	0.01		
18	5.00	3.54	3.06	1.07	2.30	0.54	1.47	0.18	1.00	0.07	0.68	0.03	0.41	0.01		
20	5.56	4.31	3.40	1.30	2.56	0.65	1.64	0.22	1.12	0.09	0.75	0.03	0.45	0.01		
22	6.12	5.14	3.74	1.56	2.82	0.78	1.80	0.26	1.23	0.10	0.83	0.04	0.50	0.01		
24	6.67	6.04	4.08	1.83	3.07	0.92	1.97	0.31	1.34	0.12	0.90	0.05	0.54	0.01		
26	7.23	7.00	4.42	2.12	3.33	1.06	2.13	0.36	1.45	0.14	0.98	0.05	0.59	0.02		
28	7.78	8.03	4.76	2.43	3.58	1.22	2.29	0.41	1.56	0.16	1.05	0.06	0.644	0.02		
30	8.34	9.13	5.10	2.76	3.84	1.39	2.46	0.47	1.68	0.18	1.13	0.07	0.68	0.02		
35	9.73	12.14	5.95	3.68	4.48	1.84	2.87	0.62	1.96	0.25	1.32	0.09	0.80	0.03	0.36	0.00
40	11.12	15.55	6.81	4.71	5.12	2.36	3.28	0.80	2.24	0.31	1.51	0.12	0.91	0.04	0.42	0.01
45	12.51	19.34	7.66	5.86	5.76	2.94	3.69	0.99	2.52	0.39	1.70	0.15	1.02	0.04	0.47	0.01
50	13.91	23.50	8.51	7.12	6.40	3.57	4.10	1.21	2.80	0.48	1.89	0.18	1.14	0.05	0.52	0.01
55	15.30	28.04	9.36	8.49	7.05	4.26	4.51	1.44	3.08	0.57	2.08	0.22	1.25	0.06	0.58	0.01
60	16.69	32.94	10.21	9.98	7.69	5.00	4.92	1.69	3.36	0.67	2.26	0.26	1.37	0.085	0.63	0.01
65	18.08	38.21	11.06	11.57	8.33	5.80	5.33	1.96	3.64	0.77	2.45	0.30	1.48	0.09	0.68	0.01
70	19.47	43.83	11.91	13.27	8.97	6.65	5.74	2.25	3.92	0.89	2.64	0.34	1.60	0.10	0.73	0.02
75			12.76	15.08	9.61	7.56	6.15	2.56	4.20	1.01	2.83	0.39	1.71	0.11	0.79	0.02
80			13.62	17.00	10.25	8.52	6.56	2.88	4.48	1.14	3.02	0.44	1.82	0.13	0.84	0.02
85			14.47	19.02	10.89	9.53	6.98	3.23	4.76	1.27	3.21	0.49	1.94	0.14	0.89	0.02
90			15.32	21.14	11.53	10.60	7.39	3.59	5.04	1.41	3.40	0.54	2.05	0.16	0.95	0.02
95			16.17	23.37	12.17	11.71	7.80	3.96	5.32	1.56	3.59	0.60	2.17	0.18	1.00	0.03
100			17.02	25.69	12.81	12.88	8.21	4.36	5.60	1.72	3.78	0.66	2.28	0.19	1.05	0.03
110			18.72	3.65	14.10	15.37	9.03	5.20	6.16	2.05	4.16	0.79	2.51	0.23	1.16	0.04
120					15.38	18.06	9.85	6.11	6.72	2.41	4.53	0.93	2.74	0.27	1.26	0.04
130					16.66	20.94	10.67	7.09	7.28	2.79	4.91	1.08	2.97	0.32	1.37	0.05
140					17.94	24.02	11.49	8.13	7.84	3.20	5.29	1.23	3.20	0.36	1.47	0.06
150					19.22	27.30	12.31	9.24	8.40	3.64	5.67	1.40	3.43	0.41	1.58	0.06
160							13.13	10.41	8.96	4.10	6.05	1.58	3.65	0.46	1.68	0.07
170							13.96	11.65	9.52	4.59	6.43	1.77	3.88	0.52	1.79	0.08
180							14.78	12.95	10.08	5.10	6.80	1.96	4.11	0.58	1.90	0.09
190							15.60	14.31	10.64	5.64	7.18	2.17	4.34	0.64	2.00	0.10
200							16.42	15.74	11.20	6.20	7.56	2.39	4.57	0.70	2.11	0.11
225							18.47	19.57	12.60	7.72	8.51	2.97	5.14	0.87	2.37	0.13
250									14.00	9.38	9.45	3.61	5.71	1.06	2.63	0.16
275									15.40	11.19	10.40	4.31	6.28	1.27	2.90	0.19
300									16.80	13.15	11.34	5.06	6.86	1.49	3.16	0.23
325									18.20	15.25	12.29	5.87	7.43	1.72	3.43	0.26
350									19.60	17.49	13.24	6.73	8.00	1.98	3.69	0.30
375											14.18	7.65	8.57	2.25	3.95	0.34
400											15.13	8.62	9.14	2.53	4.22	0.39
425											16.07	9.65	9.71	2.83	4.48	0.43
450											17.02	10.72	10.29	3.15	4.75	0.48
475											17.96	11.85	10.86	3.48	5.01	0.53
500											18.91	13.03	11.43	3.83	5.27	0.58
550													12.57	4.57	5.80	0.70
600													13.72	5.37	6.33	0.82

Note: Shaded areas of the chart indicate velocities over 5 feet per second (FPS). Use with caution.

CHARTS

PVC Class 160 IPS Plastic Pipe

SIZES: 1" – 6" **FLOW:** 1 – 600 GPM **PSI LOSS:** Per 100' of tube (PSI/100 FT) **C = 150** (1120, 1220) SDR 26

SIZE	1"		1 1/4"		1 1/2"		2"		2 1/2"		3"		4"		6"	
OD	1.315	1.660	1.900	2.375	2.875	3.500	4.500	6.625								
ID	1.195	1.532	1.754	2.193	2.655	3.230	4.154	6.115								
WALL THK.	0.060	0.064	0.073	0.091	0.110	0.135	0.173	0.225								
FLOW G. P. M.	Velocity FPS	psi Loss	Velocity FPS	psi Loss	Velocity FPS	psi Loss	Velocity FPS	psi Loss	Velocity FPS	psi Loss	Velocity FPS	psi Loss	Velocity FPS	psi Loss	Velocity FPS	psi Loss
1	0.28	0.02	0.17	0.01	0.13	0.00										
2	0.57	0.06	0.34	0.02	0.26	0.01	0.16	0.00								
3	0.85	0.14	0.52	0.04	0.39	0.02	0.25	0.01								
4	1.14	0.23	0.69	0.07	0.53	0.04	0.33	0.01	0.23	0.00						
5	1.42	0.35	0.86	0.11	0.66	0.05	0.42	0.02	0.28	0.01						
6	1.71	0.49	1.04	0.15	0.79	0.08	0.50	0.03	0.34	0.01	0.20	0.00				
7	1.99	0.66	1.21	0.20	0.92	0.10	0.59	0.03	0.40	0.01	0.27	0.01				
8	2.28	0.84	1.39	0.25	1.06	0.13	0.67	0.04	0.46	0.02	0.31	0.01				
9	2.57	1.05	1.56	0.31	1.19	0.16	0.76	0.05	0.52	0.02	0.35	0.01				
10	2.85	1.27	1.73	0.38	1.32	0.20	0.84	0.07	0.57	0.03	0.39	0.01				
11	3.14	1.52	1.91	0.45	1.45	0.23	0.93	0.08	0.63	0.03	0.43	0.01				
12	3.42	1.78	2.085	0.53	1.59	0.28	1.01	0.09	0.69	0.04	0.46	0.01	0.28	0.00		
14	3.99	2.37	2.43	0.71	1.85	0.37	1.18	0.12	0.81	0.05	0.54	0.02	0.33	0.01		
16	4.57	3.04	2.78	0.91	2.12	0.47	1.35	0.16	0.92	0.06	0.62	0.02	0.37	0.01		
18	5.14	3.78	3.12	1.13	2.38	0.58	1.52	0.20	1.04	0.08	0.70	0.03	0.42	0.01		
20	5.71	4.59	3.47	1.37	2.65	0.71	1.69	0.24	1.15	0.09	0.78	0.04	0.47	0.01		
22	6.28	5.48	3.82	1.64	2.91	0.85	1.86	0.29	1.27	0.11	0.86	0.04	0.52	0.01		
24	6.85	6.44	4.17	1.92	3.18	1.00	2.03	0.34	1.38	0.13	0.93	0.05	0.56	0.02		
26	7.42	7.47	4.51	2.23	3.44	1.15	2.20	0.39	1.50	0.15	1.01	0.06	0.61	0.02		
28	7.99	8.57	4.86	2.56	3.71	1.32	2.37	0.45	1.62	0.18	1.09	0.07	0.66	0.02		
30	8.57	9.74	5.21	2.91	3.97	1.50	2.54	0.51	1.73	0.20	1.17	0.08	0.70	0.02		
35	9.99	12.95	6.08	3.87	4.64	2.00	2.96	0.68	2.02	0.27	1.36	0.10	0.82	0.03	0.38	0.00
40	11.42	16.59	6.95	4.95	5.30	2.56	3.39	0.86	2.31	0.34	1.56	0.13	0.94	0.04	0.43	0.01
45	12.85	20.63	7.82	6.16	5.96	3.19	3.81	1.08	2.60	0.42	1.75	0.16	1.06	0.05	0.49	0.01
50	14.28	25.07	8.69	7.49	6.63	3.88	4.24	1.31	2.89	0.52	1.95	0.20	1.18	0.06	0.54	0.01
55	15.71	29.91	9.56	8.93	7.29	4.62	4.66	1.56	3.18	0.62	2.15	0.24	1.30	0.07	0.60	0.01
60	17.14	35.14	10.43	10.49	7.95	5.43	5.09	1.83	3.47	0.72	2.34	0.28	1.41	0.08	0.65	0.01
65	18.57	40.67	11.29	12.17	8.62	6.30	5.51	2.12	3.76	0.84	2.54	0.32	1.53	0.09	0.70	0.01
70	19.99	46.76	12.16	13.96	9.28	7.23	5.93	2.44	4.05	0.96	2.73	0.37	1.65	0.11	0.76	0.02
75			13.03	15.86	9.94	8.21	6.36	2.77	4.34	1.09	2.93	0.42	1.77	0.12	0.81	0.02
80			13.90	17.88	10.60	9.25	6.78	3.12	4.63	1.23	3.12	0.47	1.89	0.14	0.87	0.02
85			14.77	20.00	11.27	10.35	7.21	3.49	4.91	1.38	3.32	0.53	2.00	0.16	0.92	0.02
90			15.64	22.23	11.93	11.51	7.63	3.88	5.20	1.53	3.51	0.59	2.12	0.17	0.98	0.03
95			16.51	24.58	12.59	12.72	8.05	4.29	5.49	1.69	3.71	0.65	2.24	0.19	1.03	0.03
100			17.38	27.03	13.26	13.99	8.48	4.72	5.78	1.86	3.91	0.72	2.36	0.21	1.09	0.03
110			19.12	32.24	14.58	16.69	9.33	5.63	6.36	2.22	4.30	0.86	2.60	0.25	1.20	0.04
120					15.91	19.61	10.18	6.61	6.94	2.61	4.69	1.01	2.83	0.30	1.30	0.05
130					17.24	22.74	11.02	7.67	7.52	3.03	5.08	1.17	3.07	0.34	1.41	0.05
140					18.56	26.09	11.87	8.80	8.10	3.47	5.47	1.34	3.31	0.39	1.52	0.06
150					19.89	29.64	12.72	10.00	8.68	3.94	5.86	1.52	3.54	0.45	1.63	0.07
160							13.57	11.27	9.26	4.45	6.25	1.71	3.78	0.50	1.74	0.08
170							14.42	12.61	9.83	4.97	6.64	1.92	4.01	0.56	1.85	0.09
180							15.27	14.02	10.41	5.53	7.03	2.13	4.25	0.63	1.96	0.10
190							16.11	15.49	10.99	6.11	7.43	2.35	4.49	0.69	2.07	0.11
200							16.96	17.03	11.57	6.72	7.82	2.59	4.72	0.76	2.18	0.12
225							19.08	21.19	13.02	8.36	8.79	3.22	5.31	0.95	2.45	0.14
250									14.47	10.16	9.77	3.91	5.91	1.15	2.72	0.18
275									15.91	12.12	10.75	4.67	6.50	1.37	3.00	0.21
300									17.36	14.24	11.73	5.49	7.09	1.61	3.27	0.25
325									18.81	16.51	12.70	6.36	7.68	1.87	3.54	0.29
350											13.68	7.30	8.27	2.15	3.81	0.33
375											14.66	8.29	8.86	2.44	4.09	0.37
400											15.64	9.35	9.45	2.75	4.36	0.42
425											16.62	10.46	10.04	3.07	4.63	0.47
450											17.59	11.62	10.63	3.42	4.90	0.52
475											18.57	12.85	11.23	3.78	5.18	0.58
500											19.55	14.13	11.82	4.15	5.45	0.63
550													13.00	4.96	6.00	0.76
600													14.18	5.82	6.54	0.89

Note: Shaded areas of the chart indicate velocities over 5 feet per second (FPS). Use with caution.

CHARTS

PVC Class 200 IPS Plastic Pipe

SIZES: 3/4" – 6" **FLOW:** 1 – 600 GPM **PSI LOSS:** Per 100' of pipe (PSI/100 FT) **C = 150 (1120, 1220) SDR 21**

SIZE	3/4"		1"		1 1/4"		1 1/2"		2"		2 1/2"		3"		4"		6"	
OD	1.050		1.315		1.660		1.900		2.375		2.875		3.500		4.500		6.625	
ID	0.930		1.189		1.502		1.720		2.149		2.601		3.166		4.072		5.993	
WALL THK.	0.060		0.063		0.079		0.090		0.113		0.137		0.167		0.214		0.316	
FLOW G. P. M.	Velocity FPS	psi Loss	Velocity FPS	psi Loss	Velocity FPS	psi Loss	Velocity FPS	psi Loss	Velocity FPS	psi Loss	Velocity FPS	psi Loss	Velocity FPS	psi Loss	Velocity FPS	psi Loss	Velocity FPS	psi Loss
1	0.47	0.06	0.28	0.02	0.18	0.01	0.13	0.00										
2	0.94	0.22	0.57	0.07	0.36	0.02	0.27	0.01	0.17	0.00								
3	1.42	0.46	0.86	0.14	0.54	0.04	0.41	0.02	0.26	0.01	0.18	0.00						
4	1.89	0.79	1.15	0.24	0.72	0.08	0.55	0.04	0.35	0.01	0.24	0.01						
5	2.36	1.20	1.44	0.36	0.90	0.12	0.68	0.06	0.44	0.02	0.30	0.01						
6	2.83	1.68	1.73	0.51	1.08	0.16	0.82	0.08	0.53	0.03	0.36	0.01	0.24	0.00				
7	3.30	2.23	2.02	0.67	1.26	0.22	0.96	0.11	0.61	0.04	0.42	0.01	0.28	0.01				
8	3.77	2.85	2.30	0.86	1.44	0.28	1.10	0.14	0.70	0.05	0.48	0.02	0.32	0.01				
9	4.25	3.55	2.59	1.07	1.62	0.34	1.24	0.18	0.79	0.06	0.54	0.02	0.36	0.01				
10	4.72	4.31	2.88	1.30	1.80	0.42	1.37	0.22	0.88	0.07	0.60	0.03	0.40	0.01				
11	5.19	5.15	3.17	1.56	1.98	0.50	1.51	0.26	0.97	0.09	0.66	0.03	0.44	0.01				
12	5.66	6.05	3.46	1.83	2.17	0.59	1.65	0.30	1.06	0.10	0.72	0.04	0.48	0.02	0.29	0.00		
14	6.60	8.05	4.04	2.43	2.53	0.78	1.93	0.40	1.23	0.14	0.84	0.05	0.56	0.02	0.34	0.01		
16	7.55	10.30	4.61	3.11	2.89	1.00	2.20	0.52	1.41	0.17	0.96	0.07	0.65	0.03	0.39	0.01		
18	8.49	12.81	5.19	3.87	3.25	1.24	2.48	0.64	1.59	0.22	1.08	0.09	0.73	0.03	0.44	0.01		
20	9.43	15.58	5.77	4.71	3.61	1.51	2.75	0.78	1.76	0.26	1.20	0.10	0.81	0.04	0.49	0.01		
22	10.38	18.58	6.34	5.62	3.97	1.80	3.03	0.93	1.94	0.32	1.32	0.12	0.89	0.05	0.54	0.01		
24	11.32	21.83	6.92	6.60	4.34	2.12	3.30	1.09	2.12	0.37	1.44	0.15	0.97	0.06	0.59	0.02		
26	12.27	25.32	7.50	7.65	4.70	2.46	3.58	1.27	2.29	0.43	1.56	0.17	1.05	0.07	0.63	0.02		
28	13.21	29.04	8.08	8.78	5.06	2.82	3.86	1.46	2.47	0.49	1.68	0.19	1.13	0.07	0.68	0.02		
30	14.15	33.00	8.65	9.98	5.42	3.20	4.13	1.66	2.65	0.56	1.80	0.22	1.22	0.09	0.73	0.02	0.34	0.00
35	16.51	43.91	10.10	13.27	6.32	4.26	4.82	2.20	3.09	0.75	2.11	0.29	1.42	0.11	0.86	0.03	0.39	0.01
40	18.87	56.23	11.54	17.00	7.23	5.45	5.51	2.82	3.53	0.95	2.41	0.38	1.62	0.14	0.98	0.04	0.45	0.01
45			12.98	21.14	8.13	6.78	6.20	3.51	3.97	1.19	2.71	0.47	1.83	0.18	1.10	0.05	0.51	0.01
50			14.42	25.70	9.04	8.24	6.89	4.26	4.41	1.44	3.01	0.57	2.03	0.22	1.23	0.06	0.56	0.01
55			15.87	30.66	9.94	9.83	7.58	5.09	4.85	1.72	3.31	0.68	2.23	0.26	1.35	0.08	0.62	0.01
60			17.31	36.02	10.85	11.55	8.27	5.97	5.30	2.02	3.61	0.80	2.44	0.31	1.47	0.09	0.68	0.01
65			18.75	41.77	11.75	13.40	8.96	6.93	5.74	2.35	3.92	0.93	2.64	0.36	1.59	0.10	0.73	0.02
70					12.65	15.37	9.65	7.95	6.18	2.69	4.22	1.06	2.84	0.41	1.72	0.12	0.79	0.02
75					13.56	17.47	10.34	9.03	6.62	3.06	4.52	1.21	3.05	0.46	1.84	0.14	0.85	0.02
80					14.46	19.68	11.03	10.18	7.06	3.44	4.82	1.36	3.25	0.52	1.96	0.15	0.90	0.02
85					15.37	22.02	11.72	11.39	7.50	3.85	5.12	1.52	3.45	0.59	2.09	0.17	0.96	0.03
90					16.27	24.48	12.41	12.66	7.95	4.28	5.42	1.69	3.66	0.65	2.21	0.19	1.02	0.03
95					17.18	27.06	13.10	13.99	8.39	4.74	5.72	1.87	3.86	0.72	2.33	0.21	1.07	0.03
100					18.08	29.76	13.79	15.39	8.83	5.21	6.03	2.06	4.07	0.79	2.46	0.23	1.13	0.04
110					19.89	35.50	15.17	18.36	9.71	6.21	6.63	2.45	4.47	0.94	2.70	0.28	1.24	0.04
120							16.54	21.57	10.60	7.30	7.23	2.88	4.88	1.11	2.95	0.33	1.36	0.05
130							17.92	25.02	11.48	8.47	7.84	3.34	5.29	1.29	3.19	0.38	1.47	0.06
140							19.30	28.70	12.36	9.71	8.44	3.84	5.69	1.47	3.44	0.43	1.59	0.07
150									13.25	11.04	9.04	4.36	6.10	1.68	3.69	0.49	1.70	0.08
160									14.13	12.44	9.64	4.91	6.51	1.89	3.93	0.55	1.81	0.08
170									15.01	13.91	10.25	5.50	6.91	2.11	4.18	0.62	1.93	0.09
180									15.90	15.47	10.85	6.11	7.32	2.35	4.42	0.69	2.04	0.11
190									16.78	17.10	11.45	6.75	7.73	2.60	4.67	0.76	2.15	0.12
200									17.66	18.80	12.06	7.43	8.14	2.85	4.92	0.84	2.27	0.13
225									19.87	23.38	13.56	9.24	9.15	3.55	5.53	1.04	2.55	0.16
250											15.07	11.23	10.17	4.31	6.15	1.27	2.83	0.19
275											16.58	13.39	11.19	5.15	6.76	1.51	3.12	0.23
300											18.09	15.74	12.21	6.05	7.38	1.78	3.40	0.27
325											19.60	18.25	13.22	7.01	7.99	2.06	3.69	0.31
350													14.24	8.05	8.61	2.36	3.97	0.36
375													15.26	9.14	9.22	2.69	4.25	0.41
400													16.28	10.30	9.84	3.03	4.54	0.46
425													17.29	11.53	10.45	3.396	4.82	0.52
450													18.31	12.81	11.07	3.77	5.11	0.57
475													19.33	14.16	11.68	4.16	5.39	0.63
500															12.30	4.58	5.67	0.70
550															13.53	5.46	6.24	0.83
600															14.76	6.42	6.81	0.98

Note: Shaded areas of the chart indicate velocities over 5 feet per second (FPS). Use with caution.

CHARTS

PVC Class 315 IPS Plastic Pipe

SIZES: 1/2" – 6" **FLOW:** 1 – 600 GPM **PSI LOSS:** Per 100' of pipe (PSI/100 FT) **C = 150** (1120, 1220) SDR 13.5

SIZE	1/2"		3/4"		1"		1 1/4"		1 1/2"		2"		2 1/2"		3"		4"		6"	
OD	0.840		1.050		1.315		1.660		1.900		2.375		2.875		3.500		4.500		6.625	
ID	0.716		0.894		1.121		1.414		1.618		2.023		2.449		2.982		3.834		5.643	
WALL THK.	0.062		0.078		0.097		0.123		0.141		0.176		0.213		0.259		0.333		0.491	
FLOW G. P. M.	Velocity FPS	psi Loss	Velocity FPS	psi Loss	Velocity FPS	psi Loss	Velocity FPS	psi Loss	Velocity FPS	psi Loss	Velocity FPS	psi Loss	Velocity FPS	psi Loss	Velocity FPS	psi Loss	Velocity FPS	psi Loss	Velocity FPS	psi Loss
1	0.79	0.22	0.51	0.07	0.32	0.02	0.20	0.01	0.15	0.00										
2	1.59	0.78	1.02	0.27	0.64	0.09	0.40	0.03	0.31	0.01	0.19	0.00								
3	2.38	1.65	1.53	0.56	0.97	0.19	0.61	0.06	0.46	0.03	0.29	0.01	0.20	0.00						
4	3.18	2.82	2.04	0.96	1.29	0.32	0.81	0.10	0.62	0.05	0.39	0.02	0.27	0.01						
5	3.97	4.26	2.55	1.45	1.62	0.48	1.02	0.16	0.77	0.08	0.49	0.03	0.34	0.01	0.22	0.00				
6	4.77	5.97	3.06	2.03	1.94	0.67	1.22	0.22	0.93	0.11	0.59	0.04	0.40	0.02	0.27	0.01				
7	5.57	7.95	3.57	2.70	2.27	0.90	1.42	0.29	1.09	0.15	0.69	0.05	0.47	0.02	0.32	0.01				
8	6.36	10.18	4.08	3.45	2.59	1.15	1.63	0.37	1.24	0.19	0.79	0.06	0.54	0.03	0.36	0.01				
9	7.16	12.66	4.59	4.30	2.92	1.43	1.83	0.46	1.40	0.24	0.89	0.08	0.61	0.03	0.41	0.01				
10	7.95	15.38	5.10	5.22	3.24	1.74	2.04	0.56	1.55	0.29	0.99	0.10	0.68	0.04	0.45	0.01	0.27	0.00		
11	8.75	18.35	5.61	6.23	3.57	2.07	2.24	0.67	1.71	0.35	1.09	0.12	0.74	0.05	0.50	0.02	0.30	0.01		
12	9.55	21.56	6.12	7.32	3.89	2.43	2.44	0.79	1.87	0.41	1.19	0.14	0.81	0.05	0.55	0.02	0.33	0.01		
14	11.14	28.69	7.14	9.74	4.54	3.24	2.85	1.05	2.18	0.54	1.39	0.18	0.95	0.07	0.64	0.03	0.38	0.01		
16	12.73	36.74	8.16	12.47	5.19	4.15	3.26	1.34	2.49	0.70	1.59	0.23	1.08	0.09	0.73	0.04	0.44	0.01		
18	14.32	45.69	9.18	15.51	5.84	5.16	3.67	1.67	2.80	0.87	1.79	0.29	1.22	0.12	0.82	0.04	0.49	0.01		
20	15.91	55.54	10.20	18.86	6.49	6.27	4.08	2.03	3.11	1.05	1.99	0.35	1.36	0.14	0.91	0.05	0.55	0.02		
22	17.50	66.26	11.23	22.50	7.14	7.48	4.48	2.42	3.42	1.25	2.19	0.42	1.49	0.17	1.00	0.06	0.61	0.02		
24	19.10	77.84	12.25	26.43	7.79	8.79	4.89	2.84	3.74	1.47	2.39	0.50	1.63	0.20	1.10	0.08	0.66	0.02		
26			13.27	30.65	8.44	10.19	5.30	3.29	4.05	1.71	2.59	0.58	1.76	0.23	1.19	0.09	0.72	0.03		
28			14.29	35.16	9.09	11.69	5.71	3.78	4.36	1.96	2.79	0.66	1.90	0.26	1.28	0.10	0.77	0.03	0.35	0.00
30			15.31	39.95	9.74	13.29	6.12	4.29	4.67	2.23	2.99	0.75	2.04	0.30	1.37	0.11	0.83	0.03	0.38	0.01
35			17.86	53.15	11.36	17.68	7.14	5.71	5.45	2.96	3.48	1.00	2.38	0.39	1.60	0.15	0.97	0.04	0.44	0.01
40					12.98	22.64	8.16	7.31	6.23	3.80	3.98	1.28	2.72	0.51	1.83	0.19	1.11	0.06	0.51	0.01
45					14.61	28.15	9.18	9.10	7.01	4.72	4.48	1.59	3.06	0.63	2.06	0.24	1.24	0.07	0.57	0.01
50					16.23	34.22	10.20	11.06	7.79	5.74	4.98	1.94	3.40	0.76	2.29	0.29	1.38	0.09	0.64	0.01
55					17.85	40.83	11.22	13.19	8.57	6.85	5.48	2.31	3.74	0.91	2.52	0.35	1.52	0.10	0.70	0.02
60					19.48	47.97	12.24	15.50	9.35	8.04	5.98	2.71	4.08	1.07	2.75	0.41	1.66	0.12	0.76	0.02
65							13.26	17.97	10.13	9.33	6.48	3.15	4.42	1.24	2.98	0.48	1.80	0.14	0.83	0.02
70							14.28	20.62	10.90	10.70	6.97	3.61	4.76	1.42	3.21	0.55	1.94	0.16	0.89	0.02
75							15.30	23.43	11.68	12.16	7.47	4.10	5.10	1.62	3.44	0.62	2.08	0.18	0.96	0.03
80							16.32	26.40	12.46	13.71	7.97	4.62	5.44	1.82	3.67	0.70	2.22	0.21	1.02	0.03
85							17.34	29.54	13.24	15.33	8.47	5.17	5.78	2.04	3.89	0.78	2.35	0.23	1.08	0.04
90							18.36	32.84	14.02	17.05	8.97	5.75	6.12	2.27	4.12	0.87	2.49	0.26	1.15	0.04
95							19.38	36.30	14.80	18.84	9.47	6.35	6.46	2.51	4.35	0.96	2.63	0.28	1.21	0.04
100									15.58	20.72	9.96	6.99	6.80	2.76	4.58	1.06	2.77	0.31	1.28	0.05
110									17.14	24.72	10.96	8.34	7.48	3.29	5.04	1.26	3.05	0.37	1.40	0.06
120									18.70	29.04	11.96	9.79	8.16	3.87	5.50	1.48	3.33	0.44	1.53	0.07
130											12.96	11.36	8.84	4.48	5.96	1.72	3.60	0.51	1.66	0.08
140											13.95	13.03	9.52	5.14	6.42	1.97	3.88	0.58	1.79	0.09
150											14.95	14.81	10.20	5.84	6.88	2.24	4.16	0.66	1.92	0.10
160											15.95	16.69	10.88	6.59	7.34	2.53	4.44	0.74	2.04	0.11
170											16.94	18.67	11.56	7.37	7.79	2.83	4.71	0.83	2.17	0.13
180											17.94	20.75	12.24	8.19	8.25	3.14	4.99	0.93	2.30	0.14
190											18.94	22.94	12.92	9.05	8.71	3.47	5.27	1.02	2.43	0.16
200											19.93	25.23	13.60	9.95	9.17	3.82	5.55	1.12	2.56	0.17
225													15.30	12.38	10.32	4.75	6.24	1.40	2.88	0.21
250													17.00	15.05	11.47	5.77	6.93	1.70	3.20	0.26
275													18.70	17.95	12.61	6.89	7.63	2.03	3.52	0.31
300															13.76	8.09	8.32	2.38	3.84	0.36
325															14.91	9.39	9.02	2.76	4.16	0.42
350															16.05	10.77	9.71	3.17	4.48	0.48
375															17.20	12.23	10.40	3.60	4.80	0.55
400															18.35	13.79	11.10	4.06	5.12	0.62
425															19.49	15.42	11.79	4.54	5.44	0.69
450																	12.49	5.05	5.76	0.77
475																	13.18	5.58	6.08	0.85
500																	13.87	6.14	6.40	0.94
550																	15.26	7.32	7.04	1.12
600																	16.65	8.60	7.68	1.31

Note: Shaded areas of the chart indicate velocities over 5 feet per second (FPS). Use with caution.

CHARTS

Type K Copper Water Tube

SIZES: 1/2" – 3" **FLOW:** 1 – 600 GPM **PSI LOSS:** Per 100' of tube (PSI/100 FT) **C = 140**

SIZE	1/2"		5/8"		3/4"		1"		1 1/4"		1 1/2"		2"		2 1/2"		3"	
OD	0.625		0.750		0.875		1.125		1.375		1.625		2.125		2.625		3.125	
ID	0.527		0.652		0.745		0.995		1.245		1.481		1.959		2.435		2.907	
WALL THK.	0.049		0.049		0.065		0.065		0.065		0.072		0.083		0.095		0.109	
FLOW G. P. M.	Velocity FPS	psi Loss	Velocity FPS	psi Loss	Velocity FPS	psi Loss	Velocity FPS	psi Loss	Velocity FPS	psi Loss	Velocity FPS	psi Loss	Velocity FPS	psi Loss	Velocity FPS	psi Loss	Velocity FPS	psi Loss
1	1.45	1.09	0.95	0.39	0.73	0.20	0.41	0.05	0.26	0.02	0.18	0.01	0.10	0.00				
2	2.93	3.94	1.91	1.40	1.47	0.73	0.82	0.18	0.52	0.06	0.37	0.03	0.21	0.01				
3	4.40	8.35	2.87	2.974	2.20	1.55	1.23	0.38	0.78	0.13	0.55	0.05	0.31	0.01	0.20	0.00		
4	5.87	14.23	3.83	5.05	2.94	2.64	1.64	0.65	1.05	0.22	0.74	0.09	0.42	0.02	0.27	0.01	0.19	0.00
5	7.34	21.51	4.79	7.64	3.67	3.99	2.06	0.98	1.31	0.33	0.93	0.14	0.53	0.04	0.34	0.01	0.24	0.01
6	8.81	30.15	5.75	10.70	4.41	5.60	2.47	1.37	1.57	0.46	1.11	0.20	0.63	0.05	0.41	0.02	0.28	0.01
7	10.28	40.11	6.71	14.24	5.14	7.44	2.88	1.82	1.84	0.61	1.30	0.26	0.74	0.07	0.48	0.02	0.33	0.01
8	11.75	51.37	7.67	18.24	5.88	9.53	3.29	2.33	2.10	0.78	1.48	0.34	0.85	0.09	0.55	0.03	0.38	0.01
9	13.22	63.89	8.63	22.68	6.61	11.86	3.70	2.90	2.36	0.97	1.67	0.42	0.95	0.11	0.61	0.04	0.43	0.02
10	14.69	77.66	9.59	27.57	7.35	14.41	4.12	3.53	2.63	1.18	1.86	0.51	1.06	0.13	0.68	0.05	0.48	0.02
11	16.15	92.65	10.55	32.89	8.08	17.19	4.53	4.21	2.89	1.41	2.04	0.61	1.16	0.16	0.75	0.05	0.53	0.02
12	17.62	108.85	11.51	38.64	8.82	20.20	4.94	4.94	3.15	1.66	2.23	0.71	1.27	0.18	0.82	0.06	0.57	0.03
14			13.43	51.41	10.29	26.87	5.76	6.57	3.68	2.21	2.60	0.95	1.48	0.24	0.95	0.08	0.67	0.04
16			15.35	65.83	11.76	34.41	6.59	8.42	4.21	2.83	2.97	1.22	1.70	0.31	1.10	0.11	0.77	0.05
18			17.27	81.88	13.23	42.80	7.41	10.47	4.73	3.52	3.34	1.51	1.91	0.39	1.23	0.13	0.86	0.06
20			19.19	99.53	14.70	52.02	8.24	12.73	5.26	4.28	3.72	1.84	2.12	0.47	1.37	0.16	0.96	0.07
22					16.17	62.06	9.06	15.18	5.79	5.10	4.09	2.19	2.33	0.56	1.51	0.20	1.06	0.08
24					17.64	72.92	9.89	17.84	6.31	5.99	4.46	2.58	2.55	0.66	1.65	0.23	1.15	0.10
26					19.11	84.57	10.71	20.69	6.84	6.95	4.83	2.99	2.76	0.77	1.78	0.27	1.25	0.11
28							11.53	23.73	7.37	7.98	5.20	3.43	2.97	0.88	1.92	0.30	1.35	0.13
30							12.36	26.97	7.89	9.06	5.58	3.89	3.18	1.00	2.06	0.35	1.44	0.15
35							14.42	35.88	9.21	12.06	6.51	5.18	3.72	1.33	2.40	0.46	1.68	0.19
40							16.48	45.95	10.52	15.44	7.44	6.63	4.25	1.70	2.75	0.59	1.93	0.25
45							18.54	57.15	11.84	19.20	8.37	8.25	4.78	2.12	3.00	0.73	2.17	0.31
50									13.16	23.34	9.30	10.03	5.31	2.57	3.44	0.89	2.41	0.38
55									14.47	27.85	10.23	11.97	5.84	3.07	3.78	1.06	2.65	0.45
60									15.79	32.71	11.16	14.06	6.37	3.60	4.12	1.25	2.89	0.53
65									17.10	37.94	12.09	16.31	6.91	4.18	4.47	1.45	3.13	0.61
70									18.42	43.52	13.02	18.70	7.44	4.80	4.81	1.66	3.37	0.70
75									19.74	49.45	13.95	21.25	7.97	5.45	5.16	1.89	3.62	0.80
80											14.88	23.95	8.50	6.14	5.50	2.13	3.86	0.90
85											15.81	26.80	9.03	6.87	5.84	2.38	4.10	1.01
90											16.74	29.79	9.56	7.64	6.19	2.65	4.34	1.12
95											17.67	32.93	10.09	8.44	6.53	2.93	4.58	1.24
100											18.60	36.21	10.63	9.28	6.88	3.22	4.82	1.36
110													11.69	11.08	7.56	3.84	5.31	1.62
120													12.75	13.01	8.25	4.52	5.79	1.91
130													13.82	15.09	8.94	5.24	6.27	2.21
140													14.88	17.31	9.63	6.01	6.75	2.54
150													15.94	19.67	10.32	6.83	7.24	2.88
160													17.01	22.17	11.00	7.69	7.72	3.25
170													18.07	24.81	11.69	8.61	8.20	3.64
180													19.13	27.58	12.38	9.57	8.69	4.04
190															13.07	10.58	9.17	4.47
200															13.76	11.63	9.65	4.91
225															15.48	14.47	10.86	6.11
250															17.20	17.58	12.07	7.43
275															18.92	20.98	13.27	8.86
300																	14.48	10.41
325																	15.69	12.07
350																	16.89	13.85
375																	18.10	15.73
400																	19.31	17.73
425																		
450																		
475																		
500																		
550																		
600																		

Note: Shaded areas of the chart indicate velocities over 7 feet per second (FPS). Use with caution.

CHARTS

Polyethylene (PE) SDR-Pressure Rated Tube

SIZES: 1/2" – 6" **FLOW:** 1 – 600 GPM **PSI LOSS:** Per 100' of tube (PSI/100 FT) **C = 140** (2306, 3206, 3306) SDR 7, 9, 11.5, 15

SIZE	1/2"		3/4"		1"		1 1/4"		1 1/2"		2"		2 1/2"		3"		4"		6"	
ID	0.622		0.824		1.049		1.380		1.610		2.067		2.469		3.068		4.026		6.065	
FLOW G. P. M.	Velocity FPS	psi Loss	Velocity FPS	psi Loss	Velocity FPS	psi Loss	Velocity FPS	psi Loss	Velocity FPS	psi Loss	Velocity FPS	psi Loss	Velocity FPS	psi Loss	Velocity FPS	psi Loss	Velocity FPS	psi Loss	Velocity FPS	psi Loss
1	1.05	0.49	0.60	0.12	0.37	0.04	0.21	0.01	0.15	0.00	0.09	0.00								
2	2.10	1.76	1.20	0.45	0.74	0.14	0.42	0.04	0.31	0.02	0.19	0.01								
3	3.16	3.73	1.80	0.95	1.11	0.29	0.64	0.08	0.47	0.04	0.28	0.01	0.20	0.00						
4	4.21	6.35	2.40	1.62	1.48	0.50	0.85	0.13	0.62	0.06	0.38	0.02	0.26	0.01						
5	5.27	9.60	3.00	2.44	1.85	0.76	1.07	0.20	0.78	0.09	0.47	0.03	0.33	0.01	0.21	0.00				
6	6.32	13.46	3.60	3.43	2.22	1.06	1.28	0.28	0.94	0.13	0.57	0.04	0.40	0.02	0.26	0.01				
7	7.38	17.91	4.20	4.56	2.59	1.41	1.49	0.37	1.10	0.18	0.66	0.05	0.46	0.02	0.30	0.01				
8	8.43	22.93	4.80	5.84	2.96	1.80	1.71	0.474	1.25	0.22	0.76	0.07	0.53	0.03	0.34	0.03				
9	9.49	28.52	5.40	7.26	3.33	2.24	1.92	0.59	1.41	0.28	0.85	0.08	0.60	0.03	0.39	0.01				
10	10.54	34.67	6.00	8.82	3.70	2.73	2.14	0.72	1.57	0.34	0.95	0.10	0.66	0.04	0.43	0.01				
11	11.60	41.36	6.00	10.53	4.07	3.25	2.35	0.86	1.73	0.40	1.05	0.12	0.73	0.05	0.47	0.02	0.27	0.00		
12	12.65	48.60	7.21	12.37	4.44	3.82	2.57	1.01	1.88	0.48	1.14	0.14	0.80	0.06	0.52	0.02	0.30	0.01		
14	14.76	64.65	8.41	16.46	5.19	5.08	2.99	1.34	2.20	0.63	1.33	0.19	0.93	0.08	0.60	0.03	0.35	0.01		
16	16.87	82.79	9.61	21.07	5.93	6.51	3.42	1.71	2.51	0.81	1.52	0.24	1.07	0.10	0.69	0.04	0.40	0.01		
18	18.89	102.97	10.81	26.21	6.67	8.10	3.85	2.13	2.83	1.01	1.71	0.30	1.20	0.13	0.78	0.04	0.45	0.01		
20			12.01	31.86	7.41	9.84	4.28	2.59	3.14	1.22	1.90	0.36	1.33	0.15	0.86	0.05	0.50	0.01		
22			13.21	38.01	8.15	11.74	4.71	3.09	3.46	1.46	2.10	0.43	1.47	0.18	0.95	0.06	0.55	0.02		
24			14.42	44.65	8.89	13.79	5.14	3.63	3.77	1.72	2.29	0.51	1.60	0.21	1.04	0.07	0.60	0.02		
26			15.62	41.79	9.64	16.00	5.57	4.21	4.09	1.99	2.48	0.59	1.74	0.25	1.12	0.09	0.65	0.02		
28			16.82	59.41	10.38	18.35	5.99	4.83	4.40	2.28	2.67	0.68	1.87	0.29	1.21	0.10	0.70	0.03		
30			18.02	67.50	11.12	20.85	6.42	5.49	4.72	2.59	2.86	0.77	2.00	0.32	1.30	0.11	0.75	0.03	0.33	0.00
35					12.97	27.74	7.49	7.31	5.50	3.45	3.34	1.02	2.34	0.43	1.51	0.15	0.88	0.04	0.38	0.01
40					14.83	35.53	8.56	9.36	6.29	4.42	3.81	1.31	2.67	0.55	1.73	0.19	1.00	0.05	0.44	0.01
45					16.68	44.19	9.64	11.64	7.08	5.50	4.29	1.63	3.01	0.69	1.95	0.24	1.13	0.06	0.49	0.01
50					18.53	53.71	10.71	14.14	7.87	6.68	4.77	1.98	3.34	0.83	2.16	0.29	1.25	0.08	0.55	0.01
55							11.78	16.87	8.65	7.97	5.25	2.36	3.68	1.00	2.38	0.35	1.38	0.09	0.61	0.01
60							12.85	19.82	9.44	9.36	5.72	2.78	4.01	1.17	2.60	0.41	1.51	0.11	0.66	0.01
65							13.92	22.99	10.23	10.86	6.20	3.22	4.35	1.36	2.81	0.47	1.63	0.13	0.72	0.02
70							14.99	26.37	11.01	12.46	6.68	3.69	4.68	1.56	3.03	0.54	1.76	0.14	0.77	0.02
75							16.06	29.97	11.80	14.16	7.16	4.20	5.01	1.77	3.25	0.61	1.88	0.16	0.83	0.02
80							17.13	33.77	12.59	15.95	7.63	4.73	5.35	1.99	3.46	0.69	2.01	0.18	0.88	0.03
85							18.21	37.79	13.37	17.85	8.11	5.29	5.68	2.23	3.68	0.77	2.13	0.21	0.94	0.03
90							19.28	42.01	14.16	19.84	8.59	5.88	6.02	2.48	3.90	0.86	2.26	0.23	0.99	0.03
95									14.95	21.93	9.07	6.50	6.35	2.74	4.11	0.95	2.39	0.25	1.05	0.03
100									15.74	24.12	9.54	7.15	6.69	3.01	4.33	1.05	2.51	0.28	1.10	0.04
110									17.31	28.77	10.50	8.53	7.36	3.59	4.76	1.25	2.76	0.33	1.22	0.05
120									18.88	33.80	11.45	10.02	8.03	4.22	5.20	1.47	3.02	0.39	1.33	0.05
130											12.41	11.62	8.70	4.90	5.63	1.70	3.27	0.45	1.44	0.06
140											13.36	13.33	9.37	5.62	6.06	1.95	3.52	0.52	1.55	0.07
150											14.32	15.15	10.03	6.38	6.50	2.22	3.77	0.59	1.66	0.08
160											15.27	17.08	10.70	7.19	6.93	2.50	4.02	0.67	1.77	0.09
170											16.23	19.11	11.37	8.05	7.36	2.80	4.27	0.75	1.88	0.10
180											17.18	21.24	12.04	8.95	7.08	3.11	4.53	0.83	1.99	0.11
190											18.14	23.48	12.71	9.89	8.23	3.44	4.78	0.92	2.10	0.12
200											19.09	25.81	13.38	10.87	8.66	3.78	5.03	1.01	2.21	0.14
225													15.05	13.52	9.75	4.70	5.66	1.25	2.49	0.17
250													16.73	16.44	10.83	5.71	6.29	1.52	2.77	0.21
275													18.40	19.61	11.92	6.82	6.92	1.82	3.05	0.25
300															13.00	8.01	7.55	2.13	3.32	0.29
325															14.08	9.29	8.18	2.48	3.60	0.34
350															15.17	10.65	8.81	2.84	3.88	0.39
375															16.25	12.10	9.43	3.23	4.15	0.44
400															17.33	13.64	10.06	3.64	4.43	0.50
425															18.42	15.26	10.69	4.07	4.71	0.55
450															19.50	16.97	11.32	4.52	4.99	0.62
475																	11.95	5.00	5.26	0.68
500																	12.58	5.50	5.54	0.75
550																	13.84	6.56	6.10	0.89
600																	15.10	7.70	6.65	1.05

Note: Shaded areas of the chart indicate velocities over 5 feet per second (FPS). Use with caution.

CHARTS

Schedule 40 Standard Steel Pipe

SIZES: 1/2" – 6" **FLOW:** 1 – 600 GPM **PSI LOSS:** Per 100' of pipe (PSI/100 FT) **C = 100 15**

SIZE	1/2"		3/4"		1"		1 1/4"		1 1/2"		2"		2 1/2"		3"		4"		6"	
OD	0.840		1.050		1.315		1.660		1.900		2.375		2.875		3.500		4.500		6.625	
ID	0.622		0.824		1.049		1.380		1.610		2.067		2.469		3.068		4.026		6.065	
WALL THK.	0.109		0.113		0.133		0.140		0.145		0.154		0.203		0.216		0.237		0.280	
FLOW G. P. M.	Velocity FPS	psi Loss	Velocity FPS	psi Loss	Velocity FPS	psi Loss	Velocity FPS	psi Loss	Velocity FPS	psi Loss	Velocity FPS	psi Loss	Velocity FPS	psi Loss	Velocity FPS	psi Loss	Velocity FPS	psi Loss	Velocity FPS	psi Loss
1	1.05	0.91	0.60	0.23	0.37	0.07	0.21	0.02	0.15	0.01	0.09	0.00								
2	2.10	3.28	1.20	0.84	0.74	0.26	0.42	0.07	0.31	0.03	0.19	0.01	0.13	0.00						
3	3.16	6.95	1.80	1.77	1.11	0.55	0.64	0.14	0.47	0.07	0.28	0.02	0.20	0.01	0.13	0.00				
4	4.21	11.85	2.40	3.02	1.48	0.93	0.85	0.25	0.62	0.12	0.38	0.03	0.26	0.01	0.17	0.01				
5	5.27	17.91	3.00	4.56	1.85	1.41	1.07	0.37	0.78	0.18	0.47	0.05	0.33	0.02	0.21	0.01				
6	6.32	25.10	3.60	6.39	2.22	1.97	1.28	0.52	0.94	0.25	0.57	0.07	0.40	0.03	0.26	0.01				
7	7.38	33.40	4.20	8.50	2.59	2.63	1.49	0.69	1.10	0.33	0.66	0.10	0.46	0.04	0.30	0.01				
8	8.43	42.77	4.80	10.89	2.96	3.36	1.71	0.89	1.25	0.42	0.76	0.12	0.53	0.05	0.34	0.02	0.20	0.00		
9	9.49	53.19	5.40	13.54	3.33	4.18	1.92	1.10	1.41	0.52	0.85	0.15	0.60	0.06	0.39	0.02	0.22	0.01		
10	10.54	64.65	6.00	16.46	3.70	5.08	2.14	1.34	1.57	0.63	0.95	0.19	0.66	0.08	0.43	0.03	0.25	0.01		
11	11.60	77.13	6.60	19.63	4.07	6.07	2.35	1.60	1.73	0.75	1.05	0.22	0.73	0.09	0.47	0.03	0.27	0.01		
12	12.65	90.62	7.21	23.07	4.44	7.13	2.57	1.88	1.88	0.89	1.14	0.26	0.80	0.11	0.52	0.04	0.30	0.01		
14	14.76	20.56	8.41	30.69	5.19	9.48	2.99	2.50	2.20	1.18	1.33	0.35	0.93	0.15	0.60	0.05	0.35	0.01		
16	16.87	54.39	9.61	39.30	5.93	12.14	3.42	3.20	2.51	1.51	1.52	0.45	1.07	0.19	0.69	0.07	0.40	0.02		
18	18.89	92.02	10.81	48.88	6.67	15.10	3.85	3.98	2.83	1.88	1.71	0.56	1.20	0.23	0.78	0.08	0.45	0.02		
20			12.01	59.41	7.41	18.35	4.28	4.83	3.14	2.28	1.90	0.68	1.33	0.29	0.86	0.10	0.50	0.03		
22			13.21	70.88	8.15	21.90	4.71	5.77	3.46	2.72	2.10	0.81	1.47	0.34	0.95	0.12	0.55	0.03	0.24	0.00
24			14.42	83.27	8.89	25.72	5.14	6.77	3.77	3.20	2.29	0.95	1.60	0.40	1.04	0.14	0.60	0.04	0.26	0.01
26			15.62	96.57	9.64	29.83	5.57	7.86	4.09	3.71	2.48	1.10	1.74	0.46	1.12	0.16	0.65	0.04	0.28	0.01
28			16.82	110.8	10.38	34.22	5.99	9.01	4.40	4.26	2.67	1.26	1.87	0.53	1.21	0.18	0.70	0.05	0.31	0.01
30			18.02	125.9	11.12	38.89	6.42	10.24	4.72	4.84	2.86	1.43	2.00	0.60	1.30	0.21	0.75	0.06	0.33	0.01
35					12.97	51.74	7.49	13.62	5.50	6.44	3.34	1.91	2.34	0.80	1.51	0.28	0.88	0.07	0.38	0.01
40					14.83	66.25	8.56	17.45	6.29	8.24	3.81	2.44	2.67	1.03	1.73	0.36	1.00	0.10	0.44	0.01
45					16.68	82.40	9.64	21.70	7.08	10.25	4.29	3.04	3.01	1.28	1.95	0.44	1.13	0.12	0.49	0.02
50					18.53	100.2	10.71	26.37	7.87	12.46	4.77	3.69	3.34	1.56	2.16	0.54	1.25	0.14	0.55	0.02
55							11.78	31.47	8.65	14.86	5.25	4.41	3.68	1.86	2.38	0.65	1.38	0.17	0.61	0.02
60							12.85	36.97	9.44	17.46	5.72	5.18	4.01	2.18	2.60	0.76	1.51	0.20	0.66	0.03
65							13.92	42.88	10.23	20.25	6.20	6.00	4.35	2.53	2.81	0.88	1.63	0.23	0.72	0.03
70							14.99	49.18	11.01	23.23	6.68	6.89	4.68	2.90	3.03	1.01	1.76	0.27	0.77	0.04
75							16.06	55.89	11.80	26.40	7.16	7.83	5.01	3.30	3.25	1.15	1.88	0.31	0.83	0.04
80							17.13	62.98	12.59	29.75	7.63	8.82	5.35	3.72	3.46	1.29	2.01	0.34	0.88	0.05
85							18.21	70.47	13.37	33.29	8.11	9.87	5.68	4.16	3.68	1.44	2.13	0.39	0.94	0.05
90							19.28	78.33	14.16	37.00	8.59	10.97	6.02	4.62	3.90	1.61	2.26	0.43	0.99	0.06
95									14.95	40.90	9.07	12.13	6.35	5.11	4.11	1.78	2.39	0.47	1.05	0.06
100									15.74	44.97	9.54	13.33	6.69	5.62	4.33	1.95	2.51	0.52	1.10	0.07
110									17.31	53.66	10.50	15.91	7.36	6.7	4.76	2.33	2.76	0.62	1.22	0.08
120									18.88	63.04	11.45	18.69	8.03	7.87	5.20	2.74	3.02	0.73	1.33	0.10
130											12.41	21.68	8.70	9.13	5.63	3.17	3.27	0.85	1.44	0.12
140											13.36	24.87	9.37	10.47	6.06	3.64	3.52	0.97	1.55	0.13
150											14.32	28.26	10.03	11.90	6.50	4.14	3.77	1.10	1.66	0.15
160											15.27	31.84	10.70	13.41	6.93	4.66	4.02	1.24	1.77	0.17
170											16.23	35.63	11.37	15.01	7.36	5.22	4.27	1.39	1.88	0.19
180											17.18	39.61	12.04	16.68	7.80	5.80	4.53	1.55	1.99	0.21
190											18.14	43.78	12.71	18.44	8.23	6.41	4.78	1.71	2.10	0.23
200											19.09	48.14	13.38	20.28	8.66	7.05	5.03	1.88	2.21	0.26
225													15.08	25.22	9.75	8.76	5.66	2.34	2.49	0.32
250													16.73	30.65	10.83	10.65	6.29	2.84	2.77	0.39
275													18.40	36.57	11.92	12.71	6.92	3.39	3.05	0.46
300															13.00	14.93	7.55	3.98	3.32	0.54
325															14.08	17.32	8.18	4.62	3.60	0.63
350															15.17	19.87	8.81	5.30	3.88	0.72
375															16.25	22.57	9.43	6.02	4.15	0.82
400															17.33	25.44	10.06	6.78	4.43	0.92
425															18.42	28.46	10.69	7.59	4.71	1.03
450															19.50	31.64	11.32	8.43	4.99	1.15
475																	11.95	9.32	5.26	1.27
500																	12.58	10.25	5.54	1.40
550																	13.84	12.23	6.10	1.67
600																	15.10	14.37	6.65	1.96

Note: Shaded areas of the chart indicate velocities over 7 feet per second (FPS). Use with caution.



K
RAIN®

DESIGN RESOURCES FOR IRRIGATION PROFESSIONALS

The K-Rain® website, www.krain.com is a resource for product manuals, videos, FAQs and other valuable information. But it also is an online tool for design and installation of our products. Whether you are a landscape architect, irrigation designer or other irrigation professional, K-Rain® has developed libraries to help you quickly find the information you need. Visit the site for CAD detail drawing and irrigation designs for sports fields and more.

CAD DETAIL DRAWINGS

www.krain.com/cad-detail-drawings

Lay out your irrigation design effectively and efficiently. We offer 2 file formats for each part number for your convenience. PDF and CAD, or computer-aided design (CAD) for:

- Irrigation Controllers & Rain Sensor
- Rotors
- Pro-S™ Sprays
- Pro-S™ Sprays with Rotary Nozzles
- Valves

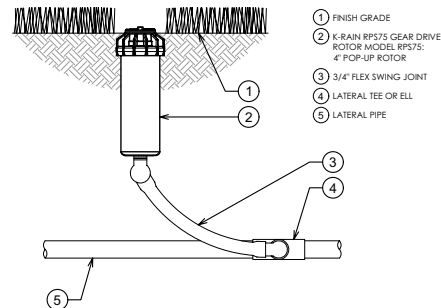

00 K-RAIN RPS75 ROTOR WITH 4\"/>

IRRIGATION DESIGNS FOR SPORTS FIELDS

www.krain.com/sports-field-design

Our Sports Field Irrigation Designs contain Irrigation Design Criteria for water source and head layouts. There you will find pressure and flow water requirements along with general head spacing by field type. A graphic scale is provided on each field type.

- Baseball
 - ▶ Baseball Field-5 Row
- Football
 - ▶ Football Field-4 Row
 - ▶ Football Field-5 Row
- Little League Field
 - ▶ Little League Field-3 Row
- Soccer
 - ▶ Soccer Field-5 Row
 - ▶ Soccer Field-6 Row (ProSport)
 - ▶ Soccer Field-6 Row (RPS75i)
- Tennis
 - ▶ Double Tennis Court-3 Row

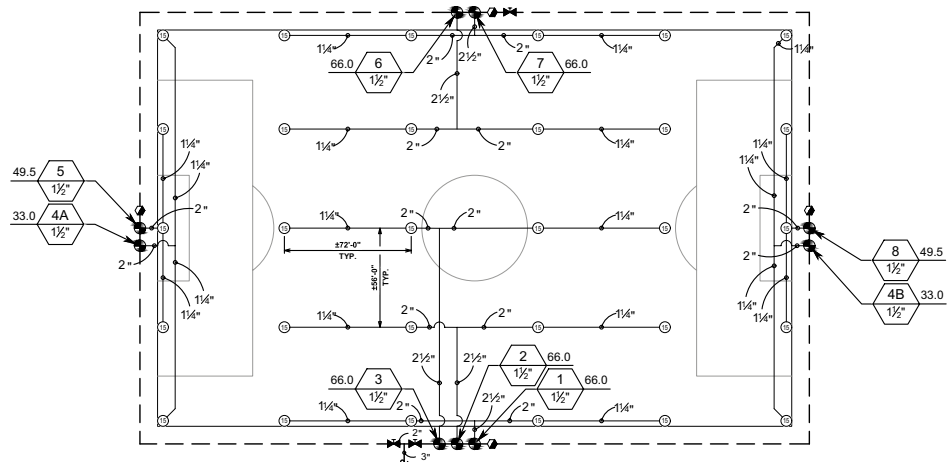

WARRANTY

Limited Product Warranty

All K-Rain® gear drive rotors, sprays and valves carry a five year “**Limited Warranty**” from the date of purchase. All electronic K-Rain® products carry a two year “**Limited Warranty**” from the date of purchase unless otherwise stated. During this period K-Rain® will repair or replace (at the option of K-Rain®) the product or any part if the product is found to be defective as to workmanship or material.

This warranty does not extend to damage to a K-Rain® product resulting from misuse, neglect or abuse, normal wear and tear, or accident, to exterior appearance or color or due to improper installation. Various products may carry a longer warranty time period; check individual product specification sheets for warranty period.

This warranty extends only to an original user of a K-Rain® product.

IN NO EVENT SHALL K-RAIN® BE LIABLE FOR INCIDENTAL OR CONSEQUENTIAL DAMAGES. ALL IMPLIED WARRANTIES ARE LIMITED IN DURATION TO TWO YEARS FOLLOWING DATE OF PURCHASE UNLESS INDICATED OTHERWISE.

Some U.S. states do not permit the exclusion or limitation of incidental or consequential damages or of implied warranties. Therefore, the above exclusions or limitations may not apply to you. If a defect arises in a K-Rain® product within the warranty period, you should promptly contact your K-Rain® installer, distributor or K-RAIN® MANUFACTURING CORPORATION.

This warranty gives you specific legal rights, and you may also have other rights which vary from state to state. If you have any questions concerning the warranty or its application, please contact K-Rain®:

K-Rain® Manufacturing Corp.
1640 Australian Avenue
Riviera Beach, FL 33404 USA
561.844.1002
FAX: 561.842.9493
1.800.735.7246 | www.krain.com



K-Rain® Manufacturing Corp.
1640 Australian Avenue
Riviera Beach, FL 33404 USA
561.844.1002
FAX: 561.842.9493
1.800.735.7246 | www.krain.com

© K-Rain Manufacturing Corporation
AN ISO 9001 CERTIFIED COMPANY

Follow us on
social media:

