

60500B SERIES

DRAW-OFF, GRAVITY TYPE

APPLICATION

For use in service stations, parking garages, car and truck washes and industrial plants where discharged water contains oil, sediment and other volatile liquids. Separator collects oil and conveniently permits the collected oil to be drained to a storage tank by means of an adjustable gravity draw-off connection. Sediment and debris are collected in a sediment bucket that can be periodically removed.

SPECIFICATION

JOSAM 60500B Series fabricated steel Oil Separator, epoxy coated inside and outside, threaded connections, internal trap, sediment bucket, two vent connections on each side, gasketed non-skid cover and flow control fitting.

Available Options

- ▼ -EXT Extension, 6" Standard (Specify Extension Height)
- 60 Anchor Flange
- 61 Flange and Clamp Device
- HD Heavy-Duty Cover

• 3" sizes normally furnished with 4" x 3" reducing bushings.

TYPE NO.	FLOW RATE GPM	PIPE SIZE	ROUGH-IN CENTERS		LGTH. E	WIDTH F	HGT. G	VENT & DRAW OFF ROUGH-IN			LBS.
			C	D				M	R	S	
60503B	10	2	10-1/2	4-1/8	15-7/16	12-3/8	14-5/8	6-5/8	2-7/8	8-1/2	55
60504B	15	2	12-3/4	3-3/8	18-3/16	14-1/2	16-1/8	8	2-5/8	10-3/4	72
60505B	20	3•	14-5/8	4-3/8	19-15/16	16-3/8	19	8-7/8	2-3/4	12	85
60506B	25	3•	16	4	21-11/16	17-1/2	20	9-3/4	2-3/4	13-1/2	105
60507B	35	3•	16-3/4	4-7/8	25-5/16	19-1/4	21-5/8	11-9/16	2-3/4	14-1/4	130
60508B	50	3•	18-1/2	6-1/4	28-11/16	21-1/2	24-3/4	13-1/4	3	16	155

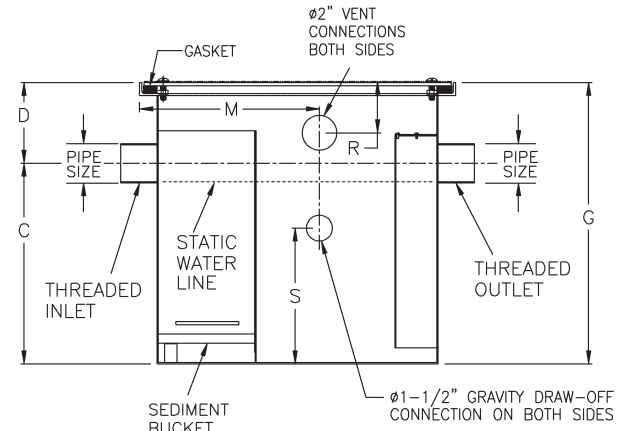
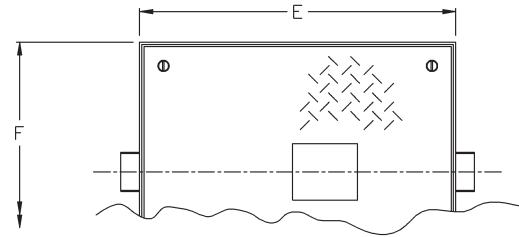

INTERCEPTORS

60500B-EXT SERIES

with Extension

APPLICATION

For use in service stations, parking garages, car and truck washes and industrial plants where discharged water contains oil, sediment and other volatile liquids. Separator collects oil and conveniently permits the collected oil to be drained to a storage tank by means of an adjustable gravity draw-off connection. Sediment and debris are collected in a sediment bucket that can be periodically removed. An extended top with fixed extension is supplied for installations requiring additional roughing depth from center of inlet and outlet to finished floor height.

SPECIFICATION

JOSAM 60500B-EXT Series fabricated steel Oil Separator, epoxy coated inside and outside, threaded connections, deep roughing, integral extension, internal trap, sediment bucket, two vent connections on each side, gasketed non-skid cover and flow control fitting.

• 3" sizes normally furnished with 4" x 3" reducing bushings.

TYPE NO.	FLOW RATE GPM	PIPE SIZE	ROUGH-IN CENTERS		LGTH. E	WIDTH F	HGT. G♦	VENT & DRAW OFF ROUGH-IN			LBS.
			C	D♦				M	R	S	
60503B-EXT	10	2	10-1/2	10-1/8	15-7/16	12-3/8	20-5/8	6-5/8	2-7/8	8-1/2	55
60504B-EXT	15	2	12-3/4	9-3/8	18-3/16	14-1/2	22-1/8	8	2-5/8	10-3/4	72
60505B-EXT	20	3•	14-5/8	10-3/8	19-15/16	16-3/8	25	8-7/8	2-3/4	12	85
60506B-EXT	25	3•	16	10	21-11/16	17-1/2	26	9-3/4	2-3/4	13-1/2	105
60507B-EXT	35	3•	16-3/4	10-7/8	25-5/16	19-1/4	27-5/8	11-9/16	2-3/4	14-1/4	130
60508B-EXT	50	3•	18-1/2	12-1/4	28-11/16	21-1/2	30-3/4	13-1/4	3	16	155

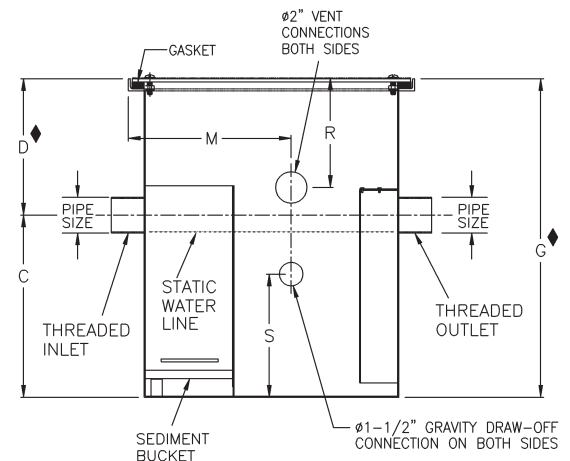
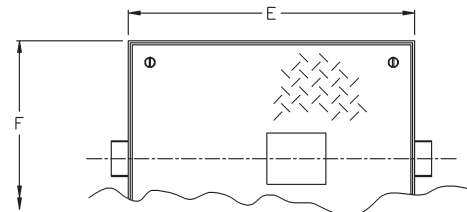

♦ DIMENSIONS BASED ON STD. 6" EXTENSION.