

SPECIFICATION:

JOSAM SERIES "A" ADJUSTABLE SATIN FINISH NIKALOY ROUND "SUPER - FLO" STRAINER THREADED WITH JOSAM ADJUSTABLE STRAINER THREAD.

**FLOOR DRAIN
ADJUSTABLE STRAINER**

SERIES

A

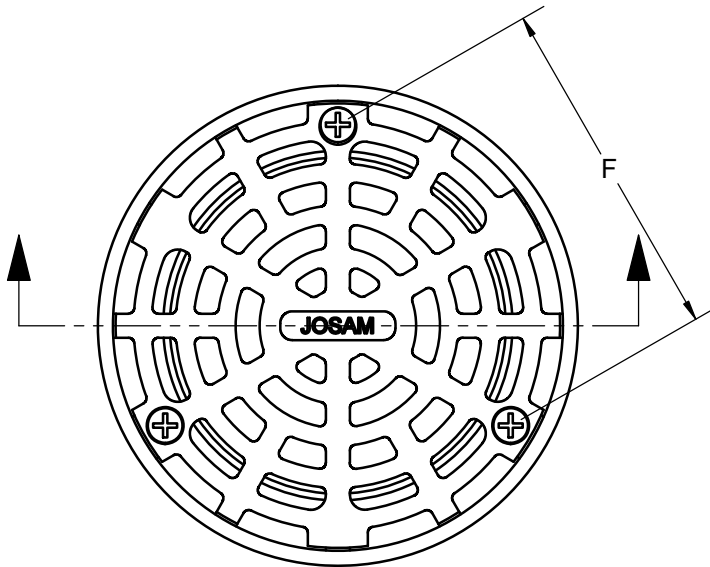

5A-6A-7A-8A
SLOT WIDTH : 1/4"
MEETS ADA AND HEEL-PROOF REQS.

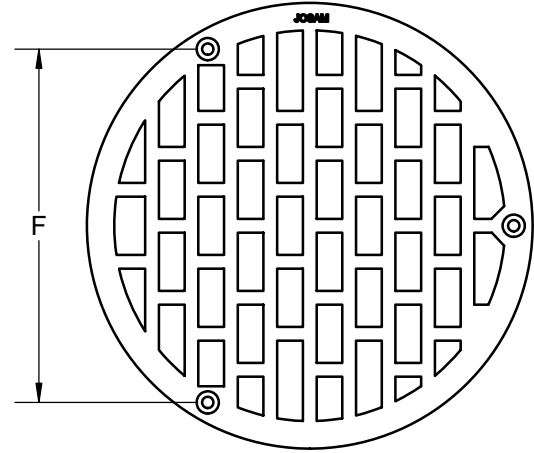

9A-10A
SLOT WIDTH : 1/2"
MEETS ADA REQS.

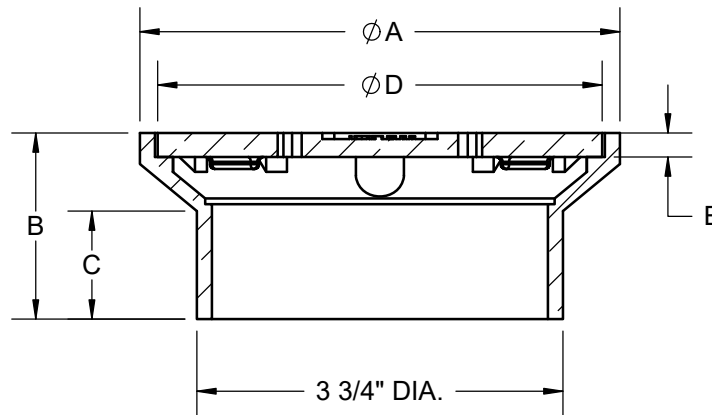

	TYPE NO.	A	B	C	D	E	F	FREE AREA	LBS.
	5A	5	1-15/16	1-1/8	4-5/8	1/4	3-5/8	7.8	2
	6A	6	2-1/4	15/16	5-1/4	1/4	4-11/64	11.0	3
	7A	7	2-11/16	1-1/2	6-7/16	7/32	5-1/32	13.2	4
	8A	8	2-1/2	7/8	7-1/8	7/32	5-3/4	16.2	5
	9A*	9	2-1/4	1	8-1/8	7/32	6-7/16	21.1	7
	10A*	10	2-1/4	1-1/8	9-5/32	9/32	7-27/64	28.0	9

* Not SUPER-FLO Design

-HD	HEAVY DUTY LOAD RATING (5A & 6A ONLY)	-DBC	DEBRIS COVER (5A, 6A, 8A)
-3	BUFF POLISH NIKALOY	-4	BUFF POLISH BRASS
-SS	STAINLESS STEEL (5A, 6A, 7A, 8A)	-CP	CHROME PLATED STRAINER (5A & 6A)
-2	BRONZE ADJUSTABLE STRAINER	-J	BACKWATER VALVE
-80	PERFORATED STAINLESS STEEL BASKET	-VP	SECURED GRATE, VANDAL-PROOF SCREWS

DATE OF LAST CHANGE: 05/08/17

DIMENSIONS ARE SUBJECT TO MANUFACTURERS TOLERANCES AND CHANGE WITHOUT NOTICE. WE CAN ASSUME NO RESPONSIBILITY FOR USE OF SUPERSEDED OR VOID DATA.

JOSAM COMPANY
MICHIGAN CITY, INDIANA

NOTES