

STUDOR.

IPS CORPORATION

InVENTive TECHNOLOGY®

P.A.P.A.™
Positive Air Pressure Attenuator
PAT. PENDING.

MADE IN THE USA
PATENT PENDING
STUDOR.
IPS CORPORATION
TEC-VENT™

10th EDITION

ENGINEERED PRODUCTS MANUAL

STUDOR ENGINEERED PRODUCTS TECHNICAL MANUAL

Studor Overview	2
Products	
Redi-Vent	3
Mini-Vent	4
Maxi-Vent & Maxi-Cap.....	5
Maxi-Filtra	6
Tec-Vent	7
Chem-Vent	8
Air Admittance Valve Tee & Trap-Vent	9
P.A.P.A.	10
Recess Boxes - In Wall (Non-Fire Rated) (Fire Rated)	11
Outdoor Air Admittance Valve Installation	12
Introduction To:	
Air Admittance Valves	13
Design Criteria	
Air Admittance Installation Criteria	16
Air Admittance Installation Design Criteria	17
Air Admittance Valve Installation.....	24
Studor Drawings	
Island Sinks / Washing Machines / Lavatory Sinks / Kitchen Sinks.....	26
Grease Trap / Sewer Ejector	30
Standards and Listings	
Air Admittance Valves	31
Codes	
IPC, IRC, UPC, NSPC, National Plumbing Code of Canada	32
Introduction To:	
P.A.P.A. (Positive Air Pressure Attenuator)	33
Design Installation / Criteria	
P.A.P.A. (Positive Air Pressure Attenuator) Installation	35
P.A.P.A. Design Criteria “Studor Single Pipe System (SSP)”	37
Studor Riser Diagrams	
“Studor Single Pipe System (SSPS)”	42
Standards and Listings	
P.A.P.A. (Positive Air Pressure Attenuator)	45
Research	
John Swaffield and Dr. Michael Gormley	46
Material Properties	
Maxi-Vent, Mini-Vent, Redi-Vent	50
Tec-Vent	51
Chem-Vent	52
P.A.P.A.	53
Product Specifications	
(CSI-3)	54
Product References / Technical Assistance	62
Studor Advantage / Problem Solving	63
Warranty	64

This Manual was Crafted for the 21st Century Design Professional

STUDOR OVERVIEW

Air Admittance Valves (AAVs) are devices that were created to solve problems with the open pipe venting systems and can serve as a vent for Drainage Waste and Vent (DWV) systems in lieu of open pipe vents. The STUDOR brand AAVs were invented by Sture Ericson and installed in Europe starting in the early 1970s; Ericson brought them into the USA in 1986. Since their introduction, millions of valves have been installed worldwide, and they are operating successfully.

STUDOR is the world recognized leader in innovative drain waste and vent products and designs. Greater efficiency and significant savings make STUDOR products the #1 choice worldwide.

STUDOR worked with the American Society of Sanitary Engineering (ASSE) to create the nationally recognized consensus standards for these valves. In 1990, ASSE published the first performance standard for AAVs (ASSE 1051) for single fixture and branch devices which were followed by ASSE 1050 for stack-type devices in 1991. The standards were revised in 2002 and are ANSI accredited. Today STUDOR works with the code officials on national, regional, state and local levels to educate, gain approval and promote the understanding of the benefits of AAVs.

In addition to the Air Admittance Valves, the P.A.P.A.[™] device was designed to eliminate or reduce the shock waves to a manageable level, which are formed in multi-story buildings. Together, the "Studor Single Pipe System (SSPS)" was created.

Studor worked with the American Society of Sanitary Engineering (ASSE) to create the first performance standard (ASSE 1030) for Positive Pressure Reduction Devices for Sanitary Drainage Systems.

Because of STUDOR's much greater experience and exposure to a variety of different applications worldwide, we have been able to identify unique conditions present in commercial and industrial applications not found in the residential realm and have designed products for the most demanding residential, commercial and industrial applications.



The Studor AAV was initially developed by Sture Ericson who applied for the patent on his first designed valve, the Bjare Valve, in July 1973. The valve was named after a specific region of Sweden where his factory was located.

The Bjare Valve

** The Studor AAVs are designed with vermin protective screens both inside and outside to protect the seal & seat from insects, debris, or foreign objects from entering the valve.



REDI-VENT®



- For Residential and Commercial use
- ANSI/ASSE 1051, 1050, NSF 14, Warnock Hersey, C-IAPMO, ICC-ES PMG-1025
- For venting single fixtures, kitchen sinks and bathroom groups including back-to-back applications up to 20 DFUs
- Compact size
- Exclusive vermin protection system
- Fits 1-1/2" or 2" pipe size
- Limited lifetime warranty
- Temperature Rating -40° F to +150° F (-40° C to +65.6° C)

DIMENSIONS

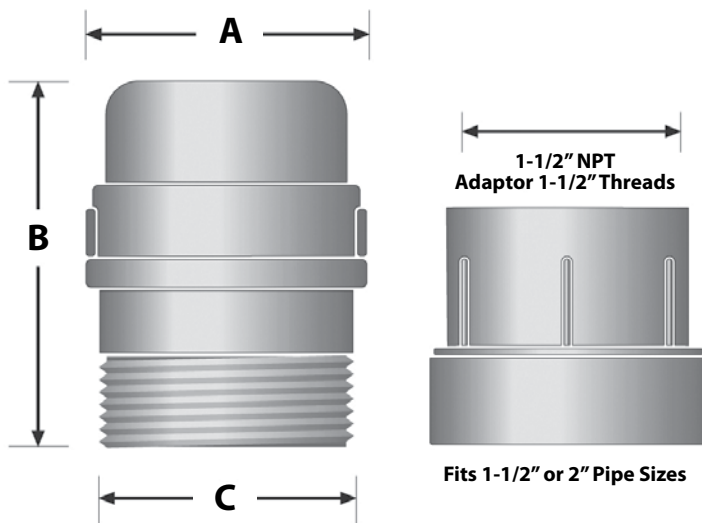

Nominal Pipe Size		
A	B	C
2"	2-5/8"	1-1/2" NPT

DFU

Horizontal Branch	Minimum Vent Pipe Size	Maximum DFUs on Branch
1-1/2"	1-1/4" - 1-1/2"	3
2"	1-1/4" - 2"	6
3"	1-1/2" - 3"	20
4"	2" - 4"	20

MINI-VENT®



- For Residential and Commercial use
- ANSI/ASSE 1051, 1050, NSF 14, Warnock Hersey, C-IAPMO, ICC-ES PMG-1025
- Can be used as an Individual, Branch, Circuit Vent or Stack Vent
- Will vent up to 160 DFUs
- Protective cover for outdoor use
- Exclusive vermin protection system
- Fits 1-1/2" or 2" pipe size
- Limited lifetime warranty
- Temperature Rating -40° F to +150° F (-40° C to +65.6° C)

DIMENSIONS

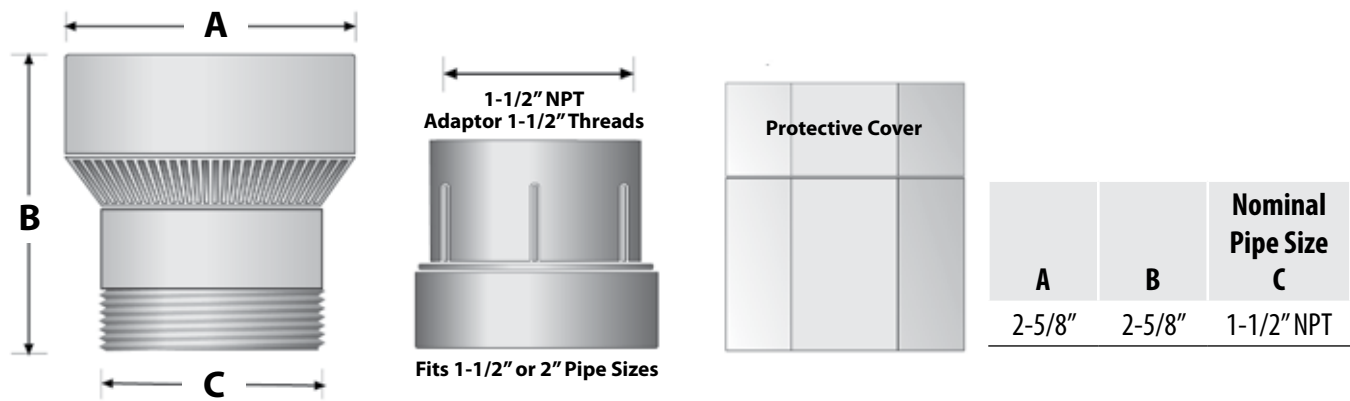

Studor recommends the use of the protective cover when installing the Mini-Vent® outdoors. The protective cover may also be used indoors for extra protection.

DFU

Horizontal Branch	Minimum Vent Pipe Size	Maximum DFUs on Branch
1-1/2"	1-1/4" - 1-1/2"	3
2"	1-1/4" - 2"	6
3"	1-1/2" - 3"	20
4"	2" - 4"	160

Stack Size	Maximum DFUs
1-1/2"	8
2"	24

MAXI-VENT®



- For Residential and Commercial use
- ANSI/ASSE 1051, 1050, NSF 14, Warnock Hersey, C-IAPMO, ICC-ES PMG-1025
- Can be used as an Individual, Branch, Circuit Vent or Stack Vent
- Will vent up to 500 DFUs
- Exclusive vermin protection system
- Fits 3" or 4" pipes - when connecting to 3" pipe - remove push-fit connector and couple with a no-hub type band
- Limited lifetime warranty
- Studor recommends the use of the Maxi-Cap when installing the Maxi-Vent® outdoors
- Temperature Rating -40° F to +150° F (-40° C to +65.6° C)

DIMENSIONS

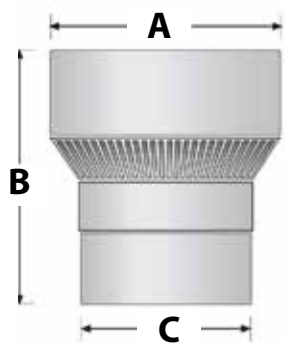

Protective Styrofoam Cover		4" Push-Fit Connector
A	B	Nominal Pipe Size C
4-7/8"	5-1/4"	3" Spigot

DFU

Horizontal Branch Size	Maximum DFUs	Stack Size	Maximum DFUs
3"	20	3"	72
4"	160	4"	500

MAXI-CAP

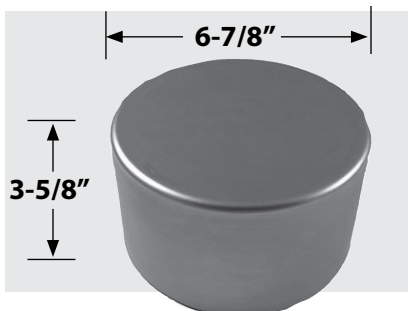

General Outside Use:

The Maxi-Cap can be installed on the Maxi-Vent® in outdoor installations to protect the Maxi-Vent® from damaging UV Rays and extreme temperatures.

Installation:

Fits over the styrofoam cover and the Maxi-Vent®

- Install styrofoam cap to valve
- Attach metal cap to styrofoam with double-sided adhesive
- Ensure that one open vent pipe is maintained
- If desired, paint cap prior to installation

MAXI-FILTRA®



- A two way vent which filters air in both directions
- For outdoor use only
- Replaceable carbon filter to eliminate bad odors and lasts up to 2 years
- Designed for installation on septic tanks and lift stations
- UV Rated
- Fits 3" of 4" pipes - when connecting to 3" pipe - remove push-fit connector and couple with a no-hub type band

Buildings connected to the main sewer can also benefit from the use of the Maxi-Filtra® but the Studor technical department must be contacted so that installation feasibility can be determined. The Maxi-Filtra®, as part of the complete STUDOR System®, eliminates sewer gases from entering buildings or polluting the surrounding areas. It can also be retro-fitted in existing plumbing system provided that all design and installation criteria are met.

DIMENSIONS

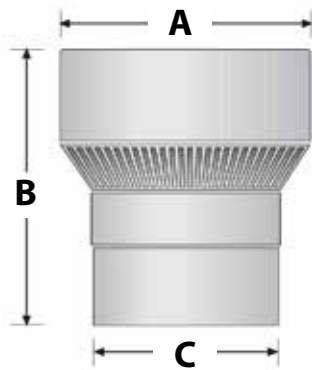

4" Push-Fit Connector



Nominal Pipe Size		
A	B	C
4-7/8"	5-1/4"	3" Spigot

OUTDOOR USE ONLY



Maxi-Filtra®



Adaptor



Replacement Cartridge

TEC-VENT®



- For Residential and Commercial use
- ANSI/ASSE 1051, 1050, NSF 14, Warnock Hersey, C-IAPMO, UL2043, ICC-ES PMG-1025
- Listed in accordance with UL2043 for installation in plenums when the system is designed by a design professional and approved by a local code official
- Manufactured from flame-retardant polycarbonate resin
- High tensile strength
- Will vent up to 160 DFUs
- UV Rated for outside installations
- Exclusive vermin protection system
- Fits 1-1/2" pipe size
- Limited lifetime warranty
- Temperature Rating -40° F to +150° F (-40° C to +65.6° C)

The Tec-Vent® features a material which is both flame-retardant (self-extinguishing) and possesses advanced flame properties. The Tec-Vent® is ideal for commercial projects such as schools, hospitals, hotels, airports and many other applications.

DIMENSIONS

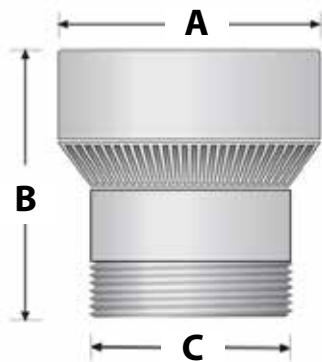

A	B	Nominal Pipe Size C
2-5/8"	2-5/8"	1-1/2" NPT

DFU

Horizontal Branch	Minimum Vent Pipe Size	Maximum DFUs on Branch
1-1/2"	1-1/4" - 1-1/2"	3
2"	1-1/4" - 2"	6
3"	1-1/2" - 3"	20
4"	2" - 4"	160

Stack Size	Maximum DFUs
1-1/2"	8
2"	24



- For Commercial use
- NSF 14, ASSE 1049 Performance Requirements for Individual and Branch Type Air Admittance Valves for Chemical Waste Systems
- Manufactured from flame-retardant polypropylene conforming to ASTM D-4101
- Will vent up to 6 DFUs
- Exclusive vermin protection system
- Limited lifetime warranty
- Temperature Rating -40° F to +212° F (-40° C to +100° C)

DIMENSIONS



Height A	Nominal Pipe Size
5-3/4"	1-1/2" DWV Pipe

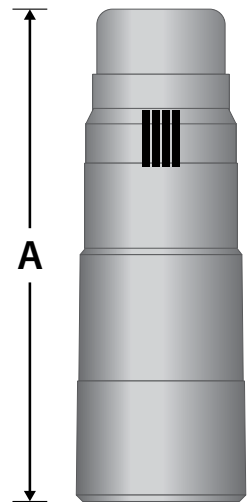

DFU

Horizontal Branch	Minimum Vent Pipe Size	Maximum DFUs on Branch
1-1/2"	1-1/4" - 1-1/2"	3
2"	1-1/4" - 2"	6

The extended spigot schedule 40 connection allows direct mount on any acid waste system (MJ or Fusion) as well as CPVC, glass or Duriron system with an adaptor

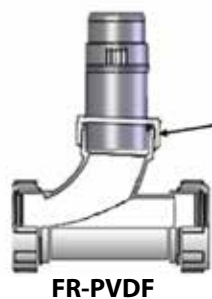

AAV Tee / TRAP-VENT®

AAV Tee (Redi-Vent with Tubular Adaptor)



- For Residential and Commercial use
- ANSI/ASSE 1051, 1050, NSF 14, Warnock Hersey, C-IAPMO, ICC-ES PMG-1025
- For venting single fixtures, kitchen sinks and bathroom groups including back-to-back applications up to 20 DFU
- Compact size
- Exclusive vermin protection system
- Limited lifetime warranty

DIMENSIONS

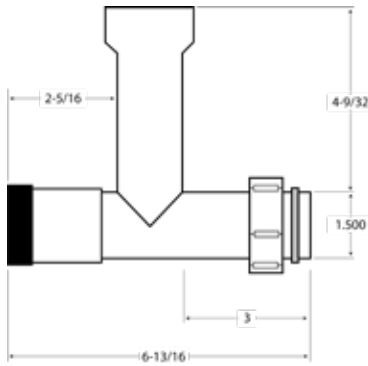

A	B	Nominal Pipe Size C
2"	2-5/8"	1-1/2" NPT

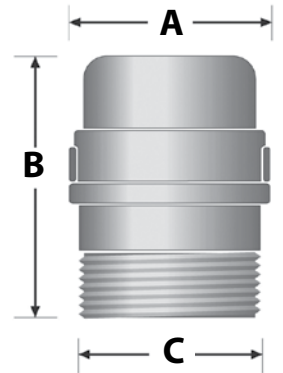

DFU

Horizontal Branch	Minimum Vent Pipe Size	Maximum DFUs on Branch
1-1/2"	1-1/4" - 1-1/2"	3
2"	1-1/4" - 2"	6
3"	1-1/2" - 3"	20
4"	2" - 4"	20

TRAP-VENT®

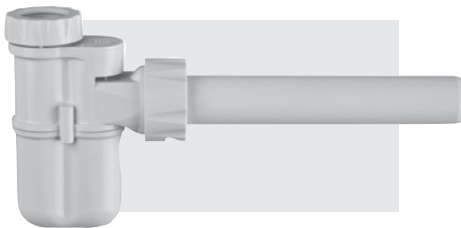

Code compliance will vary per State and Municipality - Please verify with your local code officials before installing

- Lavatory P-Trap with integral Air Admittance Valve
- For use on a lavatory, water cooler or sink that does not receive a discharge from any appliance
- ASSE 1051, NSF 14
- Up to 6 DFUs
- Limited lifetime warranty
- Trap-Vent® cannot be installed on kitchen sinks, laundry tub or a sink that receives a discharge from any kind of appliance
- Note: Listings subject to change

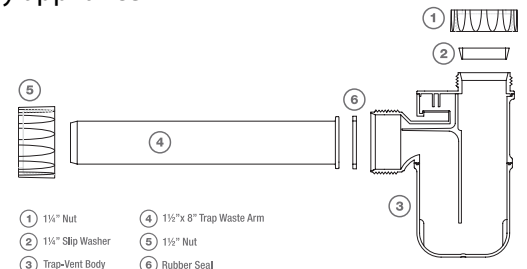

Note: Available with 1-1/4" or 1-1/2" trap waste arm

P.A.P.A.™ - Positive Air Pressure Attenuator



The P.A.P.A. device is the perfect complement to STUDOR Air Admittance Valves. Together they form an Engineered System known as “Studor Single Pipe System (SSPS)”, a total solution to building venting requirements. The Studor AAVs deal with negative pressure in the system while the P.A.P.A. effectively deals with the positive pressure transients. The combination of the two maintains the perfect system balance quickly and efficiently throughout the system preventing siphonage and blowing of traps.

- For Commercial use
- The P.A.P.A. can be used in conjunction with a conventional DWV system
- ASSE 1030 - Positive Pressure Reduction Devices for Sanitary Drainage Systems
- Temperature Rating -40° F to +150° F (-40° C to +65.6° C)

DIMENSIONS

		Nominal Pipe Size
A	B	C
7-7/8"	29-1/2"	3" Spigot



CAPACITY

Series Assembly

Maximum Number of Units: 4

Air Capacity	US Gallons
1 Unit	1
2 Units	2
3 Units	3
4 Units	4

The P.A.P.A. is rated for 5 PSI

Weight: 5 pounds

In-Wall Access Box and Grill

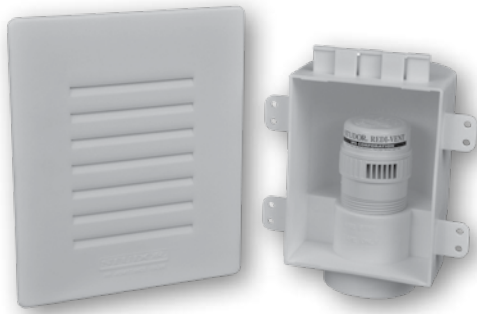
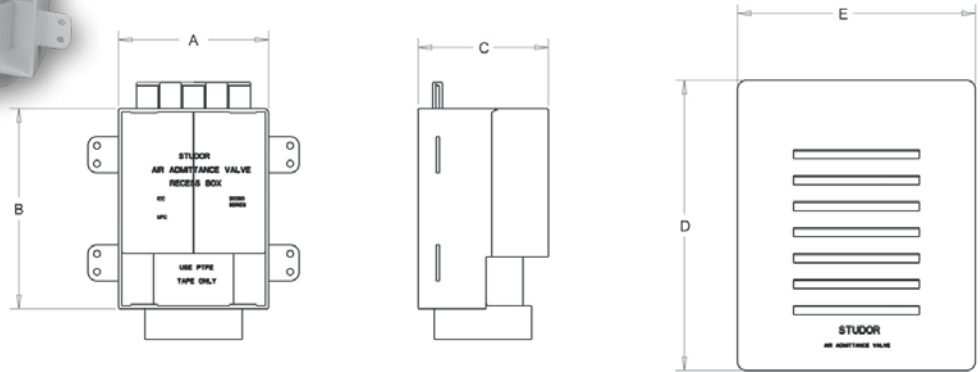

Figure 1

- Studor recess boxes and grills are ideally suited for in-wall installation and provides the required accessibility to the Mini-Vent®, Redi-Vent® or Tec-Vent®.



	A	B	C	D	E
Figure 1	4-1/8"	5-1/2"	3-5/8"	8"	6-5/8"
Figure 2	7-3/4"	7-3/4"	3-3/4"	9-1/2"	9-1/2"

Figure 2

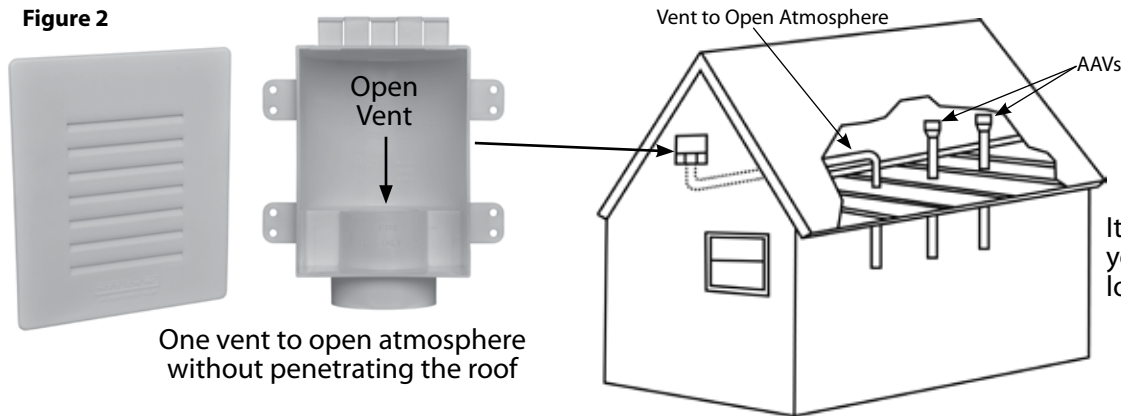

One vent to open atmosphere without penetrating the roof

It is recommended that you check with your local building official

"FR-12" Air Admittance Valve Recess Box



Fits: Mini-Vent®, Redi-Vent® and Tec-Vent®

- Warnock Hersey Certified
- 1-hour and 2-hour rated
- Made of high temperature resin
- U.L. Listed Intumescent Pad attached to back of outlet box

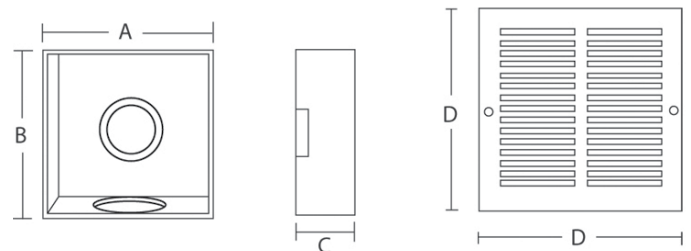

A	B	C	D
6"	6"	3-5/8"	9-1/2"

Roof Top Installation

Prevent unwanted sewer gas that lingers in the open atmosphere or enters the building through the air handlers.

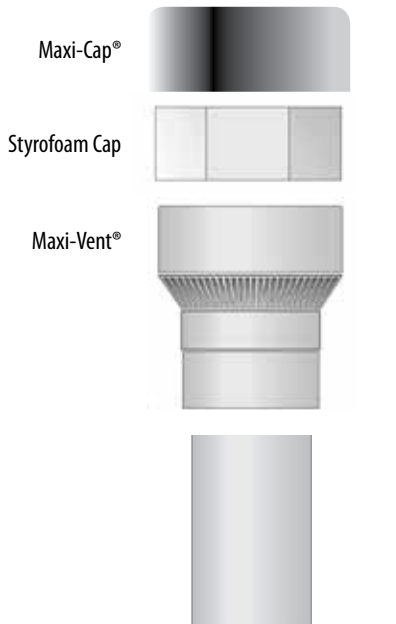

For 3" or 4" pipe use the Maxi-Vent® with Maxi-Cap®



For 1-1/2" or 2" pipe use the Mini-Vent® with cover

If there is only one vent to open atmosphere, we recommend the addition of the Maxi-Filtra®

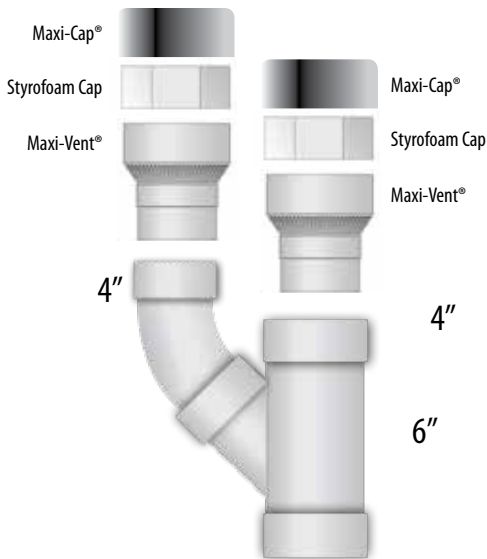
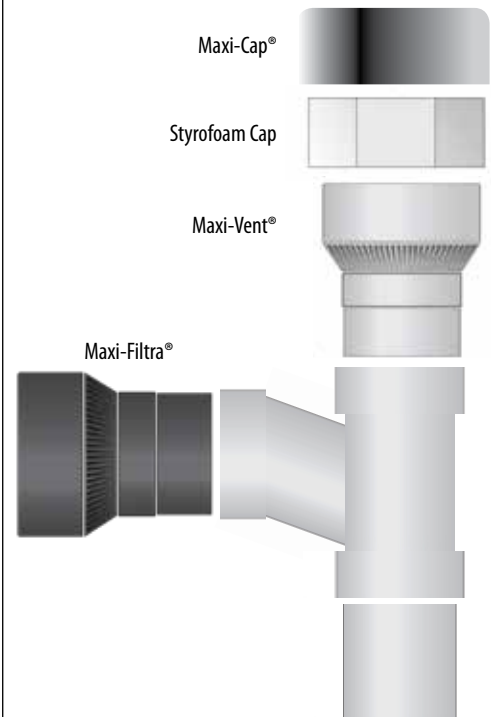

For 6" pipe use (2) Maxi-Vents® with Maxi-Caps®

**Note: For pipes larger than 6" notify Studor, Inc.
Note: Ensure that one open vent is maintained**

Replaceable cartridge will last up to two years

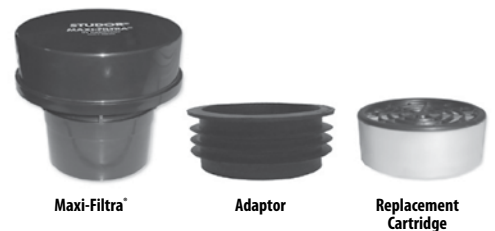

Maxi-Filtra® is for Outdoor use only

Introduction to Air Admittance Valves (AAVs)

The Difference

Air Admittance Valve (Code Compliant)



Natural Forces

Negative Pressure (opens)

- It is designed to open when a fixture is discharging to allow air to enter the system.

Gravity (closes)

- It is designed to close by gravity when there is no flow in the system to prevent the escape of sewer gas into the building.
- This style air admittance valve is not recognized as a mechanical vent in the International Plumbing Code.

Cheater Vent (Noncompliant)

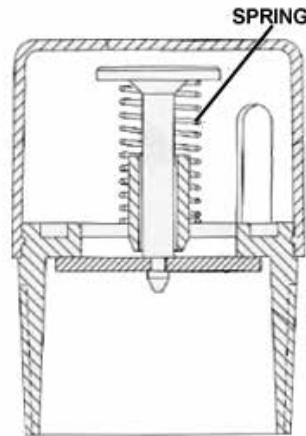

This old style valve is not legal and it does not meet the criteria nor is it recognized in any of the codes.

- There is a spring that opens and closes the seal which could lose tension, jam or break over time that allows sewer gases to enter the building.
- This style valve is recognized as a mechanical vent in the International Plumbing Code.

Introduction to Air Admittance Valves (AAVs)

Exclusive Design



Only Studor air admittance valves are designed with vermin protective screens both inside and outside to protect the seal and seat from insects, debris or foreign objects from entering the valve.



- The ribbed channels are beveled towards the center of the valve.
- Only Studor air admittance valves feature a special designed top that channels condensation away from the membrane.

Introduction to Air Admittance Valves (AAVs)

Dealing with Negative Air Pressure

The concept of venting fixtures has been a part of the plumbing industry since its conception. Balancing the pressure inside a DWV system, in order to equalize it with ambient pressure, is essential to maintain the water seal in the fixture trap. Loss of the water seal would allow the introduction of contaminants (sewer gasses and pathogens) into the living space.

Lacking the insight of modern science and the aid of modern technology, early designers devised a system comprised of a series of pipes extending to the outdoors. Although with updates and variation that very same cumbersome and often slow reacting system is still very much in use today around the world. It wasn't long, however, before the limitations of such a design were evident (e.g. roof penetrations and all related problems, excessive material use, space limitations, frost closure, trap loss due to high wind conditions, chimney effect in the pipe during fires, etc.).

Attempts were made to find more practical and effective solutions but lack of reliability and or the inability to maintain a healthy and sanitary environment doomed most of these efforts.

Studor Air Admittance Valves were the first devices to offer an alternative to open pipe vent systems. STUDOR's design utilizes a reverse lift sealing mechanism (membrane) which opens (**Fig. 1**) when even minimal vacuum conditions are present inside the system and closes (by gravity) when external and internal pressures are equalized. With the OPEN and CLOSED control functions entirely by pressure changes in the system and gravity, STUDOR AAVs have no springs (that can rust or lose memory), no gears (to jam or wear) and no stress components or dynamic seals (to fail). Additionally, any positive pressure, like sewer gasses trying to escape, causes the valve to seal even tighter (**Fig. 2**). The result is a valve which far exceeds the life of the system it serves to maintain proper sanitation.

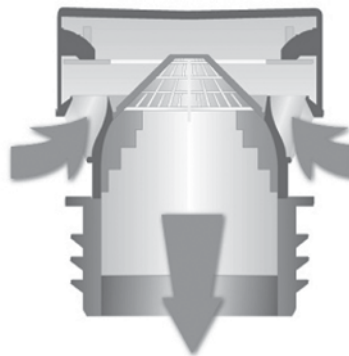

Fig. 1



Fig. 2

Besides working flawlessly, representing potential savings (by eliminating unnecessary vent piping and roof penetrations) and being the best solution for difficult to vent fixtures, STUDOR AAVs bring to a DWV system perhaps the most important of all features: greater efficiency.

Because AAVs are either at or very near the Point Of Need (PON) for air, and thanks to their reaction times, a system utilizing STUDOR AAVs is capable of balancing its internal pressure much more efficiently, without trap movement or depletion than open pipe vent systems. This is particularly true in large commercial applications where the air needed to balance the system after each occurrence is drawn from far away points and thus require substantial time to reach the Point Of Need (PON).

Air Admittance Valve Installation Criteria

1. STUDOR AAVs must be located a minimum of four (4") inches above the horizontal branch drain or fixture drain being vented.
2. STUDOR AAVs shall be accessible should replacement be required. For in-wall installation, use STUDOR recess box/grill combination.
3. STUDOR AAVs location must allow for adequate air to enter the valve. When located in a wall space or attic space lacking ventilation openings, opening shall be provided. Locating the valve in a sink or vanity cabinet is acceptable.
4. STUDOR AAVs must be installed in the vertical, upright position. A maximum deviation (in either direction) for plum of 15 degrees is allowed.
5. The vent shall connect to the drain vertically to maintain an unobstructed opening in the piping to the STUDOR AAVs.
6. A minimum of one vent pipe shall extended to the open atmosphere for each building drainage system for relief of positive pressure, the size of this vent is not specified because this single vent does not determine the total amount of aggregate cross-sectional area of the vent system. The total amount of the cross-sectional area of vents combined on the system has to equal the aggregate cross-sectional area of the building drain. When properly installed an air admittance valve in the system is equivalent to an open vent pipe having the same cross sectional area as any other vent. Such open air vent is recommended, not required, to be located as close as possible to the connection between the building drain and building sewer.
7. The Maxi-Vent® must be installed six (6") inches above the highest flood level rim of the fixtures being vented in stack applications.
8. STUDOR AAVs installed in attic area must be located a minimum of six (6") inches above the ceiling insulation.
9. The use of Tec-Vent® in return air plenums shall be allowed only in engineered drainage systems designed by a design professional and approved by the local authority.
10. The maximum height of drainage stack being vented by a MAXI-VENT must not exceed six (6) branch intervals unless it is used in conjunction with a stack that is connected to a P.A.P.A. and AAVs on the branches.
11. When a horizontal branch connects to a stack more than four (4) branch intervals from the top of the stack. A relief vent shall be provided. The relief vent must be located between the connection of the branch to the stack and the first fixture connecting to the branch. The relief vent may also serve as a vent for the fixture. The relief vent must connect to the vent stack, stack vent or extend outdoors to the open air unless it is used in conjunction with a stack that is connected to a P.A.P.A. device and AAVs on the branches.
12. Only Teflon® tape can be used on the valves' threads. Use of primer, solvent cement or pipe dope will void the STUDOR warranty.
13. The Redi-Vent®, Mini-Vent®, Maxi-Vent®, Tec-Vent® and Chem-Vent® must be installed at finish, after the system rough-in and pressure test.
14. Air Admittance Valves may be used on grease traps as long as they are not subject to positive pressure.

Installation Design Criteria of AAVs

Air Admittance Systems Design Criteria

There are ever several additional designs are also acceptable.

INDIVIDUAL VENT

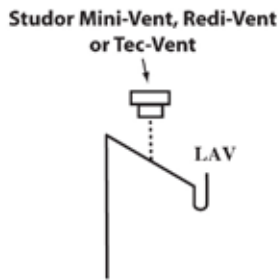

Figure 1

The simplest form of venting is an individual vent. The individual vent with the Studor vent as the vent terminal is an effective method of venting island fixtures or fixture located in a remote location.

COMMON VENT

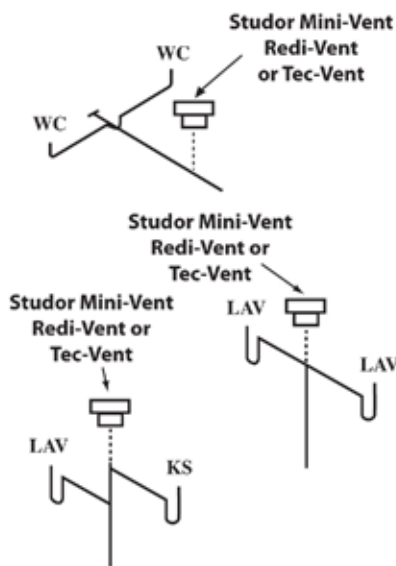

Figure 2

The common vent is similar to an individual vent. The vent serves two or three fixtures. The Studor vent can be located in the close proximity to the fixture being vented.

WET VENT

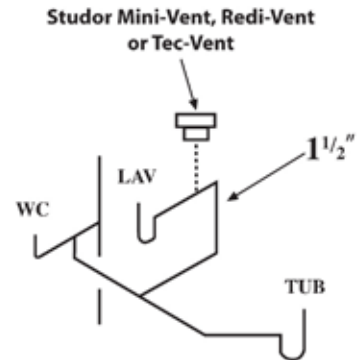

Figure 3

A wet vent is a single vent for one or two bathroom groups. There are different layouts for achieving the same venting concept. A single bathroom group wet vent can terminate to a Studor Vent.

WET VENT

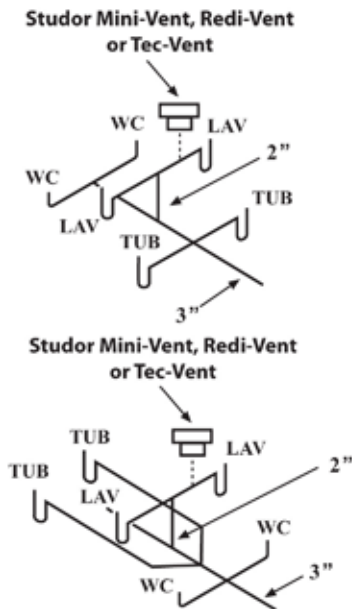

Figure 4

A double bathroom group, back to back, can be wet vented with a single Studor vent connecting as the vent.

CIRCUIT VENT

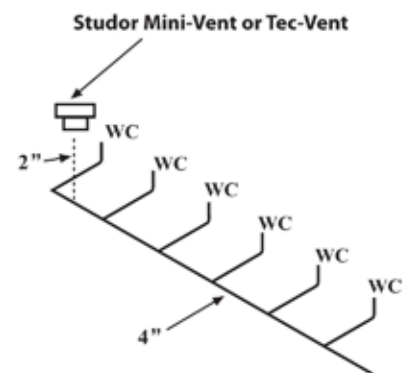

Figure 5

A single vent serves as the vent for three to eight fixtures. The Studor vent serves as the circuit vent.

Installation Design Criteria of AAVs

CIRCUIT VENT

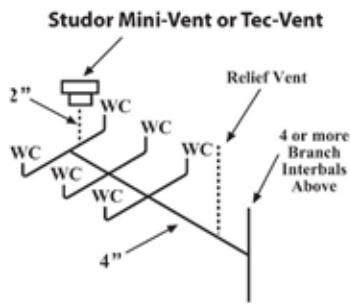

Figure 6

When the horizontal drainage branch connects to a stack having more than 4 branch intervals located above the branch, a relief vent is required. The relief vent must connect to the vent stack, stack vent, or extend to the outdoor air

BRANCH VENT

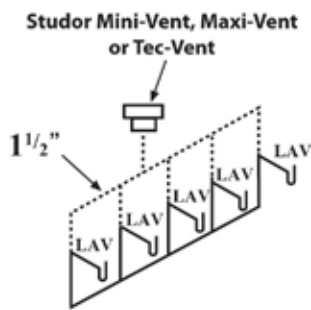

Figure 7

When various vents connect to a branch vent a Studor vent can serve as the vent for the branch

BRANCH VENT

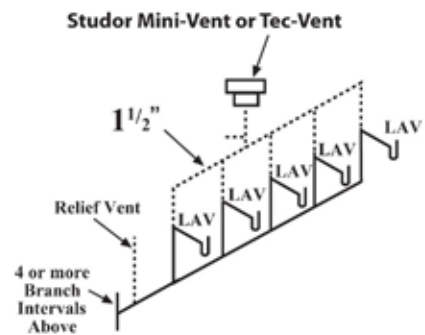

Figure 8

More than one Studor vent can be installed within a horizontal branch to vent various fixtures. A relief vent is required when more than 4 branch intervals are located above the branch connection.

VENT STACK - STACK VENT

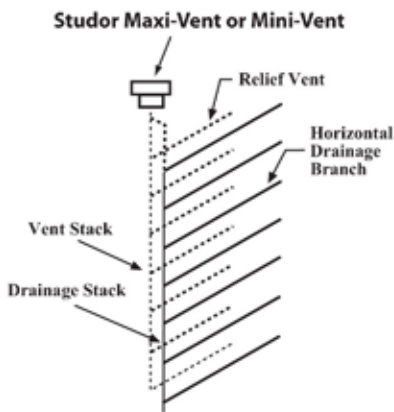

Figure 9

The stack type air admittance valve, Studor vent can serve as the vent for a vent stack or stack vent. The maximum height of the drainage stack that is vented with an air admittance valve is six branch intervals

WASTE STACK VENT

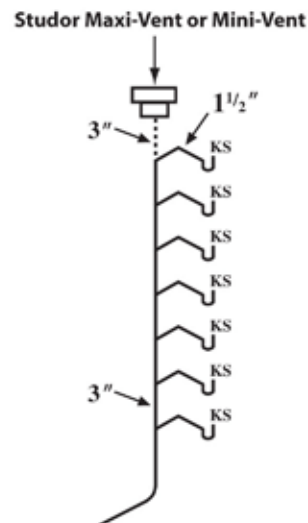

Figure 10

The Studor vent can serve as the vent for a waste stack vent. The maximum height of the waste stack vent with an air admittance valve is six branch intervals

Installation Design Criteria of AAVs

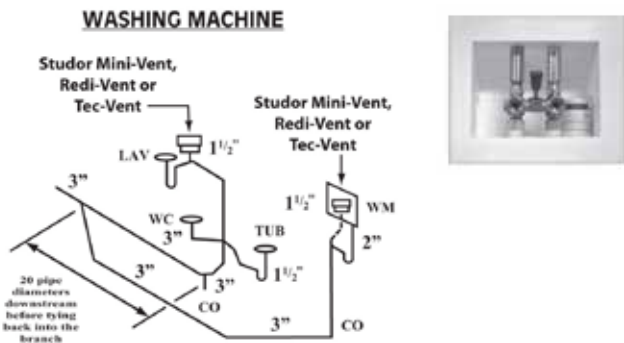
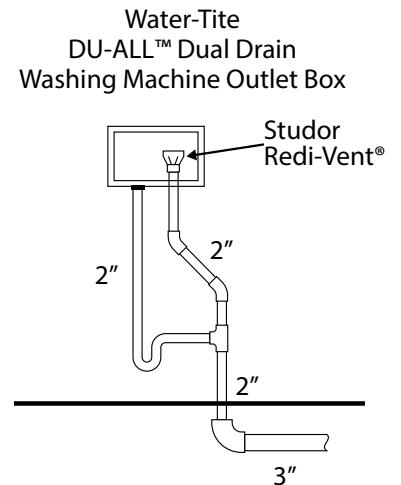

Figure 11

The IPC and the IRC both would show that Air Admittance Valves are permitted for the use of individual vents, branch vents and circuit vents. The Studor MINI-VENT or REDI-VENT may serve as the termination point for these vents as long as there is at a minimum of one vent to open atmosphere within the building system. There are no stipulations within the code that precludes our product from being used in this manner. Studor endorses the IPC code which recommends that the horizontal line from the washing machine be 3" as the standard for the DWV system when installing washing machine drains. The IRC use of a 2" horizontal line does not in any way preclude us from being used as a termination point for the vent.

DU-All™ Dual-Drain Washing Machine Outlet Boxes

- Fits Mini-Vent, Redi-Vent or Tec-Vent



Refer to the IPS Catalog for the different variations and connections

MultiBox™ System

- Refer to the IPS Catalog for the MultiBox™ System part numbers
- MultiBox™ System is also available in Fire-Rated
- MultiBox™ fits Redi-Vent only

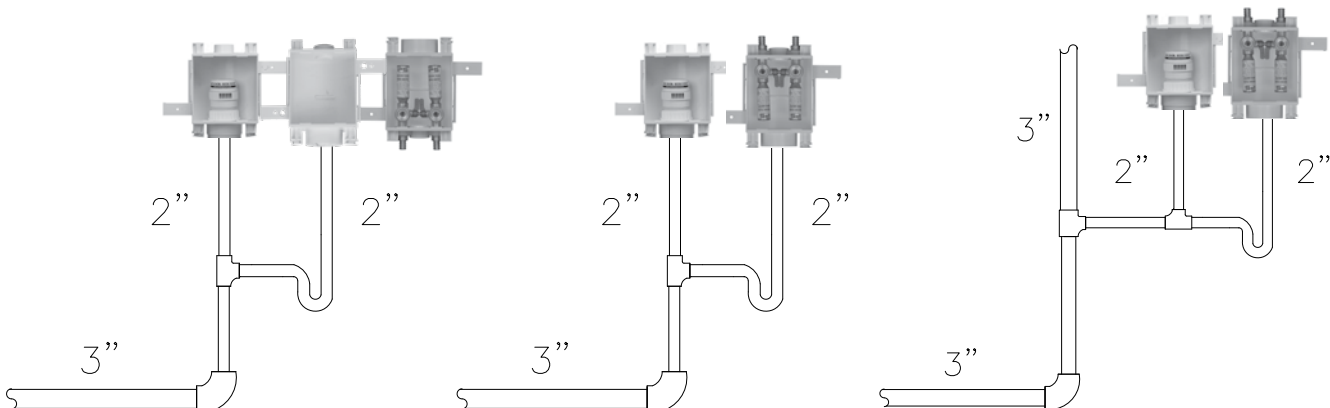
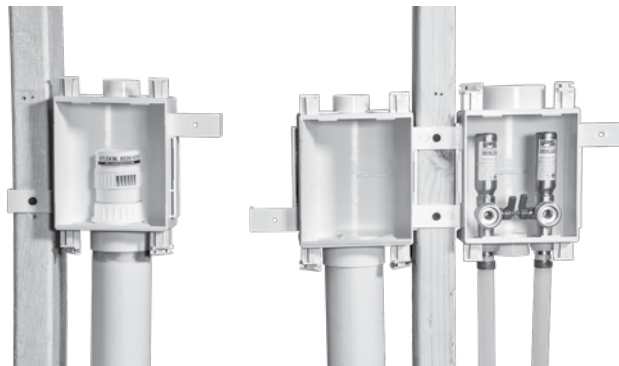

Installation Design Criteria of AAVs

Air Admittance Systems Design Criteria (cont)

Any combination of fixtures within two bathroom groups located on the same floor level are permitted to be vented by a wet vent.

A bathroom group is defined as a group of fixtures consisting of a water closet, lavatory, bathroom or shower including or excluding a bidet, an emergency floor drain or both and such fixtures are located together on the same floor.

The piping arrangement in the wet vent system permits the designer and installer the versatility to combine the fixtures with a single vent pipe connection.

Horizontal Wet Vent

Shaded area designates Wet vent

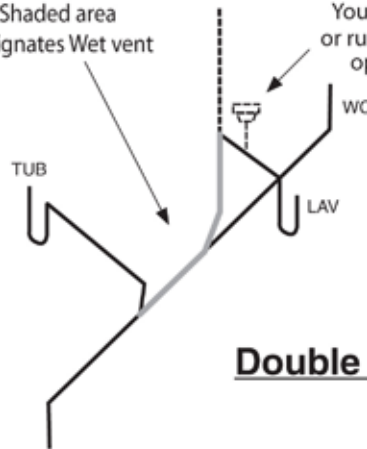

NOTE:

You can install an AAV or run a vent pipe to the open atmosphere.

The wet vent shall be considered the vent fixtures and shall extend from the connection of the dry vent along the direction of flow in the drain pipe to the most downstream fixture drain connection to the horizontal branch.

Horizontal Wet Vent

Shaded area designates Wet vent

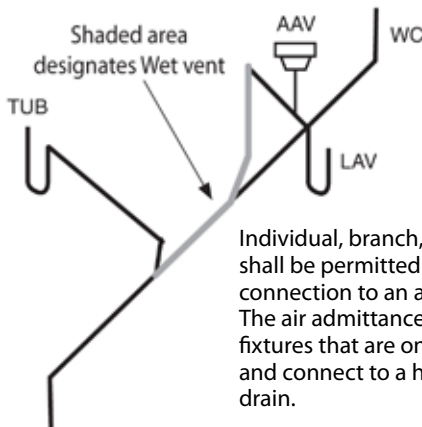

Individual, branch, and circuit vents shall be permitted to terminate with a connection to an air admittance valve. The air admittance valve shall only vent fixtures that are on the same floor level and connect to a horizontal branch drain.

Double Bathroom Group

NOTE:

You can install one AAV on either side of the lavatory branch arm

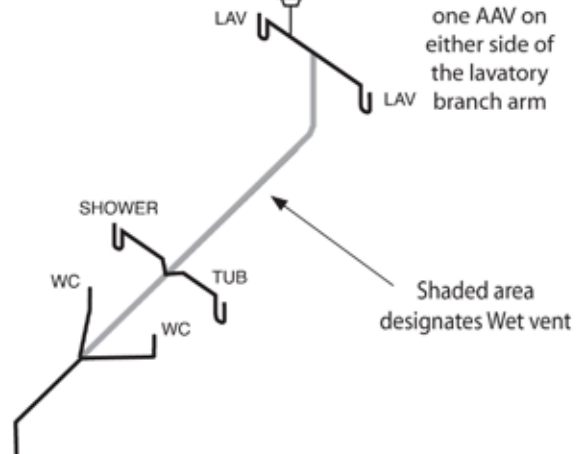

Shaded area designates Wet vent

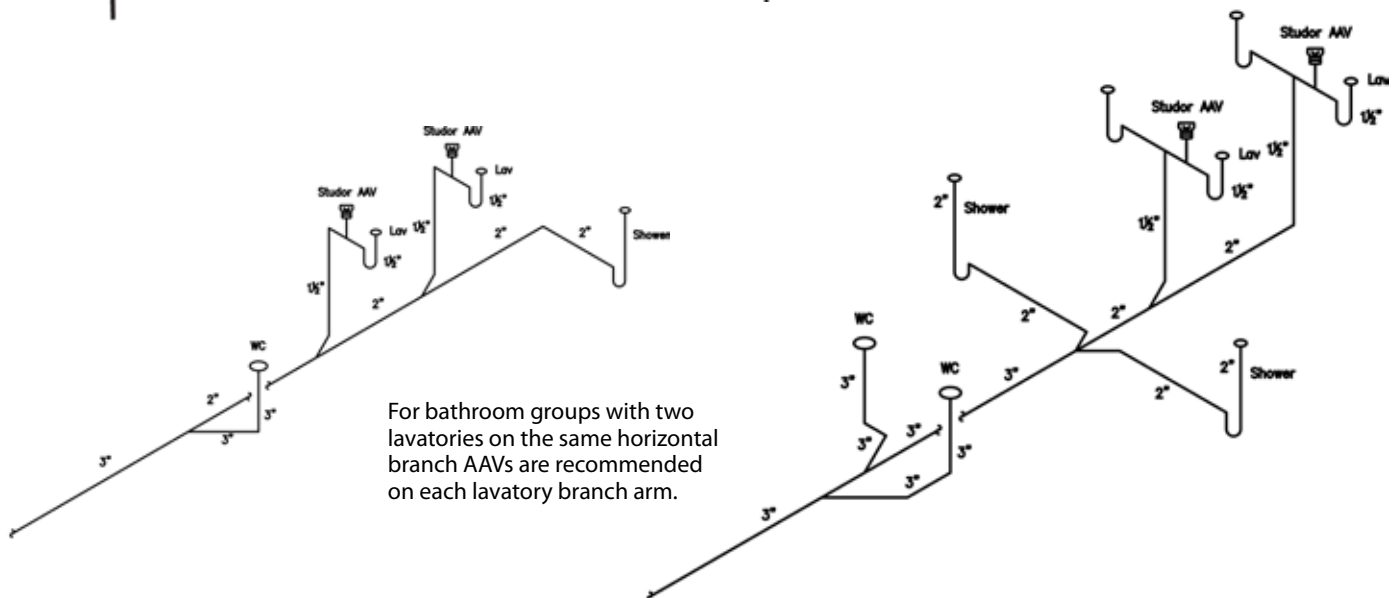

For bathroom groups with two lavatories on the same horizontal branch AAVs are recommended on each lavatory branch arm.

Installation Design Criteria of AAVs

Maximum Distance of Fixture Trap from Vent

Size of Trap (inches)	Slope (inches) per Foot	Distance from Trap (Feet)
1-1/4"	1/4"	5'
1-1/2"	1/4"	6'
2"	1/4"	8'
3"	1/8"	12'
4"	1/8"	16"

IPC Table 909.1 2015

Size of Trap (inches)	Slope (inches) per Foot	Distance from Trap (Feet)
1-1/4"	1/4"	2' - 6'
1-1/2"	1/4"	3' - 6'
2"	1/4"	5'
3"	1/4"	6'
4"	1/4"	10"

UPC Table 1002.2 2012

Sizing the Wet Vent and the Dry Vent

Shaded area designates Wet vent

NOTE: You can install one AAV or either side of the lavatory branch arm

Wet Vent Pipe Size (inches)	Drainage Fixture Unit Load (DFUs)
1-1/2"	1
2"	4
2-1/2"	6
3"	12

UPC - Refer to section 908.2 Horizontal Wet Venting for Bathroom Groups
Section 908.2 Size

IPC Table 912.3 Sizing the Wet Vent

Horizontal Wet Venting

NOTE: Only the fixtures within the bathroom group shall connect to the wet vented horizontal branch drain

NOTE: You can install an AAV or run a vent pipe to the open atmosphere

The distance from the vent to the trap weir of the bathtub is longer than 8' therefore an individual vent is required

NOTE: You can install one AAV or either side of the lavatory branch arm

NOTE: You can install one AAV on either side of the branch arm

NOTE: Not Allowed

Shaded area designates Wet vent

Any additional fixtures shall discharge downstream of the wet vent

Installation Design Criteria of AAVs

Stack discharge to horizontal wet vent is prohibited

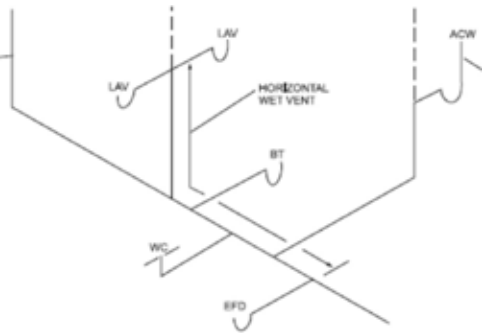

Non bathgroup fixture (Automatic clothes washer) discharge into horizontal wet vent is prohibited

Noncompliant Horizontal Wet Vent

IPC 2015 - Figure 912.1 (13)

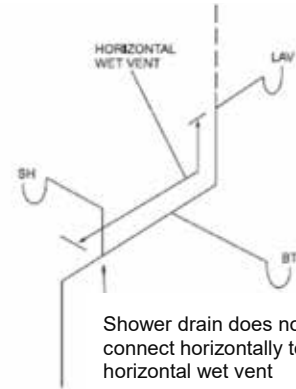

Shower drain does not connect horizontally to horizontal wet vent

Noncompliant Horizontal Wet Vent

IPC 2015 - Figure 912.1 (16)

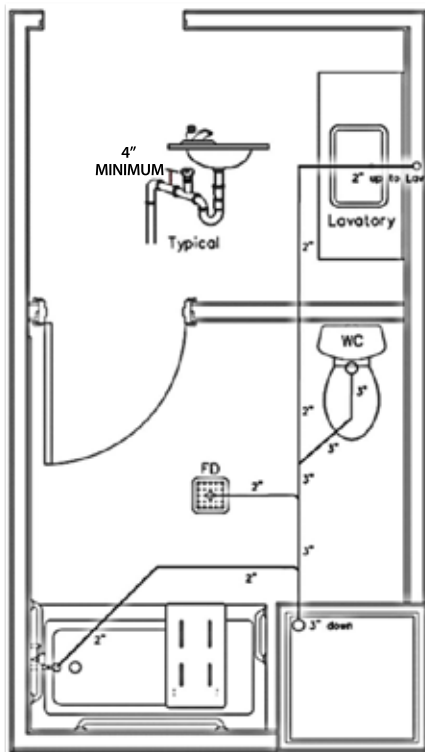

Code Compliant

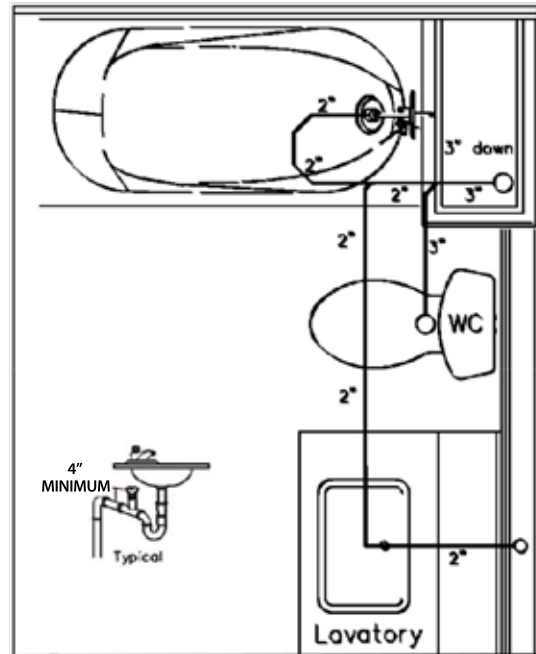

Code Compliant

IPC TABLE 909.1
Maximum Distance of Fixture Trap from

Size of Trap (inches)	Slope (inches) per Foot	Distance from Trap (Feet)
1-1/4"	1/4"	5'
1-1/2"	1/4"	6"
2"	1/4"	8"
3"	1/8"	12'
4"	1/8"	16"

Installation Design Criteria of AAVs

Drainage Fixture Units (DFU)

Drainage Fixture Unit is a value that is directly related to the sizing and selection of both your drainage piping and your Air Admittance Valves. Specifically when it comes to selecting the right Studor air admittance valve a capacity range which can vary substantially (e.g. from 1 DFUs to 500 DFUs). It is important to notice that this capacity range is not at all a function of the valve size but rather of the size of the branch serviced by the valve. The table below shows how DFUs values are assigned to different fixtures.

INTERNATIONAL PLUMBING CODE SECTION 709.1 FIXTURE TYPE	DRAINAGE FIXTURE UNIT VALUE AS LOAD FACTORS	MINIMUM SIZE OF TRAP (INCHES)
Automatic clothes washers, commercial ^{a,g}	3	2
Automatic clothes washers, residential ^g	2	2
Bathroom group as defined in Section 202 (1.6 gpf water closet) ^f	5	---
Bathroom group as defined in Section 202 (water closet flushing greater than 1.6 gpf) ^f	6	---
Bathtub ^b (with or without overhead shower or whirlpool attachments)	2	1 1/2
Bidet	1	1 1/4
Combination sink and tray	2	1 1/2
Dental lavatory	1	1 1/4
Dental unit or cuspidor	1	1 1/4
Dishwashing machine ^c , domestic	2	1 1/2
Drinking fountain	1/2	1 1/4
Emergency floor drain	0	2
Floor drains ^h	2 ^h	2
Floor sinks	Note h	2
Kitchen sink, domestic	2	1 1/2
Kitchen sink, domestic with food waste grinder and/or dishwasher	2	1 1/2
Laundry tray (1 or 2 compartments)	2	1 1/2
Lavatory	1	1 1/4
Shower (based on the total flow rate through showerheads and body sprays) Flow rate: $\sum V$		
• 5.7 gpm or less	2	1 1/2
• Greater than 5.7 gpm to 12.3 gpm	3	2
• Greater than 12.3 gpm to 25.8 gpm	5	3
• Greater than 25.8 gpm to 55.6 gpm	6	4
Service sink	2	1 1/2
Sink	2	1 1/2
Urinal	4	Note d
Urinal, 1 gallon per flush or less	2 ^e	Note d
Urinal, nonwater supplied	1/2	Note d
Wash sink (circular or multiple) each set of faucets	2	1 1/2
Water closet, flushometer tank, public or private	4 ^e	Note d
Water closet, private (1.6 gpf)	3 ^e	Note d
Water closet, private (flushing greater than 1.6 gpf)	4 ^e	Note d
Water closet, public (1.6 gpf)	4 ^e	Note d
Water closet, public (flushing greater than 1.6 gpf)	6 ^e	Note d

a. For traps larger than 3 inches, use Table 709.2.

b. A showerhead over a bathtub or whirlpool bathtub attachment does not increase the drainage fixture unit value.

c. See Sections 709.2 through 709.4.1 for methods of computing unit value of fixtures not listed in this table or for rating of devices with intermittent flows.

d. Trap size shall be consistent with the fixture outlet size.

e. For purpose of computing loads on building drains & sewers, water closets & urinals shall not be rated at a lower drainage fixture unit unless the lower values are confirmed by testing.

f. For fixtures added to a bathroom group, add the dfu value of those additional fixtures to the bathroom group fixture count.

g. See Section 406.3 for sizing requirements for fixture drain, branch drain, and drainage stack for an automatic clothes washer standpipe.

h. See Sections 709.4 and 709.4.1.

Air Admittance Valve Installation

Studor Mini-Vent or Redi-Vent

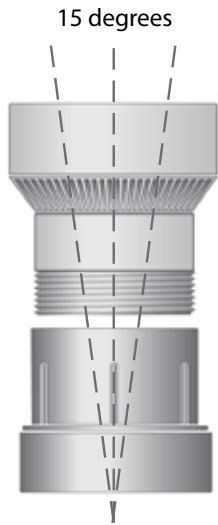

15 degrees

The maximum offset from vertical position is 15 degrees

Studor AAVs must be installed in the upright position

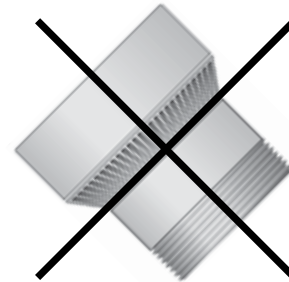

Protective Cover

When installing the Mini-Vent outdoors, use the protective cover

- First cement the adaptor
- Use Teflon Tape on the threads
- Do not use pipe dope
- Hand tighten valve to adaptor



Mini-Vent

Adaptor fits 1-1/2" or 2"



Redi-Vent

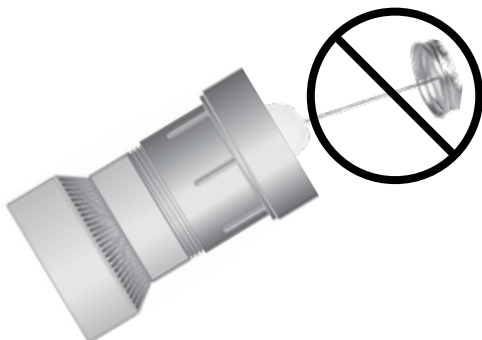
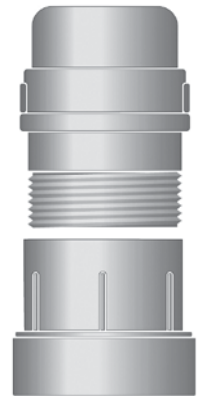

Do not cement adaptor when attached to the valve.

Cement will run down into the valve and compromise the seal.

Air Admittance Valve Installation

Maxi-Cap



Styrofoam Cover



Studor Maxi-Vent

When installing the Maxi-Vent outdoors, use the Maxi-Cap and Styrofoam cover

Maxi-Vent

When installing the Maxi-Vent on a 3" pipe, use a no-hub band or a banded rubber coupling.

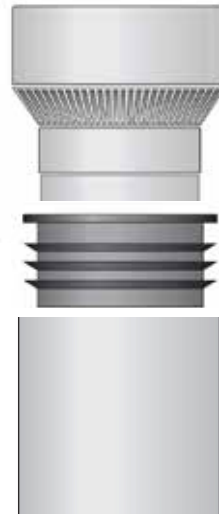

Maxi-Vent

When installing the Maxi-Vent on a 4" pipe, use the 4" push fit connector. The push fit connector goes inside the 4" pipe and the Maxi-Vent slips into the connector.

Do not cement a 3" coupling to attach the Maxi-Vent to the pipe

Studor Tech-Vent



The Tec-Vent fits 1-1/2" pipe size. When installing, use Teflon tape on threads and hand tighten to adaptor.

Note: The adaptor is not included.

Studor Chem-Vent



The extended 1- 1/2" schedule 40 spigot connection allows direct mount on any acid waste system (Mechanical Joint or Fusion) as well as CPVC glass or Duriron system with adaptor.

Studor Drawings (Utilizing Air Admittance Valves)

Island Sink Application

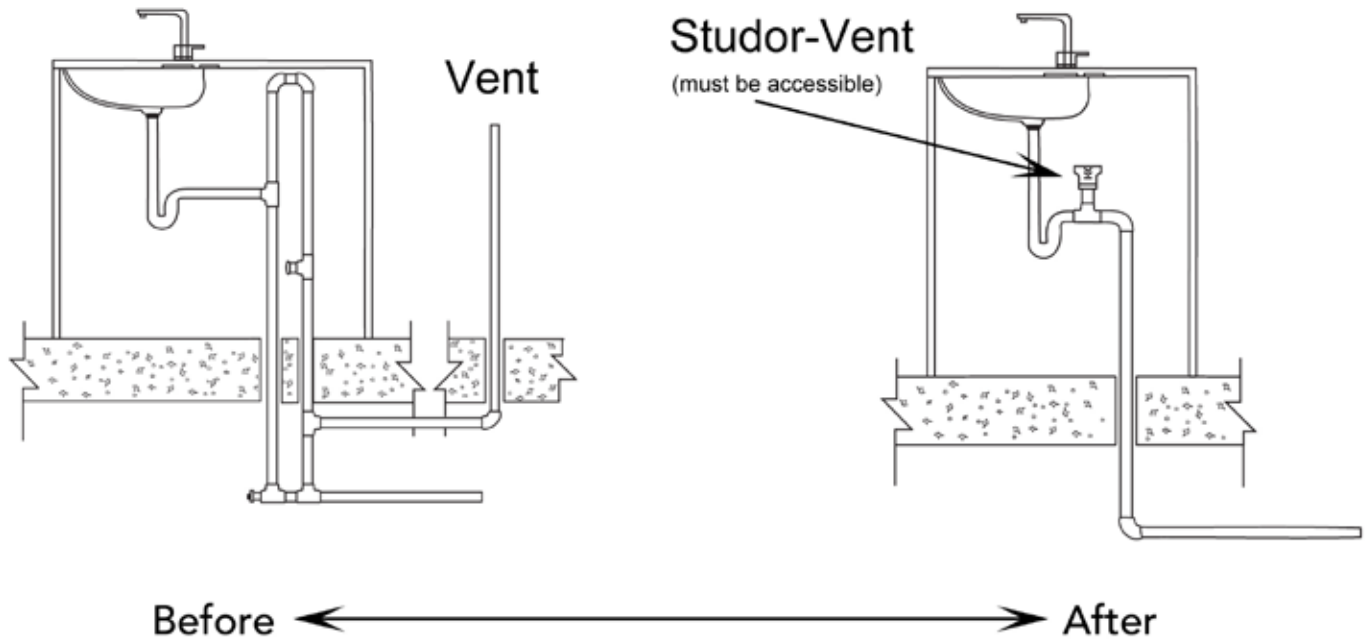

Washing Machine Application

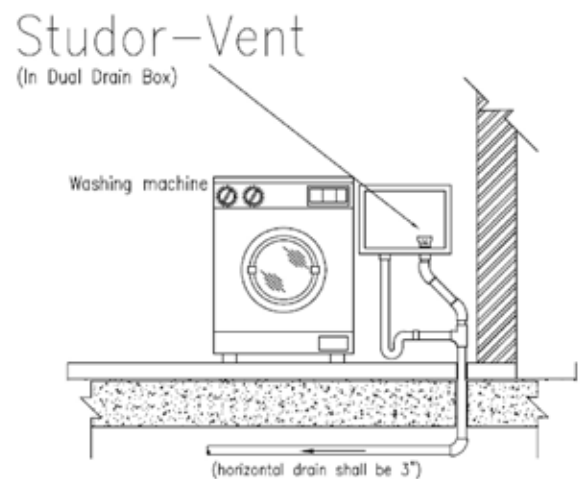
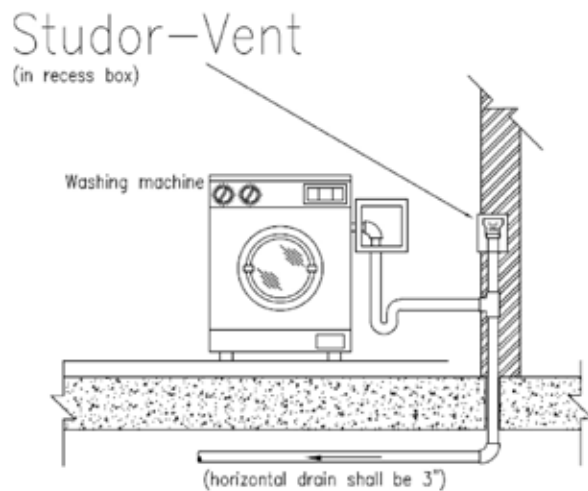

Studor Drawings (Utilizing Air Admittance Valves)

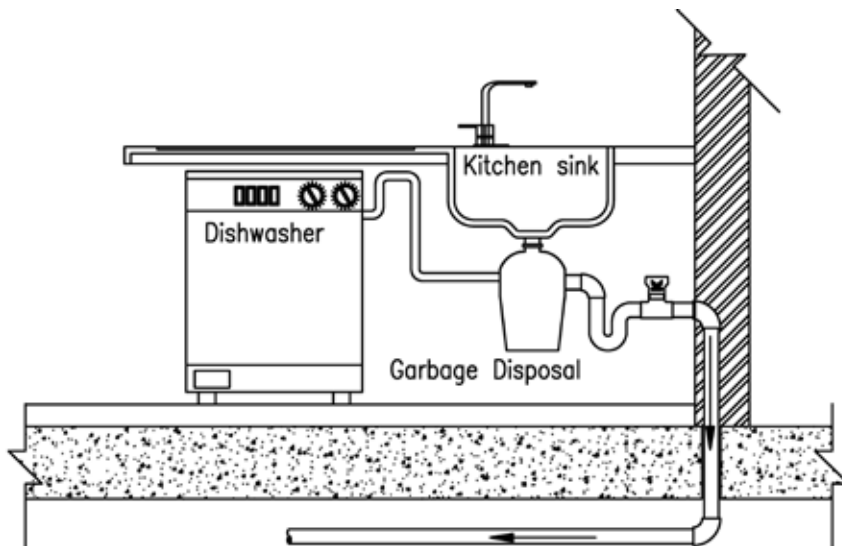
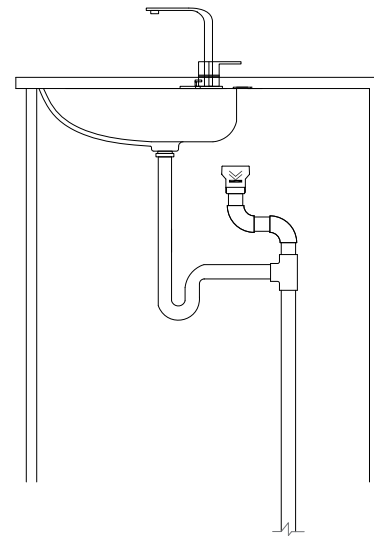
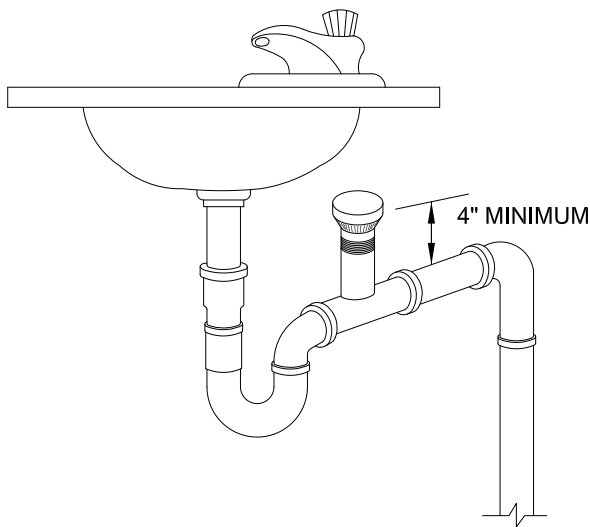
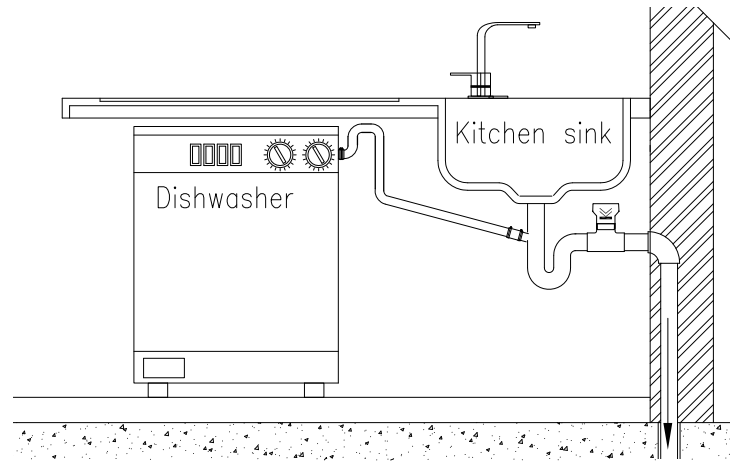
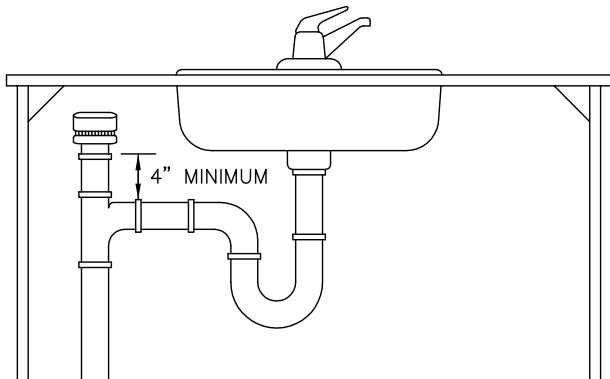

The American Society of Plumbing Engineers Research Foundation, Inc. published a report on the "Impact of Food Waste Disposers on Combination Waste and Vent Systems and Individual Vents Terminating to an Air Admittance Valve." In conclusion: The installation and operation of food waste disposers in combined waste and vent systems in either a domestic or commercial piping system produce no compromise of adjacent trap seals or venting functions. This is true in open venting and AAV venting systems.

Studor Drawings (Utilizing Air Admittance Valves)

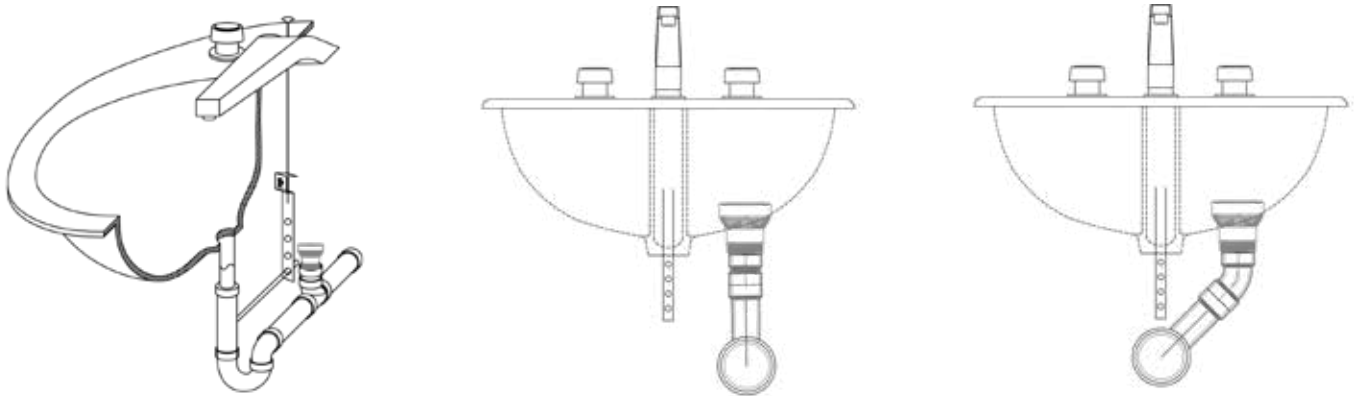

Offset drain waste to avoid conflict between Studor AAV and pop-up drainage linkage

Lavatory Application

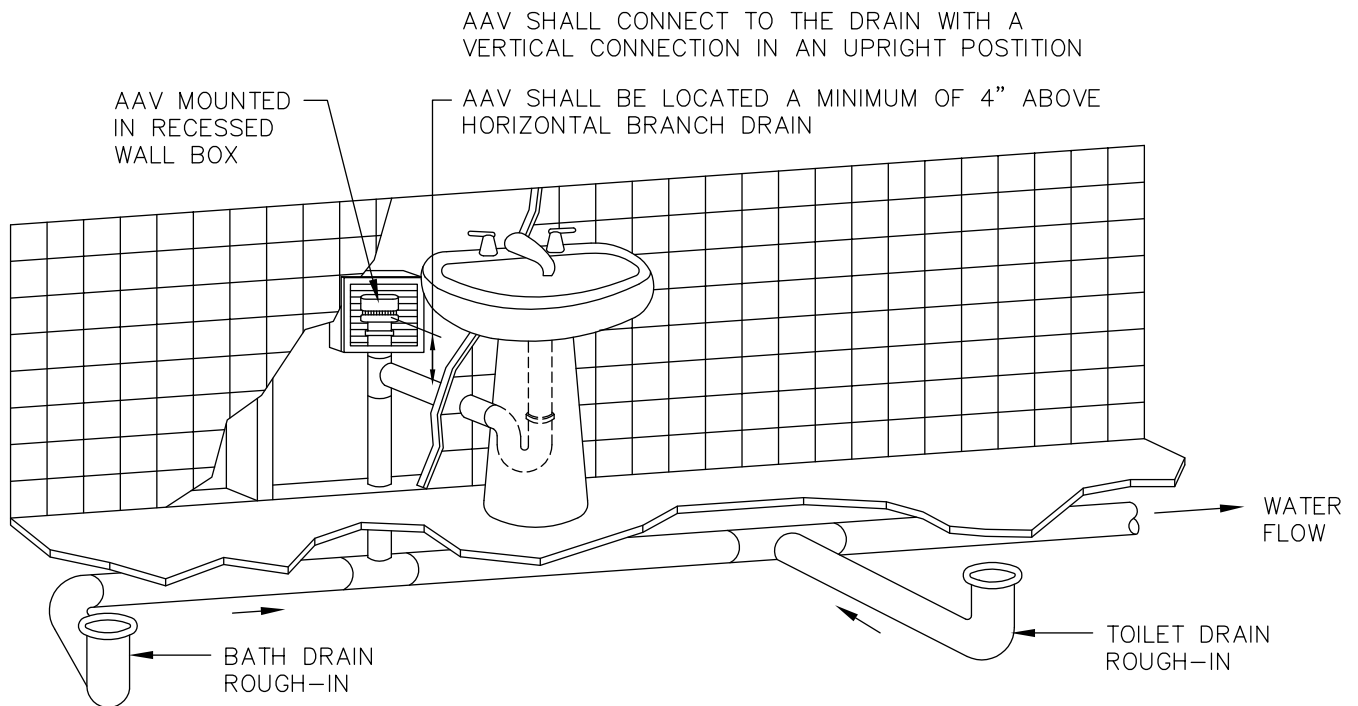

Studor Drawings (Utilizing Air Admittance Valves)

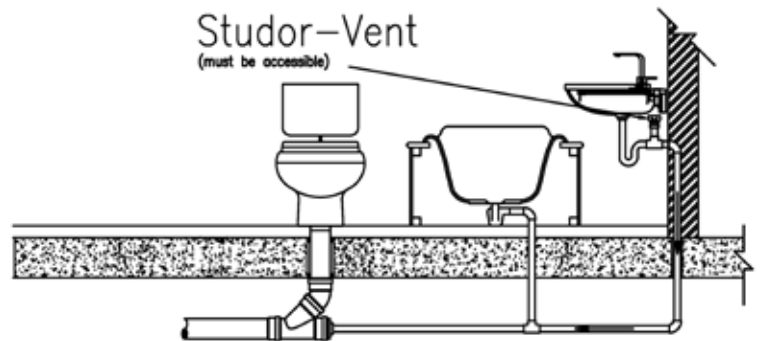
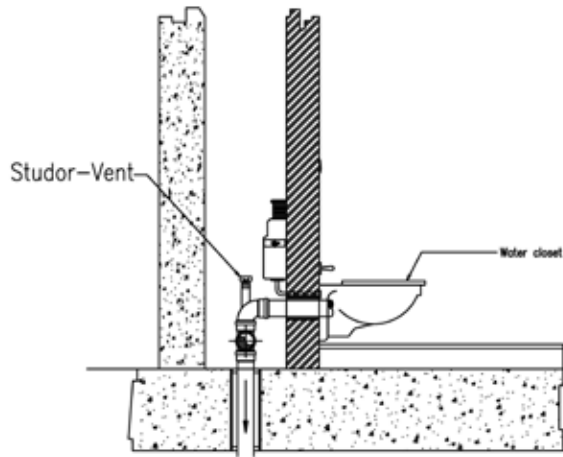
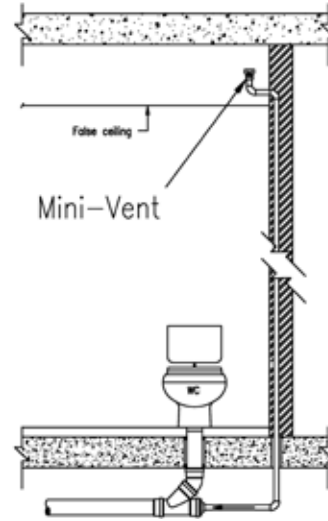
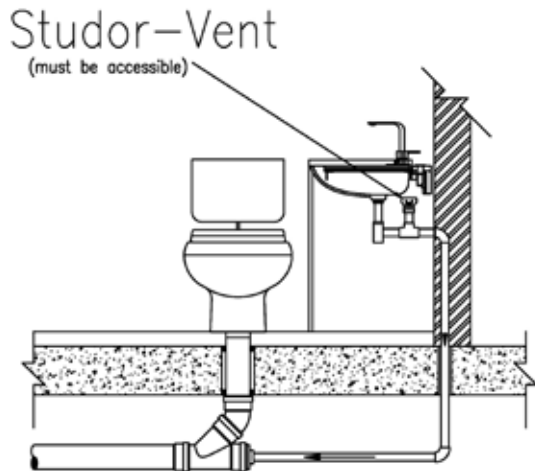

Terminating a waste stack on a Studor Single pipe system utilizing air admittance valves and P.A.P.A. devices.

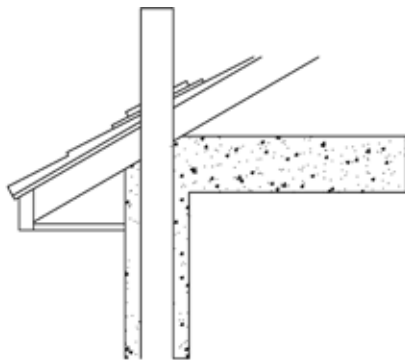

Terminating to open atmosphere

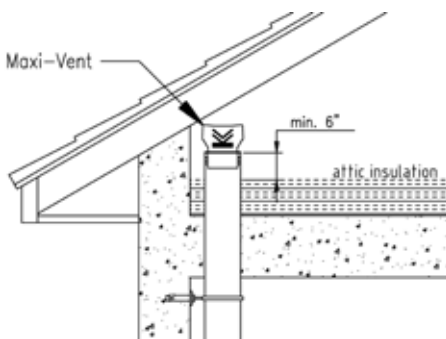

Terminating to an attic space

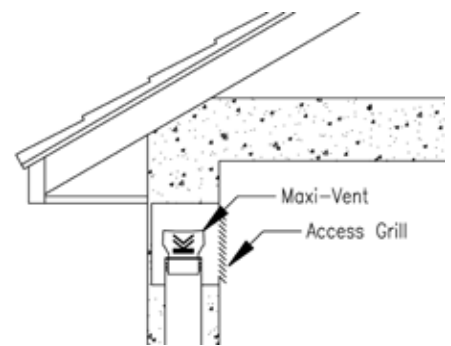

Terminating into a wall

A minimum of one vent pipe shall extended to the open atmosphere for each building drainage system.

Studor Drawings (Utilizing Air Admittance Valves)

Grease Trap

Studor Mini-Vent

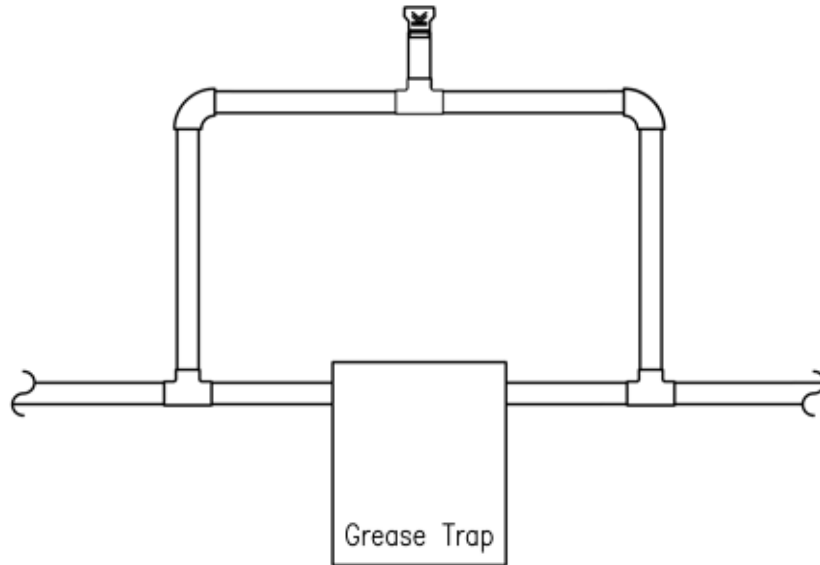

Sewer Ejector

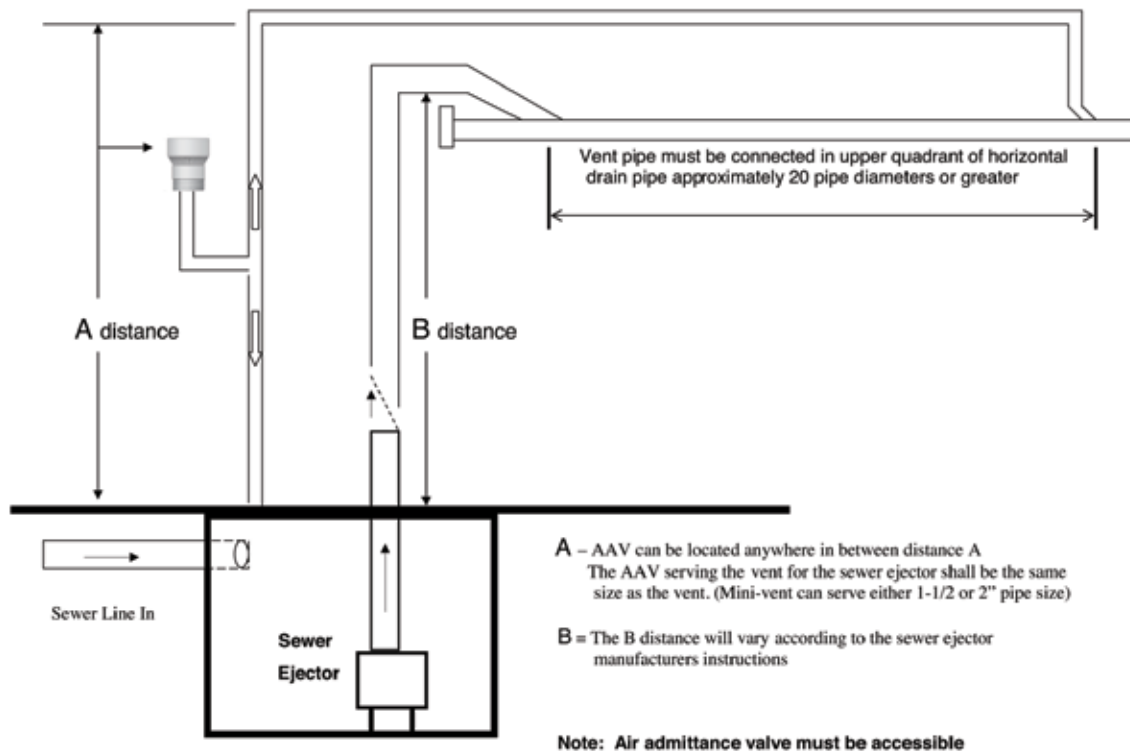

Standards & Listings - Air Admittance Valves

AIR ADMITTANCE VALVES Standards are the industry's benchmark for any given product. A standard will identify the minimum performance criteria of a product. Being the inventor of the Air Admittance Valve's exclusive technology, STUDOR was also instrumental, working closely with ASSE, in the development of today's applicable standards.

All STUDOR Air Admittance Valves are tested to and conform to the following standards:

- ANSI/ASSE 1051 (2009 revision) Single Fixture and Branch-Type AAVs
- ANSI/ASSE 1050 (2009 revision) Stack-Type AAVs
- ASSE Seal of Approval
- NSF Standard 14 (Plastic Pipe, Fittings and Components)

The fundamental technical parameter of ASSE 1051 and 1050 as they relate to the performance of AAVs as follows:

Minimum opening pressure	0.30 inches H₂O
Tightness	Tight at 0.25 inches of water column
Max pressure rating	30" H₂O
Endurance	500,000 cycles
Operating temperature range	-40F to +150F
Chem-Vent	-40F to +212F
Temperature test	8 hrs @ +150F
.....	8 hrs @ -40F

It is important to note that all STUDOR valves not only meet all but also exceed one or more of the above parameters. At 1,500,000 cycles all our valves far exceed the cycle life testing and some (like the Chem-Vent) undergo a much more stringent temperature test (8 hrs @ +212F) because of the potential of exothermic reaction in acid waste systems.

Product listings are also a fundamental part of a product makeup. Without listing there would be no independent third party certification that a given product actually conforms to the relevant standard(s).

All STUDOR Air Admittance Valves are listed and certified by one or more of the following:

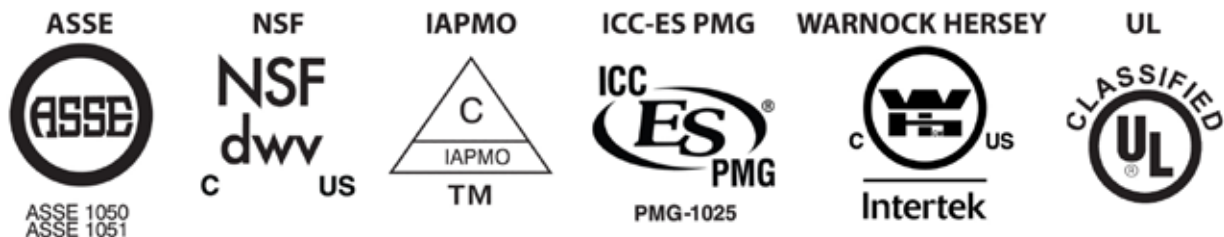

The Following is NSF14 Schedule for Testing STUDOR AAVs Air Admittance Valve Test Frequency

Test	Stack Type Devices	Fixture and Branch Devices
Capacity Test	Annually	Annually
Low Pressure Test of Complete Device	Weekly	--
Pressure Test of Complete Device	--	Weekly
Temperature Range Test	Annually	Annually
Thread Length	Weekly	Weekly
Product Standards	ASSE 1050	ASSE 1051

Note: Each Studor valve is tested at the factory and also tested by an independent third party as shown in the above schedule. After the Studor valve has been installed according to the manufacturer's instructions there is no further testing or maintenance required.

Codes

Currently there are several plumbing codes used in North America; the International Plumbing Code (IPC), the Residential Plumbing Code (IRC), the Uniform Plumbing Code (UPC), the National Standard Plumbing Code (NSPC) and the National Plumbing Code of Canada. There are also many State and local codes as well as variations of these model codes. Studor recommends you check with the local code authorities for up-dated changes.

2015 INTERNATIONAL PLUMBING CODE SECTION 918 AIR ADMITTANCE VALVES

918.1 General.

Vent systems utilizing air admittance valves shall comply with this section. Stack-type air admittance valves shall conform to ASSE 1050. Individual and branch-type air admittance valves shall conform to ASSE 1051.

918.2 Installation.

The valves shall be installed in accordance with the requirements of this section and the manufacturer's installation instructions. Air admittance valves shall be installed after the DWV testing required by Section 312.2 or 312.3 has been performed.

918.3 Where Permitted.

Individual, branch and circuit vents shall be permitted to terminate with a connection to an individual or branch-type air admittance valve in accordance with Section 918.3.1. Stack vents and vent stacks shall be permitted to terminate to stack-type air admittance valves in accordance with Section 918.3.2.

918.3.1 Horizontal Branches.

Individual and branch-type air admittance valves shall vent only fixtures that are on the same floor level and connect to a horizontal branch drain. Where the horizontal branch is located more than four branch intervals from the top of the stack, the horizontal branch shall be provided with a relief vent that shall connect to a vent stack or stack vent, or extend outdoors to the open air. The relief vent shall connect to the horizontal branch drain between the stack and the most downstream fixture drain connected to the horizontal branch drain. The relief vent shall be sized in accordance with Section 906.2 and installed in accordance with Section 905. The relief vent shall be permitted to serve as the vent for other fixtures.

918.3.2 Stack.

Stack-type air admittance valves shall be prohibited from serving as the vent terminal for vent stacks or stack vents that serve drainage stacks having more than six branch intervals.

918.4 Location.

Individual and branch-type air admittance valves shall be located a minimum of 4 inches (102 mm) above the horizontal branch drain or fixture drain being vented. Stack-type air admittance valves shall be located not less than 6 inches (152 mm) above the flood level rim of the highest fixture being vented. The air admittance valve shall be located within the maximum developed length permitted for the vent. The air admittance valve shall be installed not less than 6 inches (152 mm) above insulation materials.

918.5 Access and Ventilation.

Access shall be provided to all air admittance valves. The valve shall be located within a ventilated space that allows air to enter the valve.

918.6 Size.

The air admittance valve shall be rated in accordance with the standard for the size of the vent to which the valve is connected.

918.7 Vent Required.

Within each plumbing system, not less than one stack vent or vent stack shall extend outdoors to the open air.

918.8 Prohibited Installations.

Air admittance valves shall not be installed in non-neutralized special waste systems as described in Chapter 8 except where such valves are in compliance with ASSE 1049, are constructed of materials approved in accordance with Section 702.5 and are tested for chemical resistance in accordance with ASTM F 1412. Air admittance valves shall not be located in spaces utilized as supply or return air plenums. Air admittance valves without an engineered design shall not be utilized to vent sumps or tanks of any type.

Section 303 ... Materials.

303.3 Plastic Pipe, Fittings and Components. All plastic pipe, fittings and components shall be third-party certified as conforming to NSF-14

Section 406 ... Automatic Clothes Washers.

406.2 Waste Connection. The waste from an automatic clothes washer shall discharge through an air break into a standpipe in accordance with Section 802.4 or into a laundry sink. The trap and fixture drain for an automatic clothes washer standpipe shall be not less than 2 inches (51mm) in diameter. The fixture drain for the standpipe serving an automatic clothes washer shall connect to a 3-inch (76mm) or larger diameter fixture branch or stack. Automatic clothes washers that discharge by gravity shall be permitted to drain to a waste receptor or an approved trench drain.

IPC Section 912 ... Wet Venting.

UPC Section 902 ... Wet Venting.

Introduction to the P.A.P.A.[™] (Positive Air Pressure Attenuator)

Dealing with Positive Air Transients

We have seen how STUDOR AAVs are the technically preferable way of dealing with negative air pressure in a DWV system. We have also noted however how positive air pressure in the system will cause the valve to seal even tighter. This means that positive pressure in the system must be dealt with separately.

There are essentially three different types of positive pressure conditions in a DWV system:

Positive pressure from the main sewer (or septic tank) although positive pressure from the sewer or a septic tank is not a condition generated within your own system, it can certainly affect it in negative ways. For this reason it is important to have at least one open pipe vent per building drainage system. The drawings show two different layouts of a building complex. In the first example (**fig. 3**) the buildings only have one tie-in (thus requiring only one open vent) while the second example (**fig. 4**) shows two separate tie-ins (thus requiring two open vents in the building).

Positive Pressure Generated by a Blockage or Belly in the Pipe

This is clearly a condition requiring attention. Unlike with other kinds of positive pressure there are no devices or designs to address a blockage or belly in the pipe, this problem is a failure of the system and it must be fixed.

It is however important to understand how AAVs and a system utilizing AAVs are affected by such a condition. The first thing is to make sure the AAVs used are ASSE and NSF certified. Among other things this will guarantee that the valve will be able to withstand up to 30" of water column. Such products can be installed under the flood rim level since even in the presence of positive pressure created by a blockage (**fig. 5**) the valve(s) will not leak. Non third-party certified valves may not be able to handle the pressure generated by a blockage and should not be used.

Positive pressure building at the valve will prevent it from opening thus preventing sewer gases from entering the building. If we consider however that the blockage is a problem that must be fixed, a poorly draining fixture in a system utilizing AAVs acts as an early warning sign of a drainage problem allowing the user to address it in a timely fashion.

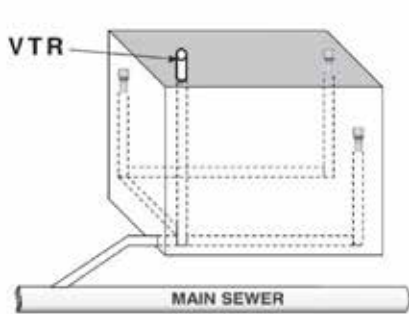

Fig. 3

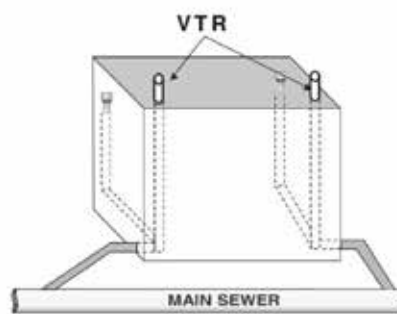

Fig. 4

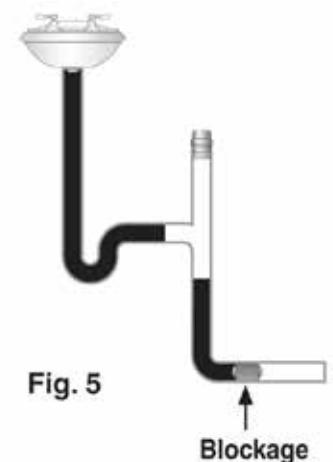

Fig. 5

Note: Within each plumbing system a minimum of one stack vent or vent stack shall extend outdoors to open air. The stack vent or vent stack may be located anywhere within the system as long as it extends outdoors to open air.

Positive Pressure Created by a Hydraulic Jump in Multi-Story Buildings

This pressure (referred to as positive transients) was believed to be the result of the hydraulic jump. Recent studies however have revealed a different scenario. When a WC is flushed or a bath or lavatory is emptied, the water flows in the horizontal part of the drainage system and carries with it solids from the WC or perhaps solids which had deposited in the pipe from a previous flush. When this water reaches a vertical stack pipe it pours in, in a curved fashion until it strikes the back wall of the vertical pipe. The water then swirls around the inner surface and falls down the pipe, under gravity, clinging to the pipe wall. This is called annular water flow (see figure 6). The water film on the inner surface of the pipe is surprisingly thin, even at high flow rates producing little more than 1/4 inch film thickness. The solids fall, under gravity, in the core of the pipe. At the bottom of the stack the piping system makes the transition from vertical to horizontal through a sweep. As the flow goes through the sweep, centrifugal forces generated by the swirling action keep the fluid attached to its ID, much the same way it did while falling through the vertical stack. Towards the end of the sweep however, the gravitational pull exceeds the centrifugal force and the fluid coating the inside of the sweep and upper half of the horizontal pipe falls to the bottom of the pipe forming a curtain of water. It is this curtain that the trapped air hits and bounces off creating the positive transient (see Figure 7).

Pressure transients are very simply the physical communication of a condition at one point in a system to another point. This means that if there is an event at point A then this information is communicated to point B some distance away by means of a pressure wave. The wave moves much faster than the air in which it travels and can move in any direction, not necessarily in the flow direction. In a pipe the speed at which an air pressure transient travels is the acoustic velocity, approximately 1,050 ft/sec.

Over the years the industry has relied on either designing dedicated passages (relief vents) for positive transients or complicated, limiting devices (aerator and de-aerator fittings) in order to prevent any discharge to ever reaching terminal velocity, no matter how tall the building is. As it was in the case of AAVs, STUDOR was first to research and bring to market a device which efficiently and cost-effectively removes the threat of positive transients.

The P.A.P.A. (Positive Air Pressure Attenuator) device acts like a water-hammer arrestor but for air. Unlike most water-hammer arrestors though, the P.A.P.A. device does not rely on compressed gas or springs for its operation. Naturally occurring conditions (positive pressure) are all that's needed to make the P.A.P.A. work. For these reasons, the P.A.P.A. is a non-maintenance item guaranteed to last as long as the DWV system in service.

How it works: When the flow from a discharge (and following vacuum) goes by the branch-off fitting, the bladder inside the P.A.P.A. is primed. After the air trapped by the flow, bounces off the water curtain and the positive transient is created, it begins its journey upward through the system. As the transient passes by the branch-off fitting some of it follows the alternative route and finds its way into the P.A.P.A. (see figure 7A). At that very moment the bladder begins to expand, a differential pressure is created at the branch-off point. This immediately makes the branch the path of least resistant (much like a short in an electrical loop) causing the vast majority of the transient to enter the P.A.P.A. The inflating bladder quickly (0.2 seconds) absorbs the energy of the transients thus reducing its speed to a harmless 40 ft per sec. The small volume of air is then released back into the system with no consequence.

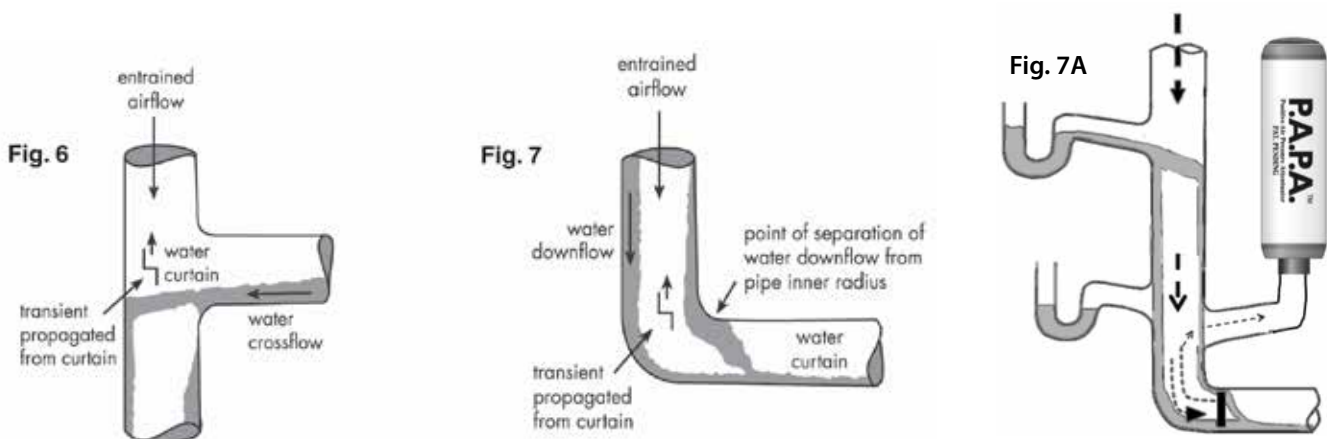

Installation of the P.A.P.A.™ Device

Installation: Single P.A.P.A. Device

Note: The P.A.P.A. device can be installed in the Vertical or Horizontal position.

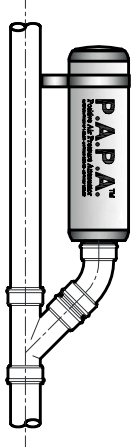

When mounting the P.A.P.A. device vertically the P.A.P.A. device should be independently supported by an anchor connected to its housing as shown in the left diagram. The anchor's metal hoop around the P.A.P.A. housing unit should allow for expansion and contraction and be rubber lined to prevent damage. Alternately, the P.A.P.A. should be connected to the pipe with the use of a no-hub coupling or flexible coupling.

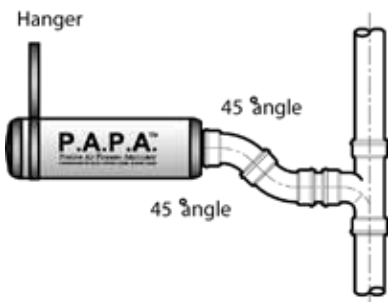
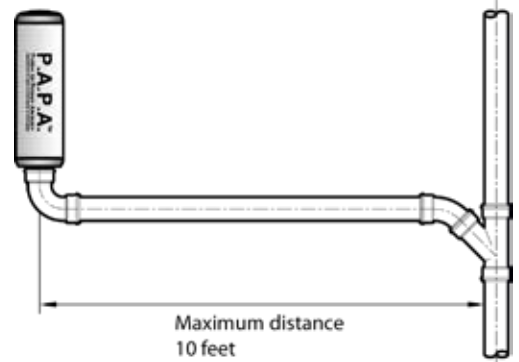

When mounting horizontally (it is advisable to maintain a minimum of a few degrees of slope so as to induce self draining), or at any angle up to 90 degrees, the P.A.P.A. device should be supported or anchored as shown in the left diagram. The portion of the support or anchor in contact with the device housing should allow for expansion and contraction and be rubber lined to prevent damage.

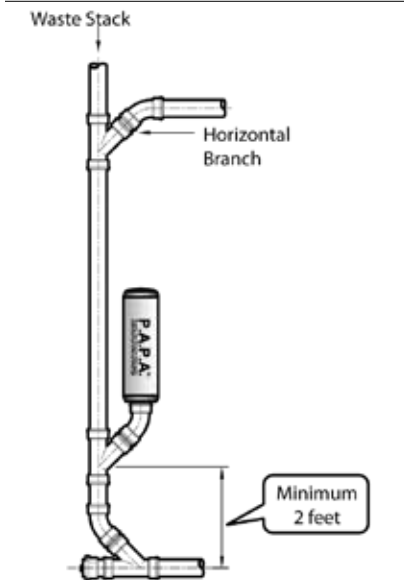
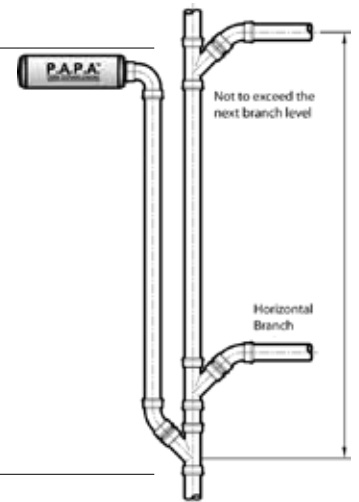

Stack extending no more than 5 floors above the base of the stack or offset should be a minimum of 2 feet

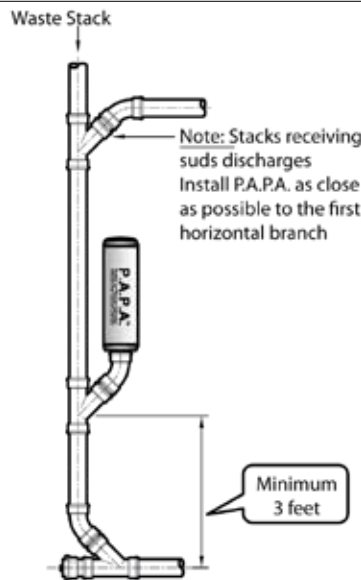

Stack extending more than 5 floors above the base of the stack or offset should be a minimum of 3 feet



Use a no-hub coupling or flexible coupling to connect the P.A.P.A. device to the system

Minimum distance shall be measured from center to center

Installation of the P.A.P.A.™ Device

Installation: Two or More P.A.P.A. Devices

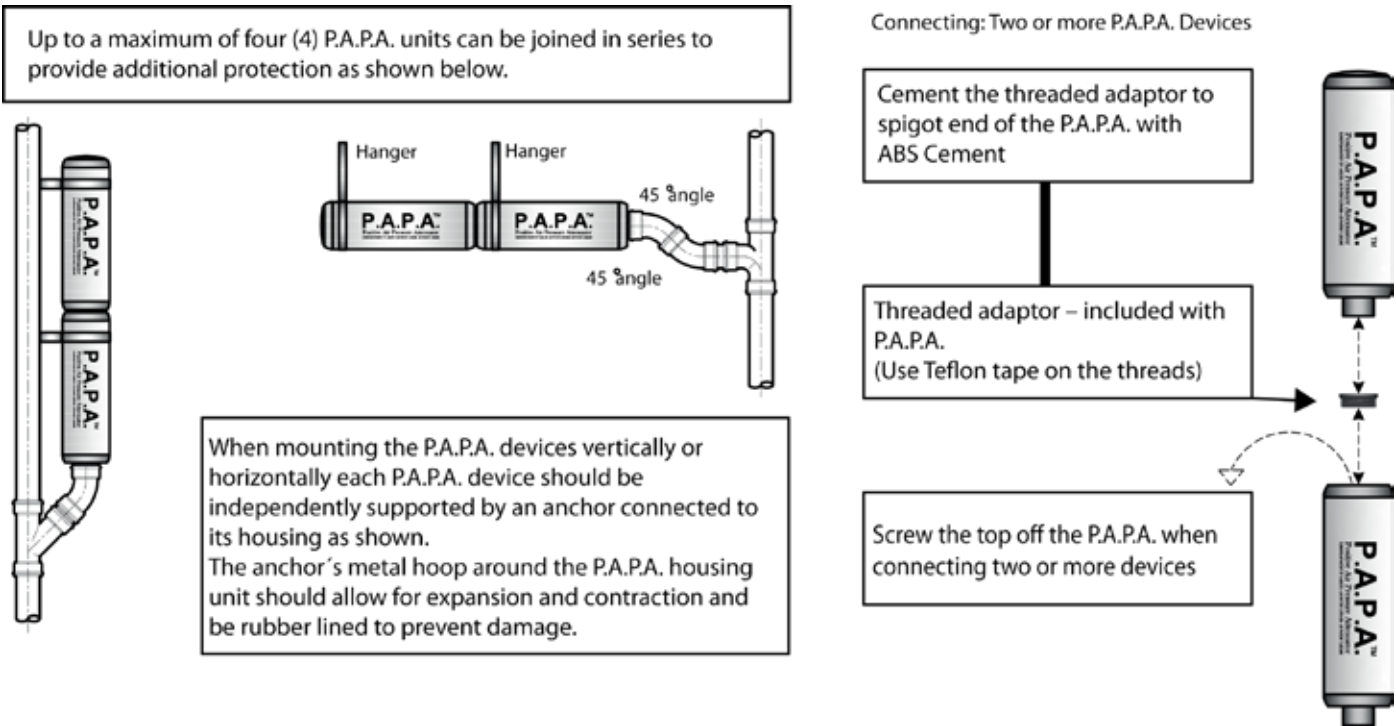

Note: The P.A.P.A. must be installed after the System's pressure test, in an accessible location.

Note: Accessible; in regard to the P.A.P.A. device is defined as noting the location of the P.A.P.A. device on the final plans for the building. The P.A.P.A. may be located behind the sheetrock wall or ceiling without an access panel. If the P.A.P.A. is located behind a concrete wall or block wall an access panel is required.

P.A.P.A.™ Design Criteria - “Studor Single Pipe System (SSPS)”

P.A.P.A. Design Criteria

There are several issues to be recognized as the drainage and vent system respond to positive transients propagation:

- The pressure profile is constantly changing.
- The area of risk to trap water seals is dynamic and constantly changing.
- The volume of extra air in the system will depend on airflow rate, closure times of blockage and the AAVs pipe period of the system; all of which are not constant.

To deal with these certainties, the P.A.P.A. device should be distributed throughout the system. The following is only a guide line of how many P.A.P.A. devices would be required per stack. This would vary depending on the plumbing design. **Please consult Studor, Inc. with any questions regarding the design of the system.**

Height of Stack Above Base or Offset Number of Floor Levels	Location of Additional P.A.P.A. Devices
4 - 10	1 P.A.P.A. at the Base
11 - 15	1 at Base, 1 at Mid-Level
16 - 25	1 at Base, 1 at 5th Floor and 1 at the Halfway Point of the Remaining Floors Above the 5th Floor
26 - 50	2 P.A.P.A. in Series at Base and at Intervals Not Exceeding 5 Floors Up to Level 25 and at an Interval Not Exceeding 10 Floor Above Level 25
51 or More	Studor Must Be Consulted

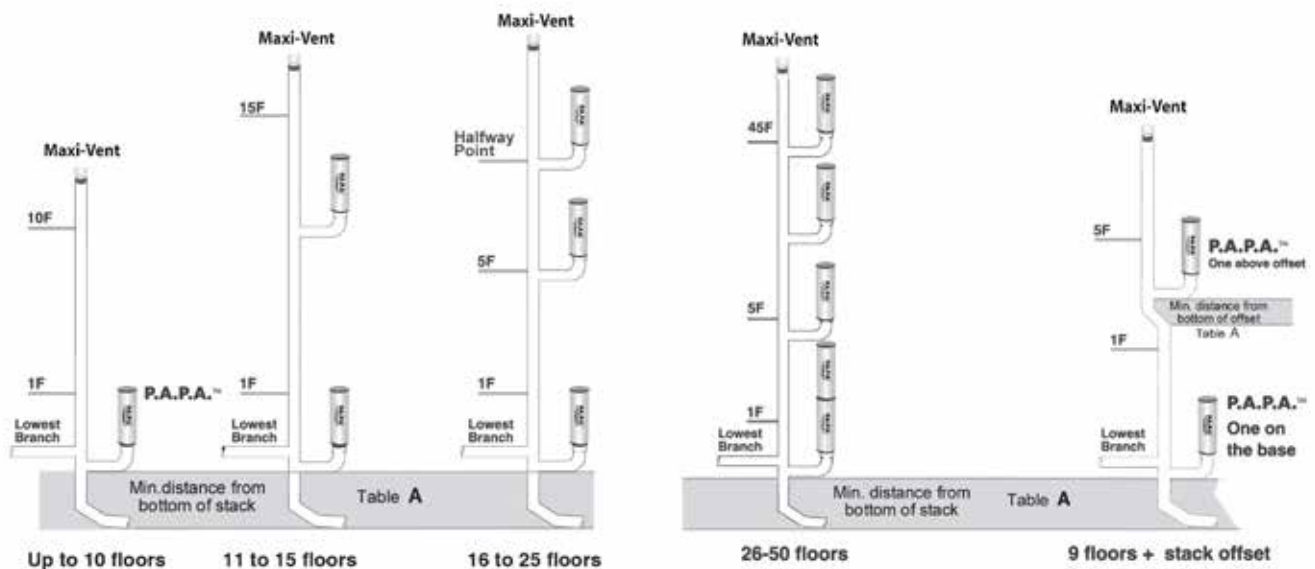

Table A. Minimum Distance

Stack Extending No More Than 5 Floors Above the Base of the Stack or Offset	2 Ft
Stack Extending More Than 5 Floors Above the Base of the Stack or Offset	3 Ft
Stack Receiving Suds Discharges	As Close As Possible to the First Horizontal Branch

Minimum Distance Shall Be Measured from Center to Center

P.A.P.A.™ Design Criteria - “Studor Single Pipe System (SSPS)”

With the **P.A.P.A.** devices installed throughout the system, the protection against positive transients would never be more than 10 floors away. Therefore the transient is dealt with before it can affect the whole system. It is essential to recognize that to be effective, a pressure transient attenuator must be placed between the source of the transient and the fixture to be protected.

The **P.A.P.A.** device is a maintenance free product and we recommend that it is accessible. Fluids and suds entering the device will not restrict the device’s ability to neutralize the negative effects of pressure transients nor will they compromise the life expectancy of the device.

Note: The **P.A.P.A.** does not solve the problem of a slow buildup of pressure, a sustained positive pressure originating from deposits blocking the pipes, the blockage of a public sewer, an over-loaded septic tank, etc. This is an inherent problem that must be resolved with or without the installation of **P.A.P.A.** devices or AAVs.

STUDOR offers a full planning service for designs of drainage venting systems incorporating the STUDOR products.

Studor has prepared this standard detail to demonstrate Studor’s recommended installation of its products. In the addition to Studor recommendations, there may be other national, state or local specifications that are pertinent to this application.

Studor Inc. standards do not supersede any national, state or local specification and Studor recommends that those requirements be reviewed and consulted with Studor prior to the installation of Studor products.

Studor has not authorized, and it bears no responsibility for any revisions, alternations or deviations from this. There must be a minimum of one vent to open atmosphere per building system.

The P.A.P.A. Device May Be Utilized in Conjunction with a Conventional System

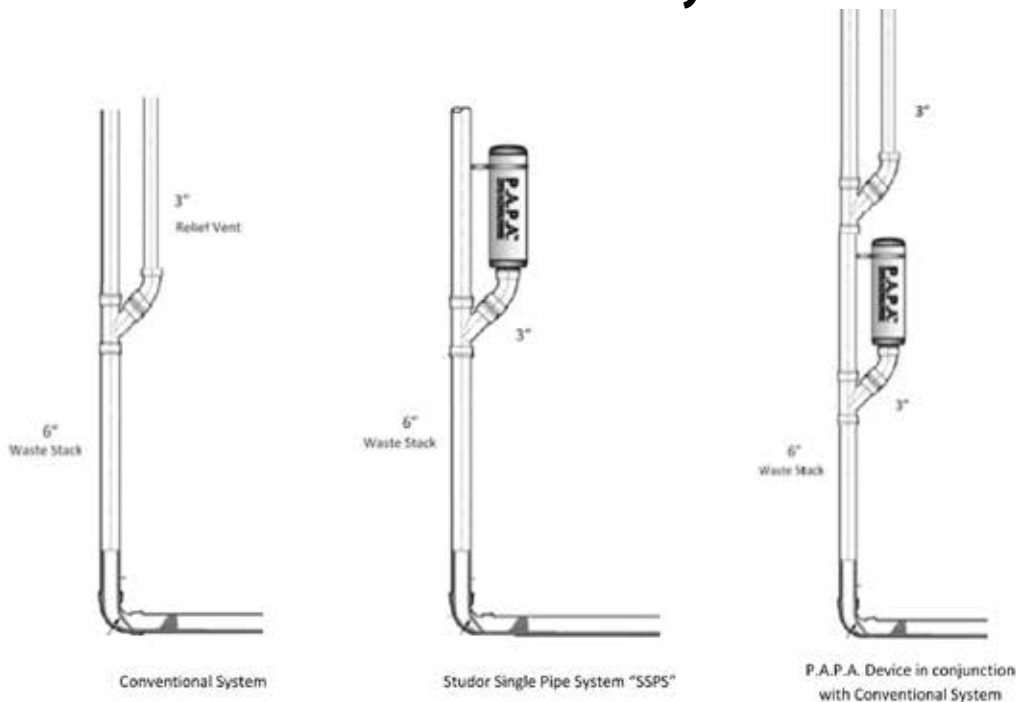

P.A.P.A.™ Design Criteria - “Studor Single Pipe System (SSPS)”

“No Connection Zone”

There shall be no connection between the P.A.P.A. device and the base of the stack, and no connection in the hydraulic zone as shown.

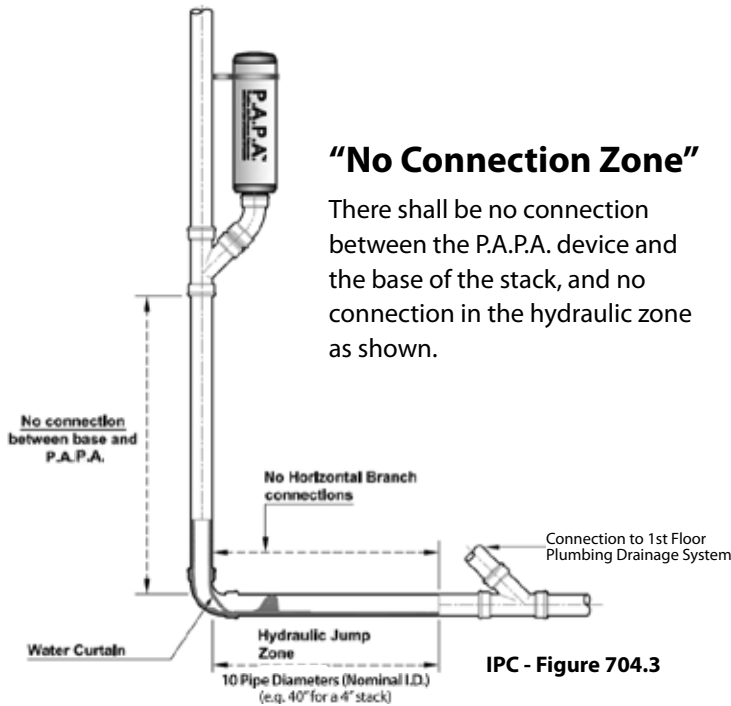

No connection between base and P.A.P.A. device

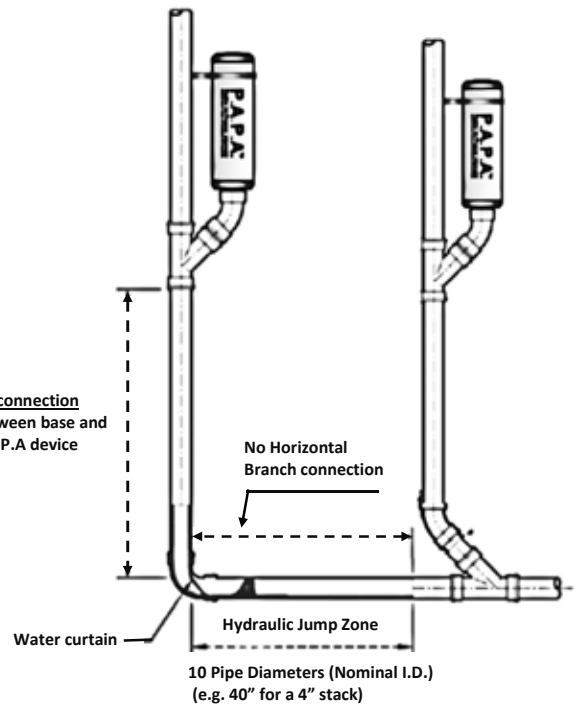

Typical Ground Floor Layout

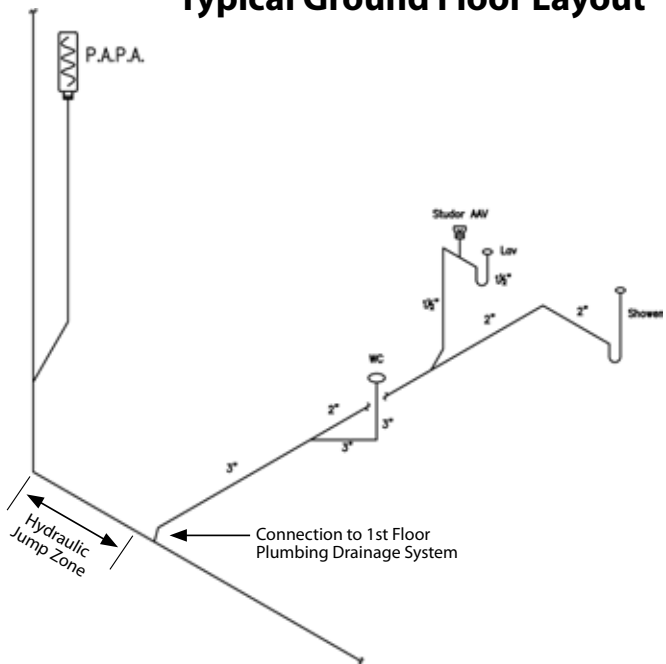

Hydraulic Jump Zone

“10 pipe diameters”
e.g. 30" for the 3" stack
e.g. 40" for a 4" stack

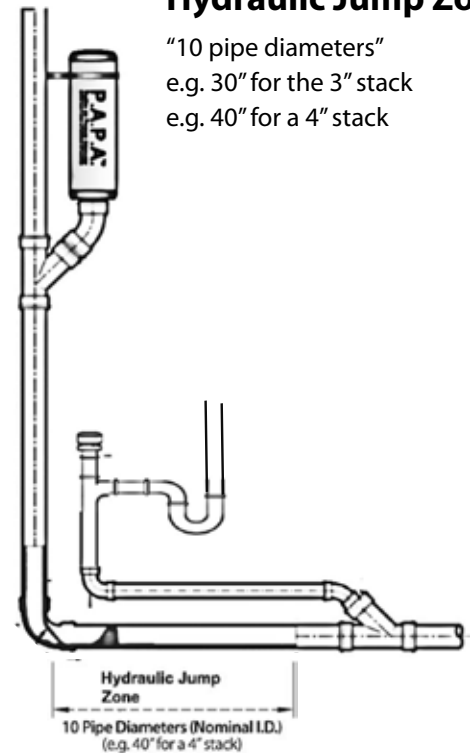

P.A.P.A.™ Design Criteria - "Studor Single Pipe System (SSPS)"

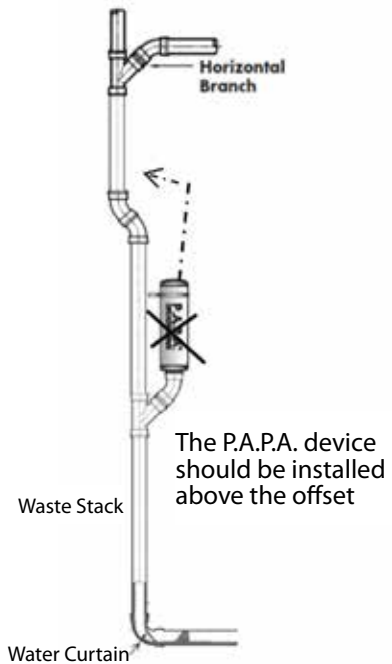
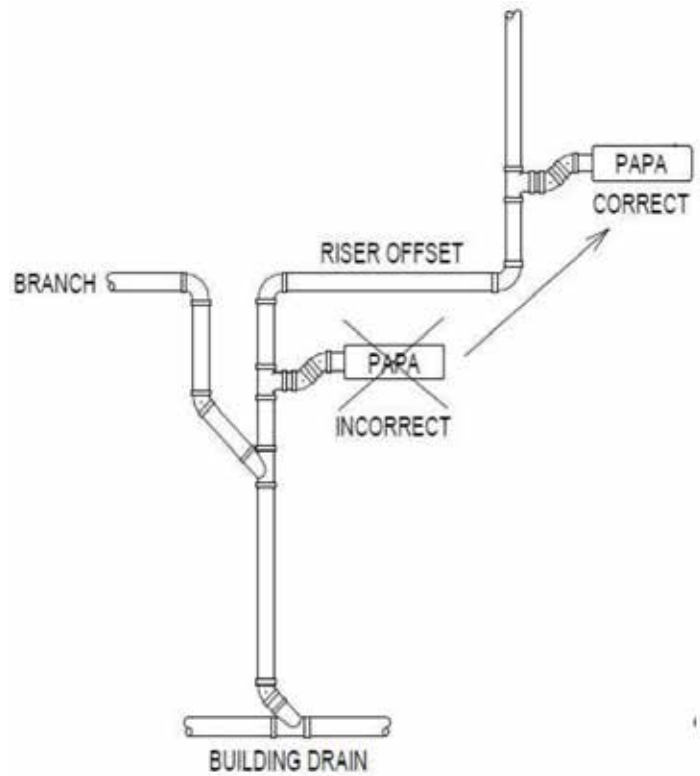
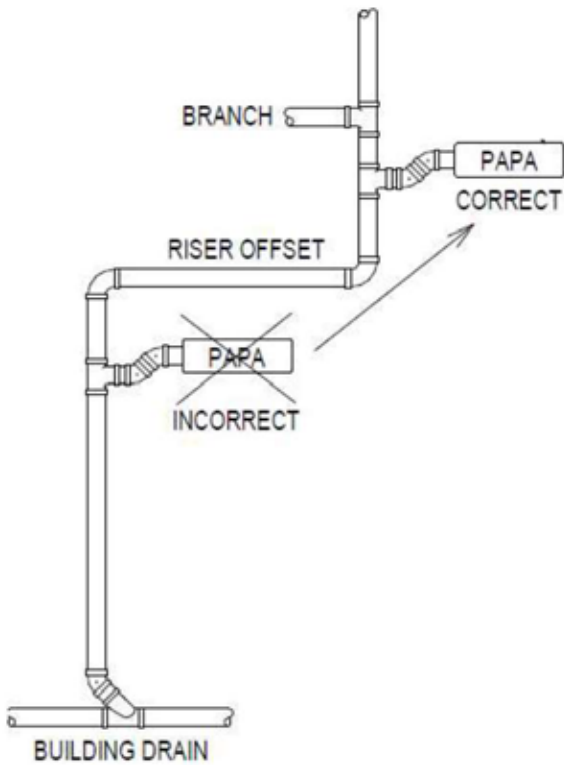

Incorrect Installation

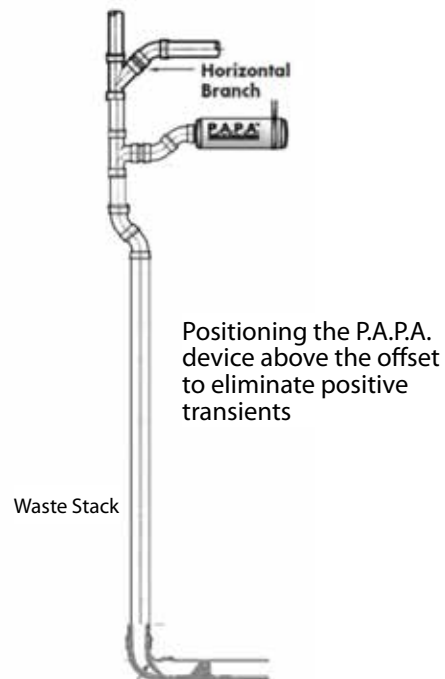

Positioning the P.A.P.A. device above the offset to eliminate positive transients

Correct Installation

P.A.P.A.™ Design Criteria - "Studor Single Pipe System (SSPS)"

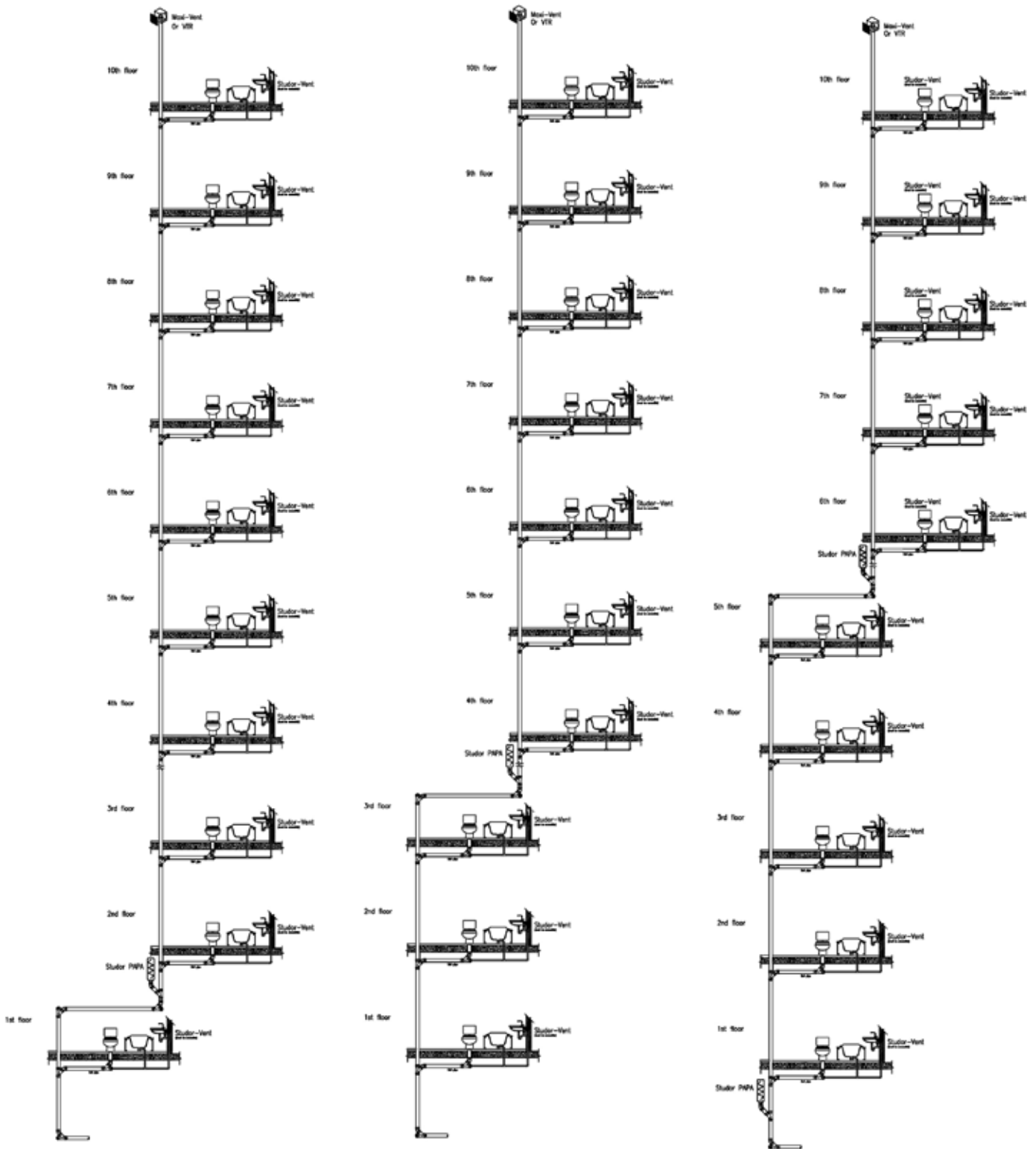

P.A.P.A.™ Design Criteria - "Studor Single Pipe System (SSPS)"

Typical Horizontal Wet Vented Bathroom Group

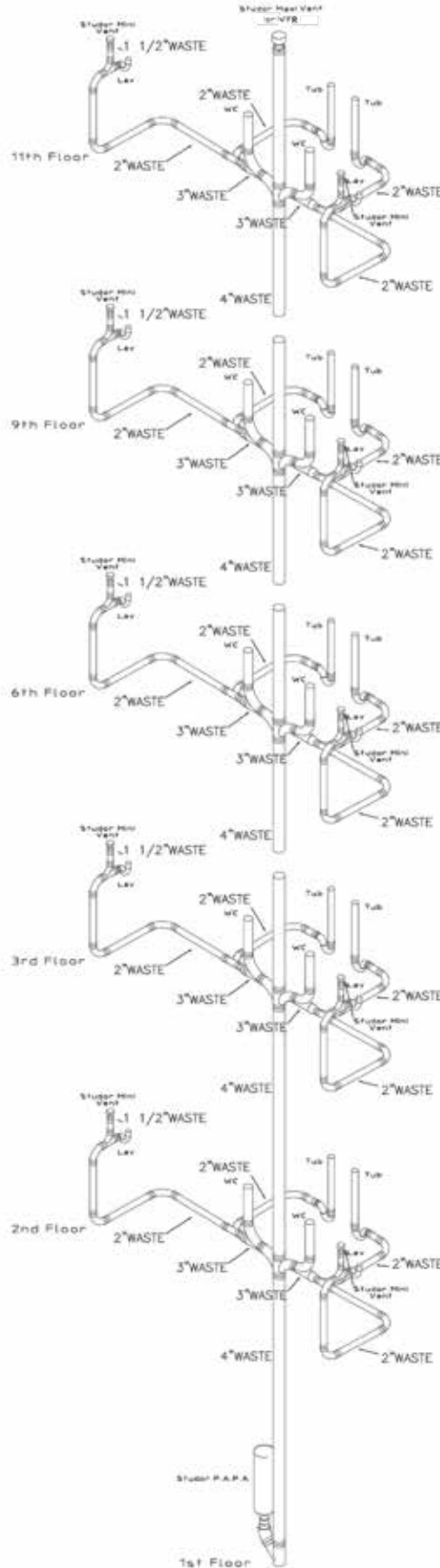

Note: Ensure that one open vent is maintained.

Studor Risers

STUDOR Risers with P.A.P.A. Devices and Studor Air Admittance Valves

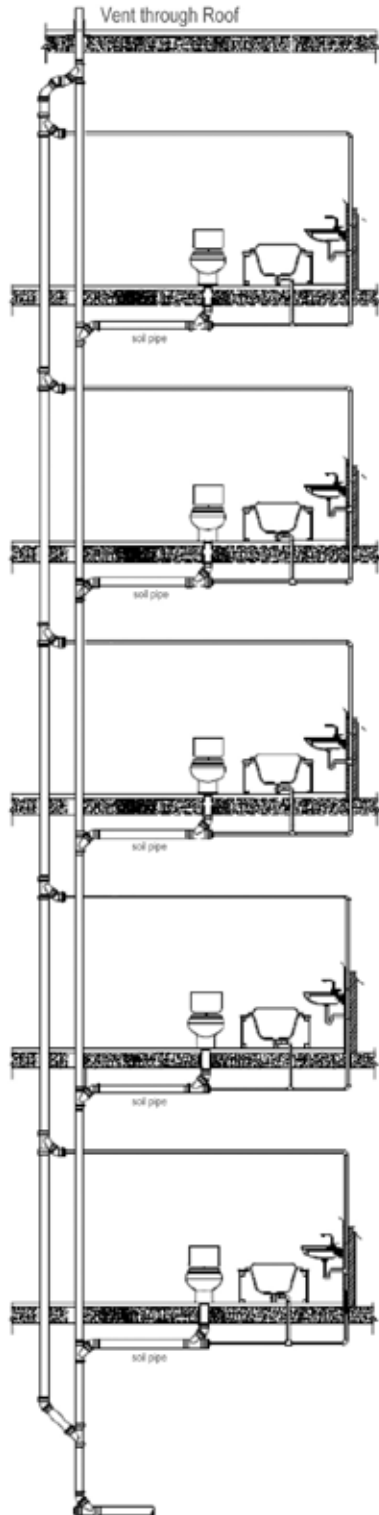

Conventional System

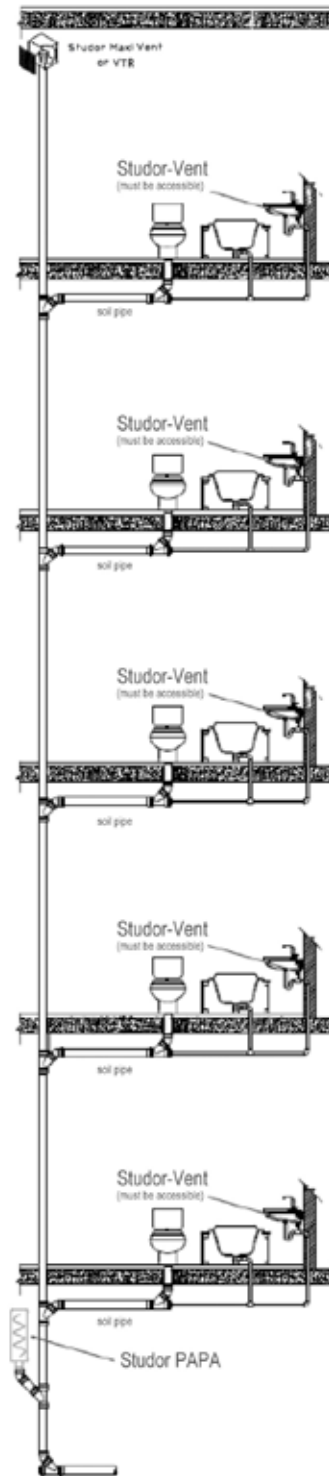

“Studor Single Pipe System (SSPS)”

Note: Ensure that one open vent is maintained.

Studor Risers

STUDOR Risers with P.A.P.A. Devices and Studor Air Admittance Valves

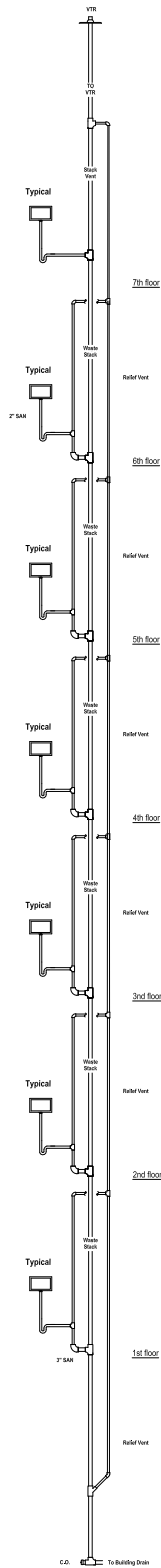

Conventional System

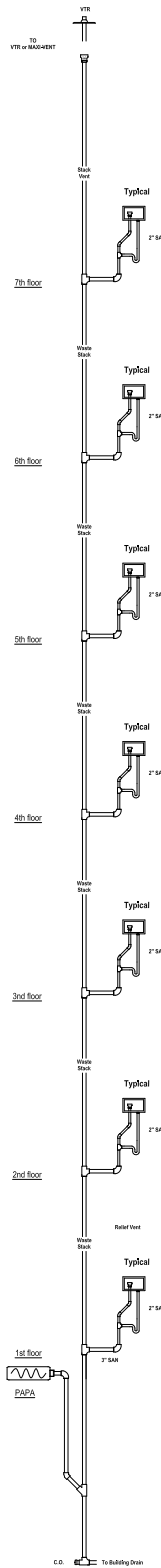

“Studor Single Pipe System (SSPS)”



**Water-Tite Du-All™
Washer Box with Redi-Vent**

Standards and Listings - P.A.P.A.

P.A.P.A. Standards are the industry's benchmark for any given product. A standard will identify the minimum performance criteria of a product. Being the proprietor of the P.A.P.A. exclusive technology STUDOR was also instrumental, working with ASSE, in the development of today's applicable standards.

All P.A.P.A. (Positive Air Pressure Attenuator) devices are tested and conform to the following standards:

- ASSE 1030-2013 (Positive Pressure Reduction Devices for Sanitary Drainage Systems)
- ASSE Seal of Approval
- ANSI Approved

The fundamental technical parameter of ASSE 1030 as related to the performance of the Positive Pressure Reduction Devices as follows:

It is important to note that all STUDOR P.A.P.A. devices not only meet all but exceed one or more of the above parameters.

Product listings are also a fundamental part of the product makeup. Without listing there would be no independent third party certification that a given product actually conforms to the relevant standard(s).

Temperature-40° F to +150° F (-40° C to +65.6° C)

Pressure.....5 PSI

Device Opening TimeWithin 10msec

Air Tightness Test - Positive Pressure Reduction Device

Controlled Temperature.....73.4°F ± 3.6°F (23.0°C ± 2.0°C).

Applied Air Pressure5 PSI

Ramp Time.....15 Seconds

Test Duration.....5 Minutes

Maximum Allowance Pressure Loss.....0.25 PSI

Capacity Rating Test - Positive Pressure Reduction Device

Controlled Temperature.....73.4°F ± 3.6°F (23.0°C ± 2.0°C).

Minimum Allowable Capacity4.23 US Quarts (4 liters)

All STUDOR P.A.P.A. (Positive Air Pressure Attenuator) devices are listed and certified by the following:



Note: The P.A.P.A. device has been tested and complies with ASSE 1030. After the P.A.P.A. device has been installed according to the manufacturer's instructions there is no further testing or maintenance required.

The Following is the NSF 14 Schedule for Testing of STUDOR P.A.P.A. Devices:

Test	Device
Air Tightness Test	Annually
Capacity Rating Test	Annually
Product Standards	Annually

Building Drainage Waste and Vent Systems: Active Pressure Control Devices

There are few real mysteries remaining about the mechanisms at play in building drainage and vent systems. This has been well understood from the beginning of modern sanitary engineering, which dates back to the end of the 19th Century. The description of building drainage and vent system operation is best understood in the context of engineering science in general and fluid mechanics.

At the center of the drainage system's integrity is the water trap seal, which stops sewer gas from entering a habitable space from the sewer. The water trap seal is usually 2 inches in depth depending on the fixture it is protecting.

It comes as a surprise to many that the flow of air is as important, if not more important, than the flow of water to the safe operation of the drainage system. This airflow is 'induced' or 'entrained' by the flow of water. The unsteady nature of the water flows causes pressure fluctuations (known as pressure transients) which can compromise water trap seals and provide a path for sewer gases to enter the habitable space.

Transients can be dealt with by a combination of careful design and the introduction of pressure control devices as close to the area of concern as possible. Long vent pipes can be an inefficient way of providing relief due to friction in the pipe. Distributing air supply inlets using air admittance valves (AAVs) around a building provides an efficient means of venting by allowing air to enter the system and they also reduce the risk of positive transient generation. AAVs do not cause positive pressure transients, they merely respond to them by closing, and hence reflect a reduced amplitude wave.

The introduction of a positive air pressure transient alleviation device known as the P.A.P.A. (Positive Air Pressure Attenuator) provides a means to 'blow off' pressure surges as close to their source, thereby protecting water traps. Attenuation of up to 90% of the incident wave can be achieved, thus protecting the entire system. It should be noted that there is little that can be done for a system experiencing a total blockage, generating excessive static positive pressures in the drainage system. In such circumstances the lowest water trap seal will 'blow' providing relief for the whole system. This will occur regardless of the method of venting employed.

In validated test simulations AAVs have been shown to provide at least as good protection for water trap seals as a system, completely vented with piping to the outdoors and in tall buildings in some circumstances, even better. The fully engineered designed active control system utilizing AAVs for negative pressure relief and P.A.P.A.s for positive transient relief is shown to be an effective method for balancing the need for safety and efficiency while maintaining functionality invisible to the user.

What are Pressure Transients?

A negative pressure transient communicates a need for more air and represents a suction force while a positive pressure transient communicates the need to reduce the air flowing and represents a pushing force. A negative transient can be caused by air leaving the system (hence the need for more air) and a positive transient can be caused by the air reaching a closed end (stopping the air where there is no escape route).

A negative transient will attempt to suck water out of a water trap seal. The pressure differential may not be sufficient to completely evacuate the water the first time, but the effect can be cumulative. Positive air pressure transients cause air to be forced through the water seal from the sewer side to the habitable space inside.

The need to communicate an increase or decrease in the air flow and the finite time that this takes is central to the requirements of providing a safely engineered drainage system. The absolute key to maintaining a state of equilibrium in a drainage system is to provide pressure relief as close to where it will occur as possible. If negative pressure transients are a call for more air then positive pressure transients are a call to stop sending air.

Modeling Flows in Drainage Networks

Research and analysis of real building drainage systems is complicated by the difficulty in obtaining data from 'live' buildings. Most areas of engineering employ some form of modeling technique in research and development in their 'look and see' approach to development. In DWV research there are few models capable of dealing with the complex time dependent transient flows. The computer model AIRNET, developed by Professor John Swaffield, Heriot-Watt University (Scotland), is such a model capable of such a complex task. At the heart of the AIRNET model is the mathematical technique known as the method of characteristics. The technique allows the propagation of waves to be predicted

Research

along the length of a pipe at different time steps. This is a very powerful and unique way to 'look and see' what is actually going on inside a building drainage system. The simulations in this study were carried out using AIRNET.

Two Story Building

A two story building drainage system can operate sufficiently well with minimal additional ventilation as long as it is designed and installed properly. This is borne out by reference to the installation shown in Figures 1 and 2. The building represents a fairly common house with a number of bathrooms and a group branch in a kitchen / laundry area. The simulation was run in two different scenarios.

1. System with an open pipe vent
2. System with AAVs

A discharge flow rate was simulated from the top floor consisting of a combined flow from a WC and a bath. This discharge was simulated from the upper floor and the effect on the water trap indicated by shading was recorded from the output data. It can be seen from the bar graph shown in Figure 3 that little water has been lost as a result of the operation of system devices in either scenario.

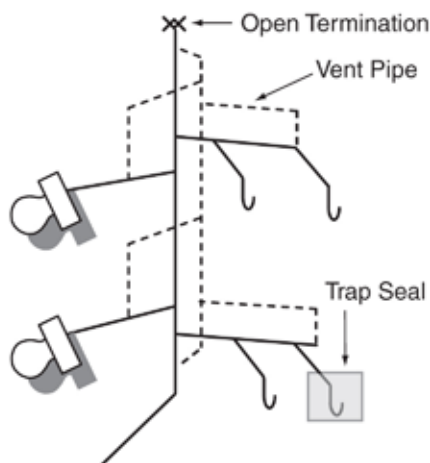

Figure 1. Fully vented system with open top and parallel vent pipe

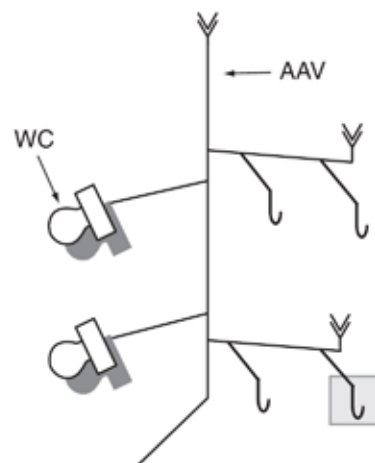

Figure 2. Two story house with AAVs on branches and an AAV termination at the top of the stack

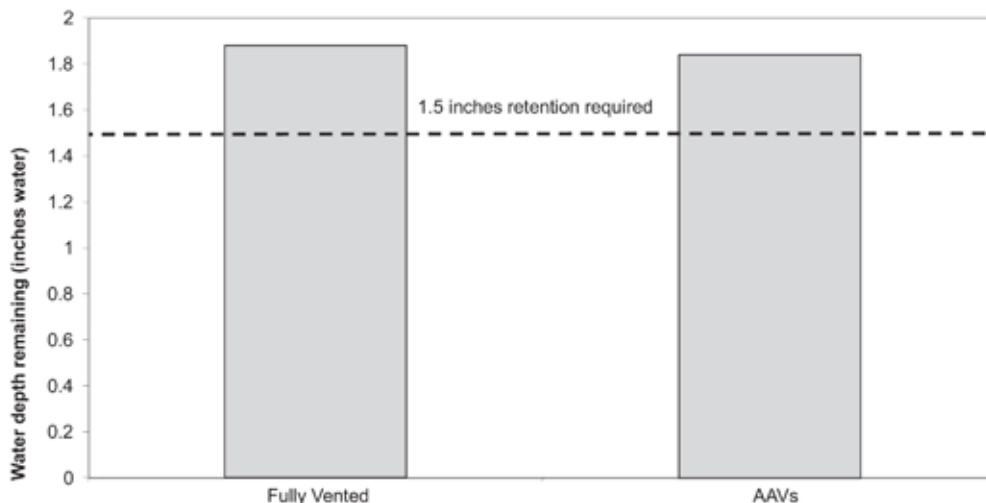
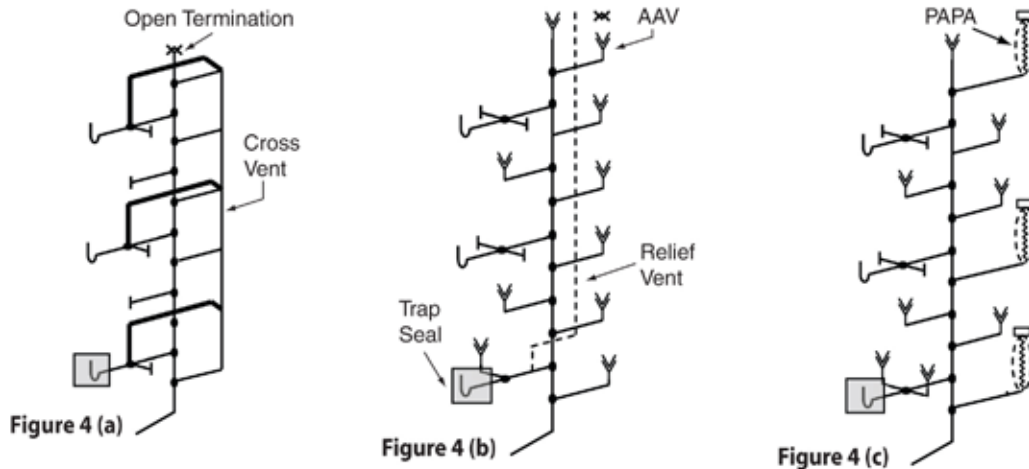

Figure 3. Comparison of water retained in the ground floor trap indicated (shaded on schematic)

Research

The 10 story building scenario is shown in Figure 4 below. There are basically three installation types being simulated here; the fully vented system Figure 4 (a) and a one pipe system with distributed venting and an AAV on the top of the stack, Figure 4 (b). This system also includes a relief vent. Figure 4 (c) is the one pipe system with distributed AAVs and P.A.P.A.s subjected to a positive air pressure transient simulated to replicate the occurrence of a surcharge in the sewer. In each of the scenarios a representative water trap is shown on three floors up the building.



The flow rate used in this simulation represents a maximum for the 4" vertical stack in question (80 gpm). This flow rate is unlikely to be observed in practice as the simultaneous discharges required are a probabilistic impossibility (Hunter 1940) The flow rate is therefore indicative of a 'worst case scenario' in order to push the drainage vent system to its limits, and therefore show comparisons between the options investigated. The discharges making up the flow rate are distributed evenly along the stack to simulate a number of simultaneous discharges (approximated 16 gpm from 5 different floors).

The bar graph shown in Figure 5 illustrates the water depth retained in the shaded water trap in Figure 4 following this event. It can be seen that under these conditions the system with AAVs installed (Figure 4b) has retained more water than the open pipe system (Figure 4a). Why is this? Well, the main reason is that the flow in the vertical stack induces a negative pressure transient as it calls for more air. This negative transient propagates to all parts of the system "looking for air". The negative transient represents a suction force which will try to draw water out of the trap seal. If the negative transient is too great it will suck water out of the trap. To stop this happening, air must be provided from somewhere else. The methods shown in Figure 4(a) and Figure 4(b) show two different methods. In figure 4(a) the air must travel from the top of the stack, approximately 100 feet away (but only after the negative transient has propagated to the top of the stack first so the round trip is approximately 200 feet).

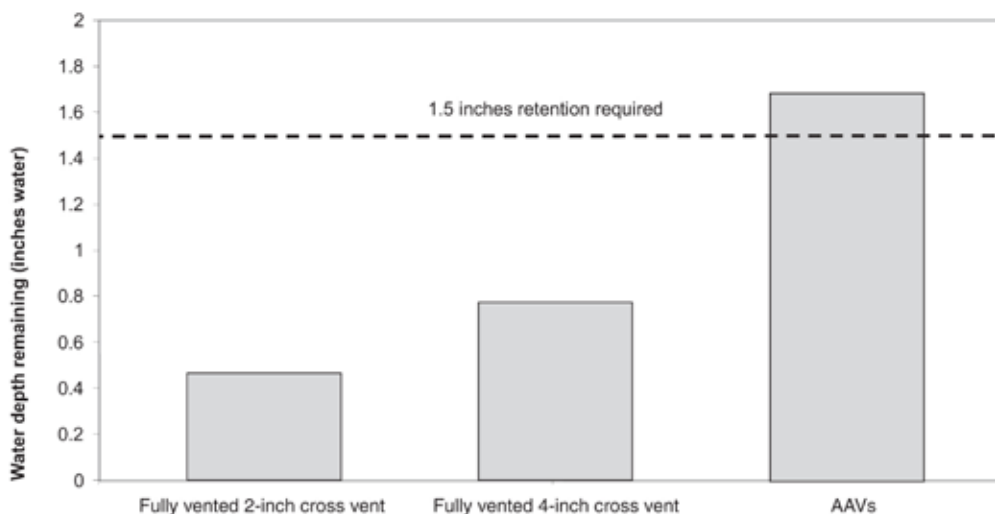

Figure 5. Comparison of water retained in the lowest water trap (shaded on schematic) conditions based on negative transient

Research

Alternatively, air can be provided locally by the provision of an AAV (Figure 4(b)). In this case the round trip is only a matter of 10 feet. This means that the air can be provided quicker than the fully vented system.

Figure 6 shows the trap retention on the same trap as the result of a positive pressure transient in the system. The positive transient was generated by simulating a surcharge in the sewer, causing the airflow through the stack to be stopped. Again two methods of dealing with this scenario; the fully vented system shown in Figure 4(a) and the active control option utilizing AAVs and P.A.P.A.'s as shown in Figure 4(c). The bar graph of trap retention clearly shows that the active control system protects against this sort of event, and that the AAV system with a relief vent shown in Figure 4(b) provides better protection than the fully vented system in Figure 4(a). The reasons for active control being better are two-fold; firstly, the distribution of the air inlets reduces the maximum positive pressure possible in the first place and secondly, the P.A.P.A. presents a volume which can consume the positive pressure wave, attenuate it and destroy it, rendering it harmless. This is borne out by the amount of water displaced by the positive pressure wave.

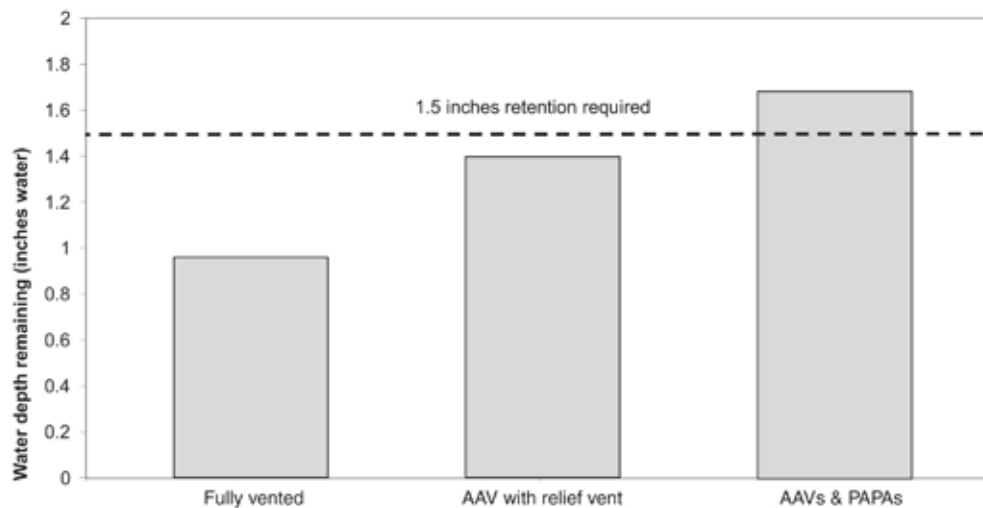

Figure 6. Comparison of water retained in the ground floor trap indicated (shaded on schematic) conditions based on positive transient

Conclusion

This article has considered the implications for venting in building drainage systems. It has concentrated on the fundamental fluid mechanics which so readily describe the unsteady flows resulting from plumbing fixture discharges. The description of the workings of a drainage and vent system in these terms is not new, since many early innovators were well aware of this. However many codes and regulations worldwide seem to avoid the engineering imperative of a description based on fluid mechanics in favor of a prescriptive legalistic approach based on the evolution of the industry rather than the science.

Air admittance valves (AAVs) have been installed worldwide since the early 1970s and in North America since 1989. Millions of valves have been installed; they have been field tested and are operating successfully. The Positive Air Pressure Attenuator (P.A.P.A.), which was invented by Professor John Swaffield and Dr. David Campbell of Heriot-Watt University, Scotland, was introduced in North America in 2004. Since their introduction, hundreds of projects (with AAVs and P.A.P.A.s installed) have been completed, with multiple projects under construction in which AAVs and P.A.P.A.s have been specified. Design professionals have realized that these "active pressure control devices" are a viable option to open pipe venting and solvent systems.

Note: This article is mainly comprised of excerpts from a recent study prepared by Professor John Swaffield and Dr. Michael Gormley of Heriot-Watt University in Scotland entitled Building Drainage Waste and Vent Systems: Options for Efficient Pressure Control. Copies of this study can be obtained at www.studor.com under the news section or by contacting Studor, Inc.

Materials Properties

Product: Maxi-Vent[®], Mini-Vent[®], Redi-Vent[®]

Material of Construction: Acrylonitrile Butadiene Styrene (ABS)

Mechanical			
Property	Typical Data	Unit	Method
Tensile Modulus c73 F, 2.0 in/mm	5,500	PSI	ASTM D 638
Elongation at Break @ 73 F	45	%	ASTM D 638
Modulus of Elasticity @ 73 F	240,000	PSI	ASTM D 790
Modulus of Elasticity @ 176 F	185,000	PSI	ASTM D 790
Compressive Strength	6,150	PSI	ASTM D 695
Flexural Strength	13,000	PSI	ASTM D 790

Impact			
Property	Typical Data	Unit	Method
Izod Impact, Notched	8.5	Ft-Lb/In	ASTM D 256

Physical			
Property	Typical Data	Unit	Method
Specific Gravity, Solid	1.04	--	ASTM D 792
Water Absorption 24 Hours	0.01	%	ASTM D 570

Thermal			
Property	Typical Data	Unit	Method
Coefficient of Linear Expansion	5.0 x 10 ⁻⁵	In/In/F	ASTM D 696
Heat Deflection - Temp. @ 66 PSI Load	200	F	ASTM D 648
Heat Deflection - Temp. @ 264 PSI Load	180	F	ASTM D 648
Thermal Conductivity	1.31 - 2.32	BTU/In/Ft ² F/Hr	ASTM C 177

Materials Properties

Product: Tec-Vent®

Material of Construction: Polycarbonate (Lexan)

Mechanical

Property	Typical Data	Unit	Method
Tensile Str, Yld, Type 1, 2.0 in/mm	8,500	PSI	ASTM D 638
Tensile Elong, Brk, Type 1, 2.0 in/mm	130.0	%	ASTM D 638
Tensile Modulus, 2.0 in/mm	305,000	PSI	ASTM D 638
Flex Stress, Yld, 0.05 in/mm, 2" Span	12,900	PSI	ASTM D 790
Flex Mod, 0.05 in/mm, 2" Span	300,000	PSI	ASTM D 790
Hardness, H358/30	90	MPa	ISO 2039/1

Impact

Property	Typical Data	Unit	Method
Izod Impact, Notched, 73 F	15.0	Ft-Lb/In	ASTM D 256
Izod Impact, Notched, 22 F	12.7	Ft-Lb/In	ASTM D 256

Physical

Property	Typical Data	Unit	Method
Specific Gravity, Solid	1.18	--	ASTM D 792
Melt Flow Rate, 300C/1.2 kgf (0)	10.0	g/10 mm	ASTM D 1238
Density	1.19	g/cm ³	ISO 118

Thermal

Property	Typical Data	Unit	Method
Vicat Softening Temp, Rate B	299 Deg	F	ASTM D 1525
Relative Temp Index, Elec	125 Deg	C	UL 746B
Relative Temp Index, Mech w/Impact	115 Deg	C	UL 746B
Relative Temp Index, Mech w/o Impact	120 Deg	C	UL 746B

Electrical

Property	Typical Data	Unit	Method
Dielectric Constant, 1 MHz	2.90	--	ASTM D 150
Dissipation Factor, 1 MHz	0.0085	--	ASTM D 150

Flame Characteristics

Property	Typical Data	Unit	Method
UL File Number, USA	E121562	--	--
V0 Rated (Tested Thickness)	0.059	Inch	UL 94
5VA Rating (Tested Thickness)	0.118	Inch	UL 94
Oxygen Index (LOI)	35	%	ISO 4589

Materials Properties

Product: Chem-Vent®

Material of Construction: Flame-Retardant Polypropylene
Seal: Silicone seal on glass filled nylon stem

Mechanical			
Property	Typical Data	Unit	Method
Tensile Modulus, 2.0 in/mm	4,400	PSI	ASTM D 638
Flexural Modulus	215,000	PSI	ASTM D 790
Hardness, Rockwell R	100	--	ASTM D 1706

Impact			
Property	Typical Data	Unit	Method
Izod Impact, Notched	1.0	Ft-Lb/In	ASTM D 256

Physical			
Property	Typical Data	Unit	Method
Specific Gravity, Solid	0.94	--	ASTM D 1505
Water Absorption 24 Hours	0.01	%	ASTM D 570

Thermal			
Property	Typical Data	Unit	Method
Coefficient of Linear Expansion	6 x 10 ⁻⁵	In/In/F	ASTM D 696
Heat Deflection - Temp. @ 66 PSI Load	220 - 240	F	ASTM D 648
Heat Deflection - Temp. @ 264 PSI Load	195	F	ASTM D 648

Flame Characteristics			
Property	Typical Data	Unit	Method
Time of Burning	< 5	Sec	ASTM D 635
Extent of Burning	< 5	mm	--
Burning Class	V2	--	UL 94
Maximum Smoke Density	62.0	--	ASTM D 2843
Smoke Density Rating	40.1	--	--
Oxygen Index	28	%	ASTM D 2863

Materials Properties

Product: P.A.P.A.™

Material of Construction: ABS Component Acrylonitrile Butadiene Styrene

Mechanical

Property	Typical Data	Unit	Method
Tensile Modulus, 2.0 in/mm	5,370	psi	ISO 527
Flexural Modulus	305	ksi	2mm/min; ISO 178
Hardness, Rockwell R	110	R Scale	ASTM D785

Impact

Property	Typical Data	Unit	Method
Izod Impact, Notched	4.98	ft-lb/in 2 @ Thickness 0.125 in	ASTM D 256

Physical

Property	Typical Data	Unit	Method
Specific Gravity, Solid	1.03	g/cc	ISO 1183

Thermal

Property	Typical Data	Unit	Method
Heat Deflection	207	F	ASTM D648

Flame Characteristics

Property	Typical Data	Unit	Method
Flammability, UL94	HB	@ Thickness 0.0625 in	UL94

Product Specifications

The following specification text has been prepared following the CSI-3 Part Specifications format. Its purpose, to assist design professionals in the preparation of a specification incorporating Redi-Vent, Mini-Vent, Maxi-Vent, Tec-Vent, Trap-Vent, Chem-Vent air admittance valves, P.A.P.A. positive air pressure attenuator or Maxi-Filtra by Studor, Inc. Utilize these paragraphs to insert text into Specification Section 15150 – Sanitary Waste and Vent Piping, or similarly titled section governing this work.

Editing notes to assist in the proper editing of the specifications are included as grey text. Delete these notes from the final specification.

Websites listed in the editing notes are hypertext links: While connected to the internet, simply click on the underline text to go to the applicable web page.

For assistance on the use of the products in this section, **contact Studor, Inc.**

Redi-Vent®

PART 1 - GENERAL

Insert the following under "References." Edit to include only those standards used elsewhere in the specification.

1.X REFERENCES

- A. American Society of Sanitary Engineering (ASSE):
 - 1. Standard 1050 - Performance Requirements for Stack Air Admittance Valves for Sanitary Drainage Systems.
 - 2. Standard 1051 - Performance Requirements for Individual and Branch Type Air Admittance Valves for Sanitary Drainage Systems.
- B. International Association of Plumbing and Mechanical Officials (IAPMO) - Uniform Plumbing Code (UPC).
- C. International Code Council (ICC) - International Plumbing Code (IPC).
- D. International Code Council (ICC) - International Residential Code (IRC).
- E. NSF International/American National Standards Institute (NSF/ANSI) Standard 14 - Plastics Piping Systems Components and Related Materials.

If shop drawings, product data, or samples are desired, insert the following under "Submittals." Edit to include only those submittals actually required.

1.X SUBMITTALS

- A. Shop Drawings: Indicate valve locations, valve sizes, drain fixture units per branch size, and required clear dimensions in spaces to receive valves.
- B. Product Data: Include product description, drain fixture unit chart, and installation instructions.
- C. Samples: Full size sample of air admittance valve.

Insert the following under "Quality Assurance."

1.X QUALITY ASSURANCE

- A. Air Admittance Valves:

Edit the following to indicate applicable building or plumbing code.

- 1. Approved for use under [IPC, Section 918.] [IRC, Section P3114.] [UPC, Section 301.2 - Alternate Materials and Methods.]
- 2. Certified by NSF to NSF/ANSI Standard 14; bear NSF certification marking.
- 3. Certified to ASSE Standards 1051 and 1050; bear ASSE Seal of Approval.
- 4. ICC-ES PMG listed.
- 5. Bear Warnock Hersey (Intertek Testing Services, Inc.) Certification Mark.

Insert the following under "Warranties."

1.X WARRANTIES

- A. Provide manufacturer's limited lifetime warranty providing coverage for replacement of defective air admittance valves.

PART 2 - PRODUCTS

Insert the following under "Materials."

2.X MATERIALS

- A. Air Admittance Valves:
 - 1. Source: REDI-VENT by Studor, Inc.
 - 2. Components:
 - a. ABS valve body with Silicone membrane.
 - b. ABS or PVC female adapter (specifier to select one).
 - 3. Features:
 - a. Screening inside and outside of valve to protect sealing membrane from insects and debris.
 - b. Compact design.
 - c. Operating temperature: Minus 40 to plus 150 degrees F.

Edit the following to suit project requirements.

- 4. Connection size: [1-1/2 inches.] [2 inches.] [As indicated on Drawings.]

PART 3 - EXECUTION

Insert the following under "Installation."

3.X INSTALLATION OF AIR ADMITTANCE VALVES

- A. Install valves after drainage and waste system has been roughed in and tested.
- B. Locate valves minimum 4 inches above horizontal branch drain or fixture drain being vented.
- C. Install valves in accessible locations.
- D. Connect valves to piping in accordance with manufacturer's instructions.
- E. Install valves in upright position, within 15 degrees of true vertical.
- F. Extend minimum of one vent to open atmosphere for each building drainage system.
- G. In attics, install valves minimum 6 inches above attic insulation.
- H. Do not install valves on chemical waste systems or in supply and return air plenums.

Product Specifications

Mini-Vent®

PART 1 - GENERAL

Insert the following under "References." Edit to include only those standards used elsewhere in the specification.

1.X REFERENCES

- A. American Society of Sanitary Engineering (ASSE):
 - 1. Standard 1050 - Performance Requirements for Stack Air Admittance Valves for Sanitary Drainage Systems.
 - 2. Standard 1051 - Performance Requirements for Individual and Branch Type Air Admittance Valves for Sanitary Drainage Systems.
- B. International Association of Plumbing and Mechanical Officials (IAPMO) - Uniform Plumbing Code (UPC).
- C. International Code Council (ICC) - International Plumbing Code (IPC).
- D. International Code Council (ICC) - International Residential Code (IRC).
- E. NSF International/American National Standards Institute (NSF/ANSI) Standard 14 - Plastics Piping Systems Components and Related Materials.

If shop drawings, product data, or samples are desired, insert the following under "Submittals." Edit to include only those submittals actually required.

1.X SUBMITTALS

- A. Shop Drawings: Indicate valve locations, valve sizes, drain fixture units per branch size, and required clear dimensions in spaces to receive valves.
- B. Product Data: Include product description, drain fixture unit chart, and installation instructions.
- C. Samples: Full size sample of air admittance valve.

Insert the following under "Quality Assurance."

1.X QUALITY ASSURANCE

- A. Air Admittance Valves:

Edit the following to indicate applicable building or plumbing code.

- 1. Approved for use under [IPC, Section 918.] [IRC, Section P3114.] [UPC, Section 301.2 - Alternate Materials and Methods.]
- 2. Certified by NSF to NSF/ANSI Standard 14; bear NSF certification marking.
- 3. Certified to ASSE Standards 1050 and 1051; bear ASSE Seal of Approval.
- 4. ICC-ES PMG listed.
- 5. Bear Warnock Hersey (Intertek Testing Services, Inc.) Certification Mark.

Insert the following under "Warranties."

1.X WARRANTIES

- A. Provide manufacturer's limited lifetime warranty providing coverage for replacement of defective air admittance valves.

PART 2 - PRODUCTS

Insert the following under "Materials."

2.X MATERIALS

- A. Air Admittance Valves:
 - 1. Source: MINI-VENT by Studor, Inc.
 - 2. Components:
 - a. ABS valve with Silicone membrane.
 - b. ABS or PVC female adapter (specifier to select one).
 - c. ABS protection cover.
 - 3. Features:
 - a. Screening inside and outside of valve to protect sealing membrane from insects and debris.
 - b. Static seal design.
 - c. Protective cover against extreme temperatures, dirt and UV exposure.
 - d. Channels to divert condensation away from sealing membrane.
 - e. Operating temperature: Minus 40 to plus 150 degrees F, without protective cover.

Edit the following to suit project requirements.

- 4. Connection size: [1 1/2 inches.] [2 inches.] [As indicated on Drawings.]

PART 3 - EXECUTION

Insert the following under "Installation."

3.X INSTALLATION OF AIR ADMITTANCE VALVES

- A. Install valves after drainage and waste system has been roughed in and tested.
- B. Locate valves minimum 4 inches above horizontal branch drain or fixture drain being vented and minimum 6 inches above flood level of highest fixture being vented for stack applications.
- C. Install valves in accessible locations.
- D. Connect valves to piping in accordance with manufacturer's instructions.
- E. Install valves in upright position, within 15 degrees of true vertical.
- F. Extend minimum of one vent to open atmosphere for each building drainage system.
- G. In attics, install valves minimum 6 inches above attic insulation.
- H. Do not install valves on chemical waste systems or in supply and return air plenums.

Product Specifications

Maxi-Vent®

PART 1 - GENERAL

Insert the following under "References." Edit to include only those standards used elsewhere in the specification.

1.X REFERENCES

- A. American Society of Sanitary Engineering (ASSE):
 - 1. Standard 1050 - Performance Requirements for Stack Air Admittance Valves for Sanitary Drainage Systems.
 - 2. Standard 1051 - Performance Requirements for Individual and Branch Type Air Admittance Valves for Sanitary Drainage Systems.
- B. International Association of Plumbing and Mechanical Officials (IAPMO) - Uniform Plumbing Code (UPC).
- C. International Code Council (ICC) - International Plumbing Code (IPC).
- D. International Code Council (ICC) - International Residential Code (IRC).
- E. NSF International/American National Standards Institute (NSF/ANSI) Standard 14 - Plastics Piping Systems Components and Related Materials.

If shop drawings, product data, or samples are desired, insert the following under "Submittals." Edit to include only those submittals actually required.

1.X SUBMITTALS

- A. Shop Drawings: Indicate valve locations, valve sizes, drain fixture units per branch size, and required clear dimensions in spaces to receive valves.
- B. Product Data: Include product description, drain fixture unit chart, and installation instructions.
- C. Samples: Full size sample of air admittance valve.

Insert the following under "Quality Assurance."

1.X QUALITY ASSURANCE

- A. Air Admittance Valves:

Edit the following to indicate applicable building or plumbing code.

- 1. Approved for use under [IPC, Section 918.] [IRC, Section P3114.] [UPC, Section 301.2 - Alternate Materials and Methods.]
- 2. Certified by NSF to NSF/ANSI Standard 14; bear NSF certification marking.
- 3. Certified to ASSE Standards 1050 and 1051; bear ASSE Seal of Approval.
- 4. ICC-ES PMG listed.
- 5. Bear Warnock Hersey (Intertek Testing Services, Inc.) Certification Mark.

Insert the following under "Warranties."

1.X WARRANTIES

- A. Provide manufacturer's limited lifetime warranty providing coverage for replacement of defective air admittance valves.

PART 2 - PRODUCTS

Insert the following under "Materials."

2.X MATERIALS

- A. Air Admittance Valves:
 - 1. Source: MAXI-VENT by Studor, Inc.
 - 2. Components:
 - a. ABS valve with Silicone membrane.
 - b. Styrofoam protective cover.
 - c. Rubber connector.
 - 3. Features:
 - a. Screening inside and outside of valve to protect sealing membrane from insects and debris.
 - b. Protective cover and insulation against extreme temperatures.
 - c. Channels to divert condensation away from sealing membrane.
 - d. Operating temperature: Minus 40 to plus 150 degrees F, without protective cover.

Edit the following to suit project requirements.

- 4. Connection size: [3 inches.] [4 inches.] [As indicated on Drawings.]

PART 3 - EXECUTION

Insert the following under "Installation."

3.X INSTALLATION OF AIR ADMITTANCE VALVES

- A. Install valves after drainage and waste system has been roughed in and tested.
- B. Locate valves minimum 4 inches above horizontal branch drain or fixture drain being vented and minimum 6 inches above flood level of highest fixture being vented for stack applications.
- C. Install valves in accessible locations.
- D. Connect valves to piping in accordance with manufacturer's instructions.
- E. Install valves in upright position, within 15 degrees of true vertical.
- F. Extend minimum of one vent to open atmosphere for each building drainage system.
- G. In attics, install valves minimum 6 inches above attic insulation.
- H. Do not install valves on chemical waste systems or in supply and return air plenums.

Product Specifications

Tec-Vent®

PART 1 - GENERAL

Insert the following under "References." Edit to include only those standards used elsewhere in the specification.

1.X REFERENCES

- A. American Society of Sanitary Engineering (ASSE):
 - 1. Standard 1050 - Performance Requirements for Stack Air Admittance Valves for Sanitary Drainage Systems.
 - 2. Standard 1051 - Performance Requirements for Individual and Branch Type Air Admittance Valves for Sanitary Drainage Systems.
- B. International Association of Plumbing and Mechanical Officials (IAPMO) - Uniform Plumbing Code (UPC).
- C. International Code Council (ICC) - International Plumbing Code (IPC).
- D. International Code Council (ICC) - International Residential Code (IRC).
- E. NSF International/American National Standards Institute (NSF/ANSI) Standard 14 - Plastics Piping Systems Components and Related Materials.
- F. Underwriters Laboratories (UL) 2043 - Fire Test for Heat and Visible Smoke Release for Discrete Products and Their Accessories Installed in Air-Handling Spaces.

If shop drawings, product data, or samples are desired, insert the following under "Submittals." Edit to include only those submittals actually required.

1.X SUBMITTALS

- A. Shop Drawings: Indicate valve locations, valve sizes, drain fixture units per branch size, and required clear dimensions in spaces to receive valves.
- B. Product Data: Include product description, drain fixture unit chart, and installation instructions.
- C. Samples: Full size sample of air admittance valve.

Insert the following under "Quality Assurance."

1.X QUALITY ASSURANCE

- A. Air Admittance Valves:

Edit the following to indicate applicable building or plumbing code.

- 1. Approved for use under [IPC, Section 918.] [IRC, Section P3114.] [UPC, Section 301.2 - Alternate Materials and Methods.]
- 2. Certified by NSF to NSF/ANSI Standard 14; bear NSF certification marking.
- 3. Certified to ASSE Standards 1050 and 1051; bear ASSE Seal of Approval.
- 4. Certified by Underwriters Laboratories to UL 2043; bear UL Classification Mark.
- 5. ICC-ES PMG listed.

Insert the following under "Warranties."

1.X WARRANTIES

- A. Provide manufacturer's limited lifetime warranty providing coverage for replacement of defective air admittance valves.

PART 2 - PRODUCTS

Insert the following under "Materials."

2.X MATERIALS

- A. Air Admittance Valves:
 - 1. Source: TEC-VENT by Studor, Inc.
 - 2. Components:
 - a. Flame retardant polycarbonate valve with silicone membrane.
 - b. Channels to divert condensation away from sealing membrane.
 - c. Rated for exposure to ultraviolet.
 - 3. Features:
 - a. Screening inside and outside of valve to protect sealing membrane from insects and debris.
 - b. Operating temperature: Minus 40 to plus 150 degrees F.
 - c. Suitable for use on sewer ejectors and in supply and return air plenums if approved by local administrative authorities.
 - 4. Connection size: 1-1/2 NPT.

3.X INSTALLATION OF AIR ADMITTANCE VALVES

- A. Install valves after drainage and waste system has been roughed in and tested.
- B. Locate valves minimum 4 inches above horizontal branch drain or fixture drain being vented and minimum 6 inches above flood level of highest fixture being vented for stack applications.
- C. Install valves in accessible locations.
- D. Connect valves to piping in accordance with manufacturer's instructions.
- E. Install valves in upright position, within 15 degrees of true vertical.
- F. Extend minimum of one vent to open atmosphere for each building drainage system.
- G. In attics, install valves minimum 6 inches above attic insulation.
- H. Do not install valves on chemical waste systems.

Product Specifications

Chem-Vent®

PART 1 - GENERAL

Insert the following under "References." Edit to include only those standards used elsewhere in the specification.

1.X REFERENCES

- A. American Society of Sanitary Engineering (ASSE) Standard 1049 - Performance Requirements for Individual and Branch Type Air Admittance Valves for Chemical Drainage Systems.
- B. International Association of Plumbing and Mechanical Officials (IAPMO) - Uniform Plumbing Code.
- C. International Code Council (ICC) - International Plumbing Code (IPC).
- D. NSF International/American National Standards Institute (NSF/ANSI) Standard 14 - Plastics Piping Systems Components and Related Materials.

If shop drawings, product data, or samples are desired, insert the following under "Submittals." Edit to include only those submittals actually required.

1.X SUBMITTALS

- A. Shop Drawings: Indicate valve locations, valve sizes, drain fixture units per branch size, and required clear dimensions in spaces to receive valves.
- B. Product Data: Include product description, drain fixture unit chart, and installation instructions.
- C. Samples: Full size sample of air admittance valve.

Insert the following under "Quality Assurance."

1.X QUALITY ASSURANCE

- A. Air Admittance Valves:
 1. Certified by NSF to NSF/ANSI Standard 14; bear NSF/ANSI certification marking.
 2. Approved for use under [IPC, Section 918.]
 3. Approved for use in specialized chemical waste systems as an Engineered Product or part of an Engineered System under IPC, Section 301.2 - Alternate Materials and Methods, or IPC, Section 300.
 4. ASSE 1049 Performance requirements for Individual and Branch Type Air Admittance Valves for Chemical Drainage Systems.

Insert the following under "Warranties."

1.X WARRANTIES

- A. Provide manufacturer's limited lifetime warranty providing coverage for replacement of defective air admittance valves.

PART 2 - PRODUCTS

Insert the following under "Materials."

2.X MATERIALS

- A. Air Admittance Valves:
 1. Source: CHEM-VENT by Studor, Inc.
 2. Components:
 - a. Flame retardant polypropylene body.
 - b. Silicone seal on glass filled nylon stem.
 3. Features:
 - a. Screening inside and outside of valve to protect sealing membrane from solids.
 - b. Operating temperature: Minus 40 to plus 212 degrees F.
 - c. Suitable for use in non-neutralized chemical waste systems when system is designed by a design professional.

Edit the following to suit project requirements.

4. Connection size: [1-1/2 inch extended leg Schedule 40.] [As indicated on Drawings.]

PART 3 - EXECUTION

Insert the following under "Installation."

3.X INSTALLATION OF AIR ADMITTANCE VALVES

- A. Install valves after drainage and waste system has been roughed in and tested.
- B. Locate valves minimum 4 inches above horizontal branch drain or fixture drain being vented.
- C. Install valves in accessible locations.
- D. Connect valves to piping in accordance with manufacturer's instructions.
- E. Install valves in upright position, within 15 degrees of true vertical.
- F. Extend minimum of one vent to open atmosphere for each building drainage system.
- G. Do not install valves in supply and return air plenums.

Product Specifications

P.A.P.A.™

PART 1 - GENERAL

Insert the following under "References." Edit to include only those standards used elsewhere in the specification.

1.X REFERENCES

- A. American Society of Sanitary Engineering (ASSE)
 1. ASSE 1030 - Performance Requirements for Positive Pressure Reduction Devices for Sanitary Drainage Systems.
- B. International Association of Plumbing and Mechanical Officials (IAPMO) - Uniform Plumbing Code (UPC).
- C. International Code Council (ICC) - International Plumbing Code (IPC).
- D. ANSI/ASSE 1030.

If shop drawings, product data, or samples are desired, insert the following under "Submittals." Edit to include only those submittals actually required.

1.X SUBMITTALS

- A. Shop Drawings: Indicate air attenuator locations and required clear dimensions in spaces to receive air attenuators.
- B. Product Data: Include product description and installation instructions.
- C. Samples: Full size sample of air attenuator.

Insert the following under "Quality Assurance."

1.X QUALITY ASSURANCE

- A. Positive Air Pressure Attenuators: Approved for use as an Engineered Product or as part of an Engineered System under UPC, Section 301.2 - Alternate Materials and Methods or IPC, Section 300.
- B. ASSE 1030 Performance Requirements for Positive Pressure Reduction Devices for Sanitary Drainage Systems.

Insert the following under "Warranties."

1.X WARRANTIES

- A. Provide manufacturer's limited lifetime warranty providing coverage for replacement of defective air attenuators.

PART 2 - PRODUCTS

Insert the following under "Materials."

2.X MATERIALS

- A. Positive Air Pressure Attenuators:
 1. Source: P.A.P.A. by Studor, Inc.
 2. Components:
 - a. PVC housing.
 - b. Butylene bag.
 3. Features:
 - a. One gallon capacity.
 - b. Expandable capacity up to four gallons, series assembly.
 - c. Separator tubes.
 - d. Operating temperature: Minus 40 to plus 150 degrees F.

PART 3 - EXECUTION

Insert the following under "Installation."

3.X INSTALLATION OF POSITIVE TRANSIENT ATTENUATORS

Edit the following to suit project requirements. The P.A.P.A. may be installed horizontally or vertically and may also be installed in series for additional protection.

- A. Install P.A.P.A. after drainage and waste system has been roughed in and pressure tested.
- B. Install P.A.P.A. in accessible locations.
- C. Stack Installation: Connect units onto stack [vertically using one 90 degree or two 45 degree bends.] [horizontally using two 45 degree bends.]
- D. Branch Installation: Connect units onto branch [vertically using one 90 degree or two 45 degree bends.] [horizontally using two 45 degree bends.]
- E. Connect air attenuators to piping in accordance with manufacturer's instructions.

Product Specifications

Maxi-Filtra®

The following specification text has been prepared to assist design professionals in the preparation of a specification incorporating MAXI-FILTRA carbon filter by Studor, Inc. Utilize these paragraphs to insert text into Specification Section 15150 - Sanitary Waste and Vent Piping, or similarly titled section governing this work.

Editing notes to assist in the proper editing of the specifications are included as blue text. Delete these notes from the final specification.

Websites listed in the editing notes are hypertext links; while connected to the Internet, simply click on the underlined text to go to the applicable web page.

For assistance on the use of the products in this section, contact Studor, Inc.

PART 1 - GENERAL

Insert the following under "References." Edit to include only those standards used elsewhere in the specification.

1.X SUBMITTALS

- A. Shop Drawings: Indicate filter locations and filter sizes.
- B. Product Data: Include product description, required maintenance, and installation instructions.
- C. Samples: Full size sample of filter.

Insert the following under "Warranties."

1.X WARRANTIES

- A. Provide manufacturer's limited lifetime warranty providing coverage for replacement of defective filter.

PART 2 - PRODUCTS

Insert the following under "Materials."

2.X MATERIALS

- A. Carbon Filter:
 1. Source: MAXI-FILTRA by Studor, Inc.
 2. Components:
 - a. ABS body.
 - b. Active Charcoal Filter replaceable cartridge
 - c. Rubber connector.
 3. Features:
 - a. UV inhibitor in resin compounds for exposure to sunlight.

Edit the following to suit project requirements.

4. Connection size: [3 inches.] [4 inches.] [As indicated on Drawings.]

PART 3 - EXECUTION

Insert the following under "Installation."

3.X INSTALLATION OF CARBON FILTER

- A. Install filter after drainage and waste system has been roughed in and tested.
- B. Install valves in accessible locations to allow for filter cartridge replacement.
- C. Connect valves to piping in accordance with manufacturer's instructions.
- D. Do not install valves on chemical waste systems or in supply and return air plenums.
- E. For Outdoor Installation Only.

Product Specifications

Trap-Vent®

PART 1 - GENERAL

Insert the following under "References." Edit to include only those standards used elsewhere in the specification.

1.X REFERENCES

- A. American Society of Sanitary Engineering (ASSE)
 1. Standard 1051— Performance Requirements for Individual and Branch Type Air Admittance Valves for Sanitary Drainage Systems.
- B. NSF International American National Standards Institute (NSF/ANSI) Standard 14 - Plastic Piping System Components and Related Materials.

If shop drawings, product data, or sample are desired, insert the following under "Submittals" Edit to include only those submittals actually required.

1.X SUBMITTALS

- A. Shop Drawings: Indicate valve location, valve size.
- B. Product Data: Include product description, drain fixture unit chart, and installation instructions.
- C. Samples: Full size sample of

Insert the following under "Quality Assurance."

1.X QUALITY ASSURANCE

- A. Air Admittance Valves:

Edit the following to indicate applicable building or plumbing code.

1. Approved for use under
2. Certified to NSF

Insert the following under "Warranties."

1.X WARRANTIES

- A. Provide manufacturer's limited lifetime warranty providing coverage for replacement of defective Trap-Vent.

PART 2 - PRODUCTS

Insert the following under "Materials."

2.X MATERIALS

- A. Air Admittance Valves
 1. Source: TRAP-VENT by Studor, Inc.
 2. Components:
 - a. UV stabilized ABS body with Synthetic rubber.
 - b. Available 1 ¼ and 1 ½ trap waste arm (specifier to select one).
 3. Features:
 - a. Reduces the noise of the fixture discharge; 20dB noise reduction compared to conventional trap systems.
 - b. Prevents the release of foul air from the drainage system.
 - c. Compact size, enabling installation where space is restricted.
 - d. Height adjustable for fully flexible installation.
 - e. High grade integrated self-cleaning ability.
 - f. Operating temperature: +32 degree F to +150 degree F

Edit the following to suit project requirements.

4. Connection Sizes:
 - a. 1 ¼ trap waste arm
 - b. 1 ½ trap waste arm

PART 3 - EXECUTION

Insert the following under "Installation"

2.X INSTALLATION OF TRAP-VENT

- A. Code compliance will vary per State and Municipality –please verify with local code before installing.
- B. For use only in Residential lavatory bathroom installation – up to 6 drain fixture units.
- C. Cannot be installed on Kitchen sinks.
- D. Cannot be installed on laundry tubs /sinks.
- E. Cannot be installed on a sink that receives a discharge from any kind of appliance.
- F. Trap-vent must be accessible.
- G. Do not install Trap-Vent on a Chemical waste system.
- H. Connect Trap-vent to piping according to the manufacturer's instructions.

Product Reference / Technical Assistance

STUDOR is the world recognized leader in innovative DWV venting products and designs, our Air Admittance Valves and Positive Pressure Reducing device are designed for many different applications.

For over 40 years, Studor air admittance valve technology has been installed in various buildings throughout the world.

Types of projects:

Airports	Stadiums	Hotels
Hospitals	Residential Houses	Condominiums
Townhouses	Apartments	Institutional Facilities
Multi-Story Buildings	Marine Industry	Governmental Facilities

For a complete list of USA and International projects, please visit:
<http://www.ipscorp.com/plumbing/studor/reference/projects>

Technical Assistance and Training

With each **Studor Single Pipe System (SSPS)** project, Studor will provide:

- Assistance with the drawings to the engineers to ensure a properly designed Studor system
- Assistance with the drawings to the contractor on design-build projects to ensure a properly designed Studor system
- Training for the Mechanical/Plumbing contractor
- Training for the Plumbing Official's and Plumbing Inspector's
- Job-site walk through to assure proper installation

Note: Studor offers this service at no charge

STUDOR Advantage

Studor has the answer for all your needs, with the Studor brand products.

New Construction: “Studor Single Pipe System (SSPS)”

- Reduces the number of roof penetrations
- Reduces the possibility of water leaks around roof flashings
- Reduces structural damage caused by holes drilled through joists & studs used to install open vent piping
- Minimizes core drilling, floor penetrations and fire stopping devices
- Reduces vent pipes interfering with the roof finish & appearance
- Increases contractor’s productivity
- Eliminates design restrictions
- Cost Savings

STUDOR Problem Solving

Studor assists in solving issues with conventional plumbing systems as well as other existing drain waste and vent (DWV) systems throughout the world.

Sewer gas issues:

- Roof top Air Handler: Code requires open vent pipes to be a certain distance from the air handler, with the winds the sewer gas odors can still find their way to the air handler
- Parapet roof: Sewer gases from open vent pipes, get caught in the roof top area and then comes into the building through the bathroom vent fan duct, etc.
- Roof top Terrace: Hotel’s, Condo’s, Apartments, etc. with open vents are exposed to sewer gas odors
- Note: With Studor brand air admittance valves we can eliminate your sewer gas issues.

Positive Pressure Issues:

Positive transients can occur within a DWV system due to various reasons or situations. The Studor **P.A.P.A.**™ (Positive Air Pressure Attenuator) is designed to eliminate or to reduce the shock waves to a manageable level which are formed in multi-story to high-rise buildings.

Warranty

All STUDOR products carry a limited lifetime warranty, which guarantees that the products will be free of defects resulting from faulty workmanship or materials for a period corresponding to the lifetime of the original drainage system in which it is installed. If any such product is found to be defective by reason of faulty workmanship or materials, upon written notice and return of the product(s), the defective product(s) will at STUDOR's option be either repaired or replaced free of charge, including the cost of shipping for the repaired or replacement product(s).

This warranty does not apply where:

- The product has been accidentally damaged, abused, misused, improperly installed or improperly maintained;
- Disassembly, repairs or modifications have been made or attempted by persons other than those authorized to carry out such works by STUDOR or where there has been failure to install the product in accordance with STUDOR's recommended installation instructions;
- Circumstances beyond the control of STUDOR cause the product to no longer operate correctly including without limitation to natural disaster, severe adverse weather conditions or abnormal mechanical or environmental conditions;
- STUDOR P.A.P.A. devices are used in conjunction with non-STUDOR brand air admittance valves (such use will void the warranty in respect of the P.A.P.A. unit itself, as well as any other components used in the relevant system).

Claims for labor costs and other expenses required to replace such defective products or to repair any damage resulting from the use thereof will not be covered by this warranty. STUDOR's liability is limited to the price paid for the defective product(s) (although nothing in these terms and conditions shall exclude or limit our liability for death or personal injury arising from our negligence or any other liability that we are prohibited from excluding or restricting by law). Subject as expressly provided herein, all warranties, conditions or other terms implied by statute or common law are excluded to the fullest extent permitted by law.

This literature is published in good faith and is believed to be reliable. However, STUDOR does not represent and/or warrant in any manner the information and suggestions contained in this manual. Data presented is the result of laboratory tests and field experiences.

STUDOR maintains a policy of ongoing product improvement. This may result in modification of features, dimensions and/or specifications without notice.



IPS
CORPORATION®

500 Distribution Parkway
Collierville, TN 38017
www.ipscorp.com
1-800-888-8312
Fax: 1-901-853-5008