

# PRODUCT SPECIFICATION DRAWING

## QUICK STAND™ #50-SWHP-M

### Suspended Water Heater Platform

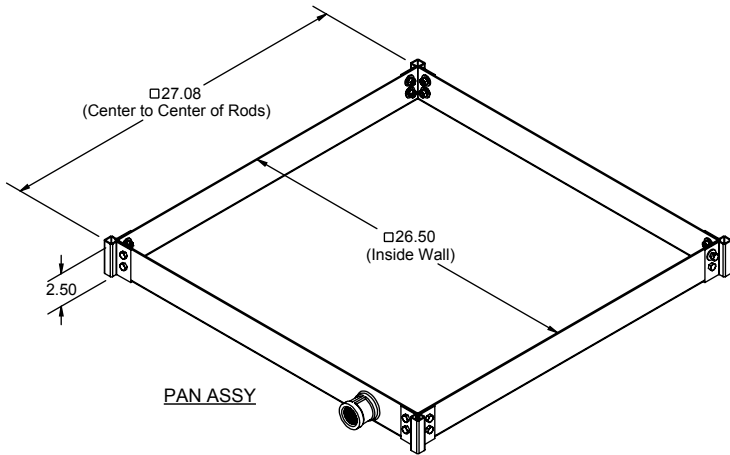

ALL DIMENSIONS IN INCHES

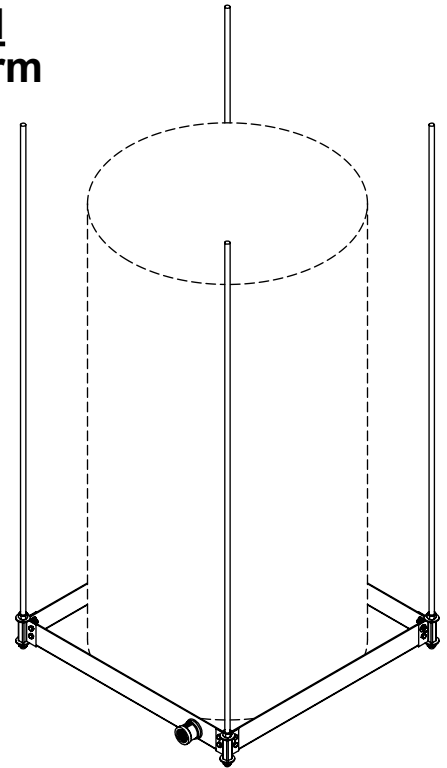

FULLY ASSEMBLED

**The Suspended Water Heater Platform is engineered to support water heaters up to 50 U.S. gallons (up to 600 pounds total weight). This time and labor savings tool is designed for the Professional Contractor. Design features requested by plumbers are incorporated into a professional platform that can be suspended with all thread rod. See Installation Instructions for detail.**

**Product Information:**

- Material:
  - Pan: 12 gage CRS, galvanized
  - Corner Brackets: 14 gage CRS, galvanized
- Wide platform allows water heaters up to 26-1/2" diameter
- Watertight corners and welded 1" steel drain body eliminate need for additional drain pan
- Static load rating 600 pounds with 2X safety factor (depending on structural anchorage)
- Galvanized steel construction
- Suspends with user supplied 3/8" or 1/2" threaded rod and hardware
- Four corner attachment points allows for seismic/sway bracing connection
- Patent pending

THIS INFORMATION IS PROPRIETARY TO HOLDRITE AND IS SUBJECT TO CHANGE WITHOUT NOTICE. IT MAY NOT BE REPRODUCED IN PART OR WHOLE WITHOUT WRITTEN AUTHORIZATION.



800-321-0316 OR 760-744-6944 / FAX: 760-744-0507 / WWW.HOLDRITE.COM  
spec\_50-SWHP-M\_RevE

Product Submittal	
Job Name:	
Date:	
Part Number:	Qty:
Architect / Owner:	
Contractor:	
Notes:	