

PRODUCT SPECIFICATION DRAWING

QUICKSTAND™ 21-1/2" X 21-1/2" (Water Heater & Equipment Support)

#40-S-22-A (assembled) and #40-S-22-U (unassembled)

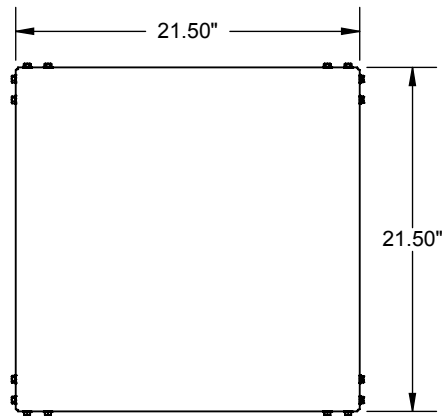
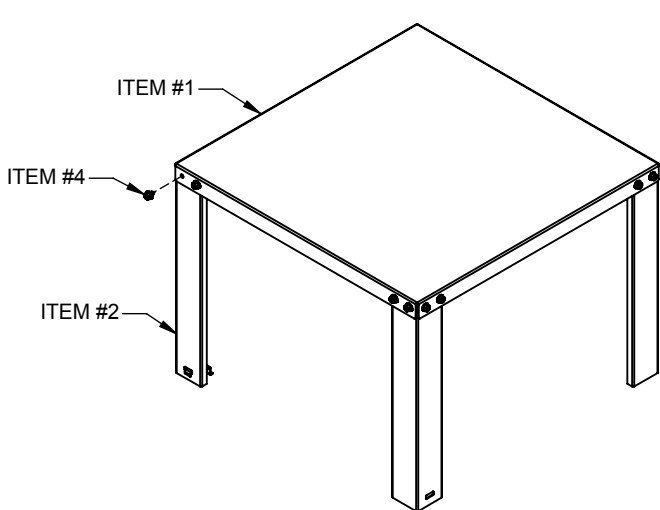

ALL DIMENSIONS IN INCHES

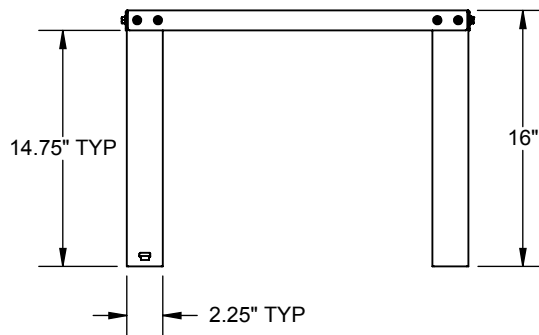

The QUICKSTAND™ #40-S-22- (A or U) stands safely elevates water heaters and other equipment above the floor (900 lbs rating).

Product Information:

- Material:
 - Item #1: Top, 14 gage CRS, galvanized
 - Item #2: Leg, 16 gage CRS, galvanized, 4 places
 - Item #3: Safety Clip, 14 gage CRS, galvanized, 2 places
 - Item #4: Screw, PH, Sems, #1/4 X 1/2"L (w / external starwasher), 16 places
 - Item #5: Lag Bolt, #1/4 X 2-1/2"L, self-drilling, 2 places (items #3 and #5 included with product)
- Engineered and lab tested to meet Uniform Plumbing Code (UPC) and International Plumbing Code (IPC) requirements, including elevation of water heater's ignition source 18" above the floor
- Holds up to 900 pounds capacity (up to 65 U.S. gallon tanks)
- QUICKSTAND™ weight 17-1/2 pounds without packaging
- Available in assembled and unassembled configurations



THIS INFORMATION IS PROPRIETARY TO HOLDRITE AND IS SUBJECT TO CHANGE WITHOUT NOTICE. IT MAY NOT BE REPRODUCED IN PART OR WHOLE WITHOUT WRITTEN AUTHORIZATION.



CONVERTING MAKESHIFT METHODS INTO ENGINEERED SOLUTIONSSM

\800-321-0316 OR 760-744-6944 / FAX: 760-744-0507 / WWW.HOLDRITE.COM
spec_40-S-22_RevH

Product Submittal	
Job Name:	
Date:	
Part Number:	Qty:
Architect / Owner:	
Contractor:	
Notes:	