

PVC TRUE UNION BALL VALVES (SCH. 80)



| PART # | MODEL # | DESCRIPTION (SIZE) | INNER CARTON QTY. | MASTER CARTON QTY. | SELECT MODEL BELOW |
|---|--------------|----------------------------------|-------------------|--------------------|--------------------------|
| PVC TRUE UNION BALL VALVES - SCH. 80 | | | | | |
| H55530 | HPTUBVPVC12 | 1/2" PVC TRUE UNION BALL VALVE | 1 | 48 | <input type="checkbox"/> |
| H55531 | HPTUBVPVC34 | 3/4" PVC TRUE UNION BALL VALVE | 1 | 36 | <input type="checkbox"/> |
| H55532 | HPTUBVPVC1 | 1" PVC TRUE UNION BALL VALVE | 1 | 24 | <input type="checkbox"/> |
| H55533 | HPTUBVPVC114 | 1-1/4" PVC TRUE UNION BALL VALVE | 1 | 24 | <input type="checkbox"/> |
| H55534 | HPTUBVPVC112 | 1-1/2" PVC TRUE UNION BALL VALVE | 1 | 24 | <input type="checkbox"/> |
| H55535 | HPTUBVPVC2 | 2" PVC TRUE UNION BALL VALVE | 1 | 12 | <input type="checkbox"/> |
| H55536 | HPTUBVPVC212 | 2-1/2" PVC TRUE UNION BALL VALVE | 1 | 12 | <input type="checkbox"/> |
| H55537 | HPTUBVPVC3 | 3" PVC TRUE UNION BALL VALVE | 1 | 6 | <input type="checkbox"/> |
| H55538 | HPTUBVPVC4 | 4" PVC TRUE UNION BALL VALVE | 1 | 1 | <input type="checkbox"/> |

- Schedule 80 PVC
- PTFE Seats
- EPDM O-Rings
- Socket x Socket or FIP x FIP
- 2-1/2" - 4" Valves are Socket by Socket ONLY
- Valves are NSF Approved

| NO. | PART | MATERIAL | QTY. |
|-----|----------------|---------------------|------|
| 1 | BODY | UPVC, PP, PVDF, ABS | 1 |
| 2 | STEM O-RING | EPDM, FPM | 2 |
| 3 | STEM | UPVC, PP, PVDF, ABS | 1 |
| 4 | BALL | UPVC, PP, PVDF, ABS | 1 |
| 5 | SEAT SEAL | PTFE | 2 |
| 6 | CARRIER O-RING | EPDM, FPM | 1 |
| 7 | SEAL CARRIER | UPVC, PP, PVDF, ABS | 1 |
| 8 | UNION O-RING | EPDM, FPM | 2 |
| 9 | END CONNECTOR | UPVC, PP, PVDF, ABS | 2 |
| 10 | UNION NUT | UPVC, PP, PVDF, ABS | 2 |
| 11 | HANDLE | ABS, PP | 1 |
| 12 | INSERTED NUT | C3604 | 2.4 |

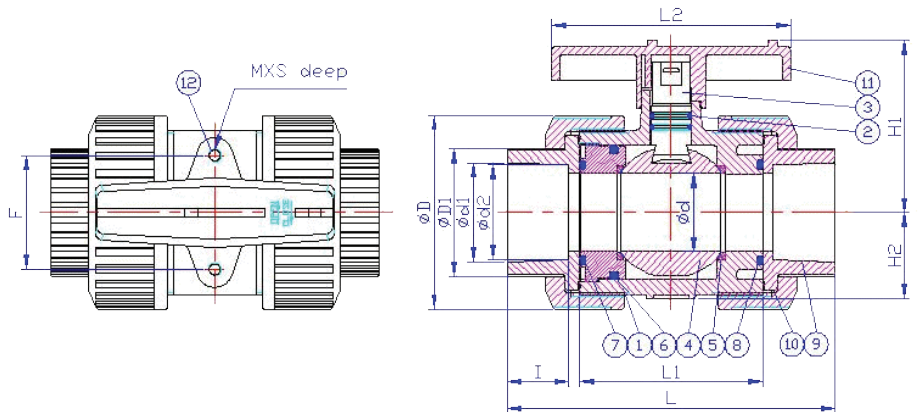

SEE CHART FOR DIMENSIONAL INFORMATION ON NEXT PAGE

JOB NAME: _____

JOB LOCATION: _____

CONTRACTOR: _____ DATE: _____

ENGINEER APPROVAL: _____ DATE: _____

ITEM TAG: _____

PART NUMBER: _____

PVC TRUE UNION BALL VALVES (SCH. 80)

| Size | 1/2" | 3/4" | 1" | 1 1/4" | 1 1/2" | 2" | 2 1/2" | 3" | 4" |
|------------------|------|------|------|--------|--------|------|--------|-------|-------|
| $\varnothing d1$ | 0.85 | 1.06 | 1.32 | 1.67 | 1.91 | 2.39 | 2.89 | 3.52 | 4.52 |
| $\varnothing d2$ | 0.84 | 1.05 | 1.31 | 1.66 | 1.89 | 2.37 | 2.87 | 3.49 | 4.49 |
| $\varnothing D$ | 1.83 | 2.17 | 2.60 | 3.23 | 3.86 | 4.72 | 5.51 | 6.42 | 8.86 |
| $\varnothing D1$ | 1.22 | 1.46 | 1.77 | 2.13 | 2.56 | 3.11 | 3.62 | 4.25 | 5.75 |
| $\varnothing d$ | 0.51 | 0.71 | 0.91 | 1.18 | 1.50 | 1.89 | 2.40 | 2.72 | 3.90 |
| H1 | 1.85 | 2.24 | 2.60 | 2.91 | 3.43 | 4.17 | 4.57 | 5.12 | 7.01 |
| H2 | 0.83 | 1.02 | 1.30 | 1.50 | 1.61 | 2.09 | - | - | - |
| I | 0.87 | 1.00 | 1.13 | 1.25 | 1.38 | 1.50 | 1.75 | 1.88 | 2.25 |
| L | 4.49 | 5.31 | 5.87 | 6.61 | 6.89 | 8.19 | 10.83 | 11.97 | 13.07 |
| L1 | 2.36 | 2.87 | 3.11 | 3.46 | 3.74 | 4.49 | 5.43 | 6.22 | 6.93 |
| L2 | 3.07 | 3.62 | 3.94 | 4.33 | 4.76 | 5.79 | 7.09 | 8.82 | 10.94 |
| Thd./in. NPT | 14 | 14 | 11.5 | 11.5 | 11.5 | 11.5 | 8* | 8* | 8* |
| S | 0.31 | 0.31 | 0.43 | 0.43 | 0.43 | 0.59 | - | - | - |
| F | 1.18 | 1.30 | 1.57 | 1.85 | 2.05 | 2.76 | - | - | - |
| M | M5 | M6 | M6 | M8 | M8 | M8 | - | - | - |
| Cv | 8 | 15 | 29 | 75 | 90 | 140 | 330 | 480 | 600 |

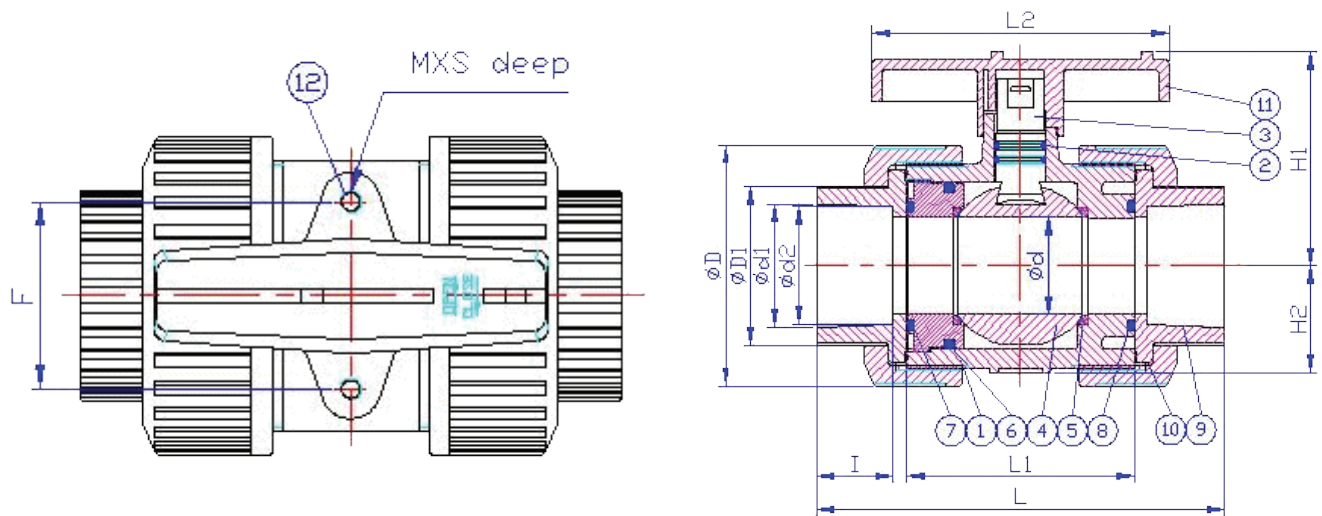

JOB NAME: _____

JOB LOCATION: _____

CONTRACTOR: _____ DATE: _____

ENGINEER APPROVAL: _____ DATE: _____

ITEM TAG: _____

PART NUMBER: _____