

# CR, CRI, CRN, CRT

Installation and operating instructions



**English (US)**  
Installation and operating instructions. . . . . 3

**Français (CA)**  
Notice d'installation et de fonctionnement. . . . . 35

**Español (MX)**  
Instrucciones de instalación y operación . . . . . 68

Original installation and operating instructions

**CONTENTS**

	<b>Page</b>		
<b>1. Limited warranty</b>	<b>3</b>	<b>16. Parts list</b>	<b>27</b>
<b>2. General information</b>	<b>4</b>	16.1 Spare parts	27
2.1 Hazard statements	4	<b>17. Preliminary electrical tests</b>	<b>28</b>
2.2 Notes	4	17.1 Supply voltage	28
<b>3. Introduction</b>	<b>4</b>	17.2 Current	28
<b>4. Receiving the product</b>	<b>5</b>	17.3 Insulation resistance	28
4.1 Transporting the product	5	<b>18. Startup of pump with air-cooled top (Cool-Top®)</b>	<b>29</b>
4.2 Receiving the product	5	<b>19. Diagnosing specific problems</b>	<b>30</b>
4.3 Lifting instructions	5	<b>20. Worksheet for three-phase motors</b>	<b>33</b>
4.4 Inspecting the product	5	<b>21. Disposal</b>	<b>34</b>
4.5 Ensure you have the right pump	5		
4.6 Pump end without motor	6		
4.7 Drive-end motor bearing	6		
<b>5. Identification</b>	<b>6</b>		
5.1 Nameplate data	6		
5.2 Type keys	7		
<b>6. Applications</b>	<b>10</b>		
<b>7. Operating conditions</b>	<b>10</b>		
7.1 Ambient temperature and altitude	10		
7.2 Liquid temperatures	10		
7.3 Minimum inlet pressures	10		
7.4 Maximum inlet pressures	11		
7.5 Maximum operating pressures	11		
<b>8. Mechanical installation</b>	<b>12</b>		
8.1 Lifting the product	12		
8.2 Pump location	12		
8.3 Outside installation	12		
8.4 Foundation	12		
8.5 Pump mounting	14		
8.6 Inlet pipe	14		
8.7 Outlet pipe	14		
8.8 Bypass	15		
8.9 Flange forces and torques	16		
8.10 Minimum continuous duty flow rates [gpm]	17		
8.11 Check valves	17		
8.12 Temperature rise	18		
<b>9. Electrical connection</b>	<b>18</b>		
9.1 Motors	19		
9.2 Position of terminal box	19		
9.3 Field wiring	19		
9.4 Motor protection	19		
<b>10. Starting up the product</b>	<b>20</b>		
10.1 Priming	20		
10.2 Startup instructions	21		
<b>11. Operating the product</b>	<b>21</b>		
11.1 Operating parameters	21		
11.2 Pump cycling	22		
11.3 Boiler feed installations	22		
11.4 Frost protection	22		
<b>12. Servicing the product</b>	<b>22</b>		
12.1 Contaminated products	22		
<b>13. Maintaining the pump</b>	<b>23</b>		
<b>14. Maintaining the motor</b>	<b>23</b>		
14.1 Motor inspection	23		
14.2 Motor lubrication	24		
<b>15. Replacing the motor</b>	<b>25</b>		
15.1 Disassembly	25		
15.2 Assembly	25		



Read this document before installing the product. Installation and operation must comply with local regulations and accepted codes of good practice.

**1. Limited warranty**

Products manufactured by Grundfos Pumps Corporation (Grundfos) are warranted to the original user only to be free of defects in material and workmanship for a period of 24 months from date of installation, but not more than 30 months from date of manufacture. Grundfos' liability under this warranty shall be limited to repairing or replacing at Grundfos' option, without charge, F.O.B. Grundfos' factory or authorized service station, any product of Grundfos manufacture. Grundfos will not be liable for any costs of removal, installation, transportation, or any other charges that may arise in connection with a warranty claim.

Products which are sold, but not manufactured by Grundfos, are subject to the warranty provided by the manufacturer of said products and not by Grundfos' warranty.

Grundfos will not be liable for damage or wear to products caused by abnormal operating conditions, accident, abuse, misuse, unauthorized alteration or repair, or if the product was not installed in accordance with Grundfos' printed installation and operating instructions and accepted codes of good practice. The warranty does not cover normal wear and tear.

To obtain service under this warranty, the defective product must be returned to the distributor or dealer of Grundfos' products from which it was purchased together with proof of purchase and installation date, failure date and supporting installation data. Unless otherwise provided, the distributor or dealer will contact Grundfos or an authorized service station for instructions. Any defective product to be returned to Grundfos or a service station must be sent freight prepaid; documentation supporting the warranty claim and/or a Return Material Authorization must be included if so instructed.

Grundfos will not be liable for any incidental or consequential damages, losses, or expenses arising from installation, use, or any other causes. There are no express or implied warranties, including merchantability or fitness for a particular purpose, which extend beyond those warranties described or referred to above. Some jurisdictions do not allow the exclusion or limitation of incidental or consequential damages and some jurisdictions do not allow limitations on how long implied warranties may last. Therefore the above limitations or exclusions may not apply to you. This warranty gives you specific legal rights and you may also have other rights which vary from jurisdiction to jurisdiction.

Products which are repaired or replaced by Grundfos or authorized service center under the provisions of these limited warranty terms will continue to be covered by Grundfos warranty only through the remainder of the original warranty period set forth by the original purchase date.

## 2. General information

### 2.1 Hazard statements

The symbols and hazard statements below may appear in Grundfos installation and operating instructions, safety instructions and service instructions.



#### **DANGER**

Indicates a hazardous situation which, if not avoided, will result in death or serious personal injury.



#### **WARNING**

Indicates a hazardous situation which, if not avoided, could result in death or serious personal injury.



#### **CAUTION**

Indicates a hazardous situation which, if not avoided, could result in minor or moderate personal injury.

The hazard statements are structured in the following way:



#### **SIGNAL WORD**

##### **Description of hazard**

Consequence of ignoring the warning.  
- Action to avoid the hazard.

### 2.2 Notes

The symbols and notes below may appear in Grundfos installation and operating instructions, safety instructions and service instructions.



Observe these instructions for explosion-proof products.



A blue or grey circle with a white graphical symbol indicates that an action must be taken.



A red or grey circle with a diagonal bar, possibly with a black graphical symbol, indicates that an action must not be taken or must be stopped.



If these instructions are not observed, it may result in malfunction or damage to the equipment.



Tips and advice that make the work easier.



#### **DANGER**

Indicates a hazardous situation which, if not avoided, will result in death or serious personal injury.



#### **WARNING**

Indicates a hazardous situation which, if not avoided, could result in death or serious personal injury.



#### **CAUTION**

Indicates a hazardous situation which, if not avoided, could result in minor or moderate personal injury.



#### **SIGNAL WORD**

##### **Description of hazard**

Consequence of ignoring the warning.  
- Action to avoid the hazard.

## 3. Introduction

The CR range is based on the inline multistage centrifugal pump first pioneered by Grundfos. CR is available in four basic materials and over one million configurations. CR is suitable for pumping water and water-like liquids in industry, petrochemical plants, water treatment plants, commercial buildings, and many other applications. Some of the outstanding characteristics of CR are:

- superior efficiency
- reliability
- easy maintenance
- compact size and small footprint
- quiet operation.

## 4. Receiving the product

### 4.1 Transporting the product

#### WARNING



##### Falling objects

- Death or serious personal injury
- Keep the product in a stable and fixed position during transportation.
  - Wear personal protective equipment.

### 4.2 Receiving the product

#### WARNING



##### Falling objects

- Death or serious personal injury
- Keep the product in a stable and fixed position during unpacking.
  - Wear personal protective equipment.

### 4.3 Lifting instructions

#### WARNING



##### Falling objects

- Death or serious personal injury
- Follow the lifting instructions.
  - Use lifting equipment which is approved for the weight of the product.
  - Persons must keep a safe distance to the product during lifting operations.
  - Wear personal protective equipment.



Do not use the lifting eyes of the motor for lifting the entire pump and motor assembly.



Note that typically the centre of gravity of the pump is close to the motor.

Lift pump assembly with lifting straps that pass through the motor stool. Ensure that the load is not applied to the pump shaft.

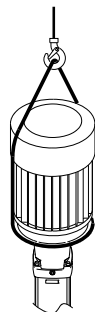

Fig. 1 Correct lifting of a CR pump

### 4.4 Inspecting the product

Before you install the product, do the following:

- Check that the product is as ordered.
- Check that no visible parts have been damaged during shipment.
- Ensure that the pump is NOT dropped or mishandled.

If parts are damaged or missing, contact your local Grundfos sales company.

The packing in which your pump arrived is specially designed for your pump to prevent damage during shipment. As a precaution, leave the pump in the packing until you are ready to install it. Installing the product

### 4.5 Ensure you have the right pump

Check the pump nameplate to make sure that it is the one you ordered.

- **CR:** Centrifugal pump; all parts in contact with the pumped liquid are made of standard cast iron and AISI 304 stainless steel
- **CRI:** Centrifugal pump; all parts in contact with the pumped liquid are made of AISI 304 stainless steel
- **CRN:** Centrifugal pump; all parts in contact with the pumped liquid are made of AISI 316 stainless steel
- **CRT:** Centrifugal pump; all parts in contact with the pumped liquid are made of titanium
- **CRE:** Centrifugal pump with a Grundfos MLE variable frequency drive motor.

TM04 0339 0608

## 4.6 Pump end without motor



If the shipment consists of a complete unit (motor attached to pump end), the position of the coupling connecting the pump shaft to the motor shaft is set to factory specifications. No adjustment is required.

If the shipment is a pump end without motor, follow the adjustment procedures in section [15. Replacing the motor](#).

### Pump without motor (CR, CRI, CRN 1s, 1, 3, 5, 10, 15, and 20 only)

If you purchased a pump end without motor, the shaft seal has been set from factory. Do not loosen the three set screws on the shaft seal when attaching the motor.

### Pump without motor (CR, CRN 32, 45 and 64 only)

If you purchased a pump end without motor, you must install the shaft seal. The shaft seal is protected in its own box inside the pump packing crate. To protect the shaft and bearings during shipment, a transport protector is used. Remove the transport protector prior to installation of the shaft seal. Read the seal installation instructions which are included in the pump packing.

## 4.7 Drive-end motor bearing

Make sure to use the correct type of drive-end (DE) motor bearing for the bare-shaft pump. Please check the specific pump range and pump version stated on the nameplate and select the corresponding DE bearing.

### DE bearing CR 1-64 pump range

Pump version <sup>1)</sup>	Deep-groove ball bearing (62/63xx)	Angular contact bearing (73xx)
A Standard pump	0.33 - 10 HP	15 - 60 HP
T Pump with thrust handling device (THD) <sup>2)</sup>	-	-
Z Pump with bearing flange <sup>2)</sup>	0.33 - 60 HP	Not allowed

<sup>1)</sup> Refer to the codes for pump version in section [5.2 Type keys](#).

<sup>2)</sup> Factory product variants (FPV).

## 5. Identification

### 5.1 Nameplate data

The information on the pump nameplate is described below.

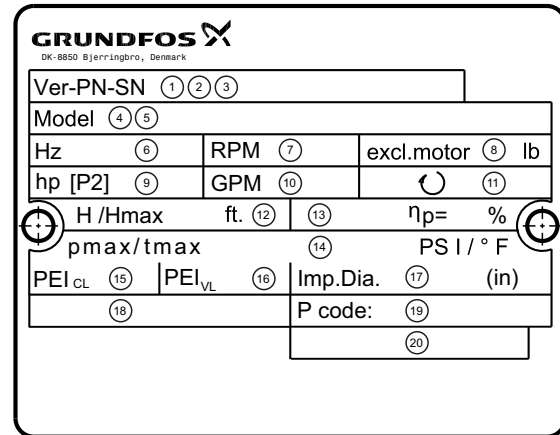

TM07 5722 5019

Fig. 2 Nameplate example

Pos.	Description
1	Version
2	Product number
3	Serial number
4	Model
5	Type designation
6	Frequency
7	Rated speed
8	Weight excluding motor
9	Motor-rated power output
10	Rated flow rate
11	Direction of rotation CCW: Counterclockwise CW: Clockwise
12	Head at rated flow rate / Maximum head
13	Hydraulic efficiency at rated flow rate
14	Maximum system pressure / Maximum liquid temperature. Note: This field may have two sets of data.
15	Pump Energy Index, constant load
16	Pump Energy Index, variable load
17	Impeller diameter
18	External reference (Other Equipment Manufacturer number)
19	Production code
20	Country of origin
21	Approval marks

## 5.2 Type keys

### 5.2.1 CR, CRI, CRN 1s, 1, 3, 5, 10, 15, and 20

Example	CR 3- 10 A FG A E HQQE
Type range: CR, CRI, CRN	
Rated flow rate in [m <sup>3</sup> /h] (x 5 gpm)	
Number of impellers	
Code for pump version	
Code for pipe connection	
Code for materials	
Code for rubber parts	
Code for shaft seal	

### 5.2.2 CR, CRN 32, 45 and 64

Example	CR 32- 2- 1 A G A E KUBE
Pump range: CR, CRN	
Rated flow rate in [m <sup>3</sup> /h] (x 5 gpm)	
Number of impellers	
Number of reduced-diameter impellers	
Code for pump version	
Code for pipe connection	
Code for materials	
Code for rubber parts	
Code for shaft seal	

### 5.2.3 CRT 2, 4, 8, and 16

Example	CRT 16- 30 /2 A G A AUUE
Pump range: CRT	
Rated flow rate in [m <sup>3</sup> /h] (x 5 gpm)	
Number of stages x 10	
Code for impellers (used only if the pump has fewer impellers than stages)	
Code for pump version	
Code for pipe connection	
Code for materials	
Code for shaft seal and rubber parts	

## 5.2.4 Codes

Example	A	-G	-A	-E	-H	QQ	E
<b>Pump version</b>							
A	Basic version <sup>1)</sup>						
B	Oversize motor						
E	Certificate/approval						
F	CR pump for high temperatures (air-cooled top assembly)						
H	Horizontal version						
HS	High-pressure pump with high-speed MLE motor						
I	Different pressure rating						
J	Pump with different max. speed						
K	Pump with low NPSH						
M	Magnetic drive						
N	Fitted with sensor						
P	Undersize motor						
R	Horizontal version with bearing bracket						
SF	High-pressure pump						
T	Oversize motor (two flange sizes bigger)						
U	NEMA version <sup>1)</sup>						
X	Special version <sup>2)</sup>						
<b>Pipe connection</b>							
A	Oval flange, Rp thread						
B	Oval flange, NPT thread						
CA	FlexiClamp (CRI(E), CRN(E) 1, 3, 5, 10, 15, 20)						
CX	Triclamp (CRI(E), CRN(E) 1, 3, 5, 10, 15, 20)						
F	DIN flange						
G	ANSI flange						
J	JIS flange						
N	Changed diameter of ports						
P	PJE coupling						
X	Special version						
<b>Materials</b>							
A	Basic version						
D	Carbon-graphite filled PTFE (bearings)						
G	Wetted parts, AISI 316						
GI	All parts stainless steel, wetted parts, AISI 316						
I	Wetted parts, AISI 304						
II	All parts stainless steel, wetted parts, AISI 304						
K	Bronze (bearings)						
S	SiC bearings + PTFE neck rings						
X	Special version						
<b>Code for rubber parts</b>							
E	EPDM						
F	FXM						
K	FFKM						
V	FKM						



Example		A	-G	-A	-E	-H	QQ	E
<b>Shaft seal</b>								
A	O-ring seal with fixed driver							
B	Rubber bellows seal							
E	Cartridge seal with O-ring							
H	Balanced cartridge seal with O-ring							
K	Metal bellows cartridge seal							
O	Double seal, back-to-back							
P	Double seal, tandem							
X	Special version							
B	Carbon, synthetic resin-impregnated							
H	Cemented tungsten carbide, embedded (hybrid)							
Q	Silicon carbide							
U	Cemented tungsten carbide							
X	Other ceramics							
E	EPDM							
F	FXM							
K	FFKM							
V	FKM							

- 1) In August 2003 the NEMA version pump code was discontinued for all material numbers created by Grundfos manufacturing companies in North America. The NEMA version pump code will still remain in effect for existing material numbers. NEMA version pumps built in North America after this change will have either an A or a U as the pump version code depending on the date the material number was created.
- 2) If a pump incorporates more than two pump versions, the code for the pump version is X. X also indicates special pump versions not listed above.

## 6. Applications

Compare the pump's nameplate data or its performance curve with the application in which you plan to install it. Make sure the application falls within the following limits.

Type	Application/liquid
CR	Hot and chilled water, boiler feed, condensate return, glycols and solar thermal liquids.
CRI/CRN	Deionized, demineralized and distilled water. Brackish water and other liquids unsuitable for contact with iron or copper alloys. (Consult manufacturer for specific liquid compatibilities.)
CRN-SF	High-pressure washdown, reverse osmosis or other high-pressure applications.
CRT	Salt water, chloride based liquids and liquids approved for titanium.

## 7. Operating conditions

### 7.1 Ambient temperature and altitude

If the ambient temperature exceeds the maximum temperature limits of the pump or the pump is installed at an altitude exceeding the altitude values in the chart below, the motor must not be fully loaded due to the risk of overheating.

Overheating may result from excessive ambient temperatures or the low density and consequently low cooling effect of the air at high altitudes. In such cases, it may be necessary to use a motor with a higher rated output (P<sub>2</sub>).

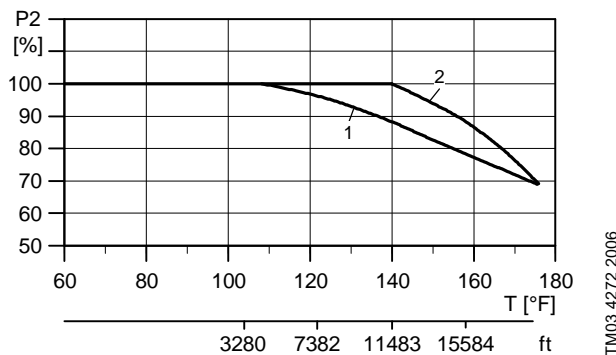

**Fig. 3** Relationship between motor output (P<sub>2</sub>) and ambient temperature/altitude

### Legend

Pos.	Description
1	NEMA standard-efficiency motors
2	NEMA premium-efficiency motors

**Example:** From fig. 3 it appears that P<sub>2</sub> must be reduced to 88 % when a pump with a NEMA premium-efficiency ML motor is installed 15,584 feet above sea level. At an ambient temperature of 167 °F, P<sub>2</sub> of a standard-efficiency motor must be reduced to 74 % of rated output.

In cases where both the maximum temperature and the maximum altitude are exceeded, the derating factors must be multiplied.

Example: 0.89 x 0.89 = 0.79.

## 7.2 Liquid temperatures

Pump	Liquid temperature
CR, CRI, CRN 1s, 3, 5, 10, 15, and 20	-4 to +248 °F (-20 to +120 °C)
CR, CRN 32, 45 and 64*	-22 to +248 °F (-30 to +120 °C)
CRT 2, 4, 8, 16	-4 to +248 °F (-20 to +120 °C)
CRN-SF	-4 to +221 °F (-15 to +105 °C)
Pumps with Cool-Top™	up to 356 °F (180 °C)

All motors are designed for continuous duty in 104 °F (40 °C) ambient air conditions. For higher ambient temperature conditions, consult Grundfos.

\* We recommend xUBE shaft seals for temperatures above 200 °F. Pumps with KUHE hybrid shaft seals can only operate up to 200 °F (90 °C). Pumps with xUUE shaft seals can be operated down to -40 °F (-40 °C). ("x" is the seal type).



Maximum water temperature for NSF 61 drinking water applications is limited to 73 °F (23 °C).

## 7.3 Minimum inlet pressures

All CR, CRI, CRN	NPSHR + 2 feet
CRN-SF	29 psi (2 bar)

## 7.4 Maximum inlet pressures

Pump type	Stages		Max. [psi (bar)]
	60 Hz	50 Hz	
CR, CRI, CRN 1s	2-27	2-36	145 (10)
CR, CRI, CRN 1	2-25	2-36	145 (10)
	27		217 (15)
CR, CRI, CRN 3	2-17	2-29	145 (10)
	19-25	31-36	217 (15)
CR, CRI, CRN 5	2-9	3-16	145 (10)
	10-24	18-36	217 (15)
CR, CRI, CRN 10	1-5	1-6	116 (8)
	6-17	7-22	145 (10)
CR, CRI, CRN 15	1-2	1-3	116 (8)
	3-12	4-17	145 (10)
CR, CRI, CRN 20	1	1-3	116 (8)
	2-10	4-17	145 (10)
CR, CRN 32	1-1 - 2	1-1 - 4	58 (4)
	3-2 - 6	5-2 - 10	145 (10)
	7-2 - 11-2	11-14	217 (15)
CR, CRN 45	1-1 - 1	1-1 - 2	58 (4)
	2-2 - 3	3-2 - 5	145 (10)
	4-2 - 8-1	6-2 - 13-2	217 (15)
CR, CRN 64	1-1	1-1 - 2-2	58 (4)
	1 - 2-1	2-1 - 4-2	145 (10)
	2 - 5-2	4-1 - 8-1	217 (15)
CRT 2	2-6	2-11	145 (10)
	7-18	13-26	217 (15)
CRT 4	1-7	1-12	145 (10)
	8-16	14-22	217 (15)
CRT 8	1-16	1-20	145 (10)
CRT 16	2-10	2-16	145 (10)
CRN-SF	all	all	72 (5)* 362 (25)**

\* While pump is off or during start-up.

\*\* During operation.

## 7.5 Maximum operating pressures

250 °F (194 °F for CRN-SF)

Pump type/ connection	Stages		Max. [psi (bar)]
	60 Hz	50 Hz	
<b>CR, CRI, CRN 1s</b>			
Oval flange	1-17	1-23	232 (16)
FGJ, PJE	1-27	1-36	362 (25)
<b>CR, CRI, CRN 1</b>			
Oval flange	1-17	1-23	232 (16)
FGJ, PJE	1-27	1-36	362 (25)
<b>CR, CRI, CRN 3</b>			
Oval flange	1-17	1-23	232 (16)
FGJ, PJE	1-27	1-36	362 (25)

Pump type/ connection	Stages		Max. [psi (bar)]
	60 Hz	50 Hz	
<b>CR, CRI, CRN 5</b>			
Oval flange	1-16	1-22	232 (16)
FGJ, PJE	1-24	1-36	362 (25)
<b>CR, CRI 10</b>			
Oval flange CR	1-6		145 (10)
Oval flange, CRI	1-10	1-16	232 (16)
FGJ, GJ, PJE	1-10	1-16	232 (16)
FGJ, GJ, PJE	12-17	17-22	362 (25)
<b>CRN 10</b>			
All	1-17	1-22	362 (25)
<b>CR, CRI 15</b>			
Oval flange	1-5	1-7	145 (10)
FGJ, GJ, PJE	1-8	1-10	232 (16)
FGJ, GJ, PJE	9-12	12-17	362 (25)
<b>CRN 15</b>			
All	1-12	1-17	362 (25)
<b>CR, CRI 20</b>			
Oval flange	1-5	1-7	145 (10)
FGJ, GJ, PJE	1-7	1-10	232 (16)
FGJ, GJ, PJE	8-10	12-17	362 (25)
<b>CRN 20</b>			
All	1-10	1-17	362 (25)
<b>CR, CRN 32</b>			
	1-1 - 5	1-1 - 7	232 (16)
	6-2 - 11-2	8-2 - 14	435 (30)
<b>CR, CRN 45</b>			
	1-1 - 4-2	1-1 - 5	232 (16)
	4-2 - 8-1	6-2 - 13-2	435 (30)
<b>CR, CRN 64</b>			
	1-1 - 3	1-1 - 5	232 (16)
	4-2 - 5-2	6-2 - 8-1	435 (30)
CRT 2	2-18	2-26	305 (21)
CRT 4	1-16	1-22	305 (21)
<b>CRT 8</b>			
	1-8	1-12	232 (16)
	10-16	14-20	362 (25)
<b>CRT 16</b>			
	1-8	1-8	232 (16)
	10-12	10-16	362 (25)

Consult Grundfos in case of other operating conditions.

## 8. Mechanical installation

### WARNING

#### Contamination when pumping drinking water

Death or serious personal injury

- Before the pump is used for supplying drinking water, flush the pump thoroughly with clean water.
- Do not use the pump for drinking water if the internal parts have been in contact with particles or substances not suitable for water intended for human consumption.



The pump must be installed according to national water regulations and standards.

### 8.1 Lifting the product

### WARNING

#### Falling objects

Death or serious personal injury

- Follow the lifting instructions.
- Use lifting equipment which is approved for the weight of the product.
- Persons must keep a safe distance to the product during lifting operations.
- Wear personal protective equipment.



For lifting instructions, see section [4.3 Lifting instructions](#).

### 8.2 Pump location

Locate the pump in a dry, well-ventilated, frost-free area which is not subject to extreme variation in temperature.

Make sure the pump is mounted at least 6 inches (150 mm) clear of any obstruction or hot surfaces.

The motor requires an adequate air supply to prevent overheating and adequate vertical space to remove the motor for repair.

In open systems requiring suction lift, locate the pump as close to the liquid source as possible to reduce friction loss in pipes.

### 8.3 Outside installation

Grundfos recommends that pumps installed outside have rain cover for the motor and remove, at a minimum, one of the motor drain plugs. Failure to remove a motor drain plug will result in condensation in the motor and cause motor damage or failure.

Grundfos recommends that you consult the motor manufacturer's installation and operation instructions.

### 8.4 Foundation

Use concrete or similar foundation material to provide a secure, stable mounting base for the pump.

See table below for bolt hole center line dimensions for the various pump types.

Secure the pump to the foundation using all four bolts and shim pump base to assure the pump is vertical and all four pads on the base are properly supported (uneven surfaces can result in pump base breakage when mounting bolts are tightened).

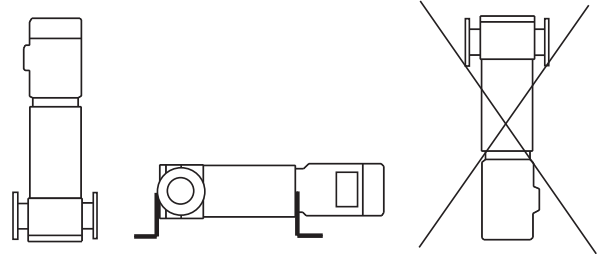

Fig. 4 Pump position

The pump can be installed vertically or horizontally. See fig. 4.

Ensure that an adequate supply of cool air reaches the motor cooling fan. The motor must never fall below the horizontal plane.

Arrows on the pump base show the direction of flow of liquid through the pump.

To minimize possible noise from the pump, it is advisable to fit expansion joints on either side of the pump and anti-vibration mountings between the foundation and the pump.



Make sure the vent plug is located in the uppermost position.

Fit isolating valves on either side of the pump to avoid draining the system if the pump needs to be cleaned, repaired or replaced.

TM04 3906 0409

Base and bolt hole center line dimensions

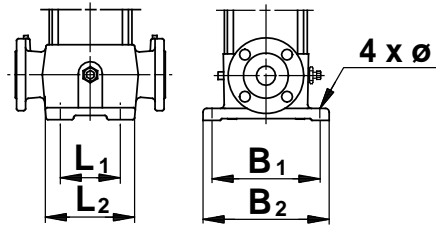

TM00 2256 3393

Pump type	L1		L2		B1		B2		Ø	
	[inches]	[mm]	[inches]	[mm]	[inches]	[mm]	[inches]	[mm]	[inches]	[mm]
CR 1s, 1, 3, 5	3 15/16	100	5 11/16	145	7 1/16	180	8 11/16	220	1/2	13
CRI, CRN 1s 1, 3, 5 CRT 2, 4	3 15/16	100	5 7/8	150	7 1/16	180	8 11/16	220	1/2	13
CR 10, 15, 20	5 1/8	130	6 15/16	176	8 7/16	215	10 1/16	256	9/16	13.5
CRN 10, 15, 20 CRT 8, 16	5 1/8	130	7 7/8	200	8 7/16	215	9 3/4	248	1/2	13
CR 32	6 11/16	170	8 3/4	223	9 7/16	240	11 3/4	298	9/16	14
CRN 32	6 11/16	170	8 7/8	226	9 7/16	240	11 3/4	298	9/16	14
CR 45, 64	7 1/2	190	9 3/4	248	10 1/2	266	13 1/16	331	9/16	14
CRN 45, 64	7 1/2	190	9 7/8	251	10 1/2	266	13 1/16	331	9/16	14

### 8.5 Pump mounting

#### WARNING



#### Pressurised system

Death or serious personal injury  
 - The pumps are shipped with covered inlet and outlet ports. Remove the covers before the pipes are connected to the pump.

#### 8.5.1 Recommended installation torques

Pump type	Recommended foundation torque [ft-lbs]	Recommended flange torque [ft-lbs]
CR, CRI, CRN 1s/1/3/5 CRT 2/4	30	37-44
CR, CRI, CRN 10/15/20 CRT 8/16	37	44-52
CR, CRN 32/45/64	52	52-59

### 8.6 Inlet pipe

The inlet pipe should be adequately sized and run as straight and short as possible to keep friction losses to a minimum (minimum of four pipe diameters straight run prior to the inlet flange). Avoid using unnecessary fittings, valves or accessory items. Use butterfly valves in the inlet line only when it is necessary to isolate a pump because of a flooded inlet condition. This would occur if the water source is above the pump. See fig. 5 and fig. 6. Flush piping prior to pump installation to remove loose debris.

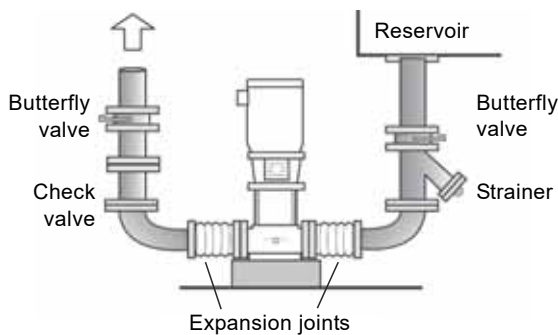

Fig. 5 Flooded inlet

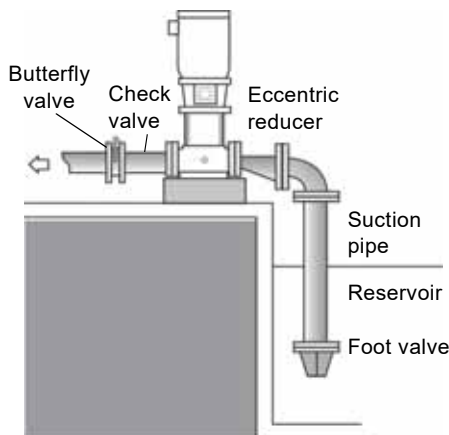

Fig. 6 Inlet lift\*

\* The inlet pipe should have a fitting on it for priming. CRN-SF pumps cannot be used for inlet lift.

### 8.6.1 Inlet pipe sizes

The following recommended inlet pipe sizes are the smallest sizes which should be used with any specific CR pump type. Verify the inlet pipe size in each installation to ensure that good pipe practices are being observed and excess friction losses are not encountered. High temperatures may require larger diameter pipes to reduce friction and improve NPHSA.

Pump type	Min. inlet pipe size	
CR, CRI, CRN 1s, 1, 3 CRT 2	1"	Nominal diameter acc. to ANSI schedule 40
CR, CRI, CRN 5 CRT 4	1 - 1/4"	Nominal diameter acc. to ANSI schedule 40
CR, CRI, CRN 10, 15, 20 CRT 8, 16	2"	Nominal diameter acc. to ANSI schedule 40
CR, CRN 32	2 - 1/2"	Nominal diameter acc. to ANSI schedule 40
CR, CRN 45	3"	Nominal diameter acc. to ANSI schedule 40
CR, CRN 64	4"	Nominal diameter acc. to ANSI schedule 40

### 8.7 Outlet pipe

We suggest to install a check valve and a isolating valve in the outlet pipe. Pipe, valves and fittings should be at least the same diameter as the outlet pipe or sized in accordance with good piping practices to reduce excessive flow velocities and friction losses in pipes.



The pressure rating of pipes, valves and fittings must be equal to or greater than the maximum system pressure.

Before installing the pump, pressure check the outlet piping to at least the maximum pressure the pump is capable of generating or as required by codes or local regulations.

Whenever possible, avoid high pressure-loss fittings, such as elbows or branch tees directly on either side of the pump. The piping should be adequately supported to reduce thermal and mechanical stresses on the pump.

According to good installation practices, clean the system thoroughly and flush it of all foreign materials and sediment prior to pump installation. Furthermore, never install the pump at the lowest point of the system due to the natural accumulation of dirt and sediment. If there is excessive sediment or suspended particles, we recommend that a strainer or filter is used. Grundfos recommends that pressure gauges are installed on inlet and outlet flanges or in pipes to monitor pump and system performance.



To avoid problems with water hammer, do not use quick-closing valves in CRN-SF applications.

### 8.8 Bypass

Install a bypass in the outlet pipe if there is any risk that the pump may operate against a closed valve in the outlet line. Flow through the pump is required to ensure that adequate cooling and lubrication of the pump is maintained. See [7.3 Minimum inlet pressures](#) for minimum flow rates.

Elbows should be at least 12" from the bypass opening to prevent erosion.

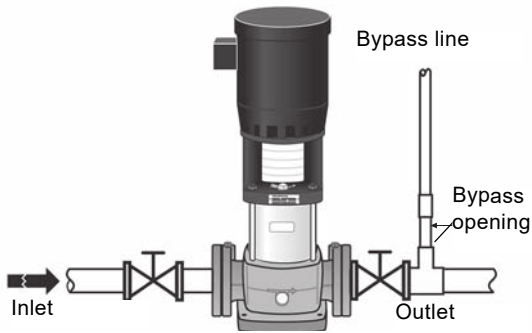

**Fig. 7** Recommended bypass arrangement

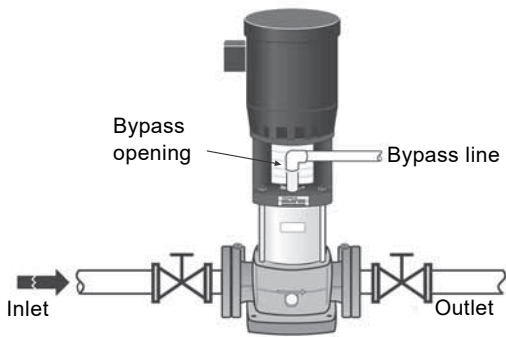

**Fig. 8** Optional bypass arrangement

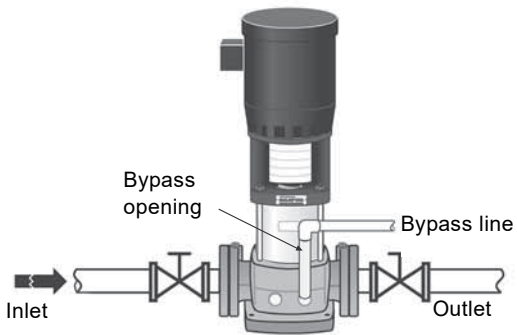

**Fig. 9** Optional bypass arrangement for CR, CRN 32, 45 and 64

## 8.9 Flange forces and torques

If not all loads reach the maximum permissible value stated in the tables after fig. 10, one of these values may exceed the normal limit. Contact Grundfos for further information.

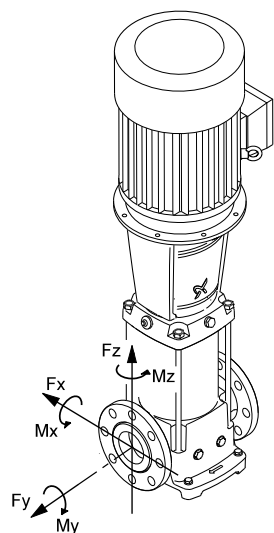

Y-direction: Inlet/outlet

Z-direction: Direction of chamber stack

X-direction: 90 ° from inlet/outlet

TM04 0346 2013

Fig. 10 Flange forces [F] and torques [M]

### Force limits

Flange		Pump	CR - Cast iron pump housing			CRI, CRN - Stainless steel pump housing		
ANSI [in]	DN [mm]	Type	Force, Y-direction [lb]	Force, Z-direction [lb]	Force, X-direction [lb]	Force, Y-direction [lb]	Force, Z-direction [lb]	Force, X-direction [lb]
1/ 1 1/4	25/32	1s-5	76	89	72	152	177	143
1 1/2	40	10	93	105	84	185	211	169
2	50	15, 20	127	131	114	253	261	228
2 1/2	65	32	156	177	143	312	354	287
3	80	45	211	173	190	421	346	379
4	100	64	282	228	253	565	455	506

### Torque limits

Flange		Pump	CR - Cast iron pump housing			CRI, CRN - Stainless steel pump housing		
ANSI [in]	DN [mm]	Type	Torque, Y-direction [ft-lb]	Torque, Z-direction [ft-lb]	Torque, X-direction [ft-lb]	Torque, Y-direction [ft-lb]	Torque, Z-direction [ft-lb]	Torque, X-direction [ft-lb]
1/ 1 1/4	25/32	1s-5	221	129	92	443	258	184
1 1/2	40	10	295	203	148	590	406	295
2	50	15, 20	332	240	184	664	479	369
2 1/2	65	32	369	258	221	738	516	443
3	80	45	240	295	406	479	590	811
4	100	64	277	350	461	553	701	922



## 8.10 Minimum continuous duty flow rates [gpm]

Pump type	min. °F to 176 °F (min. °C to 80 °C)	at 210 °F (at 99 °C)	at 248 °F (at 120 °C)	at 356 °F (at 180 °C)
CR, CRI, CRN 1s	0.5	0.7	1.2	1.2*
CR, CRI, CRN 1	0.9	1.3	2.3	2.3*
CR, CRI, CRN 3	1.6	2.4	4.0	4.0*
CR, CRI, CRN 5	3.0	4.5	7.5	7.5*
CR, CRI, CRN 10	5.5	8.3	14	14*
CR, CRI, CRN 15	9.5	14	24	24*
CR, CRI, CRN 20	11	17	28	28*
CR, CRN 32	14	21	35	35*
CR, CRN 45	22	33	55	55*
CR, CRN 64	34	51	85	85*
CRT 2	1.3	2.0	3.3	N/A
CRT 4	3.0	4.5	7.5	N/A
CRT 8	4.0	6.0	10	N/A
CRT 16	8.0	12	20	N/A

\* Grundfos Cool-Top® is only available in the following pump types:

Pump type	CR 1s	CR 1	CR 3	CR 5	CR 10	CR 15	CR 20	CR 32	CR 45	CR 64
Standard (CR)								•	•	•
I version (CRI)	•	•	•	•	•	•	•			
N version (CRN)	•	•	•	•	•	•	•	•	•	•

## 8.11 Check valves

A check valve may be required on the outlet side of the pump to prevent the pump inlet pressure from being exceeded.

When a pump with no check valve is stopped because there is no demand on the system (all valves are closed), the high system pressure on the outlet side of the pump will "find" its way back to the inlet of the pump.

This is especially critical for CRN-SF applications because of the very high outlet pressures involved. As a result, most CRN-SF installations require a check valve on the outlet piping.

## 8.12 Temperature rise

It may sometimes be necessary to stop the flow through a pump during operation.

When the flow is stopped, the power to the pump is transferred to the pumped liquid as heat, causing a temperature rise in the liquid.

The result is risk of overheating and consequent damage to the pump. The risk depends on the temperature of the pumped liquid and for how long the pump is operating without flow. See the following temperature rise table.

Pump type	Time for temperature rise of 18 °F (10 °C)	
	Seconds	Minutes
CR 1s, 1, 3	210	3.5
CR 5	240	4.0
CR 10	210	3.5
CR 15	150	2.5
CR 20	120	2.0
CR 32, 45, 64	-	-

### Conditions/reservations

The listed times are subject to the following conditions/reservations:

- No exchange of heat with the surroundings.
- The pumped liquid is water with a specific heat capacity of 1.0 Btu/lb. °F (4.18 kJ/kg °C).
- Pump parts (chambers, impellers and shaft) have the same heat capacity as water.
- The water in the base and the pump head is not included.

These reservations should give sufficient safety margin against excessive temperature rise.

The maximum temperature must not exceed the pump maximum temperature rating.

## 9. Electrical connection



All electrical work must be performed by a qualified electrician in accordance with the latest edition of the National Electrical Code and local codes and regulations.



Follow the instructions for the motor when carrying out the electrical connections.

### WARNING

#### Electric shock

Death or serious personal injury

- Before starting any work on the product, make sure that the power supply has been switched off and that it cannot be accidentally switched on.
- Connect the pump to an external main switch close to the pump and to a motor-protective circuit breaker or a CUE frequency converter. Make sure you can lock the main switch in OFF position (isolated). Type and requirements as specified in EN 60204-1, 5.3.2.



### WARNING

#### Electric shock

Death or serious personal injury

- The safe operation of this pump requires that it is grounded in accordance with the National Electrical Code and local codes and regulations.
- A faulty motor or faulty wiring can cause electric shock that could be fatal, whether the motor is touched directly or the current is conducted through standing water. For this reason, safe installation and operation require proper grounding of the pump to the power supply ground (earth) terminal.
- Connect the ground conductor to the grounding screw in the terminal box and then to the ACCEPTABLE grounding point.
- In all installations, connect the above-ground metal plumbing to the power supply ground terminal as described in Article 250-80 of the National Electrical Code.



### WARNING

#### Electric shock

Death or serious personal injury

- Connect the pump to the same protective-earth (PE) potential as the motor if both motor bearings are of the insulated type such as ceramic bearings..



Verify the power supply to make sure that the voltage, phases and frequency match those of the pump. The proper operating voltage and other electrical information appear on the motor nameplate. These motors are designed to run on - 10 %/+ 10 % of the rated nameplate voltage. For dual-voltage motors, the motor should be internally connected to operate on the voltage closest to the 10 % rating, i.e., a 208 V motor should be wired according to the 208 V wiring diagram. The wiring diagram can be found on either a plate attached to the motor or on a label inside the terminal box cover.



Do not operate the pump if voltage variations are greater than - 10 %/+ 10 %.

## 9.1 Motors

Grundfos CR pumps are supplied with heavy-duty, 2-pole (3600 rpm), ODP (open drip-proof) or TEFC (totally enclosed fan cooled), NEMA C frame motors selected to our rigid specifications.

Motors with other enclosure types and for other voltages and frequencies are available on a special-order basis.

CRN-SF pumps are supplied with an IEC (metric) type motor with a reverse thrust bearing.

If you replace the pump, but keep a motor previously used on another CR pump, be sure to read section [14. Maintaining the motor](#) for proper adjustment of the coupling height.

If you install the pump outside, read section [8.3 Outside installation](#).

## 9.2 Position of terminal box

The motor terminal box can be turned to any of four positions in steps of 90°.

To rotate the terminal box, remove the four bolts securing the motor to the pump but do not remove the coupling. Turn the motor to the desired position; replace and securely tighten the four bolts. See fig. 11.

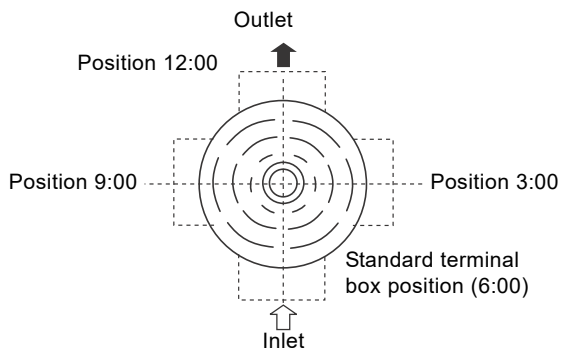

Fig. 11 Motor terminal box positions (top view)

## 9.3 Field wiring

Lead sizes should be based on the current carrying properties of conductors required by the latest edition of the National Electrical Code or local regulations. Direct-on-line (DOL) starting is approved due to the extremely short run-up time of the motor and the low moment of inertia of the pump and motor. If DOL starting is not acceptable and reduced starting current is required, use an auto transformer, resistance starter or soft starter. We suggest to use a fused disconnect for each pump in case standby pumps are installed.

## 9.4 Motor protection

### 9.4.1 Single-phase motors

All CR pumps with single phase motors, except 10 HP, are equipped with multi-voltage, squirrel cage induction motors which include built-in thermal protection.

### 9.4.2 Three-phase motors

CR pumps with three-phase motors must be used with the proper size and type of motor-protective circuit breaker to ensure the motor is protected against damage from low voltage, phase failure, current unbalance and overloads.

Use a properly sized circuit breaker with manual reset and ambient-temperature compensated extra-quick trip in all three phases. The overload protection should be set and adjusted to the full-load current rating of the motor. Under no circumstances should the overload protection be set to a higher value than the full-load current shown on the motor nameplate. This will void the warranty.

Set overload protection for auto transformers and resistance starters in accordance with the recommendations of the manufacturer.

Three-phase MLE motors (CRE-pumps) require only fuses as circuit breaker. They do not require a motor-protective circuit breaker. Check for phase unbalance (worksheet is provided. See section [20. Worksheet for three-phase motors](#)).



Standard allowable phase unbalance is 5 %.

### 9.4.3 CRN-SF

The CRN-SF is typically operated in series with a feed pump. Because the maximum allowable inlet pressure of the CRN-SF increases from 73 psi (when pump is off and during start-up) to 365 psi (during operation), use a control device to start the CRN-SF pump one second before the feed pump starts. Similarly, the CRN-SF must stop one second after the feed pump stops. See CRN-SF start-up timeline below.

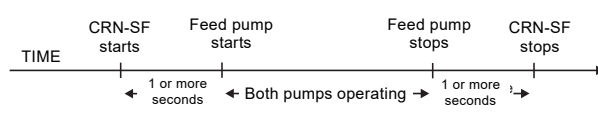

Fig. 12 CRN-SF start-up

## 10. Starting up the product

### WARNING



#### Corrosive liquids

Death or serious personal injury  
- Wear personal protective equipment.

### WARNING



#### Toxic liquids

Death or serious personal injury  
- Wear personal protective equipment.

### CAUTION



#### Hot or cold liquid

Minor or moderate personal injury  
- Wear personal protective equipment.  
- Pay attention to the direction of the vent hole when you fill the pump with liquid and vent it.  
- Make sure that no persons are hurt by the escaping liquid.



Fill the pump with liquid and vent it before you start the pump.



Pay attention to the direction of the vent hole during liquid filling and venting. Make sure that the escaping liquid does not cause damage to the motor or other components



If the pump runs dry, the pump bearings and the shaft seal may be damaged.

### 10.1 Priming

To prime the pump in a closed system or an open system where the water source is above the pump, close the pump isolating valve(s) and open the priming plug on the pump head. See fig. 13, fig. 14, and fig. 15.

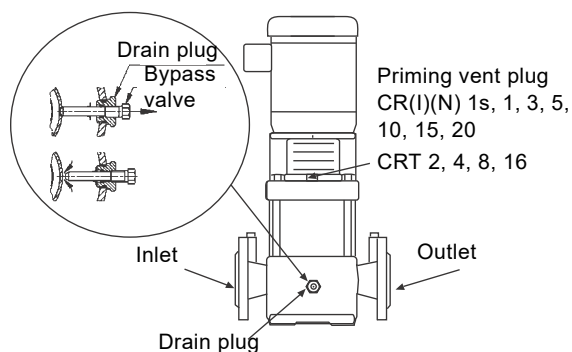

Fig. 13 Position of plugs and bypass valve

TM04 3922 3613

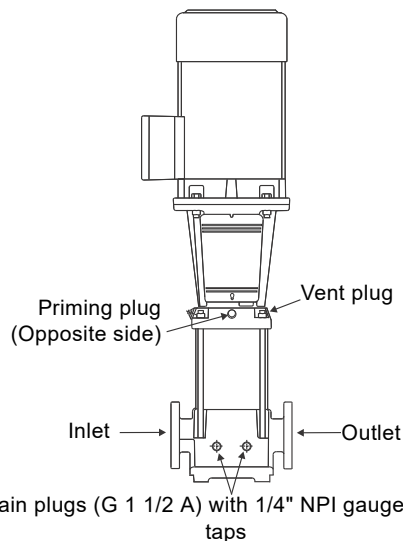

Fig. 14 Position of plugs CR, CRN 32, 45, 64

TM04 4036 3613

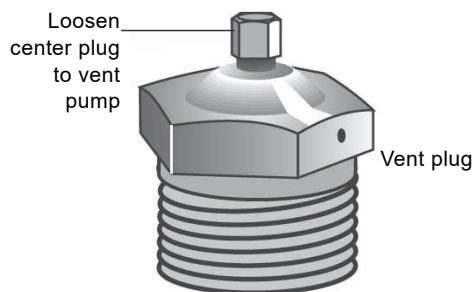

Fig. 15 Vent plug

TM04 3920 3613

In open systems where the water level is below the pump inlet, the inlet pipe and pump must be filled with liquid and vented before starting the pump.

1. Close the outlet isolating valve and remove the priming plug.
2. Pour water through the priming hole until the inlet pipe and pump are completely filled with liquid. If the inlet pipe does not slope downwards away from the pump, the air must be purged while priming the pump.
3. Replace the priming plug and tighten securely.

## 10.2 Startup instructions

1. Gradually open the isolating valve in the inlet line until a steady stream of airless water runs out of the priming hole.
2. Close the plug and tighten securely.
3. Completely open the isolating valves.

For pumps with Cool-Top®, see section [18. Startup of pump with air-cooled top \(Cool-Top®\)](#).

Follow these steps:

1. Switch off the power supply.
2. Check to make sure the pump has been filled and vented.
3. Remove the coupling guard and rotate the pump shaft by hand to make sure it turns freely.
4. Verify that the electrical connections are in accordance with the wiring diagram on the motor.
5. Switch on the power and observe the direction of rotation. When viewed from above, the pump should rotate counter-clockwise (clockwise for CRN-SF).
6. To reverse the direction of rotation, first switch off the power supply.
7. On three-phase motors, interchange any two phases of the power supply.  
On single-phase motors, see wiring diagram on the nameplate. Change wiring as required.
8. Switch on the power again and check for proper direction of rotation. Once direction of rotation has been verified, switch off the power again. Do not attempt to reinstall the coupling guards while the motor is on. Replace the coupling guard if the direction of rotation is correct. When the guards are in place, the power can be switched on again.



Motors should not be run unloaded or uncoupled from the pump at any time; damage to the motor bearings will occur.

Do not start the pump before priming or venting the pump. See fig. 15. Never let the pump run dry.



For CR, CRI, CRN 1s to 5 it is advisable to open the bypass valve during start-up. See fig. 13. The bypass valve connects the inlet and outlet sides of the pump, thus making the filling procedure easier. Close the bypass valve when operation is stable.

## 11. Operating the product

### WARNING

#### Contamination when pumping drinking water

- Death or serious personal injury
- Do not use the pump for drinking water if the internal parts have been in contact with particles or substances not suitable for water intended for human consumption



### WARNING

#### Airborne noise

- Death or serious personal injury
- Wear personal protective equipment.



### WARNING

#### Too high pressure and leakage

- Death or serious personal injury
- Do not run the pump against a closed outlet valve.



### CAUTION

#### Hot or cold surface

- Minor or moderate personal injury
- Make sure that no one can accidentally come into contact with hot or cold surfaces.



### CAUTION

#### Hot or cold liquid

- Minor or moderate personal injury
- Wear personal protective equipment.



### 11.1 Operating parameters

CR multi-stage centrifugal pumps installed in accordance with these instructions and sized for correct performance will operate efficiently and provide years of service. The pumps are water-lubricated and do not require any external lubrication or inspection. The motors may require periodic lubrication as described in section [14. Maintaining the motor](#).

Under no circumstances should the pump be operated for any prolonged periods of time without flow through the pump. This can result in motor and pump damage due to overheating. A properly sized relief valve should be installed to allow sufficient liquid to circulate through the pump to provide adequate cooling and lubrication of the pump bearings and seals.

## 11.2 Pump cycling

Pump cycling should be checked to ensure the pump is not starting more often than the following max. starts per hour:

WEG motors:

- 100 times per hour on 1/3 to 1 HP models
- 20 times per hour on 1 1/2 to 20 HP models
- 10 times per hour on 20 to 150 HP models
- 5 times per hour on 200 to 300 HP models.

Grundfos ML motors:

- 200 times per hour on 1/3 to 5 HP models
- 100 times per hour on 7 1/2 to 15 HP models
- 40 times per hour on 20 to 30 HP models.

Rapid cycling is a major cause of premature motor failure due to overheating of the motor. If necessary, adjust controller to reduce the frequency of starts and stops.

## 11.3 Boiler feed installations

If the pump is used as a boiler feed pump, make sure the pump is capable of supplying sufficient water throughout its entire evaporation and pressure ranges. Where modulating control valves are used, a bypass around the pump must be installed to ensure pump lubrication. See section [7.3 Minimum inlet pressures](#).

## 11.4 Frost protection

If the pump is installed in an area where frost could occur, the pump and system should be drained during freezing temperatures to avoid damage. To drain the pump, close the isolating valves, remove the priming plug and drain plug at the base of the pump. Do not refit the plugs until the pump is to be used again. Always replace the drain plug with the original or an exact replacement. Do not replace with a standard plug. Internal recirculation will occur, reducing the output pressure and flow.

## 12. Servicing the product

### DANGER

#### Electric shock



- Death or serious personal injury
- Before starting any work on the product, make sure that the power supply has been switched off and that it cannot be accidentally switched on.

### WARNING

#### Falling objects



- Death or serious personal injury
- Follow the lifting instructions.
  - Use lifting equipment which is approved for the weight of the product.
  - Persons must keep a safe distance to the product during lifting operations.
  - Wear personal protective equipment.

For lifting instructions, see section [4.3 Lifting instructions](#).

### WARNING

#### Falling objects



- Death or serious personal injury
- Keep the product in a stable and fixed position when working on it.

### WARNING

#### Corrosive liquids



- Death or serious personal injury
- Wear personal protective equipment.

### WARNING

#### Toxic liquids



- Death or serious personal injury
- Wear personal protective equipment.

### WARNING

#### Contamination when pumping drinking water



- Death or serious personal injury
- Before the pump is used for supplying drinking water, flush the pump thoroughly with clean water.
  - Do not use the pump for drinking water if the internal parts have been in contact with particles or substances not suitable for water intended for human consumption.
  - Always use original spare parts suitable for drinking water.

### CAUTION

#### Hot or cold liquid



- Minor or moderate personal injury
- Wear personal protective equipment.



### CAUTION

#### Hot or cold surface



- Minor or moderate personal injury
- Make sure that no one can accidentally come into contact with hot or cold surfaces.



## 12.1 Contaminated products

### CAUTION

#### Biological hazard



- Minor or moderate personal injury
- Flush the product thoroughly with water and rinse the product parts in water after dismantling.

The product will be classified as contaminated if it has been used for a liquid which is injurious to health or toxic.

If you request Grundfos to service the product, contact Grundfos with details about the liquid before returning the product for service. Otherwise, Grundfos can refuse to accept the product for service.

Any application for service must include details about the liquid. Clean the product in the best possible way before you return it. Costs of returning the product are to be paid by the customer.

## 13. Maintaining the pump

### DANGER



#### Electric shock

- Death or serious personal injury
- Before starting any work on the product, make sure that the power supply has been switched off and that it cannot be accidentally switched on.

### WARNING



#### Falling objects

- Death or serious personal injury
- Follow the lifting instructions.
  - Use lifting equipment which is approved for the weight of the product.
  - Persons must keep a safe distance to the product during lifting operations.
  - Wear personal protective equipment.

For lifting instructions, see section [4.3 Lifting instructions](#).

Depending on the conditions and operating time, make the following checks at regular intervals:

- Check that the pump meets the required performance and is operating smoothly and quietly.
- Check that there are no leaks, particularly at the shaft seal.
- Check that the motor is not overheating.
- Remove and clean all strainers or filters in the system.
- Check that the tripping function of the motor overload protection works.
- Check the operation of all controls.
- If the pump is not operated for unusually long periods, maintain the pump in accordance with these instructions. In addition, if the pump is not drained, the pump shaft should be manually rotated or run for short periods of time at monthly intervals.
- In severe-duty applications, pump life may be extended by performing one of the following actions:
  - Drain the pump after each use.
  - Flush the pump with water or other liquid that is compatible with the pump materials and process liquid.
  - Disassemble the pump and thoroughly rinse or wash components in contact with the pumped liquid with water or other liquid that is compatible with the pump materials and process liquid.

If the pump fails to operate or there is a loss of performance, see [section 19. Diagnosing specific problems](#).

## 14. Maintaining the motor

### DANGER



#### Electric shock

- Death or serious personal injury
- Before starting any work on the product, make sure that the power supply has been switched off and that it cannot be accidentally switched on.

### WARNING



#### Falling objects

- Death or serious personal injury
- Follow the lifting instructions.
  - Use lifting equipment which is approved for the weight of the product.
  - Persons must keep a safe distance to the product during lifting operations.
  - Wear personal protective equipment.

For lifting instructions, see section [4.3 Lifting instructions](#).

Only qualified personnel should attempt installation, operation, and maintenance of this equipment.

### 14.1 Motor inspection

Inspect the motor approximately every 500 hours of operation or every three months, whichever occurs first. Keep the motor clean and the ventilation openings clear.

Go through the following steps during each inspection:

1. Check that the motor is clean. Check that the interior and exterior of the motor are free of dirt, oil, grease, water, etc. Oily residue, paper, pulp, textile lint, etc. can accumulate and block motor ventilation. If the motor is not properly ventilated, overheating can occur and cause early motor failure.
2. Use an ohmmeter periodically to ensure that the winding insulation is OK. Record the ohmmeter readings, and immediately investigate any significant drop in insulation resistance.
3. Check all electrical connections to be sure that they are tightened securely.

## 14.2 Motor lubrication

Electric motors are pre-lubricated from factory and do not require additional lubrication at start-up. Motors without external grease zerks have sealed bearings that cannot be re-lubricated. Motors with grease zerks should only be lubricated with approved types of grease. Do not over-grease the bearings. Over-greasing will cause increased bearing heat and can result in bearing or motor failure. Do not mix oil-based grease and silicon grease in motor bearings.

Bearing grease will lose its lubricating ability over time. The lubricating ability of a grease depends primarily on the type of grease, the size of the bearings, the speed at which the bearings operate and the severity of the operating conditions.

Good results can be obtained if the following recommendations are used in your maintenance program. It should also be noted that multistage pumps, pumps running to the left of the performance curve, and certain pump ranges may have higher thrust loads. Pumps with high thrust loads should be greased according to the next service interval level.



Remove the grease outlet plug before adding new grease.

### 14.2.1 Recommended lubricant

Severity of duty	Ambient temperature (max.)	Environment	Approved types of grease
Standard	104 °F (40 °C)	Clean, little corrosion	Grundfos ML motors are greased for life, or the grease type will be stated on the nameplate. WEG motors are greased with Polyrex EM (Exxon Mobile).
Severe	122 °F (50 °C)	Moderate dirt, corrosion	
Extreme	> 122 °F (50 °C) or class H insulation	Severe dirt, abrasive dust, corrosion	

### 14.2.2 Lubricating chart (for motors with grease zerks)

New motors that have been stored for a year or more should be regreased according to the following table:

NEMA (IEC) frame size	Service intervals [hours]			Weight of grease [oz (grams)]	Volume of grease [in <sup>3</sup> (teaspoons)]
	Standard duty	Severe duty	Extreme duty		
Up to and incl. 210 (132)	5500	2750	550	0.30 (8.4)	0.6 (2)
Over 210 up to and incl. 280 (180)	3600	1800	360	0.61 (17.4)	1.2 (3.9)
Over 280 up to and incl. 360 (225)	2200	1100	220	0.81 (23.1)	1.5 (5.2)
Over 360 (225)	2200	1100	220	2.12 (60.0)	4.1 (13.4)

### 14.2.3 Lubricating procedure



Keep grease free from dirt to avoid damage to motor bearings. If the environment is extremely dirty, contact Grundfos, the motor manufacturer, or an authorized service center for additional information.

Do not mix dissimilar types of grease.

- Clean all grease zerks. If the motor does not have grease zerks, the bearing is sealed and cannot be greased externally.
- If the motor is equipped with a grease outlet plug, remove it. This will allow the old grease to be displaced by the new grease. If the motor is stopped, add the recommended amount of grease. If the motor is to be lubricated while running, add a slightly greater quantity of grease.
- Add grease SLOWLY taking approximately one minute until new grease appears at the shaft hole in the flange or grease outlet plug. Never add more than 1 1/2 times the amount of grease shown in the lubricating chart.



If new grease does not appear at the shaft hole or grease outlet, the outlet passage may be blocked. Contact Grundfos service center or certified motor shop.

- Let motors equipped with a grease outlet plug run for 20 minutes before replacing the plug.



## 15. Replacing the motor

### DANGER



#### Electric shock

- Death or serious personal injury
- Before starting any work on the product, make sure that the power supply has been switched off and that it cannot be accidentally switched on.

### WARNING



#### Falling objects

- Death or serious personal injury
- Follow the lifting instructions.
  - Use lifting equipment which is approved for the weight of the product.
  - Persons must keep a safe distance to the product during lifting operations.
  - Wear personal protective equipment.

For lifting instructions, see section [4.3 Lifting instructions](#).



Motors used on CR pumps are specifically selected to our rigid specifications. Replacement motors must be of the same frame size, should be equipped with the same or better bearings and have the same service factor. Failure to follow these recommendations may result in premature motor failure.

If the motor is damaged due to bearing failure, burning or electrical failure, observe the following instructions as to how to remove the motor and how to mount the replacement motor.

### 15.1 Disassembly

Proceed as follows:

1. Disconnect the power supply leads from the motor. Remove the coupling guards.



For CR 1s, 1, 3, 5, 10, 15, and 20: Do not loosen the three hexagon socket head cap screws securing the shaft seal.

2. Use the proper metric hexagon key to loosen the four cap screws in the coupling. Remove coupling halves completely. On CR 1s-CR 20, the shaft pin can be left in the pump shaft. CR, CRN 32, 45 and 64 do not have a shaft pin.
3. Use the correct size spanner to loosen and remove the four mounting bolts joining motor and pump.
4. Lift the motor straight up until the shaft has cleared the motor stool.

### 15.2 Assembly

Proceed as follows:

1. Remove key from motor shaft, if present, and discard.
2. Thoroughly clean the surfaces of the motor and pump mounting flanges. The motor and shaft must be clean of all oil or grease and other contaminants where the coupling attaches. Place the motor on top of the pump.
3. Turn the terminal box to the desired position by rotating the motor.
4. Insert the four mounting bolts, then tighten diagonally and evenly:
  - For 3/8" bolts (1/2 - 2 HP), torque = 17 ft-lb.
  - For 1/2" bolts (3 - 40 HP), torque = 30 ft-lb.
  - For 5/8" bolts (50 - 100 HP), torque = 59 ft-lb.
  - Follow instructions for particular pump model in sections [15.2.2 CR 1s, 1, 3, and 5](#) to [15.2.5 CR, CRN 32, 45 and 64](#).

### 15.2.1 Torque specifications

Torque specifications for CR, CRI, CRN 1s, 1, 3, 5, 10, 15, and 20 CRT 2, 4, 8, and 16

Coupling screw size	Minimum torque
M6	10 ft-lb
M8	23 ft-lb
M10	46 ft-lb

### 15.2.2 CR 1s, 1, 3, and 5

1. Insert shaft pin into shaft hole.
2. Mount the coupling halves onto shaft and shaft pin.
3. Fit the coupling screws and leave loose. Check that the gaps on either side of the coupling are even and that the motor shaft keyway is centered in the coupling half as shown in fig. 16.
4. Tighten the screws to the correct torque. See section [15.2.1 Torque specifications](#).

### 15.2.3 CR 10, 15 and 20

1. Insert shaft pin into shaft hole.
2. Insert plastic shaft seal spacer beneath shaft seal collar.
3. Mount the coupling halves onto shaft and shaft pin.
4. Fit the coupling screws and leave loose. Check that the gaps on either side of the coupling are even and that the motor shaft keyway is centered in the coupling half as shown in fig. 16.
5. Tighten the screws to the correct torque. See section [15.2.1 Torque specifications](#).
6. Remove plastic shaft seal spacer and hang it on inside of coupling guard.

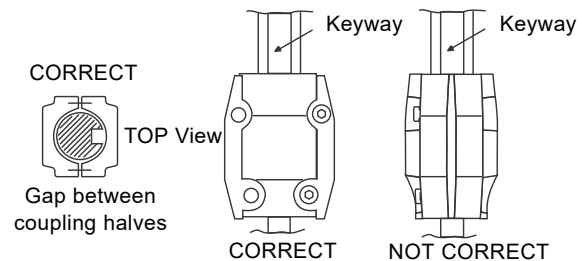
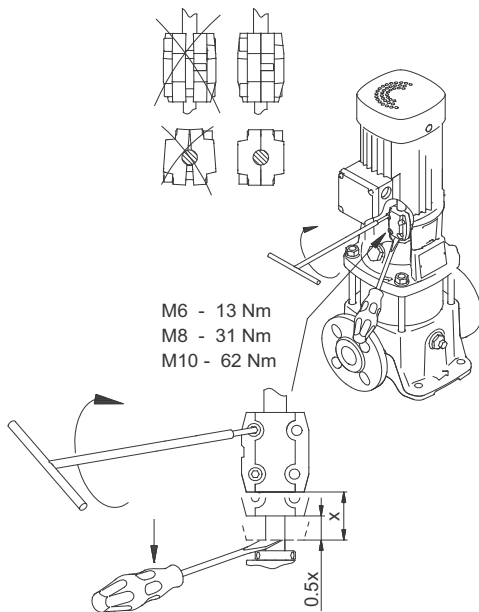

Fig. 16 Coupling adjustment all CR, CRI, CRN, CRT

TM04 3919 3613

**15.2.4 CRT 2, 4, 8 and 16**

1. Mount coupling halves. Make sure the shaft pin is located in the pump shaft.
2. Put the cap screws loosely back into the coupling halves.
3. Using a large screwdriver, raise the pump shaft by placing the tip of the screwdriver under the coupling and carefully raising the coupling to its highest point. See fig. 17.

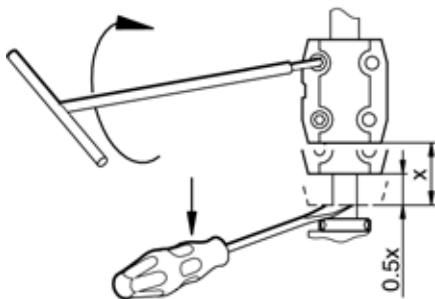

**Fig. 17** Coupling adjustment CRT 2, 4, 8, and 16



The shaft can only be raised approximately 0.20 inches (5 mm).

4. Now lower the shaft halfway back the distance you just raised it and tighten the coupling screws (finger tight) while keeping the coupling gap equal on both sides. When the screws are tight enough to keep the coupling in place, then cross-tighten the screws.
  - Note the clearance below the coupling.
  - Raise the coupling as far as it will go.
  - Lower it halfway back down (1/2 the distance you just raised it).
  - Tighten screws (see torque specifications).



**Fig. 18** Coupling adjustment clearance CRT 2, 4, 8, and 16

TM02 1051 2713

TM02 1051 0501

**15.2.5 CR, CRN 32, 45 and 64**

1. Make sure pump shaft is all the way down. Tighten the set screws on the mechanical shaft seal.
2. Place the plastic adjusting fork under the cartridge seal collar. See fig. 19.

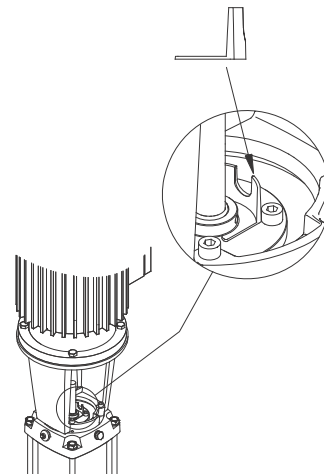

**Fig. 19** Coupling adjustment CR, CRN 32, 45 and 64

3. Fit the coupling on the shaft so that the top of the pump shaft is flush with the bottom of the coupling chamber. See fig. 20.

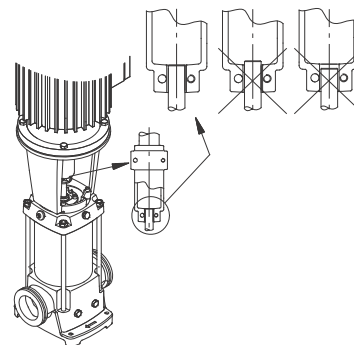

**Fig. 20** Coupling adjustment, CR, CRN 32, 45 and 64



To avoid damaging the coupling halves, ensure that the motor shaft keyway is centered in the coupling half as shown in fig. 16.

4. Lubricate the coupling screws with an anti-seize, lubricating compound. Tighten the coupling screws (finger tight) while keeping the coupling gap equal on both sides and the motor shaft keyway centered in the coupling half as shown in fig. 16. When the screws are tight enough to keep the coupling in place, then cross-tighten the screws.

TM04 3913 0409

TM04 3914 0409

5. Tighten coupling screws to 62 ft-lbs (75 and 100 HP motors to 74 ft-lbs). Remove the adjusting fork from under the cartridge seal collar and replace it to the storage location. See fig. 21.

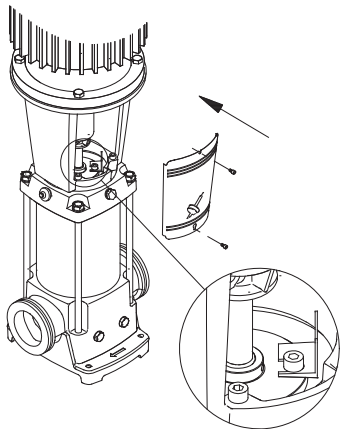

TM04 3915 3613

**Fig. 21** Adjusting fork storage CR, CRN 32, 45 and 64

6. Check to see that the gaps between the coupling halves are equal. Loosen and readjust, if necessary.
7. Make sure the pump shaft can be rotated by hand. If the shaft cannot be rotated or it jams, disassemble and check for misalignment.
8. Prime the pump.
9. Follow the wiring diagram on the motor label for the correct motor wiring combination which matches your supply voltage. Once this has been confirmed, reconnect the power supply leads to the motor.
10. Check the direction of rotation by bump-starting the motor. Direction of rotation must be left to right (counter-clockwise) when looking directly at the coupling.
11. Switch off the power, then mount the coupling guards. When the coupling guards have been mounted, the power can be switched on again.

## 16. Parts list

Grundfos offers an extensive parts list for each CR pump model. A parts list typically covers the following items:

- a diagram of pump parts which we recommend to have on hand for future maintenance
- a list of prepacked service kits covering the pump components most likely to be exposed to wear over time
- complete chamber stacks needed to replace the rotating assembly of each model.

These parts lists are available separately from the Grundfos literature warehouse or as a set with extensive service instructions in the Grundfos CR Service Manuals.



**Fig. 22** Prepacked chamber stack kits

TM05 9272 3613



**Fig. 23** Prepacked flange kits

TM04 3916 1609

### 16.1 Spare parts

Grundfos offers an extensive list of spare parts for CR pumps. For a current list of these parts, see Grundfos All Product Spare Parts/Service Kits Price List, part number L-SK-SL-002.

## 17. Preliminary electrical tests

### DANGER

#### Electric shock



Death or serious personal injury

- Before starting any work on the product, make sure that the power supply has been switched off and that it cannot be accidentally switched on.
- We recommend to wear rubber gloves and boots, and to make sure that metal terminal boxes and motors are grounded before any work is done.

### 17.1 Supply voltage

#### 17.1.1 How to measure the supply voltage

Use a voltmeter (set to the proper scale) to measure the voltage at the pump terminal box or starter. On single-phase units, measure between power leads L1 and L2 (or L1 and N for 115 volt units). On three-phase units, measure between:

- Power leads L1 and L2
- Power leads L2 and L3
- Power leads L3 and L1.

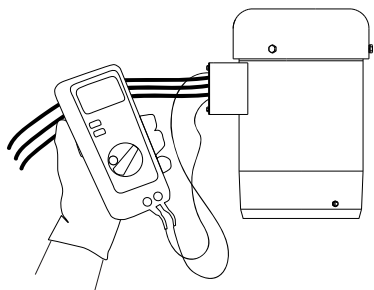

Fig. 24 Measuring supply voltage

TM04 3911 2609

#### 17.1.2 Meaning of supply voltage measurement

When the motor is under load, the voltage should be within + 10 %/- 10 % of the nameplate voltage. Larger voltage variation may cause winding damage. Large variations in the voltage indicate a poor electrical supply and the pump should not be operated until these variations have been corrected. If the voltage constantly remains high or low, the motor should be changed to the correct supply voltage.

## 17.2 Current

#### 17.2.1 How to measure the current

Use an ammeter (set on the proper scale) to measure the current on each power lead at the terminal box or starter. See the motor nameplate for amp draw information. Current should be measured when the pump is operating at constant outlet pressure.

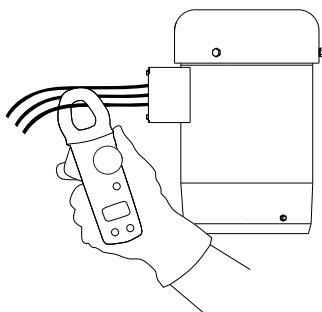

Fig. 25 Measuring current

TM04 3908 2609

#### 17.2.2 Meaning of current measurement

If the amp draw exceeds the listed service factor amps (SFA) or if the current unbalance is greater than 5 % between each leg on three-phase units, check for the following faults:

Fault	Remedy
Burned contacts in the motor-protective circuit breaker.	Replace contacts.
Loose terminals in motor-protective circuit breaker or terminal box or possibly defective lead.	Tighten terminals or replace lead.
Too high or too low supply voltage.	Reestablish correct supply voltage.
Motor windings are short-circuited or grounded. (Check winding and insulation resistances).	Remove cause of short circuit or grounding.
Pump is damaged causing motor overload.	Replace defective pump parts.

### 17.3 Insulation resistance

#### 17.3.1 How to measure the insulation resistance

Turn off power and disconnect the supply power leads in the pump terminal box. Using an ohmmeter or megohmmeter, set the scale selector to R x 100K and zero-adjust the meter. Measure and record the resistance between each of the terminals and ground.

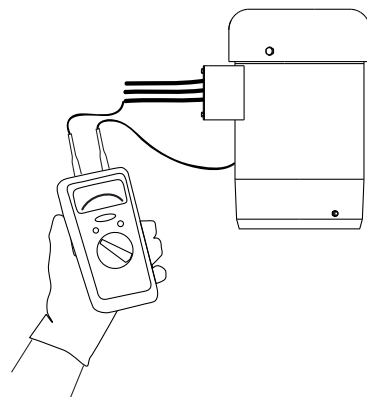

Fig. 26 Measuring insulation resistance

TM04 3907 2609

#### 17.3.2 Meaning of insulation resistance measurement

Motors of all HP, voltage, phase and cycle duties have the same value of insulation resistance. Resistance values for new motors must exceed 1,000,000 ohms. If they do not, the motor should be repaired or replaced.

## 18. Startup of pump with air-cooled top (Cool-Top®)



Do not start the pump until it has been filled with liquid and vented.

### CAUTION



#### Hot or cold liquid

- Minor or moderate personal injury
- Wear personal protective equipment.
  - Pay attention to the direction of the vent hole when you fill the pump with liquid and vent it.
  - Make sure that no persons are hurt by the escaping liquid.

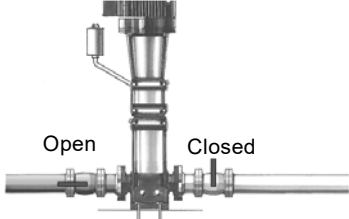
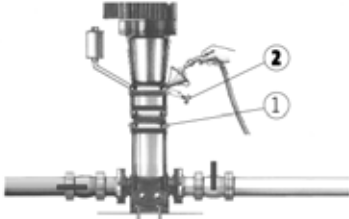
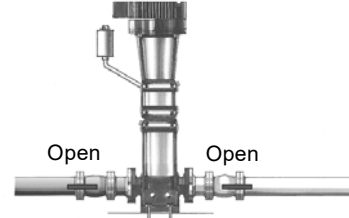
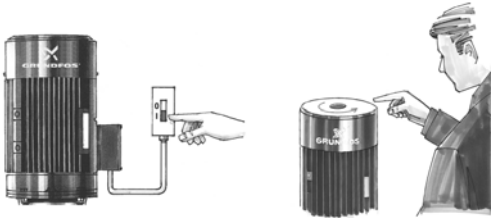

We recommend to connect a drain pipe to the 1/2" air vent in order to lead the hot water or steam to a safe place.

Step	Action
1	 <p>The air-cooled top should only be started up with cold liquid. Close the isolating valve on the outlet side and open the isolating valve on the inlet side of the pump.</p>
2	 <p>Remove the priming plug from the air-cooled chamber (pos. 2) and slowly fill the chamber with liquid.</p> <p>When the chamber is completely filled with liquid, replace the priming plug and tighten securely.</p>
3	 <p>Open the isolating valve on the outlet side of the pump. The valve may have to be partially closed when the pump is started if there is no counter pressure (i.e. boiler not up to pressure).</p>
4	 <p>Start the pump and check the direction of rotation.</p> <p>See the correct direction of rotation of the pump on the motor fan cover.</p> <p>If the direction of rotation is wrong, interchange any two of the incoming power supply leads.</p> <p>After 3 to 5 minutes, the air vent has been filled with liquid.</p>

**Note**

During start-up of a cold pump with hot liquid, it is normal that a few drops of liquid are leaking from the sleeve.

## 19. Diagnosing specific problems

### DANGER



#### Electric shock

Death or serious personal injury

- Before starting any work on the product, make sure that the power supply has been switched off and that it cannot be accidentally switched on.

Problem	Possible cause	Remedy
1. The pump does not run.	a) No power to motor.	Check voltage to motor terminal box. If no voltage to motor, check starter panel for tripped circuits and reset circuits.
	b) Fuses blown or circuit breaker tripped.	Turn off power and remove fuses. Check for continuity with ohmmeter. Replace blown fuses or reset circuit breaker. If new fuses blow or circuit breaker trips, the electrical installation, motor and wires must be checked.
	c) Motor starter overload protection burned or tripped out.	Check for voltage on line and load side of starter. Replace or reset burned motor protection. Inspect starter for other damage. If protection trips again, check the supply voltage and starter holding coil.
	d) Starter does not energize.	Energize control circuit and check for voltage to the holding coil. If no voltage, check control circuit fuses. If voltage, check holding coil for short circuits. Replace bad coil.
	e) Defective control devices.	Check that all safety and pressure switches function correctly. Inspect contacts in control devices. Replace worn or defective parts or control devices.
	f) Motor is defective.	Turn off power and disconnect wiring. Measure the lead-to-lead resistances with ohmmeter (RX-1). Measure lead-to-ground values with ohmmeter (RX-100K). Record measured values. If an open or grounded winding is found, remove motor and repair or replace it.
	g) Defective capacitor (single-phase motors).	Turn off power and outlet capacitor. Check with ohmmeter (RX-100K). When the meter is connected to the capacitor, the needle should jump towards 0 ohms and slowly drift back to infinity (h). Replace capacitor if defective.
	h) Pump is blocked or seized.	Turn off power and manually rotate pump shaft. If shaft does not rotate easily, check coupling setting and adjust as necessary. If shaft rotation is still tight, remove pump and inspect. Disassemble and repair the pump.

Problem	Possible cause	Remedy
2. The pump runs but at reduced performance or does not deliver water.	a) Wrong direction of rotation.	Check wiring for proper connections. Correct wiring.
	b) Pump is not primed or is air-bound.	Turn pump off, close isolation valve(s) and remove priming plug. Check liquid level. Refill the pump, replace plug and start the pump. Long inlet lines must be filled before starting the pump.
	c) Strainers, check or foot valves are clogged.	Remove strainer, screen or check valve and inspect. Clean and replace. Reprime pump.
	d) Suction lift too large.	Install compound pressure gauge at the inlet side of the pump. Start pump and compare reading to performance data. Reduce suction lift by lowering pump, increase inlet line size or removing high friction loss devices.
	e) Inlet and/or outlet pipes leaking. (Pump spins backwards when turned off)	Air in inlet pipe. Inlet pipe, valves and fittings must be airtight. Repair any leaks and retighten all loose fittings.
	f) Pump worn.	Install pressure gauge, start pump, gradually close the outlet valve and read pressure at shutoff. Convert measured pressure (in psi) to head (in feet): (Measured psi x 2.31 ft/psi = ____ ft). Refer to the specific pump curve for shutoff head for that pump model. If head is close to curve, pump is probably OK. If not, remove pump and inspect.
	g) Pump impeller or guide vane is clogged.	Disassemble and inspect pump passageways. Remove any foreign materials found.
	h) Incorrect drain plug installed.	If the proper drain plug is replaced with a standard plug, water will recirculate internally. Replace with proper plug.
	i) Improper coupling setting.	Check/reset the coupling. See page 18.
	3. Pump cycles too much	a) Pressure switch is not properly adjusted or is defective.
b) Level control is not properly adjusted or is defective.		Check that level control is set and functions correctly. Readjust setting (refer to level control manufacturer's data). Replace if defective.
c) Insufficient air charging or leaking tank or piping.		Pump air into tank or diaphragm chamber. Check diaphragm for leaks. Check tank and piping for leaks with soap and water solution. Check air-to-water volume. Repair as necessary.
d) Tank is too small.		Check tank size and air volume in tank. Tank volume should be approximately 10 gallons for each gpm of pump performance. The normal air volume is 2/3 of the total tank volume at the pump cut-in pressure. Replace tank with one of correct size.
e) Pump is oversized.		Install pressure gauges on or near pump inlet and outlet ports. Start and run pump under normal conditions, record gauge readings. Convert psi to feet (Measured psi x 2.31 ft/psi = ____ ft) Refer to the specific pump curve for that model, ensure that total head is sufficient to limit pump delivery within its design flow range. Throttle pump outlet flow if necessary.

Problem	Possible cause	Remedy
4. Fuses blow or circuit breakers or overload relays trip	a) Tank is too small.	Check voltage at starter panel and motor. If voltage varies more than - 10 %/+ 10 %, contact power company. Check wire sizing.
	b) Motor overload protection set too low.	Cycle pump and measure amperage. Increase size of overload protection or adjust trip setting to maximum motor nameplate (full load) current.
	c) Three-phased current is imbalanced.	Check current draw on each lead to the motor. Must be within - 5 %/+ 5 %. If not, check motor and wiring. Rotating all leads may eliminate this problem.
	d) Motor short-circuited or grounded.	Turn off power and disconnect wiring. Measure the lead-to-lead resistance with an ohmmeter (RX-1). Measure lead-to-ground values with an ohmmeter (RX-100K) or a megohmmeter. Record values. If an open or grounded winding is found, remove the motor, repair and/or replace.
	e) Wiring or connections are faulty.	Check proper wiring and loose terminals. Tighten loose terminals. Replace damaged wires.
	f) Pump is blocked or seized.	Turn off power and manually rotate pump shaft. If shaft does not rotate easily, check coupling setting and adjust as necessary. If shaft rotation is still tight, remove pump and inspect. Disassemble and repair the pump.
	g) Defective capacitor (single-phase motors).	Turn off power and outlet capacitor. Check with ohmmeter (RX-100K). When the meter is connected to the capacitor, the needle should jump towards 0 ohms and slowly drift back to infinity ( $\infty$ ). Replace capacitor if defective.
	h) Motor overload protection devices at higher ambient temperature than motor.	Use a thermometer to check the ambient temperature near overload protection devices and motor. Record these values. If ambient temperature at motor is lower than at overload protection devices, especially where temperature at overload protection devices is above 104 °F (40 °C), replace standard protection devices with ambient-compensated protection devices.



## 20. Worksheet for three-phase motors

Below is a worksheet for calculating current unbalance on a three-phase hookup. Use the calculations below as a guide.



Current unbalance should not exceed 5 % at service factor load or 10 % at rated input load. If the unbalance cannot be corrected by rolling the leads, the source of the unbalance must be located and corrected. If, on the three possible hookups, the leg farthest from the average stays on the same power lead, most of the unbalance is coming from the power source. However, if the reading farthest from the averages moves with the same motor lead, the primary source of unbalance is on the "motor side" of the starter. In this instance, consider if the cause can be a damaged cable, an untight cable splice, a poor connection, or a faulty motor winding.

### Explanation and examples

Here is an example of current readings at maximum pump loads on each leg of a three-wire hookup. You must make calculations for all three hookups. To begin, add up all three readings for hookup numbers 1, 2, and 3.

<b>Hookup 1</b>	
T1 =	51 amps
T2 =	46 amps
T3 =	53 amps
TOTAL =	150 amps

Divide the total by three to obtain the average.

<b>Hookup 1</b>	
	50 amps
3	150 amps

Calculate the greatest current difference from the average.

<b>Hookup 1</b>	
	50 amps
-	46 amps
	4 amps

Divide this difference by the average to obtain the percentage of the unbalance. In this case, the current unbalance for **Hookup 1** is 8 %.

<b>Hookup 1</b>	
	.08 or 8 %
50	4.00 amps

### Blank worksheet

<b>Hookup 1</b>	<b>Hookup 2</b>	<b>Hookup 3</b>
L <sub>1</sub> to T <sub>1</sub> = ___ amps	L <sub>1</sub> to T <sub>3</sub> = ___ amps	L <sub>1</sub> to T <sub>2</sub> = ___ amps
L <sub>2</sub> to T <sub>2</sub> = ___ amps	L <sub>2</sub> to T <sub>1</sub> = ___ amps	L <sub>2</sub> to T <sub>3</sub> = ___ amps
L <sub>3</sub> to T <sub>3</sub> = ___ amps	L <sub>3</sub> to T <sub>2</sub> = ___ amps	L <sub>3</sub> to T <sub>1</sub> = ___ amps
TOTAL = ___ amps	TOTAL = ___ amps	TOTAL = ___ amps
<b>Hookup 1</b>	<b>Hookup 2</b>	<b>Hookup 3</b>
___ amps	___ amps	___ amps
3	3	3
___ amps	___ amps	___ amps
<b>Hookup 1</b>	<b>Hookup 2</b>	<b>Hookup 3</b>
___ amps	___ amps	___ amps
___ amps	___ amps	___ amps
___ amps	___ amps	___ amps
<b>Hookup 1</b>	<b>Hookup 2</b>	<b>Hookup 3</b>
___ or ___ %	___ or ___ %	___ or ___ %
___	___	___
___ amps	___ amps	___ amps

## 21. Disposal

This product or parts of it must be disposed of in an environmentally sound way:

1. Use the public or private waste collection service.
2. If this is not possible, contact the nearest Grundfos company or service workshop.



The crossed-out wheelie bin symbol on a product means that it must be disposed of separately from household waste. When a product marked with this symbol reaches its end of life, take it to a collection point designated by the local waste disposal

authorities. The separate collection and recycling of such products will help protect the environment and human health.

See also end-of-life information at [www.grundfos.com/product-recycling](http://www.grundfos.com/product-recycling).



**Grundfos Kansas City**

9300 Loiret Blvd.  
Lenexa, Kansas 66219  
Phone: +1-913-227-3400  
Fax: +1-913-227-3500

[www.grundfos.us](http://www.grundfos.us)

**Grundfos Canada**

2941 Brighton Road  
Oakville, Ontario L6H 6C9 Canada  
Phone: +1-905 829 9533  
Fax: +1-905 829 9512

[www.grundfos.ca](http://www.grundfos.ca)

**Grundfos México**

Boulevard TLC No. 15  
Parque Industrial Stiva Aeropuerto  
C.P. 66600 Apodaca, N.L. Mexico  
Phone: +011-52-81-8144 4000  
Fax: +011-52-81-8144 4010

[www.grundfos.mx](http://www.grundfos.mx)

L-CR-TL-001

<b>98419736</b> 04.2021
-------------------------

ECM: 1311425
--------------

Trademarks displayed in this material, including but not limited to Grundfos, the Grundfos logo and "be think innovate" are registered trademarks owned by The Grundfos Group. All rights reserved. © 2021 Grundfos Holding A/S, all rights reserved.