

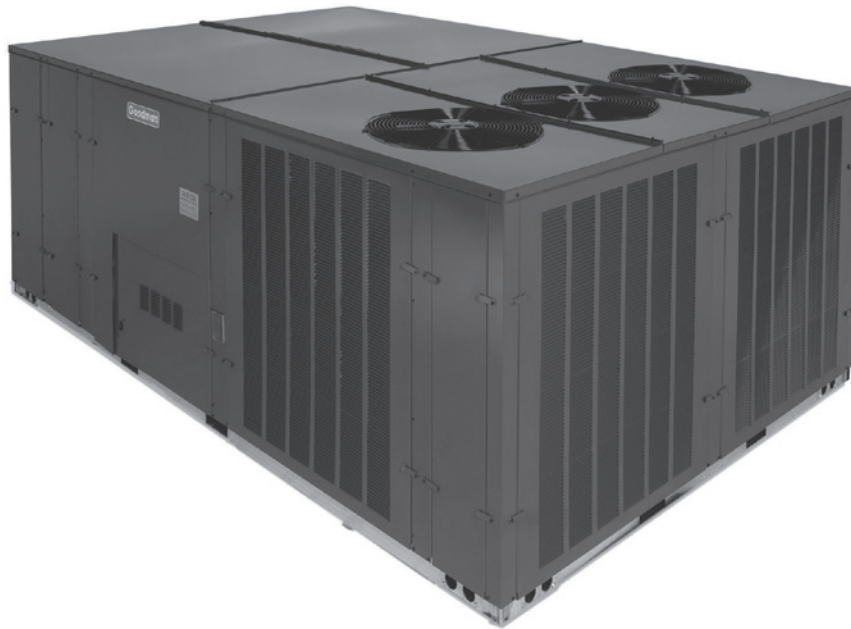

Air Conditioning & Heating



CPG COMMERCIAL 15- & 20-TON, THREE-PHASE PACKAGED GAS/ELECTRIC UNITS

15 TONS

COOLING CAPACITY: 180,000 BTU/H

HEATING CAPACITY: 350,000 BTU/H

20 TONS

COOLING CAPACITY: 240,000 BTU/H

HEATING CAPACITY: 400,000 BTU/H

Standard Features

- R-410A chlorine-free refrigerant
- TuffTube™ tubular heat exchanger
- High-efficiency scroll compressor
- Copper tube / aluminum fin coils
- High- and low-pressure switches
- High-capacity, steel-cased filter dryer
- Built-in filter rack with standard 2" filters (convertible to 4" filters)
- 24-volt terminal strip
- Contactor with lugs
- Easy to service
- Bottom utility entry
- Complies with California NOx emissions standards
- AHRI Certified; ETL Listed

Cabinet Features

- Heavy-gauge, galvanized-steel cabinet with UV-resistant powder-paint finish
- Condenser Hail Guards
- Full Perimeter Rail
- Sloped drain pan

Contents

Nomenclature	2
Product Specifications	3
Expanded Cooling Data	5
Airflow Data	9
Dimensions	11
Wiring Diagrams	15
Accessories	21



* Complete warranty details available from your local dealer or at www.goodmanmfg.com.

NOMENCLATURE

	C	P	G	180	400	3	B	*	*	*	A	*
	1	2	3	4,5,6	7,8,9	10	11	12	13	14	15	16
	Revision Levels Major & Minor											
Brand	Factory-Installed Options											
C Commercial	X No Options A Non-powered convenience outlet B Powered convenience outlet C Low-ambient kit D Return air smoke detector E Supply air smoke detector F Non-powered convenience outlet; Low-ambient kit G Non-powered convenience outlet; Return air smoke detector H Non-powered convenience outlet; Supply air smoke detector J Non-powered convenience outlet; Return & Supply air smoke detectors K Non-powered convenience outlet; Low-ambient kit; Supply air smoke detector L Non-powered convenience outlet; Low-ambient kit Return & Supply air smoke detectors M Powered convenience outlet; Low-ambient kit N Powered convenience outlet; Return air smoke detector O Powered convenience outlet; Return & Supply air smoke detectors P Powered convenience outlet; Supply air smoke detector Q Powered convenience outlet; Low- ambient kit; Return air smoke detector R Powered convenience outlet; Low- ambient kit; Supply air smoke detector T Powered convenience outlet; Low-ambient kit; Return & Supply air smoke detectors U Non-powered convenience outlet; Low-ambient kit; Return air smoke detector V Low-ambient kit; Return air smoke detector W Low-ambient kit; Supply air smoke detector Y Low-ambient kit; Return & Supply air smoke detectors Z Return & Supply air smoke detectors											
Configuration												
P Packaged Unit												
Application												
C Cooling												
G Gas Heat												
H Heat Pump												
Nominal Gross Cooling Capacity												
036 3 Tons 102 8½ Tons												
048 4 Tons 120 10 Tons												
060 5 Tons 150 12½ tons												
072 6 Tons 180 & 181 15 Tons												
090 7½ Tons 240 20 Tons												
Nominal Heating Capacity												
CPG	CPC/CPH (Factory-Installed Electric Heat)											
045 45,000 BTU/h XXX No Heat												
090 90,000 BTU/h 010 10 kW 030 30 kW												
115 115,000 BTU/h 015 15 kW 031 30 kW												
140 140,000 BTU/h 016 15 kW 045 45 kW												
210 210,000 BTU/h 018 18 kW 046 45 kW												
350 350,000 BTU/h 020 20 kW 060 60 kW												
400 400,000 BTU/h 025 25 kW												
See product specifications for heat size(s) available for each capacity.												
Voltage												
1 208-230/1/60 4 460/3/60												
3 208-230/3/60 7 575/3/60												
Supply Fan/Drive Type/Motor												
B Belt Drive												
D Direct Drive												
Factory-Installed Options												
X No Options												
A Downflow Economizer												
H Disconnect Switch (non-fused)												
J Downflow Economizer; Disconnect Switch (non-fused)												
Note: Not all options available for all products.												
Factory-Installed Options	Factory-Installed Options											
<ul style="list-style-type: none"> Stainless-Steel Heat Exchanger (CPG units only): A tubular heat exchanger made of 409-type stainless steel is installed in the unit. Low-Ambient Kit: Allows for cooling operation at lower outdoor temperatures. On the 3- to 6-ton units, cooling operation is extended from 60°F ambient temperature to 35°F outside air temperature. On 7½- to 20-ton units, cooling operation is extended from 35°F ambient temperature to 0°F outside air temperature. Economizers (Downflow): Based on air conditions, can provide outside air to cool the space. Electric Heat Kits (CPC and CPH units only): Available in all voltage options. Non-powered Convenience Outlet: A 120V, 15A, GFCI outlet makes it easier for technicians to service the unit once an electrician runs power to the outlet. Powered Convenience Outlet: A 120V, 15A, GFCI outlet powered with a transformer built into the unit; for use when unit is not running. When a factory-installed convenience outlet is installed in the equipment, the unit MCA will increase by 7.5A for 208/230V units, increase by 3.75A for 460V units, and by 3A for 575V units. The MOP device must be sized accordingly. Disconnect Switch (non-fused): A disconnect switch is installed in the unit and factory wiring will be complete from the switch to the unit. Please note that for air conditioning (CPC units) and heat pump models (CPH units), the appropriate electric heat kit must be ordered to be factory-installed along with the disconnect switch (non-fused) when it is ordered. Please note that for models with a powered convenience outlet option and a disconnect switch (non-fused) option, the power to the powered convenience outlet will be shut off when the disconnect switch (non-fused) is in the off position. Return Air and/or Supply Air Smoke Detectors: Return air and/or supply air smoke detectors are installed in the unit. 	X Standard Aluminized Heat Exchanger S Stainless-Steel Heat Exchanger											

PRODUCT SPECIFICATIONS — 15 TONS

	CPG180 3503B***B*	CPG180 3504B***B*	CPG180 3507B***B*
COOLING CAPACITY			
Total, BTU/h	180,000	180,000	180,000
Sensible BTU/h	127,500	127,500	127,500
EER / IEER	10.8 / 11.0	10.8 / 11.0	10.8 / 11.0
Decibels	88	88	88
AHRI Reference #s	5197871	5197871	5197871
HEATING CAPACITY			
High Input / Output (KBTU/h)	350 / 280	350 / 280	350 / 280
Low Input / Output (KBTU/h)	262.5 / 210	262.5 / 210	262.5 / 210
Steady State Efficiency (%)	80	80	80
Temperature Rise Range (°F) High/Low	30-60 / 20-50	30-60 / 20-50	30-60 / 20-50
No. of Burners	7	7	7
EVAPORATOR MOTOR / COIL			
Motor Type (Belt Drive)	Std Static	Std Static	Std Static
Indoor Nominal CFM	5,400	5,400	5,400
Indoor Motor FLA (Cooling)	12.7	6.4	5.1
Horsepower - RPM	5.0 - 1,725	5.0 - 1,725	5.0 - 1,725
Metering Device	TXV	TXV	TXV
Filter Size (#)	20 x 25 x 2 (6)	20 x 25 x 2 (6)	20 x 25 x 2 (6)
Drain Size (NPT)	1"	1"	1"
R-410A Refrigerant Charge Cir #1	186.2	186.2	186.2
R-410A Refrigerant Charge Cir #2	170.8	170.8	170.8
Evaporator Coil Face Area (ft ²)	20	20	20
Rows Deep / Fins per Inch	4 / 16	4 / 16	4 / 16
BELT DRIVE EVAP FAN DATA			
# of Wheels (D x W)	2 (15" x 12")	2 (15" x 12")	2 (15" x 12")
Motor Sheave	1VP50 x 1½"	1VP50 x 1½"	1VP50 x 1½"
Blower Sheave / Belt	BK90 x 1¾" / BX42	BK90 x 1¾" / BX42	BK90 x 1¾" / BX42
CONDENSER FAN / COIL			
Quantity of Condenser Fan Motors	3	3	3
Horsepower - RPM	½ - 1,075	½ - 1,075	½ - 1,075
Fan Diameter / # Fan Blades	22 / 3	22 / 3	22 / 3
Outdoor Nominal CFM	7,200	7,200	7,200
Face Area (ft ²)	53.3	53.3	53.3
Rows Deep / Fins per Inch	2 / 27	2 / 27	2 / 27
COMPRESSOR			
Quantity / Type	2 / Scroll	2 / Scroll	2 / Scroll
Compressor RLA / LRA CIR. #1	25 / 164	12.2 / 100	9.0 / 78
Compressor RLA / LRA CIR. #2	25 / 164	12.2 / 100	9.0 / 78
ELECTRICAL DATA / STATIC			
Voltage / Phase / Frequency	208-230/3/60	460/3/60	575/3/60
Standard Max Static	1.2	1.2	1.2
Outdoor Fan FLA / LRA	2.4 / 5.2	1.2 / 2.6	.9 / 2.2
Total Unit Amps	69.9	34.4	25.8
Min. Circuit Ampacity ¹	76	38	28
Max. Overcurrent Protection (amps) ²	100	45	35
Entrance Power Supply	2½"	2½"	2½"
Entrance Control Voltage	⅞"	⅞"	⅞"
OPERATING / SHIPPING WEIGHT (LBS)	2083/ 2198	2083/ 2198	2083/ 2198

¹ Wire size should be determined in accordance with National Electrical Codes. Extensive wire runs will require larger wire sizes.

² May use fuses or HACR-type circuit breakers of the same size as noted.

NOTES

- Always check the S&R plate for electrical data on the unit being installed.
- When a factory installed convenience outlet is installed in the equipment the unit MCA will increase by 7.5A for 208/230V units, increase by 3.75A for 460V units and by 3A for 575V units. The MOP device must be sized accordingly.

PRODUCT SPECIFICATIONS — 20 TONS

	CPG240 4003B***B*	CPG240 4004B***B*	CPG240 4007B***B*
COOLING CAPACITY			
Total, BTU/h	240,000	240,000	240,000
Sensible BTU/h	170,000	170,000	170,000
EER / IEER	9.8 / 10.0	9.8 / 10.0	9.8 / 10.0
Decibels	88.3	88.3	88.3
AHRI Reference #s	5327364	5327364	5327364
HEATING CAPACITY			
High Input / Output (KBTU/h)	400 / 320	400 / 320	400 / 320
Low Input / Output (KBTU/h)	300 / 240	300 / 240	300 / 240
Steady State Efficiency (%)	80	80	80
Temperature Rise Range (°F) High/Low	25-55 / 15-45	25-55 / 15-45	25-55 / 15-45
No. of Burners	8	8	8
EVAPORATOR MOTOR / COIL			
Motor Type (Belt Drive)	Std Static Belt Drive	Std Static Belt Drive	Std Static Belt Drive
Indoor Nominal CFM	7,000	7,000	7,000
Indoor Motor FLA (Cooling)	12.7	6.4	5.1
Horsepower - RPM	5.0 - 1,725	5.0 - 1,725	5.0 - 1,725
Metering Device	TXV	TXV	TXV
Filter Size (#)	20 x 25 x 2 (6)	20 x 25 x 2 (6)	20 x 25 x 2 (6)
Drain Size (NPT)	1"	1"	1"
R-410A Refrigerant Charge Cir #s 1 & 2	200 ozs.	200 ozs.	200 ozs.
Evaporator Coil Face Area (ft ²)	20	20	20
Rows Deep / Fins per Inch	4 / 16	4 / 16	4 / 16
BELT DRIVE EVAP FAN DATA			
# of Wheels (D x W)	2 (15" x 15")	2 (15" x 15")	2 (15" x 15")
Motor Sheave	1VP60 x 1½"	1VP60 x 1½"	1VP60 x 1½"
Blower Sheave / Belt	BK100 x 7/16" / BX46	BK100 x 7/16" / BX46	BK100 x 7/16" / BX46
CONDENSER FAN / COIL			
Quantity of Condenser Fan Motors	3	3	3
Horsepower - RPM	½ - 1,075	½ - 1,075	½ - 1,075
Fan Diameter / # Fan Blades	22 / 3	22 / 3	22 / 3
Outdoor Nominal CFM	7,200	7,200	7,200
Face Area (ft ²)	53.3	53.3	53.3
Rows Deep / Fins per Inch	2 / 27	2 / 27	2 / 27
COMPRESSOR			
Quantity / Type	2 / Scroll	2 / Scroll	2 / Scroll
Compressor RLA / LRA ea.	33.3 / 239	17.9 / 125	12.8 / 80
ELECTRICAL DATA / STATIC			
Voltage / Phase / Frequency	208-230/3/60	460/3/60	575/3/60
Standard Max Static	1.4	1.4	1.4
Outdoor Fan FLA / LRA	2.4 / 5.2	1.2 / 2.6	.9 / 2.2
Total Unit Amps	86.5	45.8	33.4
Min. Circuit Ampacity ¹	95	50	37
Max. Overcurrent Protection (amps) ²	125	60	45
Entrance Power Supply	2½"	2½"	2½"
Entrance Control Voltage	7/8"	7/8"	7/8"
OPERATING / SHIPPING WEIGHT (LBS)	2242/ 2357	2242/ 2357	2242/ 2357

¹ Wire size should be determined in accordance with National Electrical Codes. Extensive wire runs will require larger wire sizes.

² May use fuses or HACR-type circuit breakers of the same size as noted.

NOTES

- Always check the S&R plate for electrical data on the unit being installed.
- When a factory installed convenience outlet is installed in the equipment the unit MCA will increase by 7.5A for 208/230V units, increase by 3.75A for 460V units and by 3A for 575V units. The MOP device must be sized accordingly.

EXPANDED COOLING DATA — 15 TONS

IDB		OUTDOOR AMBIENT TEMPERATURE																																																			
		65						75						85						95						105						115																					
		AIRFLOW		59	63	67	71	AIRFLOW		59	63	67	71	AIRFLOW		59	63	67	71	AIRFLOW		59	63	67	71	AIRFLOW		59	63	67	71	AIRFLOW		59	63	67	71																
ENTERING INDOOR WET BULB TEMPERATURE																																																					
70	6075	MBh	176.4	182.8	200.3	-	172.3	178.6	195.6	-	168.2	174.3	191.0	-	164.1	170.1	186.3	-	155.9	161.6	177.0	-	144.4	149.7	164.0	-	176.4	182.8	200.3	-	172.3	178.6	195.6	-	168.2	174.3	191.0	-	164.1	170.1	186.3	-	155.9	161.6	177.0	-	144.4	149.7	164.0	-			
		S/T	0.71	0.59	0.41	-	0.74	0.62	0.43	-	0.76	0.63	0.44	-	0.78	0.65	0.45	-	0.81	0.68	0.47	-	0.82	0.68	0.47	-	0.71	0.59	0.41	-	0.74	0.62	0.43	-	0.76	0.63	0.44	-	0.78	0.65	0.45	-	0.81	0.68	0.47	-	0.82	0.68	0.47	-			
		ΔT	19	16	12	-	19	17	13	-	19	17	13	-	19	17	13	-	19	17	13	-	19	17	13	-	19	16	12	-	19	17	13	-	19	17	13	-	19	17	13	-	18	15	12	-	18	15	12	-			
		HI PR	234	252	266	-	262	282	298	-	298	321	339	-	340	366	386	-	382	411	434	-	422	454	480	-	422	454	480	-	234	252	266	-	262	282	298	-	298	321	339	-	340	366	386	-	382	411	434	-	422	454	480
	LO PR	102	109	119	-	108	115	126	-	112	120	131	-	118	126	137	-	124	132	144	-	128	136	149	-	128	136	149	-	102	109	119	-	108	115	126	-	112	120	131	-	118	126	137	-	124	132	144	-	128	136	149	-
5400	6075	MBh	171.2	177.5	194.5	-	167.3	173.4	189.9	-	163.3	169.2	185.4	-	159.3	165.1	180.9	-	151.3	156.9	171.9	-	140.2	145.3	159.2	-	171.2	177.5	194.5	-	167.3	173.4	189.9	-	163.3	169.2	185.4	-	159.3	165.1	180.9	-	151.3	156.9	171.9	-	140.2	145.3	159.2	-			
		S/T	0.68	0.57	0.39	-	0.70	0.59	0.41	-	0.72	0.60	0.42	-	0.74	0.62	0.43	-	0.77	0.65	0.45	-	0.78	0.65	0.45	-	0.68	0.57	0.39	-	0.70	0.59	0.41	-	0.72	0.60	0.42	-	0.74	0.62	0.43	-	0.77	0.65	0.45	-	0.78	0.65	0.45	-			
		ΔT	20	17	13	-	20	17	13	-	20	17	13	-	20	17	13	-	20	17	13	-	20	17	13	-	20	16	12	-	20	17	13	-	20	17	13	-	20	17	13	-	19	16	12	-	19	16	12	-			
		HI PR	231	249	263	-	260	279	295	-	295	318	336	-	336	362	382	-	378	407	430	-	418	450	475	-	418	450	475	-	231	249	263	-	260	279	295	-	295	318	336	-	336	362	382	-	378	407	430	-	418	450	475
	LO PR	101	108	118	-	107	114	124	-	111	118	129	-	117	124	136	-	122	130	142	-	127	135	147	-	127	135	147	-	101	108	118	-	107	114	124	-	111	118	129	-	117	124	136	-	122	130	142	-	127	135	147	-
4320	6075	MBh	158.1	163.8	179.5	-	154.4	160.0	175.3	-	150.7	156.2	171.1	-	147.0	152.4	167.0	-	139.7	144.8	158.6	-	129.4	134.1	146.9	-	158.1	163.8	179.5	-	154.4	160.0	175.3	-	150.7	156.2	171.1	-	147.0	152.4	167.0	-	139.7	144.8	158.6	-	129.4	134.1	146.9	-			
		S/T	0.65	0.55	0.38	-	0.68	0.57	0.39	-	0.70	0.58	0.40	-	0.72	0.60	0.42	-	0.74	0.62	0.43	-	0.75	0.63	0.43	-	0.65	0.55	0.38	-	0.68	0.57	0.39	-	0.70	0.58	0.40	-	0.72	0.60	0.42	-	0.74	0.62	0.43	-	0.75	0.63	0.43	-			
		ΔT	22	19	14	-	22	19	15	-	22	19	15	-	22	19	15	-	22	19	15	-	22	18	14	-	22	19	14	-	22	19	14	-	22	19	15	-	22	19	15	-	21	18	14	-	21	18	14	-			
		HI PR	224	242	255	-	252	271	286	-	286	308	326	-	326	351	371	-	367	395	417	-	406	436	461	-	406	436	461	-	224	242	255	-	252	271	286	-	286	308	326	-	326	351	371	-	367	395	417	-	406	436	461
	LO PR	98	105	114	-	104	110	121	-	108	115	125	-	113	121	132	-	119	126	138	-	123	131	143	-	123	131	143	-	98	105	114	-	104	110	121	-	108	115	125	-	113	121	132	-	119	126	138	-	123	131	143	-
75	6075	MBh	179.4	184.7	199.9	214.5	175.2	180.4	195.3	209.6	171.0	176.1	190.6	204.6	166.9	171.8	186.0	199.6	158.5	163.2	176.7	189.6	146.8	151.2	163.6	175.6	179.4	184.7	199.9	214.5	175.2	180.4	195.3	209.6	171.0	176.1	190.6	204.6	166.9	171.8	186.0	199.6	158.5	163.2	176.7	189.6	146.8	151.2	163.6	175.6			
		S/T	0.81	0.72	0.55	0.35	0.84	0.75	0.57	0.37	0.86	0.77	0.58	0.37	0.89	0.79	0.60	0.39	0.92	0.82	0.62	0.40	0.93	0.83	0.63	0.40	0.81	0.72	0.55	0.35	0.84	0.75	0.57	0.37	0.86	0.77	0.58	0.37	0.89	0.79	0.60	0.39	0.92	0.82	0.62	0.40	0.93	0.83	0.63	0.40			
		ΔT	22	20	17	11	22	20	17	12	22	20	17	12	22	21	17	12	22	21	17	12	22	21	17	11	22	20	17	11	22	20	17	12	22	21	17	12	22	21	17	12	22	21	17	12	21	19	16	11			
		HI PR	236	254	268	280	265	285	301	314	301	324	342	357	343	369	390	407	386	415	439	458	427	459	485	506	236	254	268	280	265	285	301	314	301	324	342	357	343	369	390	407	386	415	439	458	427	459	485	506			
	LO PR	103	110	120	128	109	116	127	135	114	121	132	140	119	127	138	147	125	133	145	155	129	138	150	160	103	110	120	128	109	116	127	135	114	121	132	140	119	127	138	147	125	133	145	155	129	138	150	160				
5400	6075	MBh	174.2	179.3	194.1	208.3	170.1	175.1	189.6	203.5	166.1	171.0	185.1	198.6	162.0	166.8	180.5	193.8	153.9	158.5	171.5	184.1	142.6	146.8	158.9	170.5	174.2	179.3	194.1	208.3	170.1	175.1	189.6	203.5	166.1	171.0	185.1	198.6	162.0	166.8	180.5	193.8	153.9	158.5	171.5	184.1	142.6	146.8	158.9	170.5			
		S/T	0.77	0.69	0.52	0.34	0.80	0.71	0.54	0.35	0.82	0.73	0.55	0.36	0.85	0.76	0.57	0.37	0.88	0.79	0.59	0.38	0.89	0.79	0.60	0.39	0.77	0.69	0.52	0.34	0.80	0.71	0.54	0.35	0.82	0.73	0.55	0.36	0.85	0.76	0.57	0.37	0.88	0.79	0.59	0.38	0.89	0.79	0.60	0.39			
		ΔT	23	21	17	12	23	21	17	12	23	21	17	12	23	21	17	12	23	21	17	12	23	21	17	12	23	21	17	12	23	21	17	12	23	21	17	12	23	21	17	12	23	21	17	12	21	19	16	11			
		HI PR	234	252	266	277	262	282	298	311	298	321	339	354	340	366	386	403	382	411	434	453	422	454	480	501	234	252	266	277	262	282	298	311	298	321	339	354	340	366	386	403	382	411	434	453	422	454	480	501			
	LO PR	102	109	119	127	108	115	126	134	112	120	131	139	118	126	137	146	124	132	144	153	128	136	149	158	102	109	119	127	108	115	126	134	112	120	131	139	118	126	137	146	124	132	144	153	128	136	149	158				
4320	6075	MBh	160.7	165.5	179.1	192.3	157.0	161.6	175.0	187.8	153.3	157.8	170.8	183.3	149.5	154.0	166.6	178.8	142.0	146.3	158.3	169.9	131.6	135.5	146.6	157.4	160.7	165.5	179.1	192.3	157.0	161.6	175.0	187.8	153.3	157.8	170.8	183.3	149.5	154.0	166.6	178.8	142.0	146.3	158.3	169.9	131.6	135.5	146.6	157.4			
		S/T	0.74	0.67	0.50	0.32	0.77	0.69	0.52	0.34	0.79	0.71	0.53	0.34	0.82	0.73	0.55	0.36	0.85	0.76	0.57	0.37	0.85	0.76	0.57	0.37	0.74	0.67	0.50	0.32	0.77	0.69	0.52	0.34	0.79	0.71	0.53	0.34	0.82	0.73	0.55	0.36	0.85	0.76	0.57	0.37							
		ΔT	25	23	19	13	26	24	19	13	26	24	19	13	26	24	20	14	26	24	19	13	26	24	19	13	25	23	19	13	26	24	19	13	26	24	19	13	26	24	19	13	24	22	18	12							
		HI PR	227	244																																																	

EXPANDED COOLING DATA — 15 TONS (CONT.)

IDB		OUTDOOR AMBIENT TEMPERATURE																																			
		65						75						85						95						105						115					
		ENTERING INDOOR WET BULB TEMPERATURE																																			
AIRFLOW	59	63	67	71	59	63	67	71	59	63	67	71	59	63	67	71	59	63	67	71	59	63	67	71	59	63	67	71									
6075	MBh	182.6	186.5	199.3	213.1	178.3	182.2	194.7	208.1	174.1	177.9	190.0	203.1	169.8	173.5	185.4	198.2	161.3	164.9	176.1	188.3	149.4	152.7	163.2	174.4	182.6	186.5	199.3	213.1								
	S/T	0.89	0.83	0.68	0.51	0.92	0.86	0.70	0.52	0.94	0.88	0.72	0.54	1.00	0.91	0.74	0.56	1.00	0.95	0.77	0.58	1.00	0.95	0.78	0.58	0.89	0.83	0.68	0.51								
	ΔT	25	23	20	16	25	24	21	17	25	24	21	17	26	24	21	17	24	24	21	16	23	22	19	15	25	23	20	16								
	HI PR	238	257	271	283	268	288	304	317	304	328	346	361	347	373	394	411	390	420	443	462	431	464	490	511	238	257	271	283								
80	LO PR	104	111	121	129	110	117	128	136	115	122	133	142	120	128	140	149	126	134	147	156	131	139	152	161	104	111	121	129								
	MBh	177.2	181.1	193.5	206.9	173.1	176.9	189.0	202.0	169.0	172.7	184.5	197.2	164.9	168.5	180.0	192.4	156.6	160.1	171.0	182.8	145.1	148.3	158.4	169.3	177.2	181.1	193.5	206.9								
	S/T	0.85	0.79	0.65	0.48	0.88	0.82	0.67	0.50	0.90	0.84	0.69	0.51	0.93	0.87	0.71	0.53	0.96	0.90	0.74	0.55	0.97	0.91	0.74	0.55	0.85	0.79	0.65	0.48								
	ΔT	26	24	21	17	26	25	22	17	26	25	22	17	26	25	22	17	26	25	21	17	24	23	20	16	26	24	21	17								
4320	HI PR	236	254	268	280	265	285	301	314	301	324	342	357	343	369	390	407	386	415	439	458	427	459	485	506	236	254	268	280								
	LO PR	103	110	120	128	109	116	127	135	114	121	132	140	119	127	139	148	125	133	145	155	129	138	150	160	103	110	120	128								
	MBh	163.6	167.2	178.6	190.9	159.8	163.3	174.4	186.5	156.0	159.4	170.3	182.0	152.2	155.5	166.1	177.6	144.6	147.7	157.8	168.7	133.9	136.8	146.2	156.3	163.6	167.2	178.6	190.9								
	S/T	0.82	0.76	0.62	0.47	0.85	0.79	0.65	0.48	0.87	0.81	0.66	0.49	0.89	0.84	0.68	0.51	0.93	0.87	0.71	0.53	0.94	0.88	0.71	0.53	0.82	0.76	0.62	0.47								
6075	ΔT	28	27	24	19	29	28	24	19	29	28	24	19	29	28	24	19	29	27	24	19	27	26	22	18	28	27	24	19								
	HI PR	229	246	260	271	257	277	292	305	292	315	332	346	333	358	378	395	375	403	426	444	414	445	470	490	229	246	260	271								
	LO PR	100	107	116	124	106	113	123	131	110	117	128	136	116	123	134	143	121	129	141	150	125	133	146	155	100	107	116	124								
	MBh	185.8	189.3	198.3	211.6	181.4	184.9	193.7	206.6	177.1	180.5	189.1	201.7	172.8	176.1	184.5	196.8	164.2	167.3	175.2	187.0	152.1	155.0	162.3	173.2	185.8	189.3	198.3	211.6								
85	S/T	0.93	0.90	0.81	0.66	0.96	0.93	0.84	0.68	0.99	0.95	0.86	0.70	1.00	0.98	0.89	0.72	1.00	1.00	0.92	0.75	1.00	1.00	0.93	0.75	0.93	0.90	0.81	0.66								
	ΔT	26	26	24	21	26	26	25	21	26	26	25	21	26	26	25	21	25	25	24	21	23	23	23	20	26	26	24	21								
	HI PR	241	259	274	285	270	291	307	320	307	331	349	364	350	377	398	415	394	424	448	467	435	468	495	516	241	259	274	285								
	LO PR	105	112	122	130	111	119	129	138	116	123	135	143	122	129	141	150	127	136	148	158	132	140	153	163	105	112	122	130								
5400	MBh	180.3	183.8	192.5	205.4	176.1	179.6	188.1	200.6	172.0	175.3	183.6	195.8	167.8	171.0	179.1	191.1	159.4	162.5	170.1	181.5	147.6	150.5	157.6	168.1	180.3	183.8	192.5	205.4								
	S/T	0.89	0.86	0.77	0.63	0.92	0.89	0.80	0.65	0.94	0.91	0.82	0.67	0.97	0.94	0.85	0.69	1.00	0.97	0.88	0.71	1.00	0.98	0.89	0.72	0.89	0.86	0.77	0.63								
	ΔT	27	27	25	22	28	27	26	22	28	27	26	22	28	27	26	22	27	27	25	22	25	25	24	21	27	27	25	22								
	HI PR	238	257	271	283	268	288	304	317	304	328	346	361	347	373	394	411	390	420	443	462	431	464	490	511	238	257	271	283								
4320	LO PR	104	111	121	129	110	117	128	136	115	122	133	142	120	128	140	149	126	134	147	156	131	139	152	161	104	111	121	129								
	MBh	166.5	169.7	177.7	189.6	162.6	165.7	173.6	185.2	158.7	161.8	169.4	180.8	154.8	157.8	165.3	176.4	147.1	149.9	157.0	167.5	136.3	138.9	145.5	155.2	166.5	169.7	177.7	189.6								
	S/T	0.86	0.83	0.74	0.60	0.89	0.86	0.77	0.63	0.91	0.88	0.79	0.64	0.94	0.91	0.82	0.66	0.97	0.94	0.85	0.69	0.98	0.95	0.85	0.69	0.86	0.83	0.74	0.60								
	ΔT	30	30	28	24	31	30	29	25	31	30	29	25	31	30	29	25	30	30	28	25	28	28	26	23	30	30	28	24								
6075	HI PR	231	249	263	274	260	279	295	308	295	318	335	350	336	362	382	399	378	407	430	448	418	450	475	495	231	249	263	274								
	LO PR	101	108	118	125	107	114	124	132	111	118	129	138	117	124	136	145	122	130	142	151	127	135	147	157	101	108	118	125								
	MBh	180.3	183.8	192.5	205.4	176.1	179.6	188.1	200.6	172.0	175.3	183.6	195.8	167.8	171.0	179.1	191.1	159.4	162.5	170.1	181.5	147.6	150.5	157.6	168.1	180.3	183.8	192.5	205.4								
	S/T	0.89	0.86	0.77	0.63	0.92	0.89	0.80	0.65	0.94	0.91	0.82	0.67	0.97	0.94	0.85	0.69	1.00	0.97	0.88	0.71	1.00	0.98	0.89	0.72	0.89	0.86	0.77	0.63								
85	ΔT	27	27	25	22	28	27	26	22	28	27	26	22	28	27	26	22	27	27	25	22	25	25	24	21	27	27	25	22								
	HI PR	238	257	271	283	268	288	304	317	304	328	346	361	347	373	394	411	390	420	443	462	431	464	490	511	238	257	271	283								
	LO PR	104	111	121	129	110	117	128	136	115	122	133	142	120	128	140	149	126	134	147	156	131	139	152	161	104	111	121	129								
	MBh	166.5	169.7	177.7	189.6	162.6	165.7	173.6	185.2	158.7	161.8	169.4	180.8	154.8	157.8	165.3	176.4	147.1	149.9	157.0	167.5	136.3	138.9	145.5	155.2	166.5	169.7	177.7	189.6								
6075	S/T	0.86	0.83	0.74	0.60	0.89	0.86	0.77	0.63	0.91	0.88	0.79	0.64	0.94	0.91	0.82	0.66	0.97	0.94	0.85	0.69	0.98	0.95	0.85	0.69	0.86	0.83	0.74	0.60								
	ΔT	30	30	28	24	31	30	29	25	31	30	29	25	31	30	29	25	30	30	28	25	28	28	26	23	30	30	28	24								
	HI PR	231	249	263	274	260	279	295	308	295	318	335	350	336	362	382	399	378	407	430	448	418	450	475	495	231	249	263	274								
	LO PR	101	108	118	125	107	114	124	132	111	118	129	138	117	124	136	145	122	130	142	151	127	135	147	157	101	108	118	125								

IDB: Entering Indoor Dry Bulb Temperature
 Shaded area reflects AHRI (TVA) conditions
 High and low pressures are measured at the liquid and suction access fittings.

EXPANDED COOLING DATA — 20 TONS

IDB		OUTDOOR AMBIENT TEMPERATURE																																					
		65						75						85						95						105						115							
		AIRFLOW				ENTERING INDOOR WET BULB TEMPERATURE				AIRFLOW				ENTERING INDOOR WET BULB TEMPERATURE				AIRFLOW				ENTERING INDOOR WET BULB TEMPERATURE				AIRFLOW				ENTERING INDOOR WET BULB TEMPERATURE				AIRFLOW				ENTERING INDOOR WET BULB TEMPERATURE	
70	7875	MBh	235.2	243.8	267.1	-	229.7	238.1	260.9	-	224.2	232.4	254.6	-	218.8	226.8	248.4	-	207.8	215.4	236.0	-	192.5	199.5	218.6	-													
		S/T	0.71	0.59	0.41	-	0.74	0.62	0.43	-	0.76	0.63	0.44	-	0.78	0.65	0.45	-	0.81	0.68	0.47	-	0.82	0.68	0.47	-													
		ΔT	20	17	13	-	20	17	13	-	20	17	13	-	20	17	13	-	20	17	13	-	18	16	12	-													
		HI PR	268	289	305	-	301	324	342	-	343	369	389	-	390	420	443	-	439	472	499	-	485	522	551	-													
		LO PR	99	105	115	-	105	111	121	-	109	116	126	-	114	121	133	-	120	127	139	-	124	132	144	-													
		MBh	228.3	236.7	259.3	-	223.0	231.2	253.3	-	217.7	225.7	247.2	-	212.4	220.1	241.2	-	201.8	209.1	229.1	-	186.9	193.7	212.3	-													
	S/T	0.68	0.57	0.39	-	0.70	0.59	0.41	-	0.72	0.60	0.42	-	0.74	0.62	0.43	-	0.77	0.65	0.45	-	0.78	0.65	0.45	-														
	ΔT	20	18	13	-	21	18	14	-	21	18	14	-	21	18	14	-	20	18	13	-	19	17	13	-														
	HI PR	266	286	302	-	298	321	339	-	339	365	385	-	386	416	439	-	435	468	494	-	480	517	546	-														
	LO PR	98	104	114	-	104	110	120	-	108	115	125	-	113	120	131	-	118	126	138	-	123	130	142	-														
	5600	MBh	210.7	218.4	239.3	-	205.8	213.4	233.8	-	200.9	208.3	228.2	-	196.0	203.2	222.6	-	186.2	193.0	211.5	-	172.5	178.8	195.9	-													
		S/T	0.65	0.55	0.38	-	0.68	0.57	0.39	-	0.70	0.58	0.40	-	0.72	0.60	0.42	-	0.74	0.62	0.43	-	0.75	0.63	0.43	-													
ΔT		23	20	15	-	23	20	15	-	23	20	15	-	23	20	15	-	23	20	15	-	21	18	14	-														
HI PR		258	277	293	-	289	311	329	-	329	354	374	-	375	403	426	-	422	454	479	-	466	501	529	-														
LO PR		95	101	110	-	100	107	117	-	104	111	121	-	110	117	127	-	115	122	133	-	119	126	138	-														
MBh		239.2	246.2	266.5	286.1	233.6	240.5	260.3	279.4	228.0	234.8	254.1	272.8	222.5	229.1	247.9	266.1	211.4	217.6	235.5	252.8	195.8	201.6	218.2	234.2														
75	7875	S/T	0.81	0.72	0.55	0.35	0.84	0.75	0.57	0.37	0.86	0.77	0.58	0.37	0.89	0.79	0.60	0.39	0.92	0.82	0.62	0.40	0.93	0.83	0.63	0.40													
		ΔT	23	21	17	12	23	21	17	12	23	21	17	12	23	21	17	12	23	21	17	12	21	20	16	11													
		HI PR	271	292	308	321	304	327	346	361	346	372	393	410	394	424	448	467	443	477	504	526	490	527	557	581													
		LO PR	100	106	116	124	106	112	123	131	110	117	128	136	115	123	134	143	121	129	140	150	125	133	145	155													
		MBh	232.2	239.1	258.8	277.7	226.8	233.5	252.8	271.3	221.4	228.0	246.7	264.8	216.0	222.4	240.7	258.4	205.2	211.3	228.7	245.4	190.1	195.7	211.8	227.4													
		S/T	0.77	0.69	0.52	0.34	0.80	0.71	0.54	0.35	0.82	0.73	0.55	0.36	0.85	0.76	0.57	0.37	0.88	0.79	0.59	0.38	0.89	0.79	0.60	0.39													
	5600	ΔT	24	22	18	12	24	22	18	12	24	22	18	12	24	22	18	13	24	22	18	12	22	20	17	12													
		HI PR	269	289	305	318	301	324	342	357	343	369	389	406	390	420	444	463	439	473	499	520	485	522	551	575													
		LO PR	99	105	115	122	105	111	122	129	109	116	126	135	114	122	133	141	120	127	139	148	124	132	144	153													
		MBh	214.3	220.7	238.8	256.3	209.3	215.5	233.3	250.4	204.4	210.4	227.7	244.4	199.4	205.3	222.2	238.5	189.4	195.0	211.1	226.5	175.4	180.6	195.5	209.8													
		S/T	0.74	0.67	0.50	0.32	0.77	0.69	0.52	0.34	0.79	0.71	0.53	0.34	0.82	0.73	0.55	0.36	0.85	0.76	0.57	0.37	0.85	0.76	0.58	0.37													
		ΔT	26	24	20	14	26	24	20	14	27	24	20	14	27	25	20	14	26	24	20	14	25	23	19	13													
HI PR	260	280	296	309	292	315	332	346	332	358	378	394	379	407	430	449	426	458	484	505	471	506	535	558															
LO PR	96	102	112	119	101	108	118	126	105	112	123	130	111	118	129	137	116	124	135	144	120	128	139	149															

IDB: Entering Indoor Dry Bulb Temperature
 Shaded area reflects ACCA (TVA) conditions
 High and low pressures are measured at the liquid and suction access fittings.

EXPANDED COOLING DATA — 20 TONS (CONT.)

IDB		OUTDOOR AMBIENT TEMPERATURE																																																																															
		65						75						85						95						105						115																																																	
		AIRFLOW				ENTERING INDOOR WET BULB TEMPERATURE		AIRFLOW				ENTERING INDOOR WET BULB TEMPERATURE		AIRFLOW				ENTERING INDOOR WET BULB TEMPERATURE		AIRFLOW				ENTERING INDOOR WET BULB TEMPERATURE		AIRFLOW				ENTERING INDOOR WET BULB TEMPERATURE																																																			
80	7875	MBh	243.4	248.7	265.7	284.1	237.8	242.9	259.6	277.5	232.1	237.2	253.4	270.9	226.4	231.4	247.2	264.3	215.1	219.8	234.8	251.0	199.3	203.6	217.5	232.5	S/T	0.89	0.83	0.68	0.51	0.92	0.86	0.70	0.52	0.94	0.88	0.72	0.54	1.00	0.91	0.74	0.56	1.00	0.95	0.77	0.58	1.00	0.95	0.78	0.58																														
		ΔT	25	24	21	17	26	24	21	17	17	26	24	21	17	26	25	21	17	25	24	21	17	23	23	20	16	HI PR	274	295	311	325	307	331	349	364	350	376	397	414	398	428	452	472	448	482	509	531	495	533	562	587																													
		LO PR	101	107	117	125	107	114	124	132	132	111	118	129	137	117	124	135	144	122	130	142	151	126	134	147	156	MBh	236.3	241.5	258.0	275.8	230.8	235.9	252.0	269.4	225.3	230.3	246.0	263.0	219.8	224.6	240.0	256.6	208.8	213.4	228.0	243.7	193.5	197.7	211.2	225.8	S/T	0.85	0.79	0.65	0.48	0.88	0.82	0.67	0.50	0.93	0.87	0.71	0.53	0.96	0.90	0.74	0.55	0.97	0.91	0.74	0.55	0.97	0.91	0.74	0.55				
		ΔT	26	25	22	17	27	25	22	18	18	27	25	22	18	27	26	22	18	26	25	22	18	25	24	21	16	HI PR	271	292	308	321	304	328	346	361	346	372	393	410	394	424	448	467	444	477	504	526	490	527	557	581																													
		LO PR	100	106	116	124	106	112	123	131	131	110	117	128	136	115	123	134	143	121	129	140	150	125	133	145	155	MBh	218.1	222.9	238.1	254.6	213.1	217.7	232.6	248.6	208.0	212.5	227.1	242.7	202.9	207.3	221.5	236.8	192.8	197.0	210.4	225.0	178.6	182.5	194.9	208.4	S/T	0.82	0.76	0.62	0.47	0.85	0.79	0.65	0.48	0.87	0.81	0.66	0.49	0.89	0.84	0.68	0.51	0.93	0.87	0.71	0.53	0.94	0.88	0.71	0.53	0.94	0.88	0.71	0.53
		ΔT	29	28	24	19	30	28	25	20	20	30	28	25	20	30	29	25	20	29	28	24	20	27	26	23	18	HI PR	263	283	299	312	295	318	335	350	336	361	382	398	382	412	435	453	430	463	489	510	475	512	540	563																													
	LO PR	97	103	113	120	103	109	119	127	127	107	113	124	132	112	119	130	138	117	125	136	145	121	129	141	150	MBh	247.7	252.5	264.4	282.1	241.9	246.6	258.3	275.5	236.2	240.7	252.1	269.0	230.4	234.8	246.0	262.4	218.9	223.1	233.7	249.3	202.7	206.7	216.4	230.9	S/T	0.93	0.90	0.81	0.66	0.96	0.93	0.84	0.68	0.99	0.95	0.86	0.70	1.00	0.98	0.89	0.72	1.00	1.00	0.92	0.75	1.00	1.00	0.93	0.75					
	85	7875	ΔT	27	26	25	22	27	27	25	22	27	27	25	22	27	27	26	22	27	28	26	23	26	26	23	20	HI PR	277	298	314	328	310	334	353	368	353	380	401	419	402	433	457	477	452	487	514	536	500	538	568	592																													
			LO PR	102	109	119	126	108	115	125	133	133	112	119	130	139	118	125	137	146	123	131	143	153	128	136	148	158	MBh	240.5	245.1	256.7	273.9	234.9	239.4	250.7	267.5	229.3	233.7	244.8	261.1	223.7	228.0	238.8	254.8	212.5	216.6	226.9	242.0	196.8	200.6	210.1	224.2	S/T	0.89	0.86	0.77	0.63	0.92	0.89	0.80	0.65	0.94	0.91	0.82	0.67	0.97	0.94	0.85	0.69	1.00	0.97	0.88	0.71	1.00	0.98	0.89	0.72			
			ΔT	28	28	26	23	28	28	26	23	23	28	28	26	23	29	28	27	23	28	28	26	23	26	26	24	21	HI PR	274	295	311	325	307	331	349	364	350	376	397	414	398	428	452	472	448	482	509	531	495	533	562	587																												
			LO PR	101	107	117	125	107	114	124	132	132	111	118	129	137	117	124	135	144	122	130	142	151	126	134	147	156	MBh	221.9	226.2	236.9	252.8	216.8	221.0	231.4	246.9	211.6	215.7	225.9	241.0	206.5	210.5	220.4	235.1	196.1	199.9	209.4	223.4	181.7	185.2	194.0	206.9	S/T	0.86	0.83	0.74	0.60	0.89	0.86	0.77	0.63	0.91	0.88	0.79	0.64	0.94	0.91	0.82	0.66	0.97	0.94	0.85	0.69	0.98	0.95	0.85	0.69			
			ΔT	31	31	29	25	32	31	29	25	25	32	31	29	25	32	31	30	26	31	31	29	25	29	29	27	24	HI PR	266	286	302	315	298	321	339	353	339	365	385	402	386	416	439	458	435	468	494	515	480	517	546	569																												
LO PR			98	104	114	121	104	110	120	128	128	108	114	125	133	113	120	131	140	118	126	138	147	123	130	142	152	MBh	247.7	252.5	264.4	282.1	241.9	246.6	258.3	275.5	236.2	240.7	252.1	269.0	230.4	234.8	246.0	262.4	218.9	223.1	233.7	249.3	202.7	206.7	216.4	230.9	S/T	0.93	0.90	0.81	0.66	0.96	0.93	0.84	0.68	0.99	0.95	0.86	0.70	1.00	0.98	0.89	0.72	1.00	1.00	0.92	0.75	1.00	1.00	0.93	0.75				
5600		ΔT	29	28	24	19	30	28	25	20	20	30	28	25	20	30	29	25	20	29	28	24	20	27	26	23	18	HI PR	263	283	299	312	295	318	335	350	336	361	382	398	382	412	435	453	430	463	489	510	475	512	540	563																													
		LO PR	97	103	113	120	103	109	119	127	127	107	113	124	132	112	119	130	138	117	125	136	145	121	129	141	150	MBh	247.7	252.5	264.4	282.1	241.9	246.6	258.3	275.5	236.2	240.7	252.1	269.0	230.4	234.8	246.0	262.4	218.9	223.1	233.7	249.3	202.7	206.7	216.4	230.9	S/T	0.93	0.90	0.81	0.66	0.96	0.93	0.84	0.68	0.99	0.95	0.86	0.70	1.00	0.98	0.89	0.72	1.00	1.00	0.92	0.75	1.00	1.00	0.93	0.75				
		ΔT	29	28	24	19	30	28	25	20	20	30	28	25	20	30	29	25	20	29	28	24	20	27	26	23	18	HI PR	263	283	299	312	295	318	335	350	336	361	382	398	382	412	435	453	430	463	489	510	475	512	540	563																													
		LO PR	97	103	113	120	103	109	119	127	127	107	113	124	132	112	119	130	138	117	125	136	145	121	129	141	150	MBh	247.7	252.5	264.4	282.1	241.9	246.6	258.3	275.5	236.2	240.7	252.1	269.0	230.4	234.8	246.0	262.4	218.9	223.1	233.7	249.3	202.7	206.7	216.4	230.9	S/T	0.93	0.90	0.81	0.66	0.96	0.93	0.84	0.68	0.99	0.95	0.86	0.70	1.00	0.98	0.89	0.72	1.00	1.00	0.92	0.75	1.00	1.00	0.93	0.75				
		ΔT	29	28	24	19	30	28	25	20	20	30	28	25	20	30	29	25	20	29	28	24	20	27	26	23	18	HI PR	263	283	299	312	295	318	335	350	336	361	382	398	382	412	435	453	430	463	489	510	475	512	540	563																													
		LO PR	97	103	113	120	103	109	119	127	127	107	113	124	132	112	119	130	138	117	125	136	145	121	129	141	150	MBh	247.7	252.5	264.4	282.1	241.9	246.6	258.3	275.5	236.2	240.7	252.1	269.0	230.4	234.8	246.0	262.4	218.9	223.1	233.7	249.3	202.7	206.7	216.4	230.9	S/T	0.93	0.90	0.81	0.66	0.96	0.93	0.84	0.68	0.99	0.95	0.86	0.70	1.00	0.98	0.89	0.72	1.00	1.00	0.92	0.75	1.00	1.00	0.93	0.75				

IDB: Entering Indoor Dry Bulb Temperature
 Shaded area reflects AHRI (TVA) conditions
 High and low pressures are measured at the liquid and suction access fittings.

AIRFLOW DATA — 15 TONS

Standard Belt Drive

ESP In" H ₂ O	Turns Open													
	0		1		2		3		4		5		6	
	CFM	BHP	CFM	BHP	CFM	BHP	CFM	BHP	CFM	BHP	CFM	BHP	CFM	BHP
0.2	---	---	---	---	---	---	0	6,827	2.6675	6,394	2.2792	5,982	1.9434	
0.4	---	---	---	---	7,079	3.2019	6,623	2.7551	6,161	2.3441	5,706	1.9787	5,271	1.6650
0.6	---	---	6,903	3.3168	6,405	2.8302	5,923	2.4063	5,434	2.0191	4,949	1.6776	---	---
0.8	6,717	3.4193	6,198	2.9169	5,668	2.4546	5,152	2.0544	---	---	---	---	---	---
1.0	5,975	2.9894	5,418	2.5110	---	---	---	---	---	---	---	---	---	---
1.2	5,147	2.5507	---	---	---	---	---	---	---	---	---	---	---	---

High-Static Belt Drive

ESP In" H ₂ O	Turns Open													
	0		1		2		3		4		5		6	
	CFM	BHP	CFM	BHP	CFM	BHP	CFM	BHP	CFM	BHP	CFM	BHP	CFM	BHP
1.0	---	---	---	---	---	---	---	6,690	3.6895	6,008	3.0189	5,321	2.4323	
1.2	---	---	---	---	---	---	6,653	3.9517	5,922	3.2198	5,182	2.5787	---	---
1.4	---	---	---	---	6,634	2.8014	5,857	3.4408	5,056	2.7377	---	---	---	---
1.6	---	---	6,638	4.5544	5,808	2.4260	4,948	2.9127	---	---	---	---	---	---
1.8	6,683	4.9263	5,784	3.9520	4,855	2.0548	---	---	---	---	---	---	---	---
2.0	5,803	4.2723	4,788	3.3189	---	---	---	---	---	---	---	---	---	---

NOTES

- Airflow table represent dry coil with filters installed; SCFM correction factor for wet coil is 4%.
- Any adjustment made to the blower should not cause the motor to draw more than the motor rated RLA. Application that exceed the above could require a larger motor. Minimum rated SCFM is 350 per ton.
- High-static airflow requires installation of high kit (HSKT240) or factory-built high-static model.
- Unit factory shipped with the sheave set at 2.5 turns open.

AIRFLOW DATA — 20 TONS

Standard Belt Drive — Down Shot

ESP In" H ₂ O	Turns Open													
	0		1		2		3		4		5		6	
	CFM	BHP	CFM	BHP	CFM	BHP	CFM	BHP	CFM	BHP	CFM	BHP	CFM	BHP
0.2	---	---	---	---	9,359	4.9235	8,991	3.7928	8,621	3.5442	8,188	3.2694	7,826	3.0421
0.4	---	---	9,018	3.1834	8,632	4.3858	8,251	3.3897	7,867	3.1452	7,363	2.8481	6,992	2.6282
0.6	---	---	8,279	2.9618	7,879	3.8623	7,484	2.9949	7,085	2.7548	---	---	---	---
0.8	7,957	4.8180	7,513	2.7320	7,097	3.3548	---	---	---	---	---	---	---	---
1.0	7,179	4.2309	6,716	2.4930	---	---	---	---	---	---	---	---	---	---
1.2	6,368	3.6582	---	---	---	---	---	---	---	---	---	---	---	---

High-Static Belt Drive — Down Shot

ESP In" H ₂ O	Turns Open													
	0		1		2		3		4		5		6	
	CFM	BHP	CFM	BHP	CFM	BHP	CFM	BHP	CFM	BHP	CFM	BHP	CFM	BHP
1.0	---	---	---	---	---	---	9,001	6.8290	8,394	6.0087	7,797	4.7808	7,227	4.2762
1.2	---	---	---	---	8,891	6.8284	8,262	6.1503	7,632	5.3530	7,012	4.1965	---	---
1.4	---	---	8,811	6.8641	8,148	6.1510	7,495	5.4811	6,841	4.7084	---	---	---	---
1.6	---	---	8,065	6.1877	7,377	5.4834	---	---	---	---	---	---	---	---
1.8	7,998	6.8862	7,290	5.5213	---	---	---	---	---	---	---	---	---	---
2.0	7,221	6.1024	---	---	---	---	---	---	---	---	---	---	---	---

NOTES

- Airflow table represent dry coil with filters installed; SCFM correction factor for wet coil is 4%.
- Any adjustment made to the blower should not cause the motor to draw more than the motor rated RLA. Application that exceed the above could require a larger motor. Minimum rated SCFM is 350 per ton.
- High-static airflow requires installation of high kit (HSKT240) or factory-built high-static model.
- Unit factory shipped with the sheave set at 2.5 turns open.

DIMENSIONS

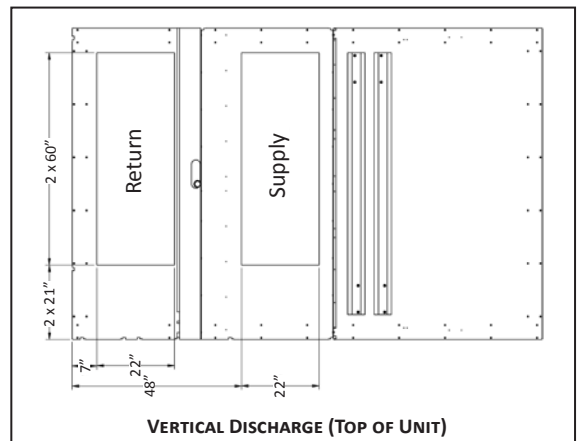
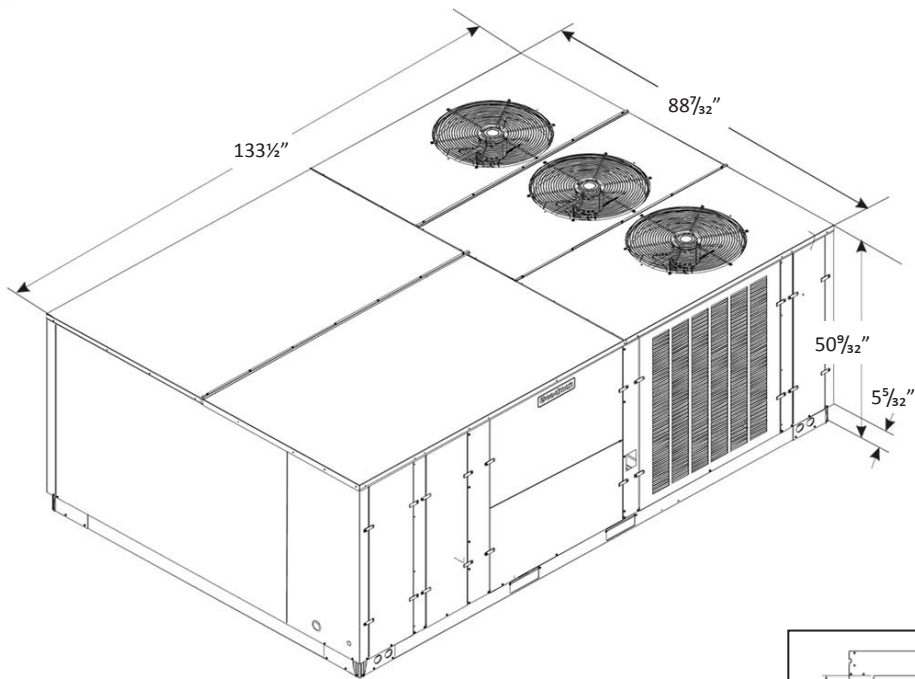

GAS INLET LOCATION (3/4" NPT)

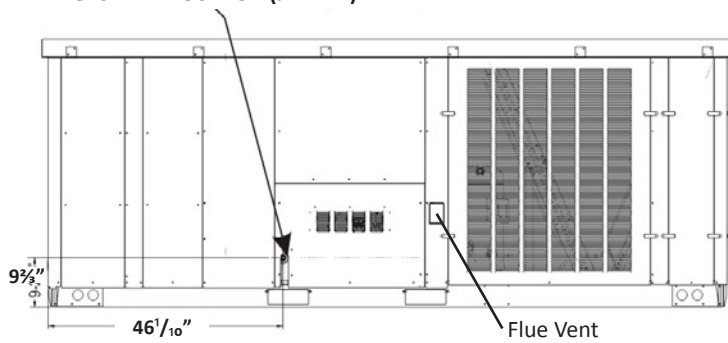

UNIT CLEARANCES

Maintain an adequate clearance around the unit for safety, service, maintenance, and proper unit operation. Leave a total clearance of 75" on the main control panel side of the unit for possible removal of fan shaft, coil, electric heat, and gas furnace. Leave a clearance of 48" on all other sides of the unit for possible compressor removal or service access, and to ensure proper ventilation and condenser airflow. Do not install the unit beneath any obstruction. Install the unit away from all building exhausts to inhibit ingestion of exhaust air into the unit's fresh-air intake.

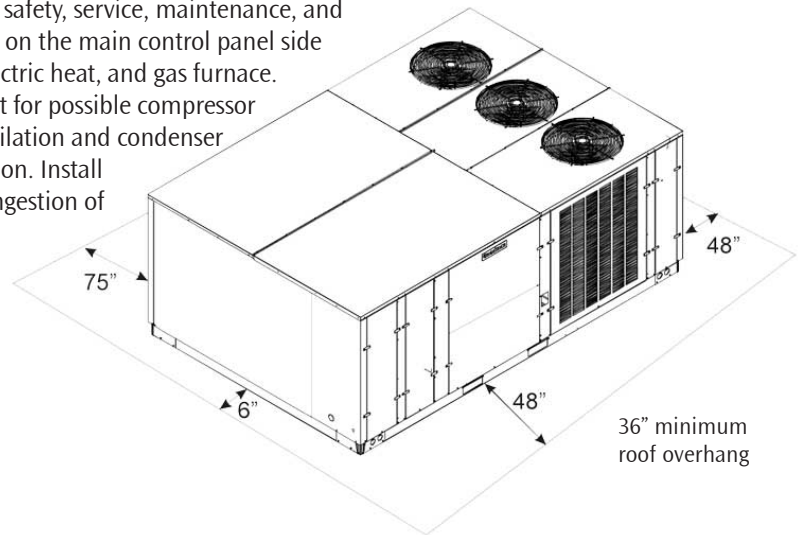

ELECTRICAL ENTRANCE LOCATIONS

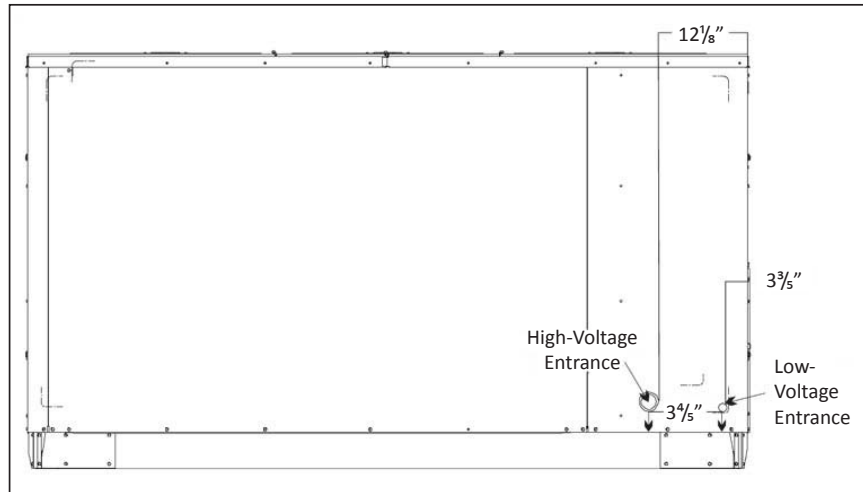

ROOF CURB INSTALLATION — RIGGING

Provisions for forks have been included in the unit base frame. No other fork locations are approved.

- Unit must be lifted by the four lifting holes located at the base frame corners.
- Lifting cables should be attached to the unit with shackles.
- The distance between the crane hook and the top of the unit must not be less than 60”.
- Two spreader bars must span over the unit to prevent damage to the cabinet by the lift cables. Spreader bars must be of sufficient length so that cables do not come in contact with the unit during transport. Remove wood struts mounted beneath unit base frame before setting unit on roof curb. These struts are intended to protect unit base frame from fork lift damage. To remove the struts, extract the sheet metal retainers and pull the struts through the base of the unit. Refer to rigging label on the unit.

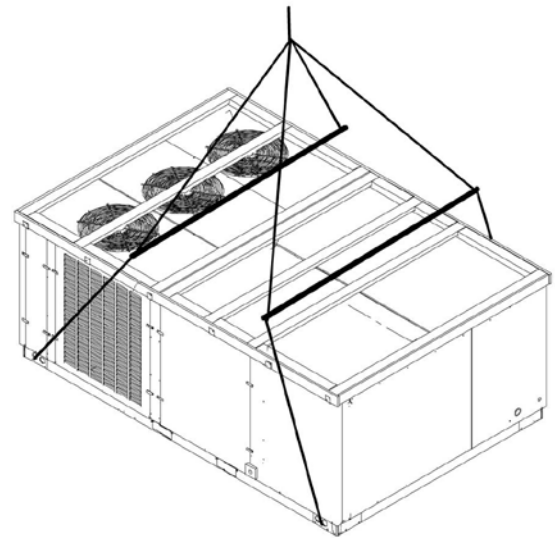

Important: If using bottom discharge with roof curb, duct-work should be attached to the curb prior to installing the unit. Duct-work dimensions are shown in Roof Curb Installation Instructions Manual.

Refer to the Roof Curb Installation Instructions for proper curb installation. Curbing must be installed in compliance with the National Roofing Contractors Association Manual.

Lower unit carefully onto roof mounting curb. While rigging the unit, the center of gravity will cause the condenser end to be lower than the supply air end. Bring condenser end of unit into alignment with the curb. With condenser end of the unit resting on curb member and using curb as a fulcrum, lower opposite end of the unit until entire unit is seated on the curb. When a rectangular cantilever curb is used, take care to center the unit. Check for proper alignment and orientation of supply and return openings with duct.

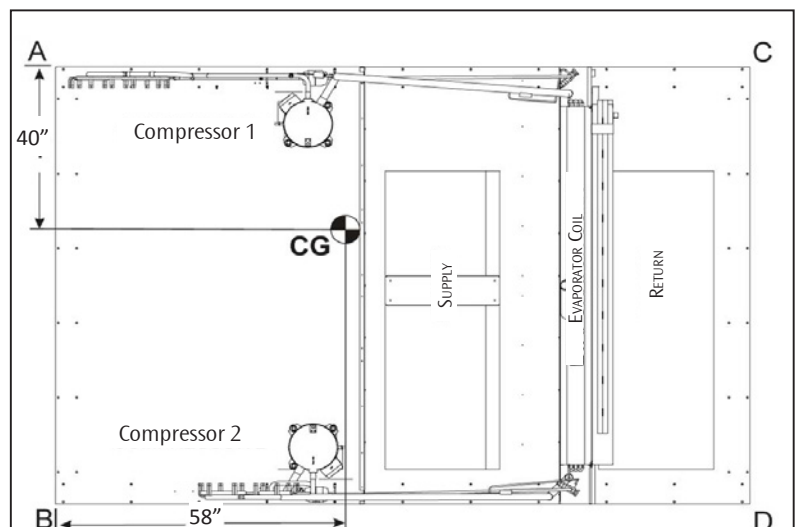

CORNER & CENTER-OF-GRAVITY LOCATIONS

15-TON WEIGHTS

	GAS	COOLER
Weight A	582	590
Weight B	475	582
Weight C	565	492
Weight D	461	401
Shipping Weight	2198	2080
Operating Weight	2083	1965

20-TON WEIGHTS

	GAS	COOLER
Weight A	645	644
Weight B	527	525
Weight C	589	504
Weight D	481	412
Shipping Weight	2357	2202
Operating Weight	2242	2085

To assist in determining rigging requirements, unit weights are shown to the right.

Note: These weights are calculated without installed accessories.

ROOF CURB INSTALLATION

Curb installations must comply with local codes and should follow the established guidelines of the National Roofing Contractors Association.

Proper unit installation requires that the roof curb be firmly and permanently attached to the roof structure. Check for adequate fastening method prior to setting the unit on the curb.

Full perimeter roof curbs are available from the factory and are shipped unassembled. The installing contractor is responsible for field assembly, squaring, leveling, and mounting on the roof structure. All required hardware necessary for the assembly of the sheet metal curb is included in the curb accessory package.

- Determine sufficient structural support before locating and mounting the curb and package unit.
- Duct-work must be constructed using industry guidelines. The duct-work must be placed into the roof curb before mounting the package unit. Our full perimeter curbs include duct connection frames to be assembled with the curb. Cantilevered-type curbs are not available from the factory.
- Contractor furnishes curb insulation, cant strips, flashing, and general roofing material.
- Support curbs on parallel sides with roof members. To prevent damage to the unit, the roof members cannot penetrate supply and return duct openings.

Note: The unit and curb accessories are designed to allow vertical duct installation before unit placement. Duct installation after unit placement is not recommended.

See the manual shipped with the roof curb for assembly and installation instructions.

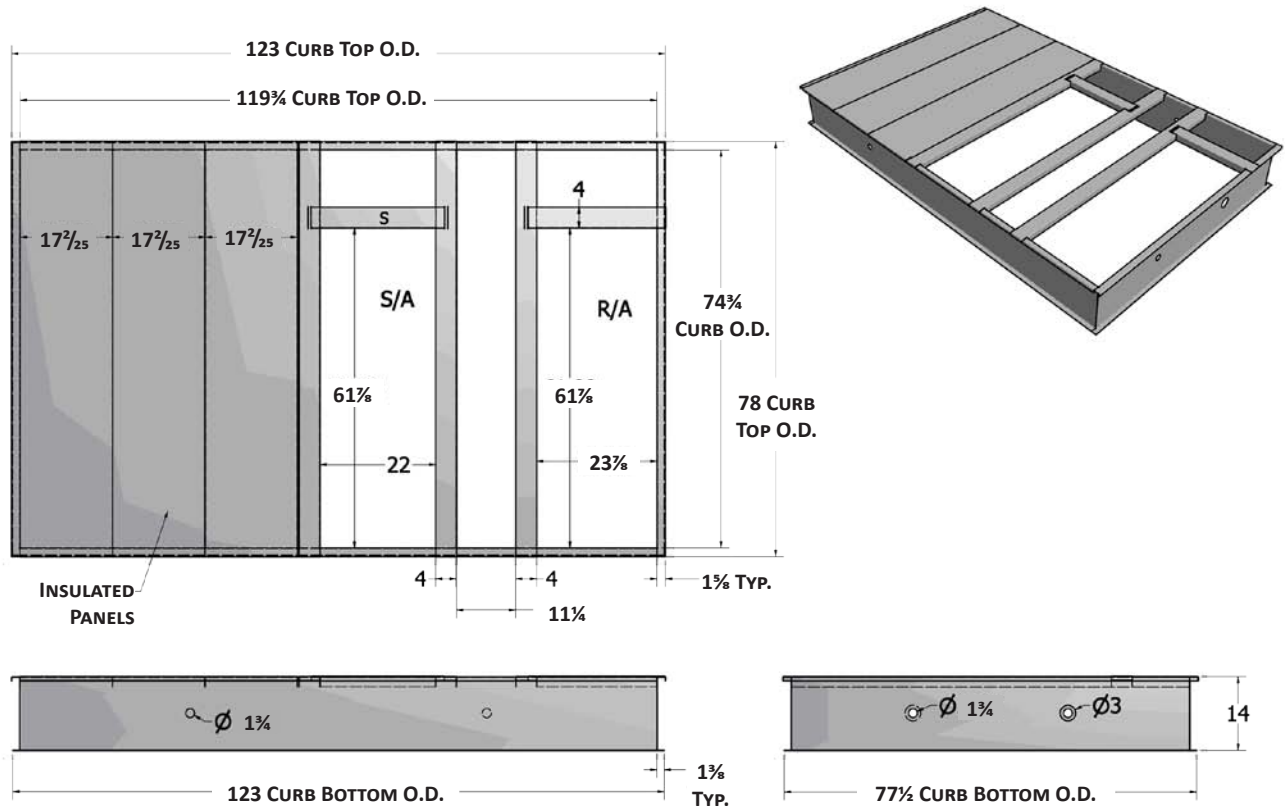

WIRING DIAGRAM — CPG180/240***3B*** THREE-PHASE 208-230 BELT DRIVE

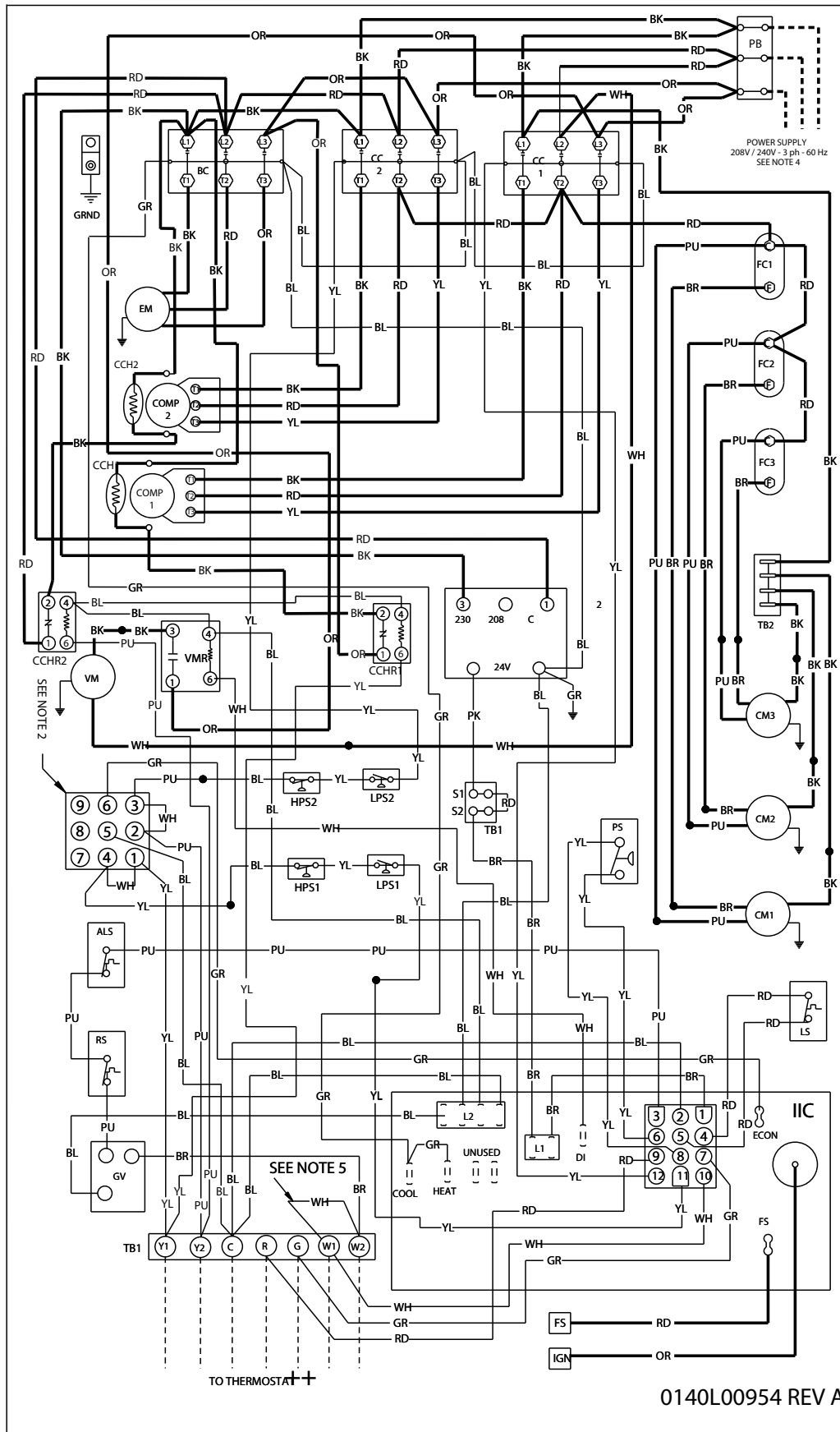

High Voltage: Disconnect all power before servicing or installing this unit. Multiple power sources may be present. Failure to do so may cause property damage, personal injury, or death.

WARNING

Wiring is subject to change. Always refer to the wiring diagram or the unit for the most up-to-date wiring.

WIRING DIAGRAM — CPG180/240***3B*** THREE-PHASE 208-230 BELT DRIVE

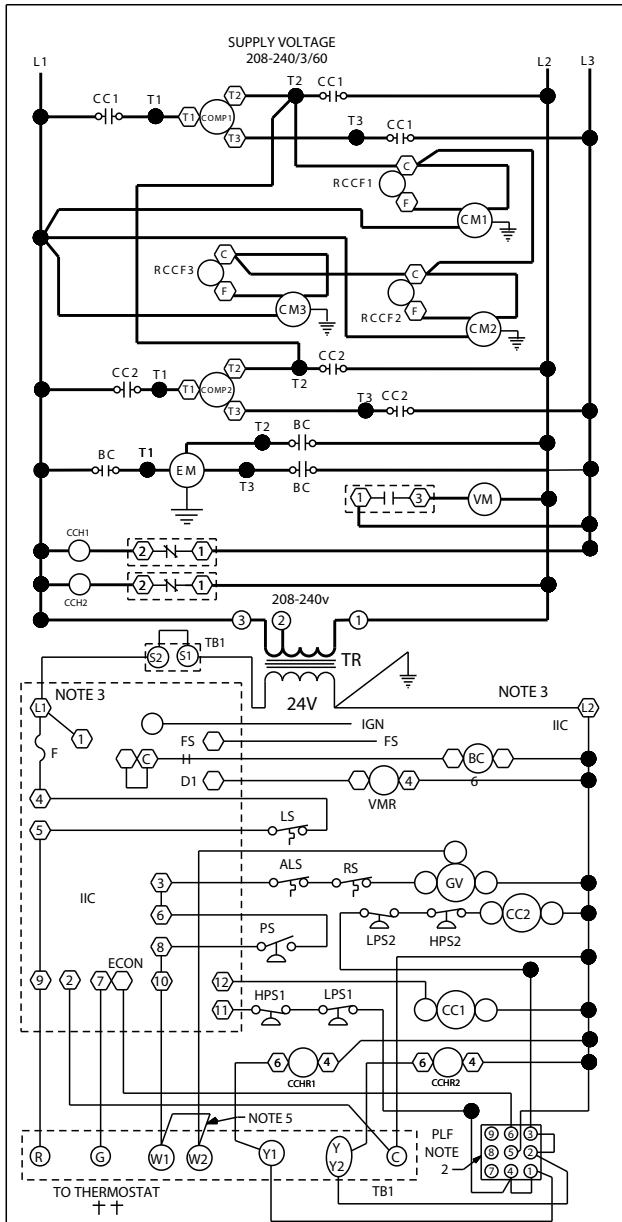

COMPONENT LEGEND

ALS	AUXILIARY LIMIT SWITCH
BC	BLOWER CONTACTOR
COMP	COMPRESSOR
CM	CONDENSER MOTOR
CC	COMPRESSOR CONTACTOR
CCH	CRANK CASE HEATER
CCHR	CRANK CASE HEATER RELAY
EM	EVAPORATOR MOTOR
F	FUSE
FC	FAN CAPACITOR
FS	FLAME SENSOR
GND	EQUIPMENT GROUND
GV	GAS VALVE
HPS	HIGH PRESSURE SWITCH
IBR	INDOOR BLOWER RELAY
IIC	INTEGRATED IGNITION CONTROL
IGN	IGNITOR
LPS	LOW PRESSURE SWITCH
LS	LIMIT SWITCH
PB	POWER DISTRIBUTION BLOCK
PLF	FEMALE PLUG/CONNECTOR
PS	PRESSURE SWITCH
RS	ROLLOUT SWITCH
TB1	TERMINAL BLOCK (24V SIGNAL)
TB2	TERMINAL BLOCK (L1)
TR	TRANSFORMER
VM	VENT MOTOR
VMR	VENT MOTOR RELAY

- NOTES**
- REPLACEMENT WIRE MUST BE THE SAME SIZE AND TYPE OF INSULATION AS ORIGINAL. (USE COPPER CONDUCTOR ONLY).
 - ACCESSORY ECONOMIZER PLUG ADJACENT TO BLOWER HOUSING IN RETURN AIR COMPARTMENT. REMOVE MALE PLUG AND ATTACH FEMALE PLUG TO THE ECONOMIZER ACCESSORY.
 - L1 AND L2 ON IIC CONTROL IS 24V INPUT.
 - USE COPPER CONDUCTORS ONLY.
++ USE NEC CLASS 2 WIRE.
 - FOR TWO STAGE OPERATION REMOVE W1 TO W2 WIRE JUMPER.
 - FOR 208V OPERATION MOVE BLACK WIRE FROM TERMINAL 3 TO TERMINAL 2 ON THE TRANSFORMER.

FACTORY WIRING
 — LINE VOLTAGE
 - - - LOW VOLTAGE
 ···· OPTIONAL
 --- HIGH VOLTAGE

FIELD WIRING
 - - - HIGH VOLTAGE
 - - - LOW VOLTAGE

WIRE CODE

BK	BLACK
BL	BLUE
BR	BROWN
GR	GREEN
OR	ORANGE
PK	PINK
PU	PURPLE
RD	RED
WH	WHITE
YL	YELLOW
YL/PK	YELLOW WITH PINK STRIP
BL/PK	BLUE WITH PINK STRIP

THERMOSTAT FIELD WIRING ++

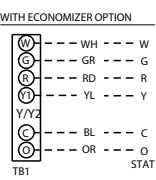
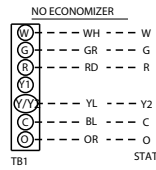
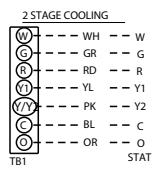

High Voltage: Disconnect all power before servicing or installing this unit. Multiple power sources may be present. Failure to do so may cause property damage, personal injury, or death.

WARNING

Wiring is subject to change. Always refer to the wiring diagram or the unit for the most up-to-date wiring.

INSTALLER/SERVICEMAN

THE STATUS LIGHT ON THE FURNACE CONTROL MAY BE USED AS A GUIDE TO TROUBLESHOOTING THIS APPLIANCE. STATUS LIGHT CODES ARE AS FOLLOWS:

STATUS LIGHT	EQUIPMENT STATUS	CHECK
ON	NORMAL OPERATION	----
OFF	NO POWER OR INTERNAL CONTROL	CHECK INPUT POWER CHECK FUSE ON CONTROL REPLACE CONTROL
1 BLINK	IGNITION FAILURE OPEN ROLLOUT SWITCH OPEN AUX. LIMIT SWITCH	GAS FLOW GAS PRESSURE GAS VALVE FLAME SENSOR FLAME ROLLOUT BAD SWITCH AUX. LIMIT OPEN
2 BLINKS	PRESSURE SWITCH OPEN	CHECK PRESSURE SWITCH
3 BLINKS	PRESSURE SWITCH CLOSED WITHOUT INDUCER ON	CHECK PRESSURE SWITCH
4 BLINKS	OPEN LIMIT SWITCH	MAIN LIMIT OPEN BAD SWITCH
5 BLINKS	FALSE FLAME SENSED	STICKING GAS VALVE
6 BLINKS	COMPRESSOR OUTPUT DELAY	3 MIN. COMP. ANTI-CYCLE TIMER

SEE UNIT RATING PLATE FOR TYPE AND SIZE OF OVER CURRENT PROTECTION

0140L00955 REV A

WIRING DIAGRAM — CPG180/240***B*** THREE-PHASE 208-230 BELT DRIVE

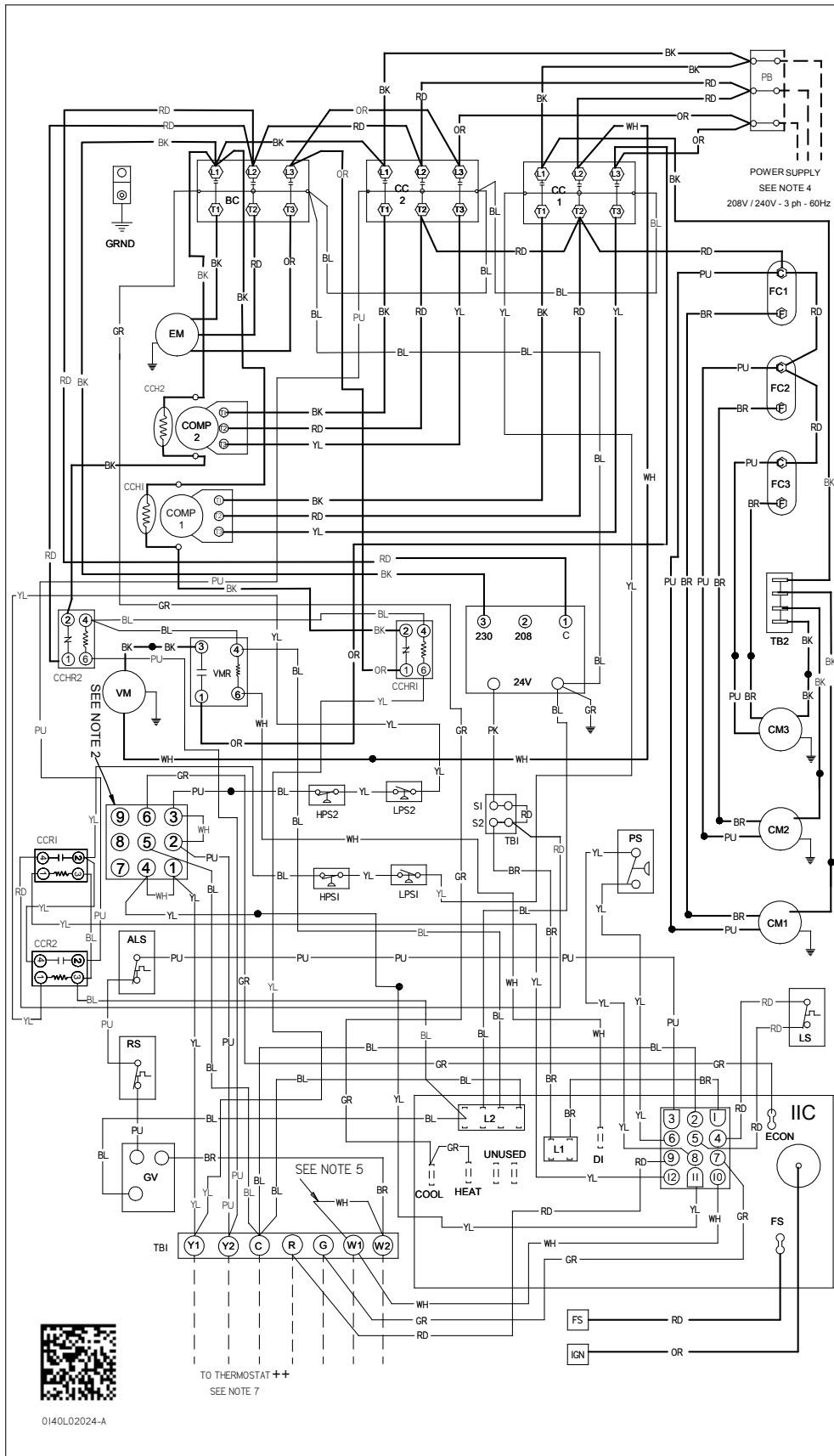

⚡
High Voltage: Disconnect all power before servicing or installing this unit. Multiple power sources may be present. Failure to do so may cause property damage, personal injury, or death.

⚠
WARNING

Wiring is subject to change. Always refer to the wiring diagram or the unit for the most up-to-date wiring.



0140L02024-A

WIRING DIAGRAM — CPG180/240***B*** THREE-PHASE 208-230 BELT DRIVE

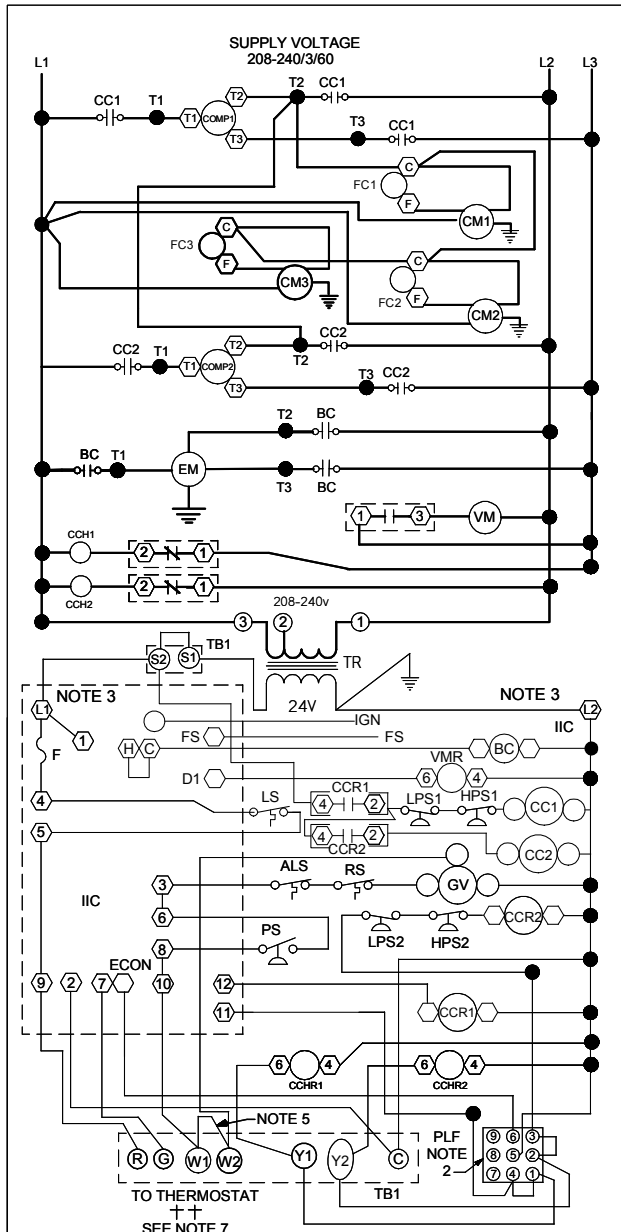

COMPONENT LEGEND

ALS	AUXILIARY LIMIT SWITCH
BC	BLOWER CONTACTOR
COMP	COMPRESSOR
CM	CONDENSER MOTOR
CC	COMPRESSOR CONTACTOR
CCH	CRANK CASE HEATER
CCHR	CRANK CASE HEATER RELAY
CCR	COMPRESSOR CONTACTOR RELAY
EM	EVAPORATOR MOTOR
F	FUSE
FC	FAN CAPACITOR
FS	FLAME SENSOR
GND	EQUIPMENT GROUND
GV	GAS VALVE
HPS	HIGH PRESSURE SWITCH
IBR	INDOOR BLOWER RELAY
IIC	INTEGRATED IGNITION CONTROL
IGN	IGNITOR
LPS	LOW PRESSURE SWITCH
LS	LIMIT SWITCH
PB	POWER DISTRIBUTION BLOCK
PLF	FEMALE PLUG/CONNECTOR
PS	PRESSURE SWITCH
RS	ROLLOUT SWITCH
TB1	TERMINAL BLOCK (24V SIGNAL)
TB2	TERMINAL BLOCK (L1)
TR	TRANSFORMER
VM	VENT MOTOR
VMR	VENT MOTOR RELAY

- NOTES**
- REPLACEMENT WIRE MUST BE THE SAME SIZE AND TYPE OF INSULATION AS ORIGINAL. (USE COPPER CONDUCTOR ONLY).
 - ACCESSORY ECONOMIZER PLUG ADJACENT TO BLOWER HOUSING IN RETURN AIR COMPARTMENT. REMOVE MALE PLUG AND ATTACH FEMALE PLUG TO THE ECONOMIZER ACCESSORY.
 - L1 AND L2 ON IIC CONTROL IS 24V INPUT.
 - USE COPPER CONDUCTORS ONLY.
++ USE NEC CLASS 2 WIRE.
 - FOR TWO STAGE OPERATION REMOVE W1 TO W2 WIRE JUMPER.
 - FOR 208V OPERATION MOVE BLACK WIRE FROM TERMINAL ③ TO TERMINAL ② ON THE TRANSFORMER.
 - IF DDC CONTROL OPTON IS INSTALLED, THERMOSTAT FIELD WIRING IS NOT REQUIRED. SEE DDC CONTROL WIRING DIAGRAM AND INSTRUCTIONS.

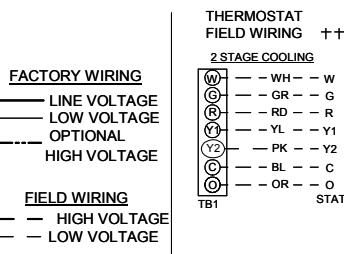

High Voltage: Disconnect all power before servicing or installing this unit. Multiple power sources may be present. Failure to do so may cause property damage, personal injury, or death.

WARNING

INSTALLER/SERVICEMAN

THE STATUS LIGHT ON THE FURNACE CONTROL MAY BE USED AS A GUIDE TO TROUBLESHOOTING THIS APPLIANCE. STATUS LIGHT CODES ARE AS FOLLOWS:

STATUS LIGHT	EQUIPMENT STATUS	CHECK
ON	NORMAL OPERATION	—
OFF	NO POWER OR INTERNAL CONTROL	CHECK INPUT POWER CHECK FUSE ON CONTROL REPLACE CONTROL
1 BLINK	IGNITION FAILURE OPEN ROLLOUT SWITCH OPEN AUX. LIMIT SWITCH	GAS FLOW GAS PRESSURE GAS VALVE FLAME SENSOR FLAME ROLLOUT BAD SWITCH AUX. LIMIT OPEN
2 BLINKS	PRESSURE SWITCH OPEN	CHECK PRESSURE SWITCH
3 BLINKS	PRESSURE SWITCH CLOSED WITHOUT INDUCER ON	CHECK PRESSURE SWITCH
4 BLINKS	OPEN LIMIT SWITCH	MAIN LIMIT OPEN BAD SWITCH
5 BLINKS	FALSE FLAME SENSED	STICKING GAS VALVE
6 BLINKS	COMPRESSOR OUTPUT DELAY	3 MIN. COMP. ANTI-CYCLE TIMER

SEE UNIT RATING PLATE FOR TYPE AND SIZE OF OVER CURRENT PROTECTION



0140L02025-A

WIRING DIAGRAM — CPG180/240***4B/7B*** THREE-PHASE 460/575 BELT DRIVE

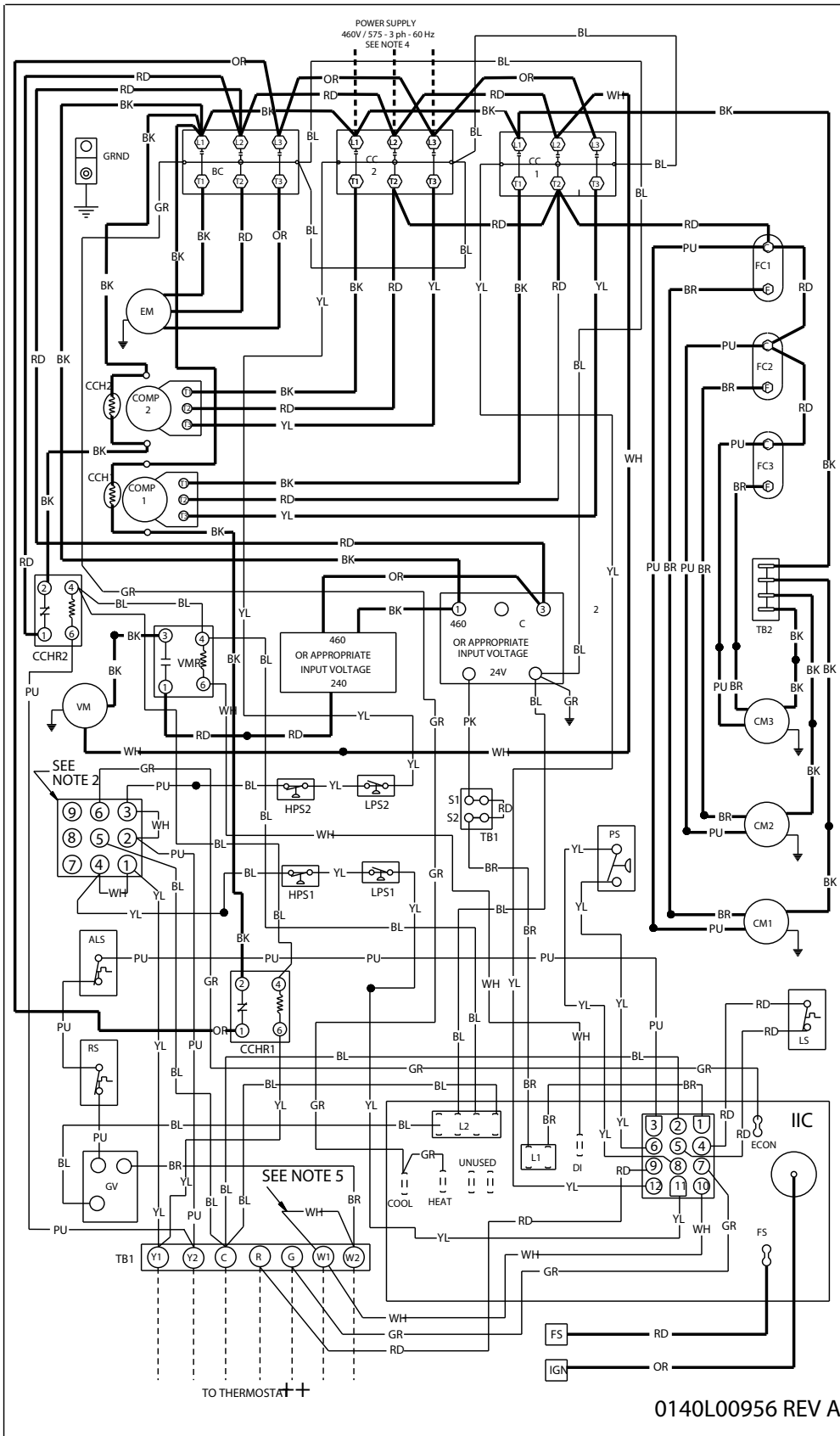

High Voltage: Disconnect all power before servicing or installing this unit. Multiple power sources may be present. Failure to do so may cause property damage, personal injury, or death.

WARNING

Wiring is subject to change. Always refer to the wiring diagram or the unit for the most up-to-date wiring.

WIRING DIAGRAM — CPG180/240***4B/7B*** THREE-PHASE 460/575 BELT DRIVE

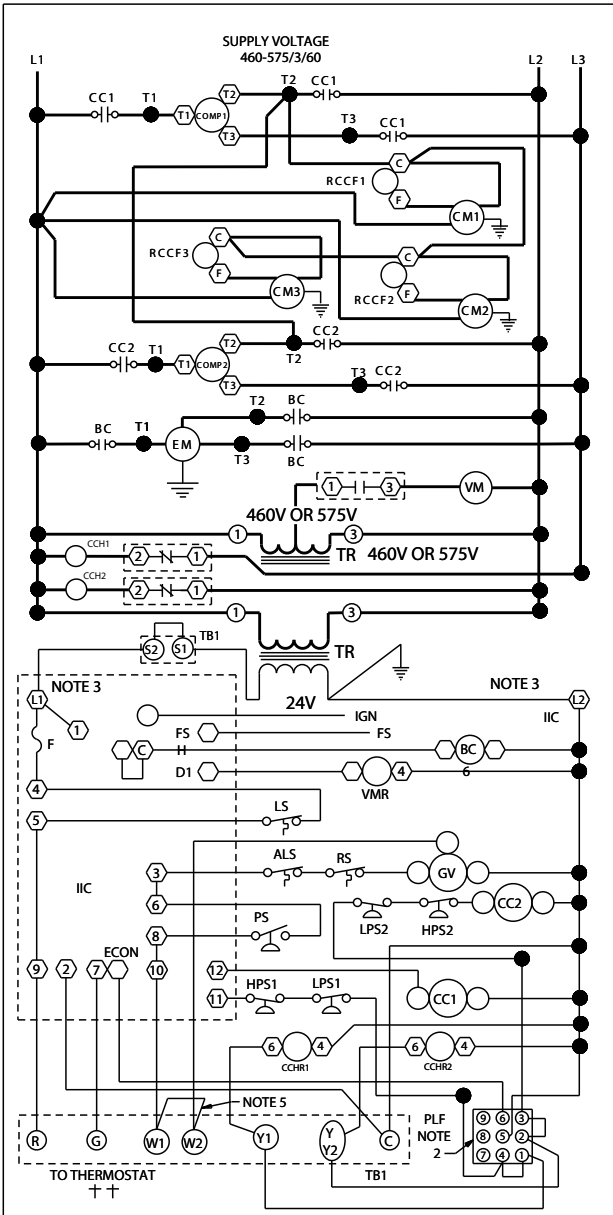

- COMPONENT LEGEND**
- ALS AUXILIARY LIMIT SWITCH
 - BC BLOWER CONTACTOR
 - CCH CRANK CASE HEATER
 - CCHR CRANK CASE HEATER RELAY
 - COMP COMPRESSOR
 - CM CONDENSER MOTOR
 - CC COMPRESSOR CONTACTOR
 - EM EVAPORATOR MOTOR
 - F FUSE
 - FC FAN CAPACITOR
 - FS FLAME SENSOR
 - GND EQUIPMENT GROUND
 - GV GAS VALVE
 - HPS HIGH PRESSURE SWITCH
 - IBR INDOOR BLOWER RELAY
 - IIC INTEGRATED IGNITION CONTROL
 - IGN IGNITOR
 - LPS LOW PRESSURE SWITCH
 - LS LIMIT SWITCH
 - PLF FEMALE PLUG/CONNECTOR
 - PS PRESSURE SWITCH
 - RS ROLL-OUT SWITCH
 - TB1 TERMINAL BLOCK (24V SIGNAL)
 - TB2 TERMINAL BLOCK (L1)
 - TR TRANSFORMER
 - VM VENT MOTOR
 - VMR VENT MOTOR RELAY

- NOTES**
1. REPLACEMENT WIRE MUST BE THE SAME SIZE AND TYPE OF INSULATION AS ORIGINAL. (USE COPPER CONDUCTOR ONLY).
 2. ACCESSORY ECONOMIZER PLUG ADJACENT TO BLOWER HOUSING IN RETURN AIR COMPARTMENT. REMOVE MALE PLUG AND ATTACH FEMALE PLUG TO THE ECONOMIZER ACCESSORY.
 3. L1 AND L2 ON IIC CONTROL IS 24V INPUT.
 4. USE COPPER CONDUCTORS ONLY.
++ USE NEC CLASS 2 WIRE.
 5. FOR TWO STAGE OPERATION REMOVE W1 TO W2 WIRE JUMPER.

FACTORY WIRING
 — LINE VOLTAGE
 - - - LOW VOLTAGE
 · · · OPTIONAL
 --- HIGH VOLTAGE

FIELD WIRING
 - - - HIGH VOLTAGE
 - - - LOW VOLTAGE

- WIRE CODE**
- BK BLACK
 - BL BLUE
 - BR BROWN
 - GR GREEN
 - OR ORANGE
 - PK PINK
 - PU PURPLE
 - RD RED
 - WH WHITE
 - YL YELLOW
 - YL/PK YELLOW WITH PINK STRIP
 - BL/PK BLUE WITH PINK STRIP

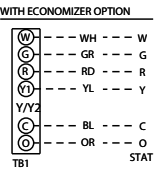
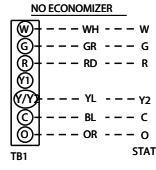
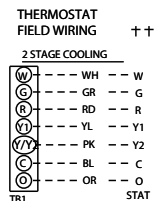

INSTALLER/SERVICEMAN
 THE STATUS LIGHT ON THE FURNACE CONTROL MAY BE USED AS A GUIDE TO TROUBLESHOOTING THIS APPLIANCE. STATUS LIGHT CODES ARE AS FOLLOWS:

STATUS LIGHT	EQUIPMENT STATUS	CHECK
ON	NORMAL OPERATION	---
OFF	NO POWER OR INTERNAL CONTROL	CHECK INPUT POWER CHECK FUSE ON CONTROL REPLACE CONTROL
1 BLINK	IGNITION FAILURE	GAS FLOW GAS PRESSURE GAS VALVE
	OPEN ROLL-OUT SWITCH	FLAME SENSOR
	OPEN AUX. LIMIT SWITCH	FLAME ROLL-OUT BAD SWITCH AUX. LIMIT OPEN
2 BLINKS	PRESSURE SWITCH OPEN	CHECK PRESSURE SWITCH
3 BLINKS	PRESSURE SWITCH CLOSED WITHOUT INDUCER ON	CHECK PRESSURE SWITCH
4 BLINKS	OPEN LIMIT SWITCH	MAIN LIMIT OPEN BAD SWITCH
5 BLINKS	FALSE FLAME SENSED	STICKING GAS VALVE
6 BLINKS	COMPRESSOR OUTPUT DELAY	3 MIN. COMP. ANTI-CYCLE TIMER

SEE UNIT RATING PLATE FOR TYPE AND SIZE OF OVER CURRENT PROTECTION

0140L00957 REV A

High Voltage: Disconnect all power before servicing or installing this unit. Multiple power sources may be present. Failure to do so may cause property damage, personal injury, or death.



Wiring is subject to change. Always refer to the wiring diagram or the unit for the most up-to-date wiring.

ACCESSORIES

FIELD ACCESSORY ITEM #	DESCRIPTION	FITS MODEL SIZES	FIELD- INSTALLED	FACTORY- INSTALLED
14CURB180240	14" Roof Curb	15-20 tons	√	
25FD180240	25% Manual Fresh Air Damper	15-20 tons	√	
25MFD180240	25% Motorized Fresh Air Damper	15-20 tons	√	
DNBBS180240	Burglar Bar Sleeves: Includes Supply and Return	All Models	√	
CDK180	Concentric Duct Kit	15 tons	√	
CDK240	Concentric Duct Kit	20 tons	√	
	Convenience Outlet: Powered	All Models		√
	Convenience Outlet: Non Powered	All Models		√
	Disconnect Switch (non-fused)	All Models		√
DNECONGS180240	Downflow Economizer (for model #s 1210 & below)	15-20 tons	√	√
DNECONGS180240B	Downflow Economizer	15-20 tons	√	√
	Electric Heat Kits		√	√
HAKT36300	High-Altitude Kit	All Models	√	
HSKT180G	High-Static Kit	15 tons	√	
HSKT240	High-Static Kit	20 tons	√	
	Horizontal Barometric Relief Damper	15-20 tons	√	
HZCURB180240ED	Horizontal Discharge Curb — End Discharge	15-20 tons		
HZCURB180240SDN	Horizontal Discharge Curb — Side Discharge; duct openings on non-service side	15-20 tons		
HZCURB180240SDS	Horizontal Discharge Curb — Side Discharge; duct openings on service side	15-20 tons		
GHRC-1	Hurricane Restraint Clip	All Models	√	
LAKT03	Low-Ambient Kit	15-20 tons	√	√
LPKT180300	LP Conversion Kit	15-20 tons	√	
PE1802402	Power Exhaust 208/230v	15-20 tons	√	
PE1802404	Power Exhaust 460v	15-20 tons	√	
	Smoke Detector	All Models		√
	Stainless-Steel Heat Exchanger (Type 409)	15-20 tons		√



NOTES

NOTES

NOTES