



Air Conditioning & Heating

GPH15M

PACKAGED HEAT PUMP

R-410A

2 TO 5 TONS

UP TO 15 SEER

UP TO 8.0 HSPF

COOLING CAPACITY: 24,000 - 55,600 BTU/H

HEATING CAPACITY: 23,400 - 56,000 BTU/H

Standard Features

- High-efficiency compressor with internal relief valve
- Fully charged R-410A system
- EEM (X-13) blower motor
- Liquid-line filter dryer
- Convertible airflow — horizontal or downflow
- Copper tube/aluminum fin coils
- Electric heat kit available as a field-installed option
- AHRI Certified; ETL Listed



Cabinet Features

- Heavy-gauge galvanized-steel cabinet with attractive Architectural Gray powder-paint finish
- Fully insulated air-handling compartment with convenient access panels
- Louvered condenser coil protection
- One footprint; two heights

Contents

Nomenclature	2
Product Specifications	3
Expanded Cooling Data	4
Airflow Data	28
Expanded Heating Data	30
Auxiliary Heating Data	33
Heat Kit Electrical Specs	35
Dimensions	36
Wiring Diagrams	37
Accessories	39



* Complete warranty details available from you local dealer or at www.goodmanmfg.com. To receive the 10-Year Parts Limited Warranty, online registration must be completed within 60 days of installation. Online registration is not required in California or Québec.



NOMENCLATURE

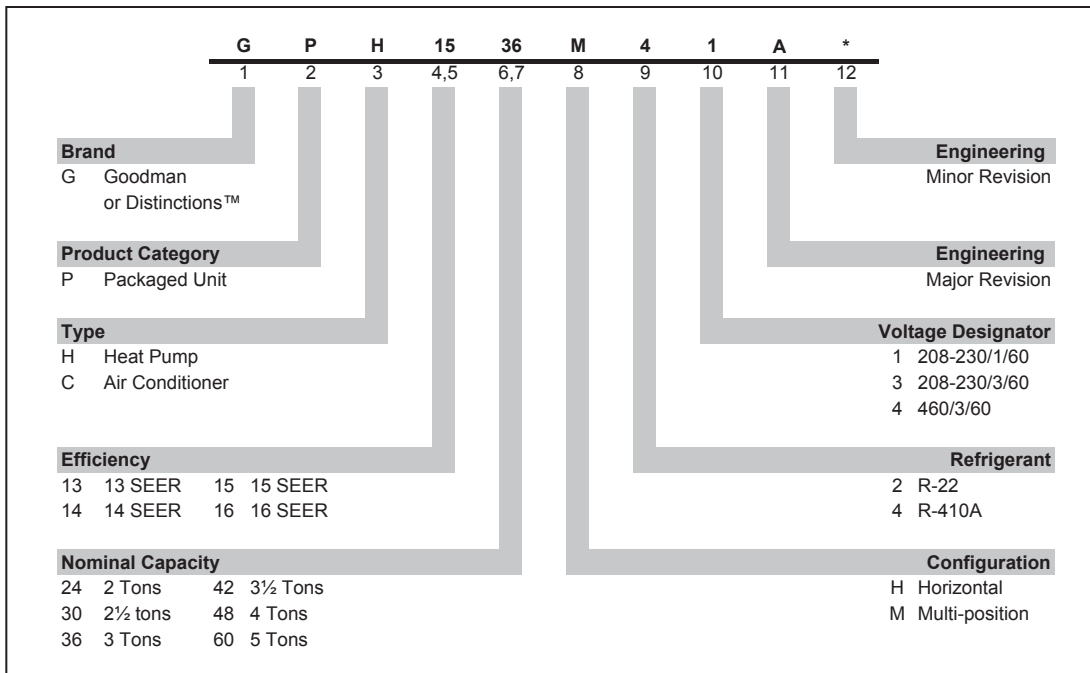

ACCESSORIES

ITEM	DESCRIPTION
20464501PDGK	Horizontal Duct Cover for Medium Chassis
20464502PDGK	Horizontal Duct Cover for Large Chassis
GPH13MED102/ 103*	Downflow Economizer for Medium/ Large Chassis
GPH13MFR102/ 103*	Internal filter rack for Medium/ Large Chassis — Downflow Applications
OT18-60A	Outdoor Thermostat Kit with Lockout Stat
OT/EHR18-60	Emergency Heat Relay kit
PCFR102/ 103	External Horizontal Filter Rack for Medium/ Large Chassis
PGC102/ 103*	Roof Curb for for Medium/ Large Chassis
PGMDD102*	Manual Damper for Downflow Application — Medium Chassis
PGMDMD102*	Motorized Damper for Downflow Application — Medium Chassis
PGMDD103*	Manual Damper for Downflow Application — Large Chassis
PGMDMD103*	Motorized Damper for Downflow Application — Large Chassis
PGMDH102*	Manual 25% Fresh Air Damper for Medium Chassis — Horizontal Applications
PGMDH103*	Manual 25% Fresh Air Damper for Large Chassis — Horizontal Applications
PGMDMH102*	Motorized 25% Fresh Air Damper for Medium Chassis — Horizontal Applications
PGMDMH103*	Motorized 25% Fresh Air Damper for Large Chassis — Horizontal Applications
SQRPG102*	Square-to-Round Adapter with 16" Round for Medium Chassis — Downflow Applications
SQRPG103*	Square-to-Round Adapter with 18" Round for Large Chassis — Downflow Applications
SQRPGH102*	Square-to-Round Adapters for Medium Chassis — 16½" & 16½"
SQRPGH103*	Square-to-Round Adapters for Large Chassis — 18" & 18"

* Offered by McDaniel Metals • Main: (281) 987-8400 • Fax: (281) 987-9494

SPECIFICATIONS

	GPH15 24M41**	GPH15 30M41**	GPH15 36M41**	GPH15 42M41**	GPH15 43M41**	GPH15 48M41**	GPH15 49M41**	GPH15 60M41**
COOLING CAPACITY								
Total BTU/h	24,000	29,000	35,400	41,000	40,000	46,500	46,000	55,500
Sensible BTU/h	18,000	22,200	26,700	29,000	28,000	35,600	31,000	39,300
SEER / EER	15/ 12	15/ 12	15/ 12	15/ 11	15 / 12	15/ 11.3	15 / 12	14/ 10.2
Decibels	76	76	76	76	78	78	78	78
AHRI #s	1358754	3160143	1358755	3195398	3479850	1358756	3481440	1358757
HEATING CAPACITY								
BUT/h (47°F)	23,400	27,400	35,400	40,000	39,000	45,500	45,500	56,000
C.O.P (47°F)	3.5	3.6	3.5	3.5	3.75	3.4	3.6	3.3
BUT/h (17°F)	12,400	15,200	18,600	20,000	22,000	24,600	25,000	31,400
C.O.P (17°F)	2.2	2.3	2.4	2.2	2.5	2.1	2.2	2.1
HSPF	8.0	8.0	8.0	8.0	8.0	8.0	8.0	8.0
EVAPORATOR MOTOR								
Type	X-13	X-13	X-13	X-13	X-13	X-13	X-13	X-13
Wheel (D x W)	10 x 9	10 x 9	10 x 9	10 x 9	10 x 9	10 x 9	10 x 9	10 x 9
Nominal Cooling CFM	860	1,000	1,200	1,250	1,250	1,700	1,350	1,800
FLA	4.1	4.1	4.1	4.1	2.9	5.8	2.9	7.6
No. of Speeds	5	5	5	5	5	5	5	5
Horsepower - RPM	½ -1,050	½ -1,050	½ -1,050	½ -1,075	¾ - 1,050	¾ - 1,050	¾ - 1,050	1-1,050
EVAPORATOR COIL								
Face Area (ft²)	4.5	4.5	4.5	4.5	6.2	6.2	6.2	6.2
Rows Deep/ Fin per Inch	3/ 14	3/ 14	4/ 14	4/ 14	4/ 14	4/ 14	4/ 14	4/ 14
Expansion Device	TXV	TXV	TXV	TXV	TXV	TXV	TXV	TXV
Drain Size (NPT)	¾"	¾"	¾"	¾"	¾"	¾"	¾"	¾"
R-410A Refrigerant Charge (oz.)	113	128	174	193	233	214	214	207
CONDENSER FAN / COIL								
Horsepower - RPM	¼ - 850	¼ - 850	¼ - 850	¼ - 850	¼ - 1,075	½ - 1,075	¾ - 1,075	¾ - 1,075
FLA/LRA	1.5/ 3.0	1.5/ 3.0	1.5/ 3.0	1.5/ 3.0	1.4 / 2.9	2.4/ 5.2	1.4 / 2.9	2.4/ 5.2
Fan Diameter / # Fan Blades	22 / 3	22 / 3	22 / 3	22 / 3	22 / 3	22 / 3	22 / 3	22 / 3
Face Area (ft²)	17.2	17.2	17.2	17.2	21.2	21.2	21.2	21.2
Rows Deep/ Fin per Inch	1 / 22	1 / 22	2 / 16	2 / 16	2 / 16	2 / 18	2 / 16	2 / 18
COMPRESSOR								
Quantity	1	1	1	1	1	1	1	1
Type	Scroll	Scroll	Scroll	Scroll	Scroll	Scroll	Scroll	Scroll
Stage	Single	Single	Single	Two	Single	Two	Two	Two
ELECTRICAL DATA								
Voltage/ Phase/ Hz	208-230/1/60		208-230/1/60		208-230/1/60		208-230/1/60	
Compressor RLA/ LRA	12.8 / 58	14.1 / 73	16.7 / 79	16.7 / 96	17.9 / 112	21.2 / 96	21.2 / 96	25.6 / 118
Indoor Blower FLA	4.1	4.1	4.1	4.1	2.9	5.8	2.9	7.6
Total Unit Amps	18.4	19.7	22.3	22.3	22.2	29.4	25.5	35.6
Min. Circuit Ampacity ¹	21.6	23.2	26.5	26.5	26.7	34.8	30.8	42.1
Max. Overcurrent Protection ²	30	35	40	40	40	50	50	60
SHIPPING WEIGHT (LBS)	376	385	438	460	492	492	492	523

¹ Wire size should be determined in accordance with National Electrical Codes. Extensive wire runs will require larger wire sizes.

² May use fuses or HACR-type circuit breakers of the same size as noted.

Note: Always check the S&R plate for electrical data on the unit being installed.

EXPANDED COOLING DATA — GPH1524M41*

IDB	AIRFLOW	OUTDOOR AMBIENT TEMPERATURE												ENTERING INDOOR WET BULB TEMPERATURE											
		65°F				75°F				85°F				95°F				105°F				115°F			
		59	63	67	71	59	63	67	71	59	63	67	71	59	63	67	71	59	63	67	71	59	63	67	71
70	MBh	23.5	24.4	26.7	-	23.0	23.8	26.1	-	22.4	23.2	25.5	-	21.9	22.7	24.8	-	20.8	21.5	23.6	-	19.3	20.0	21.9	-
	S/T	0.77	0.64	0.45	-	0.80	0.67	0.46	-	0.82	0.68	0.47	-	0.85	0.71	0.49	-	0.88	0.73	0.51	-	0.88	0.74	0.51	-
	ΔT	17	15	11	-	17	15	11	-	17	15	11	-	18	15	12	-	17	15	11	-	16	14	11	-
	kW	1.60	1.63	1.68	-	1.72	1.76	1.81	-	1.82	1.86	1.92	-	1.91	1.96	2.02	-	1.99	2.04	2.10	-	2.06	2.10	2.17	-
	Amps	7.5	7.7	7.9	-	8.0	8.2	8.4	-	8.5	8.7	8.9	-	9.0	9.2	9.4	-	9.5	9.7	9.9	-	9.9	10.1	10.4	-
	Hi PR	216	232	245	-	242	261	275	-	275	296	313	-	314	337	356	-	353	380	401	-	390	419	443	-
	Lo PR	106	113	124	-	112	120	131	-	117	124	136	-	123	131	143	-	129	137	149	-	133	142	155	-
	MBh	22.8	23.7	25.9	-	22.3	23.1	25.3	-	21.8	22.6	24.7	-	21.2	22.0	24.1	-	20.2	20.9	22.9	-	18.7	19.4	21.2	-
	S/T	0.73	0.61	0.43	-	0.76	0.64	0.44	-	0.78	0.65	0.45	-	0.81	0.67	0.47	-	0.84	0.70	0.48	-	0.84	0.70	0.49	-
	ΔT	18	16	12	-	18	16	12	-	18	16	12	-	18	16	12	-	18	16	12	-	17	15	11	-
	kW	1.59	1.62	1.67	-	1.71	1.74	1.80	-	1.81	1.85	1.90	-	1.90	1.94	2.00	-	1.98	2.02	2.08	-	2.04	2.09	2.15	-
	Amps	7.5	7.6	7.8	-	8.0	8.1	8.3	-	8.5	8.6	8.9	-	8.9	9.1	9.4	-	9.4	9.6	9.8	-	9.8	10.0	10.3	-
Hi PR	214	230	243	-	240	258	272	-	273	293	310	-	310	334	353	-	349	376	397	-	386	415	439	-	
Lo PR	105	112	122	-	111	118	129	-	116	123	134	-	122	129	141	-	127	135	148	-	132	140	153	-	
MBh	21.1	21.8	23.9	-	20.6	21.3	23.4	-	20.1	20.8	22.8	-	19.6	20.3	22.3	-	18.6	19.3	21.1	-	17.3	17.9	19.6	-	
S/T	0.71	0.59	0.41	-	0.73	0.61	0.42	-	0.75	0.63	0.44	-	0.78	0.65	0.45	-	0.81	0.67	0.47	-	0.81	0.68	0.47	-	
ΔT	18	16	12	-	19	16	12	-	19	16	12	-	19	16	12	-	18	16	12	-	17	15	11	-	
kW	1.55	1.59	1.63	-	1.67	1.70	1.75	-	1.77	1.80	1.86	-	1.85	1.89	1.95	-	1.93	1.97	2.03	-	1.99	2.04	2.10	-	
Amps	7.3	7.5	7.7	-	7.8	7.9	8.1	-	8.3	8.5	8.7	-	8.7	8.9	9.1	-	9.2	9.4	9.6	-	9.6	9.8	10.1	-	
Hi PR	207	223	235	-	232	250	264	-	264	285	300	-	301	324	342	-	339	365	385	-	374	403	425	-	
Lo PR	102	109	119	-	108	115	125	-	112	119	130	-	118	125	137	-	124	131	143	-	128	136	148	-	

75	MBh	23.9	24.6	26.7	28.6	23.4	24.1	26.0	27.9	22.8	23.5	25.4	27.3	22.2	22.9	24.8	26.6	21.1	21.8	23.6	25.3	19.6	20.2	21.8	23.4
	S/T	0.88	0.78	0.59	0.38	0.91	0.81	0.61	0.40	0.93	0.83	0.63	0.41	0.96	0.86	0.65	0.42	1.00	0.89	0.67	0.43	1.00	0.90	0.68	0.44
	ΔT	20	18	15	10	20	19	15	10	20	19	15	10	20	19	15	11	20	18	15	10	19	17	14	10
	kW	1.62	1.65	1.70	1.75	1.73	1.77	1.82	1.88	1.84	1.88	1.94	2.00	1.93	1.97	2.03	2.10	2.01	2.05	2.12	2.19	2.08	2.12	2.19	2.26
	Amps	7.6	7.7	7.9	8.2	8.1	8.2	8.4	8.7	8.6	8.8	9.0	9.3	9.1	9.3	9.5	9.8	9.5	9.7	10.0	10.3	10.0	10.2	10.5	10.8
	Hi PR	218	235	248	258	245	263	278	290	278	299	316	330	317	341	360	375	356	383	405	422	394	424	447	467
	Lo PR	107	114	125	133	114	121	132	140	118	126	137	146	124	132	144	153	130	138	151	161	134	143	156	166
	MBh	23.2	23.9	25.9	27.8	22.7	23.4	25.3	27.1	22.1	22.8	24.7	26.5	21.6	22.2	24.1	25.8	20.5	21.1	22.9	24.5	19.0	19.6	21.2	22.7
	S/T	0.84	0.75	0.57	0.36	0.87	0.77	0.59	0.38	0.89	0.79	0.60	0.39	0.92	0.82	0.62	0.40	0.95	0.85	0.64	0.41	0.96	0.86	0.65	0.42
	ΔT	21	19	16	11	21	19	16	11	21	19	16	11	21	19	16	11	21	19	16	11	19	18	15	10
	kW	1.60	1.64	1.68	1.74	1.72	1.76	1.81	1.87	1.82	1.86	1.92	1.98	1.92	1.96	2.02	2.08	1.99	2.04	2.10	2.17	2.06	2.10	2.17	2.24
	Amps	7.5	7.7	7.9	8.1	8.0	8.2	8.4	8.6	8.5	8.7	8.9	9.2	9.0	9.2	9.4	9.7	9.5	9.7	9.9	10.2	9.9	10.1	10.4	10.7
Hi PR	216	232	245	256	242	261	275	287	275	296	313	326	314	338	356	372	353	380	401	418	390	420	443	462	
Lo PR	106	113	124	132	112	120	131	139	117	124	136	145	123	131	143	152	129	137	149	159	133	142	155	165	
MBh	21.4	22.1	23.9	25.6	20.9	21.6	23.3	25.0	20.4	21.0	22.8	24.4	19.9	20.5	22.2	23.8	18.9	19.5	21.1	22.7	17.5	18.1	19.6	21.0	
S/T	0.81	0.72	0.55	0.35	0.83	0.75	0.56	0.36	0.86	0.77	0.58	0.37	0.88	0.79	0.60	0.38	0.92	0.82	0.62	0.40	0.92	0.83	0.63	0.40	
ΔT	21	19	16	11	21	20	16	11	21	20	16	11	22	20	16	11	22	20	16	11	20	18	15	10	
kW	1.57	1.60	1.65	1.70	1.68	1.71	1.77	1.82	1.78	1.82	1.87	1.93	1.87	1.91	1.97	2.03	1.94	1.99	2.05	2.12	2.01	2.05	2.12	2.19	
Amps	7.4	7.5	7.7	7.9	7.8	8.0	8.2	8.4	8.4	8.5	8.7	9.0	8.8	9.0	9.2	9.5	9.3	9.4	9.7	10.0	9.7	9.9	10.2	10.5	
Hi PR	209	225	238	248	235	253	267	278	267	287	304	317	304	327	346	361	342	368	389	406	378	407	430	448	
Lo PR	103	110	120	128	109	116	127	135	113	121	132	140	119	127	138	147	125	133	145	154	129	137	150	160	

IDB: Entering Indoor Dry Bulb Temperature
 High & low pressures are measured at the liquid & suction access fittings.
 Shaded area reflects ACCA (TVA) conditions
 kW = Total system power
 Amps = outdoor unit amps (comp.+ fans)

EXPANDED COOLING DATA — GPH1524M41* (CONT.)

IDB	AIRFLOW	OUTDOOR AMBIENT TEMPERATURE															ENTERING INDOOR WET BULB TEMPERATURE																																		
		65°F					75°F					85°F					95°F					105°F					115°F																								
		59	63	67	71	75	59	63	67	71	75	59	63	67	71	75	59	63	67	71	75	59	63	67	71	75	59	63	67	71	75																				
80	970	MBh	24.3	24.9	26.6	28.4	23.8	24.3	26.0	27.7	23.2	23.7	25.3	27.1	22.6	23.1	24.7	26.4	21.5	22.0	23.5	25.1	19.9	20.4	21.8	23.3	S/T	0.96	0.90	0.73	0.55	1.00	0.93	0.76	0.57	1.00	0.96	0.78	0.58	1.00	0.90	0.80	0.60	1.00	1.00	0.83	0.62	1.00	1.00	0.84	0.63
		ΔT	22	21	18	15	23	21	19	15	22	22	19	15	21	22	19	15	20	21	19	15	20	19	17	14	kW	1.63	1.66	1.71	1.76	1.75	1.78	1.84	1.90	1.85	1.89	1.95	2.01	1.95	1.99	2.05	2.12	2.03	2.07	2.13	2.20	2.09	2.14	2.21	2.28
	Amps	7.7	7.8	8.0	8.2	8.1	8.3	8.5	8.7	8.7	8.8	9.1	9.3	9.1	9.3	9.6	9.9	9.6	9.6	9.8	10.1	10.4	10.1	10.3	10.6	10.9	Hi PR	220	237	250	261	247	266	281	293	281	302	319	333	320	344	364	379	360	387	409	427	398	428	452	471
	Lo PR	109	116	126	134	115	122	133	142	119	127	138	147	125	133	145	155	131	140	152	162	162	136	144	158	168	MBh	23.6	24.1	25.8	27.6	23.1	23.6	25.2	26.9	22.5	23.0	24.6	26.3	22.0	22.5	24.0	25.7	20.9	21.3	22.8	24.4	19.3	19.8	21.1	22.6
	S/T	0.92	0.86	0.70	0.52	0.95	0.89	0.72	0.54	0.97	0.91	0.74	0.56	1.00	0.94	0.77	0.57	1.00	0.98	0.80	0.60	1.00	0.99	0.80	0.60	ΔT	23	22	19	15	23	22	20	16	23	22	20	16	24	23	20	16	22	22	19	16	21	21	18	14	
	kW	1.62	1.65	1.70	1.75	1.73	1.77	1.82	1.88	1.84	1.88	1.94	2.00	1.93	1.97	2.03	2.10	2.01	2.05	2.12	2.19	2.08	2.12	2.19	2.26	Amps	7.6	7.7	7.9	8.2	8.1	8.2	8.4	8.7	8.6	8.8	9.0	9.3	9.1	9.3	9.5	9.8	9.5	9.7	10.0	10.3	10.0	10.2	10.5	10.8	
	Hi PR	218	235	248	258	245	263	278	290	278	299	316	330	317	341	360	375	356	384	405	422	394	424	447	467	Lo PR	107	114	125	133	114	121	132	140	118	126	137	146	124	132	144	153	130	138	151	161	134	143	156	166	
	MBh	21.8	22.3	23.8	25.5	21.3	21.8	23.3	24.9	20.8	21.3	22.7	24.3	20.3	20.7	22.2	23.7	19.3	19.7	21.0	22.5	17.9	18.2	19.5	20.8	S/T	0.88	0.83	0.67	0.50	0.92	0.86	0.70	0.52	0.94	0.88	0.72	0.54	0.97	0.91	0.74	0.55	1.01	0.94	0.77	0.57	1.01	0.95	0.77	0.58	
	ΔT	24	23	20	16	24	23	20	16	24	23	20	16	24	23	20	16	24	23	20	16	22	21	18	15	kW	1.58	1.61	1.66	1.71	1.69	1.73	1.78	1.84	1.79	1.83	1.89	1.95	1.88	1.92	1.98	2.05	1.96	2.00	2.07	2.13	2.03	2.07	2.14	2.21	
	Amps	7.4	7.6	7.8	8.0	7.9	8.0	8.2	8.5	8.4	8.6	8.8	9.1	8.9	9.0	9.3	9.6	9.3	9.5	9.8	10.1	9.8	10.0	10.2	10.6	Hi PR	211	228	240	251	237	255	270	281	270	290	307	320	307	331	349	364	346	372	393	410	382	411	434	453	
Lo PR	104	111	121	129	110	117	128	136	114	122	133	142	120	128	140	149	126	134	146	156	130	139	151	161																											

85	970	MBh	24.8	25.2	26.4	28.2	24.2	24.7	25.8	27.6	23.6	24.1	25.2	26.9	23.0	23.5	24.6	26.2	21.9	22.3	23.4	24.9	20.3	20.7	21.6	23.1	S/T	1.00	0.97	0.88	0.71	1.00	1.00	0.91	0.74	1.00	1.00	0.93	0.76	1.00	1.00	0.96	0.78	1.00	1.00	1.00	0.81	1.00	1.00	0.82
		ΔT	23	23	22	19	23	23	22	19	22	23	22	19	22	22	22	19	21	21	22	19	19	20	21	18	kW	1.64	1.67	1.72	1.78	1.76	1.80	1.85	1.91	1.87	1.91	1.97	2.03	1.96	2.00	2.07	2.13	2.04	2.09	2.15	2.22	2.11	2.16	2.23
	Amps	7.7	7.8	8.0	8.3	8.2	8.3	8.5	8.8	8.7	8.9	9.1	9.4	9.2	9.4	9.6	9.9	9.7	9.9	10.1	10.5	10.2	10.4	10.6	11.0	Hi PR	222	239	253	264	249	268	284	296	284	305	322	336	323	348	367	383	364	391	413	431	402	432	456	476
	Lo PR	110	117	127	136	116	123	135	143	120	128	140	149	126	135	147	156	133	141	154	164	137	146	159	170	MBh	24.0	24.5	25.7	27.4	23.5	23.9	25.1	26.8	22.9	23.4	24.5	26.1	22.4	22.8	23.9	25.5	21.2	21.7	22.7	24.2	19.7	20.1	21.0	22.4
	S/T	0.96	0.93	0.84	0.68	1.00	0.96	0.87	0.70	1.00	0.98	0.89	0.72	1.00	1.00	0.92	0.74	1.00	1.00	0.95	0.77	1.00	1.00	0.96	0.78	ΔT	25	24	23	20	25	25	23	20	24	24	23	20	24	24	23	20	23	23	23	20	21	21	22	19
	kW	1.63	1.66	1.71	1.76	1.75	1.78	1.84	1.90	1.85	1.89	1.95	2.01	1.95	1.99	2.05	2.12	2.03	2.07	2.13	2.20	2.09	2.14	2.21	2.28	Amps	7.7	7.8	8.0	8.2	8.1	8.3	8.5	8.7	8.7	8.8	9.1	9.3	9.1	9.3	9.6	9.9	9.6	9.8	10.1	10.4	10.1	10.3	10.6	10.9
	Hi PR	220	237	250	261	247	266	281	293	281	302	319	333	320	344	364	379	360	387	409	427	398	428	452	471	Lo PR	109	116	126	134	115	122	133	142	119	127	138	147	125	133	145	155	131	140	152	162	136	144	158	168
	MBh	22.2	22.6	23.7	25.3	21.7	22.1	23.1	24.7	21.2	21.6	22.6	24.1	20.6	21.0	22.0	23.5	19.6	20.0	20.9	22.3	18.2	18.5	19.4	20.7	S/T	0.93	0.89	0.81	0.65	0.96	0.93	0.84	0.68	0.98	0.95	0.86	0.70	1.00	0.98	0.88	0.72	1.00	1.00	0.92	0.74	1.00	1.00	0.93	0.75
	ΔT	25	25	23	20	26	25	24	21	26	25	24	21	25	25	24	21	24	25	24	20	22	23	22	19	kW	1.59	1.62	1.67	1.72	1.71	1.74	1.79	1.85	1.81	1.85	1.90	1.96	1.90	1.94	2.00	2.07	1.98	2.02	2.08	2.15	2.04	2.09	2.15	2.22
	Amps	7.5	7.6	7.8	8.0	8.0	8.1	8.3	8.5	8.5	8.6	8.9	9.1	8.9	9.1	9.4	9.6	9.4	9.6	9.8	10.1	9.8	10.0	10.3	10.6	Hi PR	214	230	243	253	240	258	272	284	273	293	310	323	310	334	353	368	349	376	397	414	386	415	438	457
Lo PR	105	112	122	130	111	118	129	138	116	123	134	143	121	129	141	150	127	135	148	157	132	140	153	163																										

IDB: Entering Indoor Dry Bulb Temperature
 High & low pressures are measured at the liquid & suction access fittings.

Shaded area reflects AHRI (TVA) conditions

kW = Total system power
 Amps = outdoor unit amps (comp.+ fans)

EXPANDED COOLING DATA — GPH1530M41*

IDB	AIRFLOW	OUTDOOR AMBIENT TEMPERATURE																																																																																																		
		65°F						75°F						85°F						95°F						105°F						115°F																																																																				
		59	63	67	71	75	79	59	63	67	71	75	79	59	63	67	71	75	79	59	63	67	71	75	79	59	63	67	71	75	79	59	63	67	71	75	79																																																															
1125	MBh	28.4	29.5	32.3	-	27.8	28.8	31.5	-	27.1	28.1	30.8	-	26.4	27.4	30.0	-	25.1	26.0	28.5	-	23.3	24.1	26.4	-	S/T	0.77	0.64	0.45	-	0.80	0.67	0.46	-	0.82	0.68	0.47	-	0.85	0.71	0.49	-	0.88	0.73	0.51	-	0.88	0.74	0.51	-	ΔT	18	15	12	-	18	16	12	-	18	16	12	-	18	16	12	-	18	16	12	-	17	15	11	-																									
1000	kW	1.88	1.92	1.99	-	2.03	2.07	2.14	-	2.16	2.21	2.28	-	2.27	2.32	2.40	-	2.37	2.42	2.50	-	2.45	2.51	2.59	-	Amps	8.1	8.2	8.5	-	8.6	8.8	9.1	-	9.3	9.5	9.8	-	9.9	10.1	10.4	-	10.5	10.7	11.0	-	11.0	11.3	11.6	-	Hi PR	229	246	260	-	257	276	292	-	292	314	332	-	333	358	378	-	374	403	425	-	414	445	470	-	Lo PR	109	116	127	-	116	123	134	-	120	128	139	-	126	134	146	-	132	141	154	-	137	145	159	-
875	MBh	27.6	28.6	31.3	-	26.9	27.9	30.6	-	26.3	27.3	29.9	-	25.7	26.6	29.1	-	24.4	25.3	27.7	-	22.6	23.4	25.6	-	S/T	0.73	0.61	0.43	-	0.76	0.64	0.44	-	0.78	0.65	0.45	-	0.81	0.67	0.47	-	0.84	0.70	0.48	-	0.84	0.70	0.49	-	ΔT	19	16	12	-	19	16	12	-	19	16	12	-	19	16	12	-	19	16	12	-	18	15	12	-																									
70	kW	1.87	1.91	1.97	-	2.01	2.06	2.12	-	2.14	2.19	2.26	-	2.25	2.30	2.38	-	2.35	2.40	2.48	-	2.43	2.49	2.57	-	Amps	8.0	8.2	8.4	-	8.6	8.7	9.0	-	9.2	9.4	9.7	-	9.8	10.0	10.3	-	10.4	10.6	10.9	-	10.9	11.2	11.5	-	Hi PR	227	244	258	-	254	274	289	-	289	311	329	-	329	355	374	-	371	399	421	-	409	441	465	-	Lo PR	108	115	126	-	114	122	133	-	119	126	138	-	125	133	145	-	131	139	152	-	135	144	157	-
875	MBh	25.5	26.4	28.9	-	24.9	25.8	28.2	-	24.3	25.2	27.6	-	23.7	24.6	26.9	-	22.5	23.3	25.6	-	20.8	21.6	23.7	-	S/T	0.71	0.59	0.41	-	0.73	0.61	0.42	-	0.75	0.63	0.44	-	0.78	0.65	0.45	-	0.81	0.67	0.47	-	0.81	0.68	0.47	-	ΔT	19	16	12	-	19	17	13	-	19	17	13	-	19	17	13	-	19	17	13	-	18	15	12	-																									
75	kW	1.82	1.86	1.92	-	1.96	2.01	2.07	-	2.09	2.13	2.20	-	2.20	2.25	2.32	-	2.29	2.34	2.42	-	2.37	2.42	2.50	-	Amps	7.8	8.0	8.2	-	8.4	8.5	8.8	-	9.0	9.2	9.5	-	9.6	9.8	10.1	-	10.1	10.3	10.7	-	10.7	10.9	11.2	-	Hi PR	220	237	250	-	247	265	280	-	281	302	319	-	320	344	363	-	359	387	409	-	397	427	451	-	Lo PR	105	112	122	-	111	118	129	-	115	123	134	-	121	129	141	-	127	135	147	-	131	140	153	-

1125	MBh	28.9	29.8	32.2	34.6	28.2	29.1	31.5	33.8	27.6	28.4	30.7	33.0	26.9	27.7	30.0	32.2	25.5	26.3	28.5	30.5	23.7	24.4	26.4	28.3	S/T	0.88	0.78	0.59	0.38	0.91	0.81	0.61	0.40	0.93	0.83	0.63	0.41	0.96	0.86	0.65	0.42	1.00	0.89	0.67	0.43	1.00	0.90	0.68	0.44	ΔT	21	19	16	11	21	19	16	11	21	19	16	11	21	19	16	11	21	19	16	11	19	18	15	10																									
1000	kW	1.90	1.94	2.00	2.07	2.05	2.09	2.16	2.23	2.18	2.22	2.30	2.37	2.29	2.34	2.42	2.50	2.39	2.44	2.52	2.61	2.47	2.53	2.61	2.70	Amps	8.1	8.3	8.5	8.8	8.7	8.9	9.2	9.5	9.4	9.6	9.9	10.2	10.0	10.2	10.5	10.9	10.6	10.8	11.1	11.5	11.1	11.4	11.7	12.2	Hi PR	231	249	263	274	259	279	295	308	295	318	335	350	336	362	382	398	378	407	430	448	418	450	475	495	Lo PR	110	118	128	137	117	124	136	144	121	129	141	150	127	136	148	158	134	142	155	165	138	147	160	171
875	MBh	28.1	28.9	31.3	33.6	27.4	28.2	30.5	32.8	26.8	27.5	29.8	32.0	26.1	26.9	29.1	31.2	24.8	25.5	27.6	29.7	23.0	23.6	25.6	27.5	S/T	0.84	0.75	0.57	0.36	0.87	0.77	0.59	0.38	0.89	0.79	0.60	0.39	0.92	0.82	0.62	0.40	0.95	0.85	0.64	0.41	0.96	0.86	0.65	0.42	ΔT	22	20	16	11	22	20	16	11	22	20	16	11	22	20	16	11	22	20	16	11	20	19	15	11																									
75	kW	1.88	1.92	1.99	2.05	2.03	2.07	2.14	2.21	2.16	2.21	2.28	2.35	2.27	2.32	2.40	2.48	2.37	2.42	2.50	2.59	2.45	2.51	2.59	2.68	Amps	8.1	8.2	8.5	8.7	8.6	8.8	9.1	9.4	9.3	9.5	9.8	10.1	9.9	10.1	10.4	10.8	10.5	10.7	11.0	11.4	11.0	11.3	11.6	12.0	Hi PR	229	246	260	271	257	276	292	305	292	314	332	346	333	358	378	394	374	403	425	444	414	445	470	490	Lo PR	109	116	127	135	116	123	134	143	120	128	139	149	126	134	147	156	132	141	154	164	137	145	159	169
875	MBh	25.9	26.7	28.9	31.0	25.3	26.0	28.2	30.3	24.7	25.4	27.5	29.5	24.1	24.8	26.8	28.8	22.9	23.6	25.5	27.4	21.2	21.8	23.6	25.4	S/T	0.81	0.72	0.55	0.35	0.83	0.75	0.56	0.36	0.86	0.77	0.58	0.37	0.88	0.79	0.60	0.38	0.92	0.82	0.62	0.40	0.92	0.83	0.63	0.40	ΔT	22	20	17	11	22	20	17	12	22	20	17	12	22	21	17	12	22	20	17	11	21	19	16	11																									
75	kW	1.84	1.88	1.94	2.00	1.98	2.02	2.09	2.16	2.11	2.15	2.22	2.30	2.22	2.26	2.34	2.42	2.31	2.36	2.44	2.52	2.39	2.44	2.53	2.61	Amps	7.9	8.0	8.3	8.5	8.4	8.6	8.9	9.2	9.1	9.3	9.5	9.9	9.6	9.8	10.1	10.5	10.2	10.4	10.7	11.1	10.8	11.0	11.3	11.7	Hi PR	222	239	252	263	249	268	283	295	283	305	322	336	323	347	367	383	363	391	413	430	401	432	456	476	Lo PR	106	113	123	131	112	119	130	139	116	124	135	144	122	130	142	151	128	136	149	159	133	141	154	164

IDB: Entering Indoor Dry Bulb Temperature
High & low pressures are measured at the liquid & suction access fittings.
Shaded area reflects ACCA (ITVA) conditions
kW = Total system power
Amps = outdoor unit amps (comp.+ fans)

EXPANDED COOLING DATA — GPH1530M41* (CONT.)

IDB	AIRFLOW	OUTDOOR AMBIENT TEMPERATURE												115°F													
		65°F				75°F				85°F					95°F				105°F								
		59	63	67	71	59	63	67	71	59	63	67	71		59	63	67	71	59	63	67	71					
80	1125	MBh	29.4	30.1	32.1	34.3	28.7	29.4	31.4	33.5	28.0	28.7	30.6	32.7	27.4	28.0	29.9	31.9	26.0	26.6	28.4	30.3	24.1	24.6	26.3	28.1	
		S/T	0.96	0.90	0.73	0.55	1.00	0.93	0.76	0.57	1.00	0.96	0.78	0.58	1.00	1.00	0.80	0.60	1.00	1.00	0.83	0.62	1.00	1.00	0.84	0.63	
		ΔT	23	22	19	15	23	22	19	16	22	23	20	16	22	23	20	16	21	22	19	15	20	20	18	14	
	1000	kW	1.91	1.96	2.02	2.08	2.06	2.11	2.18	2.25	2.19	2.24	2.32	2.39	2.31	2.36	2.44	2.52	2.41	2.46	2.55	2.63	2.49	2.55	2.64	2.73	
		Amps	8.2	8.4	8.6	8.9	8.8	9.0	9.2	9.5	9.5	9.7	10.0	10.3	10.0	10.3	10.6	11.0	10.6	10.9	11.2	11.6	11.2	11.5	11.8	12.3	
		Hi PR	234	251	265	277	262	282	298	311	298	321	339	353	340	365	386	402	382	411	434	453	422	454	480	500	
	875	Lo PR	112	119	130	138	118	125	137	146	123	130	142	152	129	137	149	159	135	143	157	167	140	148	162	173	
		MBh	28.6	29.2	31.2	33.3	27.9	28.5	30.5	32.6	27.2	27.8	29.7	31.8	26.6	27.1	29.0	31.0	25.2	25.8	27.6	29.5	23.4	23.9	25.5	27.3	
		S/T	0.92	0.86	0.70	0.52	0.95	0.89	0.72	0.54	0.97	0.91	0.74	0.56	1.00	0.94	0.77	0.57	1.00	0.98	0.80	0.60	1.00	0.99	0.80	0.60	
	85	1125	ΔT	24	23	20	16	24	23	20	16	24	23	20	16	24	24	20	16	24	24	21	16	21	22	19	15
			kW	1.90	1.94	2.00	2.07	2.05	2.09	2.16	2.23	2.18	2.22	2.30	2.37	2.29	2.34	2.42	2.50	2.39	2.44	2.52	2.61	2.47	2.53	2.61	2.70
			Amps	8.1	8.3	8.5	8.8	8.7	8.9	9.2	9.5	9.4	9.6	9.9	10.2	10.0	10.2	10.5	10.9	10.6	10.8	11.1	11.5	11.1	11.4	11.7	12.2
1000		Hi PR	231	249	263	274	260	279	295	308	295	318	335	350	336	362	382	398	378	407	430	448	418	450	475	495	
		Lo PR	110	118	128	137	117	124	136	144	121	129	141	150	127	136	148	158	134	142	155	165	138	147	160	171	
		MBh	26.4	26.9	28.8	30.8	25.7	26.3	28.1	30.0	25.1	25.7	27.4	29.3	24.5	25.1	26.8	28.6	23.3	23.8	25.4	27.2	21.6	22.0	23.6	25.2	
875		S/T	0.88	0.83	0.67	0.50	0.92	0.86	0.70	0.52	0.94	0.88	0.72	0.54	0.97	0.91	0.74	0.55	1.01	0.94	0.77	0.57	1.01	0.95	0.77	0.58	
		ΔT	24	23	20	16	25	24	21	16	25	24	21	17	25	24	21	17	25	24	21	16	23	22	19	15	
		kW	1.85	1.89	1.95	2.02	2.00	2.04	2.11	2.17	2.12	2.17	2.24	2.31	2.23	2.28	2.36	2.44	2.33	2.38	2.46	2.54	2.41	2.46	2.55	2.63	
85		1125	Amps	7.9	8.1	8.3	8.6	8.5	8.7	8.9	9.2	9.1	9.3	9.6	10.0	9.7	9.9	10.2	10.6	10.3	10.5	10.8	11.2	10.8	11.1	11.4	11.8
			Hi PR	224	241	255	266	252	271	286	298	286	308	325	339	326	351	371	386	367	395	417	435	405	436	461	480
			Lo PR	107	114	124	133	113	120	132	140	118	125	137	146	124	132	144	153	130	138	150	160	134	143	156	166
	1000	MBh	29.9	30.5	31.9	34.1	29.2	29.8	31.2	33.3	28.5	29.1	30.5	32.5	27.8	28.4	29.7	31.7	26.4	27.0	28.2	30.1	24.5	25.0	26.2	27.9	
		S/T	1.00	0.97	0.88	0.71	1.00	1.00	0.91	0.74	1.00	1.00	0.93	0.76	1.00	1.00	0.96	0.78	1.00	1.00	0.90	0.81	1.00	1.00	1.00	0.82	
		ΔT	24	24	23	20	24	24	23	20	23	24	23	20	23	23	23	20	22	22	23	20	20	20	21	19	
	875	kW	1.93	1.97	2.03	2.10	2.08	2.13	2.19	2.27	2.21	2.26	2.34	2.41	2.33	2.38	2.46	2.54	2.43	2.48	2.57	2.65	2.52	2.57	2.66	2.75	
		Amps	8.2	8.4	8.7	9.0	8.8	9.0	9.3	9.6	9.5	9.7	10.0	10.4	10.1	10.4	10.7	11.1	10.7	11.0	11.3	11.7	11.3	11.6	11.9	12.4	
		Hi PR	236	254	268	280	265	285	301	314	301	324	342	357	343	369	390	406	386	415	438	457	426	459	484	505	
	1000	Lo PR	113	120	131	139	119	127	138	147	124	132	144	153	130	138	151	161	136	145	158	169	141	150	164	174	
		MBh	29.1	29.6	31.0	33.1	28.4	28.9	30.3	32.3	27.7	28.2	29.6	31.6	27.0	27.6	28.9	30.8	25.7	26.2	27.4	29.2	23.8	24.2	25.4	27.1	
		S/T	0.96	0.93	0.84	0.68	1.00	0.96	0.87	0.70	1.00	0.98	0.89	0.72	1.00	1.00	0.92	0.74	1.00	1.00	0.95	0.77	1.00	1.00	0.96	0.78	
875	ΔT	26	25	24	21	26	26	24	21	25	26	24	21	25	25	24	21	24	24	24	21	22	22	22	19		
	kW	1.91	1.96	2.02	2.08	2.06	2.11	2.18	2.25	2.19	2.24	2.32	2.39	2.31	2.36	2.44	2.52	2.41	2.46	2.55	2.63	2.49	2.55	2.64	2.73		
	Amps	8.2	8.4	8.6	8.9	8.8	9.0	9.2	9.5	9.5	9.7	10.0	10.3	10.0	10.3	10.6	11.0	10.6	10.9	11.2	11.6	11.2	11.5	11.8	12.3		
1000	Hi PR	234	251	265	277	262	282	298	311	298	321	339	353	340	365	386	402	382	411	434	453	422	454	480	500		
	Lo PR	112	119	130	138	118	125	137	146	123	130	142	152	129	137	149	159	135	143	157	167	140	148	162	173		
	MBh	26.8	27.3	28.6	30.5	26.2	26.7	28.0	29.8	25.6	26.1	27.3	29.1	24.9	25.4	26.6	28.4	23.7	24.2	25.3	27.0	22.0	22.4	23.4	25.0		
875	S/T	0.93	0.89	0.81	0.65	0.96	0.93	0.84	0.68	0.98	0.95	0.86	0.70	1.00	0.98	0.88	0.72	1.00	1.00	0.92	0.74	1.00	1.00	0.93	0.75		
	ΔT	26	26	24	21	26	26	25	21	26	26	25	21	26	26	25	21	25	25	24	21	23	24	23	20		
	kW	1.87	1.91	1.97	2.03	2.01	2.06	2.12	2.19	2.14	2.19	2.26	2.33	2.25	2.30	2.38	2.46	2.35	2.40	2.48	2.56	2.43	2.49	2.57	2.66		
1000	Amps	8.0	8.2	8.4	8.7	8.6	8.7	9.0	9.3	9.2	9.4	9.7	10.0	9.8	10.0	10.3	10.7	10.4	10.6	10.9	11.3	10.9	11.2	11.5	11.9		
	Hi PR	227	244	257	269	254	274	289	301	289	311	329	343	329	354	374	390	371	399	421	439	409	441	465	485		
	Lo PR	108	115	126	134	114	122	133	141	119	126	138	147	125	133	145	154	131	139	152	162	135	144	157	167		

IDB: Entering Indoor Dry Bulb Temperature
 High & low pressures are measured at the liquid & suction access fittings.
 Shaded area reflects AHRI (TVA) conditions
 kW = Total system power
 Amps = outdoor unit amps (comp.+ fans)

EXPANDED COOLING DATA — GPH1536M41*

IDB	OUTDOOR AMBIENT TEMPERATURE																													
	65°F					75°F					85°F					95°F					105°F					115°F				
	59	63	67	71	75	59	63	67	71	75	59	63	67	71	75	59	63	67	71	75	59	63	67	71	75	59	63	67	71	75
	ENTERING INDOOR WET BULB TEMPERATURE																													
	AIRFLOW	59	63	67	71	59	63	67	71	59	63	67	71	59	63	67	71	59	63	67	71	59	63	67	71	59	63	67	71	
1350	MBh	34.6	35.9	39.3	-	33.8	35.1	38.4	-	33.0	34.2	37.5	-	32.2	33.4	36.6	-	30.6	31.7	34.8	-	28.4	29.4	32.2	-					
	S/T	0.76	0.64	0.44	-	0.79	0.66	0.46	-	0.81	0.68	0.47	-	0.84	0.70	0.48	-	0.87	0.73	0.50	-	0.88	0.73	0.51	-					
	ΔT	18	16	12	-	18	16	12	-	18	16	12	-	18	16	12	-	18	16	12	-	17	15	11	-					
1200	kW	2.26	2.31	2.38	-	2.44	2.49	2.57	-	2.59	2.65	2.73	-	2.72	2.78	2.88	-	2.84	2.90	3.00	-	2.94	3.00	3.10	-					
	Amps	10.8	11.0	11.3	-	11.5	11.7	12.0	-	12.3	12.5	12.9	-	13.0	13.2	13.6	-	13.7	13.9	14.3	-	14.3	14.6	15.0	-					
	Hi PR	228	245	259	-	256	275	290	-	291	313	330	-	331	356	376	-	372	401	423	-	411	443	468	-					
70	Lo PR	107	114	125	-	114	121	132	-	118	126	137	-	124	132	144	-	130	138	151	-	134	143	156	-					
	MBh	33.6	34.9	38.2	-	32.9	34.1	37.3	-	32.1	33.2	36.4	-	31.3	32.4	35.5	-	29.7	30.8	33.8	-	27.5	28.5	31.3	-					
	S/T	0.73	0.61	0.42	-	0.75	0.63	0.44	-	0.77	0.65	0.45	-	0.80	0.67	0.46	-	0.83	0.69	0.48	-	0.84	0.70	0.48	-					
1050	ΔT	19	16	12	-	19	16	12	-	19	16	12	-	19	17	13	-	19	16	12	-	18	15	12	-					
	kW	2.25	2.29	2.36	-	2.42	2.47	2.55	-	2.57	2.62	2.71	-	2.70	2.76	2.85	-	2.82	2.88	2.97	-	2.91	2.98	3.08	-					
	Amps	10.7	10.9	11.2	-	11.4	11.6	11.9	-	12.2	12.4	12.8	-	12.9	13.1	13.5	-	13.5	13.8	14.2	-	14.2	14.5	14.9	-					
1050	Hi PR	225	243	256	-	253	272	287	-	288	310	327	-	328	353	372	-	369	397	419	-	407	438	463	-					
	Lo PR	106	113	124	-	112	120	131	-	117	124	136	-	123	131	142	-	129	137	149	-	133	141	154	-					
	MBh	31.1	32.2	35.3	-	30.3	31.4	34.4	-	29.6	30.7	33.6	-	28.9	29.9	32.8	-	27.4	28.4	31.2	-	25.4	26.3	28.9	-					
1050	S/T	0.70	0.59	0.41	-	0.73	0.61	0.42	-	0.75	0.62	0.43	-	0.77	0.64	0.45	-	0.80	0.67	0.46	-	0.81	0.67	0.47	-					
	ΔT	19	17	13	-	19	17	13	-	19	17	13	-	19	17	13	-	19	17	13	-	18	16	12	-					
	kW	2.19	2.24	2.31	-	2.36	2.41	2.49	-	2.51	2.56	2.64	-	2.64	2.69	2.78	-	2.75	2.81	2.90	-	2.84	2.90	3.00	-					
1050	Amps	10.5	10.7	11.0	-	11.2	11.4	11.7	-	11.9	12.2	12.5	-	12.6	12.8	13.2	-	13.2	13.5	13.9	-	13.9	14.2	14.6	-					
	Hi PR	219	235	249	-	245	264	279	-	279	300	317	-	318	342	361	-	358	385	406	-	395	425	449	-					
	Lo PR	103	110	120	-	109	116	127	-	113	121	132	-	119	127	138	-	125	133	145	-	129	137	150	-					

1350	MBh	35.2	36.3	39.3	42.1	34.4	35.4	38.4	41.2	33.6	34.6	37.4	40.2	32.8	33.7	36.5	39.2	31.1	32.1	34.7	37.2	28.8	29.7	32.1	34.5
	S/T	0.87	0.78	0.59	0.38	0.90	0.80	0.61	0.39	0.92	0.82	0.62	0.40	0.95	0.85	0.64	0.41	0.99	0.88	0.67	0.43	1.00	0.89	0.67	0.43
	ΔT	21	19	16	11	21	19	16	11	21	19	16	11	21	20	16	11	21	19	16	11	20	18	15	10
1350	kW	2.28	2.33	2.40	2.48	2.46	2.51	2.59	2.67	2.61	2.67	2.75	2.85	2.75	2.81	2.90	3.00	2.86	2.93	3.02	3.13	2.96	3.03	3.13	3.24
	Amps	10.9	11.1	11.4	11.7	11.6	11.8	12.1	12.5	12.4	12.6	13.0	13.4	13.1	13.3	13.7	14.1	13.8	14.0	14.4	14.9	14.4	14.7	15.2	15.6
	Hi PR	230	248	261	273	258	278	293	306	294	316	334	348	334	360	380	396	376	405	427	446	416	447	472	493
75	Lo PR	109	115	126	134	115	122	133	142	119	127	138	147	125	133	145	155	131	140	152	162	136	144	158	168
	MBh	34.2	35.2	38.1	40.9	33.4	34.4	37.2	40.0	32.6	33.6	36.4	39.0	31.8	32.8	35.5	38.1	30.2	31.1	33.7	36.2	28.0	28.8	31.2	33.5
	S/T	0.83	0.74	0.56	0.36	0.86	0.77	0.58	0.37	0.88	0.79	0.60	0.38	0.91	0.81	0.61	0.40	0.94	0.84	0.64	0.41	0.95	0.85	0.64	0.41
1200	ΔT	22	20	16	11	22	20	17	11	22	20	17	11	22	20	17	12	22	20	16	11	20	19	15	11
	kW	2.26	2.31	2.38	2.46	2.44	2.49	2.57	2.65	2.59	2.65	2.73	2.82	2.72	2.78	2.88	2.97	2.84	2.90	3.00	3.10	2.94	3.00	3.10	3.21
	Amps	10.8	11.0	11.3	11.6	11.5	11.7	12.0	12.4	12.3	12.5	12.9	13.3	13.0	13.2	13.6	14.0	13.7	13.9	14.3	14.8	14.3	14.6	15.0	15.5
1050	Hi PR	228	245	259	270	256	275	290	303	291	313	330	345	331	356	376	392	372	401	423	441	412	443	468	488
	Lo PR	107	114	125	133	114	121	132	140	118	126	137	146	124	132	144	153	130	138	151	161	134	143	156	166
	MBh	31.6	32.5	35.2	37.8	30.8	31.8	34.4	36.9	30.1	31.0	33.6	36.0	29.4	30.2	32.7	35.1	27.9	28.7	31.1	33.4	25.8	26.6	28.8	30.9
1050	S/T	0.80	0.71	0.54	0.35	0.83	0.74	0.56	0.36	0.85	0.76	0.57	0.37	0.88	0.78	0.59	0.38	0.91	0.81	0.62	0.40	0.92	0.82	0.62	0.40
	ΔT	22	20	17	11	22	21	17	12	22	21	17	12	23	21	17	12	23	21	17	12	21	19	16	11
	kW	2.21	2.26	2.33	2.40	2.38	2.43	2.51	2.59	2.53	2.58	2.66	2.75	2.66	2.72	2.80	2.90	2.77	2.83	2.92	3.02	2.86	2.93	3.02	3.13
1050	Amps	10.6	10.8	11.1	11.4	11.2	11.5	11.8	12.1	12.0	12.2	12.6	13.0	12.7	12.9	13.3	13.7	13.3	13.6	14.0	14.4	14.0	14.3	14.7	15.2
	Hi PR	221	238	251	262	248	267	282	294	282	303	320	334	321	346	365	381	361	389	411	428	399	430	454	473
	Lo PR	104	111	121	129	110	117	128	136	114	122	133	142	120	128	140	149	126	134	146	156	130	139	151	161

IDB: Entering Indoor Dry Bulb Temperature
 High & low pressures are measured at the liquid & suction access fittings.
 Shaded area reflects ACCA (TVA) conditions
 kW = Total system power
 Amps = outdoor unit amps (comp.+ fans)

EXPANDED COOLING DATA — GPH1536M41* (CONT.)

IDB	AIRFLOW	OUTDOOR AMBIENT TEMPERATURE																								
		65°F					75°F					85°F														
		59	63	67	71	75	59	63	67	71	75	59	63	67	71	75										
		ENTERING INDOOR WET BULB TEMPERATURE																								
		59	63	67	71	75	59	63	67	71	75	59	63	67	71	75										
	1350	MBh	35.9	36.6	39.2	41.9	35.0	35.8	38.2	40.9	34.2	34.9	37.3	39.9	33.4	34.1	36.4	38.9	31.7	32.4	34.6	37.0	29.4	30.0	32.1	34.3
		S/T	0.95	0.89	0.73	0.54	1.00	0.93	0.75	0.56	1.00	0.95	0.77	0.58	1.00	1.00	0.80	0.60	1.00	1.00	0.83	0.62	1.00	1.00	0.83	0.62
		ΔT	23	22	19	15	24	23	20	16	23	23	20	16	23	23	20	16	22	22	19	16	20	20	18	15
		kW	2.30	2.35	2.42	2.50	2.48	2.53	2.61	2.70	2.63	2.69	2.78	2.87	2.77	2.83	2.92	3.02	2.89	2.95	3.05	3.15	2.99	3.05	3.16	3.26
		Amps	11.0	11.2	11.5	11.8	11.7	11.9	12.2	12.6	12.5	12.7	13.1	13.5	13.2	13.4	13.8	14.2	13.9	14.2	14.5	15.0	14.6	14.9	15.3	15.8
		Hi PR	232	250	264	275	261	281	296	309	297	319	337	351	338	363	384	400	380	409	432	450	420	452	477	498
		Lo PR	110	117	127	136	116	123	135	143	120	128	140	149	126	135	147	156	133	141	154	164	137	146	159	170
		MBh	34.8	35.6	38.0	40.6	34.0	34.8	37.1	39.7	33.2	33.9	36.2	38.7	32.4	33.1	35.4	37.8	30.8	31.4	33.6	35.9	28.5	29.1	31.1	33.3
		S/T	0.91	0.85	0.69	0.52	0.94	0.88	0.72	0.54	0.96	0.90	0.74	0.55	1.00	0.93	0.76	0.57	1.00	0.97	0.79	0.59	1.00	0.98	0.80	0.59
		ΔT	24	23	20	16	25	24	20	16	25	24	20	16	25	24	21	16	24	23	19	16	22	22	19	15
		kW	2.28	2.33	2.40	2.48	2.46	2.51	2.59	2.67	2.61	2.67	2.75	2.85	2.75	2.81	2.89	3.00	2.86	2.93	3.02	3.13	2.96	3.03	3.13	3.24
		Amps	10.9	11.1	11.4	11.7	11.6	11.8	12.1	12.5	12.4	12.6	13.0	13.4	13.1	13.3	13.7	14.1	13.8	14.0	14.4	14.9	14.4	14.7	15.2	15.6
		Hi PR	230	248	261	273	258	278	293	306	294	316	334	348	334	360	380	396	376	405	428	446	416	447	472	493
		Lo PR	109	115	126	134	115	122	133	142	119	127	138	147	125	133	145	155	131	140	152	162	136	144	158	168
		MBh	32.1	32.8	35.1	37.5	31.4	32.1	34.3	36.6	30.6	31.3	33.5	35.8	29.9	30.5	32.6	34.9	28.4	29.0	31.0	33.1	26.3	26.9	28.7	30.7
		S/T	0.88	0.82	0.67	0.50	0.91	0.85	0.69	0.52	0.93	0.87	0.71	0.53	0.96	0.90	0.73	0.55	1.00	0.93	0.76	0.57	1.00	0.94	0.77	0.57
		ΔT	25	24	21	16	25	24	21	17	25	24	21	17	25	24	21	17	25	24	21	16	23	22	19	15
		kW	2.23	2.27	2.35	2.42	2.40	2.45	2.53	2.61	2.55	2.60	2.69	2.77	2.68	2.74	2.83	2.92	2.79	2.85	2.95	3.05	2.89	2.95	3.05	3.15
		Amps	10.7	10.9	11.1	11.5	11.3	11.5	11.8	12.2	12.1	12.3	12.7	13.1	12.8	13.0	13.4	13.8	13.4	13.7	14.1	14.5	14.1	14.4	14.8	15.3
		Hi PR	223	240	254	265	250	269	285	297	285	306	324	338	324	349	369	384	365	393	415	433	403	434	458	478
		Lo PR	105	112	122	130	111	118	129	138	116	123	134	143	121	129	141	150	127	135	148	157	132	140	153	163

		MBh	36.5	37.2	39.0	41.6	35.6	36.3	38.1	40.6	34.8	35.5	37.1	39.6	33.9	34.6	36.2	38.7	32.2	32.9	34.4	36.7	29.9	30.4	31.9	34.0
		S/T	1.00	0.96	0.87	0.70	1.00	1.00	0.90	0.73	1.00	1.00	0.92	0.75	1.00	1.00	0.95	0.77	1.00	1.00	0.99	0.80	1.00	1.00	1.00	0.81
		ΔT	25	24	23	20	24	25	23	20	24	24	23	20	23	24	24	20	22	22	19	16	20	21	22	19
		kW	2.32	2.37	2.44	2.52	2.50	2.55	2.63	2.72	2.65	2.71	2.80	2.89	2.79	2.85	2.95	3.05	2.91	2.98	3.07	3.18	3.01	3.08	3.18	3.29
		Amps	11.0	11.3	11.5	11.9	11.7	12.0	12.3	12.7	12.6	12.8	13.2	13.6	13.3	13.5	13.9	14.4	14.0	14.3	14.7	15.1	14.7	15.0	15.4	15.9
		Hi PR	235	253	267	278	263	283	299	312	300	322	340	355	341	367	388	404	384	413	436	455	424	456	482	503
		Lo PR	111	118	129	137	117	124	136	145	122	129	141	150	128	136	148	158	134	142	155	166	138	147	161	171
		MBh	35.4	36.1	37.8	40.4	34.6	35.3	36.9	39.4	33.8	34.4	36.1	38.5	33.0	33.6	35.2	37.5	31.3	31.9	33.4	35.7	29.0	29.6	31.0	33.0
		S/T	0.95	0.92	0.83	0.67	0.99	0.95	0.86	0.70	1.00	0.98	0.88	0.71	1.00	1.00	0.91	0.74	1.00	1.00	0.94	0.77	1.00	1.00	0.95	0.77
		ΔT	26	25	24	21	26	26	24	21	26	26	24	21	25	26	25	21	24	24	24	21	22	23	23	20
		kW	2.30	2.35	2.42	2.50	2.48	2.53	2.61	2.70	2.63	2.69	2.78	2.87	2.77	2.83	2.92	3.02	2.89	2.95	3.05	3.15	2.99	3.05	3.16	3.26
		Amps	11.0	11.2	11.5	11.8	11.7	11.9	12.2	12.6	12.5	12.7	13.1	13.5	13.2	13.4	13.8	14.2	13.9	14.2	14.5	15.0	14.6	14.9	15.3	15.8
		Hi PR	232	250	264	275	261	281	296	309	297	319	337	351	338	363	384	400	380	409	432	450	420	452	477	498
		Lo PR	110	117	127	136	116	123	135	143	120	128	140	149	126	135	147	156	133	141	154	164	137	146	159	170
		MBh	32.7	33.3	34.9	37.2	31.9	32.6	34.1	36.4	31.2	31.8	33.3	35.5	30.4	31.0	32.5	34.6	28.9	29.5	30.9	32.9	26.8	27.3	28.6	30.5
		S/T	0.92	0.89	0.80	0.65	0.95	0.92	0.83	0.67	0.98	0.94	0.85	0.69	1.00	0.97	0.88	0.71	1.00	1.00	0.91	0.74	1.00	1.00	0.92	0.74
		ΔT	26	26	24	21	27	26	25	21	27	26	25	21	27	26	25	22	25	26	25	21	23	24	23	20
		kW	2.25	2.29	2.36	2.44	2.42	2.47	2.55	2.63	2.57	2.62	2.71	2.80	2.70	2.76	2.85	2.95	2.81	2.88	2.97	3.07	2.91	2.98	3.08	3.18
		Amps	10.7	10.9	11.2	11.5	11.4	11.6	11.9	12.3	12.2	12.4	12.8	13.2	12.9	13.1	13.5	13.9	13.5	13.8	14.2	14.7	14.2	14.5	14.9	15.4
		Hi PR	225	243	256	267	253	272	287	300	288	310	327	341	328	353	372	388	369	397	419	437	407	438	463	483
		Lo PR	106	113	124	132	112	120	130	139	117	124	136	144	123	130	142	152	129	137	149	159	133	141	154	164

Shaded area reflects AHRI (TVA) conditions
 kW = Total system power
 Amps = outdoor unit amps (comp.+ fans)

High & low pressures are measured at the liquid & suction access fittings.

IDB: Entering Indoor Dry Bulb Temperature
 High & low pressures are measured at the liquid & suction access fittings.

EXPANDED COOLING DATA — GPH1542M41* — LOW STAGE

IDB	AIRFLOW	OUTDOOR AMBIENT TEMPERATURE														ENTERING INDOOR WET BULB TEMPERATURE													
		65°F				75°F				85°F				95°F				105°F				115°F							
		59	63	67	71	59	63	67	71	59	63	67	71	59	63	67	71	59	63	67	71	59	63	67	71				
70	MBh	26.9	27.9	30.6	-	26.3	27.3	29.9	-	25.7	26.6	29.2	-	25.1	26.0	28.5	-	23.8	24.7	27.0	-	22.1	22.9	25.1	-				
	S/T	0.70	0.59	0.41	-	0.73	0.61	0.42	-	0.75	0.62	0.43	-	0.77	0.65	0.45	-	0.80	0.67	0.46	-	0.81	0.68	0.47	-				
	ΔT	18	16	12	-	18	16	12	-	19	16	12	-	19	16	12	-	18	16	12	-	17	15	11	-				
	kW	1.80	1.84	1.90	-	1.94	1.99	2.06	-	2.07	2.12	2.19	-	2.19	2.24	2.31	-	2.28	2.33	2.41	-	2.36	2.42	2.50	-				
	Amps	7.7	7.9	8.1	-	8.3	8.5	8.7	-	9.0	9.2	9.5	-	9.6	9.8	10.1	-	10.1	10.4	10.7	-	10.7	11.0	11.3	-				
	Hi PR	218	235	248	-	245	263	278	-	278	300	316	-	317	341	360	-	357	384	405	-	394	424	448	-				
	Lo PR	107	114	124	-	113	120	131	-	118	125	137	-	124	131	144	-	130	138	150	-	134	143	156	-				
	MBh	26.2	27.1	29.7	-	25.6	26.5	29.0	-	24.9	25.9	28.3	-	24.3	25.2	27.6	-	23.1	24.0	26.3	-	21.4	22.2	24.3	-				
	S/T	0.67	0.56	0.39	-	0.70	0.58	0.40	-	0.71	0.60	0.41	-	0.74	0.62	0.43	-	0.76	0.64	0.44	-	0.77	0.64	0.45	-				
	ΔT	19	16	12	-	19	17	13	-	19	17	13	-	19	17	13	-	19	17	13	-	18	15	12	-				
	kW	1.79	1.82	1.88	-	1.93	1.97	2.04	-	2.06	2.10	2.17	-	2.17	2.22	2.29	-	2.26	2.31	2.39	-	2.34	2.40	2.48	-				
	Amps	7.7	7.8	8.1	-	8.2	8.4	8.7	-	8.9	9.1	9.4	-	9.5	9.7	10.0	-	10.0	10.3	10.6	-	10.6	10.9	11.2	-				
Hi PR	216	232	245	-	242	261	275	-	276	297	313	-	314	338	357	-	353	380	401	-	390	420	443	-					
Lo PR	106	113	123	-	112	119	130	-	116	124	135	-	122	130	142	-	128	136	149	-	133	141	154	-					
MBh	24.1	25.0	27.4	-	23.6	24.4	26.8	-	23.0	23.9	26.1	-	22.5	23.3	25.5	-	21.3	22.1	24.2	-	19.8	20.5	22.4	-					
S/T	0.65	0.54	0.37	-	0.67	0.56	0.39	-	0.69	0.57	0.40	-	0.71	0.59	0.41	-	0.74	0.62	0.43	-	0.74	0.62	0.43	-					
ΔT	19	17	13	-	20	17	13	-	20	17	13	-	20	17	13	-	19	17	13	-	18	16	12	-					
kW	1.74	1.78	1.84	-	1.88	1.92	1.99	-	2.00	2.05	2.12	-	2.11	2.16	2.23	-	2.20	2.25	2.33	-	2.28	2.34	2.42	-					
Amps	7.5	7.6	7.9	-	8.0	8.2	8.5	-	8.7	8.9	9.1	-	9.2	9.4	9.7	-	9.8	10.0	10.3	-	10.3	10.6	10.9	-					
Hi PR	209	225	238	-	235	253	267	-	267	288	304	-	304	328	346	-	343	369	389	-	378	407	430	-					
Lo PR	103	109	120	-	109	116	126	-	113	120	131	-	119	126	138	-	124	132	144	-	129	137	149	-					

75	MBh	27.4	28.2	30.5	32.8	26.8	27.6	29.8	32.0	26.1	26.9	29.1	31.3	25.5	26.2	28.4	30.5	24.2	24.9	27.0	29.0	22.4	23.1	25.0	26.8
	S/T	0.80	0.72	0.54	0.35	0.83	0.74	0.56	0.36	0.85	0.76	0.58	0.37	0.88	0.79	0.59	0.38	0.91	0.82	0.62	0.40	0.92	0.82	0.62	0.40
	ΔT	21	19	16	11	21	20	16	11	21	20	16	11	22	20	16	11	21	20	16	11	20	18	15	10
	kW	1.82	1.86	1.92	1.98	1.96	2.01	2.07	2.14	2.09	2.14	2.21	2.29	2.20	2.26	2.33	2.41	2.30	2.36	2.44	2.52	2.39	2.44	2.53	2.61
	Amps	7.8	8.0	8.2	8.5	8.4	8.6	8.8	9.1	9.0	9.3	9.5	9.9	9.6	9.9	10.2	10.5	10.2	10.5	10.8	11.2	10.8	11.1	11.4	11.8
	Hi PR	220	237	250	261	247	266	281	293	281	303	320	333	320	345	364	380	360	388	409	427	398	428	452	472
	Lo PR	108	115	126	134	114	122	133	141	119	126	138	147	125	133	145	154	131	139	152	162	135	144	157	167
	MBh	26.6	27.4	29.7	31.8	26.0	26.8	29.0	31.1	25.4	26.1	28.3	30.3	24.8	25.5	27.6	29.6	23.5	24.2	26.2	28.1	21.8	22.4	24.3	26.1
	S/T	0.76	0.68	0.52	0.33	0.79	0.71	0.54	0.34	0.81	0.73	0.55	0.35	0.84	0.75	0.57	0.36	0.87	0.78	0.59	0.38	0.88	0.78	0.59	0.38
	ΔT	22	20	17	11	22	20	17	12	22	20	17	12	22	21	17	12	22	20	17	12	21	19	16	11
	kW	1.80	1.84	1.90	1.96	1.95	1.99	2.06	2.13	2.07	2.12	2.19	2.27	2.19	2.24	2.31	2.39	2.28	2.33	2.42	2.50	2.36	2.42	2.50	2.59
	Amps	7.7	7.9	8.1	8.4	8.3	8.5	8.8	9.1	9.0	9.2	9.5	9.8	9.6	9.8	10.1	10.4	10.1	10.4	10.7	11.1	10.7	11.0	11.3	11.7
Hi PR	218	235	248	259	245	263	278	290	278	300	316	330	317	341	360	376	357	384	405	423	394	424	448	467	
Lo PR	107	114	124	133	113	120	131	140	118	125	137	146	124	131	144	153	130	138	150	160	134	143	156	166	
MBh	24.6	25.3	27.4	29.4	24.0	24.7	26.7	28.7	23.4	24.1	26.1	28.0	22.8	23.5	25.5	27.3	21.7	22.3	24.2	26.0	20.1	20.7	22.4	24.0	
S/T	0.74	0.66	0.50	0.32	0.76	0.68	0.52	0.33	0.78	0.70	0.53	0.34	0.81	0.72	0.55	0.35	0.84	0.75	0.57	0.36	0.84	0.76	0.57	0.37	
ΔT	22	21	17	12	23	21	17	12	23	21	17	12	23	21	17	12	23	21	17	12	21	19	16	11	
kW	1.76	1.79	1.85	1.91	1.90	1.94	2.00	2.07	2.02	2.07	2.14	2.21	2.13	2.18	2.25	2.33	2.22	2.27	2.35	2.43	2.30	2.36	2.44	2.52	
Amps	7.5	7.7	7.9	8.2	8.1	8.3	8.5	8.8	8.7	8.9	9.2	9.5	9.3	9.5	9.8	10.2	9.9	10.1	10.4	10.8	10.4	10.7	11.0	11.4	
Hi PR	212	228	240	251	237	256	270	281	270	291	307	320	308	331	350	365	346	372	393	410	382	411	434	453	
Lo PR	104	111	121	129	110	117	128	136	114	121	133	141	120	128	139	148	126	134	146	155	130	138	151	161	

kW = Total system power
Amps = outdoor unit amps (comp.+ fans)

Shaded area reflects ACCA (TVA) conditions

IDB: Entering Indoor Dry Bulb Temperature
High & low pressures are measured at the liquid & suction access fittings.

EXPANDED COOLING DATA — GPH1542M41* — LOW STAGE (CONT.)

IDB	AIRFLOW	OUTDOOR AMBIENT TEMPERATURE												ENTERING INDOOR WET BULB TEMPERATURE											
		65°F				75°F				85°F				95°F				105°F				115°F			
		59	63	67	71	59	63	67	71	59	63	67	71	59	63	67	71	59	63	67	71	59	63	67	71
80	MBh	27.9	28.5	30.4	32.6	27.2	27.8	29.7	31.8	26.6	27.2	29.0	31.0	25.9	26.5	28.3	30.3	24.6	25.2	26.9	28.8	22.8	23.3	24.9	26.6
	S/T	0.88	0.82	0.67	0.50	0.91	0.85	0.69	0.52	0.93	0.87	0.71	0.53	0.96	0.90	0.74	0.55	1.00	0.94	0.76	0.57	1.00	0.95	0.77	0.57
	ΔT	24	23	20	16	24	23	20	16	24	23	20	16	24	23	20	16	24	23	20	16	22	21	18	15
	kW	1.83	1.87	1.93	2.00	1.98	2.02	2.09	2.16	2.11	2.16	2.23	2.31	2.22	2.28	2.35	2.44	2.32	2.38	2.46	2.54	2.41	2.46	2.55	2.64
	Amps	7.9	8.0	8.3	8.6	8.4	8.6	8.9	9.2	9.1	9.3	9.6	10.0	9.7	9.9	10.3	10.6	10.3	10.6	10.9	11.3	10.9	11.2	11.5	11.9
	Hi PR	223	240	253	264	250	269	284	296	284	306	323	337	324	348	368	383	364	392	414	431	402	433	457	477
	Lo PR	109	116	127	135	116	123	134	143	120	128	139	148	126	134	146	156	132	141	153	163	137	145	159	169
	MBh	27.1	27.7	29.6	31.6	26.4	27.0	28.9	30.9	25.8	26.4	28.2	30.1	25.2	25.7	27.5	29.4	23.9	24.5	26.1	27.9	22.2	22.7	24.2	25.9
	S/T	0.84	0.79	0.64	0.48	0.87	0.81	0.66	0.50	0.89	0.83	0.68	0.51	0.92	0.86	0.70	0.52	0.95	0.89	0.73	0.54	0.96	0.90	0.73	0.55
	ΔT	25	23	20	16	25	24	21	17	25	24	21	17	25	24	21	17	25	24	21	16	23	22	19	15
kW	1.82	1.86	1.92	1.98	1.96	2.01	2.07	2.14	2.09	2.14	2.21	2.29	2.21	2.26	2.33	2.41	2.30	2.36	2.44	2.52	2.39	2.44	2.53	2.61	
Amps	7.8	8.0	8.2	8.5	8.4	8.6	8.8	9.1	9.1	9.3	9.5	9.9	9.6	9.9	10.2	10.5	10.2	10.5	10.8	11.2	10.8	11.1	11.4	11.8	
Hi PR	220	237	250	261	247	266	281	293	281	303	320	333	320	345	364	380	360	388	410	427	398	428	452	472	
Lo PR	108	115	126	134	114	122	133	141	119	126	138	147	125	133	145	154	131	139	152	162	135	144	157	167	
MBh	25.0	25.5	27.3	29.2	24.4	24.9	26.7	28.5	23.8	24.4	26.0	27.8	23.3	23.8	25.4	27.1	22.1	22.6	24.1	25.8	20.5	20.9	22.3	23.9	
S/T	0.81	0.76	0.62	0.46	0.84	0.78	0.64	0.48	0.86	0.80	0.65	0.49	0.89	0.83	0.68	0.51	0.92	0.86	0.70	0.52	0.93	0.87	0.71	0.53	
ΔT	25	24	21	17	25	24	21	17	25	24	21	17	25	24	21	17	25	24	21	17	23	22	20	16	
kW	1.77	1.81	1.87	1.93	1.91	1.95	2.02	2.09	2.04	2.08	2.15	2.23	2.15	2.20	2.27	2.35	2.24	2.29	2.37	2.46	2.32	2.38	2.46	2.55	
Amps	7.6	7.8	8.0	8.3	8.2	8.3	8.6	8.9	8.8	9.0	9.3	9.6	9.4	9.6	9.9	10.3	10.0	10.2	10.5	10.9	10.5	10.8	11.1	11.5	
Hi PR	214	230	243	253	240	258	273	284	273	294	310	323	311	334	353	368	350	376	397	414	386	416	439	458	
Lo PR	105	112	122	130	111	118	129	137	115	123	134	143	121	129	141	150	127	135	147	157	131	140	152	162	

85	MBh	28.4	28.9	30.3	32.3	27.7	28.3	29.6	31.6	27.1	27.6	28.9	30.8	26.4	26.9	28.2	30.1	25.1	25.6	26.8	28.6	23.2	23.7	24.8	26.5
	S/T	0.92	0.89	0.80	0.65	0.95	0.92	0.83	0.67	0.98	0.94	0.85	0.69	1.00	0.97	0.88	0.71	1.00	1.00	0.91	0.74	1.00	1.00	0.92	0.75
	ΔT	25	25	23	20	25	25	24	20	25	25	24	20	25	25	24	21	24	25	24	20	22	23	22	19
	kW	1.85	1.89	1.95	2.02	2.00	2.04	2.11	2.18	2.13	2.18	2.25	2.33	2.24	2.30	2.37	2.46	2.34	2.40	2.48	2.57	2.43	2.48	2.57	2.66
	Amps	7.9	8.1	8.3	8.6	8.5	8.7	9.0	9.3	9.2	9.4	9.7	10.1	9.8	10.0	10.3	10.7	10.4	10.6	11.0	11.4	11.0	11.2	11.6	12.0
	Hi PR	225	242	255	266	252	271	287	299	287	309	326	340	327	352	371	387	368	396	418	436	406	437	462	481
	Lo PR	110	117	128	137	117	124	135	144	121	129	141	150	127	135	148	158	133	142	155	165	138	147	160	171
	MBh	27.6	28.1	29.4	31.4	26.9	27.4	28.7	30.7	26.3	26.8	28.0	29.9	25.6	26.1	27.4	29.2	24.3	24.8	26.0	27.7	22.6	23.0	24.1	25.7
	S/T	0.88	0.85	0.76	0.62	0.91	0.88	0.79	0.64	0.93	0.90	0.81	0.66	0.96	0.93	0.84	0.68	1.00	0.96	0.87	0.71	1.00	0.97	0.88	0.71
	ΔT	26	26	24	21	26	26	25	21	27	26	25	21	27	26	25	21	26	26	24	21	24	24	23	20
kW	1.83	1.87	1.93	2.00	1.98	2.02	2.09	2.16	2.11	2.16	2.23	2.31	2.22	2.28	2.35	2.44	2.32	2.38	2.46	2.54	2.41	2.46	2.55	2.64	
Amps	7.9	8.0	8.3	8.6	8.4	8.6	8.9	9.2	9.1	9.3	9.6	10.0	9.7	9.9	10.3	10.6	10.3	10.6	10.9	11.3	10.9	11.2	11.5	11.9	
Hi PR	223	240	253	264	250	269	284	296	284	306	323	337	324	348	368	383	364	392	414	431	402	433	457	477	
Lo PR	109	116	127	135	116	123	134	143	120	128	139	148	126	134	146	156	132	141	153	163	137	145	159	169	
MBh	25.4	25.9	27.1	29.0	24.8	25.3	26.5	28.3	24.2	24.7	25.9	27.6	23.7	24.1	25.3	26.9	22.5	22.9	24.0	25.6	20.8	21.2	22.2	23.7	
S/T	0.85	0.82	0.74	0.60	0.88	0.85	0.76	0.62	0.90	0.87	0.78	0.64	0.93	0.90	0.81	0.66	0.96	0.93	0.84	0.68	0.97	0.94	0.85	0.69	
ΔT	27	26	25	21	27	26	25	22	27	26	25	22	27	27	25	22	27	26	25	22	25	25	23	20	
kW	1.78	1.82	1.88	1.95	1.93	1.97	2.04	2.11	2.05	2.10	2.17	2.25	2.17	2.22	2.29	2.37	2.26	2.31	2.39	2.48	2.34	2.40	2.48	2.57	
Amps	7.7	7.8	8.1	8.3	8.2	8.4	8.7	9.0	8.9	9.1	9.4	9.7	9.5	9.7	10.0	10.3	10.0	10.3	10.6	11.0	10.6	10.9	11.2	11.6	
Hi PR	216	232	245	256	242	261	275	287	276	297	313	327	314	338	357	372	353	380	401	418	390	420	443	462	
Lo PR	106	113	123	131	112	119	130	139	116	124	135	144	122	130	142	151	128	136	149	159	133	141	154	164	

IDB: Entering Indoor Dry Bulb Temperature
 High & low pressures are measured at the liquid & suction access fittings.
 Shaded area reflects AHRI (TVA) conditions
 kW = Total system power
 Amps = outdoor unit amps (comp. + fans)

EXPANDED COOLING DATA — GPH1542M41* — HIGH STAGE

IDB	OUTDOOR AMBIENT TEMPERATURE																								
	65°F				75°F				85°F				95°F				105°F				115°F				
	59	63	67	71	59	63	67	71	59	63	67	71	59	63	67	71	59	63	67	71	59	63	67	71	
	ENTERING INDOOR WET BULB TEMPERATURE																								
	AIRFLOW	59	63	67	71	59	63	67	71	59	63	67	71	59	63	67	71	59	63	67	71	59	63	67	71
1405	MBh	40.2	41.6	45.6	-	39.2	40.7	44.6	-	38.3	39.7	43.5	-	37.4	38.7	42.4	-	35.5	36.8	40.3	-	32.9	34.1	37.3	-
	S/T	0.72	0.60	0.42	-	0.74	0.62	0.43	-	0.76	0.64	0.44	-	0.79	0.66	0.46	-	0.82	0.68	0.47	-	0.82	0.69	0.48	-
	ΔT	19	16	12	-	19	17	13	-	19	17	13	-	19	17	13	-	19	16	12	-	18	15	12	-
	kW	2.82	2.88	2.97	-	3.04	3.11	3.21	-	3.24	3.31	3.43	-	3.42	3.49	3.61	-	3.57	3.65	3.77	-	3.69	3.78	3.91	-
	Amps	11.8	12.1	12.4	-	12.7	13.0	13.3	-	13.7	14.0	14.4	-	14.6	14.9	15.4	-	15.4	15.8	16.3	-	16.3	16.7	17.2	-
	Hi PR	242	261	275	-	272	292	309	-	309	332	351	-	352	379	400	-	396	426	450	-	437	471	497	-
70	Lo PR	105	112	122	-	111	118	129	-	115	123	134	-	121	129	141	-	127	135	147	-	131	140	152	-
	MBh	39.0	40.4	44.3	-	38.1	39.5	43.3	-	37.2	38.5	42.2	-	36.3	37.6	41.2	-	34.5	35.7	39.1	-	31.9	33.1	36.3	-
	S/T	0.68	0.57	0.40	-	0.71	0.59	0.41	-	0.73	0.61	0.42	-	0.75	0.63	0.43	-	0.78	0.65	0.45	-	0.79	0.66	0.45	-
	ΔT	20	17	13	-	20	17	13	-	20	17	13	-	20	17	13	-	20	17	13	-	18	16	12	-
	kW	2.79	2.86	2.95	-	3.02	3.08	3.19	-	3.21	3.29	3.40	-	3.39	3.46	3.58	-	3.53	3.62	3.74	-	3.66	3.75	3.88	-
	Amps	11.7	12.0	12.3	-	12.6	12.8	13.2	-	13.6	13.9	14.3	-	14.4	14.8	15.2	-	15.3	15.7	16.2	-	16.2	16.5	17.1	-
1095	Hi PR	240	258	272	-	269	289	306	-	306	329	348	-	348	375	396	-	392	422	445	-	433	466	492	-
	Lo PR	104	111	121	-	110	117	127	-	114	121	132	-	120	127	139	-	126	134	146	-	130	138	151	-
	MBh	36.0	37.3	40.9	-	35.2	36.4	39.9	-	34.3	35.6	39.0	-	33.5	34.7	38.0	-	31.8	33.0	36.1	-	29.5	30.5	33.5	-
	S/T	0.66	0.55	0.38	-	0.68	0.57	0.40	-	0.70	0.59	0.41	-	0.72	0.60	0.42	-	0.75	0.63	0.43	-	0.76	0.63	0.44	-
	ΔT	20	17	13	-	20	17	13	-	20	17	13	-	20	18	13	-	20	17	13	-	19	16	12	-
	kW	2.72	2.78	2.88	-	2.94	3.01	3.11	-	3.13	3.20	3.31	-	3.30	3.38	3.49	-	3.44	3.52	3.64	-	3.57	3.65	3.77	-
1095	Amps	11.4	11.7	12.0	-	12.2	12.5	12.9	-	13.2	13.5	13.9	-	14.1	14.4	14.8	-	14.9	15.3	15.7	-	15.7	16.1	16.6	-
	Hi PR	233	250	264	-	261	281	296	-	297	319	337	-	338	364	384	-	380	409	432	-	420	452	477	-
	Lo PR	101	107	117	-	106	113	124	-	111	118	129	-	116	124	135	-	122	130	141	-	126	134	146	-

1405	MBh	40.9	42.1	45.5	48.9	39.9	41.1	44.5	47.7	39.0	40.1	43.4	46.6	38.0	39.1	42.4	45.5	36.1	37.2	40.2	43.2	33.4	34.4	37.3	40.0
	S/T	0.82	0.73	0.55	0.36	0.85	0.76	0.57	0.37	0.87	0.78	0.59	0.38	0.89	0.80	0.61	0.39	0.93	0.83	0.63	0.40	0.94	0.84	0.63	0.41
	ΔT	22	20	16	11	22	20	17	12	22	20	17	12	22	20	17	12	22	20	17	11	20	19	15	11
	kW	2.84	2.90	3.00	3.10	3.07	3.14	3.24	3.35	3.27	3.34	3.46	3.57	3.45	3.52	3.64	3.77	3.60	3.68	3.81	3.94	3.73	3.81	3.94	4.08
	Amps	11.9	12.2	12.5	13.0	12.8	13.1	13.5	13.9	13.8	14.1	14.6	15.1	14.7	15.0	15.5	16.1	15.6	15.9	16.4	17.0	16.5	16.8	17.4	18.0
	Hi PR	245	263	278	290	274	295	312	325	312	336	355	370	355	383	404	421	400	430	454	474	442	476	502	524
75	Lo PR	106	113	123	131	112	119	130	139	116	124	135	144	122	130	142	151	128	136	149	158	133	141	154	164
	MBh	39.7	40.8	44.2	47.4	38.7	39.9	43.2	46.3	37.8	38.9	42.2	45.2	36.9	38.0	41.1	44.1	35.1	36.1	39.1	41.9	32.5	33.4	36.2	38.8
	S/T	0.78	0.70	0.53	0.34	0.81	0.72	0.55	0.35	0.83	0.74	0.56	0.36	0.85	0.76	0.58	0.37	0.89	0.79	0.60	0.39	0.89	0.80	0.60	0.39
	ΔT	23	21	17	12	23	21	17	12	23	21	17	12	23	21	17	12	23	21	17	12	21	20	16	11
	kW	2.82	2.88	2.97	3.07	3.04	3.11	3.21	3.32	3.24	3.31	3.43	3.54	3.42	3.49	3.61	3.74	3.57	3.65	3.77	3.90	3.69	3.78	3.91	4.05
	Amps	11.8	12.1	12.4	12.8	12.7	13.0	13.4	13.8	13.7	14.0	14.4	14.9	14.6	14.9	15.4	15.9	15.4	15.8	16.3	16.9	16.3	16.7	17.2	17.8
1095	Hi PR	242	261	275	287	272	292	309	322	309	333	351	366	352	379	400	417	396	426	450	469	437	471	497	519
	Lo PR	105	112	122	130	111	118	129	137	115	123	134	143	121	129	141	150	127	135	147	157	131	140	152	162
	MBh	36.6	37.7	40.8	43.8	35.8	36.8	39.9	42.8	34.9	35.9	38.9	41.8	34.1	35.1	38.0	40.7	32.4	33.3	36.1	38.7	30.0	30.9	33.4	35.8
	S/T	0.75	0.67	0.51	0.33	0.78	0.70	0.53	0.34	0.80	0.71	0.54	0.35	0.82	0.74	0.56	0.36	0.85	0.76	0.58	0.37	0.86	0.77	0.58	0.38
	ΔT	23	21	17	12	23	21	18	12	23	22	18	12	24	22	18	12	24	22	18	12	22	20	16	11
	kW	2.75	2.81	2.90	3.00	2.97	3.03	3.13	3.24	3.16	3.23	3.34	3.45	3.33	3.40	3.52	3.64	3.47	3.55	3.67	3.80	3.60	3.68	3.81	3.94
1095	Amps	11.5	11.8	12.1	12.5	12.4	12.6	13.0	13.5	13.3	13.6	14.1	14.6	14.2	14.5	15.0	15.5	15.0	15.4	15.9	16.4	15.9	16.2	16.8	17.4
	Hi PR	235	253	267	278	264	284	300	312	300	323	341	355	341	367	388	405	384	413	436	455	424	457	482	503
	Lo PR	102	108	118	126	108	114	125	133	112	119	130	138	117	125	136	145	123	131	143	152	127	135	148	157

IDB: Entering Indoor Dry Bulb Temperature
 High & low pressures are measured at the liquid & suction access fittings.

Shaded area reflects ACCA (TVA) conditions

kW = Total system power
 Amps = outdoor unit amps (comp. + fans)

EXPANDED COOLING DATA — GPH1542M41* — HIGH STAGE (CONT.)

IDB	AIRFLOW	OUTDOOR AMBIENT TEMPERATURE												ENTERING INDOOR WET BULB TEMPERATURE											
		65°F				75°F				85°F				95°F				105°F				115°F			
		59	63	67	71	59	63	67	71	59	63	67	71	59	63	67	71	59	63	67	71	59	63	67	71
1405	MBh	41.6	42.5	45.4	48.5	40.6	41.5	44.3	47.4	39.6	40.5	43.3	46.3	38.7	39.5	42.2	45.1	36.7	37.6	40.1	42.9	34.0	34.8	37.2	39.7
	S/T	0.89	0.84	0.68	0.51	0.93	0.87	0.71	0.53	0.95	0.89	0.73	0.54	1.00	0.92	0.75	0.56	1.00	0.96	0.78	0.58	1.00	0.96	0.78	0.59
	ΔT	24	23	20	16	25	24	21	16	25	24	21	16	25	24	21	17	24	23	20	16	22	22	19	15
	kW	2.86	2.93	3.02	3.13	3.09	3.16	3.27	3.38	3.30	3.37	3.49	3.61	3.48	3.56	3.68	3.80	3.63	3.71	3.84	3.97	3.76	3.85	3.98	4.12
	Amps	12.0	12.3	12.6	13.1	12.9	13.2	13.6	14.1	13.9	14.2	14.7	15.2	14.8	15.2	15.6	16.2	15.7	16.1	16.6	17.2	16.6	17.0	17.5	18.2
	Hi PR	247	266	281	293	277	298	315	329	315	339	358	374	359	386	408	426	404	435	459	479	446	480	507	529
	Lo PR	107	114	124	132	113	120	131	140	118	125	137	145	123	131	143	153	129	138	150	160	134	142	155	166
	MBh	40.4	41.3	44.1	47.1	39.4	40.3	43.1	46.0	38.5	39.3	42.0	44.9	37.6	38.4	41.0	43.8	35.7	36.5	39.0	41.6	33.0	33.8	36.1	38.6
	S/T	0.85	0.80	0.65	0.49	0.88	0.83	0.68	0.50	0.91	0.85	0.69	0.52	0.94	0.88	0.71	0.53	0.97	0.91	0.74	0.55	0.98	0.92	0.75	0.56
	ΔT	25	24	21	17	26	25	21	17	26	25	21	17	26	25	22	17	25	24	21	17	24	23	20	16
1250	kW	2.84	2.90	3.00	3.10	3.07	3.14	3.24	3.35	3.27	3.34	3.46	3.57	3.45	3.53	3.65	3.77	3.60	3.68	3.81	3.94	3.73	3.81	3.94	4.08
	Amps	11.9	12.2	12.5	13.0	12.8	13.1	13.5	13.9	13.8	14.1	14.6	15.1	14.7	15.0	15.5	16.1	15.6	15.9	16.4	17.0	16.5	16.8	17.4	18.0
	Hi PR	245	263	278	290	274	295	312	325	312	336	355	370	356	383	404	421	400	430	455	474	442	476	502	524
	Lo PR	106	113	123	131	112	119	130	139	116	124	135	144	122	130	142	151	128	136	149	158	133	141	154	164
	MBh	37.3	38.1	40.7	43.5	36.4	37.2	39.7	42.5	35.5	36.3	38.8	41.5	34.7	35.4	37.8	40.5	32.9	33.6	36.0	38.4	30.5	31.2	33.3	35.6
	S/T	0.82	0.77	0.63	0.47	0.85	0.80	0.65	0.49	0.87	0.82	0.67	0.50	0.90	0.85	0.69	0.51	0.94	0.88	0.72	0.53	0.94	0.89	0.72	0.54
	ΔT	26	25	21	17	26	25	22	17	26	25	22	17	26	25	22	17	26	25	22	17	24	23	20	16
	kW	2.77	2.83	2.92	3.02	2.99	3.06	3.16	3.27	3.19	3.26	3.37	3.48	3.36	3.43	3.55	3.67	3.50	3.58	3.71	3.83	3.63	3.71	3.84	3.97
	Amps	11.6	11.8	12.2	12.6	12.5	12.7	13.1	13.6	13.5	13.8	14.2	14.7	14.3	14.6	15.1	15.6	15.2	15.5	16.0	16.6	16.0	16.4	16.9	17.5
	Hi PR	237	255	270	281	266	286	303	316	303	326	344	359	345	371	392	409	388	417	441	460	429	461	487	508
Lo PR	103	109	119	127	109	116	126	134	113	120	131	140	119	126	138	147	124	132	144	154	129	137	149	159	

1405	MBh	42.3	43.1	45.2	48.2	41.3	42.1	44.1	47.1	40.3	41.1	43.1	45.9	39.4	40.1	42.0	44.8	37.4	38.1	39.9	42.6	34.6	35.3	37.0	39.4
	S/T	0.94	0.91	0.82	0.66	0.97	0.94	0.85	0.69	1.00	0.96	0.87	0.70	1.00	0.99	0.90	0.73	1.00	1.00	0.93	0.75	1.00	1.00	0.94	0.76
	ΔT	26	26	24	21	26	26	24	21	26	26	24	21	26	26	25	21	24	25	24	21	23	23	23	20
	kW	2.89	2.95	3.05	3.15	3.12	3.19	3.30	3.41	3.33	3.40	3.52	3.64	3.51	3.59	3.71	3.84	3.66	3.74	3.87	4.01	3.79	3.88	4.01	4.15
	Amps	12.1	12.4	12.7	13.2	13.0	13.3	13.7	14.2	14.0	14.4	14.8	15.3	14.9	15.3	15.8	16.3	15.9	16.2	16.7	17.3	16.7	17.1	17.7	18.3
	Hi PR	250	269	284	296	280	301	318	332	318	343	362	377	363	390	412	430	408	439	464	484	451	485	512	534
	Lo PR	108	115	126	134	114	122	133	141	119	126	138	147	125	133	145	154	131	139	152	162	135	144	157	167
	MBh	41.1	41.9	43.9	46.8	40.1	40.9	42.8	45.7	39.2	39.9	41.8	44.6	38.2	39.0	40.8	43.5	36.3	37.0	38.8	41.3	33.6	34.3	35.9	38.3
	S/T	0.89	0.86	0.78	0.63	0.93	0.89	0.81	0.65	0.95	0.92	0.83	0.67	0.98	0.95	0.85	0.69	1.00	0.98	0.89	0.72	1.00	0.99	0.89	0.73
	ΔT	27	27	25	22	27	27	25	22	27	27	25	22	28	27	26	22	27	27	25	22	25	25	24	20
1250	kW	2.86	2.93	3.02	3.13	3.09	3.16	3.27	3.38	3.30	3.37	3.49	3.61	3.48	3.56	3.68	3.80	3.63	3.71	3.84	3.97	3.76	3.85	3.98	4.12
	Amps	12.0	12.3	12.6	13.1	12.9	13.2	13.6	14.1	13.9	14.2	14.7	15.2	14.8	15.2	15.6	16.2	15.7	16.1	16.6	17.2	16.6	17.0	17.5	18.2
	Hi PR	247	266	281	293	277	298	315	329	315	339	358	374	359	386	408	426	404	435	459	479	446	480	507	529
	Lo PR	107	114	124	132	113	120	131	140	118	125	137	145	123	131	143	153	129	138	150	160	134	142	155	166
	MBh	37.9	38.6	40.5	43.2	37.0	37.7	39.5	42.2	36.2	36.9	38.6	41.2	35.3	36.0	37.7	40.2	33.5	34.2	35.8	38.2	31.0	31.6	33.1	35.4
	S/T	0.86	0.83	0.75	0.61	0.89	0.86	0.78	0.63	0.92	0.88	0.80	0.65	0.95	0.91	0.82	0.67	0.98	0.95	0.86	0.69	0.99	0.96	0.86	0.70
	ΔT	27	27	26	22	28	27	26	22	28	27	26	22	28	28	26	23	28	27	26	22	26	25	24	21
	kW	2.79	2.85	2.95	3.05	3.02	3.08	3.19	3.29	3.21	3.29	3.40	3.51	3.39	3.46	3.58	3.70	3.53	3.62	3.74	3.87	3.66	3.75	3.87	4.01
	Amps	11.7	11.9	12.3	12.7	12.6	12.8	13.2	13.7	13.6	13.9	14.3	14.8	14.4	14.8	15.2	15.8	15.3	15.7	16.2	16.7	16.2	16.5	17.1	17.7
	Hi PR	240	258	272	284	269	289	306	319	306	329	348	362	348	375	396	413	392	422	445	464	433	466	492	513
Lo PR	104	110	121	128	110	117	127	136	114	121	132	141	120	127	139	148	126	134	146	155	130	138	151	161	

IDB: Entering Indoor Dry Bulb Temperature
 High & low pressures are measured at the liquid & suction access fittings.
 Shaded area reflects AHRH (TVA) conditions
 kW = Total system power
 Amps = outdoor unit amps (comp. + fans)

EXPANDED COOLING DATA — GPH1543M41*

IDB	AIRFLOW	OUTDOOR AMBIENT TEMPERATURE												ENTERING INDOOR WET BULB TEMPERATURE													
		65°F				75°F				85°F				95°F				105°F				115°F					
		59	63	67	71	59	63	67	71	59	63	67	71	59	63	67	71	59	63	67	71	59	63	67	71		
70	1400	MBh	39.2	40.7	44.5	-	38.3	39.7	43.5	-	37.4	38.8	42.5	-	36.5	37.8	41.4	-	34.7	35.9	39.4	-	32.1	33.3	36.5	-	
		S/T	0.70	0.59	0.41	-	0.73	0.61	0.42	-	0.75	0.62	0.43	-	0.77	0.64	0.45	-	0.80	0.67	0.46	-	0.81	0.67	0.47	-	
		ΔT	18	16	12	-	18	16	12	-	18	16	12	-	18	16	12	-	18	16	12	-	17	15	11	-	
	1250	kW	2.51	2.57	2.65	-	2.71	2.77	2.85	-	2.88	2.94	3.04	-	3.03	3.10	3.20	-	3.16	3.23	3.33	-	3.27	3.34	3.45	-	
		Amps	11.9	12.2	12.5	-	12.8	13.0	13.4	-	13.7	14.0	14.4	-	14.5	14.8	15.3	-	15.3	15.7	16.1	-	16.1	16.5	17.0	-	
		HI PR	228	245	259	-	256	275	291	-	291	313	331	-	331	357	377	-	373	401	424	-	412	443	468	-	
	1200	LO PR	107	114	124	-	113	120	131	-	118	125	136	-	123	131	143	-	129	138	150	-	134	142	155	-	
		MBh	38.1	39.5	43.2	-	37.2	38.5	42.2	-	36.3	37.6	41.2	-	35.4	36.7	40.2	-	33.7	34.9	38.2	-	31.2	32.3	35.4	-	
		S/T	0.67	0.56	0.39	-	0.69	0.58	0.40	-	0.71	0.59	0.41	-	0.74	0.61	0.43	-	0.76	0.64	0.44	-	0.77	0.64	0.45	-	
	75	1400	ΔT	19	16	12	-	19	16	12	-	19	16	12	-	19	17	13	-	19	16	12	-	18	15	12	-
			kW	2.49	2.55	2.63	-	2.69	2.74	2.83	-	2.85	2.92	3.01	-	3.00	3.07	3.17	-	3.13	3.20	3.31	-	3.24	3.31	3.42	-
			Amps	11.8	12.1	12.4	-	12.7	12.9	13.3	-	13.6	13.9	14.3	-	14.4	14.7	15.1	-	15.2	15.5	16.0	-	16.0	16.4	16.9	-
1250		HI PR	226	243	257	-	253	273	288	-	288	310	327	-	328	353	373	-	369	397	419	-	408	439	463	-	
		LO PR	106	113	123	-	112	119	130	-	116	124	135	-	122	130	142	-	128	136	149	-	132	141	154	-	
		MBh	37.7	39.1	42.8	-	36.8	38.2	41.8	-	35.9	37.3	40.8	-	35.1	36.3	39.8	-	33.3	34.5	37.8	-	30.9	32.0	35.0	-	
1200		S/T	0.66	0.55	0.38	-	0.69	0.57	0.40	-	0.71	0.59	0.41	-	0.73	0.61	0.42	-	0.76	0.63	0.44	-	0.76	0.64	0.44	-	
		ΔT	19	17	13	-	19	17	13	-	19	17	13	-	20	17	13	-	19	17	13	-	18	16	12	-	
		kW	2.47	2.52	2.60	-	2.66	2.71	2.80	-	2.82	2.89	2.98	-	2.97	3.04	3.14	-	3.10	3.17	3.27	-	3.20	3.28	3.38	-	
75		1400	Amps	11.7	12.0	12.3	-	12.5	12.8	13.1	-	13.5	13.7	14.1	-	14.3	14.6	15.0	-	15.1	15.4	15.8	-	15.8	16.2	16.7	-
			HI PR	223	240	253	-	250	269	284	-	284	306	323	-	324	348	368	-	364	392	414	-	403	433	457	-
			LO PR	105	111	121	-	110	118	128	-	115	122	133	-	121	128	140	-	126	134	147	-	131	139	152	-
	1250	MBh	39.9	41.1	44.5	47.7	39.0	40.1	43.4	46.6	38.0	39.2	42.4	45.5	37.1	38.2	41.3	44.4	35.2	36.3	39.3	42.2	32.7	33.6	36.4	39.1	
		S/T	0.80	0.71	0.54	0.35	0.83	0.74	0.56	0.36	0.85	0.76	0.57	0.37	0.88	0.78	0.59	0.38	0.91	0.81	0.62	0.40	0.92	0.82	0.62	0.40	
		ΔT	21	19	16	11	21	20	16	11	21	20	16	11	21	20	16	11	21	19	16	11	20	18	15	10	
	1200	kW	2.53	2.59	2.67	2.76	2.73	2.79	2.88	2.97	2.90	2.97	3.06	3.16	3.05	3.12	3.22	3.33	3.18	3.25	3.36	3.48	3.30	3.37	3.48	3.60	
		Amps	12.0	12.3	12.6	13.0	12.9	13.1	13.5	13.9	13.8	14.1	14.5	15.0	14.6	15.0	15.4	15.9	15.5	15.8	16.3	16.8	16.3	16.6	17.1	17.7	
		HI PR	230	248	262	273	258	278	294	306	294	316	334	348	335	360	380	397	377	405	428	446	416	448	473	493	
	75	1400	LO PR	108	115	126	134	114	122	133	141	119	126	138	147	125	133	145	154	131	139	152	162	135	144	157	167
			MBh	38.7	39.9	43.2	46.3	37.8	38.9	42.2	45.2	36.9	38.0	41.1	44.2	36.0	37.1	40.1	43.1	34.2	35.2	38.1	40.9	31.7	32.6	35.3	37.9
			S/T	0.76	0.68	0.52	0.33	0.79	0.71	0.53	0.34	0.81	0.72	0.55	0.35	0.84	0.75	0.57	0.36	0.87	0.78	0.59	0.38	0.87	0.78	0.59	0.38
1250		ΔT	22	20	16	11	22	20	17	11	22	20	17	11	22	20	17	12	22	20	16	11	20	19	15	11	
		kW	2.51	2.57	2.65	2.73	2.71	2.77	2.86	2.95	2.88	2.94	3.04	3.14	3.03	3.10	3.20	3.31	3.16	3.23	3.33	3.45	3.27	3.34	3.45	3.57	
		Amps	11.9	12.2	12.5	12.9	12.8	13.0	13.4	13.8	13.7	14.0	14.4	14.9	14.5	14.8	15.3	15.8	15.3	15.7	16.1	16.7	16.1	16.5	17.0	17.6	
1200		HI PR	228	245	259	270	256	275	291	303	291	313	331	345	331	357	377	393	373	401	424	442	412	443	468	488	
		LO PR	107	114	124	132	113	120	131	140	118	125	137	145	123	131	143	153	129	138	150	160	134	142	155	166	
		MBh	38.3	39.5	42.7	45.9	37.4	38.6	41.7	44.8	36.6	37.6	40.7	43.7	35.7	36.7	39.7	42.7	33.9	34.9	37.8	40.5	31.4	32.3	35.0	37.5	
1200		S/T	0.75	0.67	0.51	0.33	0.78	0.70	0.53	0.34	0.80	0.72	0.54	0.35	0.83	0.74	0.56	0.36	0.86	0.77	0.58	0.37	0.87	0.77	0.59	0.38	
		ΔT	22	20	17	12	22	21	17	12	22	21	17	12	23	21	17	12	22	21	17	12	21	19	16	11	
		kW	2.49	2.54	2.62	2.71	2.68	2.74	2.82	2.92	2.85	2.91	3.00	3.10	3.00	3.06	3.16	3.27	3.12	3.19	3.30	3.41	3.23	3.30	3.41	3.53	
1200	Amps	11.8	12.1	12.4	12.8	12.6	12.9	13.3	13.7	13.6	13.8	14.2	14.7	14.4	14.7	15.1	15.6	15.2	15.5	16.0	16.5	16.0	16.3	16.8	17.4		
	HI PR	225	242	256	267	253	272	287	299	287	309	326	340	327	352	372	388	368	396	418	436	407	438	462	482		
	LO PR	106	112	123	131	112	119	130	138	116	123	135	144	122	130	142	151	128	136	148	158	132	141	153	163		

IDB: Entering Indoor Dry Bulb Temperature
 High & low pressures are measured at the liquid & suction access fittings.

Shaded area reflects ACCA (TVA) conditions

kW = Total system power
 Amps = outdoor unit amps (comp.+ fans)

EXPANDED COOLING DATA — GPH1543M41* (CONT.)

IDB	AIRFLOW	OUTDOOR AMBIENT TEMPERATURE												ENTERING INDOOR WET BULB TEMPERATURE											
		65°F				75°F				85°F				95°F				105°F				115°F			
		59	63	67	71	59	63	67	71	59	63	67	71	59	63	67	71	59	63	67	71	59	63	67	71
1400	MBh	40.6	41.5	44.3	47.4	39.7	40.5	43.3	46.3	38.7	39.6	42.3	45.2	37.8	38.6	41.2	44.1	35.9	36.7	39.2	41.9	33.2	34.0	36.3	38.8
	S/T	0.88	0.82	0.67	0.50	0.91	0.85	0.69	0.52	0.93	0.87	0.71	0.53	0.96	0.90	0.73	0.55	1.00	0.94	0.76	0.57	1.00	0.94	0.77	0.57
	ΔT	23	22	19	16	24	23	20	16	24	23	20	16	24	23	20	16	24	23	20	16	22	21	18	15
	kW	2.56	2.61	2.69	2.78	2.75	2.81	2.90	3.00	2.93	2.99	3.09	3.19	3.08	3.15	3.25	3.36	3.21	3.28	3.39	3.51	3.32	3.40	3.51	3.63
	Amps	12.1	12.4	12.7	13.1	13.0	13.2	13.6	14.0	13.9	14.2	14.6	15.1	14.8	15.1	15.5	16.0	15.6	15.9	16.4	17.0	16.4	16.8	17.3	17.9
	HI PR	233	250	264	276	261	281	297	309	297	319	337	352	338	364	384	401	380	409	432	451	420	452	478	498
	LO PR	109	116	127	135	115	123	134	143	120	128	139	148	126	134	146	156	132	140	153	163	137	145	159	169
	MBh	39.4	40.3	43.0	46.0	38.5	39.3	42.0	44.9	37.6	38.4	41.0	43.9	36.7	37.5	40.0	42.8	34.8	35.6	38.0	40.6	32.3	33.0	35.2	37.7
	S/T	0.84	0.78	0.64	0.48	0.87	0.81	0.66	0.49	0.89	0.83	0.68	0.51	0.92	0.86	0.70	0.52	0.95	0.89	0.73	0.54	0.96	0.90	0.73	0.55
	ΔT	24	23	20	16	25	24	20	16	25	24	20	16	25	24	21	16	24	23	20	16	23	22	19	15
1250	kW	2.54	2.59	2.67	2.76	2.73	2.79	2.88	2.97	2.90	2.97	3.06	3.16	3.05	3.12	3.23	3.33	3.18	3.25	3.36	3.48	3.30	3.37	3.48	3.60
	Amps	12.0	12.3	12.6	13.0	12.9	13.1	13.5	13.9	13.8	14.1	14.5	15.0	14.6	15.0	15.4	15.9	15.5	15.8	16.3	16.8	16.3	16.6	17.1	17.7
	HI PR	230	248	262	273	258	278	294	306	294	316	334	348	335	360	380	397	377	405	428	446	416	448	473	493
	LO PR	108	115	126	134	114	122	133	141	119	126	138	147	125	133	145	154	131	139	152	162	135	144	157	167
	MBh	39.0	39.9	42.6	45.5	38.1	38.9	41.6	44.5	37.2	38.0	40.6	43.4	36.3	37.1	39.6	42.4	34.5	35.2	37.6	40.2	31.9	32.6	34.9	37.3
	S/T	0.83	0.78	0.63	0.47	0.86	0.80	0.65	0.49	0.88	0.82	0.67	0.50	0.91	0.85	0.69	0.52	0.94	0.88	0.72	0.54	0.95	0.89	0.72	0.54
	ΔT	25	24	21	16	25	24	21	17	25	24	21	17	25	24	21	17	25	24	21	17	23	22	19	15
	kW	2.51	2.56	2.64	2.73	2.70	2.76	2.85	2.94	2.87	2.93	3.03	3.13	3.02	3.09	3.19	3.30	3.15	3.22	3.33	3.44	3.26	3.33	3.44	3.56
	Amps	11.9	12.1	12.5	12.9	12.7	13.0	13.4	13.8	13.7	14.0	14.4	14.8	14.5	14.8	15.2	15.7	15.3	15.6	16.1	16.6	16.1	16.5	17.0	17.5
	HI PR	227	245	258	269	255	275	290	302	290	312	330	344	330	356	376	392	372	400	422	441	411	442	467	487
LO PR	107	114	124	132	113	120	131	139	117	125	136	145	123	131	143	152	129	137	150	160	133	142	155	165	

1400	MBh	41.3	42.1	44.1	47.0	40.3	41.1	43.1	45.9	39.4	40.1	42.0	44.9	38.4	39.2	41.0	43.8	36.5	37.2	39.0	41.6	33.8	34.5	36.1	38.5
	S/T	0.92	0.89	0.80	0.65	0.95	0.92	0.83	0.67	0.98	0.94	0.85	0.69	1.00	0.97	0.88	0.71	1.00	1.00	0.91	0.74	1.00	1.00	0.92	0.75
	ΔT	25	25	23	20	25	25	23	20	25	25	23	20	25	25	24	20	24	24	23	20	22	23	22	19
	kW	2.58	2.63	2.71	2.80	2.77	2.83	2.93	3.02	2.95	3.02	3.11	3.22	3.11	3.17	3.28	3.39	3.24	3.31	3.42	3.54	3.35	3.43	3.54	3.66
	Amps	12.2	12.5	12.8	13.2	13.1	13.3	13.7	14.2	14.0	14.3	14.7	15.2	14.9	15.2	15.6	16.2	15.7	16.1	16.5	17.1	16.6	16.9	17.4	18.0
	HI PR	235	253	267	278	264	284	300	312	300	323	341	355	342	368	388	405	384	413	437	455	425	457	482	503
	LO PR	110	117	128	136	117	124	135	144	121	129	141	150	127	135	148	157	133	142	155	165	138	147	160	171
	MBh	40.1	40.9	42.8	45.7	39.2	39.9	41.8	44.6	38.2	39.0	40.8	43.5	37.3	38.0	39.8	42.5	35.4	36.1	37.8	40.4	32.8	33.5	35.0	37.4
	S/T	0.88	0.85	0.76	0.62	0.91	0.88	0.79	0.64	0.93	0.90	0.81	0.66	0.96	0.93	0.84	0.68	1.00	0.96	0.87	0.70	1.00	0.97	0.88	0.71
	ΔT	26	25	24	21	26	26	24	21	26	26	24	21	26	26	25	21	26	26	24	21	24	24	23	20
1250	kW	2.56	2.61	2.69	2.78	2.75	2.81	2.90	3.00	2.93	2.99	3.09	3.19	3.08	3.15	3.25	3.36	3.21	3.28	3.39	3.51	3.32	3.40	3.51	3.63
	Amps	12.1	12.4	12.7	13.1	13.0	13.2	13.6	14.0	13.9	14.2	14.6	15.1	14.8	15.1	15.5	16.0	15.6	15.9	16.4	17.0	16.4	16.8	17.3	17.9
	HI PR	233	250	264	276	261	281	297	309	297	319	337	352	338	364	384	401	380	409	432	451	420	452	478	498
	LO PR	109	116	127	135	115	123	134	143	120	128	139	148	126	134	146	156	132	140	153	163	137	145	159	169
	MBh	39.7	40.5	42.4	45.2	38.8	39.5	41.4	44.2	37.9	38.6	40.4	43.1	36.9	37.6	39.4	42.1	35.1	35.8	37.5	40.0	32.5	33.1	34.7	37.0
	S/T	0.87	0.84	0.76	0.61	0.90	0.87	0.78	0.63	0.92	0.89	0.80	0.65	0.95	0.92	0.83	0.67	0.99	0.95	0.86	0.70	1.00	0.96	0.87	0.70
	ΔT	26	26	25	21	27	26	25	22	27	26	25	22	27	26	25	22	27	26	25	22	25	24	23	20
	kW	2.53	2.58	2.66	2.75	2.72	2.78	2.87	2.97	2.90	2.96	3.05	3.16	3.05	3.11	3.22	3.32	3.18	3.25	3.35	3.47	3.29	3.36	3.47	3.59
	Amps	12.0	12.2	12.6	13.0	12.8	13.1	13.5	13.9	13.8	14.1	14.5	15.0	14.6	14.9	15.4	15.9	15.4	15.8	16.2	16.8	16.2	16.6	17.1	17.7
	HI PR	230	247	261	272	258	277	293	305	293	315	333	347	334	359	379	396	375	404	427	445	415	446	471	492
LO PR	108	115	125	133	114	121	132	141	118	126	137	146	124	132	144	154	130	139	151	161	135	143	157	167	

IDB: Entering Indoor Dry Bulb Temperature
 High & low pressures are measured at the liquid & suction access fittings.
 Shaded area reflects AHRI (TVA) conditions
 kW = Total system power
 Amps = outdoor unit amps (comp. + fans)

EXPANDED COOLING DATA — GPH1548M41* — LOW STAGE

IDB	AIRFLOW	OUTDOOR AMBIENT TEMPERATURE												ENTERING INDOOR WET BULB TEMPERATURE											
		65°F				75°F				85°F				95°F				105°F				115°F			
		59	63	67	71	59	63	67	71	59	63	67	71	59	63	67	71	59	63	67	71	59	63	67	71
1350	MBh	33.4	34.6	37.9	-	32.6	33.8	37.0	-	31.8	33.0	36.1	-	31.0	32.2	35.2	-	29.5	30.6	33.5	-	27.3	28.3	31.0	-
	S/T	0.76	0.64	0.44	-	0.79	0.66	0.46	-	0.81	0.68	0.47	-	0.84	0.70	0.48	-	0.87	0.73	0.50	-	0.88	0.73	0.51	-
	DT	17	15	11	-	18	15	12	-	18	15	12	-	18	15	12	-	17	15	11	-	16	14	11	-
	kW	2.16	2.21	2.27	-	2.32	2.37	2.44	-	2.46	2.51	2.59	-	2.58	2.64	2.72	-	2.69	2.74	2.83	-	2.78	2.84	2.93	-
	Amps	9.3	9.5	9.7	-	9.9	10.1	10.4	-	10.6	10.8	11.2	-	11.2	11.5	11.8	-	11.9	12.1	12.5	-	12.5	12.7	13.1	-
	Hi PR	217	233	247	-	243	262	277	-	277	298	315	-	315	339	358	-	355	382	403	-	392	422	445	-
	Lo PR	113	120	131	-	119	127	139	-	124	132	144	-	130	139	151	-	137	145	159	-	141	150	164	-
1200	MBh	32.4	33.6	36.8	-	31.6	32.8	35.9	-	30.9	32.0	35.1	-	30.1	31.2	34.2	-	28.6	29.7	32.5	-	26.5	27.5	30.1	-
	S/T	0.73	0.61	0.42	-	0.75	0.63	0.44	-	0.77	0.65	0.45	-	0.80	0.67	0.46	-	0.83	0.69	0.48	-	0.84	0.70	0.48	-
	DT	18	16	12	-	18	16	12	-	18	16	12	-	18	16	12	-	18	16	12	-	17	15	11	-
	kW	2.15	2.19	2.26	-	2.30	2.35	2.42	-	2.44	2.49	2.57	-	2.56	2.62	2.70	-	2.67	2.72	2.81	-	2.75	2.81	2.90	-
	Amps	9.2	9.4	9.7	-	9.9	10.0	10.3	-	10.6	10.8	11.1	-	11.2	11.4	11.7	-	11.8	12.0	12.4	-	12.4	12.6	13.0	-
	Hi PR	215	231	244	-	241	259	274	-	274	295	311	-	312	336	355	-	351	378	399	-	388	418	441	-
	Lo PR	112	119	130	-	118	126	137	-	123	131	143	-	129	137	150	-	135	144	157	-	140	149	163	-
1050	MBh	29.9	31.0	34.0	-	29.2	30.3	33.2	-	28.5	29.5	32.4	-	27.8	28.8	31.6	-	26.4	27.4	30.0	-	24.5	25.4	27.8	-
	S/T	0.70	0.59	0.41	-	0.73	0.61	0.42	-	0.75	0.62	0.43	-	0.77	0.64	0.45	-	0.80	0.67	0.46	-	0.81	0.67	0.47	-
	DT	18	16	12	-	19	16	12	-	19	16	12	-	19	16	12	-	18	16	12	-	17	15	11	-
	kW	2.10	2.14	2.20	-	2.25	2.30	2.37	-	2.38	2.43	2.51	-	2.50	2.55	2.63	-	2.60	2.66	2.74	-	2.69	2.74	2.83	-
	Amps	9.0	9.2	9.5	-	9.6	9.8	10.1	-	10.3	10.5	10.8	-	10.9	11.1	11.4	-	11.5	11.7	12.1	-	12.1	12.3	12.7	-
	Hi PR	208	224	237	-	234	252	266	-	266	286	302	-	303	326	344	-	341	367	387	-	376	405	428	-
	Lo PR	109	116	126	-	115	122	133	-	119	127	138	-	125	133	145	-	131	140	152	-	136	144	158	-
1350	MBh	33.9	34.9	37.8	40.6	33.1	34.1	36.9	39.6	32.4	33.3	36.1	38.7	31.6	32.5	35.2	37.8	30.0	30.9	33.4	35.9	27.8	28.6	31.0	33.2
	S/T	0.87	0.78	0.59	0.38	0.90	0.80	0.61	0.39	0.92	0.82	0.62	0.40	0.95	0.85	0.64	0.41	0.99	0.88	0.67	0.43	1.00	0.89	0.67	0.43
	DT	20	18	15	10	20	19	15	11	20	19	15	11	20	19	15	11	20	19	15	11	19	17	14	10
	kW	2.18	2.22	2.29	2.36	2.34	2.39	2.46	2.54	2.48	2.53	2.61	2.69	2.60	2.66	2.74	2.83	2.71	2.77	2.85	2.95	2.80	2.86	2.95	3.05
	Amps	9.4	9.6	9.8	10.1	10.0	10.2	10.5	10.8	10.7	10.9	11.2	11.6	11.3	11.6	11.9	12.3	12.0	12.2	12.6	13.0	12.6	12.8	13.2	13.6
	Hi PR	219	236	249	260	246	265	279	291	280	301	318	331	319	343	362	378	358	386	407	425	396	426	450	469
	Lo PR	114	121	133	141	121	128	140	149	125	133	146	155	132	140	153	163	138	147	160	171	143	152	166	177
1200	MBh	32.9	33.9	36.7	39.4	32.2	33.1	35.9	38.5	31.4	32.3	35.0	37.6	30.6	31.6	34.2	36.7	29.1	30.0	32.4	34.8	27.0	27.8	30.1	32.3
	S/T	0.83	0.74	0.56	0.36	0.86	0.77	0.58	0.37	0.88	0.79	0.60	0.38	0.91	0.81	0.61	0.40	0.94	0.84	0.64	0.41	0.95	0.85	0.64	0.41
	DT	21	19	16	11	21	19	16	11	21	19	16	11	21	20	16	11	21	19	16	11	20	18	15	10
	kW	2.16	2.21	2.27	2.34	2.32	2.37	2.44	2.52	2.46	2.51	2.59	2.67	2.58	2.64	2.72	2.81	2.69	2.74	2.83	2.92	2.78	2.84	2.93	3.02
	Amps	9.3	9.5	9.7	10.0	9.9	10.1	10.4	10.7	10.6	10.9	11.2	11.5	11.2	11.5	11.8	12.2	11.9	12.1	12.5	12.9	12.5	12.7	13.1	13.5
	Hi PR	217	233	247	257	243	262	277	289	277	298	315	328	315	339	358	374	355	382	403	421	392	422	445	465
	Lo PR	113	120	131	140	119	127	139	148	124	132	144	154	130	139	151	161	137	145	159	169	141	150	164	175
1050	MBh	30.4	31.3	33.9	36.4	29.7	30.6	33.1	35.5	29.0	29.9	32.3	34.7	28.3	29.1	31.5	33.8	26.9	27.7	29.9	32.1	24.9	25.6	27.7	29.8
	S/T	0.80	0.71	0.54	0.35	0.83	0.74	0.56	0.36	0.85	0.76	0.57	0.37	0.88	0.78	0.59	0.38	0.91	0.81	0.62	0.40	0.92	0.82	0.62	0.40
	DT	21	20	16	11	22	20	16	11	22	20	16	11	22	20	16	11	21	20	16	11	20	18	15	10
	kW	2.11	2.16	2.22	2.29	2.27	2.31	2.38	2.46	2.40	2.45	2.53	2.61	2.52	2.57	2.65	2.74	2.62	2.68	2.76	2.85	2.71	2.77	2.86	2.95
	Amps	9.1	9.3	9.5	9.8	9.7	9.9	10.2	10.5	10.4	10.6	10.9	11.2	11.0	11.2	11.5	11.9	11.6	11.8	12.2	12.6	12.2	12.4	12.8	13.2
	Hi PR	210	226	239	249	236	254	268	280	269	289	305	318	306	329	348	363	344	370	391	408	380	409	432	451
	Lo PR	110	117	127	136	116	123	135	143	120	128	140	149	127	135	147	156	133	141	154	164	137	146	159	170

IDB: Entering Indoor Dry Bulb Temperature
 High & low pressures are measured at the liquid & suction access fittings.
 Shaded area reflects ACCA (TVA) conditions
 kW = Total system power
 Amps = outdoor unit amps (comp.+ fans)

EXPANDED COOLING DATA — GPH1548M41* — LOW STAGE (CONT.)

IDB	AIRFLOW	OUTDOOR AMBIENT TEMPERATURE												ENTERING INDOOR WET BULB TEMPERATURE												
		65°F				75°F				85°F				95°F				105°F				115°F				
		59	63	67	71	59	63	67	71	59	63	67	71	59	63	67	71	59	63	67	71	59	63	67	71	
80	1350	MBh	34.5	35.3	37.7	40.3	33.7	34.5	36.8	39.4	32.9	33.6	35.9	38.4	32.1	32.8	35.1	37.5	30.5	31.2	33.3	35.6	28.3	28.9	30.9	33.0
		S/T	0.95	0.89	0.73	0.54	1.00	0.93	0.75	0.56	1.00	0.95	0.77	0.58	1.00	1.00	0.80	0.60	1.00	1.00	0.83	0.62	1.00	1.00	0.83	0.62
	ΔT	22	21	19	15	23	22	19	15	22	22	19	15	22	22	19	15	21	21	19	15	19	20	18	14	
	kW	2.20	2.24	2.31	2.38	2.36	2.41	2.48	2.56	2.50	2.55	2.63	2.71	2.62	2.68	2.76	2.85	2.73	2.79	2.88	2.97	2.82	2.88	2.98	3.07	
	Amps	9.5	9.6	9.9	10.2	10.1	10.3	10.6	10.9	10.8	11.0	11.3	11.7	11.4	11.7	12.0	12.4	12.0	12.3	12.7	13.1	12.7	12.9	13.3	13.8	
	Hi PR	221	238	252	262	248	267	282	294	282	304	321	335	322	346	366	381	362	390	411	429	400	430	454	474	
	Lo PR	115	123	134	143	122	130	142	151	127	135	147	157	133	142	155	165	139	148	162	172	144	153	168	178	
	MBh	33.5	34.3	36.6	39.1	32.7	33.5	35.8	38.2	32.0	32.7	34.9	37.3	31.2	31.9	34.1	36.4	29.6	30.3	32.3	34.6	27.4	28.0	30.0	32.0	
	S/T	0.91	0.85	0.69	0.52	0.94	0.88	0.72	0.54	0.96	0.90	0.74	0.55	1.00	0.93	0.76	0.57	1.00	0.97	0.79	0.59	1.00	0.98	0.80	0.59	
	ΔT	23	22	19	16	24	23	20	16	24	23	20	16	24	23	20	16	23	22	20	16	21	21	18	15	
1200	1350	MBh	2.18	2.22	2.29	2.36	2.34	2.39	2.46	2.54	2.48	2.53	2.61	2.69	2.60	2.66	2.74	2.83	2.71	2.77	2.85	2.95	2.80	2.86	2.95	3.05
		Amps	9.4	9.6	9.8	10.1	10.0	10.2	10.5	10.8	10.7	10.9	11.2	11.6	11.3	11.6	11.9	12.3	12.0	12.2	12.6	13.0	12.6	12.8	13.2	13.6
	Hi PR	219	236	249	260	246	265	279	291	280	301	318	332	319	343	362	378	358	386	407	425	396	426	450	469	
	Lo PR	114	122	133	141	121	128	140	149	125	133	146	155	132	140	153	163	138	147	160	171	143	152	166	177	
	MBh	30.9	31.6	33.8	36.1	30.2	30.9	33.0	35.3	29.5	30.2	32.2	34.4	28.8	29.4	31.4	33.6	27.3	27.9	29.9	31.9	25.3	25.9	27.7	29.6	
	S/T	0.88	0.82	0.67	0.50	0.91	0.85	0.69	0.52	0.93	0.87	0.71	0.53	0.96	0.90	0.73	0.55	1.00	0.93	0.76	0.57	1.00	0.94	0.77	0.57	
	ΔT	24	23	20	16	24	23	20	16	24	23	20	16	24	23	20	16	24	23	20	16	22	21	19	15	
	kW	2.13	2.17	2.24	2.31	2.28	2.33	2.40	2.48	2.42	2.47	2.55	2.63	2.54	2.59	2.68	2.76	2.64	2.70	2.78	2.87	2.73	2.79	2.88	2.97	
	Amps	9.2	9.4	9.6	9.9	9.8	10.0	10.2	10.6	10.5	10.7	11.0	11.3	11.1	11.3	11.6	12.0	11.7	11.9	12.3	12.7	12.3	12.5	12.9	13.3	
	Hi PR	213	229	242	252	239	257	271	283	271	292	308	322	309	333	351	366	348	374	395	412	384	413	436	455	
Lo PR	111	118	129	137	117	125	136	145	122	129	141	150	128	136	148	158	134	142	156	166	139	147	161	171		
85	1350	MBh	35.1	35.8	37.5	40.0	34.3	35.0	36.6	39.1	33.5	34.2	35.8	38.2	32.7	33.3	34.9	37.2	31.1	31.7	33.2	35.4	28.8	29.3	30.7	32.8
		S/T	1.00	0.96	0.87	0.70	1.00	1.00	0.90	0.73	1.00	1.00	0.92	0.75	1.00	1.00	0.95	0.77	1.00	1.00	0.99	0.80	1.00	1.00	1.00	0.81
	ΔT	24	23	22	19	23	24	22	19	23	23	22	19	22	23	23	20	21	22	22	19	20	20	21	18	
	kW	2.21	2.26	2.33	2.40	2.38	2.42	2.50	2.58	2.52	2.57	2.65	2.74	2.64	2.70	2.79	2.88	2.75	2.81	2.90	3.00	2.84	2.91	3.00	3.10	
	Amps	9.5	9.7	10.0	10.3	10.2	10.4	10.6	11.0	10.9	11.1	11.4	11.8	11.5	11.8	12.1	12.5	12.1	12.4	12.8	13.2	12.8	13.0	13.4	13.9	
	Hi PR	224	241	254	265	251	270	285	297	285	307	324	338	325	350	369	385	366	393	415	433	404	435	459	479	
	Lo PR	117	124	135	144	123	131	143	152	128	136	149	158	134	143	156	166	141	150	164	174	146	155	169	180	
	MBh	34.1	34.8	36.4	38.9	33.3	34.0	35.6	38.0	32.5	33.2	34.7	37.0	31.7	32.3	33.9	36.1	30.1	30.7	32.2	34.3	27.9	28.5	29.8	31.8	
	S/T	0.95	0.92	0.83	0.67	0.99	0.95	0.86	0.70	1.00	0.98	0.88	0.71	1.00	1.00	0.91	0.74	1.00	1.00	0.94	0.77	1.00	1.00	0.95	0.77	
	ΔT	25	24	23	20	25	25	23	20	25	25	23	20	24	25	24	20	23	24	23	20	21	22	22	19	
kW	2.20	2.24	2.31	2.38	2.36	2.41	2.48	2.56	2.50	2.55	2.63	2.71	2.62	2.68	2.76	2.85	2.73	2.79	2.88	2.97	2.82	2.88	2.98	3.07		
Amps	9.5	9.6	9.9	10.2	10.1	10.3	10.6	10.9	10.8	11.0	11.3	11.7	11.4	11.7	12.0	12.4	12.0	12.3	12.7	13.1	12.7	12.9	13.3	13.8		
Hi PR	221	238	252	262	248	267	282	294	282	304	321	335	322	346	366	381	362	390	411	429	400	430	454	474		
Lo PR	115	123	134	143	122	130	142	151	127	135	147	157	133	142	155	165	139	148	162	172	144	153	168	178		
MBh	31.5	32.1	33.6	35.9	30.8	31.4	32.8	35.0	30.0	30.6	32.1	34.2	29.3	29.9	31.3	33.4	27.8	28.4	29.7	31.7	25.8	26.3	27.5	29.4		
S/T	0.92	0.89	0.80	0.65	0.95	0.92	0.83	0.67	0.98	0.94	0.85	0.69	1.00	0.97	0.88	0.71	1.00	1.00	0.91	0.74	1.00	1.00	0.92	0.74		
ΔT	25	25	24	20	26	25	24	21	26	25	24	21	26	25	24	21	24	25	24	20	23	23	22	19		
kW	2.15	2.19	2.25	2.32	2.30	2.35	2.42	2.50	2.44	2.49	2.57	2.65	2.56	2.62	2.70	2.78	2.66	2.72	2.81	2.90	2.75	2.81	2.90	3.00		
Amps	9.2	9.4	9.7	10.0	9.8	10.0	10.3	10.6	10.6	10.8	11.1	11.4	11.2	11.4	11.7	12.1	11.8	12.0	12.4	12.8	12.4	12.6	13.0	13.4		
Hi PR	215	231	244	254	241	259	274	286	274	295	311	325	312	336	355	370	351	378	399	416	388	417	441	460		
Lo PR	112	119	130	138	118	126	137	146	123	131	143	152	129	137	150	160	135	144	157	167	140	149	162	173		

Shaded area reflects AHRI (TVA) conditions
 kW = Total system power
 Amps = outdoor unit amps (comp.+ fans)

IDB: Entering Indoor Dry Bulb Temperature
 High & low pressures are measured at the liquid & suction access fittings.

www.goodmanmfg.com

EXPANDED COOLING DATA — GPH1548M41* — HIGH STAGE

IDB	AIRFLOW	OUTDOOR AMBIENT TEMPERATURE												ENTERING INDOOR WET BULB TEMPERATURE													
		65°F				75°F				85°F				95°F				105°F				115°F					
		59	63	67	71	59	63	67	71	59	63	67	71	59	63	67	71	59	63	67	71	59	63	67	71		
70	1900	MBh	45.0	46.7	51.2	-	44.0	45.6	50.0	-	43.0	44.5	48.8	-	41.9	43.4	47.6	-	39.8	41.3	45.2	-	36.9	38.2	41.9	-	
		S/T	0.77	0.64	0.45	-	0.80	0.67	0.46	-	0.82	0.68	0.47	-	0.85	0.71	0.49	-	0.88	0.73	0.51	-	0.88	0.74	0.51	-	
	1700	DT	17	15	11	-	17	15	11	-	17	15	11	-	17	15	11	-	17	15	11	-	16	14	10	-	
		kW	3.25	3.31	3.41	-	3.48	3.55	3.65	-	3.68	3.76	3.87	-	3.86	3.94	4.06	-	4.01	4.10	4.23	-	4.15	4.23	4.37	-	
	1500	Amps	13.7	13.9	14.3	-	14.6	14.9	15.3	-	15.6	15.9	16.4	-	16.5	16.8	17.3	-	17.4	17.8	18.3	-	18.3	18.7	19.2	-	
		Hi PR	232	249	263	-	260	280	296	-	296	318	336	-	337	363	383	-	379	408	431	-	419	451	476	-	
	75	1900	Lo PR	110	117	128	-	116	124	135	-	121	129	140	-	127	135	147	-	133	142	155	-	138	146	160	-
			MBh	44.4	46.0	50.4	-	43.3	44.9	49.2	-	42.3	43.9	48.1	-	41.3	42.8	46.9	-	39.2	40.7	44.5	-	36.3	37.7	41.3	-
		1700	S/T	0.74	0.62	0.43	-	0.76	0.64	0.44	-	0.78	0.65	0.45	-	0.81	0.68	0.47	-	0.84	0.70	0.49	-	0.85	0.71	0.49	-
			DT	18	15	12	-	18	16	12	-	18	16	12	-	18	16	12	-	18	15	12	-	17	14	11	-
1500		kW	3.23	3.30	3.39	-	3.46	3.53	3.64	-	3.66	3.74	3.85	-	3.84	3.92	4.04	-	3.99	4.08	4.20	-	4.12	4.21	4.34	-	
		Amps	13.6	13.9	14.2	-	14.5	14.8	15.2	-	15.5	15.8	16.3	-	16.4	16.8	17.2	-	17.3	17.7	18.2	-	18.2	18.6	19.1	-	
77		1900	Hi PR	230	248	262	-	258	278	293	-	294	316	334	-	335	360	380	-	376	405	428	-	416	447	473	-
			Lo PR	109	116	127	-	115	123	134	-	120	128	139	-	126	134	146	-	132	141	153	-	137	145	159	-
		1700	MBh	42.2	43.7	47.9	-	41.2	42.7	46.8	-	40.2	41.7	45.7	-	39.2	40.7	44.5	-	37.3	38.6	42.3	-	34.5	35.8	39.2	-
			S/T	0.71	0.59	0.41	-	0.73	0.61	0.42	-	0.75	0.63	0.43	-	0.78	0.65	0.45	-	0.80	0.67	0.47	-	0.81	0.68	0.47	-
	1500	DT	18	16	12	-	18	16	12	-	19	16	12	-	19	16	12	-	18	16	12	-	17	15	11	-	
		kW	3.19	3.25	3.34	-	3.41	3.48	3.58	-	3.61	3.68	3.79	-	3.78	3.86	3.98	-	3.93	4.01	4.14	-	4.06	4.14	4.27	-	
	79	1900	Amps	13.4	13.7	14.0	-	14.3	14.6	15.0	-	15.3	15.6	16.0	-	16.2	16.5	17.0	-	17.0	17.4	17.9	-	17.9	18.3	18.8	-
			Hi PR	226	243	256	-	253	272	288	-	288	310	327	-	328	353	373	-	369	397	419	-	407	439	463	-
		1700	Lo PR	107	114	124	-	113	120	131	-	118	125	137	-	124	131	143	-	129	138	150	-	134	142	156	-
			MBh	45.8	47.2	51.1	54.8	44.7	46.1	49.9	53.5	43.7	45.0	48.7	52.2	42.6	43.9	47.5	51.0	40.5	41.7	45.1	48.4	37.5	38.6	41.8	44.9
1500		S/T	0.88	0.78	0.59	0.38	0.91	0.81	0.61	0.40	0.93	0.83	0.63	0.41	0.96	0.86	0.65	0.42	1.00	0.89	0.67	0.43	1.00	0.90	0.68	0.44	
		DT	19	18	15	10	20	18	15	10	20	18	15	10	20	18	15	10	20	18	15	10	18	17	14	10	
81		1900	kW	3.27	3.34	3.44	3.54	3.51	3.58	3.68	3.80	3.71	3.79	3.90	4.02	3.89	3.97	4.10	4.22	4.05	4.13	4.26	4.39	4.18	4.27	4.40	4.54
			Amps	13.8	14.0	14.4	14.9	14.7	15.0	15.4	15.9	15.7	16.0	16.5	17.0	16.6	17.0	17.5	18.0	17.5	17.9	18.4	19.0	18.4	18.8	19.4	20.0
		1700	Hi PR	234	252	266	277	263	283	299	311	299	322	340	354	340	366	387	403	383	412	435	454	423	455	481	501
			Lo PR	111	118	129	138	117	125	136	145	122	130	142	151	128	136	149	159	134	143	156	166	139	148	161	172
	1500	MBh	45.1	46.5	50.3	54.0	44.1	45.4	49.1	52.7	43.0	44.3	48.0	51.5	42.0	43.2	46.8	50.2	39.9	41.1	44.5	47.7	36.9	38.0	41.2	44.2	
		S/T	0.84	0.75	0.57	0.37	0.87	0.78	0.59	0.38	0.89	0.80	0.60	0.39	0.92	0.82	0.62	0.40	0.95	0.85	0.65	0.42	0.96	0.86	0.65	0.42	
	83	1900	DT	20	19	15	11	21	19	16	11	21	19	16	11	21	19	16	11	21	19	16	11	19	18	15	10
			kW	3.26	3.32	3.42	3.52	3.49	3.56	3.66	3.78	3.69	3.77	3.88	4.00	3.87	3.95	4.07	4.20	4.02	4.11	4.24	4.37	4.16	4.24	4.38	4.52
		1700	Amps	13.7	14.0	14.3	14.8	14.6	14.9	15.3	15.8	15.6	16.0	16.4	16.9	16.5	16.9	17.4	17.9	17.4	17.8	18.3	18.9	18.3	18.7	19.3	19.9
			Hi PR	233	250	264	276	261	281	296	309	297	319	337	352	338	364	384	401	380	409	432	451	420	452	477	498
1500		Lo PR	110	117	128	137	117	124	135	144	121	129	141	150	127	135	148	158	133	142	155	165	138	147	160	171	
		MBh	42.9	44.1	47.8	51.3	41.9	43.1	46.7	50.1	40.9	42.1	45.6	48.9	39.9	41.1	44.5	47.7	37.9	39.0	42.2	45.3	35.1	36.1	39.1	42.0	
85		1900	S/T	0.80	0.72	0.54	0.35	0.83	0.74	0.56	0.36	0.85	0.76	0.58	0.37	0.88	0.79	0.60	0.38	0.91	0.82	0.62	0.40	0.92	0.82	0.62	0.40
			DT	21	19	16	11	21	20	16	11	21	20	16	11	22	20	16	11	21	19	16	11	20	18	15	10
		1700	kW	3.21	3.27	3.37	3.47	3.44	3.50	3.61	3.72	3.64	3.71	3.82	3.94	3.81	3.89	4.01	4.13	3.96	4.04	4.17	4.30	4.09	4.18	4.31	4.44
			Amps	13.5	13.8	14.1	14.6	14.4	14.7	15.1	15.5	15.4	15.7	16.2	16.7	16.3	16.6	17.1	17.6	17.2	17.5	18.0	18.6	18.0	18.4	18.9	19.6
	1500	Hi PR	228	245	259	270	256	275	291	303	291	313	330	345	331	356	376	393	373	401	423	442	412	443	468	488	
		Lo PR	108	115	126	134	114	122	133	141	119	126	138	147	125	133	145	154	131	139	152	162	135	144	157	167	

IDB: Entering Indoor Dry Bulb Temperature
 High & low pressures are measured at the liquid & suction access fittings.

Shaded area reflects ACCA (ITVA) conditions

kW = Total system power
 Amps = outdoor unit amps (comp.+ fans)

EXPANDED COOLING DATA — GPH1548M41* — HIGH STAGE (CONT.)

IDB	AIRFLOW	OUTDOOR AMBIENT TEMPERATURE												ENTERING INDOOR WET BULB TEMPERATURE													
		65°F				75°F				85°F				95°F				105°F				115°F					
		59	63	67	71	59	63	67	71	59	63	67	71	59	63	67	71	59	63	67	71	59	63	67	71		
80	1900	MBh	46.6	47.6	50.9	54.4	45.5	46.5	49.7	53.1	44.5	45.4	48.5	51.9	43.4	44.3	47.3	50.6	41.2	42.1	45.0	48.1	38.2	39.0	41.7	44.5	
		S/T	0.96	0.90	0.73	0.55	1.00	0.93	0.76	0.57	1.00	0.96	0.78	0.58	1.00	1.00	0.80	0.60	1.00	1.00	0.83	0.62	1.00	1.00	0.84	0.63	
	1700	ΔT	22	21	18	14	22	21	18	15	21	21	18	15	21	21	18	15	20	20	18	15	18	19	17	14	
		kW	3.30	3.36	3.46	3.56	3.53	3.60	3.71	3.82	3.74	3.82	3.93	4.05	3.92	4.00	4.13	4.26	4.08	4.16	4.29	4.43	4.21	4.30	4.44	4.58	
	1500	Amps	13.9	14.1	14.5	15.0	14.8	15.1	15.5	16.0	15.8	16.2	16.6	17.2	16.8	17.1	17.6	18.2	17.7	18.0	18.6	19.2	18.6	19.0	19.5	20.2	
		Hi PR	236	254	269	280	265	286	302	315	302	325	343	358	344	370	391	407	387	416	439	458	427	460	486	506	
	85	1900	Lo PR	112	119	130	139	119	126	138	147	123	131	143	153	130	138	150	160	136	144	158	168	140	149	163	174
			MBh	45.9	46.9	50.1	53.6	44.9	45.8	49.0	52.4	43.8	44.8	47.8	51.1	42.7	43.7	46.7	49.9	40.6	41.5	44.3	47.4	37.6	38.4	41.1	43.9
		1700	S/T	0.92	0.86	0.70	0.52	0.95	0.89	0.73	0.54	0.98	0.92	0.75	0.56	1.00	0.95	0.77	0.58	1.00	0.98	0.80	0.60	1.00	0.99	0.81	0.60
			ΔT	23	22	19	15	23	22	19	15	23	22	19	15	23	22	19	16	22	22	19	15	20	21	18	14
1500		kW	3.28	3.35	3.44	3.55	3.51	3.58	3.69	3.80	3.72	3.80	3.91	4.03	3.90	3.98	4.11	4.23	4.06	4.14	4.27	4.41	4.19	4.28	4.41	4.55	
		Amps	13.8	14.1	14.5	14.9	14.7	15.0	15.4	15.9	15.8	16.1	16.5	17.1	16.7	17.0	17.5	18.1	17.6	17.9	18.5	19.1	18.5	18.9	19.4	20.1	
85		1900	Hi PR	235	253	267	278	264	284	299	312	300	323	341	355	341	367	388	405	384	413	436	455	424	457	482	503
			Lo PR	112	119	130	138	118	125	137	146	122	130	142	151	129	137	149	159	135	143	157	167	139	148	162	172
		1700	MBh	43.6	44.6	47.6	50.9	42.6	43.6	46.5	49.7	41.6	42.5	45.4	48.6	40.6	41.5	44.3	47.4	38.6	39.4	42.1	45.0	35.7	36.5	39.0	41.7
			S/T	0.88	0.83	0.67	0.50	0.91	0.86	0.70	0.52	0.94	0.88	0.71	0.53	0.97	0.91	0.74	0.55	1.00	0.94	0.77	0.57	1.01	0.95	0.77	0.58
	1500	ΔT	24	23	20	16	24	23	20	16	24	23	20	16	24	23	20	16	24	24	20	16	22	21	18	15	
		kW	3.23	3.30	3.39	3.49	3.46	3.53	3.64	3.75	3.66	3.74	3.85	3.97	3.84	3.92	4.04	4.17	3.99	4.08	4.20	4.33	4.12	4.21	4.34	4.48	
	85	1900	Amps	13.6	13.9	14.2	14.7	14.5	14.8	15.2	15.7	15.5	15.8	16.3	16.8	16.4	16.8	17.2	17.8	17.3	17.7	18.2	18.8	18.2	18.6	19.1	19.7
			Hi PR	230	248	262	273	258	278	293	306	294	316	334	348	335	360	380	396	376	405	428	446	416	447	473	493
		1700	Lo PR	109	116	127	135	115	123	134	143	120	128	139	148	126	134	146	156	132	141	153	163	137	145	159	169
			MBh	47.4	48.4	50.6	54.0	46.3	47.2	49.5	52.8	45.2	46.1	48.3	51.5	44.1	45.0	47.1	50.3	41.9	42.7	44.8	47.7	38.8	39.6	41.5	44.2
1500		S/T	1.00	0.97	0.88	0.71	1.00	1.00	0.91	0.74	1.00	1.00	0.93	0.76	1.00	1.00	0.96	0.78	1.00	1.00	0.96	0.81	1.00	1.00	0.96	0.82	
		ΔT	23	23	21	19	22	23	22	19	22	22	22	19	21	22	22	19	20	21	22	19	19	19	20	17	
85		1900	kW	3.32	3.39	3.49	3.59	3.56	3.63	3.74	3.85	3.77	3.85	3.96	4.09	3.95	4.04	4.16	4.29	4.11	4.20	4.33	4.47	4.25	4.34	4.47	4.62
			Amps	14.0	14.3	14.6	15.1	14.9	15.2	15.6	16.1	16.0	16.3	16.8	17.3	16.9	17.2	17.7	18.3	17.8	18.2	18.7	19.3	18.7	19.1	19.7	20.3
		1700	Hi PR	239	257	271	283	268	288	305	318	305	328	346	361	347	374	395	411	391	420	444	463	432	464	490	511
			Lo PR	113	121	132	140	120	127	139	148	125	133	145	154	131	139	152	162	137	146	159	170	142	151	165	175
	1500	MBh	46.7	47.6	49.9	53.2	45.7	46.5	48.7	52.0	44.6	45.4	47.6	50.8	43.5	44.3	46.4	49.5	41.3	42.1	44.1	47.0	38.3	39.0	40.8	43.6	
		S/T	0.96	0.93	0.84	0.68	1.00	0.96	0.87	0.71	1.00	0.99	0.89	0.72	1.00	1.00	0.92	0.75	1.00	1.00	0.96	0.78	1.00	1.00	0.96	0.78	
	85	1900	ΔT	24	24	23	20	25	24	23	20	24	24	23	20	24	24	23	20	24	24	23	20	21	21	21	18
			kW	3.31	3.37	3.47	3.57	3.54	3.61	3.72	3.83	3.75	3.83	3.94	4.06	3.93	4.01	4.14	4.27	4.09	4.17	4.30	4.44	4.22	4.31	4.45	4.59
		1700	Amps	13.9	14.2	14.6	15.0	14.8	15.1	15.5	16.0	15.9	16.2	16.7	17.2	16.8	17.2	17.6	18.2	17.7	18.1	18.6	19.2	18.6	19.0	19.6	20.2
			Hi PR	237	255	270	281	266	286	302	315	303	326	344	359	345	371	392	409	388	417	441	460	429	461	487	508
1500		Lo PR	113	120	131	139	119	127	138	147	124	132	144	153	130	138	151	161	136	145	158	168	141	150	164	174	
		MBh	44.4	45.3	47.4	50.6	43.4	44.2	46.3	49.4	42.3	43.2	45.2	48.2	41.3	42.1	44.1	47.0	39.2	40.0	41.9	44.7	36.3	37.1	38.8	41.4	
85		1900	S/T	0.92	0.89	0.80	0.65	0.96	0.92	0.83	0.68	0.98	0.95	0.85	0.69	1.00	0.98	0.88	0.72	1.00	1.00	0.92	0.74	1.00	1.00	0.92	0.75
			ΔT	25	25	23	20	25	25	24	20	25	25	24	20	25	25	24	21	24	25	24	20	22	23	22	19
		1700	kW	3.26	3.32	3.42	3.52	3.49	3.56	3.66	3.77	3.69	3.77	3.88	4.00	3.87	3.95	4.07	4.20	4.02	4.11	4.24	4.37	4.16	4.24	4.38	4.52
			Amps	13.7	14.0	14.3	14.8	14.6	14.9	15.3	15.8	15.6	16.0	16.4	16.9	16.5	16.9	17.4	17.9	17.4	17.8	18.3	18.9	18.3	18.7	19.3	19.9
	1500	Hi PR	232	250	264	276	261	281	296	309	297	319	337	352	338	364	384	400	380	409	432	451	420	452	477	498	
		Lo PR	110	117	128	137	117	124	135	144	121	129	141	150	127	135	148	157	133	142	155	165	138	147	160	171	

IDB: Entering Indoor Dry Bulb Temperature
 High & low pressures are measured at the liquid & suction access fittings.
 Shaded area reflects AHRI (TVA) conditions
 kW = Total system power
 Amps = outdoor unit amps (comp.+ fans)

EXPANDED COOLING DATA — GPH1549M41* — LOW STAGE

IDB	AIRFLOW	OUTDOOR AMBIENT TEMPERATURE												ENTERING INDOOR WET BULB TEMPERATURE																																			
		65°F				75°F				85°F				95°F				105°F				115°F																											
		59	63	67	71	59	63	67	71	59	63	67	71	59	63	67	71	59	63	67	71	59	63	67	71																								
70	1350	33.4	34.6	37.9	-	32.6	33.8	37.0	-	31.8	33.0	36.1	-	31.0	32.2	35.2	-	29.5	30.6	33.5	-	27.3	28.3	31.0	-	0.76	0.64	0.44	-	0.79	0.66	0.46	-	0.81	0.68	0.47	-	0.84	0.70	0.48	-	0.87	0.73	0.50	-	0.88	0.73	0.51	-
		1.7	1.5	1.1	-	1.8	1.5	1.2	-	1.8	1.5	1.2	-	1.8	1.5	1.2	-	1.7	1.5	1.1	-	1.6	1.4	1.1	-	2.16	2.21	2.27	-	2.32	2.37	2.44	-	2.46	2.51	2.59	-	2.58	2.64	2.72	-	2.69	2.74	2.83	-	2.78	2.84	2.93	-
		9.3	9.5	9.7	-	9.9	10.1	10.4	-	10.6	10.8	11.2	-	11.2	11.5	11.8	-	11.9	12.1	12.5	-	12.5	12.7	13.1	-	217	233	247	-	243	262	277	-	277	298	315	-	315	339	358	-	355	382	403	-	392	422	445	-
		113	120	131	-	119	127	139	-	124	132	144	-	130	139	151	-	137	145	159	-	141	150	164	-	32.4	33.6	36.8	-	31.6	32.8	35.9	-	30.9	32.0	35.1	-	30.1	31.2	34.2	-	28.6	29.7	32.5	-	26.5	27.5	30.1	-
		0.73	0.61	0.42	-	0.75	0.63	0.44	-	0.77	0.65	0.45	-	0.80	0.67	0.46	-	0.83	0.69	0.48	-	0.84	0.70	0.48	-	18	16	12	-	18	16	12	-	18	16	12	-	18	16	12	-	17	15	11	-				
		2.15	2.19	2.26	-	2.30	2.35	2.42	-	2.44	2.49	2.57	-	2.56	2.62	2.70	-	2.67	2.72	2.81	-	2.75	2.81	2.90	-	9.2	9.4	9.7	-	9.9	10.0	10.3	-	10.6	10.8	11.1	-	11.2	11.4	11.7	-	11.8	12.0	12.4	-				
		2.10	2.14	2.20	-	2.25	2.30	2.37	-	2.38	2.43	2.51	-	2.50	2.55	2.63	-	2.60	2.66	2.74	-	2.69	2.74	2.83	-	9.0	9.2	9.5	-	9.6	9.8	10.1	-	10.3	10.5	10.8	-	10.9	11.1	11.4	-	11.5	11.7	12.1	-				
		208	224	237	-	234	252	266	-	266	286	302	-	303	326	344	-	341	367	387	-	376	405	428	-	109	116	126	-	115	122	133	-	119	127	138	-	125	133	145	-	131	140	152	-				
		109	116	126	-	115	122	133	-	119	127	138	-	125	133	145	-	131	140	152	-	136	144	158	-																								

75	1350	33.9	34.9	37.8	40.6	33.1	34.1	36.9	39.6	32.4	33.3	36.1	38.7	31.6	32.5	35.2	37.8	30.0	30.9	33.4	35.9	27.8	28.6	31.0	33.2	0.87	0.78	0.59	0.38	0.90	0.80	0.61	0.39	0.92	0.82	0.62	0.40	0.95	0.85	0.64	0.41	0.99	0.88	0.67	0.43	1.00	0.89	0.67	0.43				
		20	18	15	10	20	19	15	11	20	19	15	11	20	19	15	11	20	19	15	11	20	19	15	11	20	19	15	10	2.18	2.22	2.29	2.36	2.34	2.39	2.46	2.54	2.48	2.53	2.61	2.69	2.60	2.66	2.74	2.83	2.71	2.77	2.85	2.95	2.80	2.86	2.95	3.05
		9.4	9.6	9.8	10.1	10.0	10.2	10.5	10.8	10.7	10.9	11.2	11.6	11.3	11.6	11.9	12.3	12.0	12.2	12.6	13.0	12.6	12.8	13.2	13.6	219	236	249	260	246	265	279	291	280	301	318	331	319	343	362	378	358	386	407	425	396	426	450	469				
		114	121	133	141	121	128	140	149	125	133	146	155	132	140	153	163	138	147	160	171	143	152	166	177	32.9	33.9	36.7	39.4	32.2	33.1	35.9	38.5	31.4	32.3	35.0	37.6	30.6	31.6	34.2	36.7	29.1	30.0	32.4	34.8	27.0	27.8	30.1	32.3				
		0.83	0.74	0.56	0.36	0.86	0.77	0.58	0.37	0.88	0.79	0.60	0.38	0.91	0.81	0.61	0.40	0.94	0.84	0.64	0.41	0.95	0.85	0.64	0.41	21	19	16	11	21	19	16	11	21	19	16	11	21	19	16	11	21	19	16	11	20	18	15	10				
		2.16	2.21	2.27	2.34	2.32	2.37	2.44	2.52	2.46	2.51	2.59	2.67	2.58	2.64	2.72	2.81	2.69	2.74	2.83	2.92	2.78	2.84	2.93	3.02	9.3	9.5	9.7	10.0	9.9	10.1	10.4	10.7	10.6	10.9	11.2	11.5	11.2	11.5	11.8	12.2	11.9	12.1	12.5	12.9	12.5	12.7	13.1	13.5				
		217	233	247	257	243	262	277	289	277	298	315	328	315	339	358	374	355	382	403	421	392	422	445	465	113	120	131	140	119	127	139	148	124	132	144	154	130	139	151	161	137	145	159	169	141	150	164	175				
		30.4	31.3	33.9	36.4	29.7	30.6	33.1	35.5	29.0	29.9	32.3	34.7	28.3	29.1	31.5	33.8	26.9	27.7	29.9	32.1	24.9	25.6	27.7	29.8	0.80	0.71	0.54	0.35	0.83	0.74	0.56	0.36	0.85	0.76	0.57	0.37	0.88	0.78	0.59	0.38	0.91	0.81	0.62	0.40	0.92	0.82	0.62	0.40				
		21	20	16	11	22	20	16	11	22	20	16	11	22	20	16	11	22	20	16	11	21	20	16	11	21	20	16	11	2.11	2.16	2.22	2.29	2.27	2.31	2.38	2.46	2.40	2.45	2.53	2.61	2.52	2.57	2.65	2.74	2.62	2.68	2.76	2.85	2.71	2.77	2.86	2.95
		9.1	9.3	9.5	9.8	9.7	9.9	10.2	10.5	10.4	10.6	10.9	11.2	11.0	11.2	11.5	11.9	11.6	11.8	12.2	12.6	12.2	12.4	12.8	13.2	210	226	239	249	236	254	268	280	269	289	305	318	306	329	348	363	344	370	391	408	380	409	432	451				
	110	117	127	136	116	123	135	143	120	128	140	149	127	135	147	156	133	141	154	164	137	146	159	170																													

IDB: Entering Indoor Dry Bulb Temperature
 High & low pressures are measured at the liquid & suction access fittings.

Shaded area reflects ACCA (TVA) conditions

kW = Total system power
 Amps = outdoor unit amps (comp.+ fans)

EXPANDED COOLING DATA — GPH1549M41* — LOW STAGE (CONT.)

IDB	AIRFLOW	OUTDOOR AMBIENT TEMPERATURE												ENTERING INDOOR WET BULB TEMPERATURE												
		65°F				75°F				85°F				95°F				105°F				115°F				
		59	63	67	71	59	63	67	71	59	63	67	71	59	63	67	71	59	63	67	71	59	63	67	71	
80	1350	MBh	34.5	35.3	37.7	40.3	33.7	34.5	36.8	39.4	32.9	33.6	35.9	38.4	32.1	32.8	35.1	37.5	30.5	31.2	33.3	35.6	28.3	28.9	30.9	33.0
		S/T	0.95	0.89	0.73	0.54	1.00	0.93	0.75	0.56	1.00	0.95	0.77	0.58	1.00	1.00	0.80	0.60	1.00	1.00	0.83	0.62	1.00	1.00	0.83	0.62
	ΔT	22	21	19	15	23	22	19	15	22	22	19	15	22	22	19	15	21	21	19	15	19	20	18	14	
	kW	2.20	2.24	2.31	2.38	2.36	2.41	2.48	2.56	2.50	2.55	2.63	2.71	2.62	2.68	2.76	2.85	2.73	2.79	2.88	2.97	2.82	2.88	2.98	3.07	
	Amps	9.5	9.6	9.9	10.2	10.1	10.3	10.6	10.9	10.8	11.0	11.3	11.7	11.4	11.7	12.0	12.4	12.0	12.3	12.7	13.1	12.7	12.9	13.3	13.8	
	Hi PR	221	238	252	262	248	267	282	294	282	304	321	335	322	346	366	381	362	390	411	429	400	430	454	474	
	Lo PR	115	123	134	143	122	130	142	151	127	135	147	157	133	142	155	165	139	148	162	172	144	153	168	178	
	MBh	33.5	34.3	36.6	39.1	32.7	33.5	35.8	38.2	32.0	32.7	34.9	37.3	31.2	31.9	34.1	36.4	29.6	30.3	32.3	34.6	27.4	28.0	30.0	32.0	
	S/T	0.91	0.85	0.69	0.52	0.94	0.88	0.72	0.54	0.96	0.90	0.74	0.55	1.00	0.93	0.76	0.57	1.00	0.97	0.79	0.59	1.00	0.98	0.80	0.59	
	ΔT	23	22	19	16	24	23	20	16	24	23	20	16	24	23	20	16	23	22	20	16	21	21	18	15	
1200	1350	MBh	2.18	2.22	2.29	2.36	2.34	2.39	2.46	2.54	2.48	2.53	2.61	2.69	2.60	2.66	2.74	2.83	2.71	2.77	2.85	2.95	2.80	2.86	2.95	3.05
		Amps	9.4	9.6	9.8	10.1	10.0	10.2	10.5	10.8	10.7	10.9	11.2	11.6	11.3	11.6	11.9	12.3	12.0	12.2	12.6	13.0	12.6	12.8	13.2	13.6
	Hi PR	219	236	249	260	246	265	279	291	280	301	318	332	319	343	362	378	358	386	407	425	396	426	450	469	
	Lo PR	114	122	133	141	121	128	140	149	125	133	146	155	132	140	153	163	138	147	160	171	143	152	166	177	
	MBh	30.9	31.6	33.8	36.1	30.2	30.9	33.0	35.3	29.5	30.2	32.2	34.4	28.8	29.4	31.4	33.6	27.3	27.9	29.9	31.9	25.3	25.9	27.7	29.6	
	S/T	0.88	0.82	0.67	0.50	0.91	0.85	0.69	0.52	0.93	0.87	0.71	0.53	0.96	0.90	0.73	0.55	1.00	0.93	0.76	0.57	1.00	0.94	0.77	0.57	
	ΔT	24	23	20	16	24	23	20	16	24	23	20	16	24	23	20	16	24	23	20	16	22	21	19	15	
	kW	2.13	2.17	2.24	2.31	2.28	2.33	2.40	2.48	2.42	2.47	2.55	2.63	2.54	2.59	2.68	2.76	2.64	2.70	2.78	2.87	2.73	2.79	2.88	2.97	
	Amps	9.2	9.4	9.6	9.9	9.8	10.0	10.2	10.6	10.5	10.7	11.0	11.3	11.1	11.3	11.6	12.0	11.7	11.9	12.3	12.7	12.3	12.5	12.9	13.3	
	Hi PR	213	229	242	252	239	257	271	283	271	292	308	322	309	333	351	366	348	374	395	412	384	413	436	455	
Lo PR	111	118	129	137	117	125	136	145	122	129	141	150	128	136	148	158	134	142	156	166	139	147	161	171		

1350	1350	MBh	35.1	35.8	37.5	40.0	34.3	35.0	36.6	39.1	33.5	34.2	35.8	38.2	32.7	33.3	34.9	37.2	31.1	31.7	33.2	35.4	28.8	29.3	30.7	32.8
		S/T	1.00	0.96	0.87	0.70	1.00	1.00	0.90	0.73	1.00	1.00	0.92	0.75	1.00	1.00	0.95	0.77	1.00	1.00	0.99	0.80	1.00	1.00	1.00	0.81
	ΔT	24	23	22	19	23	24	22	19	23	23	22	19	22	23	23	20	21	22	22	19	20	20	21	18	
	kW	2.21	2.26	2.33	2.40	2.38	2.42	2.50	2.58	2.52	2.57	2.65	2.74	2.64	2.70	2.79	2.88	2.75	2.81	2.90	3.00	2.84	2.91	3.00	3.10	
	Amps	9.5	9.7	10.0	10.3	10.2	10.4	10.6	11.0	10.9	11.1	11.4	11.8	11.5	11.8	12.1	12.5	12.1	12.4	12.8	13.2	12.8	13.0	13.4	13.9	
	Hi PR	224	241	254	265	251	270	285	297	285	307	324	338	325	350	369	385	366	393	415	433	404	435	459	479	
	Lo PR	117	124	135	144	123	131	143	152	128	136	149	158	134	143	156	166	141	150	164	174	146	155	169	180	
	MBh	34.1	34.8	36.4	38.9	33.3	34.0	35.6	38.0	32.5	33.2	34.7	37.0	31.7	32.3	33.9	36.1	30.1	30.7	32.2	34.3	27.9	28.5	29.8	31.8	
	S/T	0.95	0.92	0.83	0.67	0.99	0.95	0.86	0.70	1.00	0.98	0.88	0.71	1.00	1.00	0.91	0.74	1.00	1.00	0.94	0.77	1.00	1.00	0.95	0.77	
	ΔT	25	24	23	20	25	25	23	20	25	25	23	20	24	25	24	20	23	24	23	20	21	22	22	19	
1200	1200	kW	2.20	2.24	2.31	2.38	2.36	2.41	2.48	2.56	2.50	2.55	2.63	2.71	2.62	2.68	2.76	2.85	2.73	2.79	2.88	2.97	2.82	2.88	2.98	3.07
		Amps	9.5	9.6	9.9	10.2	10.1	10.3	10.6	10.9	10.8	11.0	11.3	11.7	11.4	11.7	12.0	12.4	12.0	12.3	12.7	13.1	12.7	12.9	13.3	13.8
	Hi PR	221	238	252	262	248	267	282	294	282	304	321	335	322	346	366	381	362	390	411	429	400	430	454	474	
	Lo PR	115	123	134	143	122	130	142	151	127	135	147	157	133	142	155	165	139	148	162	172	144	153	168	178	
	MBh	31.5	32.1	33.6	35.9	30.8	31.4	32.8	35.0	30.0	30.6	32.1	34.2	29.3	29.9	31.3	33.4	27.8	28.4	29.7	31.7	25.8	26.3	27.5	29.4	
	S/T	0.92	0.89	0.80	0.65	0.95	0.92	0.83	0.67	0.98	0.94	0.85	0.69	1.00	0.97	0.88	0.71	1.00	1.00	0.91	0.74	1.00	1.00	0.92	0.74	
	ΔT	25	25	24	20	26	25	24	21	26	25	24	21	26	25	24	21	24	25	24	20	23	23	22	19	
	kW	2.15	2.19	2.25	2.32	2.30	2.35	2.42	2.50	2.44	2.49	2.57	2.65	2.56	2.62	2.70	2.78	2.66	2.72	2.81	2.90	2.75	2.81	2.90	3.00	
	Amps	9.2	9.4	9.7	10.0	9.8	10.0	10.3	10.6	10.6	10.8	11.1	11.4	11.2	11.4	11.7	12.1	11.8	12.0	12.4	12.8	12.4	12.6	13.0	13.4	
	Hi PR	215	231	244	254	241	259	274	286	274	295	311	325	312	336	355	370	351	378	399	416	388	417	441	460	
Lo PR	112	119	130	138	118	126	137	146	123	131	143	152	129	137	150	160	135	144	157	167	140	149	162	173		

IDB: Entering Indoor Dry Bulb Temperature
 High & low pressures are measured at the liquid & suction access fittings.
 Shaded area reflects AHRH (TVA) conditions
 kW = Total system power
 Amps = outdoor unit amps (comp.+ fans)

EXPANDED COOLING DATA — GPH1549M41* — HIGH STAGE

IDB	AIRFLOW	OUTDOOR AMBIENT TEMPERATURE												ENTERING INDOOR WET BULB TEMPERATURE													
		65°F				75°F				85°F				95°F				105°F				115°F					
		59	63	67	71	59	63	67	71	59	63	67	71	59	63	67	71	59	63	67	71	59	63	67	71		
70	1517	MBh	44.8	46.4	50.9	-	43.8	45.4	49.7	-	42.7	44.3	48.5	-	41.7	43.2	47.3	-	39.6	41.0	45.0	-	36.7	38.0	41.7	-	
		S/T	0.68	0.57	0.39	-	0.71	0.59	0.41	-	0.72	0.60	0.42	-	0.75	0.62	0.43	-	0.78	0.65	0.45	-	0.78	0.65	0.45	-	
		ΔT	19	16	12	-	19	16	12	-	19	16	12	-	19	16	12	-	19	16	12	-	17	15	11	-	
	1345	kW	3.05	3.12	3.22	-	3.29	3.36	3.47	-	3.50	3.58	3.69	-	3.68	3.77	3.89	-	3.84	3.93	4.06	-	3.98	4.07	4.20	-	
		Amps	13.3	13.5	13.9	-	14.2	14.5	14.9	-	15.2	15.6	16.0	-	16.2	16.5	17.0	-	17.1	17.4	18.0	-	18.0	18.4	18.9	-	
		Hi PR	227	244	258	-	254	274	289	-	289	311	329	-	330	355	374	-	371	399	421	-	410	441	465	-	
	1183	Lo PR	107	114	124	-	113	120	131	-	118	125	137	-	124	131	144	-	130	138	150	-	134	143	156	-	
		MBh	43.5	45.1	49.4	-	42.5	44.0	48.3	-	41.5	43.0	47.1	-	40.5	41.9	46.0	-	38.4	39.8	43.7	-	35.6	36.9	40.4	-	
		S/T	0.65	0.54	0.38	-	0.67	0.56	0.39	-	0.69	0.58	0.40	-	0.71	0.60	0.41	-	0.74	0.62	0.43	-	0.75	0.62	0.43	-	
	75	1517	ΔT	19	17	13	-	20	17	13	-	20	17	13	-	20	17	13	-	19	17	13	-	18	16	12	-
			kW	3.03	3.09	3.19	-	3.26	3.33	3.44	-	3.47	3.55	3.66	-	3.65	3.73	3.86	-	3.81	3.89	4.02	-	3.94	4.03	4.17	-
			Amps	13.2	13.4	13.8	-	14.1	14.4	14.8	-	15.1	15.4	15.9	-	16.0	16.4	16.9	-	16.9	17.3	17.8	-	17.8	18.2	18.8	-
1345		Hi PR	224	242	255	-	252	271	286	-	286	308	326	-	326	351	371	-	367	395	417	-	406	436	461	-	
		Lo PR	106	113	123	-	112	119	130	-	116	124	135	-	122	130	142	-	128	136	149	-	133	141	154	-	
		MBh	40.2	41.6	45.6	-	39.2	40.7	44.5	-	38.3	39.7	43.5	-	37.4	38.7	42.4	-	35.5	36.8	40.3	-	32.9	34.1	37.3	-	
1183		S/T	0.63	0.52	0.36	-	0.65	0.54	0.38	-	0.67	0.56	0.39	-	0.69	0.57	0.40	-	0.71	0.60	0.41	-	0.72	0.60	0.42	-	
		ΔT	20	17	13	-	20	17	13	-	20	17	13	-	20	17	13	-	20	17	13	-	18	16	12	-	
		kW	2.96	3.02	3.11	-	3.18	3.25	3.36	-	3.38	3.46	3.57	-	3.56	3.64	3.76	-	3.71	3.79	3.92	-	3.84	3.93	4.06	-	
75		1517	Amps	12.9	13.1	13.5	-	13.7	14.0	14.4	-	14.8	15.1	15.5	-	15.6	16.0	16.4	-	16.5	16.9	17.4	-	17.4	17.8	18.3	-
			Hi PR	218	234	247	-	244	263	278	-	278	299	316	-	316	341	360	-	356	383	405	-	393	423	447	-
			Lo PR	103	109	120	-	109	116	126	-	113	120	131	-	119	126	138	-	124	132	144	-	129	137	149	-
75	1517	MBh	45.6	46.9	50.8	54.5	44.5	45.8	49.6	53.2	43.5	44.7	48.4	52.0	42.4	43.6	47.2	50.7	40.3	41.5	44.9	48.2	37.3	38.4	41.6	44.6	
		S/T	0.77	0.69	0.52	0.34	0.80	0.72	0.54	0.35	0.82	0.74	0.56	0.36	0.85	0.76	0.58	0.37	0.88	0.79	0.60	0.38	0.89	0.80	0.60	0.39	
		ΔT	21	20	16	11	22	20	16	11	22	20	16	11	22	20	16	11	22	20	16	11	20	19	15	10	
	1345	kW	3.08	3.14	3.24	3.35	3.32	3.39	3.50	3.61	3.53	3.61	3.72	3.85	3.71	3.80	3.92	4.06	3.87	3.96	4.09	4.23	4.01	4.10	4.24	4.38	
		Amps	13.4	13.7	14.0	14.5	14.3	14.6	15.0	15.5	15.4	15.7	16.2	16.7	16.3	16.6	17.1	17.7	17.2	17.6	18.1	18.7	18.1	18.5	19.1	19.7	
		Hi PR	229	246	260	271	257	277	292	305	292	315	332	346	333	358	378	395	374	403	426	444	414	445	470	490	
	1183	Lo PR	108	115	126	134	114	122	133	141	119	126	138	147	125	133	145	154	131	139	152	162	135	144	157	167	
		MBh	44.2	45.6	49.3	52.9	43.2	44.5	48.2	51.7	42.2	43.4	47.0	50.5	41.2	42.4	45.9	49.2	39.1	40.3	43.6	46.8	36.2	37.3	40.4	43.3	
		S/T	0.74	0.66	0.50	0.32	0.77	0.68	0.52	0.33	0.79	0.70	0.53	0.34	0.81	0.73	0.55	0.35	0.84	0.75	0.57	0.37	0.85	0.76	0.57	0.37	
	75	1517	ΔT	22	21	17	12	23	21	17	12	23	21	17	12	23	21	17	12	22	21	17	12	21	19	16	11
			kW	3.05	3.12	3.22	3.32	3.29	3.36	3.47	3.58	3.50	3.58	3.69	3.82	3.68	3.77	3.89	4.02	3.84	3.93	4.06	4.20	3.98	4.07	4.20	4.35
			Amps	13.3	13.5	13.9	14.4	14.2	14.5	14.9	15.4	15.2	15.6	16.0	16.6	16.2	16.5	17.0	17.6	17.1	17.5	18.0	18.6	18.0	18.4	18.9	19.6
1345		Hi PR	227	244	258	269	254	274	289	302	289	311	329	343	330	355	375	391	371	399	421	439	410	441	466	486	
		Lo PR	107	114	124	133	113	120	131	140	118	125	137	146	124	131	144	153	130	138	150	160	134	143	156	166	
		MBh	40.8	42.0	45.5	48.8	39.9	41.1	44.5	47.7	38.9	40.1	43.4	46.6	38.0	39.1	42.3	45.4	36.1	37.2	40.2	43.2	33.4	34.4	37.3	40.0	
1183		S/T	0.71	0.64	0.48	0.31	0.74	0.66	0.50	0.32	0.76	0.68	0.51	0.33	0.78	0.70	0.53	0.34	0.81	0.73	0.55	0.35	0.82	0.73	0.55	0.36	
		ΔT	23	21	17	12	23	21	17	12	23	21	17	12	23	21	17	12	23	21	17	12	21	20	16	11	
		kW	2.98	3.04	3.14	3.24	3.21	3.28	3.38	3.50	3.41	3.49	3.60	3.72	3.59	3.67	3.79	3.92	3.74	3.83	3.95	4.09	3.88	3.96	4.10	4.23	
75		1517	Amps	13.0	13.2	13.6	14.0	13.9	14.1	14.5	15.0	14.9	15.2	15.6	16.2	15.8	16.1	16.6	17.1	16.7	17.0	17.5	18.1	17.5	17.9	18.5	19.1
			Hi PR	220	237	250	261	247	266	280	293	281	302	319	333	320	344	363	379	360	387	409	426	397	428	452	471
			Lo PR	104	111	121	129	110	117	128	136	114	121	133	141	120	128	139	148	126	134	146	155	130	138	151	161

IDB: Entering Indoor Dry Bulb Temperature
 High & low pressures are measured at the liquid & suction access fittings.
 Shaded area reflects ACCA (TVA) conditions
 kW = Total system power
 Amps = outdoor unit amps (comp.+ fans)

EXPANDED COOLING DATA — GPH1549M41* — HIGH STAGE (CONT.)

IDB	OUTDOOR AMBIENT TEMPERATURE																																																				
	65°F					75°F					85°F					95°F					105°F					115°F																											
	59	63	67	71	75	59	63	67	71	75	59	63	67	71	75	59	63	67	71	75	59	63	67	71	75	59	63	67	71	75																							
1517	MBh	46.4	47.4	50.6	54.1	45.3	46.3	49.5	52.9	44.2	45.2	48.3	51.6	43.1	44.1	47.1	50.4	41.0	41.9	44.7	47.8	38.0	38.8	41.4	44.3	0.85	0.80	0.65	0.48	0.88	0.83	0.67	0.50	0.90	0.85	0.69	0.52	0.93	0.87	0.71	0.53	0.97	0.91	0.74	0.55	1.00	0.92	0.74	0.56				
	ΔT	24	23	20	16	24	23	20	16	24	23	20	16	24	23	20	16	24	23	20	16	24	23	20	16	23	22	19	15	3.10	3.17	3.27	3.38	3.34	3.42	3.53	3.65	3.56	3.64	3.76	3.88	3.75	3.83	3.96	4.09	3.91	3.99	4.13	4.27	4.04	4.14	4.28	4.42
	kW	13.5	13.8	14.1	14.6	14.4	14.7	15.1	15.6	15.5	15.8	16.3	16.8	16.4	16.8	17.3	17.9	17.4	17.7	18.3	18.9	18.3	18.7	19.3	19.9	231	249	263	274	260	279	295	308	295	318	335	350	336	362	382	399	378	407	430	448	418	450	475	495				
	Hi PR	109	116	127	135	116	123	134	143	120	128	139	148	126	134	146	156	132	141	153	163	137	145	159	169	45.0	46.0	49.2	52.6	44.0	44.9	48.0	51.3	42.9	43.9	46.9	50.1	41.9	42.8	45.7	48.9	39.8	40.7	43.4	46.4	36.9	37.7	40.2	43.0				
	Lo PR	0.81	0.76	0.62	0.46	0.84	0.79	0.64	0.48	0.86	0.81	0.66	0.49	0.89	0.83	0.68	0.51	0.92	0.87	0.70	0.53	0.93	0.87	0.71	0.53	25	24	21	17	25	24	21	17	25	24	21	17	25	24	21	17	25	24	21	17	23	22	20	16	12	10	8	6
	ΔT	3.08	3.14	3.24	3.35	3.32	3.39	3.50	3.61	3.53	3.61	3.72	3.85	3.71	3.80	3.92	4.06	3.87	3.96	4.09	4.23	4.01	4.10	4.24	4.38	13.4	13.7	14.0	14.5	14.3	14.6	15.0	15.5	15.4	15.7	16.2	16.7	16.3	16.6	17.1	17.7	17.2	17.6	18.1	18.7	18.1	18.5	19.1	19.7				
	Amps	229	246	260	271	257	277	292	305	292	315	332	346	333	358	378	395	375	403	426	444	414	445	470	490	108	115	126	134	114	122	133	141	119	126	138	147	125	133	145	154	131	139	152	162	135	144	157	167				
	Lo PR	41.6	42.5	45.4	48.5	40.6	41.5	44.3	47.4	39.6	40.5	43.3	46.2	38.7	39.5	42.2	45.1	36.7	37.5	40.1	42.9	34.0	34.8	37.1	39.7	0.78	0.73	0.60	0.45	0.81	0.76	0.62	0.46	0.83	0.78	0.63	0.47	0.86	0.80	0.65	0.49	0.89	0.83	0.68	0.51	0.90	0.84	0.68	0.51				
	ΔT	25	24	21	17	26	24	21	17	26	25	21	17	26	25	21	17	26	25	21	17	24	23	20	16	3.00	3.07	3.16	3.27	3.24	3.31	3.41	3.52	3.44	3.52	3.63	3.75	3.62	3.70	3.82	3.95	3.78	3.86	3.99	4.12	3.91	4.00	4.13	4.27				
	Lo PR	13.1	13.3	13.7	14.1	14.0	14.3	14.7	15.1	15.0	15.3	15.8	16.3	15.9	16.2	16.7	17.3	16.8	17.2	17.7	18.3	17.7	18.1	18.6	19.2	222	239	252	263	249	268	283	295	284	305	322	336	323	348	367	383	363	391	413	431	401	432	456	476				
Lo PR	105	112	122	130	111	118	129	137	115	123	134	143	121	129	141	150	127	135	147	157	131	140	152	162																													

IDB	OUTDOOR AMBIENT TEMPERATURE																																																
	65°F					75°F					85°F					95°F					105°F					115°F																							
	59	63	67	71	75	59	63	67	71	75	59	63	67	71	75	59	63	67	71	75	59	63	67	71	75	59	63	67	71	75																			
1517	MBh	47.2	48.1	50.4	53.7	46.1	47.0	49.2	52.5	45.0	45.9	48.0	51.2	43.9	44.7	46.9	50.0	41.7	42.5	44.5	47.5	38.6	39.4	41.2	44.0	0.89	0.86	0.78	0.63	0.92	0.89	0.80	0.65	0.95	0.91	0.82	0.67	0.98	0.94	0.85	0.69	1.00	0.98	0.88	0.72	1.00	0.99	0.89	0.72
	ΔT	25	25	24	21	26	25	24	21	26	25	24	21	26	25	24	21	26	25	24	21	23	24	22	19	3.13	3.19	3.30	3.40	3.37	3.45	3.56	3.68	3.59	3.67	3.79	3.91	3.78	3.86	3.99	4.13	3.94	4.03	4.16	4.31	4.08	4.17	4.31	4.46
	kW	13.6	13.9	14.3	14.7	14.5	14.8	15.3	15.8	15.6	16.0	16.4	17.0	16.6	16.9	17.4	18.0	17.5	17.9	18.4	19.1	18.4	18.8	19.4	20.1	234	251	266	277	262	282	298	311	298	321	339	353	340	365	386	402	382	411	434	453	422	454	480	500
	Hi PR	110	117	128	137	117	124	135	144	121	129	141	150	127	135	148	158	133	142	155	165	138	147	160	171	45.8	46.7	48.9	52.2	44.8	45.6	47.8	51.0	43.7	44.5	46.6	49.8	42.6	43.4	45.5	48.5	40.5	41.3	43.2	46.1	37.5	38.2	40.0	42.7
	Lo PR	0.85	0.82	0.74	0.60	0.88	0.85	0.77	0.62	0.90	0.87	0.79	0.64	0.93	0.90	0.81	0.66	0.97	0.93	0.84	0.68	0.98	0.94	0.85	0.69	27	26	25	21	27	26	25	22	27	27	25	22	27	27	25	22	27	26	25	22	25	25	23	20
	ΔT	3.10	3.17	3.27	3.38	3.34	3.42	3.53	3.65	3.56	3.64	3.76	3.88	3.75	3.83	3.96	4.09	3.91	3.99	4.13	4.27	4.04	4.14	4.28	4.42	13.5	13.8	14.1	14.6	14.4	14.7	15.1	15.6	15.5	15.8	16.3	16.8	16.4	16.8	17.3	17.9	17.4	17.7	18.3	18.9	18.3	18.7	19.3	19.9
	Amps	231	249	263	274	260	279	295	308	295	318	335	350	336	362	382	399	378	407	430	448	418	450	475	495	109	116	127	135	116	123	134	143	120	128	139	148	126	134	146	156	132	141	153	163	137	145	159	169
	Lo PR	42.3	43.1	45.1	48.2	41.3	42.1	44.1	47.0	40.3	41.1	43.0	45.9	39.3	40.1	42.0	44.8	37.4	38.1	39.9	42.6	34.6	35.3	37.0	39.4	0.82	0.79	0.71	0.58	0.85	0.82	0.74	0.60	0.87	0.84	0.76	0.62	0.90	0.87	0.78	0.63	0.93	0.90	0.81	0.66	0.94	0.91	0.82	0.66
	ΔT	27	26	25	22	27	27	25	22	27	27	25	22	27	27	25	22	27	27	25	22	25	25	24	20	3.03	3.09	3.19	3.29	3.26	3.33	3.44	3.55	3.47	3.55	3.66	3.78	3.65	3.73	3.86	3.99	3.81	3.89	4.02	4.16	3.94	4.03	4.17	4.31
	Lo PR	13.2	13.4	13.8	14.3	14.1	14.4	14.8	15.3	15.1	15.4	15.9	16.4	16.0	16.4	16.9	17.4	16.9	17.3	17.8	18.4	17.8	18.2	18.8	19.4	224	241	255	266	252	271	286	298	286	308	325	339	326	351	371	387	367	395	417	435	405	436	461	480
Lo PR	106	113	123	131	112	119	130	139	116	124	135	144	122	130	142	151	128	136	149	159	133	141	154	164																									

kW = Total system power
Amps = outdoor unit amps (comp.+ fans)

Shaded area reflects AHRI (TVA) conditions

IDB: Entering Indoor Dry Bulb Temperature
High & low pressures are measured at the liquid & suction access fittings.

EXPANDED COOLING DATA — GPH1560M41* — LOW STAGE

IDB	AIRFLOW	OUTDOOR AMBIENT TEMPERATURE																							
		65°F				75°F				85°F				95°F				105°F				115°F			
		59	63	67	71	59	63	67	71	59	63	67	71	59	63	67	71	59	63	67	71	59	63	67	71
	MBh	39.6	41.1	45.0	-	38.7	40.1	43.9	-	37.8	39.2	42.9	-	36.9	38.2	41.9	-	35.0	36.3	39.8	-	32.4	33.6	36.8	-
	S/T	0.73	0.61	0.42	-	0.76	0.63	0.44	-	0.78	0.65	0.45	-	0.80	0.67	0.47	-	0.83	0.70	0.48	-	0.84	0.70	0.49	-
	DT	18	15	12	-	18	15	12	-	18	15	12	-	18	16	12	-	18	15	12	-	17	14	11	-
1519	kW	2.79	2.85	2.93	-	3.00	3.06	3.16	-	3.18	3.25	3.35	-	3.34	3.42	3.53	-	3.48	3.56	3.67	-	3.60	3.68	3.80	-
	Amps	12.3	12.5	12.9	-	13.1	13.4	13.8	-	14.1	14.4	14.9	-	15.0	15.3	15.8	-	15.8	16.2	16.7	-	16.7	17.1	17.6	-
	Hi PR	222	239	252	-	249	268	283	-	283	305	322	-	322	347	366	-	363	390	412	-	401	431	455	-
	Lo PR	109	116	127	-	116	123	134	-	120	128	139	-	126	134	146	-	132	141	154	-	137	145	159	-
	MBh	38.5	39.9	43.7	-	37.6	38.9	42.7	-	36.7	38.0	41.6	-	35.8	37.1	40.6	-	34.0	35.2	38.6	-	31.5	32.6	35.8	-
	S/T	0.70	0.58	0.40	-	0.72	0.61	0.42	-	0.74	0.62	0.43	-	0.77	0.64	0.44	-	0.80	0.66	0.46	-	0.80	0.67	0.46	-
	DT	18	16	12	-	19	16	12	-	19	16	12	-	19	16	12	-	18	16	12	-	17	15	11	-
70	kW	2.77	2.82	2.91	-	2.97	3.04	3.13	-	3.16	3.22	3.33	-	3.32	3.39	3.50	-	3.45	3.53	3.64	-	3.57	3.65	3.77	-
	Amps	12.2	12.5	12.8	-	13.0	13.3	13.7	-	14.0	14.3	14.7	-	14.9	15.2	15.6	-	15.7	16.1	16.5	-	16.5	16.9	17.4	-
	Hi PR	220	236	250	-	246	265	280	-	280	302	318	-	319	343	363	-	359	386	408	-	397	427	451	-
	Lo PR	108	115	126	-	114	122	133	-	119	126	138	-	125	133	145	-	131	139	152	-	135	144	157	-
	MBh	35.5	36.8	40.3	-	34.7	35.9	39.4	-	33.9	35.1	38.4	-	33.0	34.2	37.5	-	31.4	32.5	35.6	-	29.1	30.1	33.0	-
	S/T	0.67	0.56	0.39	-	0.70	0.58	0.40	-	0.72	0.60	0.41	-	0.74	0.62	0.43	-	0.77	0.64	0.44	-	0.77	0.65	0.45	-
	DT	19	16	12	-	19	16	12	-	19	16	12	-	19	16	12	-	19	16	12	-	18	15	12	-
1181	kW	2.70	2.76	2.84	-	2.90	2.96	3.06	-	3.08	3.15	3.25	-	3.24	3.31	3.41	-	3.37	3.44	3.55	-	3.48	3.56	3.68	-
	Amps	11.9	12.2	12.5	-	12.7	13.0	13.4	-	13.7	14.0	14.4	-	14.5	14.8	15.3	-	15.3	15.7	16.1	-	16.1	16.5	17.0	-
	Hi PR	213	229	242	-	239	257	272	-	272	293	309	-	310	333	352	-	348	375	396	-	385	414	437	-
	Lo PR	105	112	122	-	111	118	129	-	115	123	134	-	121	129	141	-	127	135	147	-	131	140	153	-

	MBh	40.3	41.5	44.9	48.2	39.4	40.5	43.9	47.1	38.4	39.6	42.8	45.9	37.5	38.6	41.8	44.8	35.6	36.7	39.7	42.6	33.0	34.0	36.8	39.4
	S/T	0.83	0.75	0.56	0.36	0.86	0.77	0.58	0.38	0.89	0.79	0.60	0.39	0.91	0.82	0.62	0.40	0.95	0.85	0.64	0.41	0.96	0.86	0.65	0.42
	DT	20	19	15	11	21	19	16	11	21	19	16	11	21	19	16	11	20	19	15	11	19	18	14	10
1519	kW	2.81	2.87	2.96	3.05	3.02	3.09	3.18	3.28	3.21	3.28	3.38	3.49	3.37	3.44	3.56	3.67	3.51	3.59	3.70	3.83	3.63	3.71	3.83	3.96
	Amps	12.4	12.6	13.0	13.4	13.3	13.5	13.9	14.4	14.3	14.6	15.0	15.5	15.1	15.4	15.9	16.4	16.0	16.3	16.8	17.4	16.8	17.2	17.7	18.3
	Hi PR	224	241	255	266	251	271	286	298	286	308	325	339	326	350	370	386	366	394	416	434	405	436	460	480
	Lo PR	110	118	128	137	117	124	136	144	121	129	141	150	127	136	148	158	134	142	155	165	138	147	160	171
	MBh	39.1	40.3	43.6	46.8	38.2	39.3	42.6	45.7	37.3	38.4	41.6	44.6	36.4	37.5	40.6	43.5	34.6	35.6	38.5	41.3	32.0	33.0	35.7	38.3
	S/T	0.79	0.71	0.54	0.35	0.82	0.74	0.56	0.36	0.84	0.76	0.57	0.37	0.87	0.78	0.59	0.38	0.90	0.81	0.61	0.39	0.91	0.82	0.62	0.40
	DT	21	20	16	11	21	20	16	11	21	20	16	11	22	20	16	11	21	20	16	11	20	18	15	10
1350	kW	2.79	2.85	2.93	3.03	3.00	3.06	3.16	3.26	3.18	3.25	3.35	3.46	3.34	3.42	3.53	3.64	3.48	3.56	3.67	3.80	3.60	3.68	3.80	3.93
	Amps	12.3	12.5	12.9	13.3	13.2	13.4	13.8	14.3	14.1	14.4	14.9	15.4	15.0	15.3	15.8	16.3	15.8	16.2	16.7	17.2	16.7	17.1	17.6	18.2
	Hi PR	222	239	252	263	249	268	283	295	283	305	322	336	322	347	366	382	363	390	412	430	401	431	455	475
	Lo PR	109	116	127	135	116	123	134	143	120	128	139	149	126	134	147	156	132	141	154	164	137	145	159	169
	MBh	36.1	37.2	40.2	43.2	35.3	36.3	39.3	42.2	34.4	35.4	38.4	41.2	33.6	34.6	37.4	40.2	31.9	32.9	35.6	38.2	29.6	30.4	32.9	35.4
	S/T	0.77	0.69	0.52	0.33	0.79	0.71	0.54	0.35	0.81	0.73	0.55	0.35	0.84	0.75	0.57	0.37	0.87	0.78	0.59	0.38	0.88	0.79	0.60	0.38
	DT	22	20	16	11	22	20	16	11	22	20	16	11	22	20	17	11	22	20	16	11	20	19	15	11
1181	kW	2.72	2.78	2.87	2.95	2.93	2.99	3.08	3.18	3.11	3.17	3.27	3.38	3.26	3.33	3.44	3.55	3.40	3.47	3.58	3.70	3.51	3.59	3.71	3.83
	Amps	12.0	12.3	12.6	13.0	12.8	13.1	13.5	13.9	13.8	14.1	14.5	15.0	14.6	14.9	15.4	15.9	15.5	15.8	16.3	16.8	16.3	16.6	17.1	17.7
	Hi PR	215	232	245	255	241	260	274	286	275	296	312	325	313	337	355	371	352	379	400	417	389	418	442	461
	Lo PR	106	113	123	131	112	119	130	139	116	124	135	144	122	130	142	151	128	136	149	159	133	141	154	164

IDB: Entering Indoor Dry Bulb Temperature
 High & low pressures are measured at the liquid & suction access fittings.
 Shaded area reflects ACCA (ITVA) conditions
 kW = Total system power
 Amps = outdoor unit amps (comp.+ fans)

EXPANDED COOLING DATA — GPH1560M41* — LOW STAGE (CONT.)

IDB	AIRFLOW	OUTDOOR AMBIENT TEMPERATURE												ENTERING INDOOR WET BULB TEMPERATURE											
		65°F				75°F				85°F				95°F				105°F				115°F			
		59	63	67	71	59	63	67	71	59	63	67	71	59	63	67	71	59	63	67	71	59	63	67	71
80	MBh	41.0	41.9	44.8	47.9	40.1	40.9	43.7	46.7	39.1	40.0	42.7	45.6	38.1	39.0	41.6	44.5	36.2	37.0	39.6	42.3	33.6	34.3	36.6	39.2
	S/T	0.91	0.86	0.70	0.52	0.95	0.89	0.72	0.54	1.00	0.91	0.74	0.55	1.00	0.94	0.77	0.57	1.00	1.00	0.79	0.59	1.00	1.00	0.80	0.60
	ΔT	23	22	19	15	23	22	19	15	23	22	19	15	23	22	19	15	22	21	19	15	20	21	18	14
	kW	2.83	2.89	2.98	3.07	3.05	3.11	3.21	3.31	3.23	3.30	3.41	3.52	3.40	3.47	3.59	3.70	3.54	3.62	3.74	3.86	3.66	3.74	3.87	3.99
	Amps	12.5	12.7	13.1	13.5	13.4	13.6	14.0	14.5	14.4	14.7	15.1	15.6	15.2	15.6	16.0	16.6	16.1	16.5	17.0	17.5	17.0	17.3	17.9	18.5
	Hi PR	226	244	257	268	254	273	289	301	289	311	328	342	329	354	374	390	370	398	421	439	409	440	465	485
	Lo PR	112	119	130	138	118	125	137	146	123	130	142	152	129	137	149	159	135	143	157	167	140	148	162	173
	MBh	39.8	40.7	43.5	46.5	38.9	39.7	42.5	45.4	38.0	38.8	41.4	44.3	37.0	37.8	40.4	43.2	35.2	36.0	38.4	41.1	32.6	33.3	35.6	38.0
	S/T	0.87	0.82	0.67	0.50	0.90	0.85	0.69	0.52	0.93	0.87	0.71	0.53	0.96	0.90	0.73	0.55	0.99	0.93	0.76	0.57	1.00	0.94	0.76	0.57
	ΔT	24	23	20	16	24	23	20	16	24	23	20	16	24	23	20	16	24	23	20	16	22	21	19	15
kW	2.81	2.87	2.96	3.05	3.02	3.09	3.18	3.28	3.21	3.28	3.38	3.49	3.37	3.45	3.56	3.67	3.51	3.59	3.70	3.83	3.63	3.71	3.83	3.96	
Amps	12.4	12.6	13.0	13.4	13.3	13.5	13.9	14.4	14.3	14.6	15.0	15.5	15.1	15.4	15.9	16.4	16.0	16.3	16.8	17.4	16.8	17.2	17.7	18.3	
Hi PR	224	241	255	266	251	271	286	298	286	308	325	339	326	350	370	386	366	394	416	434	405	436	460	480	
Lo PR	110	118	128	137	117	124	136	144	121	129	141	150	127	136	148	158	134	142	155	165	138	147	160	171	
MBh	36.7	37.5	40.1	42.9	35.9	36.7	39.2	41.9	35.0	35.8	38.2	40.9	34.2	34.9	37.3	39.9	32.5	33.2	35.5	37.9	30.1	30.7	32.8	35.1	
S/T	0.84	0.79	0.64	0.48	0.87	0.82	0.67	0.50	0.89	0.84	0.68	0.51	0.92	0.86	0.70	0.53	0.96	0.90	0.73	0.55	0.97	0.91	0.74	0.55	
ΔT	24	23	20	16	24	23	20	16	24	23	20	16	25	24	20	16	24	23	20	16	23	22	19	15	
kW	2.75	2.80	2.89	2.98	2.95	3.01	3.11	3.20	3.13	3.20	3.30	3.40	3.29	3.36	3.47	3.58	3.43	3.50	3.61	3.73	3.54	3.62	3.74	3.86	
Amps	12.1	12.4	12.7	13.1	12.9	13.2	13.6	14.0	13.9	14.2	14.6	15.1	14.7	15.1	15.5	16.0	15.6	15.9	16.4	17.0	16.4	16.8	17.3	17.9	
Hi PR	217	234	247	258	244	262	277	289	277	298	315	329	316	340	359	374	355	382	404	421	393	423	446	465	
Lo PR	107	114	124	133	113	120	132	140	118	125	137	146	124	132	144	153	130	138	150	160	134	143	156	166	

1519	MBh	41.7	42.5	44.5	47.5	40.8	41.5	43.5	46.4	39.8	40.6	42.5	45.3	38.8	39.6	41.4	44.2	36.9	37.6	39.4	42.0	34.2	34.8	36.5	38.9
	S/T	0.96	0.92	0.83	0.68	0.99	0.96	0.86	0.70	1.00	0.98	0.89	0.72	1.00	1.00	0.92	0.74	1.00	1.00	0.95	0.77	1.00	1.00	0.96	0.78
	ΔT	24	24	22	19	24	24	23	20	24	24	23	20	23	24	23	20	22	23	23	20	21	21	21	18
	kW	2.85	2.91	3.00	3.10	3.07	3.13	3.23	3.34	3.26	3.33	3.44	3.55	3.43	3.50	3.61	3.73	3.57	3.65	3.77	3.89	3.69	3.77	3.90	4.03
	Amps	12.6	12.8	13.2	13.6	13.5	13.7	14.1	14.6	14.5	14.8	15.2	15.7	15.4	15.7	16.2	16.7	16.2	16.6	17.1	17.7	17.1	17.5	18.0	18.6
	Hi PR	229	246	260	271	256	276	291	304	292	314	331	346	332	358	378	394	374	402	425	443	413	444	469	489
	Lo PR	113	120	131	139	119	127	138	147	124	132	144	153	130	138	151	161	136	145	158	169	141	150	164	174
	MBh	40.5	41.3	43.2	46.1	39.6	40.3	42.2	45.1	38.6	39.4	41.2	44.0	37.7	38.4	40.2	42.9	35.8	36.5	38.2	40.8	33.2	33.8	35.4	37.8
	S/T	0.91	0.88	0.80	0.65	0.95	0.91	0.82	0.67	0.97	0.94	0.85	0.69	1.00	0.97	0.87	0.71	1.00	1.00	0.91	0.74	1.00	1.00	0.91	0.74
	ΔT	25	25	23	20	26	25	24	21	26	25	24	21	26	25	24	21	24	25	24	20	23	23	22	19
kW	2.83	2.89	2.98	3.07	3.05	3.11	3.21	3.31	3.23	3.30	3.41	3.52	3.40	3.47	3.59	3.70	3.54	3.62	3.74	3.86	3.66	3.74	3.87	3.99	
Amps	12.5	12.7	13.1	13.5	13.4	13.6	14.0	14.5	14.4	14.7	15.1	15.6	15.2	15.6	16.0	16.6	16.1	16.5	17.0	17.5	17.0	17.3	17.9	18.5	
Hi PR	226	244	257	268	254	273	289	301	289	311	328	342	329	354	374	390	370	398	421	439	409	440	465	485	
Lo PR	112	119	130	138	118	125	137	146	123	130	142	152	129	137	149	159	135	143	157	167	140	148	162	173	
MBh	37.4	38.1	39.9	42.6	36.5	37.2	39.0	41.6	35.6	36.3	38.1	40.6	34.8	35.5	37.1	39.6	33.0	33.7	35.3	37.6	30.6	31.2	32.7	34.9	
S/T	0.88	0.85	0.77	0.62	0.91	0.88	0.80	0.65	0.94	0.90	0.82	0.66	0.97	0.93	0.84	0.68	1.00	0.97	0.87	0.71	1.00	0.98	0.88	0.71	
ΔT	26	25	24	21	26	26	24	21	26	26	24	21	26	26	24	21	26	25	24	21	24	24	22	19	
kW	2.77	2.82	2.91	3.00	2.97	3.04	3.13	3.23	3.16	3.22	3.33	3.43	3.32	3.39	3.50	3.61	3.45	3.53	3.64	3.76	3.57	3.65	3.77	3.89	
Amps	12.2	12.4	12.8	13.2	13.0	13.3	13.7	14.1	14.0	14.3	14.7	15.2	14.9	15.2	15.6	16.2	15.7	16.1	16.5	17.1	16.5	16.9	17.4	18.0	
Hi PR	220	236	249	260	246	265	280	292	280	301	318	332	319	343	363	378	359	386	408	425	397	427	451	470	
Lo PR	108	115	126	134	114	122	133	141	119	126	138	147	125	133	145	154	131	139	152	162	135	144	157	167	

IDB: Entering Indoor Dry Bulb Temperature
 High & low pressures are measured at the liquid & suction access fittings.
 Shaded area reflects AHRI (TVA) conditions
 kW = Total system power
 Amps = outdoor unit amps (comp.+ fans)

EXPANDED COOLING DATA — GPH1560M41* — HIGH STAGE

IDB	AIRFLOW	OUTDOOR AMBIENT TEMPERATURE												ENTERING INDOOR WET BULB TEMPERATURE											
		65°F				75°F				85°F				95°F				105°F				115°F			
		59	63	67	71	59	63	67	71	59	63	67	71	59	63	67	71	59	63	67	71	59	63	67	71
70	MBh	54.4	56.4	61.8	-	53.2	55.1	60.4	-	51.9	53.8	58.9	-	50.6	52.5	57.5	-	48.1	49.9	54.6	-	44.6	46.2	50.6	-
	S/T	0.71	0.60	0.41	-	0.74	0.62	0.43	-	0.76	0.63	0.44	-	0.78	0.65	0.45	-	0.81	0.68	0.47	-	0.82	0.68	0.47	-
	DT	18	15	12	-	18	15	12	-	18	15	12	-	18	16	12	-	18	15	12	-	17	14	11	-
	KW	4.22	4.31	4.44	-	4.54	4.63	4.78	-	4.82	4.92	5.08	-	5.06	5.17	5.34	-	5.27	5.39	5.56	-	5.45	5.57	5.75	-
	Amps	18.4	18.8	19.3	-	19.7	20.1	20.7	-	21.1	21.6	22.2	-	22.4	22.9	23.6	-	23.7	24.2	25.0	-	25.0	25.5	26.3	-
	Hi PR	240	258	273	-	269	290	306	-	306	330	348	-	349	375	396	-	392	422	446	-	434	467	493	-
	Lo PR	106	112	123	-	112	119	130	-	116	124	135	-	122	130	142	-	128	136	148	-	132	141	154	-
	MBh	52.8	54.8	60.0	-	51.6	53.5	58.6	-	50.4	52.2	57.2	-	49.2	50.9	55.8	-	46.7	48.4	53.0	-	43.3	44.8	49.1	-
	S/T	0.68	0.57	0.39	-	0.70	0.59	0.41	-	0.72	0.60	0.42	-	0.75	0.62	0.43	-	0.77	0.65	0.45	-	0.78	0.65	0.45	-
	DT	18	16	12	-	19	16	12	-	19	16	12	-	19	16	12	-	18	16	12	-	17	15	11	-
	KW	4.19	4.28	4.41	-	4.50	4.60	4.74	-	4.78	4.88	5.03	-	5.02	5.13	5.29	-	5.23	5.34	5.52	-	5.41	5.53	5.71	-
	Amps	18.2	18.6	19.1	-	19.5	19.9	20.5	-	21.0	21.4	22.1	-	22.2	22.7	23.4	-	23.5	24.0	24.8	-	24.8	25.3	26.1	-
Hi PR	238	256	270	-	267	287	303	-	303	326	345	-	345	372	392	-	388	418	441	-	429	462	488	-	
Lo PR	105	111	122	-	111	118	128	-	115	122	134	-	121	128	140	-	127	135	147	-	131	139	152	-	
MBh	48.8	50.5	55.4	-	47.6	49.4	54.1	-	46.5	48.2	52.8	-	45.4	47.0	51.5	-	43.1	44.7	48.9	-	39.9	41.4	45.3	-	
S/T	0.66	0.55	0.38	-	0.68	0.57	0.39	-	0.70	0.58	0.40	-	0.72	0.60	0.42	-	0.75	0.62	0.43	-	0.75	0.63	0.44	-	
DT	19	16	12	-	19	16	12	-	19	16	12	-	19	16	13	-	19	16	12	-	18	15	12	-	
KW	4.09	4.18	4.30	-	4.40	4.49	4.63	-	4.66	4.76	4.91	-	4.90	5.01	5.16	-	5.10	5.21	5.38	-	5.27	5.39	5.56	-	
Amps	17.8	18.2	18.7	-	19.0	19.4	20.0	-	20.5	20.9	21.5	-	21.7	22.2	22.8	-	22.9	23.4	24.1	-	24.2	24.7	25.4	-	
Hi PR	230	248	262	-	259	278	294	-	294	316	334	-	335	360	381	-	377	406	428	-	416	448	473	-	
Lo PR	102	108	118	-	107	114	125	-	112	119	130	-	117	125	136	-	123	131	143	-	127	135	147	-	

2025	MBh	55.3	57.0	61.7	66.2	54.1	55.7	60.2	64.7	52.8	54.3	58.8	63.1	51.5	53.0	57.4	61.6	48.9	50.4	54.5	58.5	45.3	46.6	50.5	54.2
	S/T	0.81	0.73	0.55	0.35	0.84	0.75	0.57	0.37	0.86	0.77	0.58	0.38	0.89	0.80	0.60	0.39	0.92	0.83	0.62	0.40	0.93	0.83	0.63	0.41
	DT	20	19	15	11	21	19	16	11	21	19	16	11	21	19	16	11	20	19	15	11	19	18	14	10
	KW	4.26	4.34	4.48	4.62	4.57	4.67	4.82	4.97	4.86	4.96	5.12	5.28	5.10	5.21	5.38	5.56	5.32	5.43	5.61	5.79	5.50	5.62	5.80	6.00
	Amps	18.5	18.9	19.4	20.1	19.8	20.2	20.8	21.5	21.3	21.8	22.4	23.2	22.6	23.1	23.8	24.6	23.9	24.4	25.2	26.0	25.2	25.8	26.5	27.5
	Hi PR	242	261	275	287	272	293	309	322	309	333	352	367	352	379	400	418	396	427	450	470	438	471	498	519
	Lo PR	107	114	124	132	113	120	131	140	117	125	136	145	123	131	143	152	129	137	150	160	134	142	155	165
	MBh	53.7	55.3	59.9	64.3	52.5	54.0	58.5	62.8	51.2	52.8	57.1	61.3	50.0	51.5	55.7	59.8	47.5	48.9	52.9	56.8	44.0	45.3	49.0	52.6
	S/T	0.77	0.69	0.52	0.34	0.80	0.72	0.54	0.35	0.82	0.73	0.56	0.36	0.85	0.76	0.57	0.37	0.88	0.79	0.60	0.38	0.89	0.79	0.60	0.39
	DT	21	20	16	11	21	20	16	11	21	20	16	11	22	20	16	11	21	20	16	11	20	18	15	10
	KW	4.22	4.31	4.44	4.58	4.54	4.63	4.78	4.93	4.82	4.92	5.08	5.24	5.06	5.17	5.34	5.51	5.27	5.39	5.56	5.75	5.45	5.57	5.75	5.95
	Amps	18.4	18.8	19.3	19.9	19.7	20.1	20.7	21.3	21.1	21.6	22.2	23.0	22.4	22.9	23.6	24.4	23.7	24.2	25.0	25.8	25.0	25.5	26.3	27.2
Hi PR	240	258	273	284	269	290	306	319	306	330	348	363	349	375	396	413	392	422	446	465	434	467	493	514	
Lo PR	106	113	123	131	112	119	130	138	116	124	135	144	122	130	142	151	128	136	148	158	132	141	154	164	
MBh	49.6	51.1	55.3	59.3	48.4	49.9	54.0	57.9	47.3	48.7	52.7	56.6	46.1	47.5	51.4	55.2	43.8	45.1	48.8	52.4	40.6	41.8	45.2	48.6	
S/T	0.75	0.67	0.50	0.32	0.77	0.69	0.52	0.34	0.79	0.71	0.54	0.35	0.82	0.73	0.55	0.36	0.85	0.76	0.57	0.37	0.86	0.77	0.58	0.37	
DT	22	20	16	11	22	20	16	11	22	20	16	11	22	20	17	11	22	20	16	11	20	19	15	11	
KW	4.13	4.21	4.34	4.47	4.43	4.52	4.66	4.81	4.70	4.80	4.95	5.11	4.94	5.05	5.21	5.38	5.14	5.25	5.42	5.60	5.32	5.43	5.61	5.80	
Amps	18.0	18.3	18.8	19.4	19.2	19.6	20.2	20.8	20.6	21.1	21.7	22.4	21.9	22.4	23.0	23.8	23.1	23.6	24.3	25.2	24.4	24.9	25.6	26.5	
Hi PR	233	251	265	276	261	281	297	310	297	320	338	352	338	364	385	401	381	410	433	451	421	453	478	498	
Lo PR	103	109	119	127	108	115	126	134	113	120	131	139	118	126	137	146	124	132	144	153	128	136	149	159	

IDB: Entering Indoor Dry Bulb Temperature
High & low pressures are measured at the liquid & suction access fittings.

Shaded area reflects ACCA (ITVA) conditions

kW = Total system power
Amps = outdoor unit amps (comp.+ fans)

EXPANDED COOLING DATA — GPH1560M41* — HIGH STAGE (CONT.)

IDB	AIRFLOW	OUTDOOR AMBIENT TEMPERATURE												ENTERING INDOOR WET BULB TEMPERATURE													
		65°F				75°F				85°F				95°F				105°F				115°F					
		59	63	67	71	59	63	67	71	59	63	67	71	59	63	67	71	59	63	67	71	59	63	67	71		
70	2025	MBh	56.3	57.6	61.5	65.7	55.0	56.2	60.1	64.2	53.7	54.9	58.6	62.7	52.4	53.5	57.2	61.2	49.8	50.9	54.3	58.1	46.1	47.1	50.3	53.8	
		S/T	0.89	0.83	0.68	0.51	0.92	0.86	0.70	0.53	0.94	0.89	0.72	0.54	1.00	0.91	0.74	0.56	1.00	0.95	0.77	0.58	1.00	0.96	0.78	0.58	
		ΔT	23	22	19	15	23	22	19	15	24	22	19	15	24	22	19	15	23	22	19	15	21	20	18	14	
	1800	kW	4.29	4.38	4.51	4.65	4.61	4.71	4.86	5.01	4.90	5.00	5.16	5.33	5.15	5.26	5.43	5.61	5.36	5.48	5.65	5.84	5.54	5.67	5.85	6.05	
		Amps	18.7	19.1	19.6	20.2	20.0	20.4	21.0	21.7	21.5	22.0	22.6	23.4	22.8	23.3	24.0	24.8	24.1	24.6	25.4	26.3	25.4	26.0	26.8	27.7	
		Hi PR	245	263	278	290	275	296	312	326	312	336	355	370	356	383	404	422	400	431	455	475	442	476	503	524	
	1575	Lo PR	108	115	125	133	114	121	132	141	118	126	138	147	124	132	145	154	130	139	151	161	135	144	157	167	
		MBh	54.7	55.9	59.7	63.8	53.4	54.6	58.3	62.3	52.1	53.3	56.9	60.9	50.9	52.0	55.5	59.4	48.3	49.4	52.8	56.4	44.8	45.7	48.9	52.2	
		S/T	0.85	0.80	0.65	0.48	0.88	0.82	0.67	0.50	0.90	0.85	0.69	0.51	0.93	0.87	0.71	0.53	0.97	0.91	0.74	0.55	0.97	0.91	0.74	0.56	
	75	2025	ΔT	24	23	20	16	24	23	20	16	24	23	20	16	24	23	20	16	24	23	20	16	22	21	19	15
			kW	4.26	4.34	4.48	4.62	4.57	4.67	4.82	4.97	4.86	4.96	5.12	5.28	5.10	5.22	5.38	5.56	5.32	5.43	5.61	5.79	5.50	5.62	5.80	6.00
			Amps	18.5	18.9	19.4	20.1	19.8	20.2	20.8	21.5	21.3	21.8	22.4	23.2	22.6	23.1	23.8	24.6	23.9	24.4	25.2	26.0	25.2	25.8	26.5	27.5
1800		Hi PR	242	261	275	287	272	293	309	322	309	333	352	367	352	379	400	418	396	427	450	470	438	471	498	519	
		Lo PR	107	114	124	132	113	120	131	140	117	125	136	145	123	131	143	152	129	137	150	160	134	142	155	165	
		MBh	50.5	51.6	55.1	58.9	49.3	50.4	53.8	57.5	48.1	49.2	52.5	56.2	47.0	48.0	51.3	54.8	44.6	45.6	48.7	52.1	41.3	42.2	45.1	48.2	
1575		S/T	0.82	0.77	0.62	0.47	0.85	0.79	0.65	0.48	0.87	0.81	0.66	0.50	0.90	0.84	0.68	0.51	0.93	0.87	0.71	0.53	0.94	0.88	0.72	0.54	
		ΔT	24	23	20	16	24	23	20	16	24	23	20	16	25	24	20	16	24	23	20	16	23	22	19	15	
		kW	4.16	4.24	4.37	4.51	4.47	4.56	4.70	4.85	4.74	4.84	4.99	5.15	4.98	5.09	5.25	5.42	5.19	5.30	5.47	5.65	5.36	5.48	5.66	5.85	
75		Amps	18.1	18.5	19.0	19.6	19.4	19.8	20.3	21.0	20.8	21.2	21.9	22.6	22.1	22.5	23.2	24.0	23.3	23.8	24.5	25.4	24.6	25.1	25.9	26.8	
		Hi PR	235	253	267	279	264	284	300	313	300	323	341	356	342	368	388	405	385	414	437	456	425	457	483	504	
		Lo PR	104	110	120	128	109	116	127	135	114	121	132	141	120	127	139	148	125	133	145	155	130	138	150	160	
75	2025	MBh	57.3	58.4	61.2	65.3	56.0	57.1	59.8	63.8	54.6	55.7	58.3	62.2	53.3	54.3	56.9	60.7	50.7	51.6	54.1	57.7	46.9	47.8	50.1	53.4	
		S/T	0.93	0.90	0.81	0.66	0.97	0.93	0.84	0.68	0.99	0.96	0.86	0.70	1.00	0.99	0.89	0.72	1.00	1.00	0.92	0.75	1.00	1.00	0.93	0.76	
		ΔT	24	24	23	20	25	24	23	20	25	24	23	20	24	24	23	20	23	23	23	20	21	22	21	18	
	1800	kW	4.32	4.41	4.55	4.69	4.65	4.75	4.90	5.05	4.93	5.04	5.20	5.37	5.19	5.30	5.47	5.65	5.40	5.52	5.70	5.89	5.59	5.71	5.90	6.10	
		Amps	18.8	19.2	19.8	20.4	20.1	20.6	21.2	21.9	21.7	22.1	22.8	23.6	23.0	23.5	24.2	25.0	24.3	24.9	25.6	26.5	25.6	26.2	27.0	27.9	
		Hi PR	247	266	281	293	277	299	315	329	316	340	359	374	359	387	408	426	404	435	460	479	447	481	508	530	
	1575	Lo PR	109	116	127	135	115	122	134	142	120	127	139	148	126	134	146	155	132	140	153	163	136	145	158	169	
		MBh	55.6	56.7	59.4	63.4	54.4	55.4	58.0	61.9	53.1	54.1	56.6	60.4	51.8	52.8	55.3	59.0	49.2	50.1	52.5	56.0	45.6	46.4	48.6	51.9	
		S/T	0.89	0.86	0.77	0.63	0.92	0.89	0.80	0.65	0.94	0.91	0.82	0.67	0.98	0.94	0.85	0.69	1.00	0.98	0.88	0.72	1.00	0.98	0.89	0.72	
	75	ΔT	25	25	23	20	26	25	24	21	26	25	24	21	26	25	24	21	25	25	24	20	23	23	22	19	
		kW	4.29	4.38	4.51	4.65	4.61	4.71	4.86	5.01	4.90	5.00	5.16	5.33	5.15	5.26	5.43	5.61	5.36	5.48	5.65	5.84	5.54	5.67	5.85	6.05	
		Amps	18.7	19.1	19.6	20.2	20.0	20.4	21.0	21.7	21.5	22.0	22.6	23.4	22.8	23.3	24.0	24.8	24.1	24.6	25.4	26.3	25.4	26.0	26.8	27.7	
1575	Hi PR	245	263	278	290	275	296	312	326	312	336	355	370	356	383	404	422	400	431	455	475	442	476	503	524		
	Lo PR	108	115	125	133	114	121	132	141	118	126	138	147	124	132	145	154	130	139	151	161	135	144	157	167		
	MBh	51.4	52.4	54.8	58.5	50.2	51.1	53.6	57.1	49.0	49.9	52.3	55.8	47.8	48.7	51.0	54.4	45.4	46.3	48.5	51.7	42.0	42.9	44.9	47.9		
75	S/T	0.86	0.83	0.75	0.61	0.89	0.86	0.77	0.63	0.91	0.88	0.79	0.64	0.94	0.91	0.82	0.66	0.98	0.94	0.85	0.69	0.98	0.95	0.86	0.70		
	ΔT	26	25	24	21	26	26	24	21	26	26	24	21	26	26	24	21	26	25	24	21	24	24	22	19		
	kW	4.19	4.28	4.41	4.54	4.50	4.60	4.74	4.89	4.78	4.88	5.03	5.20	5.02	5.13	5.29	5.47	5.23	5.34	5.51	5.70	5.41	5.52	5.70	5.89		
75	Amps	18.2	18.6	19.1	19.8	19.5	19.9	20.5	21.2	21.0	21.4	22.0	22.8	22.2	22.7	23.4	24.2	23.5	24.0	24.8	25.6	24.8	25.3	26.1	27.0		
	Hi PR	237	256	270	281	266	287	303	316	303	326	344	359	345	371	392	409	388	418	441	460	429	462	488	509		
	Lo PR	105	111	122	129	111	118	128	137	115	122	133	142	121	128	140	149	127	135	147	156	131	139	152	162		

IDB: Entering Indoor Dry Bulb Temperature
 High & low pressures are measured at the liquid & suction access fittings.
 Shaded area reflects AHRH (TVA) conditions
 kW = Total system power
 Amps = outdoor unit amps (comp.+ fans)

AIRFLOW DATA

MODEL	MOTOR TAP SPEED	VOLTS		E.S.P (IN. OF H ₂ O)							
				0.1	0.2	0.3	0.4	0.5	0.6	0.7	0.8
GPH15 24M41A	T1 (G)	230	CFM	882	808	727	649	545	---	---	---
			Watts	82	86	92	102	108	---	---	---
	T2 / T3 (W2)	230	CFM	933	873	810	733	637	584	---	---
			Watts	93	103	109	120	126	135	---	---
	T4 / T5 (Y)	230	CFM	1058	1012	945	896	816	723	672	---
			Watts	124	136	142	153	168	172	179	---
GPH15 30M41A	T1 (G)	230	CFM	893	824	752	665	575	---	---	---
			Watts	87	95	101	111	115	---	---	---
	T2 / T3 (W2)	230	CFM	1132	1070	1011	959	889	827	733	669
			Watts	153	162	168	179	184	195	206	208
	T4 / T5 (Y)	230	CFM	1287	1236	1165	1123	1066	1012	958	857
			Watts	211	217	228	239	244	255	265	272
GPH15 36M41A	T1 (G)	230	CFM	852	764	711	592	545	-	-	-
			Watts	80	82	86	95	99	-	-	-
	T2 / T3 (W2)	230	CFM	1232	1190	1131	1082	1023	966	889	819
			Watts	202	214	221	229	235	246	258	264
	T4 / T5 (Y)	230	CFM	1267	1213	1162	1120	1058	1009	932	841
			Watts	218	226	236	245	247	260	272	275
GPH15 42M41A	T1 (G)	230	CFM	893	830	741	619	557	---	---	---
			Watts	89	99	104	117	131	---	---	---
	T2 / T3 (W2)	230	CFM	1393	1339	1297	1230	1180	1116	1056	901
			Watts	271	280	292	300	310	320	324	329
	T4 / T5 (Y)	230	CFM	1511	1464	1422	1355	1313	1184	1064	983
			Watts	345	354	364	381	390	392	375	360

G = Fan only W2 = Heat mode Y = Cooling mode

Notes

- Data shown is dry coil. Wet coil pressure drop is approximately 0.1" H₂O, for two-row indoor coil; 0.2" H₂O, for three-row indoor coil; and 0.3" H₂O, for four-row indoor coil.
- Data shown does not include filter pressure drop, approx. 0.08" H₂O.
- ALL MODELS SHOULD RUN NO LESS THAN 350 CFM/TON. USE HIGHER SPEED TAP OR NEXT SIZE LARGER BLOWER ASM. See Repair Parts list.
- Reduce airflow by 2% for 208-volt operation.

AIRFLOW DATA (CONT.)

MODEL	MOTOR TAP SPEED	VOLTS		E.S.P (IN. OF H ₂ O)							
				0.1	0.2	0.3	0.4	0.5	0.6	0.7	0.8
GPH15 43M41*	T1 (G)	230	CFM	1199	1138	1085	1017	957	889	820	755
			Watts	162	173	185	193	211	219	232	245
	T2 / T3 (W2)	230	CFM	1359	1322	1262	1214	1165	1119	1080	1039
			Watts	200	214	218	233	243	254	267	283
	T4 / T5 (HS)	230	CFM	1598	1559	1525	1483	1441	1398	1353	1314
			Watts	332	343	360	365	384	385	404	414
GPH15 48M41A	T1 (G)	230	CFM	1199	1138	1085	1017	957	889	820	755
			Watts	162	173	185	193	211	219	232	245
	T2 / T3 (W2)	230	CFM	1799	1745	1698	1658	1610	1560	1522	1450
			Watts	480	493	508	521	531	545	550	547
	T4 / T5 (Y)	230	CFM	1921	1865	1818	1780	1719	1667	1579	1483
			Watts	582	585	602	625	627	621	595	569
GPH15 49M41*	T1 (G)	230	CFM	1199	1138	1085	1017	957	889	820	755
			Watts	162	173	185	193	211	219	232	245
	T2 (Y)	230	CFM	1418	1383	1349	1312	1275	1228	1178	1141
			Watts	242	258	273	282	299	308	320	338
	T3 (W2)	230	CFM	1799	1745	1698	1658	1610	1560	1522	1450
			Watts	480	493	508	521	531	545	550	547
	T4 (YHS)	230	CFM	1799	1745	1698	1658	1610	1560	1522	1450
			Watts	480	493	508	521	531	545	550	547
	T5 (W2HS)	230	CFM	1921	1865	1818	1780	1719	1667	1579	1483
			Watts	582	585	602	625	627	621	595	569
GPH15 60M41A	T1 (G)	230	CFM	1390	1325	1282	1223	1180	1134	1066	1011
			Watts	231	240	253	262	277	292	300	316
	T2 / T3 (W2)	230	CFM	1900	1843	1801	1762	1723	1672	1577	1482
			Watts	543	559	569	583	600	603	577	554
	T4 / T5 Y	230	CFM	2094	2039	1981	1907	1819	1731	1628	1497
			Watts	724	727	720	701	671	653	611	569

G = Fan only W2 = Heat mode Y = Cooling mode

Notes

- Data shown is dry coil. Wet coil pressure drop is approximately 0.1" H₂O, for two-row indoor coil; 0.2" H₂O, for three-row indoor coil; and 0.3" H₂O, for four-row indoor coil.
- Data shown does not include filter pressure drop, approx. 0.08" H₂O.
- ALL MODELS SHOULD RUN NO LESS THAN 350 CFM/TON. USE HIGHER SPEED TAP OR NEXT SIZE LARGER BLOWER ASM. See Repair Parts list.
- Reduce airflow by 2% for 208-volt operation.

EXPANDED HEATING DATA

GPH1524M41*

	OUTDOOR AMBIENT TEMPERATURE																	
	65	60	55	50	47	45	40	35	30	25	20	17	15	10	5	0	-5	-10
MBh	29.4	27.8	26.2	24.5	23.4	22.7	21.1	19.4	15.6	14.4	13.2	12.5	12.0	10.8	9.6	8.4	7.1	5.8
ΔT	31.7	30.0	28.2	26.4	25.2	24.4	22.7	20.9	16.8	15.5	14.3	13.5	13.0	11.6	10.3	9.0	7.7	6.3
kW	2.08	2.04	2.00	1.96	1.94	1.92	1.88	1.84	1.81	1.77	1.73	1.71	1.69	1.65	1.61	1.57	1.53	1.49
Amps	10.8	10.2	9.6	9.2	8.9	8.8	8.4	8.0	7.8	7.5	7.2	7.1	7.0	6.8	6.4	6.2	5.8	5.4
COP	4.14	4.00	3.84	3.66	3.54	3.46	3.28	3.09	2.52	2.38	2.24	2.15	2.09	1.92	1.74	1.56	1.36	1.15
EER	14.2	13.7	13.1	12.5	12.1	11.8	11.2	10.6	8.6	8.1	7.7	7.3	7.1	6.6	6.0	5.3	4.7	3.9
HI PR	388	372	358	342	334	328	315	302	290	277	266	259	255	245	235	226	218	210
LO PR	145	134	126	115	109	105	96	86	77	69	61	57	55	46	40	34	29	23

GPH1530M41**

	OUTDOOR AMBIENT TEMPERATURE																	
	65	60	55	50	47	45	40	35	30	25	20	17	15	10	5	0	-5	-10
MBh	34.4	32.6	30.7	28.7	27.4	26.6	24.7	22.7	18.8	17.4	16.0	15.1	14.5	13.0	11.6	10.1	8.6	7.1
ΔT	31.9	30.2	28.4	26.6	25.4	24.6	22.8	21.1	17.4	16.1	14.8	14.0	13.5	12.1	10.7	9.3	8.0	6.5
kW	2.31	2.27	2.22	2.18	2.15	2.13	2.09	2.04	2.08	2.03	1.98	1.95	1.93	1.89	1.84	1.79	1.74	1.69
Amps	11.4	10.7	10.0	9.5	9.2	9.0	8.5	8.2	7.8	7.5	7.2	7.1	7.0	6.7	6.3	6.0	5.6	5.1
COP	4.36	4.21	4.04	3.86	3.73	3.65	3.46	3.26	2.65	2.51	2.36	2.26	2.20	2.03	1.84	1.65	1.45	1.22
EER	14.9	14.4	13.8	13.2	12.8	12.5	11.8	11.2	9.1	8.6	8.1	7.7	7.5	6.9	6.3	5.6	4.9	4.2
HI PR	383	368	353	338	330	324	311	299	286	273	262	256	251	242	233	223	215	208
LO PR	138	128	120	110	104	100	92	82	74	66	58	54	52	44	38	32	28	22

GPH1536M41*

	OUTDOOR AMBIENT TEMPERATURE																	
	65	60	55	50	47	45	40	35	30	25	20	17	15	10	5	0	-5	-10
MBh	44.6	42.2	39.8	37.2	35.5	34.4	32.0	29.5	23.2	21.4	19.7	18.6	17.9	16.1	14.3	12.4	10.6	8.7
ΔT	34.4	32.6	30.7	28.7	27.4	26.5	24.7	22.7	17.9	16.5	15.2	14.4	13.8	12.4	11.0	9.6	8.2	6.7
kW	3.24	3.18	3.11	3.05	3.01	2.98	2.92	2.85	2.43	2.37	2.32	2.29	2.26	2.21	2.15	2.10	2.04	1.99
Amps	17.4	16.2	15.3	14.5	14.1	13.9	13.2	12.6	12.2	11.7	11.3	11.1	10.9	10.5	9.9	9.5	8.9	8.3
COP	4.03	3.89	3.74	3.57	3.45	3.38	3.21	3.02	2.80	2.64	2.49	2.38	2.32	2.13	1.94	1.73	1.52	1.28
EER	13.8	13.3	12.8	12.2	11.8	11.5	11.0	10.3	9.6	9.0	8.5	8.1	7.9	7.3	6.6	5.9	5.2	4.4
HI PR	454	435	418	400	390	383	368	353	338	323	310	303	297	286	275	264	254	245
LO PR	137	127	119	109	103	99	91	81	73	65	57	53	52	44	38	32	28	22

GPH1542M41*

LOW STAGE

	OUTDOOR AMBIENT TEMPERATURE																	
	65	60	55	50	47	45	40	35	30	25	20	17	15	10	5	0	-5	-10
MBh	33.3	31.5	29.7	27.7	26.5	25.7	23.9	22.0	16.2	15.0	13.8	13.0	12.5	11.2	10.0	8.7	7.4	6.1
ΔT	36.3	34.4	32.3	30.2	28.9	28.0	26.0	24.0	17.6	16.3	15.0	14.2	13.6	12.2	10.8	9.5	8.1	6.6
kW	2.48	2.43	2.38	2.33	2.30	2.28	2.23	2.18	2.19	2.13	2.08	2.05	2.03	1.97	1.92	1.87	1.82	1.76
Amps	12.5	11.6	10.9	10.3	9.9	9.7	9.2	8.8	8.4	8.1	7.7	7.5	7.4	7.1	6.6	6.3	5.8	5.3
COP	3.92	3.79	3.65	3.49	3.37	3.30	3.13	2.96	2.17	2.05	1.94	1.86	1.81	1.67	1.52	1.36	1.19	1.01
EER	13.4	13.0	12.5	11.9	11.5	11.3	10.7	10.1	7.4	7.0	6.6	6.3	6.2	5.7	5.2	4.6	4.1	3.4
HI PR	395	379	364	348	340	334	321	308	295	282	270	264	259	249	240	230	222	214
LO PR	143	133	125	114	108	104	96	85	77	69	60	56	54	46	39	33	29	23

Notes:

Above information is for nominal CFM and 70-degree indoor dry bulb. Instantaneous capacity listed.

High pressure is measured at the liquid line access fitting.

Low pressure is measured at the compressor suction access fitting.

Amps: Unit amps (comp.+ evaporator motor + condenser fan motor)

kW = Total system power

EXPANDED HEATING DATA (CONT.)

GPH1542M41*

HIGH STAGE

	OUTDOOR AMBIENT TEMPERATURE																	
	65	60	55	50	47	45	40	35	30	25	20	17	15	10	5	0	-5	-10
MBh	50.3	47.6	44.8	41.9	40.0	38.8	36.0	33.2	24.9	23.0	21.2	20.0	19.3	17.3	15.3	13.4	11.4	9.3
ΔT	37.2	35.3	33.2	31.0	29.6	28.7	26.7	24.6	18.5	17.0	15.7	14.8	14.3	12.8	11.3	9.9	8.4	6.9
kW	3.42	3.35	3.28	3.21	3.17	3.14	3.07	3.00	2.89	2.82	2.75	2.71	2.68	2.61	2.55	2.48	2.41	2.35
Amps	16.8	15.6	14.7	13.9	13.4	13.2	12.5	11.9	11.4	10.9	10.5	10.2	10.1	9.7	9.1	8.6	8.0	7.3
COP	4.31	4.16	4.00	3.82	3.70	3.61	3.43	3.24	2.53	2.39	2.25	2.16	2.10	1.93	1.76	1.58	1.38	1.16
EER	14.7	14.2	13.7	13.1	12.6	12.3	11.7	11.1	8.6	8.2	7.7	7.4	7.2	6.6	6.0	5.4	4.7	4.0
HI PR	402	385	371	354	346	339	326	313	300	286	275	268	264	254	244	234	226	218
LO PR	135	126	118	108	102	98	90	80	73	65	57	53	51	43	37	31	27	22

GPH1543M41**

	OUTDOOR AMBIENT TEMPERATURE																	
	65	60	55	50	47	45	40	35	30	25	20	17	15	10	5	0	-5	-10
MBh	50.2	47.5	44.7	41.8	39.9	38.7	35.9	33.1	23.2	21.4	19.7	18.6	17.9	16.1	14.3	12.4	10.6	8.7
ΔT	38.7	36.6	34.5	32.2	30.8	29.8	27.7	25.6	17.9	16.5	15.2	14.4	13.8	12.4	11.0	9.6	8.2	6.7
kW	3.45	3.38	3.31	3.24	3.20	3.17	3.10	3.03	2.43	2.37	2.32	2.29	2.26	2.21	2.15	2.10	2.04	1.99
Amps	18.5	17.3	16.3	15.5	15.0	14.8	14.0	13.4	12.9	12.5	12.0	11.7	11.6	11.1	10.5	10.0	9.4	8.7
COP	4.25	4.11	3.95	3.77	3.65	3.57	3.39	3.20	2.80	2.64	2.49	2.38	2.32	2.13	1.94	1.73	1.52	1.28
EER	14.5	14.0	13.5	12.9	12.5	12.2	11.6	10.9	9.6	9.0	8.5	8.1	7.9	7.3	6.6	5.9	5.2	4.4
HI PR	413	395	380	364	355	348	335	321	308	294	282	275	271	260	250	240	231	223
LO PR	143	133	125	114	108	104	96	85	77	69	60	56	54	46	39	33	29	23

GPH1548M41**

LOW STAGE

	OUTDOOR AMBIENT TEMPERATURE																	
	65	60	55	50	47	45	40	35	30	25	20	17	15	10	5	0	-5	-10
MBh	40.0	37.8	35.6	33.3	31.8	30.8	28.6	26.4	21.8	20.1	18.5	17.5	16.9	15.1	13.4	11.7	10.0	8.2
ΔT	30.8	29.2	27.5	25.7	24.5	23.8	22.1	20.4	16.8	15.5	14.3	13.5	13.0	11.7	10.3	9.0	7.7	6.3
kW	3.04	2.98	2.92	2.86	2.83	2.80	2.74	2.69	2.81	2.74	2.68	2.64	2.62	2.55	2.49	2.43	2.36	2.30
Amps	11.5	10.8	10.2	9.7	9.4	9.3	8.8	8.5	8.2	7.9	7.6	7.5	7.4	7.1	6.8	6.5	6.1	5.7
COP	3.85	3.72	3.57	3.41	3.29	3.22	3.05	2.88	2.27	2.15	2.02	1.94	1.88	1.73	1.58	1.41	1.24	1.04
EER	13.1	12.7	12.2	11.6	11.2	11.0	10.4	9.8	7.8	7.3	6.9	6.6	6.4	5.9	5.4	4.8	4.2	3.6
HI PR	395	379	364	348	340	334	321	308	295	282	270	264	259	249	240	230	222	214
LO PR	139	129	121	111	105	101	93	83	75	67	59	54	52	44	38	32	28	22

GPH1548M41*

HIGH STAGE

	OUTDOOR AMBIENT TEMPERATURE																	
	65	60	55	50	47	45	40	35	30	25	20	17	15	10	5	0	-5	-10
MBh	57.4	54.3	51.1	47.8	45.7	44.2	41.1	37.9	30.7	28.3	26.1	24.6	23.7	21.3	18.8	16.4	14.0	11.5
ΔT	31.3	29.6	27.8	26.0	24.9	24.1	22.4	20.6	16.7	15.4	14.2	13.4	12.9	11.6	10.3	9.0	7.6	6.3
kW	4.20	4.12	4.04	3.96	3.92	3.88	3.81	3.73	3.66	3.58	3.50	3.45	3.42	3.34	3.26	3.19	3.11	3.03
Amps	20.6	19.2	18.2	17.2	16.7	16.4	15.6	15.0	14.4	13.9	13.3	13.1	12.9	12.4	11.7	11.2	10.5	9.7
COP	4.00	3.86	3.70	3.53	3.41	3.34	3.16	2.98	2.45	2.32	2.18	2.09	2.03	1.86	1.69	1.51	1.32	1.11
EER	13.7	13.2	12.7	12.1	11.7	11.4	10.8	10.2	8.4	7.9	7.4	7.1	6.9	6.4	5.8	5.2	4.5	3.8
HI PR	411	394	379	363	354	347	334	320	307	293	282	275	270	260	250	239	231	223
LO PR	131	122	114	105	99	95	88	78	70	63	55	51	50	42	36	30	27	21

Notes:

Above information is for nominal CFM and 70-degree indoor dry bulb. Instantaneous capacity listed.

High pressure is measured at the liquid line access fitting.

Amps: Unit amps (comp.+ evaporator motor + condenser fan motor)

Low pressure is measured at the compressor suction access fitting.

kW = Total system power

EXPANDED HEATING DATA (CONT.)

GPH1549M41*

LOW STAGE

	OUTDOOR AMBIENT TEMPERATURE																	
	65	60	55	50	47	45	40	35	30	25	20	17	15	10	5	0	-5	-10
MBh	40.0	37.8	35.6	33.3	31.8	30.8	28.6	26.4	21.8	20.1	18.5	17.5	16.9	15.1	13.4	11.7	10.0	8.2
ΔT	30.8	29.2	27.5	25.7	24.5	23.8	22.1	20.4	16.8	15.5	14.3	13.5	13.0	11.7	10.3	9.0	7.7	6.3
kW	3.04	2.98	2.92	2.86	2.83	2.80	2.74	2.69	2.81	2.74	2.68	2.64	2.62	2.55	2.49	2.43	2.36	2.30
Amps	11.5	10.8	10.2	9.7	9.4	9.3	8.8	8.5	8.2	7.9	7.6	7.5	7.4	7.1	6.8	6.5	6.1	5.7
COP	3.85	3.72	3.57	3.41	3.29	3.22	3.05	2.88	2.27	2.15	2.02	1.94	1.88	1.73	1.58	1.41	1.24	1.04
EER	13.1	12.7	12.2	11.6	11.2	11.0	10.4	9.8	7.8	7.3	6.9	6.6	6.4	5.9	5.4	4.8	4.2	3.6
HI PR	395	379	364	348	340	334	321	308	295	282	270	264	259	249	240	230	222	214
LO PR	139	129	121	111	105	101	93	83	75	67	59	54	52	44	38	32	28	22

GPH1549M41*

HIGH STAGE

	OUTDOOR AMBIENT TEMPERATURE																	
	65	60	55	50	47	45	40	35	30	25	20	17	15	10	5	0	-5	-10
MBh	57.9	54.8	51.6	48.2	46.0	44.6	41.4	38.2	31.9	29.4	27.1	25.6	24.6	22.1	19.6	17.1	14.6	11.9
ΔT	39.8	37.7	35.5	33.2	31.7	30.7	28.5	26.3	21.9	20.2	18.6	17.6	17.0	15.2	13.5	11.8	10.0	8.2
kW	3.99	3.91	3.83	3.75	3.70	3.66	3.59	3.51	3.53	3.44	3.36	3.31	3.28	3.20	3.12	3.03	2.95	2.87
Amps	20.2	18.8	17.7	16.8	16.3	16.0	15.2	14.5	14.0	13.4	12.9	12.6	12.5	11.9	11.2	10.7	10.0	9.2
COP	4.25	4.11	3.95	3.77	3.64	3.56	3.38	3.19	2.64	2.50	2.36	2.26	2.20	2.02	1.84	1.65	1.45	1.22
EER	14.5	14.0	13.5	12.9	12.4	12.2	11.6	10.9	9.0	8.5	8.1	7.7	7.5	6.9	6.3	5.6	4.9	4.2
HI PR	395	379	364	348	340	334	321	308	295	282	270	264	259	249	240	230	222	214
LO PR	143	133	125	114	108	104	96	85	77	69	60	56	54	46	39	33	29	23

GPH1560M41*

LOW STAGE

	OUTDOOR AMBIENT TEMPERATURE																	
	65	60	55	50	47	45	40	35	30	25	20	17	15	10	5	0	-5	-10
MBh	50.1	47.4	44.6	41.7	39.8	38.6	35.8	33.1	26.6	24.5	22.6	21.3	20.5	18.4	16.3	14.2	12.2	10.0
ΔT	34.3	32.5	30.6	28.6	27.3	26.5	24.6	22.7	18.2	16.8	15.5	14.6	14.1	12.6	11.2	9.8	8.3	6.8
kW	3.76	3.68	3.61	3.53	3.49	3.46	3.39	3.31	3.44	3.36	3.28	3.24	3.21	3.13	3.05	2.97	2.89	2.81
Amps	19.6	18.2	17.2	16.2	15.7	15.4	14.6	14.0	13.4	12.9	12.4	12.1	12.0	11.4	10.8	10.2	9.6	8.8
COP	3.90	3.76	3.62	3.45	3.34	3.26	3.09	2.92	2.26	2.13	2.01	1.93	1.87	1.72	1.57	1.40	1.23	1.04
EER	13.3	12.9	12.4	11.8	11.4	11.2	10.6	10.0	7.7	7.3	6.9	6.6	6.4	5.9	5.4	4.8	4.2	3.5
HI PR	391	375	361	345	337	330	318	305	292	279	268	261	257	247	237	228	220	212
LO PR	139	129	121	111	105	101	93	83	75	67	59	54	53	44	38	32	28	22

GPH1560M41*

HIGH STAGE

	OUTDOOR AMBIENT TEMPERATURE																	
	65	60	55	50	47	45	40	35	30	25	20	17	15	10	5	0	-5	-10
MBh	70.4	66.6	62.7	58.6	56.0	54.3	50.4	46.5	38.9	35.9	33.0	31.2	30.0	27.0	23.9	20.8	17.8	14.6
ΔT	36.2	34.3	32.3	30.2	28.8	27.9	25.9	23.9	20.0	18.5	17.0	16.0	15.5	13.9	12.3	10.7	9.1	7.5
kW	5.24	5.14	5.04	4.94	4.88	4.83	4.74	4.63	4.52	4.42	4.32	4.26	4.22	4.12	4.02	3.92	3.82	3.72
Amps	26.6	24.8	23.4	22.1	21.4	21.0	20.0	19.1	18.4	17.7	16.9	16.6	16.4	15.7	14.8	14.1	13.2	12.1
COP	3.93	3.79	3.64	3.48	3.36	3.29	3.11	2.94	2.52	2.38	2.24	2.14	2.08	1.92	1.74	1.56	1.36	1.15
EER	13.4	13.0	12.5	11.9	11.5	11.2	10.6	10.0	8.6	8.1	7.7	7.3	7.1	6.5	5.9	5.3	4.7	3.9
HI PR	411	394	379	362	354	347	333	320	306	293	281	274	269	259	249	239	230	222
LO PR	130	121	113	104	98	94	87	77	70	62	55	51	49	42	36	30	26	21

Notes:

Above information is for nominal CFM and 70-degree indoor dry bulb. Instantaneous capacity listed.

High pressure is measured at the liquid line access fitting.

Amps: Unit amps (comp.+ evaporator motor + condenser fan motor)

Low pressure is measured at the compressor suction access fitting.

kW = Total system power

AUXILIARY HEATING DATA

GPH1524M41*

CONDITIONS: 860 CFM; INDOOR AIR @ 70°F DB

OUTDOOR AMBIENT °F.	BASIC UNIT W/O AUX. HEAT		CAPACITY OF UNIT W/ KW OF AUX. HEAT				
	CAPACITY BTU/H	COP	5K	8K	10K	15K	20K
65	29.41	4.14	45.80	56.72	62.18	---	---
60	27.85	4.00	44.23	55.15	60.61	---	---
55	26.21	3.84	42.59	53.51	58.97	---	---
50	24.50	3.66	40.88	51.80	57.26	---	---
45	22.67	3.46	39.06	49.98	55.44	---	---
40	21.06	3.28	37.44	48.36	53.82	---	---
35	19.42	3.09	35.80	46.73	52.19	---	---
30	15.59	2.52	31.97	42.89	48.35	---	---
25	14.39	2.38	30.77	41.69	47.15	---	---
20	13.25	2.24	29.63	40.55	46.01	---	---
15	12.05	2.09	28.43	39.35	44.81	---	---
10	10.81	1.92	27.19	38.11	43.57	---	---
5	9.58	1.74	25.97	36.89	42.35	---	---
0	8.36	1.56	24.74	35.66	41.12	---	---
-5	7.13	1.36	23.51	34.43	39.90	---	---
-10	5.84	1.15	22.22	33.15	38.61	---	---

GPH1530M41*

CONDITIONS: 1000 CFM; INDOOR AIR @ 70°F DB

OUTDOOR AMBIENT °F.	BASIC UNIT W/O AUX. HEAT		CAPACITY OF UNIT W/ KW OF AUX. HEAT				
	CAPACITY BTU/H	COP	5K	8K	10K	15K	20K
65	34.44	4.36	51.51	61.75	68.57	85.64	---
60	32.61	4.21	49.67	59.91	66.74	83.80	---
55	30.69	4.04	47.75	57.99	64.82	81.88	---
50	28.69	3.86	45.75	55.99	62.82	79.88	---
45	26.55	3.65	43.62	53.85	60.68	77.75	---
40	24.66	3.36	41.73	51.96	58.79	75.86	---
35	22.74	3.26	39.81	50.05	56.87	73.94	---
30	18.81	2.70	35.88	46.12	52.94	70.01	---
25	17.37	2.55	34.43	44.67	51.50	68.56	---
20	15.99	2.40	33.06	43.29	50.12	67.19	---
15	9.89	2.24	26.95	37.19	44.02	61.08	---
10	8.87	2.06	25.94	36.18	43.00	60.07	---
5	7.87	1.87	24.93	35.17	42.00	59.06	---
0	6.86	1.67	23.93	34.16	40.99	58.06	---
-5	5.85	1.47	22.92	33.16	39.98	57.05	---
-10	7.05	1.23	24.12	34.36	41.18	58.25	---

GPH1536M41*

CONDITIONS: 1200 CFM; INDOOR AIR @ 70°F DB

OUTDOOR AMBIENT °F.	BASIC UNIT W/O AUX. HEAT		CAPACITY OF UNIT W/ KW OF AUX. HEAT				
	CAPACITY BTU/H	COP	5K	8K	10K	15K	20K
65	44.59	4.02	60.97	71.89	77.35	93.73	---
60	42.21	3.89	58.59	69.51	74.97	91.36	---
55	39.73	3.74	56.11	67.03	72.49	88.87	---
50	37.14	3.57	53.52	64.44	69.90	86.28	---
45	34.37	3.38	50.75	61.67	67.14	83.52	---
40	31.92	3.20	48.31	59.23	64.69	81.07	---
35	29.44	3.02	45.82	56.74	62.20	78.59	---
30	23.20	2.80	39.58	50.50	55.97	72.35	---
25	21.41	2.64	37.80	48.72	54.18	70.56	---
20	19.72	2.49	36.10	47.02	52.48	68.87	---
15	17.93	2.32	34.31	45.24	50.70	67.08	---
10	16.09	2.13	32.47	43.39	48.85	65.23	---
5	14.26	1.94	30.65	41.57	47.03	63.41	---
0	12.44	1.73	28.82	39.74	45.20	61.59	---
-5	10.61	1.52	27.00	37.92	43.38	59.76	---
-10	8.70	1.28	25.08	36.00	41.46	57.84	---

GPH1542M41*

CONDITIONS: 1250 CFM INDOOR AIR @ 70°F DB

OUTDOOR AMBIENT °F.	BASIC UNIT W/O AUX. HEAT		CAPACITY OF UNIT W/ KW OF AUX. HEAT				
	CAPACITY BTU/H	COP	5K	8K	10K	15K	20K
65	50.28	4.31	67.35	77.58	84.41	101.48	---
60	47.60	4.16	64.67	74.90	81.73	98.80	---
55	44.80	4.00	61.87	72.10	78.93	96.00	---
50	41.88	3.82	58.95	69.18	76.01	93.08	---
45	38.76	3.61	55.83	66.06	72.89	89.96	---
40	36.00	3.43	53.07	63.30	70.13	87.20	---
35	33.20	3.24	50.27	60.50	67.33	84.40	---
30	24.92	2.53	41.99	52.22	59.05	76.12	---
25	23.00	2.39	40.07	50.30	57.13	74.20	---
20	21.18	2.25	38.25	48.48	55.31	72.38	---
15	19.26	2.10	36.33	46.56	53.39	70.46	---
10	17.28	1.93	34.35	44.58	51.41	68.48	---
5	15.32	1.76	32.39	42.62	49.45	66.52	---
0	13.36	1.58	30.43	40.66	47.49	64.56	---
-5	11.40	1.38	28.47	38.70	45.53	62.60	---
-10	9.34	1.16	26.41	36.64	43.47	60.54	---

NOTES

- COP: Coefficient of performance
- To obtain BTU capacity of the unit with Kw of auxiliary heat, multiply by 1000 (example 39.01 x 1000 = 39,010 BTU'S)

AUXILIARY HEATING DATA (CONT.)

GPB1543M41*

CONDITIONS: 1350 CFM; INDOOR AIR @ 70°F DB

OUTDOOR AMBIENT °F.	BASIC UNIT W/O AUX. HEAT		CAPACITY OF UNIT W/ KW OF AUX. HEAT				
	CAPACITY BTU/H	COP	5K	8K	10K	15K	20K
65	50.28	4.31	67.35	77.58	84.41	101.48	---
60	47.60	4.16	64.67	74.90	81.73	98.80	---
55	44.80	4.00	61.87	72.10	78.93	96.00	---
50	41.88	3.82	58.95	69.18	76.01	93.08	---
45	38.76	3.61	55.83	66.06	72.89	89.96	---
40	36.00	3.43	53.07	63.30	70.13	87.20	---
35	33.20	3.24	50.27	60.50	67.33	84.40	---
30	24.92	2.53	41.99	52.22	59.05	76.12	---
25	23.00	2.39	40.07	50.30	57.13	74.20	---
20	21.18	2.25	38.25	48.48	55.31	72.38	---
15	19.26	2.10	36.33	46.56	53.39	70.46	---
10	17.28	1.93	34.35	44.58	51.41	68.48	---
5	15.32	1.76	32.39	42.62	49.45	66.52	---
-5	11.40	1.38	28.47	38.70	45.53	62.60	---
-10	9.34	1.16	26.41	36.64	43.47	60.54	---

GPB1548M41*

CONDITIONS: 1700 CFM INDOOR AIR @ 70°F DB

OUTDOOR AMBIENT °F.	BASIC UNIT W/O AUX. HEAT		CAPACITY OF UNIT W/ KW OF AUX. HEAT				
	CAPACITY BTU/H	COP	5K	8K	10K	15K	20K
65	57.38	4.00	73.76	84.69	90.15	106.53	122.91
60	54.32	3.86	70.71	81.63	87.09	103.47	119.85
55	51.13	3.70	67.51	78.43	83.89	100.28	116.66
50	47.80	3.53	64.18	75.10	80.56	96.94	113.33
45	44.23	3.34	60.62	71.54	77.00	93.38	109.76
40	41.09	3.16	57.47	68.39	73.85	90.23	106.61
35	37.89	2.98	54.27	65.19	70.65	87.04	103.42
30	30.65	2.45	47.03	57.96	63.42	79.80	96.18
25	28.29	2.32	44.67	55.59	61.05	77.44	93.82
20	26.05	2.18	42.43	53.36	58.82	75.20	91.58
15	23.69	2.03	40.07	50.99	56.45	72.84	89.22
10	21.25	1.86	37.64	48.56	54.02	70.40	86.78
5	18.84	1.69	35.23	46.15	51.61	67.99	84.37
-5	14.02	1.32	30.40	41.33	46.79	63.17	79.55
-10	11.49	1.11	27.87	38.79	44.25	60.64	77.02

GPB1549M41*

CONDITIONS: 1700 CFM INDOOR AIR @ 70°F DB

OUTDOOR AMBIENT °F.	BASIC UNIT W/O AUX. HEAT		CAPACITY OF UNIT W/ KW OF AUX. HEAT				
	CAPACITY BTU/H	COP	5K	8K	10K	15K	20K
65	57.38	4.00	73.76	84.69	90.15	106.53	122.91
60	54.32	3.86	70.71	81.63	87.09	103.47	119.85
55	51.13	3.70	67.51	78.43	83.89	100.28	116.66
50	47.80	3.53	64.18	75.10	80.56	96.94	113.33
45	44.23	3.34	60.62	71.54	77.00	93.38	109.76
40	41.09	3.16	57.47	68.39	73.85	90.23	106.61
35	37.89	2.98	54.27	65.19	70.65	87.04	103.42
30	30.65	2.45	47.03	57.96	63.42	79.80	96.18
25	28.29	2.32	44.67	55.59	61.05	77.44	93.82
20	26.05	2.18	42.43	53.36	58.82	75.20	91.58
15	23.69	2.03	40.07	50.99	56.45	72.84	89.22
10	21.25	1.86	37.64	48.56	54.02	70.40	86.78
5	18.84	1.69	35.23	46.15	51.61	67.99	84.37
0	16.43	1.51	32.82	43.74	49.20	65.58	81.96
-5	14.02	1.32	30.40	41.33	46.79	63.17	79.55
-10	11.49	1.11	27.87	38.79	44.25	60.64	77.02

GPB1560M41*

CONDITIONS: 1800 CFM; INDOOR AIR @ 70°F DB

OUTDOOR AMBIENT °F.	BASIC UNIT W/O AUX. HEAT		CAPACITY OF UNIT W/ KW OF AUX. HEAT				
	CAPACITY BTU/H	COP	5K	8K	10K	15K	20K
65	70.39	3.93	86.77	97.70	103.16	119.54	135.92
60	66.64	3.79	83.02	93.94	99.40	115.79	132.17
55	62.72	3.64	79.10	90.02	95.48	111.87	128.25
50	58.63	3.48	75.01	85.94	91.40	107.78	124.16
45	54.26	3.29	70.65	81.57	87.03	103.41	119.79
40	50.40	3.11	66.78	77.70	83.16	99.55	115.93
35	46.48	2.94	62.86	73.78	79.24	95.63	112.01
30	38.88	2.52	55.26	66.18	71.64	88.02	104.40
25	35.88	2.38	52.26	63.18	68.64	85.03	101.41
20	33.04	2.24	49.42	60.34	65.81	82.19	98.57
15	30.05	2.08	46.43	57.35	62.81	79.19	95.58
10	26.96	1.92	43.34	54.26	59.72	76.10	92.49
5	23.90	1.74	40.28	51.20	56.66	73.05	89.43
0	20.84	1.56	37.22	48.15	53.61	69.99	86.37
-5	17.78	1.36	34.17	45.09	50.55	66.93	83.31
-10	14.57	1.15	30.95	41.87	47.34	63.72	80.10

NOTES

- COP: Coefficient of performance
- To obtain BTU capacity of the unit with Kw of auxiliary heat, multiply by 1000 (example 39.01 x 1000 = 39,010 BTU'S)

HEAT KIT ELECTRICAL DATA (BLOWER ONLY, HEAT MODE)

MODEL & HEAT KIT USAGE	CIRCUIT #1		CIRCUIT #2		ACTUAL KW / BTU@ 240V
	MCA ¹	MOP ²	MCA ¹	MOP ²	
GPH1524M41AA	4.3 / 4.3	--	--	--	--
HKR-05*, HKR-05C*	24 / 27	30 / 30	--	--	4.75 / 16,200
HKR-08*, HKR-08C*	34 / 39	40 / 40	--	--	7.0 / 23,800
HKR-10*, HKR-10C*	45 / 52	60 / 60	--	--	9.5 / 32,400
GPH1530M41AA	4.3 / 4.3	--	--	--	--
HKR-05*, HKR-05C*	24 / 27	30 / 30	--	--	4.75 / 16,200
HKR-08*, HKR-08C*	34 / 39	40 / 40	--	--	7.0 / 23,800
HKR-10*, HKR-10C*	45 / 52	60 / 60	--	--	9.5 / 32,400
HKR-15*, HKR-15C*	45 / 52	60 / 60	22 / 25	30 / 30	14.25 / 48,600
GPH1536M41AA	4.3 / 4.3	--	--	--	--
HKR-05*, HKR-05C*	24 / 27	30 / 30	--	--	4.75 / 16,200
HKR-08*, HKR-08C*	34 / 39	40 / 40	--	--	7.0 / 23,800
HKR-10*, HKR-10C*	45 / 52	60 / 60	--	--	9.5 / 32,400
HKR-15*, HKR-15C*	45 / 52	60 / 60	22 / 25	30 / 30	14.25 / 48,600
GPH1542M41AA	4.3 / 4.3	--	--	--	--
HKR-05*, HKR-05C*	24 / 27	30 / 30	--	--	4.75 / 16,200
HKR-08*, HKR-08C*	34 / 39	40 / 40	--	--	7.0 / 23,800
HKR-10*, HKR-10C*	45 / 52	60 / 60	--	--	9.5 / 32,400
HKR-15*, HKR-15C*	45 / 52	60 / 60	22 / 25	30 / 30	14.25 / 48,600
GPH1543M41* / *A	2.9/2.9	--	--	--	--
HKR05A,CA	24 / 27	30 / 30	--	--	4.75 / 16,200
HKR08A,CA	34 / 39	40 / 40	--	--	7.0 / 23,800
HKR10A,CA	45 / 52	60 / 60	--	--	9.5 / 32,400
HKR15A,CA	45 / 52	60 / 60	22 / 25	30 / 30	14.25 / 48,600
GPH1548M41AA	5.8 / 5.8	--	--	--	--
HKR-05*, HKR-05C*	25 / 28	30 / 30	--	--	4.75 / 16,200
HKR-08*, HKR-08C*	38 / 40	40 / 40	--	--	7.0 / 23,800
HKR-10*, HKR-10C*	49 / 56	60 / 60	--	--	9.5 / 32,400
HKR-15*, HKR-15C*	49 / 56	60 / 60	22 / 25	30 / 30	14.25 / 48,600
HKR-20*, HKR-20C*	49 / 56	60 / 60	43 / 49	60 / 60	19.5 / 66,500
GPH1549M41* / *A	2.9/2.9	--	--	--	--
HKR05A,CA	25 / 28	30 / 30	----	----	4.75 / 16,200
HKR08A,CA	34 / 40	40 / 40	----	----	7.00 / 23,800
HKR10A,CA	46 / 53	60 / 60	----	----	9.50 / 32,400
HKR15A,CA	46 / 52	60 / 60	22 / 25	30 / 30	14.25 / 48,600
HKR20A,CA	46 / 52	60 / 60	43 / 49	60 / 60	19.50 / 66,500
GPH1560M41AA	7.0 / 7.0	--	--	--	--
HKR-05*, HKR-05C*	29 / 30	30 / 30	--	--	4.75 / 16,200
HKR-08*, HKR-08C*	39 / 40	40 / 40	--	--	7.0 / 23,800
HKR-10*, HKR-10C*	51 / 58	60 / 60	--	--	9.5 / 32,400
HKR-15*, HKR-15C*	51 / 58	60 / 60	22 / 25	30 / 30	14.25 / 48,600
HKR-20*, HKR-20C*	51 / 58	60 / 60	43 / 49	60 / 60	19.5 / 66,500

¹ Minimum Circuit Ampacity @ 460 V

² Maximum Overcurrent Protection device @ 460 V

* Revision level that may or may not be designated

C Circuit Breaker option

DIMENSIONS

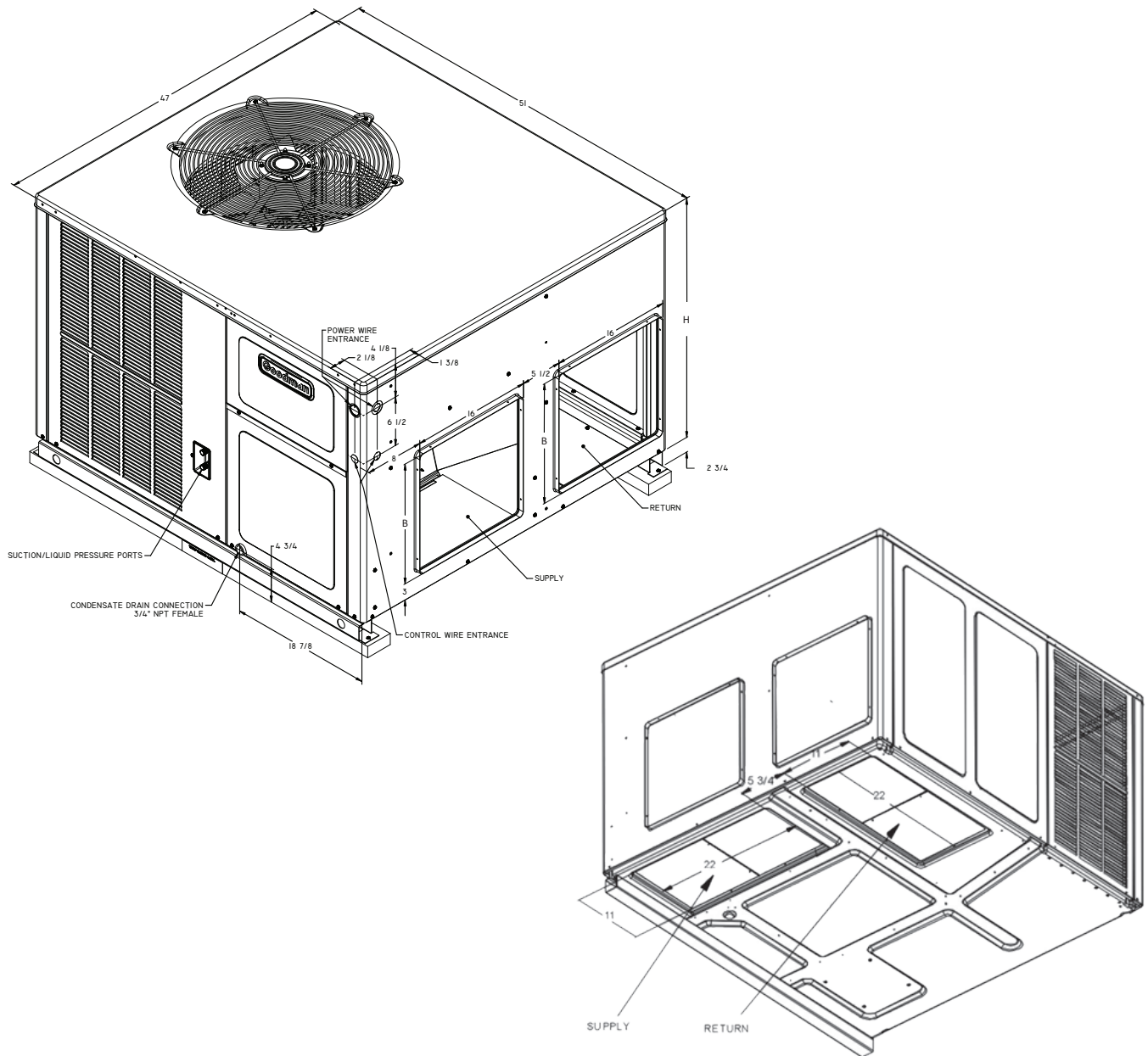

MODEL	MED.	LARGE	W"	D'	H'	B	H
GPH1524M41A	X		47	51	34 3/4	16"	32 1/2"
GPH1530M41A	X		47	51	34 3/4	16"	32 1/2"
GPH1536M41A	X		47	51	34 3/4	16"	32 1/2"
GPH1542M41A	X		47	51	34 3/4	16"	32 1/2"
GPH1543M41A		X	47	51	42 3/4	18"	40"
GPH1548M41A		X	47	51	42 3/4	18"	40"
GPH1549M41A		X	47	51	42 3/4	18"	40"
GPH1560M41A		X	47	51	42 3/4	18"	40"

WIRING DIAGRAM — GPH1524-36M41AA

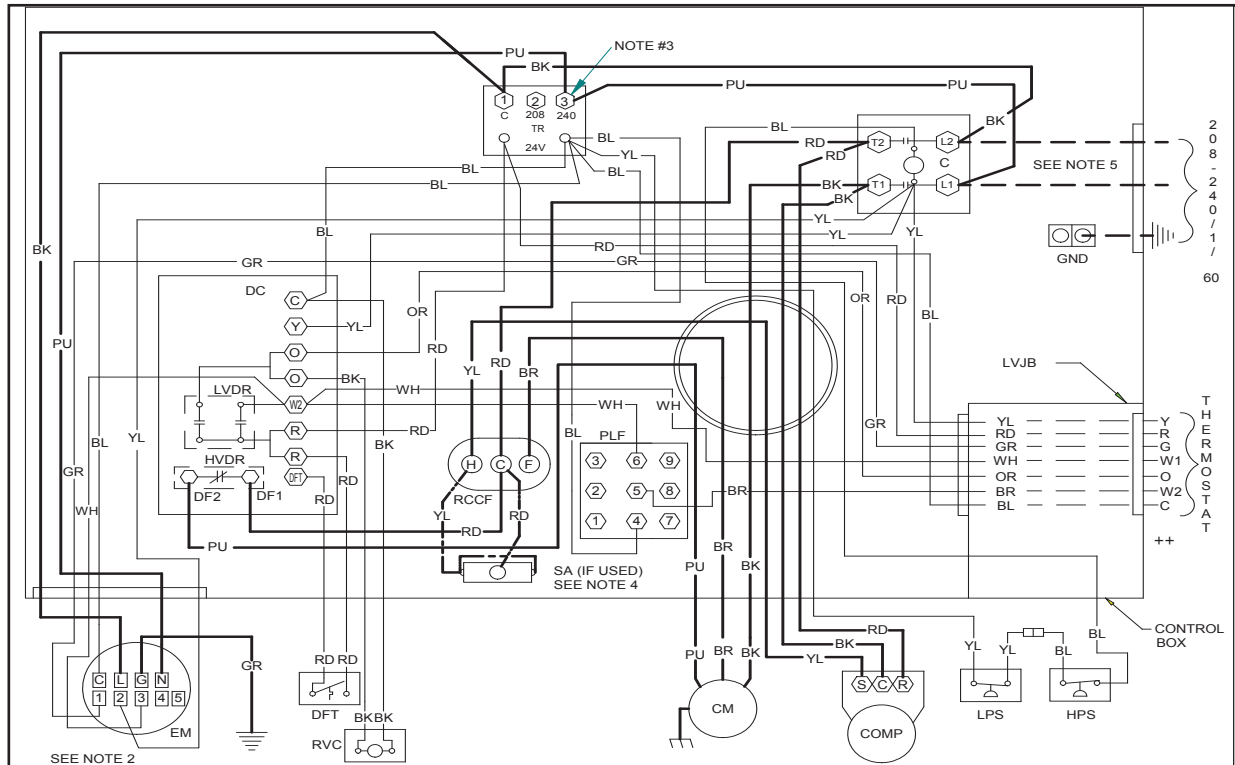

SEE NOTE 2

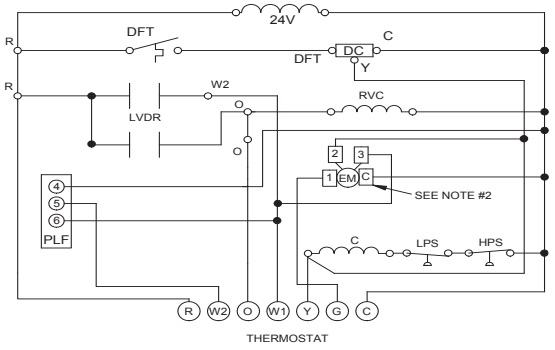
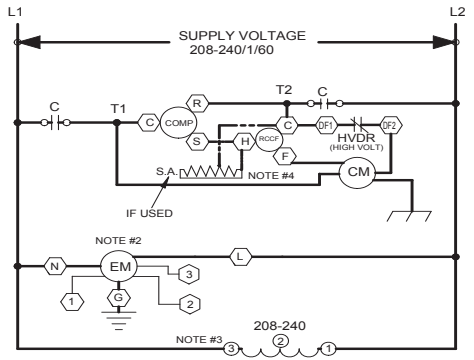

COMPONENT LEGEND

- C CONTACTOR
- CM CONDENSER MOTOR
- COMP COMPRESSOR
- DC DEFROST CONTROL
- DFT DEFROST THERMOSTAT
- EM EVAPORATOR MOTOR
- GND EQUIPMENT GROUND
- HPS HIGH PRESSURE SWITCH
- HVDR HIGH VOLTAGE DEFROST RELAY
- LPS LOW PRESSURE SWITCH
- LVDR LOW VOLTAGE DEFROST RELAY
- LVJB LOW VOLTAGE JUNCTION BOX
- PLF FEMALE PLUG / CONNECTOR
- RVC REVERSING VALVE COIL
- RCCF RUN CAPACITOR FOR COMPRESSOR AND FAN
- SA START ASSIST
- TR TRANSFORMER

FACTORY WIRING

- LINE VOLTAGE
- LOW VOLTAGE
- OPTIMAL HIGH VOLTAGE
- VOLTAGE

FIELD WIRING

- HIGH VOLTAGE
- LOW VOLTAGE

WIRE CODE

- BK BLACK
- BL BLUE
- BR BROWN
- GR GREEN
- OR ORANGE
- PU PURPLE
- RD RED
- WH WHITE
- YL YELLOW

NOTES:

1. REPLACEMENT WIRE MUST BE SAME SIZE AND TYPE INSULATION AS ORIGINAL (AT LEAST 105°C) USE COPPER CONDUCTOR ONLY.
 2. TO CHANGE EVAPORATOR MOTOR SPEED MOVE WHITE AND YELLOW LEADS FROM EM"2" AND "3" TO "4" AND "5". IF BOTH LEADS ARE ENERGIZED, THE HIGHER SPEED SETTING IS USED.
 3. FOR 208 VOLT TRANSFORMER OPERATION MOVE PURPLE WIRES FROM TERMINAL 3 TO TERMINAL 2 ON TRANSFORMER.
 4. START ASSIST FACTOR EQUIPED WHEN REQUIRED
 5. USE COPPER CONDUCTORS ONLY
- ++ USE N.E.C. CLASS 2 WIRE

SEE UNIT RATING PLATE FOR TYPE AND SIZE OF OVER CURRENT PROTECTION

208-240/1/60 0140G00592

Wiring is subject to change. Always refer to the wiring diagram or the unit for the most up-to-date wiring.

WARNING

High Voltage: Disconnect all power before servicing or installing this unit. Multiple power sources may be present. Failure to do so may cause property damage, personal injury, or death.

WIRING DIAGRAM — GPH1542-60M41AA

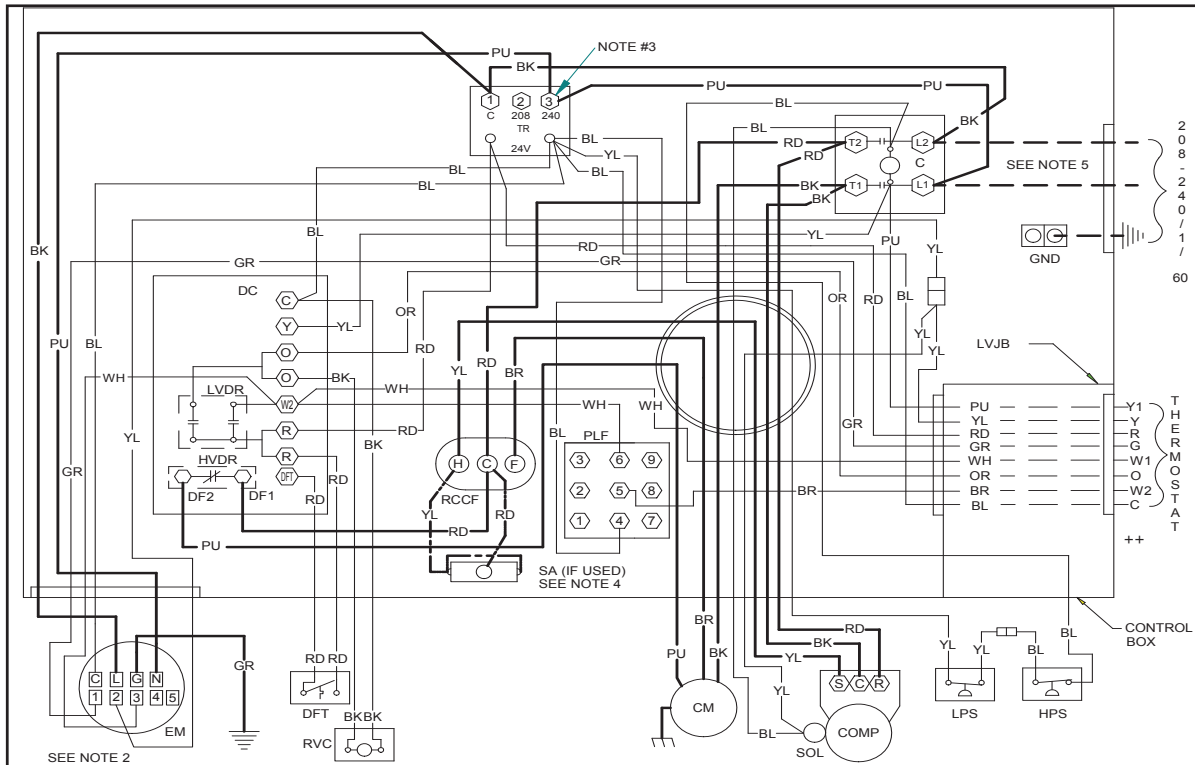

SEE NOTE 2

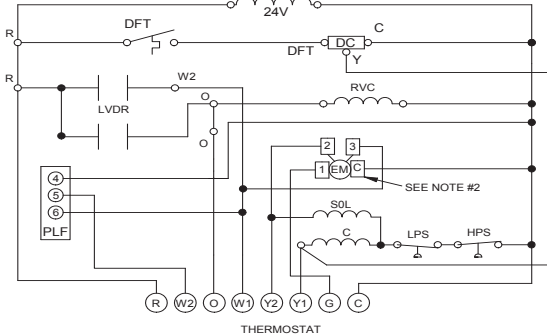
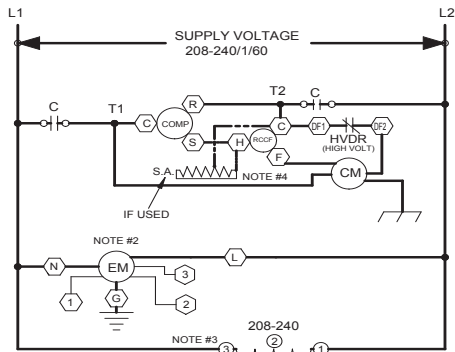

COMPONENT LEGEND

- C CONTACTOR
- CM CONDENSER MOTOR
- COMP COMPRESSOR
- DC DEFROST CONTROL
- DFT DEFROST THERMOSTAT
- EM EVAPORATOR MOTOR
- GND EQUIPMENT GROUND
- HPS HIGH PRESSURE SWITCH
- HVDR HIGH VOLTAGE DEFROST RELAY
- LPS LOW PRESSURE SWITCH
- LVDR LOW VOLTAGE DEFROST RELAY
- LVJB LOW VOLTAGE JUNCTION BOX
- PLF FEMALE PLUG / CONNECTOR
- RVC REVERSING VALVE COIL
- RCCF RUN CAPACITOR FOR COMPRESSOR AND FAN
- SA START ASSIST
- SOL HI STAGE SOLENOID TRANSFORMER
- TR TRANSFORMER

FACTORY WIRING

- LINE VOLTAGE
- LOW VOLTAGE
- OPTIMAL HIGH VOLTAGE
- VOLTAGE

FIELD WIRING

- HIGH VOLTAGE
- LOW VOLTAGE

WIRE CODE

- BK BLACK
- BL BLUE
- BR BROWN
- GR GREEN
- OR ORANGE
- PU PURPLE
- RD RED
- WH WHITE
- YL YELLOW

NOTES:

1. REPLACEMENT WIRE MUST BE SAME SIZE AND TYPE INSULATION AS ORIGINAL (AT LEAST 105°C) USE COPPER CONDUCTOR ONLY.
2. TO CHANGE EVAPORATOR MOTOR SPEED MOVE WHITE AND YELLOW LEADS FROM EM"2" AND "3" TO "4" AND "5". IF BOTH LEADS ARE ENERGIZED, THE HIGHER SPEED SETTING IS USED.
3. FOR 208 VOLT TRANSFORMER OPERATION MOVE PURPLE WIRES FROM TERMINAL 3 TO TERMINAL 2 ON TRANSFORMER.
4. START ASSIST FACTOR EQUIPED WHEN REQUIRED
5. USE COPPER CONDUCTORS ONLY
- ++ USE N.E.C. CLASS 2 WIRE

SEE UNIT RATING PLATE FOR TYPE AND SIZE OF OVER CURRENT PROTECTION

208-240/1/60 0140G00593

Wiring is subject to change. Always refer to the wiring diagram or the unit for the most up-to-date wiring.



High Voltage: Disconnect all power before servicing or installing this unit. Multiple power sources may be present. Failure to do so may cause property damage, personal injury, or death.



WIRING DIAGRAM — GPH1549-60M41AB

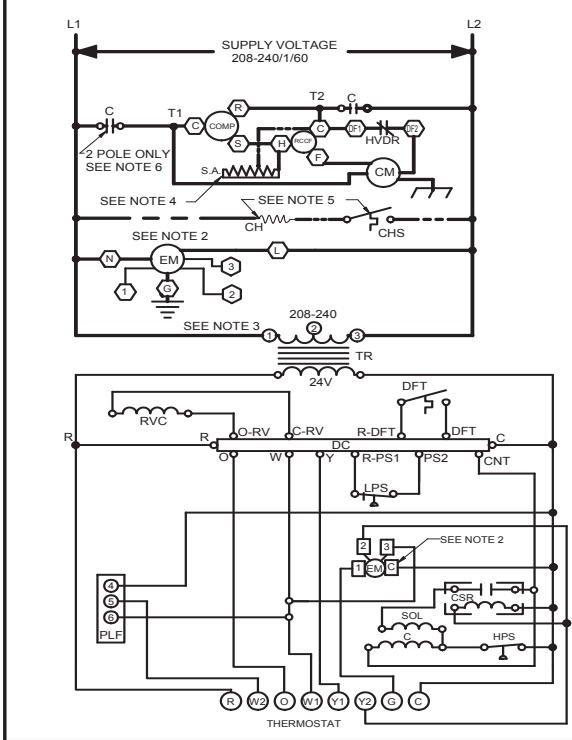
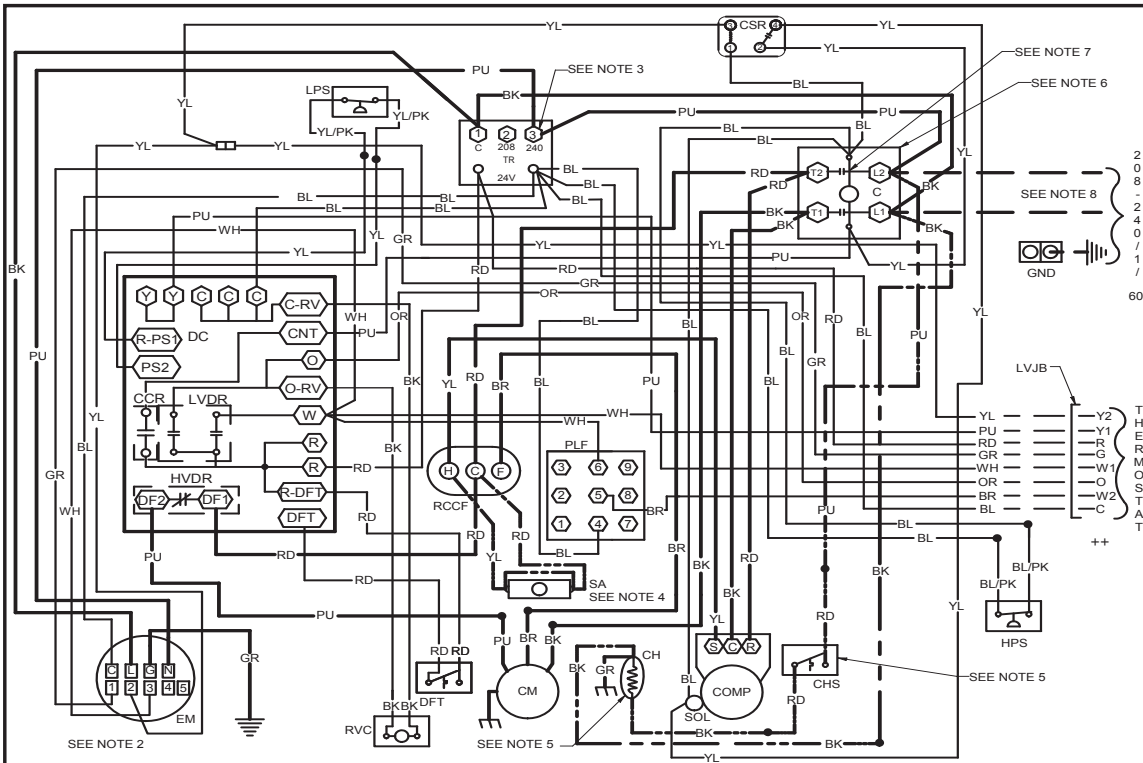

COMPONENT LEGEND

C	CONTACTOR	---	FACTORY WIRING
CCR	COMPRESSOR CONTACTOR RELAY	---	LINE VOLTAGE
CH	CRANKCASE HEATER	---	LOW VOLTAGE
CHS	CRANKCASE HEATER SWITCH	---	OPTIONAL HIGH VOLTAGE
CM	CONDENSER MOTOR	---	VOLTAGE
COMP	COMPRESSOR	---	FIELD WIRING
CSR	COMPRESSOR SOLENOID RELAY	---	HIGH VOLTAGE
DC	DEFROST CONTROL	---	LOW VOLTAGE
DFT	DEFROST THERMOSTAT	---	
EM	EVAPORATOR MOTOR	---	
GND	EQUIPMENT GROUND	---	
HPS	HIGH PRESSURE SWITCH	---	
HVDR	HIGH VOLTAGE DEFROST RELAY	---	
LPS	LOW PRESSURE SWITCH	---	
LVDR	LOW VOLTAGE DEFROST RELAY	---	
LVJB	LOW VOLTAGE JUNCTION BOX	---	
PLF	FEMALE PLUG / CONNECTOR	---	
RVC	REVERSING VALVE COIL	---	
RCCF	RUN CAPACITOR FOR COMPRESSOR AND FAN	---	
SA	START ASSIST AND FAN	---	
SOL	HI STAGE SOLENOID	---	
TR	TRANSFORMER	---	

WIRE CODE

BK	BLACK
BL	BLUE
BR	BROWN
GR	GREEN
OR	ORANGE
PU	PURPLE
RD	RED
WH	WHITE
YL	YELLOW

NOTES:

- REPLACEMENT WIRE MUST BE SAME SIZE AND TYPE INSULATION AS ORIGINAL (AT LEAST 105°C) USE COPPER CONDUCTOR ONLY.
- TO CHANGE EVAPORATOR MOTOR SPEED MOVE WHITE AND YELLOW LEADS FROM EM"2" AND "3" TO "4" AND "5". IF BOTH LEADS ARE ENERGIZED, THE HIGHER SPEED SETTING IS USED.
- FOR 208 VOLT TRANSFORMER OPERATION MOVE PURPLE WIRES FROM TERMINAL 3 TO TERMINAL 2 ON TRANSFORMER.
- START ASSIST FACTORY EQUIPPED WHEN REQUIRED
- CRANKCASE HEATER AND CRANKCASE HEATER SWITCH FACTORY EQUIPPED WHEN REQUIRED.
- DOUBLE POLE CONTACTOR SHOWN. SINGLE POLE CONTACTOR COULD BE FACTORY EQUIPPED AS AN ALTERNATE CONFIGURATION.
- COMMON SIDE OF CONTACTOR CAN NOT BE GROUNDED OR CONNECTED TO ANY OTHER COMMON (24V).
- USE COPPER CONDUCTORS ONLY
- USE N.E.C. CLASS 2 WIRE

SEE UNIT RATING PLATE FOR TYPE AND SIZE OF OVER CURRENT PROTECTION

208-240/1/60 0140G01644-A

WARNING

High Voltage: Disconnect all power before servicing or installing this unit. Multiple power sources may be present. Failure to do so may cause property damage, personal injury, or death.

Wiring is subject to change. Always refer to the wiring diagram or the unit for the most up-to-date wiring.

