

# **Goodman**<sup>®</sup> TECHNICAL MANUAL

## **GMH8 33-3/8" 80% Gas Furnace 80% AFUE, 2-Stage (Convertible), Multi-Speed, Upflow/Horizontal**

- Refer to Service Manual RS6610004 for installation, operation, and troubleshooting information.
- All safety information must be followed as provided in the Service Manual.
- Refer to the appropriate Parts Catalog for part number information.
- Model numbers listed on page 3.

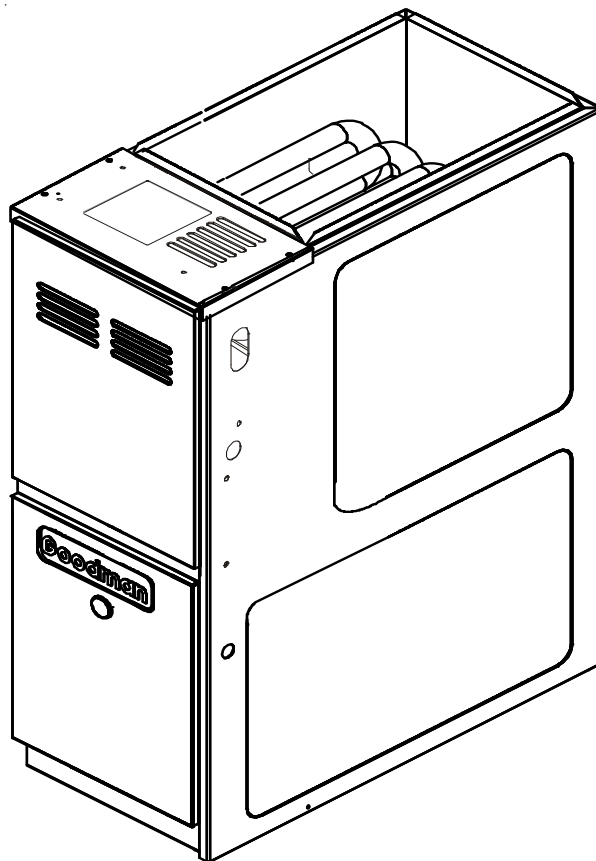

This manual is to be used by qualified, professionally trained HVAC technicians only. Goodman does not assume any responsibility for property damage or personal injury due to improper service procedures or services performed by an unqualified person.



Copyright ©2009-2010 Goodman Manufacturing Company, L.P.

RT6621018r1  
April 2010

# PRODUCT IDENTIFICATION

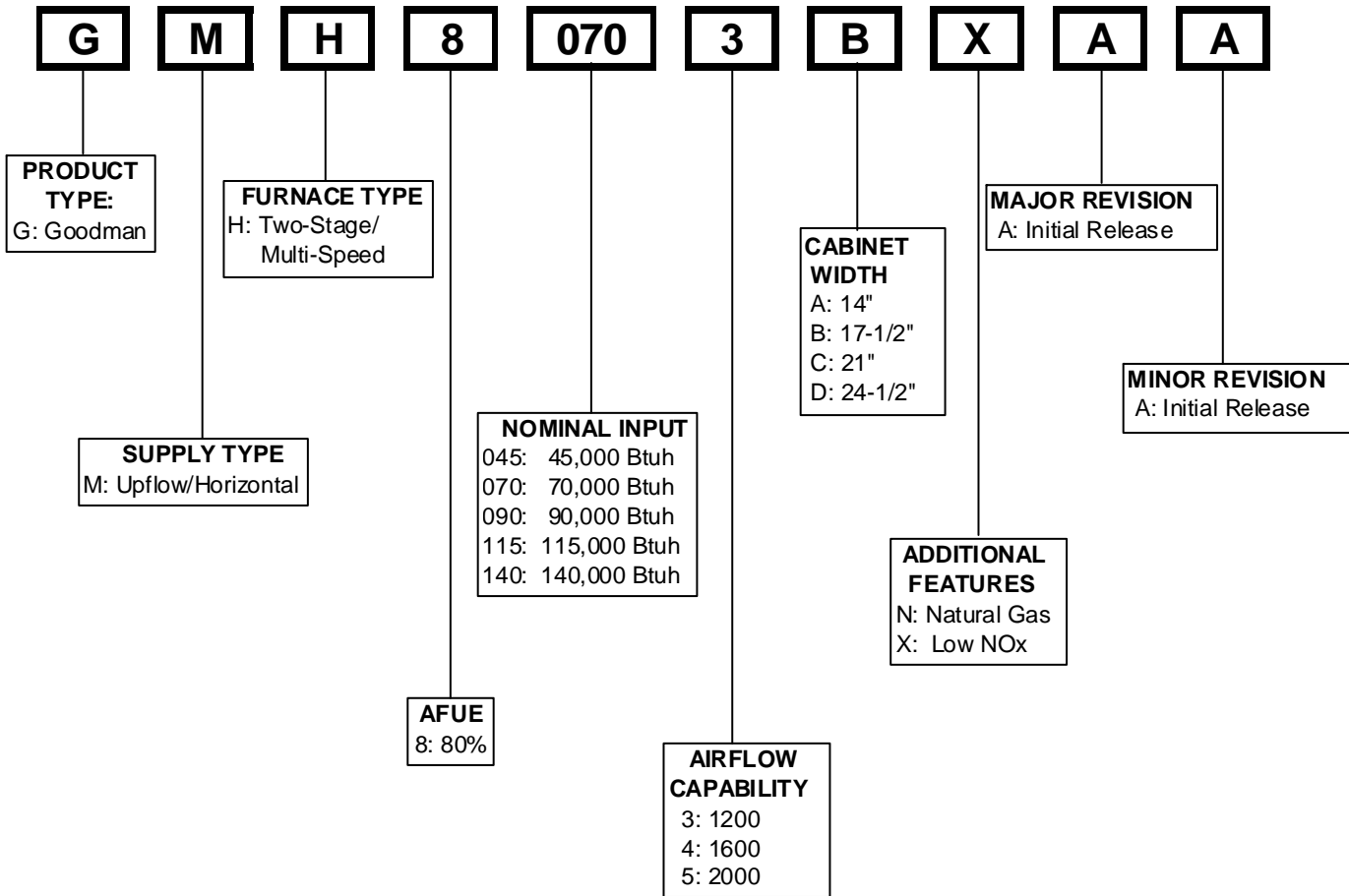
The model and manufacturing number are used for positive identification of component parts used in manufacturing. Please use these numbers when requesting service or parts information.



 **WARNING** **HIGH VOLTAGE!** Disconnect ALL power before servicing or installing this unit. Multiple power sources may be present. Failure to do so may cause property damage, personal injury or death. 

 **WARNING** Goodman will not be responsible for any injury or property damage arising from improper service or service procedures. If you install or perform service on this unit, you assume responsibility for any personal injury or property damage which may result. Many jurisdictions require a license to install or service heating and air conditioning equipment.

 **WARNING** Installation and repair of this unit should be performed ONLY by individuals meeting the requirements of an "entry level technician", at a minimum, as specified by the Air-Conditioning, Heating, and Refrigeration Institute (AHRI). Attempting to install or repair this unit without such background may result in product damage, personal injury or death.

# PRODUCT IDENTIFICATION

The model and manufacturing number are used for positive identification of component parts used in manufacturing. Please use these numbers when requesting service or parts information.

- <sup>1</sup> GMH80453ANC\*
- <sup>1</sup> GMH80703ANC\*
- <sup>1</sup> GMH80704BNC\*
- GMH80903BNC\*
- <sup>1</sup> GMH80904BNC\*
- <sup>1</sup> GMH80905CNC\*
- <sup>1</sup> GMH81155CNC\*
- <sup>1</sup> GMH81405DNC\*

<sup>1</sup> Units with low NOx models available.



The United States Environmental Protection Agency (“EPA”) has issued various regulations regarding the introduction and disposal of refrigerants introduced into this unit. Failure to follow these regulations may harm the environment and can lead to the imposition of substantial fines. These regulations may vary by jurisdiction. Should questions arise, contact your local EPA office.



Do not connect or use any device that is not design certified by Goodman for use with this unit. Serious property damage, personal injury, reduced unit performance and/or hazardous conditions may result from the use of such non-approved devices.



To prevent the risk of property damage, personal injury, or death, do not store combustible materials or use gasoline or other flammable liquids or vapors in the vicinity of this appliance.

# PRODUCT DESIGN

## General Operation

The GMH8 furnaces are equipped with an electronic ignition device used to light the burners and an induced draft blower to exhaust combustion products.

An interlock switch prevents furnace operation if the blower door is not in place. Keep the blower access door in place except for inspection and maintenance.

This furnace is also equipped with a self-diagnosing electronic control module. In the event a furnace component is not operating properly, the control module LED will flash on and off in a factory-programmed sequence, depending on the problem encountered. This light can be viewed through the observation window in the blower access door. Refer to the *Troubleshooting Chart* for further explanation of the LED codes and *Abnormal Operation - Integrated Ignition Control* section in the Service Instructions for an explanation of the possible problem.

The rated heating capacity of the furnace should be greater than or equal to the total heat loss of the area to be heated. The total heat loss should be calculated by an approved method or in accordance with "ASHRAE Guide" or "Manual J-Load Calculations" published by the Air Conditioning Contractors of America.

\*Obtain from: American National Standards Institute 1430 Broadway New York, NY 10018

## Location Considerations

- The furnace should be as centralized as is practical with respect to the air distribution system.
- Do not install the furnace directly on carpeting, tile, or combustible material other than wood flooring.
- When suspending the furnace from rafters or joists, use 3/8" threaded rod and 2" x 2" x 3/8" angle as shown in the Installation and Service Instructions. The length of the rod will depend on the application and clearance necessary.
- When installed in a residential garage, the furnace must be positioned so the burners and ignition source are located not less than 18 inches (457 mm) above the floor and protected from physical damage by vehicles.



**TO PREVENT POSSIBLE PERSONAL INJURY OR DEATH DUE TO ASPHYXIATION, THIS FURNACE MUST BE CATEGORY I VENTED. DO NOT VENT USING CATEGORY III VENTING.**

1. Category I Venting is venting at a non-positive pressure. A furnace vented as Category I is considered a fan-assisted appliance and the vent system does not have to be "gas tight." **NOTE:** Single stage gas furnaces with induced draft blowers draw products of combustion through a heat exchanger allowing, in some instances, common venting with natural draft appliances (i.e. water heaters). All installations must be vented in accordance with National Fuel Gas Code NFPA 54/ANSI Z223.1 - latest edition. In Canada, the furnaces must be vented in accordance with the National Standard of Canada, CAN/CSA B149.1 and CAN/CSA B149.2 - latest editions and amendments.
- NOTE:** The vertical height of the Category I venting system must be at least as great as the horizontal length of the venting system.
2. Line voltage wiring can enter through the right or left side of the furnace. Low voltage wiring can enter through the right or left side of furnace.
  3. Conversion kits for propane gas and high altitude natural and propane gas operation are available. See High Altitude Derate chart for details.

# PRODUCT DESIGN

## Accessibility Clearances (Minimum)

Unobstructed front clearance of 24" for servicing is recommended.

**MINIMUM CLEARANCE TO COMBUSTIBLE MATERIALS - INCHES**

Sides	Rear	Front*	Vent		Top
			SW	B	
1	0	3	6	1	1

\* 24" clearance for serviceability recommended.

\*\* Single Wall Vent (SW) to be used only as a connector.

Refer to the venting tables outlined in the Installation Manual for additional venting requirements.

**Note:** In all cases accessibility clearance shall take precedence over clearances from the enclosure where accessibility clearances are greater. All dimensions are given in inches.

## High Altitude Derate

When this furnace is installed at high altitude, the appropriate High Altitude orifice kit must be installed. This is required due to the natural reduction in the density of both the gas fuel and combustion air as altitude increases. The kit will provide the proper design certified input rate within the specified altitude range.

INPUT PER BURNER - 22,500 BTUH NATURAL GAS / 20,000 BTUH L.P.								
	ELEVATION ABOVE SEA-LEVEL (FEET)							
	2000	3000	4000	4500	5000	6000	7000	8000
US BURNER ORIFICE	44/55	44/55	45/56		45/56	46/57	47/58	47/58
CANADA BURNER ORIFICE	44/55			47/57				

**HA-02 HIGH ALTITUDE CONVERSION KIT REQUIRED**

Tabled data is based upon the furnace input being reduced for altitudes above sea level. U.S. 4% per 1,000 feet. Canada 10% derate for 2,000-4,000 feet.

High altitude kits are purchased according to the installation altitude and usage of either natural or propane gas. Refer to the chart above for a tabular listing of appropriate altitude ranges and corresponding manufacturer's high altitude Natural Gas and Propane Gas kits. For a tabular listing of appropriate altitude ranges and corresponding manufacturer's High Altitude Pressure Switch kits, refer to either the *Pressure Switch Trip Points & Usage Chart* in this manual or the *Accessory Charts* in Service Instructions.

# COMPONENT IDENTIFICATION

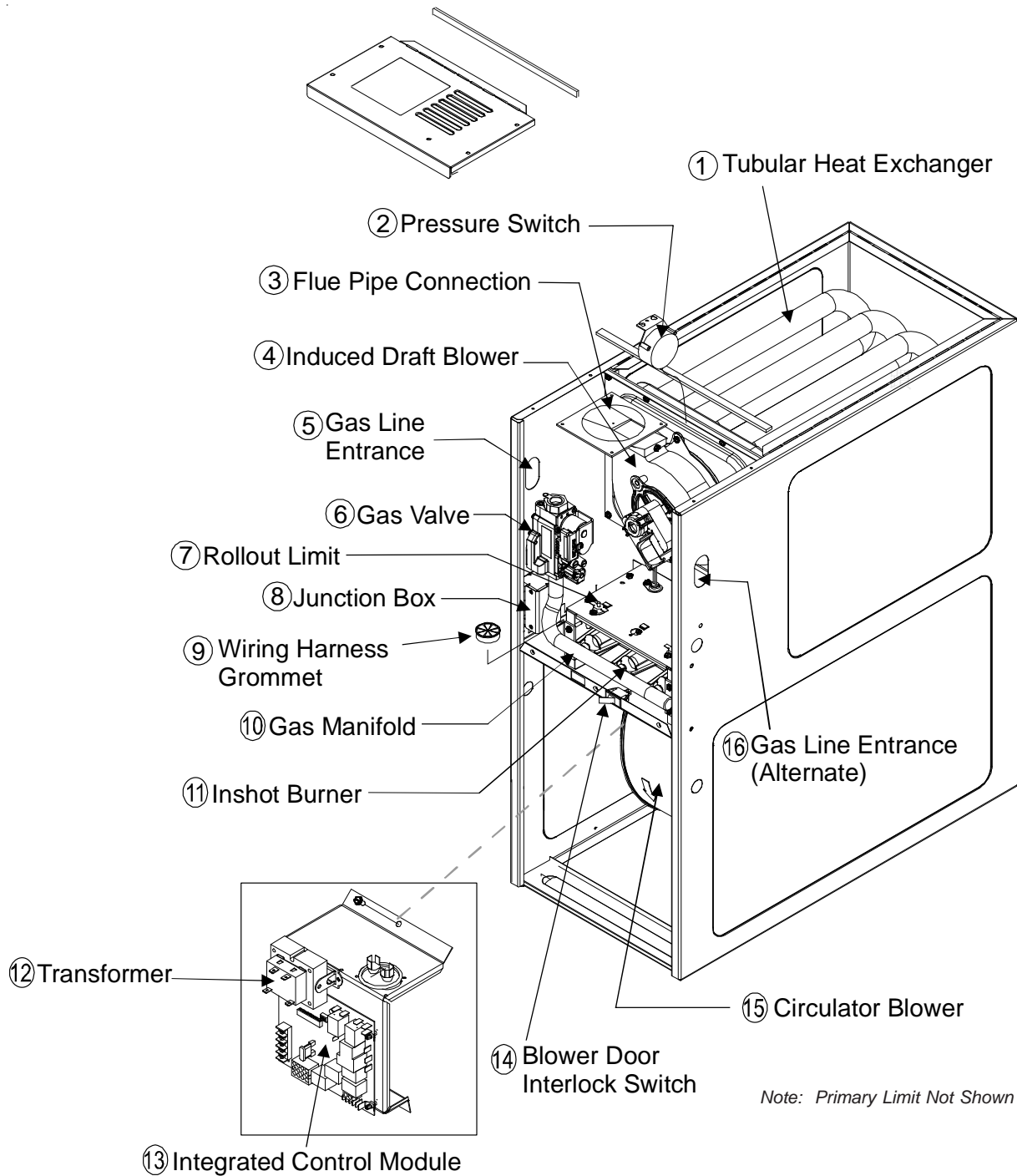

## Upflow/Horizontal

- |                          |                                  |
|--------------------------|----------------------------------|
| 1 Tubular Heat Exchanger | 9 Wiring Harness Grommet         |
| 2 Pressure Switch        | 10 Gas Manifold                  |
| 3 Flue Pipe Connection   | 11 Inshot Burner                 |
| 4 Induced Draft Blower   | 12 Transformer                   |
| 5 Gas Line Entrance      | 13 Integrated Control Module     |
| 6 Gas Valve              | 14 Blower Door Interlock Switch  |
| 7 Rollout Limit          | 15 Circulator Blower             |
| 8 Junction Box           | 16 Gas Line Entrance (Alternate) |

# PRODUCT DIMENSIONS

## GMH8

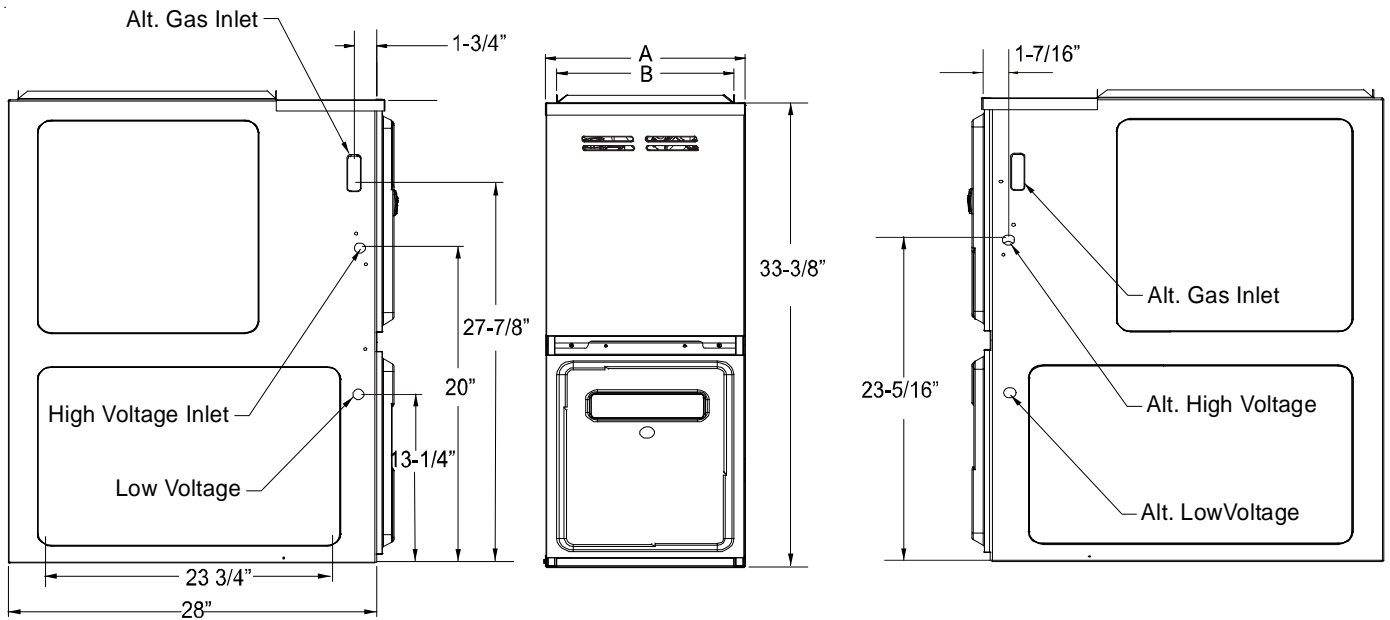

MODEL	A	B
GMH80453A*C*	14	12-1/2
GMH80703A*C*		
GMH80704B*C*		
GMH80903B*C*	17-1/2	16
GMH80904B*C*		
GMH80905C*C*	21"	19-1/2
GMH81155C*C*		
GMH81405D*C*	24-1/2	23

All dimensions are in inches.

# PRODUCT DESIGN

Pressure Switch Trip Points		
Model	Trip Point ID Blower Pressure Switch	ID Blower Pressure Switch Part #
GMH80453A*C*	-0.70	B1370158
GMH80703A*C*	-0.70	B1370158
GMH80704B*C*	-0.75	B1370179
GMH80903B*C*	-0.75	B1370179
GMH80904B*C*	-0.75	B1370179
GMH80905B*C*	-0.75	B1370179
GMH81155C*C*	-0.90	0130F00041
GMH81405D*C*	-0.80	0130F00042

For installaions in Canada, the GMH8 furnace is certified only to 4,500 ft.

\* Negative pressure readings are in inches of water column (\*w.c.)

PRIMARY LIMIT				
Part Number	0130F00035	20162906	20162903	0130F00036
Open Setting (°F)	220	170	160	180
GMH80453A*C*	1	---	---	---
GMH80703A*C*	---	1	---	---
GMH80704B*C*	---	1	1	---
GMH80903B*C*		1		
GMH80904B*C*	--	---	1	--
GMH80905B*C*	--	---	---	1
GMH81155C*C*	--	---	---	1
GMH81405D*C*	---	---	1	--

ROLLOUT LIMIT SWITCHES	
Part Number	10123529
Open Setting (°F)	300
GMH80453A*C*	2
GMH80703A*C*	2
GMH80704B*C*	2
GMH80903B*C*	2
GMH80904B*C*	2
GMH80905B*C*	2
GMH81155C*C*	2
GMH81405D*C*	2

AUXILIARY LIMIT SWITCHES	
Part Number	0130F00038
Open Setting (°F)	120
GMH80453A*C*	1
GMH80703A*C*	1
GMH80704B*C*	1
GMH80903B*C*	1
GMH80904B*C*	1
GMH80905B*C*	1
GMH81155C*C*	1
GMH81405D*C*	1

# PRODUCT DESIGN

## Coil Matches:

A large array of Goodman® brand coils are available for use with the GMH8 furnaces, in either upflow or horizontal applications. These coils are available in both cased and uncased models (with the option of a field installed TXV expansion device). These 80% furnaces match up with the existing Goodman® brand coils as shown in the chart below.

## Coil Matches (Goodman® units using R22 and R-410A):

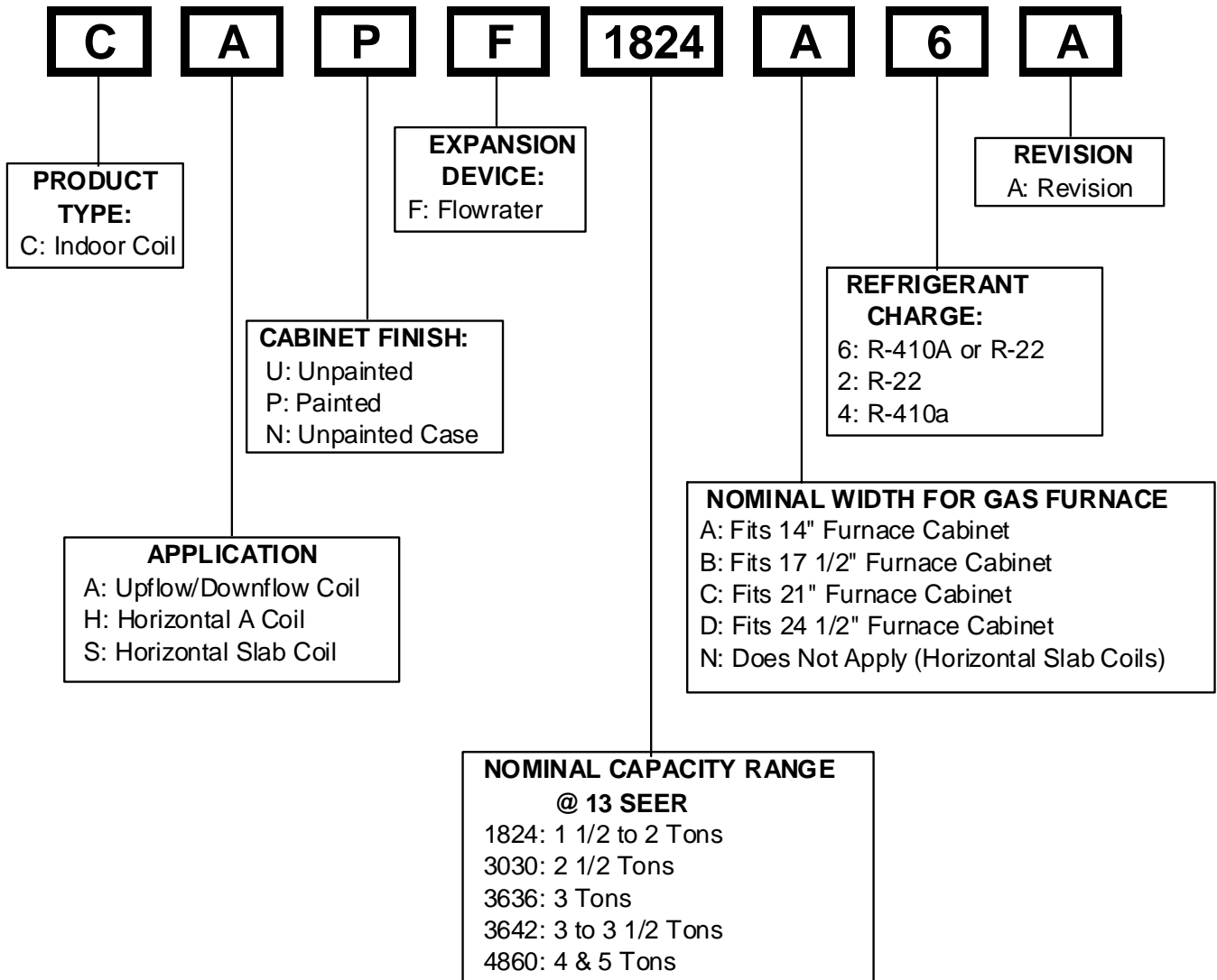

- All CAPF coils in B, C, & D widths have insulated blank off plates for use with one size smaller furnaces.
- All CAPF coils have a CAUF equivalent.
- All CHPF coils in B, C & D heights have an insulated Z bracket for use with one size smaller furnace.
- All proper coil combinations are subject to being AHRI rated with a matched outdoor unit.

# PRODUCT DESIGN

## Thermostats:

The following Amana® brand Thermostats are suggested for use with the GMH8 Furnace Models:

THERMOSTATS				
Thermostat	Mech./Digital	Programmable	Cool	Heat
CHT-18-60	Mechanical	Yes	Yes	Yes
CH70TG	Digital	No	Yes	Yes
CHSATG	Mechanical	Yes	Yes	Yes
H20TWR	Mechanical	Yes	No	Yes

## Filters:

Filters are required with this furnace and must be provided by the installer. The filters used must comply with UL900 or CAN/ULCS111 standards. Installing this furnace without filters will void the unit warranty.

### Upflow Filters

Side Return(s)		
Cabinet Width (in.)	Nominal Filter Size (in.)	Approx. Flow Area (in <sup>2</sup> )
All	16 x 25 x 1	400

Bottom Return		
Cabinet Width (in.)	Nominal Filter Size (in.)	Approx. Flow Area (in <sup>2</sup> )
14	12 x 25 x 1	300
17-1/2	14 x 25 x 1	350
21	16 x 25 x 1	400
24-1/2	20 x 25 x 1	500

Refer to Minimum Filter Area tables to determine filter area requirement. **NOTE:** Filters can also be installed elsewhere in the duct system such as a central return.

MINIMUM FILTER SIZES		
FURNACE INPUT	FILTER SIZE	TYPE
45M	160 in <sup>2</sup>	permanent
70M	241 in <sup>2</sup>	permanent
90M	320 in <sup>2</sup>	permanent
115M	400 in <sup>2</sup>	permanent
140M	370 in <sup>2</sup>	permanent
45M	320 in <sup>2</sup>	disposable
70M	483 in <sup>2</sup>	disposable
90M	640 in <sup>2</sup>	disposable
115M	800 in <sup>2</sup>	disposable
140M	738 in <sup>2</sup>	disposable

PERMANENT NOMINAL 600 F.M. FACE VELOCITY  
DISPOSABLE NOMINAL 300 F.M. FACE VELOCITY

# PRODUCT DESIGN

## Dual \$aver Configuration & Operation

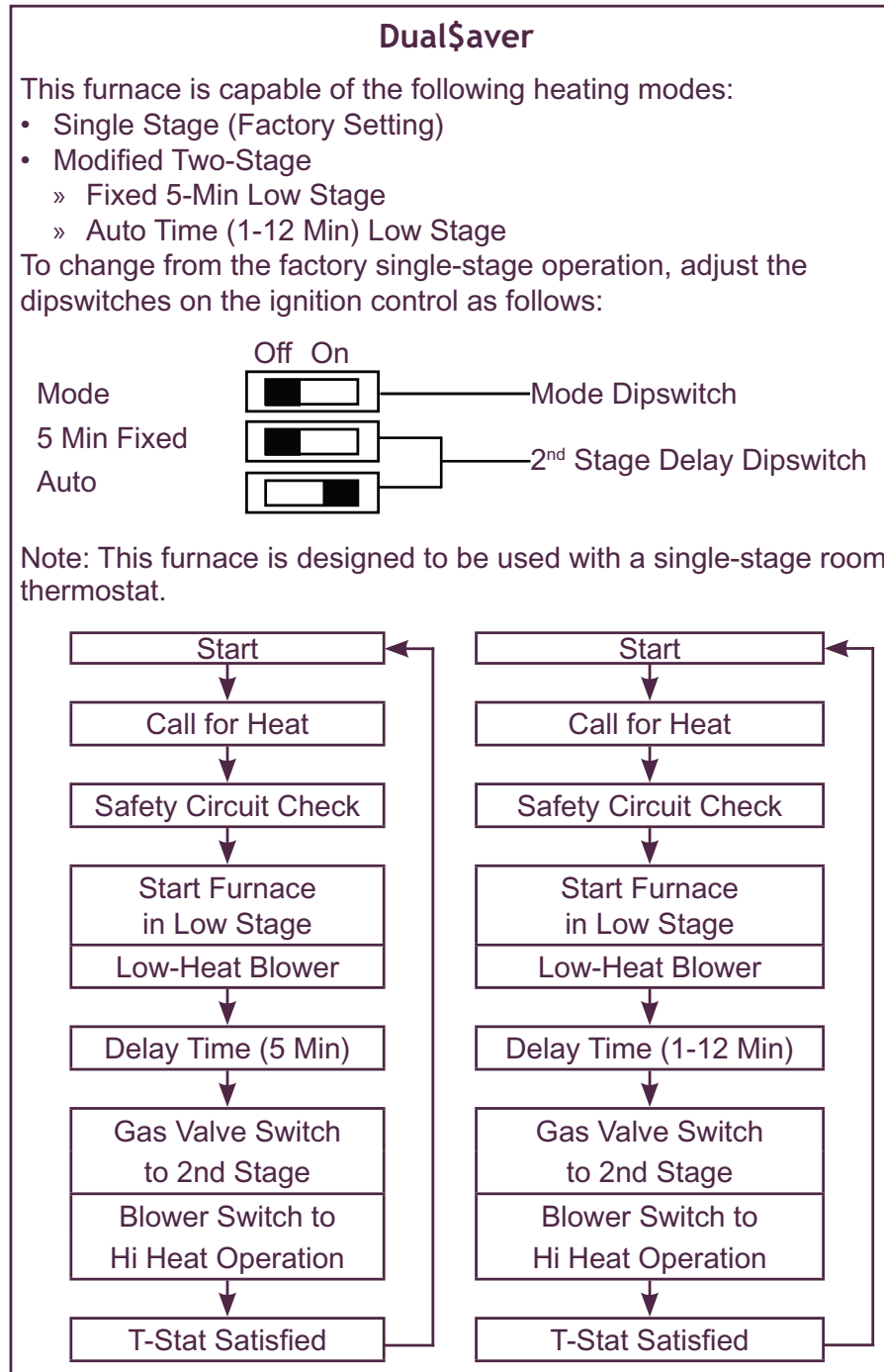

# FURNACE SPECIFICATIONS

MODEL	GMH80453A°C*	GMH80703A°C*	GMH80704B°C*	GMH80903B°C*	GMH80904B°C*	GMH80905C°C*	GMH81155C°C*	GMH81405D°C*
Input, Natural Gas (BTUH)	45,000	70,000	70,000	90,000	90,000	90,000	115,000	140,000
Output, Natural Gas (BTUH) <sup>1</sup>	36,000	56,000	56,000	72,000	72,000	72,000	92,000	112,000
Output, LP (BTUH)	32,000	48,000	48,000	64,000	64,000	64,000	80,000	96,000
A.F.U.E.	80.0%	80.0%	80.0%	80.0%	80.0%	80.0%	80.0%	80.0%
Rated External Static (" w.c.)	0.20 - 0.50	0.20 - 0.50	0.20 - 0.50	0.20 - 0.50	0.20 - 0.50	0.20 - 0.50	0.20 - 0.50	0.20 - 0.50
Temperature Rise (°F)	25 - 55	25 - 55	20 - 50	35 - 65	35 - 65	35 - 65	35 - 65	40 - 70
Pressure Switch Trip Point (" w.c.)	-0.70	-0.70	-0.75	-0.75	-0.75	-0.75	-0.90	-0.80
Blower Wheel (D" x W")	10x6	10x6	10x8	10x8	10x8	10x8	10x8	11x10
Blower Horsepower	1/3	1/3	1/2	1/3	1/2	1/2	1/2	3/4
Blower Speeds	4	4	4	4	4	4	4	4
Max CFM @ 0.5 E.S.P.	1280	1100	1610	1439	1738	1854	1902	2084
Power Supply (Volts/Hz/Ph)	115/60/1	115/60/1	115/60/1	115/60/1	115/60/1	115/60/1	115/60/1	115/60/1
Minimum Circuit Ampacity (MCA) <sup>2</sup>	8.1	8.1	12.5	8.1	12.5	12.5	12.5	14.7
Maximum Overcurrent Device <sup>3</sup>	15	15	15	15	15	15	15	15
Transformer (VA)	40	40	40	40	40	40	40	40
Primary Limit Setting (°F)	220°	170°	170°	170°	160°	180°	180°	160°
Auxiliary Limit Setting (°F)	120°	120°	120°	120°	120°	120°	120°	120°
Rollout Limit Setting (°F)	300°	300°	300°	300°	300°	300°	300°	300°
Fan Delay On Heating	30	30	30	30	30	30	30	30
Off Heating *	150	150	150	150	150	150	150	150
Fan Delay On Cooling	5	5	5	5	5	5	5	5
Off Cooling	45	45	45	45	45	45	45	45
Fan Delay On - Fan Only	0	0	0	0	0	0	0	0
Gas Supply Pressure (Natural/Propane) (" w.c.)	7 / 11	7 / 11	7 / 11	7 / 11	7 / 11	7 / 11	7 / 11	7 / 11
Manifold Pressure (Natural/Propane) (" w.c.)	3.5 / 10	3.5 / 10	3.5 / 10	3.5 / 10	3.5 / 10	3.5 / 10	3.5 / 10	3.5 / 10
Orifice Size (Natural/Propane)	43 / 55	43 / 55	43 / 55	43 / 55	43 / 55	43 / 55	43 / 55	43 / 55
Number of Burners	2	3	3	4	4	4	5	6
Vent Connector Diameter (inches)	4	4	4	4	4	4	4	4
Shipping Weight (lbs.)	115	125	136	146	146	154	154	153

\*Off Heating - This fan delay timing is adjustable (90, 120, 150 or 180 seconds). 150 seconds as shipped.

1. These furnaces are manufactured for natural gas operation. Optional kits are available for conversion to propane operation.
2. Minimum Circuit Ampacity calculated as: (1.25 x Circulator Blower Amps) + I.D. Blower Amps. Wire sizes should be determined in accordance with National Electrical Codes. Extensive wire runs will require larger wire sizes.
3. Maximum Overcurrent protections Device refers to maximum recommended fuse or circuit breaker size. May use time delay fuses or HACR-type circuit breakers of the same sizes as noted.

## NOTES:

1. For elevations above 2000 feet the rating should be reduced by 4% for each 1000 feet above sea level. The furnace must not be derated, orifice changes should only be made if necessary for altitude.
2. The total heat loss from the structure as expressed in TOTAL BTU/HR must be calculated by the manufacturers method or in accordance with the "A.S.H.R.A.E. GUIDE" or "MANUAL J-LOAD CALCULATIONS" published by the AIR CONDITIONING CONTRACTORS OF AMERICA. The total heat loss calculated should be equal to or less than the heating capacity. Output based on D.O.E. test procedures, steady state efficiency times output.

# BLOWER PERFORMANCE SPECIFICATIONS

(CFM & Temperature Rise vs. External Static Pressure)															
Model ( Heating Speed As Shipped )	Motor Speed	Tons AC at 0.5" ESP	EXTERNAL STATIC PRESSURE (Inches Water Column)												
			0.1		0.2		0.3		0.4		0.5		0.6	0.7	0.8
			CFM	RISE	CFM	RISE	CFM	RISE	CFM	RISE	CFM	RISE	CFM	CFM	CFM
*M(H/S)80453A*** (MEDIUM)	HIGH	3.0	1521	22	1466	23	1414	24	1373	24	1298	26	1243	1164	1075
	MED	2.5	1160	29	1160	29	1132	29	1121	30	1082	31	1042	997	925
	MED-LO	2.0	961	35	955	35	948	35	932	36	913	37	882	821	803
	LOW	1.5	781	43	785	42	781	43	773	43	761	44	745	716	668
*M(H/S)80703A*** (MEDIUM)	HIGH	3.0	1422	36	1352	38	1307	40	1197	43	1157	45	1092	1075	983
	MED	2.5	1098	47	1081	48	1051	49	1039	50	1021	51	983	924	868
	MED-LO	2.0	919	56	913	57	892	58	847	---	829	---	818	792	728
	LOW	1.5	758	---	741	---	741	---	733	---	699	---	677	649	626
*M(H/S)80704B*** (MEDIUM)	HIGH	4.0	2134	---	2100	25	2042	25	1975	26	1883	28	1786	1700	1601
	MED	3.5	1668	31	1663	31	1656	31	1645	32	1616	32	1549	1492	1391
	MED-LO	3.0	1419	37	1426	36	1426	36	1432	36	1419	37	1378	1328	1261
	LOW	2.5	1134	46	1145	45	1166	44	1171	44	1160	45	1144	1111	1071
*M(H/S)80903B*** (MEDIUM)	HIGH	3.0	1607	41	1572	42	1547	43	1498	45	1448	46	1390	1302	1222
	MED	2.5	1159	58	1156	58	1145	58	1127	59	1108	60	1075	1033	957
	MED-LO	2.0	938	---	916	---	916	---	900	---	889	---	865	829	785
	LOW	1.5	785	---	766	---	743	---	730	---	709	---	683	666	604
*M(H/S)80904B*** (MEDIUM)	HIGH	4.0	2051	---	1983	---	1895	35	1812	37	1725	39	1627	1530	1439
	MED	3.5	1736	38	1708	39	1652	40	1611	41	1540	43	1475	1394	1307
	MED-LO	3.0	1493	45	1668	40	1459	46	1429	47	1389	48	1339	1274	1204
	LOW	2.5	1200	56	1185	56	1180	56	1173	57	1158	58	1125	1125	1080
*M(H/S)80905C*** (MEDIUM)	HIGH	5.0	2290	---	2229	---	2155	---	2047	---	1960	---	1837	1712	1584
	MED	4.0	1852	36	1820	37	1777	38	1719	39	1641	41	1567	1469	1382
	MED-LO	3.5	1615	41	1592	42	1556	43	1516	44	1470	45	1405	1346	1235
	LOW	3.0	1290	52	1285	52	1265	53	1235	54	1214	55	1174	1044	904
*M(H/S)81155C*** (MEDIUM)	HIGH	5.0	2323	37	2225	38	2120	40	2040	42	1974	43	1801	1688	1577
	MED	4.0	1858	46	1847	46	1799	47	1744	49	1674	51	1577	1493	1399
	MED-LO	3.5	1596	53	1587	54	1571	54	1552	55	1493	57	1397	1326	1217
	LOW	3.0	1291	---	1272	---	1261	---	1257	---	1205	---	1168	1118	1060
*M(H/S)81405D*** (MEDIUM)	HIGH	5.0	2469	42	2389	43	2300	45	2223	47	2131	49	2027	1902	1786
	MED	4.0	1575	66	1558	67	1545	67	1513	69	1500	69	1419	1354	1271
	MED-LO	3.5	1402	---	1380	---	1343	---	1319	---	1296	---	1245	1183	1106
	LOW	3.0	1200	---	1186	---	1161	---	1127	---	1082	---	1042	995	926

1. CFM in chart is without filters(s). Filters do not ship with this furnace, but must be provided by the installer.
2. All furnaces ship as high speed cooling. Installer must adjust blower cooling speed as needed.
3. For most jobs, about 400 CFM per ton when cooling is desirable.
4. INSTALLATION IS TO BE ADJUSTED TO OBTAIN TEMPERATURE RISE WITHIN THE RANGE SPECIFIED ON THE RATING PLATE.
5. The chart is for information only. For satisfactory operation, external static pressure must not exceed value shown on rating plate. The shaded area indicates ranges in excess of maximum external static pressure allowed when heating. The data for 0.6" w.c. to 0.8" w.c. is shown for air conditioning purposes only.
6. The dashed (---) areas indicate a temperature rise not recommended for this model.
7. The above chart is for U.S. furnaces installed at 0-4000 feet. At higher altitudes, a properly derated unit will have approximately the same temperature rise at a particular CFM, while the ESP at that CFM will be lower.

# BLOWER PERFORMANCE SPECIFICATIONS

BTU OUTPUT vs TEMPERATURE RISE CHART

