

AR SERIES COMMERCIAL AIR HANDLERS INSTALLATION & OPERATING INSTRUCTIONS

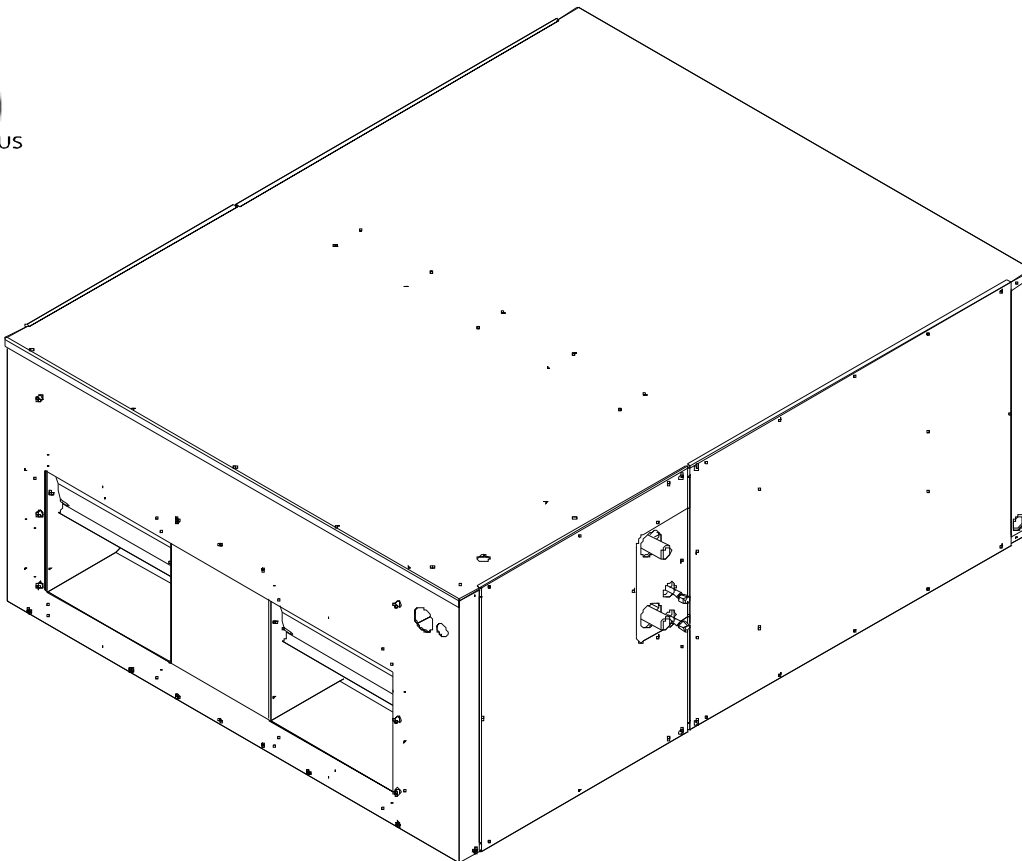

**NOTE: AR models are suitable for Upflow and Horizontal Installations only.
Do not use for Downflow Installations**



RECOGNIZE THIS SYMBOL AS A SAFETY PRECAUTION.

ATTENTION INSTALLING PERSONNEL

Prior to installation, thoroughly familiarize yourself with this Installation Manual. Observe all safety warnings.
During installation or repair, caution is to be observed.
It is your responsibility to install the product safely and to educate the customer on its safe use.



CONTENTS

Important Safety Instructions	2
Product Identification	3
Unit Inspection	3
Codes and Regulations	3
Replacement Parts	4
Pre-Installation Instructions	4
Location	4
Ductwork	4
Electric Heat	4
Electrical Supply Wire and MOP	5
Conversion of 460 Electrical Power Supply	7
Electrical Connections	8
Heat Kit Installation	9
Refrigerant Lines	9
Evaporator Coil TXV	10
Airflow	10
Belt Tension	11
Regular Maintenance	11
Wiring Diagram	12

Important Safety Instructions

The following symbols and labels are used throughout this manual to indicate immediate or potential safety hazards. It is the owner's and installer's responsibility to read and comply with all safety information and instructions accompanying these symbols. Failure to heed safety information increases the risk of personal injury, property damage, and/or product damage.

WARNING

HIGH VOLTAGE!
Disconnect ALL power before servicing.
Multiple power sources may be present.
Failure to do so may cause property damage,
personal injury or death.



WARNING

Installation and repair of this unit should be performed **ONLY** by individuals meeting (at a minimum) the requirements of an "entry level technician" as specified by the Air-Conditioning, Heating and Refrigeration Institute (AHRI). Attempting to install or repair this unit without such background may result in product damage, personal injury or death.

WARNING

This product is factory-shipped for use with 208-230/3/60 electrical power supply. However, the airhandler can be reconfigured to operate with a 460/3/60 power supply, provided the conversion noted in section "Conversion to 460 Electrical Supply" section of this manual is performed.

WARNING

To avoid property damage, personal injury or death due to electrical shock, this unit **MUST** have an uninterrupted, unbroken electrical ground. The electrical ground circuit may consist of an appropriately sized electrical wire connecting the ground lug in the unit control box to the building electrical service panel.

Other methods of grounding are permitted if performed in accordance with the National Electric Code (NEC)/American National Standards Institute (ANSI)/National Fire Protection Association (NFPA) 70 and local/state codes. In Canada, electrical grounding is to be in accordance with the Canadian Electric Code (CSA) C22.1.

WARNING

This airhandler is designed for Upflow or Horizontal-Left applications. **DO NOT INSTALL IN THE DOWNFLOW OR HORIZONTAL-RIGHT ORIENTATION.**

CAUTION

When installing or servicing this equipment, safety clothing, including hand and eye protection, is strongly recommended. If installing in an area that has special safety requirements (hard hats, etc.), observe these requirements.

WARNING

Do not connect to or use any device that is not design-certified by Goodman for use with this unit. Serious property damage, personal injury, reduced unit performance and/or hazardous conditions may result from the use of such non-approved devices.

WARNING

To prevent the risk of property damage, personal injury, or death, do not store combustible materials or use gasoline or other flammable liquids or vapors in the vicinity of this unit.

⚠ DANGER PELIGRO



CARBON MONOXIDE POISONING HAZARD

Special Warning for Installation of Furnace or Air Handling Units in Enclosed Areas such as Garages, Utility Rooms or Parking Areas

Carbon monoxide producing devices (such as an automobile, space heater, gas water heater, etc.) should not be operated in enclosed areas such as unventilated garages, utility rooms or parking areas because of the danger of carbon monoxide (CO) poisoning resulting from the exhaust emissions. If a furnace or air handler is installed in an enclosed area such as a garage, utility room or parking area and a carbon monoxide producing device is operated therein, there must be adequate, direct outside ventilation.

This ventilation is necessary to avoid the danger of CO poisoning which can occur if a carbon monoxide producing device continues to operate in the enclosed area. Carbon monoxide emissions can be (re)circulated throughout the structure if the furnace or air handler is operating in any mode.

CO can cause serious illness including permanent brain damage or death.

B10259-216

	AR0904	AR1204
Net Weight (Lbs.)	375	400
Shipping Weight (Lbs.)	405	430
Refrigerant	R-410A	R-410A
Blower Wheel (Dia x Width)	11X10	11X10
Blower Wheel Quantity	2	2
Motor Type	Belt Drive	Belt Drive
Motor Qty	1	1
Motor (HP)	1 1/2	2
Motor (RPM)	1750	1750
Motor Sheave Type	Adjustable Variable Pitch	
Motor Sheave Diameter (in)	1.9" - 2.9"	2.8" - 3.8"
Blower Wheel Pulley Type	Fixed Diameter	
Blower Wheel Pulley Dia (in)	5.9	5.9
Evaporator Coil Material	Copper Tubes / Al Fins	
Face Area (Ft ²)	8.9	10.0
Number of Rows	4	4
Suction Line Quantity	1	2
Suction Line Connection (in) *	1 1/8	1 1/8
Liquid Line Quantity	1	2
Liquid Line Connection (in)*	5/8	3/8
Metering Device	Thermal Expansion Valve (TXV)	
TXV Type	Adjustable	
TXV Quantity	1	2

*Note: Consult with the condenser specifications for suction and liquid line sizing.

Product Identification

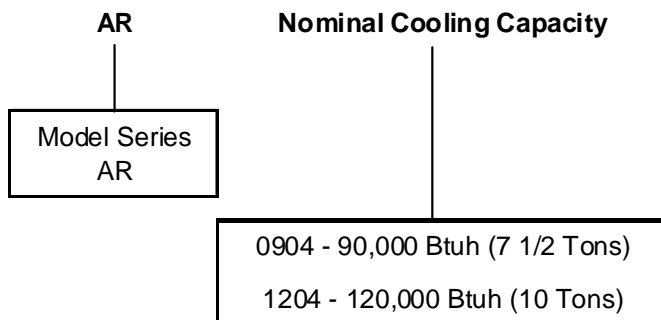

Product Description

When matched with GSX11 and GSZ11 condenser this system complies with the minimum efficiency requirements found in ASHRAE 90.1-2007. See the Goodman GSX11 and GSZ11 specification sheets for details on these condensers. For other Goodman condenser(s) that can be matched with this airhandler to obtain ASHRAE 90.1-2007 compliance, consult with your local distributor.

The AR series is intended for use with a room thermostat. This thermostat is not supplied with this equipment. Only thermostats that use 24 VAC control circuitry are to be used.

Unit Inspection

Upon delivery, the unit is to be inspected for damage. Any damage must be reported immediately to the carrier. Do not install this equipment if it is determined that the integrity or safety has been compromised by freight damage.

Using the table "Model Identification" section check the equipment model number to ensure the unit is appropriately sized for the condenser unit(s).

If an incorrect unit is supplied it must not be installed and it is to be returned to the supplier. The manufacturer assumes no responsibility for the installation of incorrect delivered units.

The evaporator coil contains a high-pressure inert gas holding charge.

Codes & Regulations

This product is designed and manufactured to comply with national codes. Installation in accordance with such codes and/or prevailing local codes/regulations is the responsibility of the installer. The manufacturer assumes no responsibility for equipment installed in violation of any codes or regulations.

The United States Environmental Protection Agency (EPA) has issued various regulations regarding the introduction and disposal of refrigerants. Failure to follow these regulations may harm the environment and can lead to the imposition of substantial fines. Should you have any questions please contact the local office of the EPA.

Replacement Parts

When reporting shortages or damages, or ordering repair parts, give the complete product model and serial numbers as stamped on the product. Replacement parts for this product are available through your contractor or local distributor. For the location of your nearest distributor consult the white business pages, the yellow page section of the local telephone book or contact:

CONSUMER AFFAIRS DEPARTMENT
GOODMAN MANUFACTURING COMPANY, L.P.
7401 SECURITY WAY
HOUSTON, TEXAS 77040
877-254-4729

If replacing an air handler, the system must be manufacturer approved and Air-Conditioning, Heating, and Refrigeration Institute (AHRI) matched. **NOTE:** Installation of unmatched systems is strongly discouraged.

Pre-Installation Instructions

Carefully read all instructions for the installation prior to installing product. Make sure each step or procedure is understood and any special considerations are taken into account before starting installation. Assemble all tools, hardware and supplies needed to complete the installation. Some items may need to be purchased locally. Make sure everything needed to install the product is on hand before starting.

Location

NOTE: Airhandlers are designed for *indoor installation only*.

When installing this airhandler in an enclosed area, such as a garage/parking area, as with any carbon monoxide producing device (i.e. and automobile, space heater, water heater, etc.), insure that the area is properly ventilated.

The AR airhandler is suitable for installation in multiple locations including:

- * Overhead (attic/mezzanine, etc.)
- * Closet/mechanical room

When installing this airhandler, consideration is to be given to minimize the length of refrigerant tubing. Also, do not install the airhandler in a location either above or below the condenser that violates the instructions provided with the condenser.

The clearance from a combustible surface to the unit may be 0". However, service clearance is to take precedence. In addition allow a minimum of 36" in front of the unit for service clearance. Allow sufficient clearance to remove the heater elements for service or replacement in heat kits when utilized in application.

When installing in an area directly over a finished ceiling (such as an attic), an emergency drain pan is required directly under the unit. See local and state codes for additional requirements.

When installing this unit in an area that may become wet, elevate the unit with a sturdy, non-porous material.

In installations that may lead to physical damage (warehouse, industrial sites, etc.), it is advised to install a protective barrier to prevent such damage.

Ductwork

This AR air handler is designed for a complete supply and return ductwork system.



CAUTION

Do not operate this product without all the ductwork attached.

To ensure correct system performance, the ductwork is to be sized to accommodate 375-425 CFM per ton of cooling with the static pressure not to exceed .5" WC. Inadequate ductwork that restricts airflow can result in improper performance and compressor or heater failure. Ductwork is to be constructed in a manner that limits restrictions and maintains suitable air velocity. Ductwork is to be sealed to the unit in a manner that will prevent leakage.

Supply Ductwork and Flanges

The supply ductwork flanges are shipped loose and required to be field installed. See the following sketch for further details: Dimensions are approximately 40" x 13-1/8".

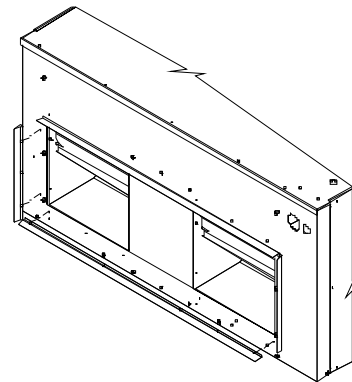

Return Ductwork

DO NOT TERMINATE THE RETURN DUCTWORK IN AN AREA THAT CAN INTRODUCE TOXIC, OR OBJECTIONABLE FUMES/ODORS INTO THE DUCTWORK. The return ductwork is to be introduced into the air handler bottom (upflow configuration). The cabinet dimensions are 48" x 24".

Return Air Filters

Each installation must include a return air filter. This unit is factory equipped with disposable return air filters. To ensure optimum performance, frequent filter replacement is advised. See the following table for the factory installed filter sizes.

Model	Filter Size (in)	Qty.
AR0904	16 x 20 x 2	4
AR1204	16 x 20 x 2	2
	20 x 20 x 2	2

Electric Heat

Refer to this manual in combination with the instructions provided with the heat kit for the correct installation procedure.

The electrical characteristics of the airhandler, the electric heat kit, and the building power supply must agree.

The air handlers listed in this manual do not have factory installed electric heat. Electric heat is available as an accessory. If installing this option, the **ONLY** heat kits that can be used are the AHKD series.

AHKD MODEL NUMBER	NOMINAL KW	ELECTRICAL CHARACTERISTICS	STAGES
AHKD15-3	15	208-230/3/60	1
AHKD15-4	15	460/3/60	1
AHKD20-3	20	208-230/3/60	2
AHKD20-4	20	460/3/60	2
AHKD30-3	30	208-230/3/60	2
AHKD30-4	30	460/3/60	2

For all supply voltages, use the correction factors in the following tables, multiplied by KW and (or) temperature rise to have corrected results.

KW Correction Factors (-3 Models)

Supply Voltage	240	230	220	210	208
Correction Factor	1	0.92	0.84	0.77	0.75

KW Correction Factors (-4 Models)

Supply Voltage	480	460	440	415	380
Correction Factor	1	0.92	0.84	0.75	0.63

The heating mode temperatures rise is dependent upon the system airflow, the supply voltage, and the heat kit size (KW) selected. Use the following table to determine the temperature rise (°F).

AR0904 Temperature Rise Table (Degrees F)

Airhandler	Heat Kit	Supply Voltage			
	KW	CFM	208	240	480
AR0904	15	2800	14	19	19
		2900	14	18	18
		3000	13	18	18
		3100	13	17	17
		3200	12	17	17
	20	2800	19	25	25
		2900	18	24	24
		3000	18	24	24
		3100	17	23	23
		3200	17	22	22
	30	2800	28	38	38
		2900	27	37	37
		3000	27	35	35
		3100	26	34	34
		3200	25	33	33

AR1204 Temperature Rise Table (Degrees F)

Airhandler	Heat Kit	Supply Voltage			
	KW	CFM	208	240	480
AR1204	15	3800	10	14	14
		3900	10	14	14
		4000	10	13	13
		4100	10	13	13
		4200	9	13	13
	20	3800	14	19	19
		3900	14	18	18
		4000	13	18	18
		4100	13	17	17
		4200	13	17	17
	30	3800	21	28	28
		3900	20	27	27
		4000	20	27	27
		4100	19	26	26
		4200	19	25	25

NOTE: The preceding table is calculated with both stages of electric heat engaged (2 stage heat systems). For systems using staged electric heat, divide the temperature rise from the table by 2 for 1st stage operation.

Electrical Supply Wire and MOP

CAUTION

FIRE HAZARD!
To avoid the risk of property damage, personal injury or fire, use only copper conductors.

WARNING

HIGH VOLTAGE!
Disconnect ALL power before servicing. Multiple power sources may be present. Failure to do so may cause property damage, personal injury or death.



WARNING

HIGH VOLTAGE!
To avoid property damage, personal injury or death due to electrical shock, this unit **MUST** have an **uninterrupted, unbroken electrical ground**. The electrical ground circuit may consist of an appropriately sized electrical wire connecting the ground lug in the unit control box to the building electrical service panel. Other methods of grounding are permitted if performed in accordance with the National Electric Code (NEC)/American National Standards Institute (ANSI)/National Fire Protection Association (NFPA) 70 and local/state codes. In Canada, electrical grounding is to be in accordance with the Canadian Electric Code (CSA) C22.1.

Building Electrical Service Inspection

This unit is designed for 3-phase operation. DO NOT OPERATE ON A SINGLE PHASE POWER SUPPLY. SEE THE PRECEDING WARNING. Measure the power supply to the unit. The supply voltage **must** be in agreement with the unit nameplate power requirements and within the range shown below:

Nominal	Minimum Supply Voltage	Maximum Supply Voltage
208 - 230	187	253
460	414	506

Voltage Balance The supply voltage shall be unbalance (phase to phase) within 2%. To calculate the percentage of voltage unbalance use the following formula:

Percentage Max Voltage Deviation From Average Voltage Unbalance = $100 \times \frac{\text{Max Voltage Deviation From Average Voltage}}{\text{Average Voltage}}$
Example

$$\begin{aligned} L1 - L2 &= 220 \text{ V} \\ L2 - L3 &= 216 \text{ V} \\ L1 - L3 &= 213 \text{ V} \end{aligned}$$

$$\begin{aligned} \text{Avg. Voltage} &= (220+216+213) / 3 \\ &= 649 / 3 \\ &= 216 \end{aligned}$$

$$\text{Max. Deviation from Avg.} = 220 - 216 = 4$$

$$\begin{aligned} \% \text{ Voltage Unbalance} &= 100 \times (4 / 216) \\ &= 400 / 216 \\ &= 1.8\% \end{aligned}$$

Determine Wire Size The selection of the appropriate supply wire size is important to the operation of the equipment. When selecting the wire size the following are important elements of the decision:

- The wire size is adequately sized to carry the Minimum Circuit Ampacity (MCA). Refer to the NEC (USA) or CSA (Canada) for wire sizing. The unit MCA for the airhandler and the optional electric heat kit can be found on the equipment S&R plate and the following table.

AIRHANDLER	VOLTAGE	HEAT KIT	MCA
AR0904	208-230	None	6.5
		AHKD15-3	49.8
		AHKD20-3	64.2
	460	None	3.3
		AHKD15-4	24.9
		AHKD20-4	32.1
AR1204	208-230	None	9.8
		AHKD15-3	53.1
		AHKD20-3	67.5
	460	AHKD30-3	96.4
		None	4.9
		AHKD15-4	26.5
	AHKD20-4	33.7	
	AHKD30-4	48.2	

Wire Sizing

Wire size is important to the operation of your equipment. Use the following check list when selecting the appropriate wire size for your unit.

- Wire size must carry the Minimum Circuit Ampacity (MCA).
- Refer to the NEC (USA) or CSA (Canada) for wire sizing. The unit MCA for the air handler and the optional electric heat kit can be found on the unit Series and Rating Plate.
- Wire size allows for no more than a 2% voltage drop from the building breaker/fuse panel to the unit.

Refer to the latest edition of the National Electric Code or in Canada the Canadian Electric Code when determining the correct wire size. The following table shows the current carrying capabilities for copper conductors rated at 75°C with a 2% voltage drop. Use **Table 6** to determine the voltage drop per foot of various conductors.

MAXIMUM ALLOWABLE LENGTH IN FEET
TO LIMIT VOLTAGE DROP TO 2%

Wire Size (AWG)	Minimum Circuit Ampacity (MCA)							
	10	15	20	25	30	35	40	45
14	75	50	37	NR	NR	NR	NR	NR
12	118	79	59	47	NR	NR	NR	NR
10	188	125	95	75	63	54	NR	NR
8	301	201	150	120	100	86	75	68
6	471	314	235	188	157	134	118	110

Based on NEC 1996

Maximum Overcurrent Protection (MOP)

Every installation must include an NEC (USA) or CEC (Canada) approved overcurrent protection device. Also, check with local or state codes for any special regional requirements.

Protection can be in the form of fusing or HACR style circuit breakers. The Series and Rating Plate can be used as a guide for selecting the MAXIMUM overcurrent device or reference the following table.

NOTE: Fuses or circuit breakers are to be sized larger than the equipment MCA but not to exceed the MOP.

AIRHANDLER	HEAT KIT	MOP
AR0904	None	15
	AHKD15-3	50
	AHKD20-3	70
	AHKD30-3	100
	None	15
	AHKD15-4	25
	AHKD20-4	35
AR1204	AHKD30-4	50
	None	15
	AHKD15-3	60
	AHKD20-3	70
	AHKD30-3	100
	None	15
	AHKD15-4	30
AHKD20-4	35	
AHKD30-4	50	

Conversion Of 460 Electrical Power Supply

⚠ WARNING

THIS PRODUCT IS CAPABLE OF USING EITHER 208-230/3/60 OR 460/3/60 SUPPLY VOLTAGE. THE AIRHANDLER IS FACTORY SHIPPED FOR USE WITH 208-230/3/60 VOLTAGE. INSTALLATIONS USING 460/3/60 REQUIRE A MODIFICATION TO THE MOTOR AND TRANSFORMER ELECTRICAL CIRCUIT. DO NOT OPERATE THIS APPLIANCE USING A 460V POWER SUPPLY UNLESS THIS MODIFICATION HAS BEEN MADE. FAILURE TO OBSERVE THIS WARNING MAY RESULT IN PERSONAL INJURY, EQUIPMENT DAMAGE, AND FIRE.

IT IS ADVISABLE TO PERFORM THIS CONVERSION IN AN AREA THAT WILL PERMIT EASY ACCESSIBILITY.

Transformer. The transformer is a multi rated transformer 208V, 240V, or 480V primary input. To change from the factory setting of 230 to 460V applications remove the Orange colored wire attached to the 240 terminal on the primary side of the transformer. Install this wire on the transformer terminal marked 480. Similarly, move the Orange wire from 240 to 208 for 208V applications.

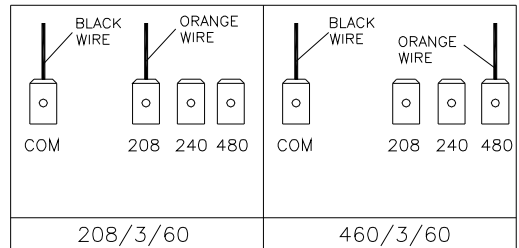

Motor Conversion This conversion requires access to the motor electrical junction box that is located on the motor endplate on the side opposite from the shaft. Use the following diagrams when performing this procedure.

AR0904 Motor

A.O. SMITH 1 1/2 HP
CONVERSION TO 460V-480V

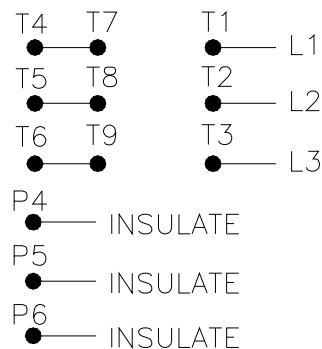

AR1204 Motor

A.O. SMITH 2 HP
CONVERSION TO 460V-480V

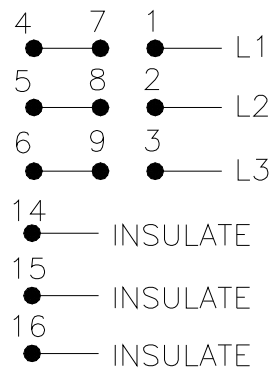

Electrical Connections

Supply Voltage

USE COPPER CONDUCTORS ONLY.

A single point supply voltage termination is provided in the airhandler control box (non-heat kit models) or heat kit control box (heat kit models). This termination is common to both the airhandler, and if equipped, heat kit. The wire is to be sized in accordance with the "Electrical Wire and MOP" section of this manual.

Air Handler Only (Non-Heat Kit Models)

Supply wire is to be routed through conduit from the service disconnect box to the unit. The airhandler is equipped with a knockout suitable for 3/4" conduit. The following diagram illustrates the supply voltage hook-up.

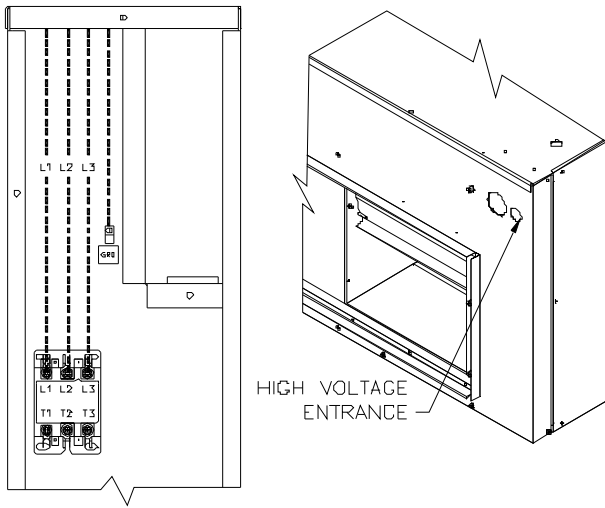

Heater Kit Models

When a heater kit is used the system uses a single point wiring hook-up. The supply wire is to be routed through conduit from the service disconnect box to the heater kit. The heat kit is equipped with a knockout suitable for 1/2" or 3/4" conduit dependent on the KW. The supply voltage is to be installed on the terminal block located in the heater kit control box.

The heater kit is factory equipped with the supply and low voltage wires for the airhandler. The low voltage connection from the heater kit is provided through a multi-pin plug which connects to a mating plug in the airhandler. The high voltage connections are to be made at the air handler contactor. These wires are to be routed through the pipe nipples supplied with the heater kit as shown in the following illustration:

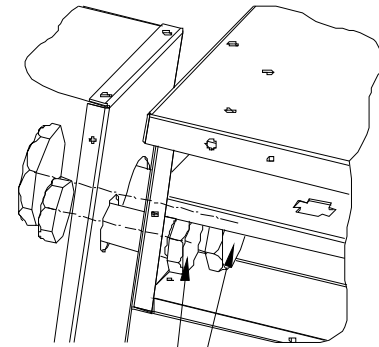

HIGH VOLTAGE WIRES LOW VOLTAGE WIRES

Low Voltage Connections

The 24V-control voltage connects the airhandler to the room thermostat and condenser. For systems using staged electric heat, the thermostat is to have W1 and W2 functions. Low voltage wiring is to be copper conductors, and be a minimum of 18AWG. A provision on the cabinet side to accept the low voltage wiring is provided. See the following drawings for typical low voltage connections.

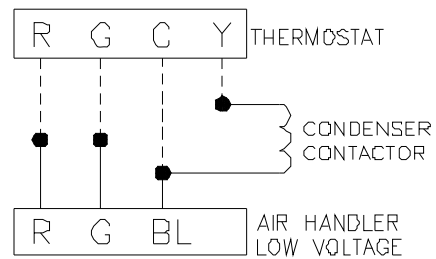

No Heat - Single Stage Cooling where R... Red, G... Green, BL.... Blue Note white wire and brown wire are not used and are to be taped.

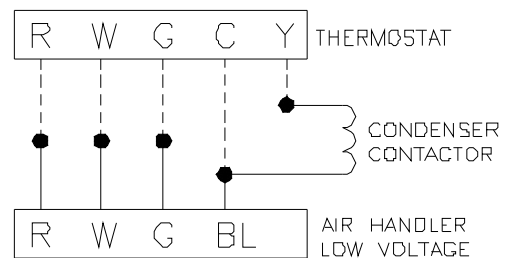

Single Stage Heat - Single Stage Cooling where R... Red, W... White, G... Green, BL.... Blue Note brown wire is not used and is to be taped.

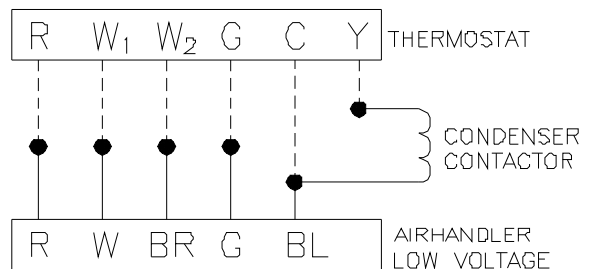

Two Stage Heat – Single Stage Cooling - where R... Red, W... White, BR... Brown, G... Green, BL.... Blue

Heat Kit Installation

Inspect for Shipping Damage. The heat kit is an optional accessory that is shipped separately from the air handler. Inspect the heat kit for damage and report any damage to the carrier and/or distributor. Do not install this accessory if it is determined that the integrity or safety has been compromised by freight damage.

Check the Nameplate. From the heat kit nameplate check the following:

- The model number agrees with the approved models (see the “Electric Heat” section of this manual).
- The correct size (kW)
- Electric characteristics, voltage and phase, agree with the building electrical supply.

Attaching the Heat Kit The heat kit attaches directly to the top panel (when viewed in the upflow position) of the airhandler. Do not screw the heat kit into the duct flanges. See the following drawing for details:

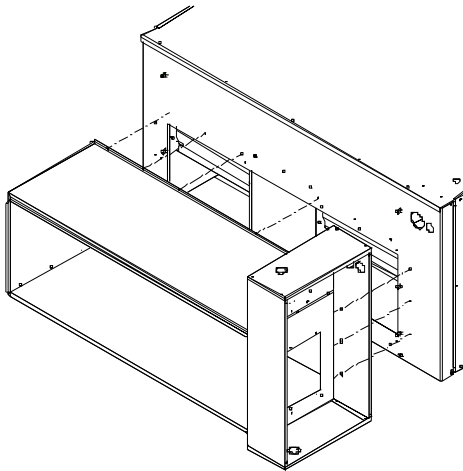

The wires from the heat kit are to be routed through the pipe nipple into the air handler electrical compartment. See the “Electrical Connection” section of this manual for wiring details.

Refrigerant Lines

WARNING
This product is factory-shipped under pressure. Follow these instructions to prevent injury.

WARNING
A quenching cloth is strongly recommended to prevent scorching or marring of the equipment finish when welding close to the painted surfaces. Use brazing alloy of 5% minimum silver content.

Tubing Preparation

All cut ends are to be round, burr free, and clean. Failure to follow this practice increases the chances for refrigerant leaks. The suction line is spun closed and requires pipe cutters to remove the closed end.

Post Brazing

Quench all welded joints with water or a wet rag.

Piping Size

For the correct tubing size, follow the specification for the condenser/heat pump.

The AR0904 coil is circuited to accept a single suction and liquid line. The AR1204 evaporator coil has (2) suction lines and (2) liquid lines. When using a single outdoor unit with the AR1204, it is necessary to manifold the suction lines into a single connection. Similarly, the liquid lines of the AR1204 are to be manifolded when matched with a single condenser/heat pump. See the following sketch for additional details.

CAUTION
Applying too much heat to any tube can melt the tube. Torch heat required to braze tubes of various sizes must be proportional to the size of the tube. Service personnel must use the appropriate heat level for the size of the tube being brazed.

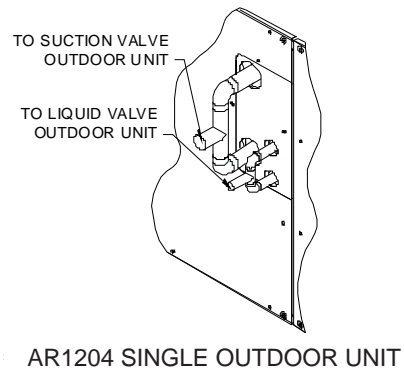
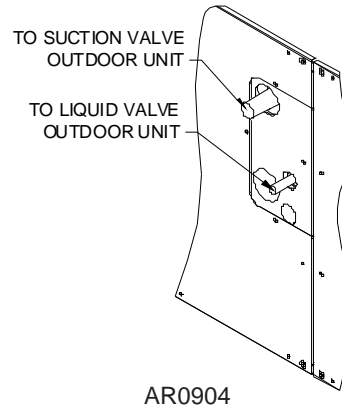

Note: The resulting manifolds are to be sized to accept the suction and liquid line diameters prescribed within the condenser Installation Manual.

Multiple Condensers The AR1204 can accept (2) condensers/ heat pumps. When using two condensers use the following piping procedure:

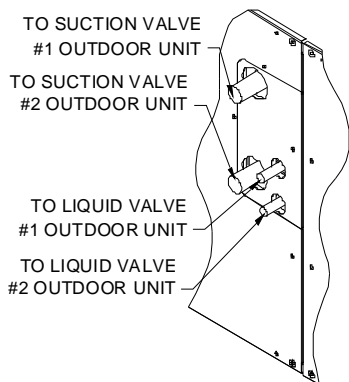

AR1204 TWO OUTDOOR UNITS

IMPORTANT NOTE: Torch heat required to braze tubes of various sizes is proportional to the size of the tube. Tubes of smaller size require less heat to bring the tube to brazing temperature before adding brazing alloy. Applying too much heat to any tube can melt the tube. Service personnel must use the appropriate heat level for the size of the tube being brazed.

NOTE: The use of a heat shield when brazing is recommended to avoid burning the serial plate or the finish on the unit. Heat trap or wet rags should be used to protect heat sensitive components such as service valves and TXV valves.

Evaporator Coil TXV

Note: Thermal Expansion Valve (TXV) Bulb is not permanently connected to the suction from the factory. After suction and liquid line tubing is brazed in the field, the TXV bulb must be attached and insulation to the suction line(s) inside the cabinet at the 10 or 2 o'clock position. This location will be different depending on the orientation of the unit, vertical or horizontal. Always locate the TXV bulb on the top of the suction tube at 10 or 2 o'clock.

For the majority of installation, no adjustment to the TXV setting is required. However, if the measured superheat is less than 8° or greater than 20° an adjustment is required. The adjustment stem is at the base of the valve (opposite the diaphragm) under a flair nut.

To increase the superheat (when measured at the condenser base valve) turn the stem clockwise (in). Similarly to decrease the superheat turn the stem out (counterclockwise). Use a 1/4" refrigeration wrench for this function.

Check condensing unit / heat pump instructions for charging method.

Airflow

The blower uses a belt drive motor that has an adjustable sheave. The factory setting for the AR0904 is 2 turns open and the AR1204 is 3 turns open.

To increase the airflow:

- Remove the blower belt
- Loosen the set screw as shown below

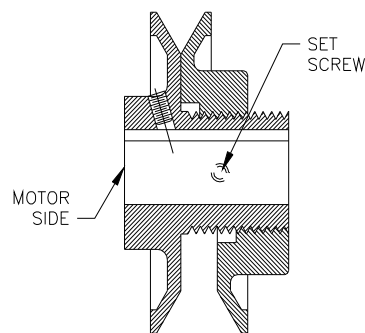

- With the sheave stationary - rotate the other half clockwise (screw in).
- Tighten the set screw
- Reinstall the belt

To decrease the airflow perform the same as above but rotate the sheave counterclockwise (screw out).

The following table can be used as guide for system airflow:

AR0904

Static Pressure	Sheave Turns Open				
	1	2	3	4	5
0.1	4264	3930	3633	3273	
0.2	3996	3705	3325	2998	
0.3	3731	3379	3002	2517	
0.4	3445	3066	2613	-	
0.5	3113	2662	-	-	

AR1204

Static Pressure	Sheave Turns Open					
	1	1	2	3	4	5
0.1	5193	5037	4790	4529	4097	4097
0.2	5012	4873	4603	4315	3842	3842
0.3	4852	4675	4393	4091	3589	3589
0.4	4687	4484	4172	3853	3295	3073
0.5	4501	4268	3939	3561	2922	2610
0.6	4293	4041	3673	3223	2642	-
0.7	4073	3782	3347	2892	-	-
0.8	3807	3485	2962	-	-	-
0.9	3540	3117	-	-	-	-

Belt Tension

The belt tension is to be checked at the time of installation and after a “run in” period of about 24 hours. To perform the measurement, it is suggested that a “Belt Tension Gauge” (available from most belt manufacturers) be used. The force required to deflect the belt 1/8" (at the midpoint) should be between 3 ½ and 5 pounds.

Regular Maintenance

The only item to be maintained on a regular basis by the user is the circulating air filter(s). Filter should be cleaned or replaced regularly.



WARNING

HIGH VOLTAGE!
 Disconnect ALL power before servicing or installing this unit. Multiple power sources may be present. Failure to do so may cause property damage, personal injury or death.



Routine maintenance is essential for trouble free operation of this Airhandler. A few preseason checks can eliminate costly repairs and down time.

A certified service technician must perform all services mentioned below.

1. Check and change air filters as needed
2. Check, adjust or replace belts and check sheaves for proper operation.
3. Clean the evaporator coil and check for duct leaks.
4. Check for proper charge and (or) for refrigerant leaks.

If these few precautions are observed and maintained, this Airhandler can provide years of trouble free service.

WIRING DIAGRAM

WARNING
 HIGH VOLTAGE!
 DISCONNECT ALL POWER BEFORE SERVICING OR INSTALLING THIS UNIT. MULTIPLE POWER SOURCES MAY BE PRESENT. FAILURE TO DO SO MAY CAUSE PROPERTY DAMAGE, PERSONAL INJURY OR DEATH.

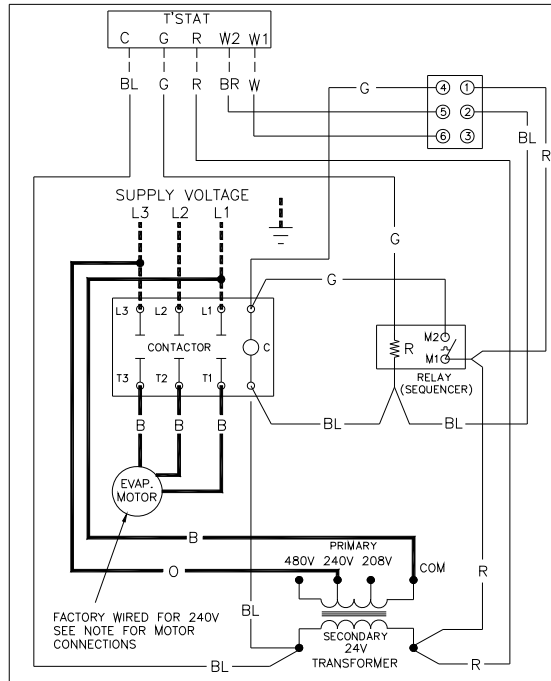

NOTES

- 1) ALL REPLACEMENT WIRES MUST BE SAME GAUGE AND TYPE.
- 2) TO CHANGE VOLTAGE FROM 240V TO 208V, MOVE WIRE FROM 240V TAP TO 208V TAP AT TRANSFORMER PRIMARY.
- 3) TO CONVERT VOLTAGE FROM 240V TO 460V:
 - a) MOVE WIRE FROM 240V TAP TO 480V TAP AT TRANSFORMER PRIMARY.
 - b) IDENTIFY MODEL (i.e. AR090 OR AR120) AND REWIRE MOTOR FROM LOW VOLTAGE (240V) TO HIGH VOLTAGE (480V) ACCORDING TO INSTRUCTION BELOW.

COLOR CODE

B — BLACK
 BL — BLUE
 BR — BROWN
 G — GREEN
 O — ORANGE
 R — RED
 W — WHITE

WIRING CODE

FACTORY WIRING ———
 HIGH VOLTAGE ———
 LOW VOLTAGE ———
 FIELD WIRING ———
 HIGH VOLTAGE - - - - -
 LOW VOLTAGE - - - - -

A.O. SMITH MOTORS

AR120 MOTOR (B3240006)

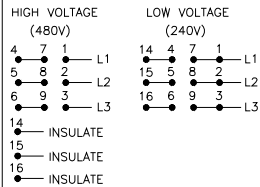

AR090 MOTOR (B3240002)

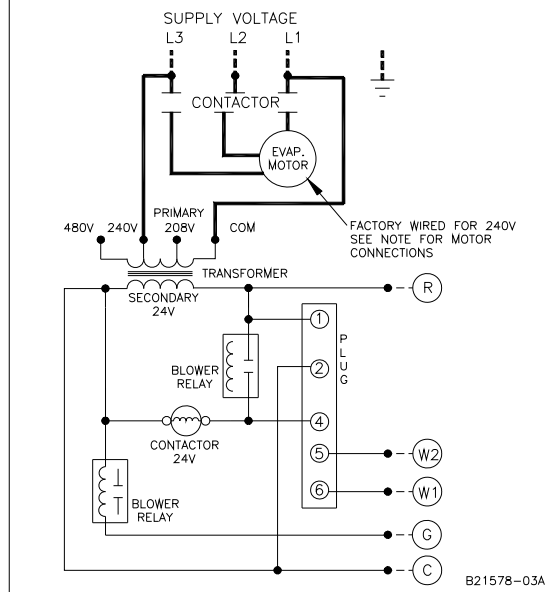
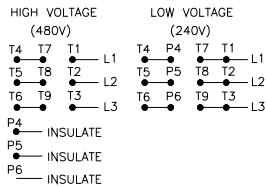

Wiring is subject to change, always refer to the wiring diagram on the unit for the most up-to-date wiring.