

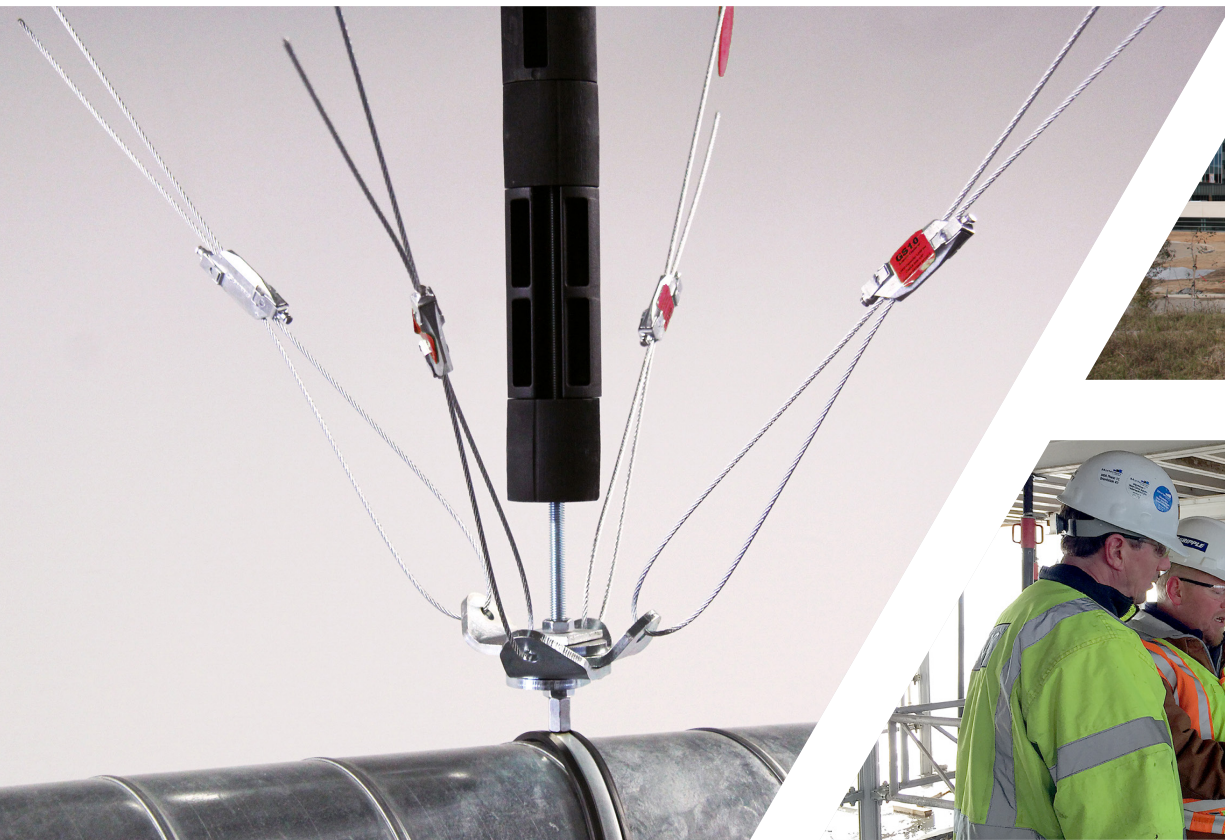

Seismic & Force Protection

For Non-Structural Building Components



- Engineering services
- Cable bracing systems
 - Vibration Isolation
- Meets all seismic design code requirements

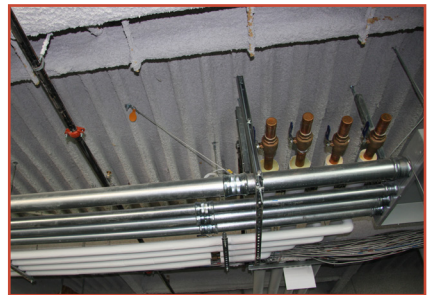
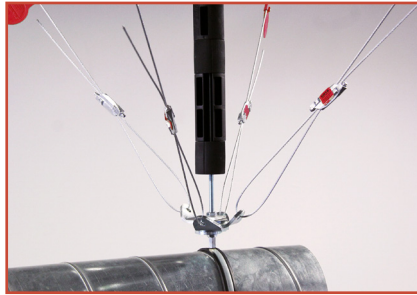

HEATING, VENTILATION, PLENUM BOXES, CHILLED BEAMS, OVAL, SPIRAL & RECTANGULAR DUCT, COLD ROOMS, AIR CONDITIONING UNITS, MECHANICAL, PIPING, CABLE LADDER, BASKET & TRAY, BRACING.

Contents

| | |
|--|-----------|
| Introduction to Gripple® Seismic | 4 |
| What we do | 5 |
| Seismic Bracing | |
| Vibration Isolation | |
| Cable Bracing | 8 |
| The System | |
| Components | 9 |
| Component Dimensions | 10 |
| Kit codes | 12 |
| Labor Savings | 13 |
| Rod Stiffener | 14 |
| Installation | |
| Dimensions | |
| Load Capabilities | 15 |
| Vibration Management | 16 |
| Suspended Vibration Isolation Spring (CD-CH) | 17 |
| Suspended Vibration Isolation Spring (CD-CH30) | 18 |
| Suspended Vibration Isolation - Neoprene (RH and RHD) | 19 |
| Suspended Vibration Isolation - Spring & Neoprene (HH30) | 20 |
| Floor Mounted Vibration Isolation - Spring (OSA) | 21 |
| Floor Mounted Vibration Isolation - Spring (DLK) | 22 |
| Neoprene Ribbed Pad (RP) | 23 |
| Engineering Services | 24 |
| Approvals & Certification | 25 |
| Case Studies | 26 |
| Gripple Seismic Projects | 28 |
| Our Company | 29 |
| Seismic Zones | 30 |

Introduction

Gripple provides complete turn-key seismic and force protection solutions for your project's nonstructural equipment and components requiring seismic design or Anti-Terrorism / Force Protection (AT/FP).



Gripple Seismic products have been utilized on an extensive number of high-profile job sites around the world that include:

Research labs

Educational institutions

Healthcare facilities

Manufacturing plants

Government & military sites

Hotels, casinos and
entertainment venues

Data centers

Education

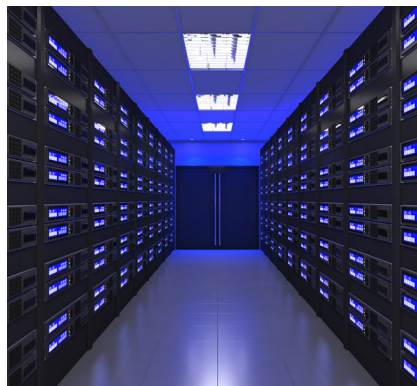

What we do

Seismic Bracing

Suspended nonstructural building components are critical for the proper functioning of a building, and make up a high percentage of a building's damage in a seismic event. Properly engineered bracing and isolation of these services is particularly critical for essential facilities that must remain operational in the aftermath of an earthquake or seismic event (such as hospitals, fire/rescue, water/power, etc.), or facilities representing a substantial hazard to human life (such as schools, jails, etc.).

Part of Gripple's services include providing the right products and services that meet the various seismic design requirements of your project, taking into consideration such factors as:

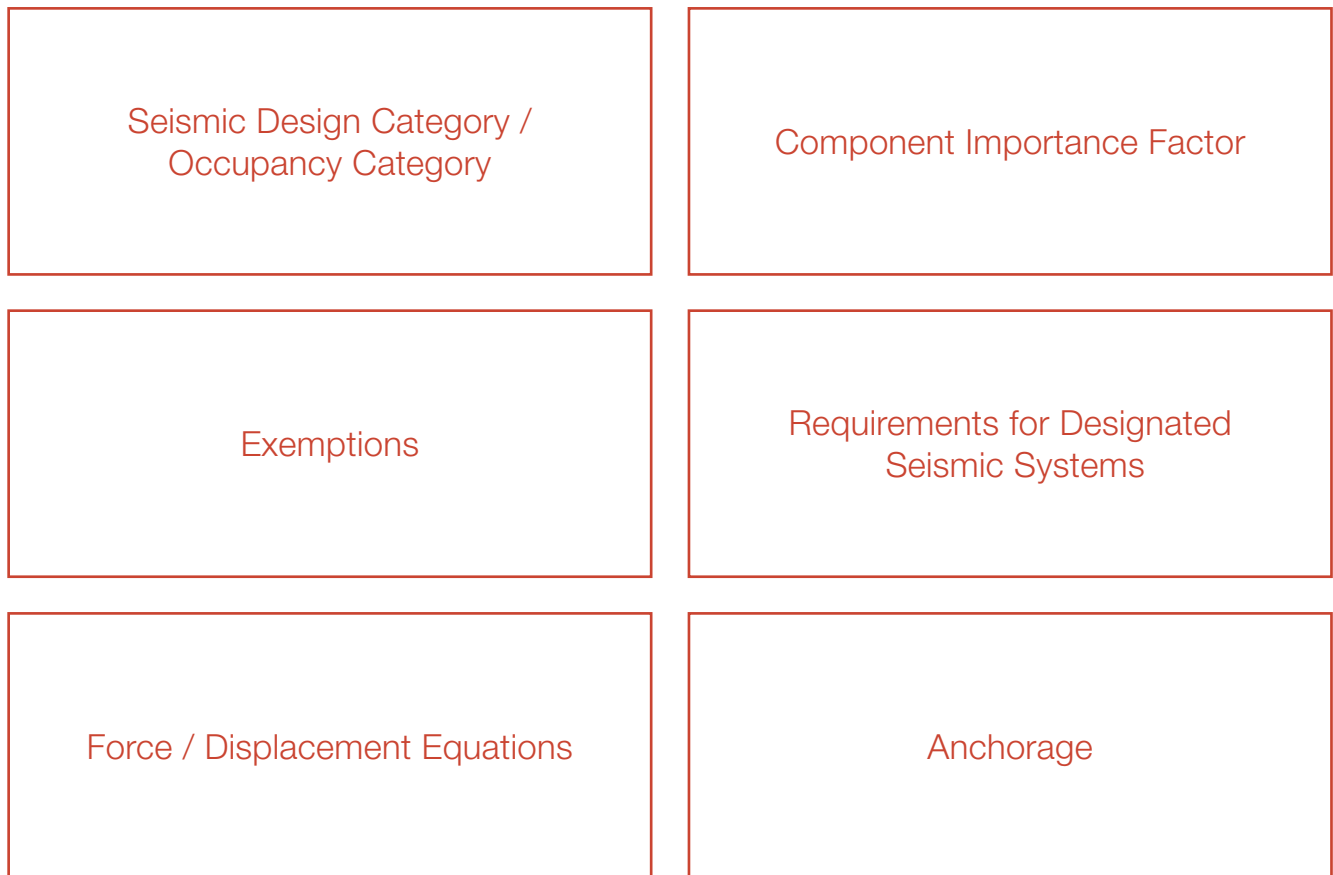

Vibration Isolation

A full selection of vibration and noise isolation products are available in North America through your Gripple Inc. Territory Manager or representative.

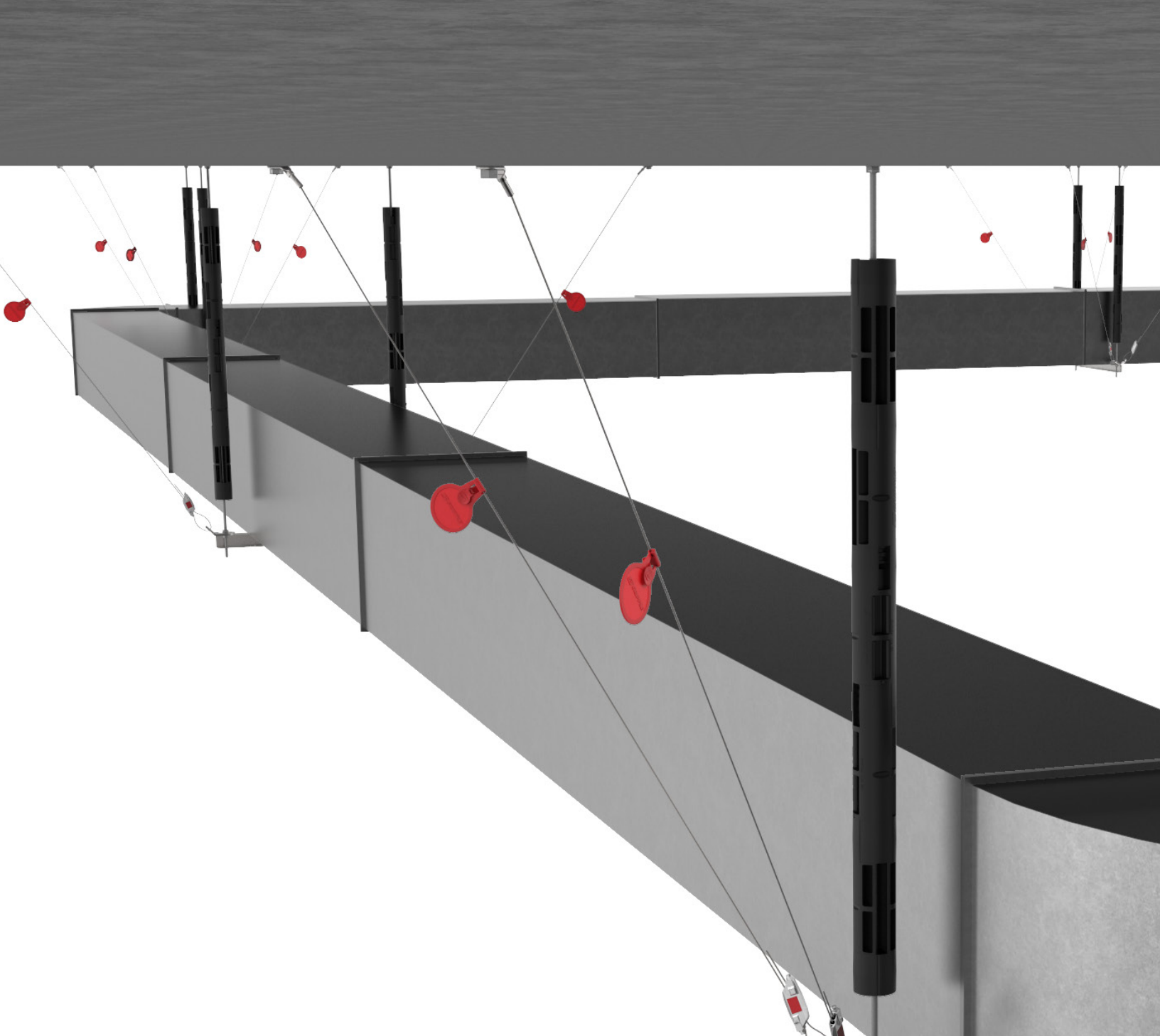

The Gripple range of seismic cable bracing systems are specifically designed & engineered to brace and secure suspended non-structural components.

Gripple products are designed to save time, labor and reduce costs by making the installation quicker and easier. Supplied in ready-to-use kits, the products in this range require no on-site cutting and eliminate the need for on-site fabrication/assembly, offering enormous health and safety benefits for your project.

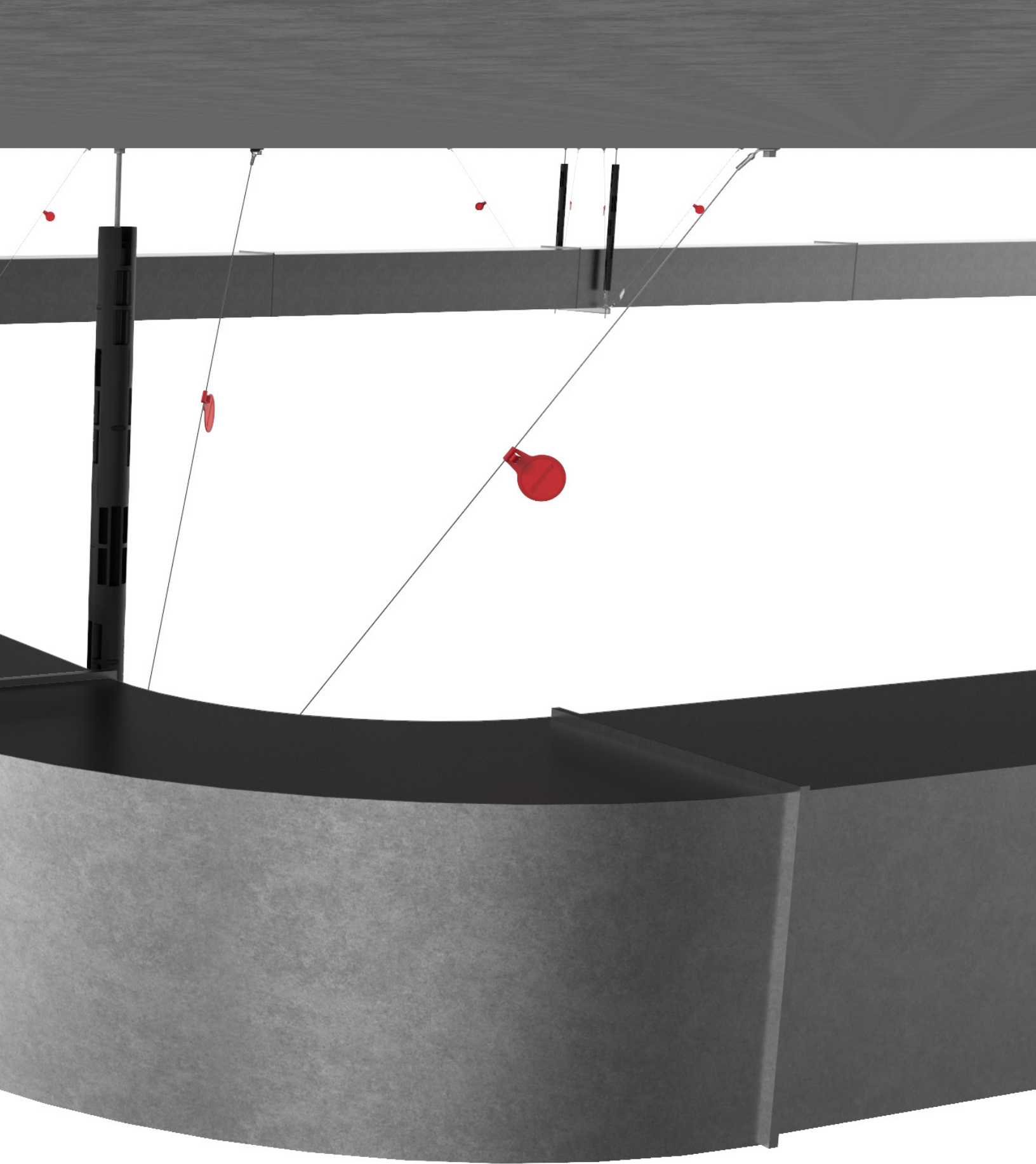

Gripple seismic kits provide “out of the box” solutions for non-structural building components

Cable Bracing

The System

Gripple Seismic Cable Bracing Systems are specifically designed and engineered to brace and secure suspended nonstructural equipment (VAV boxes, fans, unit heaters, small in-line pumps, etc.) and components (HVAC duct, conduit/cable tray, and piping) within a building or structure to minimize damage from an earthquake or a seismic event.

Gripple Seismic Bracing systems are ideal for use on nonstructural components and equipment requiring seismic design, such as in essential facilities that are required for emergency operations in the aftermath of an earthquake.

Gripple Seismic Cable Bracing Systems offer the following advantages:

- Complete pre-engineered systems
- No field swaging of cables
- Up to 10 times faster to install
- No tools required
- Color coding allows easy field verification from the ground
- Suitable for new or retrofit installations
- Can be used in a variety of bracing configurations (transverse, longitudinal, 4-way)
- Tested to ASHRAE-171
- IAPMO approval
- NFPA 13 compliant
- SMACNA verified
- Tested for NEBS GR 63 Core
- OSHPD OPA 2123-10 approval (GS10, GS12, and GS19 systems)

Complete bracing kits include a length of cable with pre-attached end fitting, color-coded tag, Gripple Seismic fastener, and standard or retrofit bracket. Four kit sizes are available:

| Kit | GS10 | GS12 | GS19 | GS25 |
|-------------------------|---------|---------|-----------|-----------|
| Tag Color | Red | Green | Yellow | Purple |
| Design Strength (LRFD*) | 400 lbf | 945 lbf | 2,265 lbf | 3,570 lbf |

* Note: Specified Load and Resistance Factor Design Strength (LRFD) does not correspond to the component or system weight being braced. Please refer to the project specific engineering documentation for appropriate Gripple Seismic restraint kit selection.



Transverse bracing



Longitudinal bracing



4-Way bracing

Components

There are four Gripple® Seismic cable bracing kit sizes available, each with its own Load and Resistance Factor Design (LRFD), selection of cable lengths, pre-attached end fittings, and bracket. As part of our Engineering services, Gripple will ensure that the bracing meets the seismic design requirements of the nonstructural components as related to weight loads and types of connections. Complete Cable Bracing Kits include the following components:

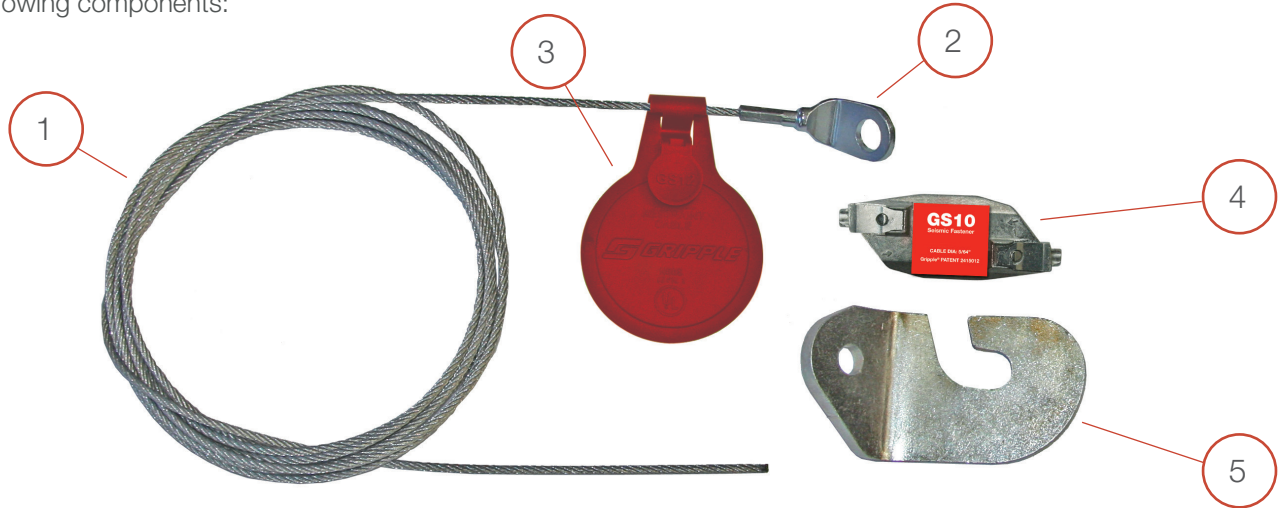

1

Gripple® Seismic Cable

Break strength certified, pre-stretched Gripple® Seismic cable. Available in lengths of 10ft, 15ft, and 20ft.

2

End Fitting



E = 45° Eyelet



S = Standard Bracket
*w/ Zinc plated copper ferrules



DS = Double Standard Bracket
*w/ Zinc plated copper ferrules

3

Color Coded Tag

Pre-assembled color coded tag for attaching to cable for easy field verification of cable diameter. GS10 = Red, GS12 = Green, GS19 = Yellow, GS25 = Purple

4

Gripple Seismic Fastener



5

Loose Bracket

Standard or Retrofit Bracket in Single or Double Bracket configurations.



Standard Bracket



Retrofit Bracket

Component Dimensions

Gripple® Seismic Fastener

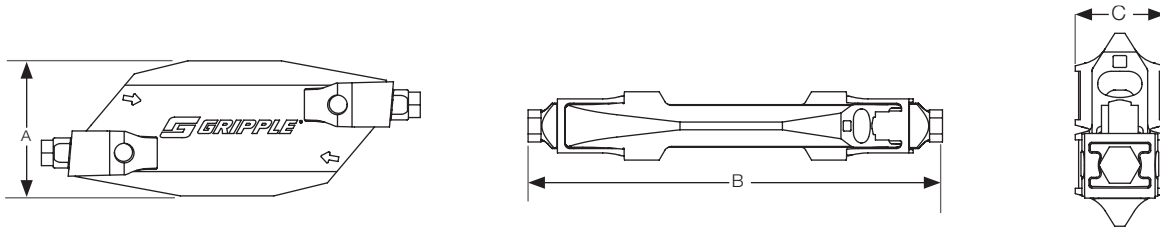

| Brace Size | Dimensions | | | Cable Construction |
|------------------|------------|----------|--------|--------------------|
| | A | B | C | |
| GS10 5/64" cable | 1 9/64" | 2 15/16" | 33/64" | 7x7 |
| GS12 1/8" cable | 1 9/64" | 3 1/4" | 35/64" | 7x7 |
| GS19 3/16" cable | 1 11/32" | 3 3/4" | 9/16" | 7x19 |
| GS25 1/4" cable | 1 23/32" | 4 23/32" | 11/16" | 7x19 |

Eyelet End Fitting

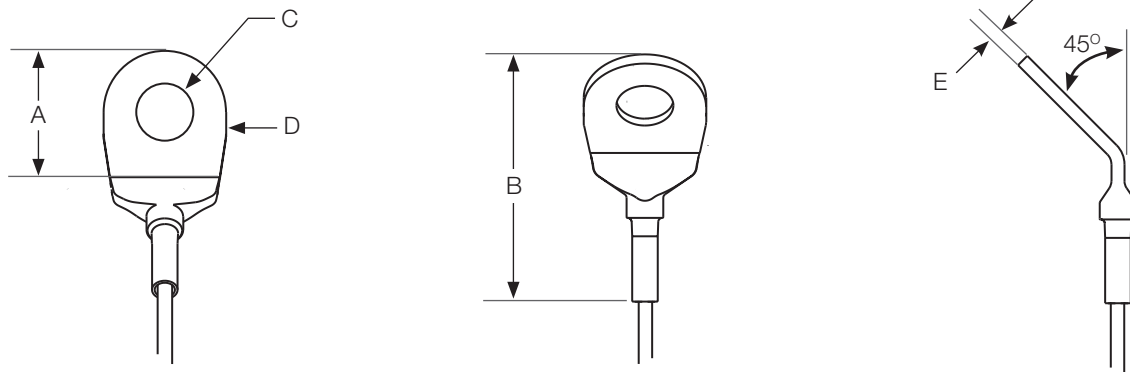

| Eyelet Size | Dimensions | | | | |
|-------------|------------|----------|-------|--------|------|
| | A | B | C Ø | D | E |
| GSE4 | 1" | 1 29/32" | 7/16" | 13/16" | 1/8" |

Standard Bracket

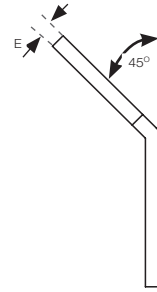
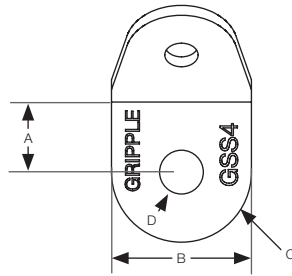
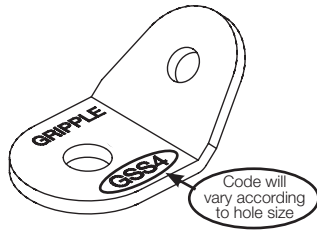

| Standard Bracket Size | Dimensions | | | | |
|-----------------------|-------------|--------------|--------------|-------------|----------|
| | A | B | C ϕ | D ϕ | E |
| GSS4 | $25/32$ " | $1\ 9/16$ " | $1\ 9/16$ " | $7/16$ " | $5/32$ " |
| GSS5 | $13/16$ " | $1\ 9/16$ " | $1\ 21/32$ " | $9/16$ " | $5/32$ " |
| GSS6 | $13/16$ " | $1\ 9/16$ " | $1\ 21/32$ " | $11/16$ " | $5/32$ " |
| GSS8 | 1" | $1\ 31/32$ " | $1\ 31/32$ " | $13/16$ " | $5/32$ " |
| GSS10 | $1\ 1/16$ " | $1\ 31/32$ " | $1\ 31/32$ " | $1\ 5/64$ " | $5/32$ " |

Retrofit Bracket

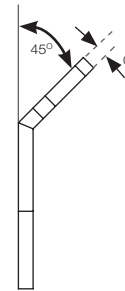
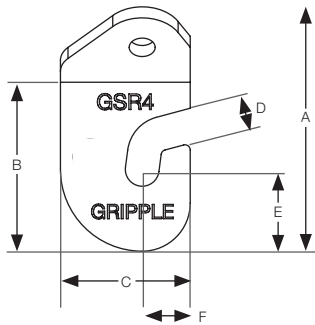
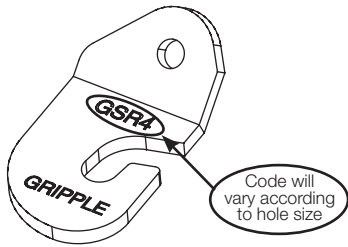

| Retrofit Bracket Size | Dimensions | | | | | | |
|-----------------------|--------------|--------------|--------------|-------------|--------------|-----------|---------|
| | A | B | C | D | E | F | G |
| GSR4 | $3\ 45/64$ " | $2\ 9/16$ " | $1\ 31/32$ " | $7/16$ " | $1\ 17/64$ " | $45/64$ " | $1/4$ " |
| GSR5 | $3\ 3/4$ " | $2\ 41/64$ " | $1\ 31/32$ " | $9/16$ " | $1\ 19/64$ " | $45/64$ " | $1/4$ " |
| GSR6 | $3\ 3/4$ " | $2\ 41/64$ " | $1\ 31/32$ " | $11/16$ " | $1\ 19/64$ " | $45/64$ " | $1/4$ " |
| GSR8 | $4\ 9/64$ " | $3\ 1/16$ " | $2\ 1/4$ " | $13/16$ " | $1\ 3/8$ " | $55/64$ " | $1/4$ " |
| GSR10 | $9\ 7/16$ " | $1\ 31/32$ " | $3\ 5/16$ " | $1\ 1/16$ " | $1\ 17/32$ " | $29/32$ " | $1/4$ " |

Kit Codes

| Kit Size | Kit Length | Structural Attachment Size (in.) | Rod Attachment Size (in.) | Product Code |
|-------------------------------------|------------|-------------------------------------|---------------------------|-----------------|
| GS10 | 10ft | 3/8 | 3/8 | GS10-10E4-R4-2P |
| | | | 1/2 | GS10-10E4-R5-2P |
| | | | 5/8 | GS10-10E4-R6-2P |
| | | | 3/4 | GS10-10E4-R8-2P |
| | | 1/2 | 3/8 | GS10-10S5-R4-2P |
| | | | 1/2 | GS10-10S5-R5-2P |
| | | | 5/8 | GS10-10S5-R6-2P |
| | | | 3/4 | GS10-10S5-R8-2P |
| | | 5/8 | 3/8 | GS10-10S6-R4-2P |
| | | | 1/2 | GS10-10S6-R5-2P |
| | | | 5/8 | GS10-10S6-R6-2P |
| | | | 3/4 | GS10-10S6-R8-2P |
| | | 3/4 | 3/8 | GS10-10S8-R4-2P |
| | | | 1/2 | GS10-10S8-R5-2P |
| | | | 5/8 | GS10-10S8-R6-2P |
| | | | 3/4 | GS10-10S8-R8-2P |
| Also available in 15 & 20ft lengths | | (S) Standard Bracket Also Available | | |

| Kit Size | Kit Length | Structural Attachment Size (in.) | Rod Attachment Size (in.) | Product Code |
|-------------------------------------|------------|-------------------------------------|---------------------------|-----------------|
| GS12 | 10ft | 3/8 | 3/8 | GS12-10E4-R4-2P |
| | | | 1/2 | GS12-10E4-R5-2P |
| | | | 5/8 | GS12-10E4-R6-2P |
| | | | 3/4 | GS12-10E4-R8-2P |
| | | 1/2 | 3/8 | GS12-10S5-R4-2P |
| | | | 1/2 | GS12-10S5-R5-2P |
| | | | 5/8 | GS12-10S5-R6-2P |
| | | | 3/4 | GS12-10S5-R8-2P |
| | | 5/8 | 3/8 | GS12-10S6-R4-2P |
| | | | 1/2 | GS12-10S6-R5-2P |
| | | | 5/8 | GS12-10S6-R6-2P |
| | | | 3/4 | GS12-10S6-R8-2P |
| | | 3/4 | 3/8 | GS12-10S8-R4-2P |
| | | | 1/2 | GS12-10S8-R5-2P |
| | | | 5/8 | GS12-10S8-R6-2P |
| | | | 3/4 | GS12-10S8-R8-2P |
| Also available in 15 & 20ft lengths | | (S) Standard Bracket Also Available | | |

| Kit Size | Kit Length | Structural Attachment Size (in.) | Rod Attachment Size (in.) | Product Code |
|-------------------------------------|------------|-------------------------------------|---------------------------|-----------------|
| GS19 | 10ft | 3/8 | 3/8 | GS19-10S4-R4-2P |
| | | | 1/2 | GS19-10S4-R5-2P |
| | | | 5/8 | GS19-10S4-R6-2P |
| | | | 3/4 | GS19-10S4-R8-2P |
| | | 1/2 | 3/8 | GS19-10S5-R4-2P |
| | | | 1/2 | GS19-10S5-R5-2P |
| | | | 5/8 | GS19-10S5-R6-2P |
| | | | 3/4 | GS19-10S5-R8-2P |
| | | 5/8 | 3/8 | GS19-10S6-R4-2P |
| | | | 1/2 | GS19-10S6-R5-2P |
| | | | 5/8 | GS19-10S6-R6-2P |
| | | | 3/4 | GS19-10S6-R8-2P |
| | | 3/4 | 3/8 | GS19-10S8-R4-2P |
| | | | 1/2 | GS19-10S8-R5-2P |
| | | | 5/8 | GS19-10S8-R6-2P |
| | | | 3/4 | GS19-10S8-R8-2P |
| Also available in 15 & 20ft lengths | | (S) Standard Bracket Also Available | | |

| Kit Size | Kit Length | Structural Attachment Size (in.) | Rod Attachment Size (in.) | Product Code |
|----------|------------|----------------------------------|-------------------------------------|---------------------|
| GS25 | 10ft | 3/8 | 5/8 | GS25-10DS6-DR6-2P |
| | | | 3/4 | GS25-10DS6-DR8-2P |
| | | | 1 | GS25-10DS6-DR10-2P |
| | | 1/2 | 3/8 | GS25-10DS8-DR6-2P |
| | | | 1/2 | GS25-10DS8-DR8-2P |
| | | | 5/8 | GS25-10DS8-DR10-2P |
| | | 5/8 | 3/8 | GS25-10DS10-DR6-2P |
| | | | 1/2 | GS25-10DS10-DR8-2P |
| | | | 5/8 | GS25-10DS10-DR10-2P |
| | | | Also available in 15 & 20ft lengths | |

* Note: Specified Load and Resistance Factor Design Strength (LRFD) does not correspond to the component or system weight being braced. Please refer to the project specific engineering documentation for appropriate Gripple Seismic restraint kit selection.

Example Code:

| | | | | | | | | | | | |
|------------|--------------|------------------------------|------------------|---|---------------------------------|--------------------|----------|----------|---|----------|----------|
| G | S | 1 | 2 | - | 1 | 0 | E | 4 | - | S | 4 |
| = | = | = | = | | = | = | = | = | | = | |
| Cable Size | Cable Length | End Fitting | End Fitting Size | | Style of Loose Bracket | Loose Bracket Size | | | | | |
| GS10=5/64" | 10 ft | E = 45° Eyelet | 4=3/8 | | S=Standard Bracket | 4=3/8" | | | | | |
| GS12=1/8" | 15 ft | S = Standard Single Bracket | 5=1/2" | | R=Retrofit Bracket | 5=1/2" | | | | | |
| GS19=3/16" | 20 ft | DS = Standard Double Bracket | 6=5/8" | | DS=Double Standard Bracket | 6=5/8" | | | | | |
| GS25=1/4" | | | 8=3/4" | | DR=Double Retrofit Bracket | 8=3/4" | | | | | |
| | | | 10= 1" | | (Double brackets for GS25 only) | 10= 1" | | | | | |

Gripple® Seismic Technical Installation manual should be consulted when designing or installing Gripple Seismic bracing kits.

Time Savings

Gripple Seismic provides the fastest cable braces on the market, saving contractors time and money due to the speed of installation over traditional rigid bracing or hand bolted/crimped cable methods. This allows the contractor to complete their installation and move onto the next job quicker, ensuring that they stay steps ahead of the competition.



Rod Stiffener

Product Information

Used to prevent threaded rod from buckling vertically during seismic activity or blast events.

- An innovative alternative to stiffening threaded rod without using struts, pipes, or clamps
- Much Faster Installation Time - Compared to traditional rod stiffening
- Lightweight Solution - Up to 80% lighter than strut/pipe & clamp methods
- No Tools Required - Click and connect mechanism
- Enhances Health & Safety - Lighter products and a reduction in time working at heights to install ensures a safer working environment
- Versatile Design - The 'crush tooth' design allows Gripple's Rod Stiffener to be installed on 3/8" threaded rod
- 'Out of the Box' Installation - Removes the need to cut steel strut/pipe
- Applications on drops up to 5ft/1.5m



Installation

1.

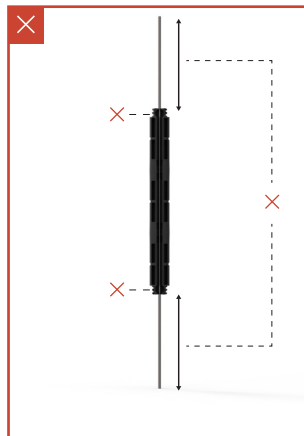
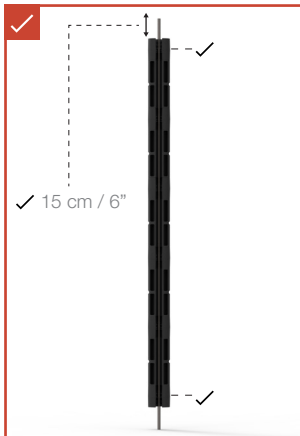

2.

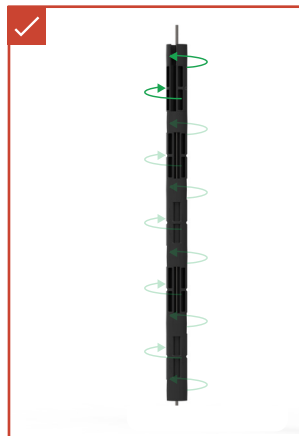

Assemble appropriate number of components to fit threaded rod size. Ensure a coupling is present at both ends of the assembly.

Rotate each individual component until a hard stop is reached.

Dimensions

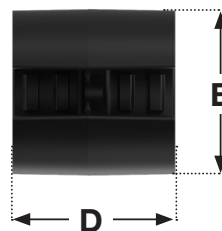

| A (in) | B (in) | C (in) | D (in) | E (in) |
|--------|--------|--------|--------|--------|
| 4.75 | 6.7 | ø2.15 | 2.15 | ø2.2 |

Load Capabilities

The Gripple Rod Stiffener is used to stiffen threaded rod against vertical compression.

| Rod size | | Drop length | Load rating (lbf) (Stiffened) |
|----------|------|-------------|----------------------------------|
| ft | 3/8" | 2' | 1708 |
| | | 2'3" | 1496 |
| | | 2'6" | 1283 |
| | | 2'9" | 1071 |
| | | 3 | 858 |
| | | 3'3" | 783 |
| | | 3'6" | 708 |
| | | 3'9" | 633 |
| | | 4 | 558 |
| | | 4'3" | 501 |
| | | 4'6" | 444 |
| | | 4'9" | 386 |
| | | 5 | 329 |

Material Specification

Rod range:

3/8"

Material:

Polypropylene (PP),
22% Glass Filled Polypropylene
(22GFPP)

Weight:

Body piece - 6 oz / 170 gm
Coupling piece - 3 oz / 88 gm
Weight per ft - 17 oz/ft / 1.6 kg/m

Approvals:

UL2043 -
Plenum

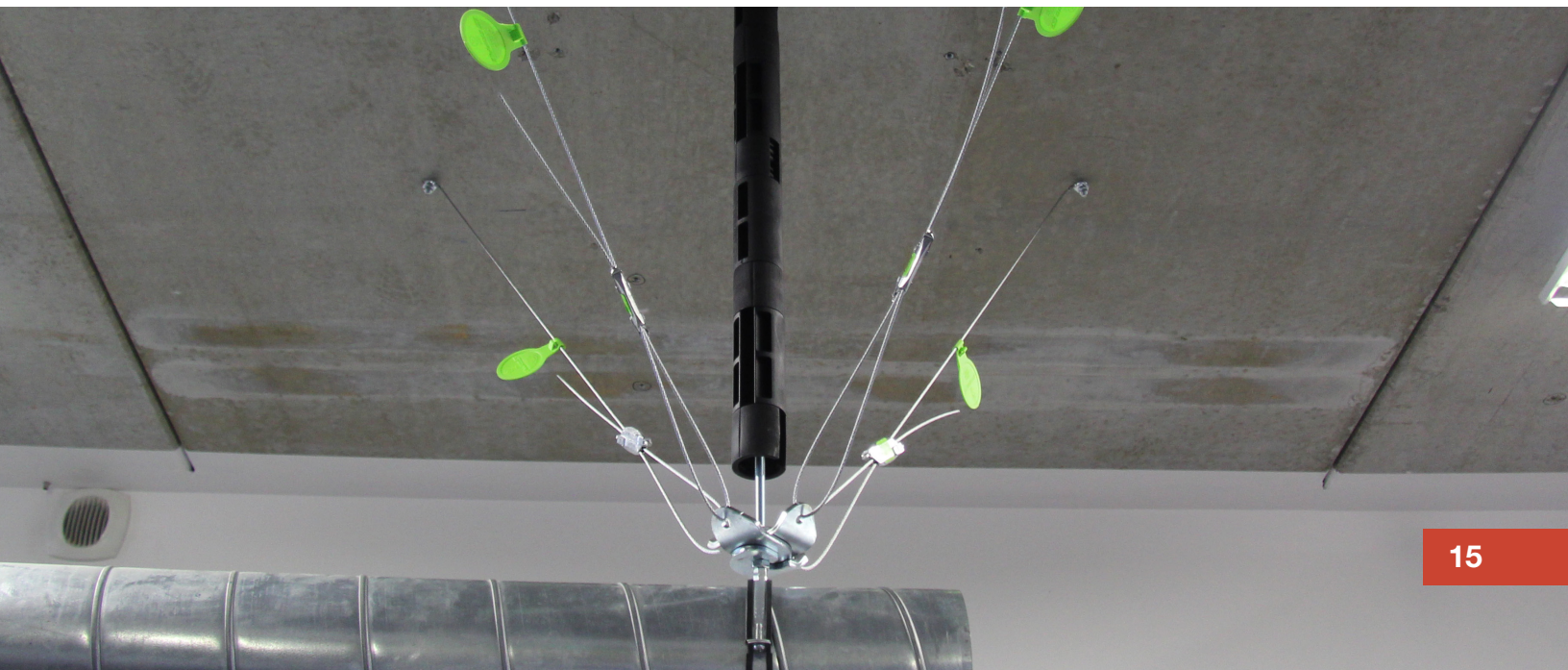

A tall building under construction with a green crane and a blue container in the foreground. The building has a concrete frame and is surrounded by scaffolding. A blue container is visible on the right side, and a green container is visible at the bottom. A red fire extinguisher is also visible in the foreground.

The Gripple range of vibration and noise isolation products provide a fast and versatile solution for all types of nonstructural equipment.

Vibration Isolation

Suspended Vibration Isolation Spring (CD-CH)

- CH 1" Deflection Hangers are specially reinforced for extra strength
- The pre-compression rod is furnished with units which have the "R" option; rod diameter must be specified. This rod will extend about 3" below the bottom of the hanger housing.
- MRD: Rod, Nuts and Washers are by others.
- Minimum additional travel 50% of required deflection at rated load.
- Zinc Finish for Light Weight and Basic Hanger.
- Black Primer Lacquer for the Extra Strength Hanger.
- Dimensions are in inches.

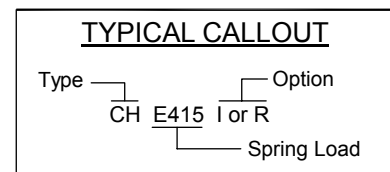
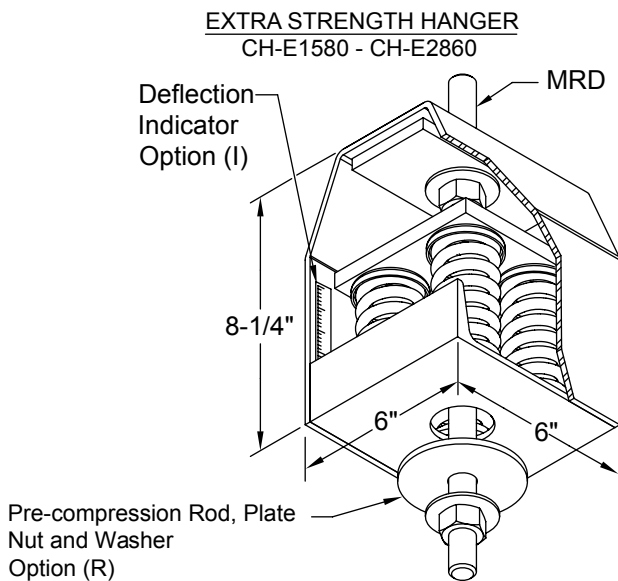
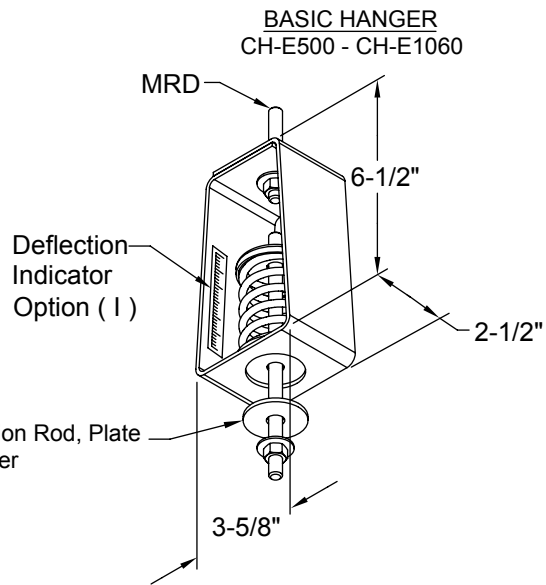
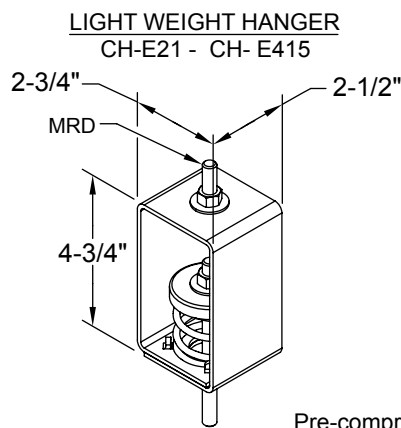

Vibration Isolation

Suspended Vibration Isolation Spring (CD-CH30)

- CH30 1" Deflection Hangers are used where uncertain alignment is anticipated during installation. At normal load the hanger rod will operate to a full 15° tilt in any direction from Vertical Centerline.
- The Extra Strength Hanger housings are specially reinforced for extra strength.
- All housing sizes have been tested to carry 5 times maximum load without failure.
- The pre-compression rod is furnished with units which have the "R" option; specify rod diameter. This rod will extend about 3" below the Neoprene sleeve.
- MRD: Rod, Nuts and Washers by others.
- Zinc plated finish for the Light Weight Hanger and the Basic Hanger.
- Black primer lacquer finish for the Extra Strength Hanger.
- Dimensions are in inches.

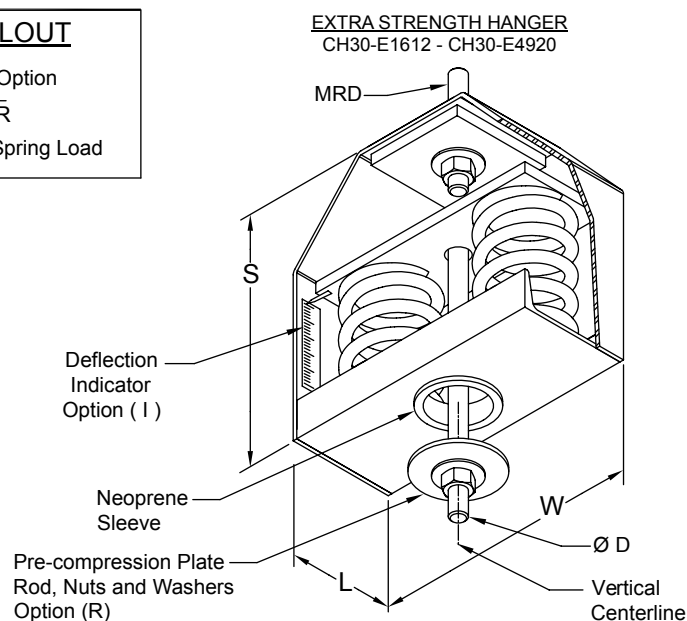
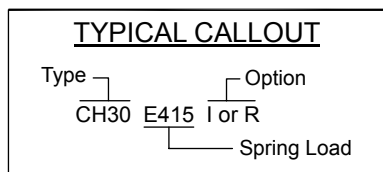
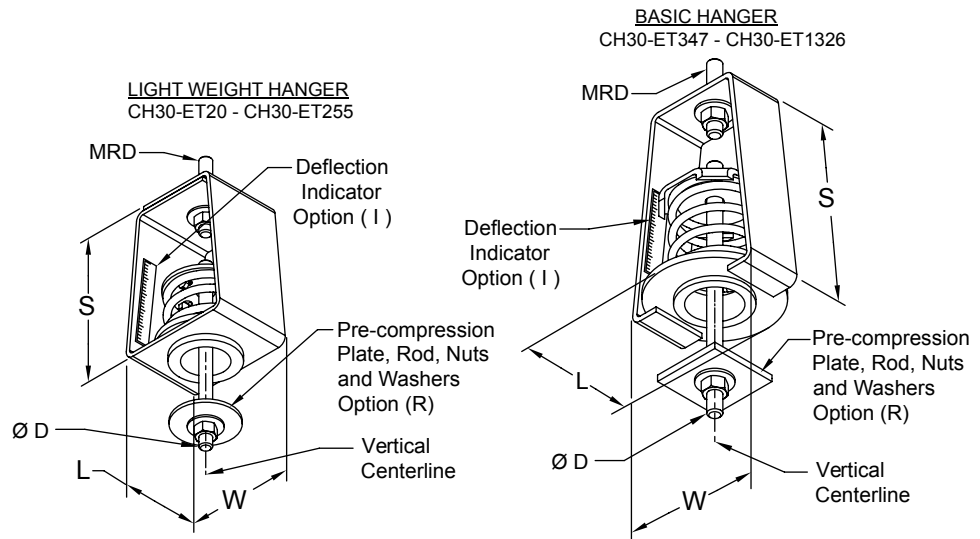
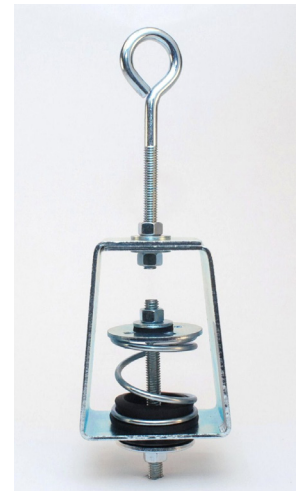

| Max. Load (lbs) | DIMENSIONS (Inches) | | | | |
|-----------------|---------------------|--------|-------|-------|-------|
| | S | W | L | MRD | ØD |
| ET20 | | | | | |
| ET42 | | | | | |
| ET80 | | | | | |
| ET129 | 4-3/4 | 3-5/8 | 2-1/2 | 1/2 | 1/2 |
| ET194 | | | | | |
| ET255 | | | | | |
| ET347 | | | | | |
| ET473 | 6 | 5-5/16 | 4-1/4 | 3/4 | 5/8 |
| ET667 | | | | | |
| ET940 | 7 | 5-7/8 | 4-3/4 | 7/8 | 3/4 |
| ET1326 | | | | | 7/8 |
| E1612 | | | | | |
| E2060 | 8-1/4 | 10 | 4 | 1 | 1 |
| E2460 | | | | | |
| E2980 | | | | | |
| E4120 | 8-1/2 | 9-1/2 | 7 | 1-1/8 | 1-1/8 |
| E4920 | | | | | |

Vibration Isolation

Suspended Vibration Isolation - Neoprene (RH and RHD)

- RH and RHD
- Threaded Rods, Nuts, and Washers are not furnished unless specified in quotation or order.
- Housing finish zinc plated
- TYPE RH: Single Deflection (1/4" maximum)
- TYPE RHD: Double Deflection (1/2" maximum)

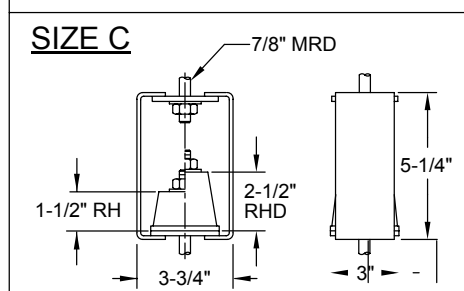
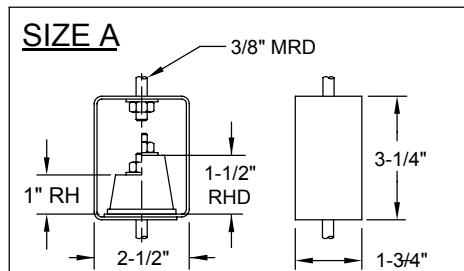
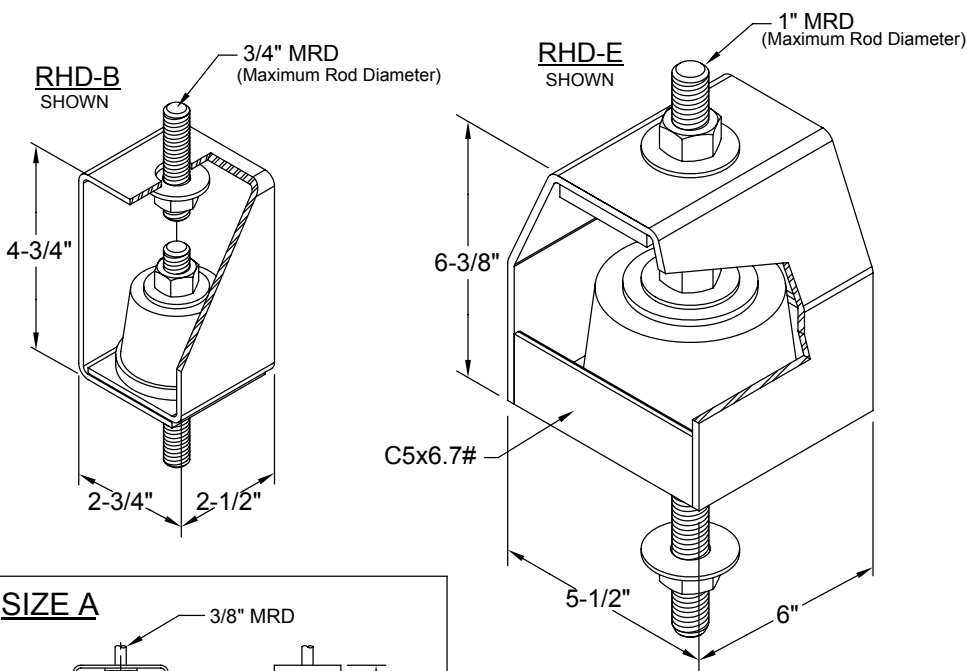
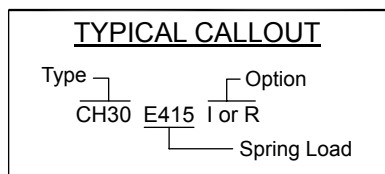

| MAXIMUM LOAD RATING (lbs) | | | | |
|---------------------------|------|-----|------|------|
| COLOR CODE | SIZE | | | |
| | A | B | C | E |
| ORANGE | - | 120 | - | - |
| YELLOW | 40 | 200 | 300 | - |
| GREEN | 55 | 280 | 520 | 1700 |
| BLUE | 80 | 400 | 750 | 2700 |
| WHITE | 130 | - | 1100 | 4200 |

Vibration Isolation

Suspended Vibration Isolation - Spring & Neoprene (HH30)

- HH30 hangers are used where uncertain alignment is anticipated during installation. At normal load the hanger rod will operate to a full 15° tilt in any direction from Vertical Centerline.
- Rated Deflection is 1" + 1/2" Neoprene rated Deflection = 1-1/2".
- The Extra Strength Hanger housings are specially reinforced for extra strength.
- All housing sizes have been tested to carry 5 times maximum load without failure.
- The pre-compression rod is furnished with units which have the "R" option; specify rod diameter. This rod will extend about 3" below the Neoprene sleeve.
- MRD: Rod, Nuts and Washers by others.
- Zinc Plated Finish for the Basic Hanger.
- Black Primer Lacquer Finish for the Extra Strength Hanger.
- Dimensions are in inches.

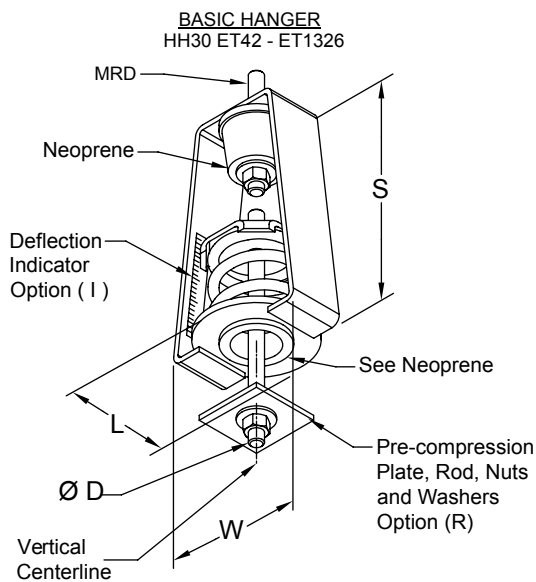

| Max. Load (lbs) | DIMENSIONS (Inches) | | | | |
|-------------------------------|---------------------|--------|-------|-----|-----|
| | S | W | L | MRD | ØD |
| ET20 ET42 ET80 ET129 | 6-1/2 | 3-5/8 | 2-1/2 | 1/2 | 1/2 |
| ET194 ET255 | 7-1/2 | 4 | 3 | 3/4 | 5/8 |
| ET347 ET473 | 8-1/2 | 5-5/16 | 4-1/4 | 7/8 | |
| ET667 ET940 | 10 | 5-7/8 | 4-3/4 | 7/8 | 3/4 |
| ET1326 E1612 | 11-1/4 | 10 | 4 | 1 | 7/8 |
| E2060 E2460 E2980 | | | | | 1 |
| E4120 E4920 | | | | | 1 |
| | | | | | 1 |

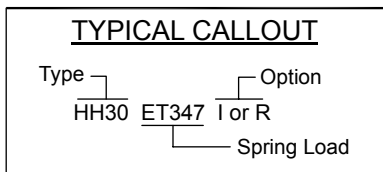
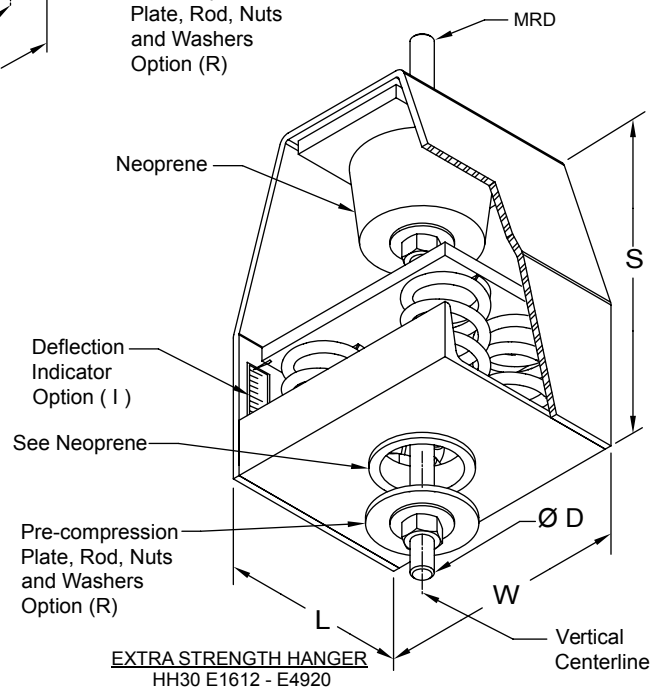

Vibration Isolation

Seismically Restrained Floor Mounted Vibration Isolators - Spring (OSA)

- OS Isolator/Restraints feature large diameter springs with O.D. not less than 80% of rated deflection height.
- Dimensions are in inches.
- Neoprene pad 1/4" thick under spring regardless of style.
- Adjust Load Transfer while Motion Restraint adjustments are loose.
- For compact support of heavy loads, some OS's include inner springs.
- For low profile support of heavy loads, OSE's have clustered springs.
- Available Finishes Hot Dip Galvanized or Zinc Plated.
- Available in 3 different attachment styles, V, U and R.
- Deflections and Spring Capacities
 - 1" Deflection up to 801 lb capacity
 - 2" Deflection up to 300 lb capacity
 - 3" Deflection up to 1,223 lb capacity



Contact Gripple if larger capacities are required.

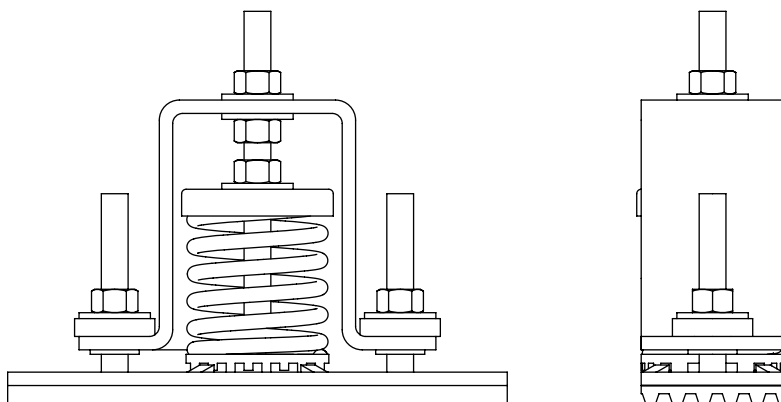
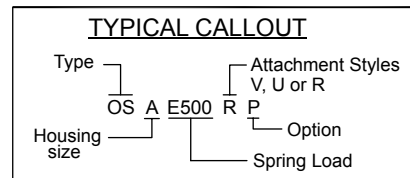
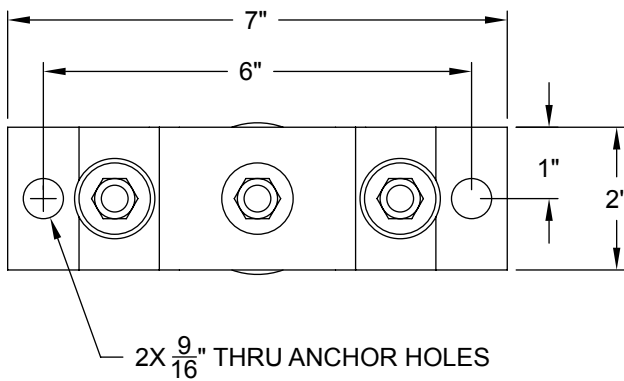

P (Pad OPTION)

Vibration Isolation

Seismically Restrained Floor Mounted Vibration Isolation - Spring (DLK)

- DLK Isolator/Restrains are Job Site Custom Designed.
- Rated Deflections are available in 1", 2", 3" and 4".
- The ratio of the outer spring diameter to its height at rated deflection is not under .8 and extra deflection is not less than 50%. Springs may be clustered as shown and may include inner spring.
- Operating Height is $\pm 10\%$ accurate. Contact Gripple if closer accuracy is needed.
- The pre-compression rod is furnished with units which have the "R" option; specify rod diameter. This rod will extend about 3" below the Neoprene sleeve.
- Available in 3 different attachment styles U, V, and T. Style U shown.
- Available Finishes Hot Dip Galvanized or Primer Black Lacquer.

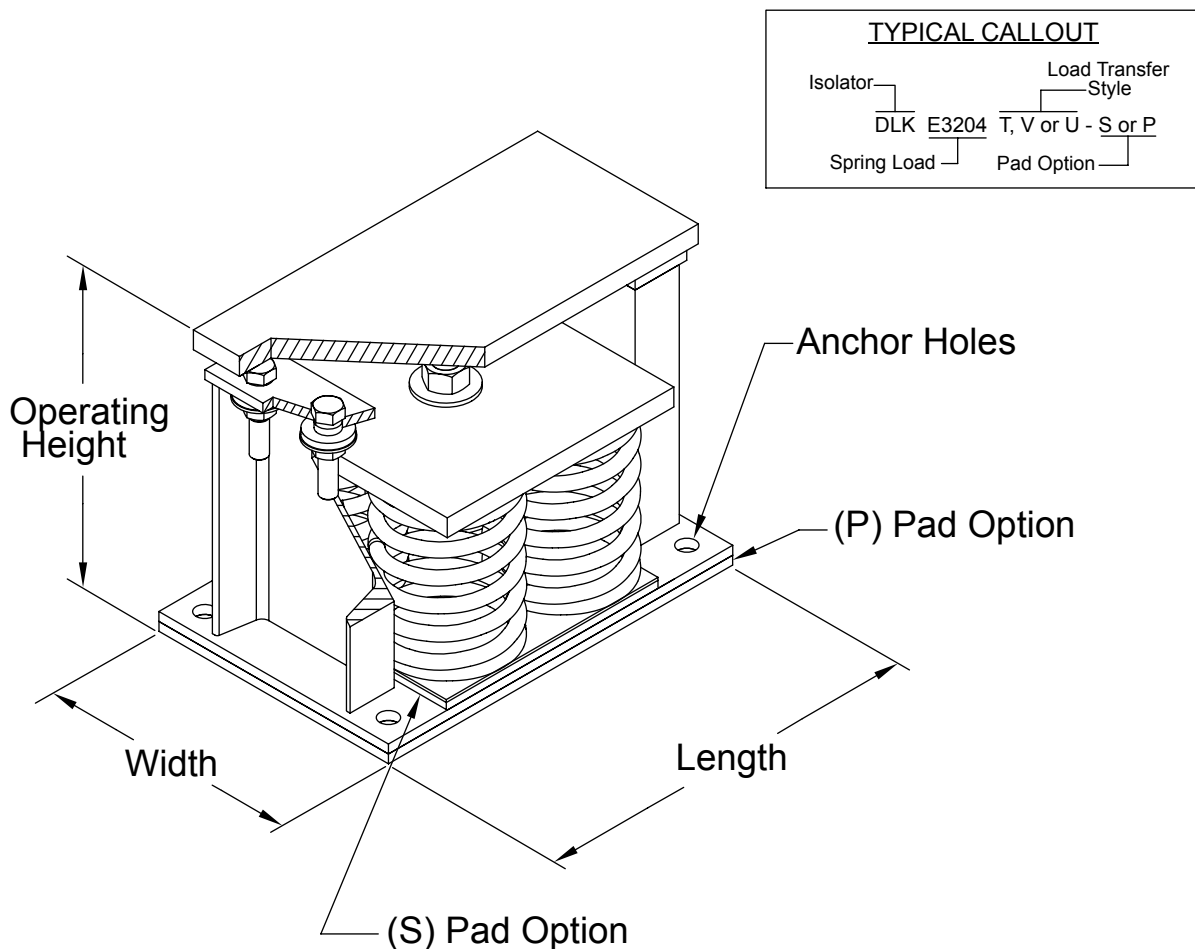
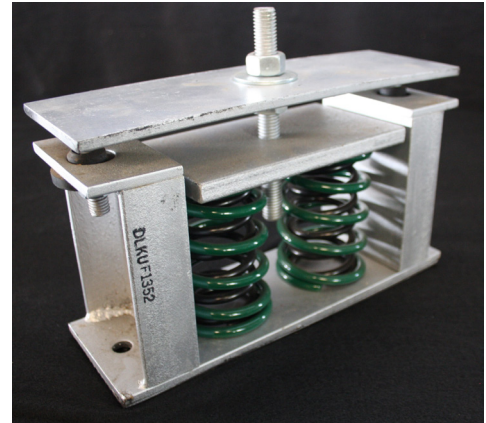

Vibration Isolation

Neoprene Ribbed Pad (RP)

RP Pad

This is useful under equipment of all speeds to minimize transmission of disturbances from entering floor.

High Speed 1500 CPM and Up

RP-PAD eliminates noise and reduces vibration transmitted from:

- Engines
- Transformers
- Pumps and Piping
- Steam Generators
- Crushers

High Speed 250 CPM to 1500 CPM

RP-PAD simplifies mounting and eliminates noise transmitted from:

- Compressor (Tank Mounted)
- Air Conditioners
- Fans

Low Speed 0 to 250 CPM

RP-PAD limits impact shock and noise transmission from:

- Punch Presses
- Shears
- Business Machines
- Hammers and Presses

R Pad

Is useful under equipment to minimize transmission of disturbances from the floor

Low Speed and High Speed 0 to 250 CPM & 1500 CPM & Up

K-PAD protects these sensitive instruments, machines, and devices from low frequency shocks and high frequency vibrations present in the floor:

- Grinders
- Surface Plates
- Machine Tools
- Instruments

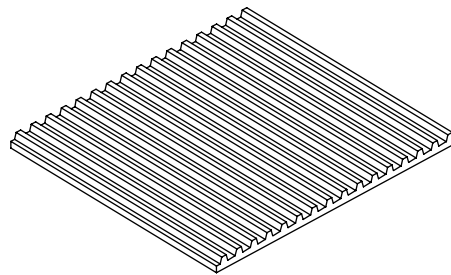

1/4" Thick

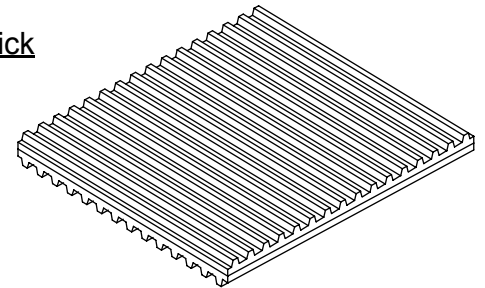

1/2" Thick

Load Capacity

Load capacity to 60 lbs./sq. inch

Thickness

Available in two thickness:

- 1/4" Ribbed on one side
- 1/2" Ribbed two sides

Non-Skid

Thread surfaces resist "walking"

Durable

Material is oil & ozone resistant Neoprene

- RP only 1/2"

| Maximum Pad Size 12" x 180" Factory Cut Sizes Listed | | | | | | | |
|--|----------------------------------|---------------|----------------------------------|---------------|----------------------------------|---------------|----------------------------------|
| Size (Inches) | Max. Load Selection at 40 P.S.I. | Size (Inches) | Max. Load Selection at 40 P.S.I. | Size (Inches) | Max. Load Selection at 40 P.S.I. | Size (Inches) | Max. Load Selection at 40 P.S.I. |
| 2x2 | 160 | 3x3 | 360 | 4 x 4 | 360 | 12 x 12 | 5760 |
| 2x3 | 240 | 3x6 | 720 | 4 x 6 | 720 | 12 x 18 | 8640 |
| 2x4 | 320 | 3x9 | 1080 | 4 x 9 | 1080 | 12 x 24 | 11520 |
| 2x6 | 480 | 3x12 | 1440 | 4 x 12 | 1440 | 12 x 36 | 17280 |
| 2 x 12 | 960 | 3 x 18 | 2160 | 4 x 18 | 2160 | 12 x 180 | 86400 * |
| 2 x 18 | 1440 | 3 x 24 | 2880 | 4 x 24 | 4320 | 18 x 18 | 12960 |
| 2 x 24 | 1920 | 3 x 36 | 4320 | 4 x 36 | 8640 | 18 x 24 | 19440 |
| 2 x 36 | 2880 | 3 x 72 | 8640 | 4 x 180 | 28800 * | | |
| 2 x 72 | 5760 | 3 x 144 | 17280 | | | | |
| 2 x 144 | 11520 | 3 x 180 | 21600 | | | | |
| 2 x 180 | 14400 | 6 x 6 | 1440 | 9 x 9 | 3240 | 24 x 24 | 23040 * |
| | | 6 x 9 | 2160 | 9 x 12 | 4320 | 24 x 36 | 35560 * |
| | | 6 x 12 | 2880 | 9 x 18 | 6480 | 36 x 36 | 51840 * |
| | | 6 x 18 | 4320 | | | | |
| | | 6 x 36 | 8640 | | | | |
| | | 6 x 180 | 43200 * | | | | |

Engineering Services

Ensuring that expected earthquake design performance objectives are met not only reduces the risk or damage to the nonstructural components itself, but also reduces the risk or damage to adjacent or closely located items from falling, overturning, swinging and impacting, leaking, etc. In addition, proper engineering reduces the life-safety risk to building occupants and, for critical facilities, provides the operability assurances necessary for Immediate Occupancy. "Critical facilities" would include hospitals, fire stations, police stations, and other such facilities.

The complex and technical nature of seismic bracing requirements, industry regulations, and life-safety issues necessitates a partner like Gripple, who can evaluate your project to determine its seismic and/or Anti-Terrorism /Force Protection (AT/FP) needs and requirements based on specific codes for the project and that particular geographic location. Gripple can offer you assurances with complete beginning-to-end seismic engineering services, such as:

PE Stamped Drawings

- Engineered seismic bracing calculations and details based upon drawings/plans provided.
- PE stamped layout drawings for each service noting the proper location of Gripple® Seismic Cable Bracing and/or Vibration Isolation products.

BIM Modeling and Clash Detection

- Provided as required by design scope. Includes 2D, 3D AutoCAD, and/or REVIT.

Coordination and Site Reviews

- With licensed Engineer and Gripple representative to ensure proper installation of seismic bracing / vibration isolation products.

Budget Estimating

- Project quotes for engineering services and products are all-inclusive and will not increase after the pre-engineering evaluation.
- We work with you to provide a base number you can work into your budget, that does not change once the project quote has been agreed upon.

Bracing & Isolation Products

- We'll provide you with the appropriate quantity of complete Gripple® Seismic Cable Brace Assembly kits and/or Vibration Isolation products, per Engineer's calculations for the required services.

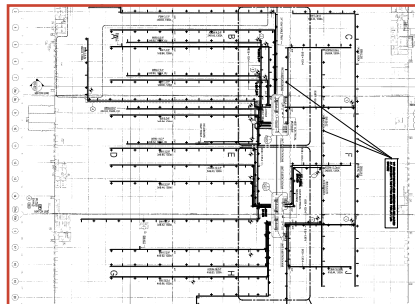
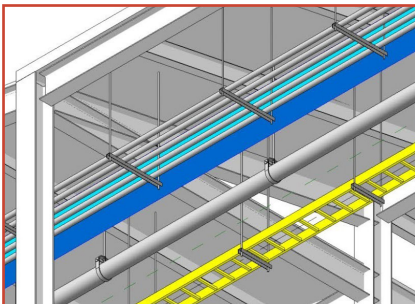

Approvals & Certifications

Gripple is proud to hold the following industry approvals for our Cable Bracing Systems:

IAPMO ER-577

Gripple Seismic bracing is recognized for compliance with following codes following an extensive testing and evaluation through Evaluation Report ER-577.

- International Building & Residential Code (IBC & IRC 2021)
- International Fire Code (IFC 2021)
- LA City Building & Residential Code (LABC & LARC 2020)(Also recognized as LARR Approved)
- National Fire Protection Association (NFPA 13)
- California State Building Code (CBC & CRC 2022)
- DSA & OSHPD

OSHPD OPA 2123-10

As a result of extensive testing and qualifications, the California Office of Statewide Health Planning & Development (OSHPD) assigned Gripple® Seismic Cable Bracing Systems GS10, GS12, and GS19 an OPA-2123-10 for Fixed Equipment Anchorage.

NEBS GR 63 Core

Gripple Inc. has successfully been tested for UL for NEBS GR 63 Core compliance.

SMACNA Verification

The Sheet Metal and Air Conditioning Contractors National Association (SMACNA) has verified that Gripple® Seismic Cable Bracing Systems are an acceptable alternative for seismic hanger bracing in strict accordance with the ANSI / SMACNA Seismic Restraint Manual – Guidelines for Mechanical Systems.

Additional Qualifications

Gripple® Seismic Cable Bracing Systems have undergone all of the proper qualifications and extensive strength testing to meet any seismic design code requirements or standards, including:

- American Society of Civil Engineers (ASCE) 7-16 Chapter 13
- Unified Facilities Criteria (UFC)
- American Society of Heating, Refrigeration, and Air Conditioning Engineers (ASHRAE)
- Federal Emergency Management Agency (FEMA)

In addition, pre-approval of Manufacturers Certification OPM-0257-13 for CalDyn JQR Vibration Isolator with Restraint has been granted by the State of California Office of Statewide Health Planning and Development after satisfying cyclic testing to destruction per FM 1950.

Complying with the California Building Code 2013 and the result of FM 1950 testing, State of California pre-approval OPM-0257-13 applies to the seismic protection of all vibration isolated equipment installed per OPM-0257-13.

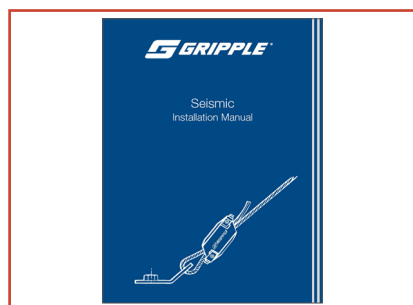

Case Studies

Mercy Hospital – Joplin, MO

| | |
|---------------------------------|--|
| Project Name | Mercy Hospital - Joplin, MO |
| Contractor | U.S. Engineering |
| Completion Date | 2013 |
| Building Type & Size | Healthcare, five floors |
| Services | Seismic Bracing for Ductwork and Piping |
| Gripple Product Used | Over 1,000 Gripple® Seismic Cable Braces |

In 2011, a tornado caused significant enough damage to St. John's Hospital in Joplin, Missouri that it was declared structurally unsafe and was consequently demolished. A week later, it was announced that a new hospital, Mercy Hospital, would be built to replace it.

Gripple® was chosen to supply both the seismic bracing and cable hanging systems for the five-story Mercy Hospital project. The Gripple® team was able to offer a unique combination of innovative products, fantastic customer service, and technical engineering services.

Gripple® challenged the traditional methods of seismic bracing and provided a more efficient, versatile, and easy-to-use system. The versatility and flexibility of the cable ensured that installation was exceptionally quick and easy.

"On this project, the Gripple® Seismic braces came pre-packaged, color coded, and numbered. You thread them through, tie them down, and cut off the excess. If we would have used traditional methods, we would have had half a trailer full of parts and pieces. With Gripple® Seismic braces, we just have a couple pallets, with everything color coded and bagged on each installation."

- Dan Hausback, Senior Project Manager

"Most of the seismic bracing that we do is not easily accessible, so the guys have to drag spools with them, crimping tools, and everything else. Gripple® Seismic is just very handy."

- Tony Freeman, Foreman

To complement the innovative products, Gripple® also provided fantastic customer service throughout all stages of the project. In addition, Gripple's dedicated Estimating team were able to provide efficient and accurate turnarounds on drawings, while ensuring consistent assistance with any queries about the installations.



Martin Army Community Hospital – Fort Benning, GA

| | |
|---------------------------------|---|
| Project Name | Martin Army Community Hospital - Fort Benning, GA |
| Contractor | M.C. Dean |
| Building Type & Size | 750,000 sq.ft. healthcare facility consisting of (1) Hospital, (2) Clinics, and (2) Parking Garages |
| Application | Seismic restraints, and primary supports for conduit trapeze racks |
| Gripple Product Used | 6,300 Seismic Cable Braces, and 320,000 Cable Hangers |
| Products | GS12, GS19, Toggle Cable Hangers, and 90° Eyelet Cable Hangers |
| Savings - Man Hours | 106,000 |
| Savings - Dollars | \$9.54 Million |

On this project, the flexibility of the products impressed Project Superintendent, David Timberlake, who stated, “The biggest benefit is the flexibility of Gripple. During installation with Gripple, you are able to install around things you normally wouldn’t. That is the biggest benefit we see.”

Naturally, the flexibility of the products reduces installation times and, consequently, labor rates. David recommends considering Gripple® Seismic cable braces because, “It allows a quicker install and it’s just more versatile than anything else.”

Backing this up, M.C. Dean Foreman, Jared Strande, says, “The best thing about the Gripple® system is that it is really versatile in real world situations. It’s much quicker and much more efficient than traditional methods.”

To complement the Gripple Seismic products, accurate engineered drawings were also issued for the project, ensuring a full turnkey solution was provided. This proved to be another enticing service for Willy Lizarraga, Operations Manager, who said, “The aspect that I liked about Gripple’s seismic solutions was the time associated with getting the drawings, providing the drawings to the owner for approval, and therefore, providing a turnkey solution. That was very attractive.”

In summary, Willy Lizarraga states, “The benefits of using the Gripple system are that it’s a turnkey solution, the materials arrive efficiently at the jobsite, and the installation, labor-wise, is a lot easier than using other competitors.”

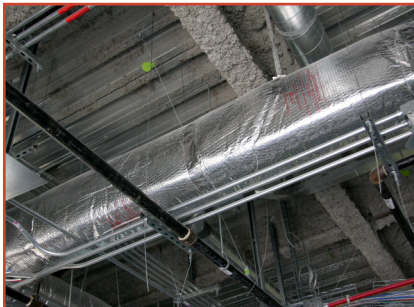

Gripple Seismic Projects

Gripple® Seismic products have been specified on many prestigious construction projects across North America, for both new and retrofit installations, in order to enhance the stability of nonstructural equipment and components during a seismic event. Types of equipment and services that have been braced with Gripple® Seismic include: VAV boxes, sprinkler pipe, electrical cable tray, junction boxes, lighting, ductwork, plumbing, fan coil units, and more.

Below is a sampling of projects where Gripple® Seismic Cable Bracing systems have been installed. For more information or details regarding completed projects, please contact the Gripple Territory Manager in your region.

Research/Labs

- Abbott Laboratories
- Integra, Life Sciences Biopatch Facility
- Janssen Ortho Tapentadol
- Montsantos
- Pioneer/DuPont Bioagriculture R&D Lab
- Sartorius Stedim Biotech
- UCSF Neurological Building

Healthcare

- Alton Memorial Hospital
- AtlantiCare Regional Med. Ctr.
- Belleville Hospital
- Evergreen Cancer Center
- Hoag Hospital
- Kadlec Medical Building
- Kaiser Permanente - South Baltimore Medical Center
- Kennewick General Hospital
- Medical College of Virginia - Labor & Delivery
- Mercy Hospital
- Milgard Medical
- Mission Bay Hospital
- Procure Medical
- Rainier Tower
- San Jorge Childrens Hospital
- St. Anthony's Hospital
- US Veterans Hospital
- VA Outpatient Clinic
- Virginia Breast Center - Bon Secours Medical Group
- Wishard Hospital

Manufacturing

- Abbott Vascular
- Anchorage Sport Fish Hatchery
- Boeing 737 Plant
- Caterpillar Plant
- Dupont Febreze Facility
- Elliott Bay Brewery
- EngerG2
- Global Foundries
- Intel
- Kruger Paper
- Monroe Waste Water Treatment Plant
- Tillamook County Creamery
- Warner Chilcott

Government/Military

- Elmendorf Air Force Base
- Fort Benning
- Fort Buchanan
- Fort Hunter Liggett
- Kanata Fire Station
- National Archives and Records Administration (NARA)
- Naval Surface Warfare Center
- Ontario Provincial Police
- Puerto Rico National Guard Armed Forces Reserve
- Scott Air Force Base
- TVF & R Fire Station
- Veterans Affairs Parking Garage

Entertainment

- Golden Nugget Hotel/Casino
- Seminole Indian Tribe Hard Rock Casino Parking Garage

Educational

- Algonquin College
- Baker Middle School
- Eastmont High School
- Joseph Gale Elementary
- Sharbot Lake School
- Sterling Middle School
- Trillium Creek School
- Woodburn Elementary

Office & Retail

- Air Canada Operations Centre
- Amazon.com
- Chevron Oil Company
- Edward Jones South Building
- Forever 21 Store, Plaza Del Caribe
- Glumac TI
- IKEA Montreal
- Siemens
- Tivoli Village

Data Storage

- Microsoft Columbia Data Center
- Pillar 2 (Prineville, OR)
- Riker Data Center
- Additional Projects
- Grace Bible Church
- Manhattan Community Garage
- Metropista de Puerto Rico
- Mother C. Hale Bus Depot
- Perris Station Sr. Apartments
- St. Andrews Lutheran Church



IKEA, Montreal

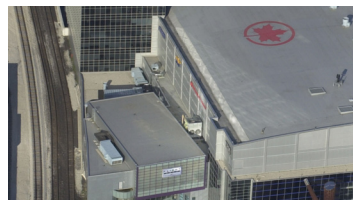

Air Canada Operations Centre,
Brampton



Amazon facility, Seattle

Our Company

Gripple is the global leader of cable suspension solutions for the construction market, as well as of wire joiners and tensioners for the agriculture and viticulture market.

Celebrating our 25th anniversary in 2014, we are known throughout the world for innovation, quality and best practice. With sales in over 90 countries and manufacturing facilities in North America, the UK, Europe, and India, Gripple maintains ambitious growth plans which will see the company seeking to further engage the world with its unique, patented technology.

The key to our success is finding effective solutions. We make a difficult, timely and cumbersome job fast and easy. We always focus on the user's needs, and by engraining this principle of solving problems into every person throughout the company, Gripple now not only provides a vast range of high quality, problem solving products, but customer service, technical, and sales support that exceeds customer expectations.

We currently operate in five main industries, but are continually exploring new markets, applications and opportunities.

Civil Construction

Slope stabilization, erosion control and landscaping

Building Services

Suspension systems for mechanical, electrical, piping, HVAC services, lighting, acoustic and signage installations

Viticulture, Orchards and Fencing

Cable joiners, tensioners and bracing for vineyard and orchard trellising and fencing

Landscape & Nursery

Anchoring and trellising solutions for landscaping and nurseries

Seismic and Anti-Terrorism/Force Protection

Bracing systems for suspended non-structural building components

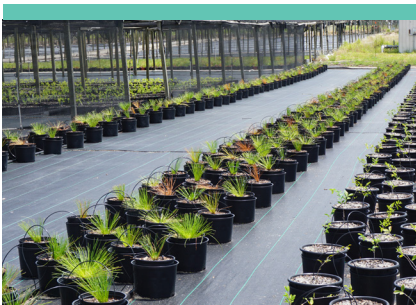

Seismic Hazard Map

CANADA SEISMIC MAP

What we do:

Gripple provides complete turn-key seismic and force protection solutions for your project's non-structural components requiring seismic design and Anti-Terrorism / Force Protection (AT/FP).

Non-structural building components are critical for the proper functioning of a building, and make up a high percentage of a building's damage in a seismic event. Properly engineered bracing of these services is required by code depending on the occupancy and the site location. If the building is considered an essential facility, these services are required to stay in place and remain operational in the aftermath of a seismic or blast event.

From the design to the construction phase, Gripple can provide code interpretation, implementation of seismic requirements in bid documents, vibration isolation and seismic restraint, full scope quotes, project management, on-site installation training, sign-off letters and more.

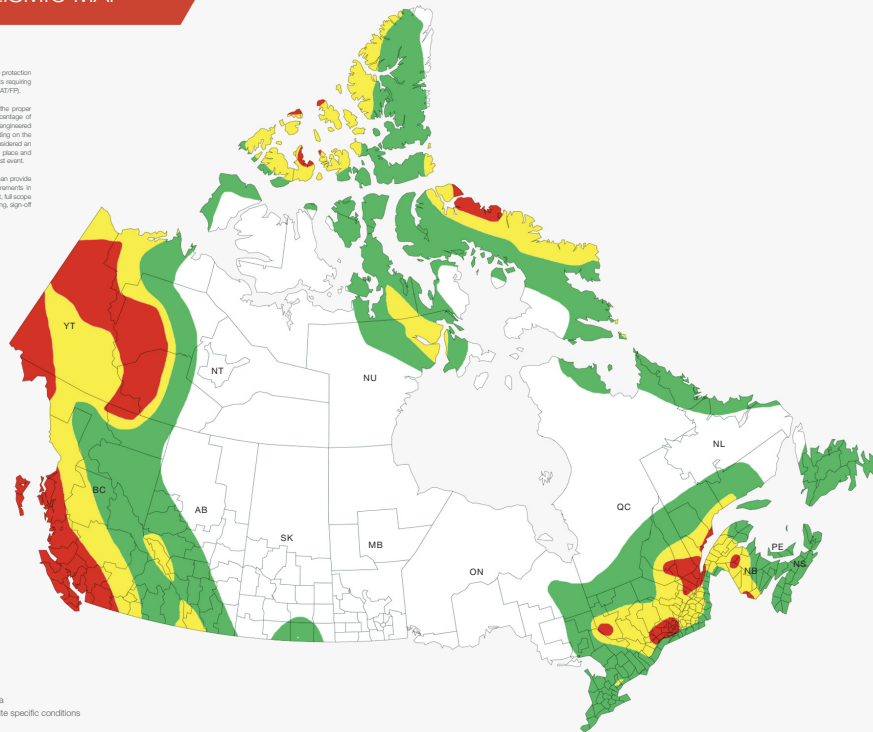

Highest Hazard



Lowest Hazard

Disclaimers:

- Map to be used for reference only
- Reference: Natural Resources Canada
- Consult with Structural Engineer for site specific conditions



www.gripple.com

Gripple Inc | 1611 Emily Lane | Aurora, IL 60502 | USA
Tel +1 866 474 7753 Fax +1 800 654 0689 Email gripplec@gripple.com



U.S. SEISMIC MAP

What we do:

Gripple provides complete turn-key seismic and force protection solutions for your project's non-structural components requiring seismic design and Anti-Terrorism / Force Protection (AT/FP).

Non-structural building components are critical for the proper functioning of a building, and make up a high percentage of a building's damage in a seismic event. Properly engineered bracing of these services is required by code depending on the occupancy and the site location. If the building is considered an essential facility, these services are required to stay in place and remain operational in the aftermath of a seismic or blast event.

From the design to the construction phase, Gripple can provide code interpretation, implementation of seismic requirements in bid documents, vibration isolation and seismic restraint, full scope quotes, project management, on-site installation training, sign-off letters and more.

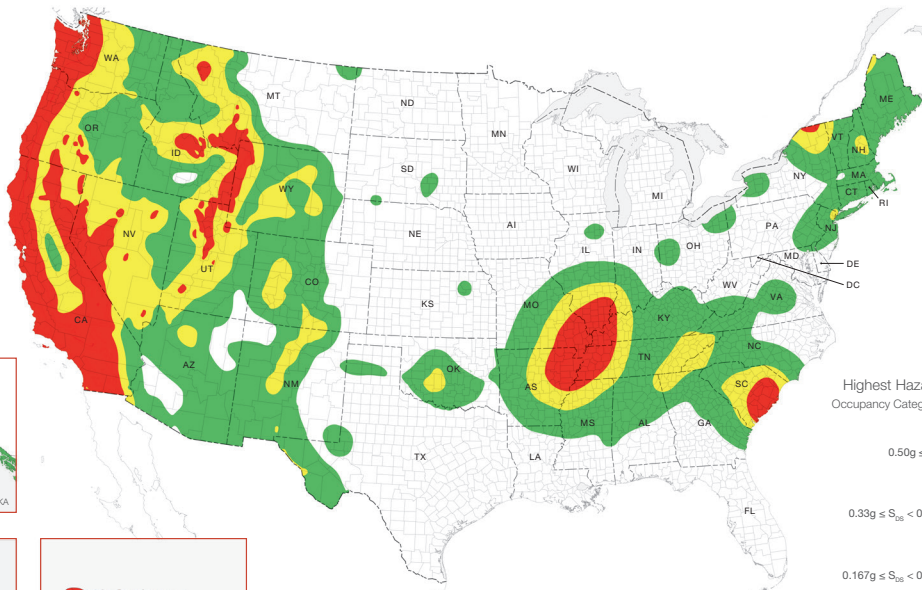

Highest Hazard (% g)
Occupancy Category (I, II, III)



Lowest Hazard

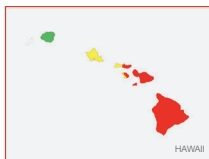
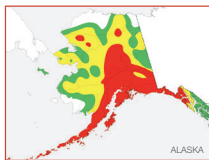

| Value of S_{DS} | Occupancy Category | |
|------------------------------|--------------------|----|
| | I, II, III | IV |
| $0.50g \leq S_{DS}$ | D | D |
| $0.33g \leq S_{DS} < 0.50g$ | C | D |
| $0.167g \leq S_{DS} < 0.33g$ | B | C |
| $S_{DS} < 0.167g$ | A | A |

Disclaimers:

- Map to be used for reference only
- Reference: USGS simplified 2014 Hazard Map (PGA, 2% in 50 years)
- Consult with Structural Engineer for site specific conditions
- Map assumes site class D
- State code values may be higher than shown
- Seismic Design Category for the design / engineering purpose shall be decided based on both S_{DS} & S_{D1} , which ever is most stringent.



www.gripple.com

Gripple Inc | 1611 Emily Lane | Aurora, IL 60502 | USA
Tel +1 866 474 7753 Fax +1 800 654 0689 Email gripplec@gripple.com



Notes, Drawings & Calculations

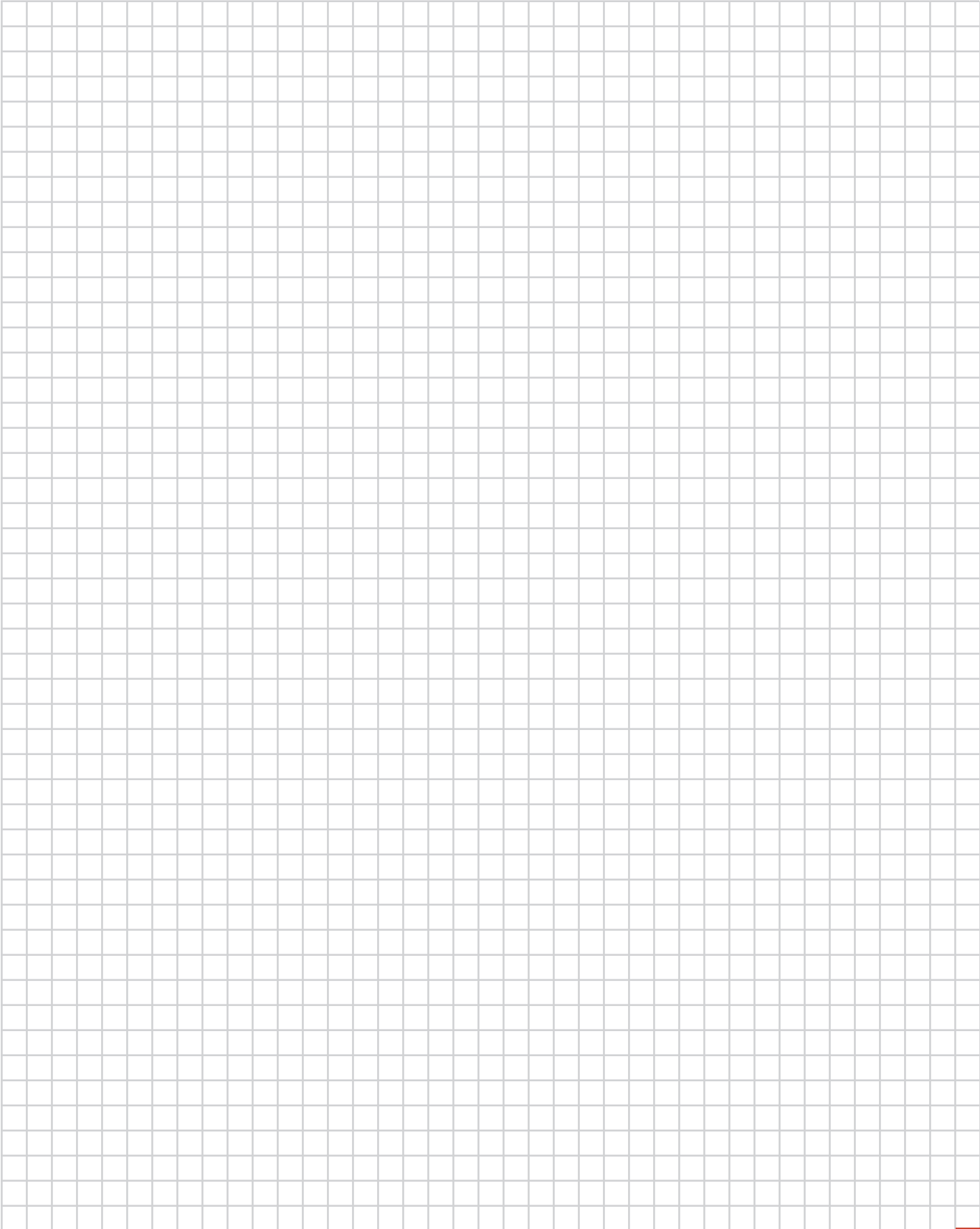

www.gripple.com
grippleinc@gripple.com

Gripple Inc

1611 Emily Lane
Aurora, IL 60502
USA

T | +1 866 474 7753
F | +1 800 654 0689
E | grippleinc@gripple.com

Gripple Ltd (Headquarters)

The Old West Gun Works
Savile Street East
Sheffield S4 7UQ
UK

T | +44 (0) 800 018 4264
F | +44 (0) 114 275 1155
E | info@gripple.com

Gripple Europe SARL

1, rue du Commerce
BP 37
67211 Obernai Cedex
France

T | +33 (0)3 88 95 44 95
F | +33 (0)3 88 95 08 78
E | frinfo@gripple.com

Gripple India

C-115, Industrial Area
Phase I, Naraina
New Delhi-110028
India

T | +91 11-40582703
F | +91 11-40582703
E | ininfo@gripple.com

Gripple Canada Inc

6665 Tomken Road
Unit 9-10 Mississauga
Ontario L5T 2C4
Canada

T | +1 905 458 8700
F | +1 800 654 0689
E | cainfo@gripple.com

Gripple Japan K.K

2-57 Tsukizi-cho
Hyogo-ku, Kobe-shi
Hyogo, 652-0845
Japan

T | +81 (0) 78 681 2121
F | +81 (0) 78 681 2122
E | japan@gripple.com

BROC-SFP-US

Digital AUG 2022

Please refer to www.gripple.com for
the most up to date user advice and
product information.



A GLIDE company



© 2022 Gripple.

Gripple is a registered trademark of Gripple Limited.
Company registered in England No. 1772901, VAT Reg No. GB 600 1951 88